

FCC RADIO TEST REPORT

For

FCC ID: 2A0BMWBCW140

Report Reference No..... : 18EEAS09052 21
Date of issue..... : 2018-9-13
Testing Laboratory..... : DongGuan ShuoXin Electronic Technology Co., Ltd.
Address..... : Zone A, 1F, No. 6, XinGang Road YuanGang Street, XinAn
District, ChangAn Town, DongGuan City, GuangDong,
China
Applicant's name : International Products Sourcing Group
Address..... : 4119 Leap Road, Hilliard OH, 43026
Manufacturer..... : Shenzhen Emdoor Digital Technology Co.,Ltd
Test specification:
Test item description..... : 14" Notebook PC
Trade Mark : WINBOOK
Model/Type reference : CW140
Ratings..... : INPUT: 100-240V~ 50/60HZ 1.5A, OUTPUT: DC19V 2.37A
DC 7.6V 5920mAh Li-polymer Battery

Responsible Engineer :

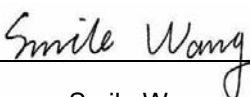
Smile Wang

Authorized Signatory:

King Wang

TABLE OF CONTENTS

1.	Summary of test results	4
2.	General test information.....	5
2.1.	Description of EUT.....	5
2.2.	Accessories of EUT	6
2.3.	Assistant equipment used for test	6
2.4.	Block diagram of EUT configuration for test	7
2.5.	Test environment conditions	7
2.6.	Test environment conditions	8
2.7.	Measurement uncertainty	8
3.	POWER SPECTRAL DENSITY TEST	9
3.1.	Test equipment.....	9
3.2.	Block diagram of test setup	9
3.3.	Applied procedures / limit.....	9
3.4.	Test Procedure	10
3.5.	Test Result	11
4.	26 dB & 99% Emission Bandwidth	30
4.1.	Test equipment.....	30
4.2.	Block diagram of test setup	30
4.3.	Applied procedures / limit.....	30
4.4.	Test Procedure	30
4.5.	Test Result	31
5.	MAXIMUM CONDUCTED OUTPUT POWER.....	66
5.1.	Test Result	67
6.	Band Edges Measurement	69
6.1.	Test Result	71
7.	RADIATED EMISSION MEASUREMENT	77
7.1.	Test equipment.....	77
7.2.	Block diagram of test setup	78
7.3.	Limit.....	80
7.4.	Test Procedure	81
7.5.	Test result(Below 30MHz)	83
8.	FREQUENCY STABILITY	91
9.	Power Line Conducted Emission.....	95
9.1	Test equipment.....	95
9.2	Block diagram of test setup	95
9.3	Power Line Conducted Emission Limits(Class B).....	95

9.5 Test Result	96
10. Antenna Requirements.....	99
10.1. Limit.....	99
10.2. EUT ANTENNA.....	99

TEST REPORT DECLARE

Applicant	:	International Products Sourcing Group
Address	:	4119 Leap Road, Hilliard OH, 43026
Equipment under Test	:	14" Notebook PC
Model No	:	CW140
Trade Mark	:	WINBOOK
Manufacturer	:	Shenzhen Emdoor Digital Technology Co.,Ltd
Address	:	H.Q.:6/F JinFuLai Building,49-1 Dabao Road, Bao An District, Shenzhen

Test Standard Used: FCC Part 15E 15.407

Test procedure used: ANSI C63.10-2013 and KDB 789033 D02 General UNII Test Procedures New Rules v02r01 .

We Declare:

The equipment described above is tested by DongGuan ShuoXin Electronic Technology Co., Ltd. and in the configuration tested the equipment complied with the standards specified above. The test results are contained in this test report and DongGuan ShuoXin Electronic Technology Co., Ltd. is assumed of full responsibility for the accuracy and completeness of these tests.

After test and evaluation, our opinion is that the equipment provided for test compliance with the requirement of the above FCC standards.

Report No:	18EEAS09052 21		
Date of Test:	2018-09-13--2018-9-20	Date of Report:	2018-09-21

Note: This report applies to above tested sample only. This report shall not be reproduced in parts without written approval of DongGuan ShuoXin Electronic Technology Co., Ltd.

1. SUMMARY OF TEST RESULTS

The EUT have been tested according to the applicable standards as referenced below.		
FCC Part15 (15.407) , Subpart E		
Description of Test Item	Standard	Results
AC Power Line Conducted Emissions	FCC §15.207/ RSS-Gen	PASS
Spurious Radiated Emissions	FCC §15.209(a), 15.407(b)	PASS
26 dB and 99% Emission Bandwidth	FCC §15.407(a)	PASS
Maximum Conducted Output Power	FCC §407(a)(1)	PASS
Band Edges	FCC §2.1051, §15.407(b)	PASS
Power Spectral Density	FCC §15.407(a)(1)	PASS
Spurious Emissions at Antenna Terminals	FCC §2.1051, §15.407(b)	PASS
Frequency Stability	FCC §15.407(a)(6)	PASS
Antenna Requirement	FCC §15.203	PASS

2. GENERAL TEST INFORMATION

2.1. DESCRIPTION OF EUT

EUT* Name	:	14" Notebook PC
Model Number	:	CW140
EUT function description	:	14" Notebook PC with WiFi & BT function.
Power supply	:	INPUT: 100-240V~ 50/60HZ 1.5A, OUTPUT: DC19V 2.37A DC 7.6V 5920mAh Li-polymer Battery
Adaptor	:	ADP060-190237
Operation frequency	:	WiFi: 802.11a/802.11n(HT20) /ac(VHT20): 5180MHz ~ 5240MHz; 5745MHz ~ 5825MHz 802.11n(HT40)/ac(VHT40): 5190MHz ~ 5230MHz, 5755MHz ~ 5795MHz 802.11ac(VHT80): 5210MHz, 5775MHz,
Modulation	:	OFDM with OFDM, BPSK, QPSK, 16QAM, 64QAM, 256QAM for 802.11a/n/ac;
Data Rate	:	802.11 a: 6,9,12,18,24,36,48,54Mbps; 802.11n(HT20):MCS0-MCS7; 802.11n(HT40): MCS0-MCS7; 802.11ac(HT20/HT40/HT80):Up to 433Mbps
Antenna Type	:	FPCB antenna, maximum PK gain: 1dBi Antenna A only WIFI, Antenna B WIFI&BT
Battery	:	N/A
Date of Receipt	:	2018/09/13
Sample Type	:	N/A

UNII-1		UNII-1		UNII-1	
Channel	Frequency (MHz)	Channel	Frequency (MHz)	Channel	Frequency (MHz)
36	5180	38	5190	42	5210
40	5200	46	5230		
44	5220				
48	5240				

UNII-4		UNII-4		UNII-4	
Channel	Frequency (MHz)	Channel	Frequency (MHz)	Channel	Frequency (MHz)
149	5745	151	5755	155	5775
153	5765	159	5795		
157	5785				
161	5805				
165	5825				

2.2.ACCESSORIES OF EUT

Description of Accessories	Shielded Type	Ferrite Core	Length
Adapter	/	/	/

2.3.ASSISTANT EQUIPMENT USED FOR TEST

Description of Assistant equipment	Manufacturer	Model number or Type	EMC Compliance	SN
/	/	/	/	/

2.4. BLOCK DIAGRAM OF EUT CONFIGURATION FOR TEST



2.5. TEST ENVIRONMENT CONDITIONS

To investigate the maximum EMI emission characteristics generates from EUT, the test system was pre-scanning tested base on the consideration of following EUT operation mode or test configuration mode which possible have effect on EMI emission level. Each of these EUT operation mode(s) or test configuration mode(s) mentioned above was evaluated respectively.

Pretest Mode	Description
Mode 1	Link Mode
Mode 2	802.11a / n 20/ac20 CH36/ CH40/ CH48 802.11a / n 20/ac20 CH149/ CH157/ CH165
Mode 3	802.11n40/ac40 CH38/ CH 46 802.11 n40/ac40 CH151/ CH159

For Radiated Emission	
Final Test Mode	Description
Mode 1	Link Mode
Mode 2	802.11a / n 20 CH36/ CH40/ CH48 802.11a / n 20 CH149/ CH157/ CH165
Mode 3	802.11n40 CH38/ CH 46 802.11 n40 CH151/ CH159

Note:

- (1) The measurements are performed at the highest, middle, lowest available channels.
- (2) The measurements are performed at all Bit Rate of Transmitter, the worst data was reported
- (3) The EUT was used fully-charged battery and programmed to be in continuously transmitting mode and the transmit duty cycle is not less than 98%.
- (4) The EUT does not support MIMO mode.

2.6. TEST ENVIRONMENT CONDITIONS

During the measurement the environmental conditions were within the listed ranges:

Temperature range:	21-25°C
Humidity range:	40-75%
Pressure range:	86-106kPa

2.7. MEASUREMENT UNCERTAINTY

Test Item	Uncertainty
Uncertainty for Conduction emission test (9kHz-150kHz)	3.7 dB
Uncertainty for Conduction emission test (150kHz-30MHz)	3.3 dB
Uncertainty for Radiation Emission test (30MHz-200MHz)	4.6 dB (Polarize: V)
	4.6 dB (Polarize: H)
Uncertainty for Radiation Emission test (200MHz-1GHz)	6.0 dB (Polarize: V)
	5.0 dB (Polarize: H)
Uncertainty for Radiation Emission test (1GHz-6GHz)	5.1 dB (Polarize: V)
	5.1 dB (Polarize: H)
Uncertainty for Radiation Emission test (6GHz-18GHz)	5.4 dB (Polarize: V)
	5.4 dB (Polarize: H)
Uncertainty for Radiation Emission test (18GHz-40GHz)	5.06 dB (Polarize: V)
	5.06 dB (Polarize: H)
Uncertainty for radio frequency	±0.048kHz
Uncertainty for conducted RF Power	±0.32dB

Note: This uncertainty represents an expanded uncertainty expressed at approximately the 95% confidence level using a coverage factor of k=2.

3. POWER SPECTRAL DENSITY TEST

3.1. TEST EQUIPMENT

Item	Equipment	Manufacturer	Model No.	Serial No.	Cal Due.	Cal. Interval
1	Spectrum analyzer	KEYSIGHT	N9010A	MY55150427	2019/05/25	1 Year
2	Attenuator	Mini-Circuits	BW-S10W2	101109	2018/12/17	1 Year
3	RF Cable	Micable	C10-01-01-1	100309	2018/12/17	1 Year
4	Spectrum analyzer	R&S	FSV40	101470	2019/06/28	1 Year

3.2. BLOCK DIAGRAM OF TEST SETUP

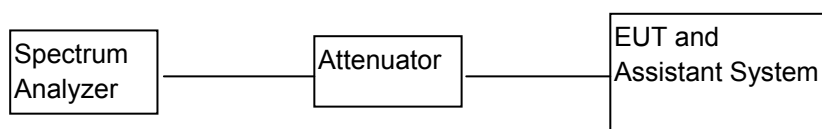

3.3. APPLIED PROCEDURES / LIMIT

According to FCC §15.407(a)(3)

For the band 5.15-5.25 GHz,

(i) For an outdoor access point operating in the band 5.15-5.25 GHz, the maximum power spectral density shall not exceed 17 dBm in any 1 megahertz band. If transmitting antennas of directional gain greater than 6 dBi are used, both the maximum conducted output power and the maximum power spectral density shall be reduced by the amount in dB that the directional gain of the antenna exceeds 6 dBi. The maximum e.i.r.p. at any elevation angle above 30 degrees as measured from the horizon must not exceed 125 mW (21 dBm).

(ii) For an indoor access point operating in the band 5.15-5.25 GHz, the maximum power spectral density shall not exceed 17 dBm in any 1 megahertz band. If transmitting antennas of directional gain greater than 6 dBi are used, both the maximum conducted output power and the maximum power spectral density shall be reduced by the amount in dB that the directional gain of the antenna exceeds 6 dBi.

(iii) For fixed point-to-point access points operating in the band 5.15-5.25 GHz, the maximum power spectral density shall not exceed 17 dBm in any 1 megahertz band. Fixed point-to-point U-NII devices may employ antennas with directional gain up to 23 dBi without any corresponding reduction in the maximum conducted output power or maximum power spectral density. For fixed point-to-point transmitters that employ a directional antenna gain greater than 23 dBi, a 1 dB reduction in maximum conducted output power and maximum power spectral density is required for each 1 dB of antenna gain in excess of 23 dBi. Fixed, point-to-point operations exclude the use of point-to-multipoint systems, omnidirectional applications, and multiple collocated transmitters transmitting the same information. The operator of the U-NII device, or if the equipment is professionally installed, the installer, is responsible for ensuring that systems employing high gain directional antennas are used exclusively for fixed, point-to-point operations.

(iv) For mobile and portable client devices in the 5.15-5.25 GHz band, the maximum power spectral density shall not exceed 11 dBm in any 1 megahertz band. If transmitting antennas of directional gain greater than 6 dBi are used, both the maximum conducted output power and the maximum power spectral density shall be reduced by the amount in dB that the directional gain of the antenna exceeds 6 dBi.

For the band 5.725-5.85 GHz
For the band 5.725-5.85 GHz, the maximum power spectral density shall not exceed 30 dBm in any 500-kHz band. If transmitting antennas of directional gain greater than 6 dBi are used, both the maximum conducted output power and the maximum power spectral density shall be reduced by the amount in dB that the directional gain of the antenna exceeds 6 dBi..

3.4. TEST PROCEDURE

(For devices operating in the bands 5.15-5.25 GHz, 5.25-5.35 GHz, and 5.47-5.725 GHz, the above procedures make use of 1 MHz RBW to satisfy directly the 1 MHz reference bandwidth specified in § 15.407(a)(5). For devices operating in the band 5.725-5.85 GHz, the rules specify a measurement bandwidth of 500 kHz. Many spectrum analyzers do not have 500 kHz RBW, thus a narrower RBW may need to be used. The rules permit the use of a RBWs less than 1 MHz, or 500 kHz, “provided that the measured power is integrated over the full reference bandwidth” to show the total power over the specified measurement bandwidth (i.e., 1 MHz, or 500 kHz). If measurements are performed using a reduced resolution bandwidth (< 1 MHz, or < 500 kHz) and integrated over 1 MHz, or 500 KHz bandwidth, the following adjustments to the procedures apply:

- a) Set $RBW \geq 1/T$, where T is defined in section II.B.I.a).
- b) Set $VBW \geq 3 RBW$.
- c) If measurement bandwidth of Maximum PSD is specified in 500 kHz, add $10\log(500\text{kHz}/RBW)$ to the measured result, whereas RBW (< 500 KHz) is the reduced resolution bandwidth of the spectrum analyzer set during measurement.
- d) If measurement bandwidth of Maximum PSD is specified in 1 MHz, add $10\log(1\text{MHz}/RBW)$ to the measured result, whereas RBW (< 1 MHz) is the reduced resolution bandwidth of spectrum analyzer set during measurement.
- e) Care must be taken to ensure that the measurements are performed during a period of continuous transmission or are corrected upward for duty cycle.

Note: As a practical matter, it is recommended to use reduced RBW of 100 KHz for the sections 5.c) and 5.d) above, since RBW=100 KHz is available on nearly all spectrum analyzers.

3.5. TEST RESULT

CH. No.	Frequency	Power Density ANT A (dBm/MHz)	Power Density ANT B (dBm/MHz)	total power density (dBm/MHz)	Limit (dBm/MHz)	Result
TX 802.11a Mode						
CH36	5180	4.39	4.02	--	11	Pass
CH40	5200	4.35	4.01	--	11	Pass
CH48	5240	4.63	4.16	--	11	Pass
CH 149	5745	-0.81	-1.68	--	30	Pass
CH 157	5785	0.25	-0.13	--	30	Pass
CH 165	5825	0.62	-0.21	--	30	Pass
TX 802.11n20 Mode						
CH36	5180	4.19	4.03	--	11	Pass
CH40	5200	3.86	3.14	--	11	Pass
CH48	5240	4.93	3.65	--	11	Pass
CH 149	5745	-1.12	-2.03	--	30	Pass
CH 157	5785	-0.36	-1.32	--	30	Pass
CH 165	5825	-0.14	-0.84	--	30	Pass
TX 802.11n40 Mode						
CH38	5190	1.84	0.68	--	11	Pass
CH46	5230	2.85	1.33	--	11	Pass
CH151	5755	-3.56	-4.71	--	30	Pass
CH159	5795	-3.52	-4.03	--	30	Pass

CH. No.	Frequency	Power Density ANT A (dBm/MHz)	Power Density ANT B (dBm/MHz)	total power density (dBm/MHz)	Limit (dBm/MHz)	Result
TX 802.11 ac(VHT20) Mode						
CH36	5180	4.00	3.71	--	11	Pass
CH40	5200	3.87	3.39	--	11	Pass
CH48	5240	4.98	4.06	--	11	Pass
CH 149	5745	-0.61	-1.26	--	30	Pass
CH 157	5785	-0.43	-1.04	--	30	Pass
CH 165	5825	-0.33	-0.98	--	30	Pass
TX 802.11 ac(VHT40) Mode						
CH38	5190	1.88	1.36	--	11	Pass
CH46	5230	2.25	1.74	--	11	Pass
CH 151	5755	-3.38	-4.63	--	30	Pass
CH 159	5795	-4.18	-4.74	--	30	Pass
TX 802.11 ac(VHT80) Mode						
CH42	5210	-2.67	-3.01	--	11	Pass
CH155	5775	-6.61	-7.12	--	30	Pass

Note: The worst data is Antenna A, only shown Antenna A Plot.

Test plots as followed: Antenna A

802.11a
Channel: 36

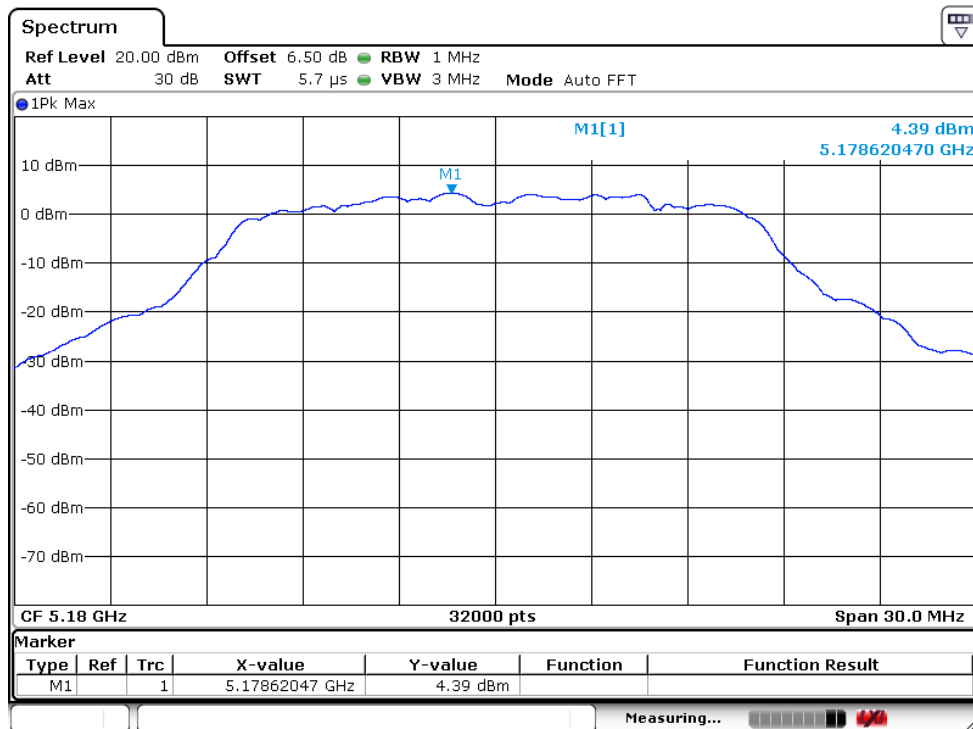

Channel: 40

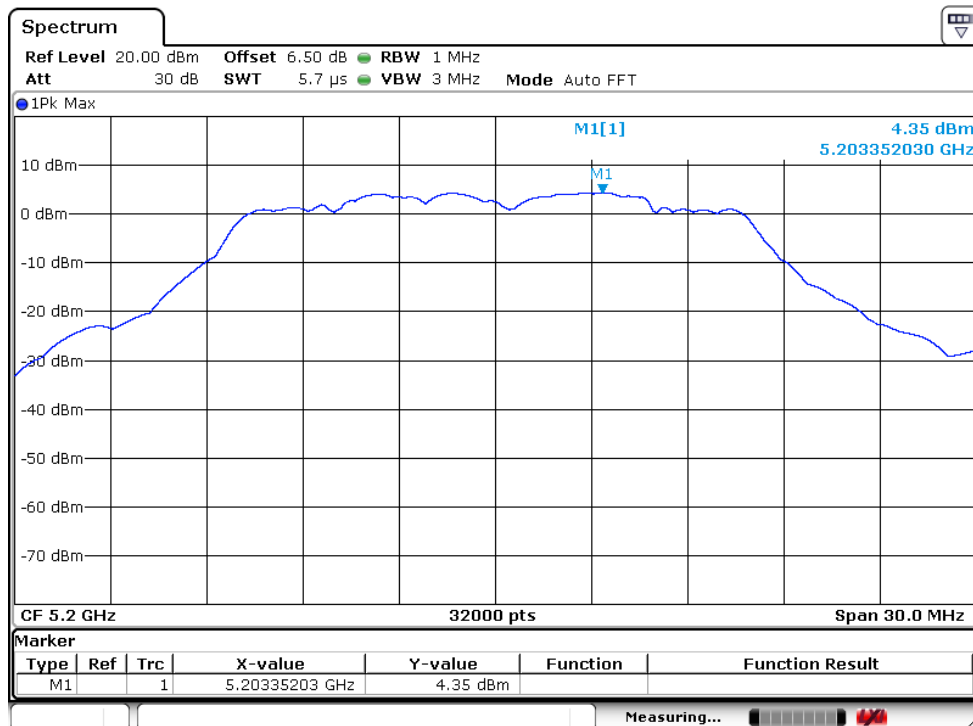

Channel: 48

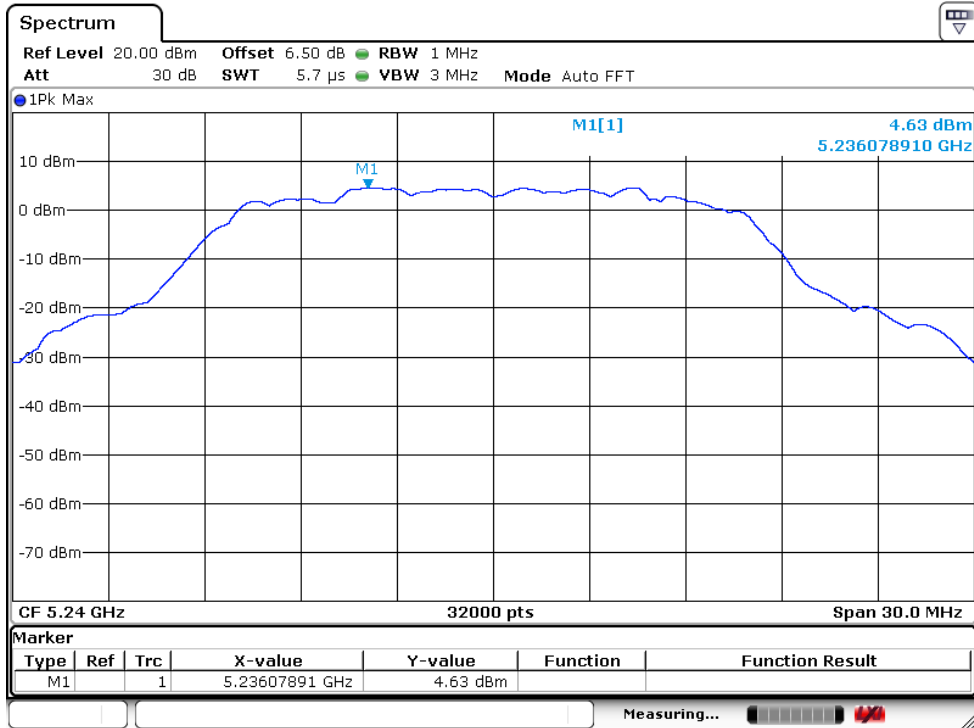

802.11n20 Channel: 36

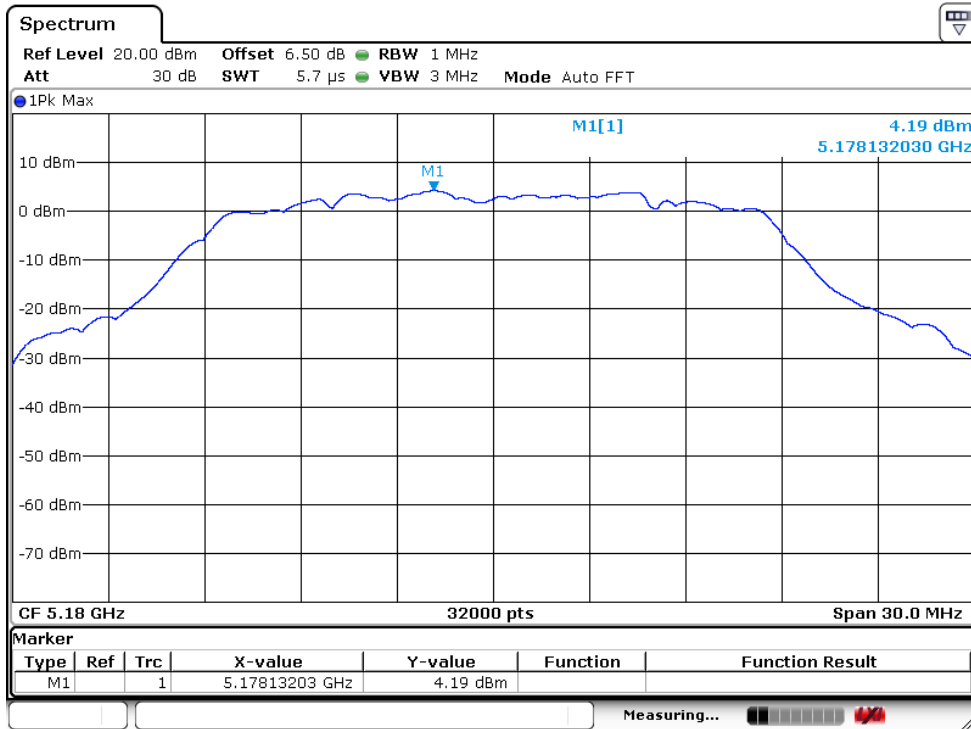

Channel: 40

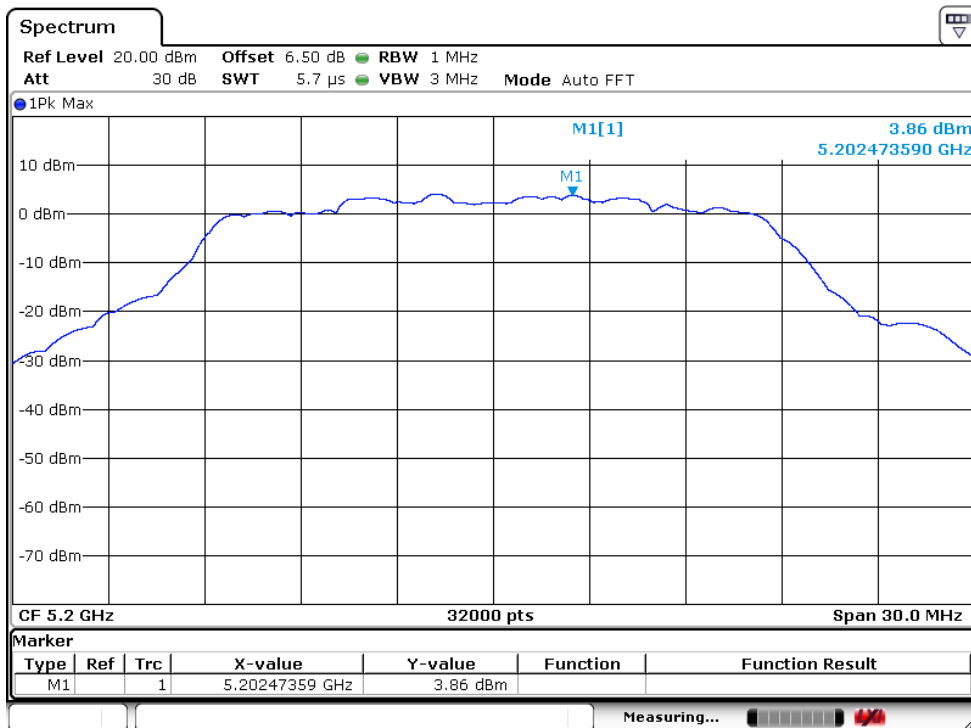

Channel: 48

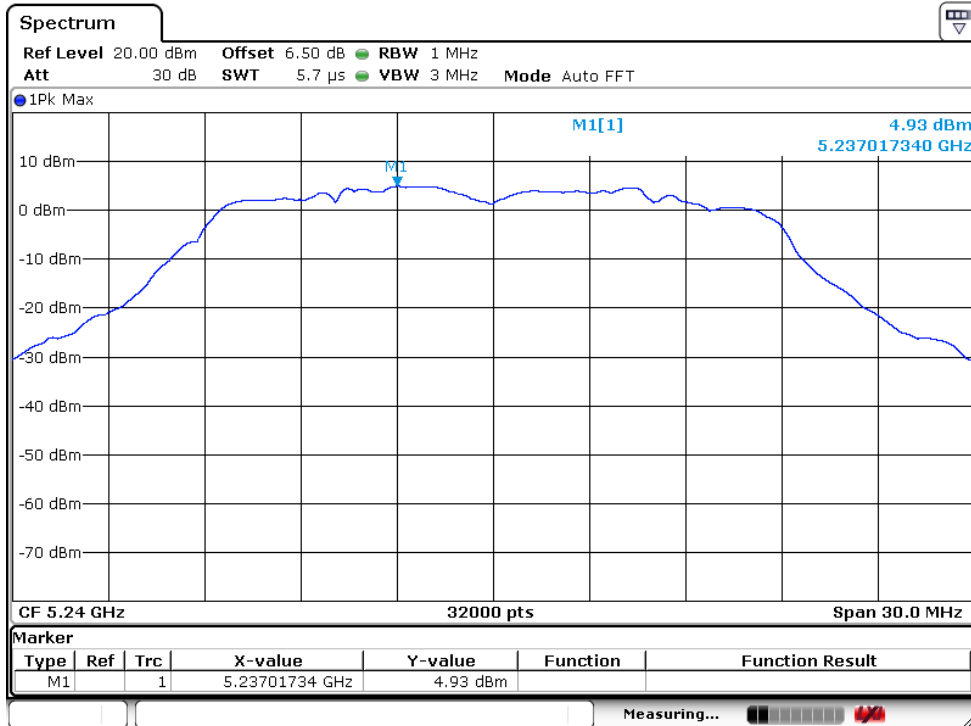

802.11ac20 Channel: 36

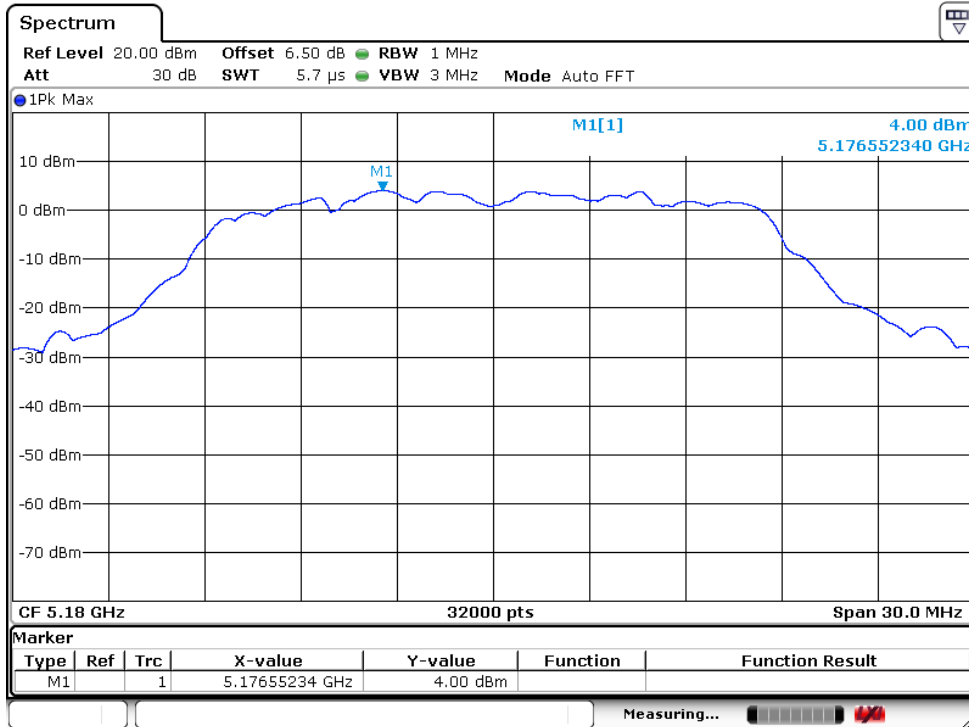

Channel: 40

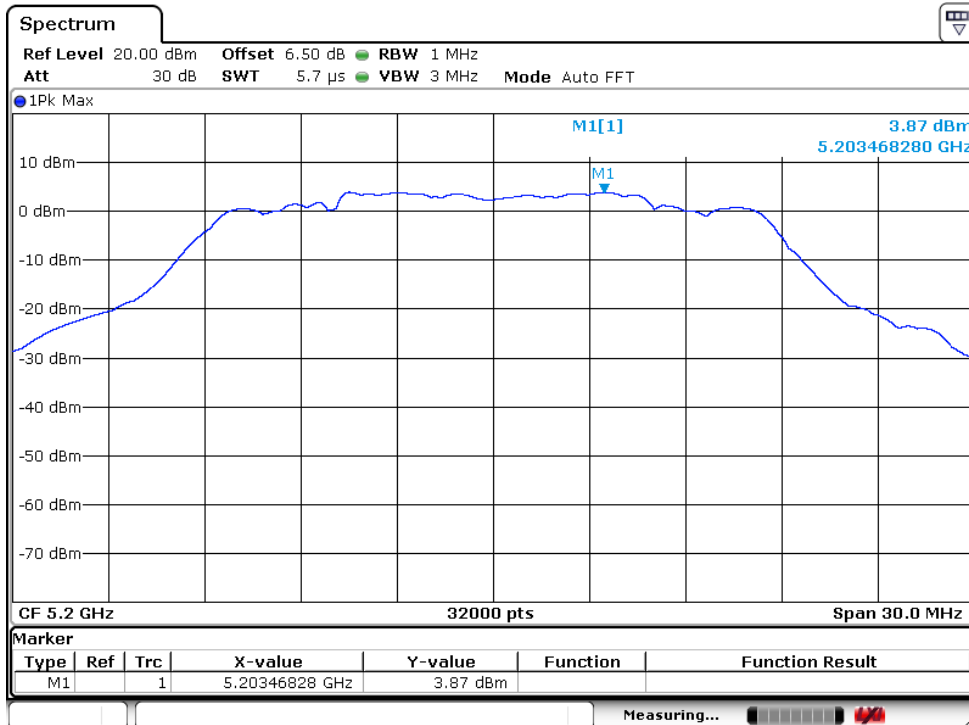

Channel: 48

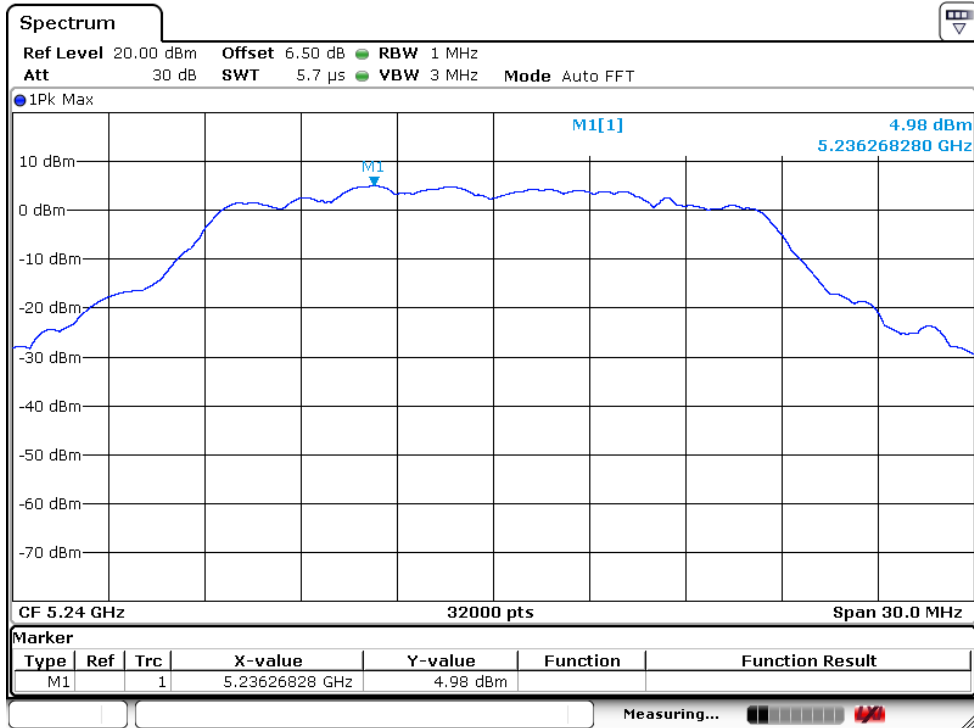

802.11a Channel: 149

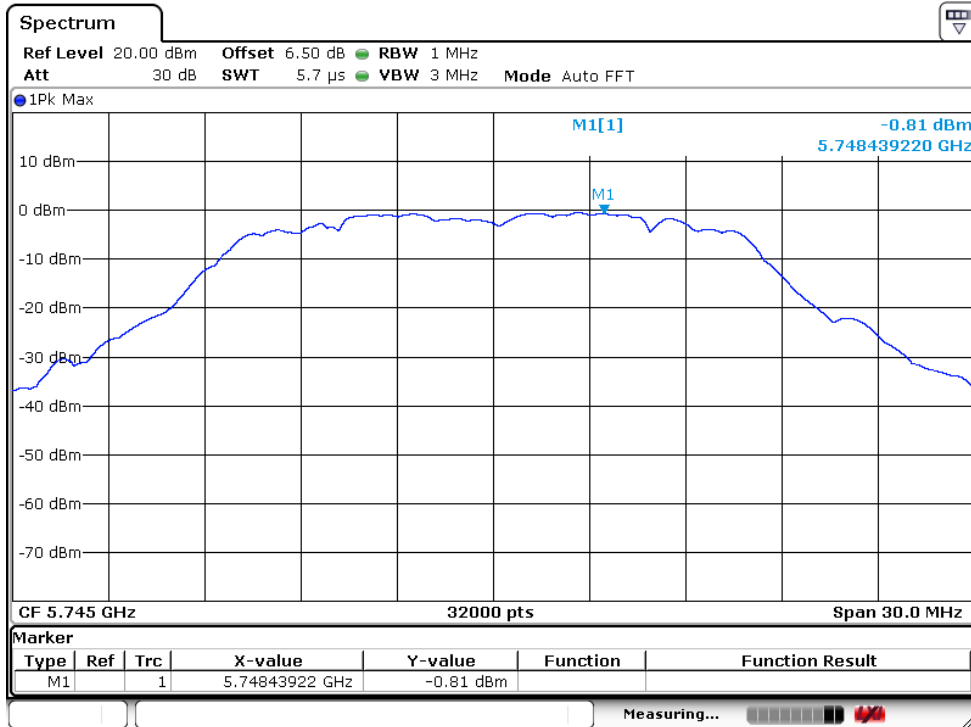

Channel: 157

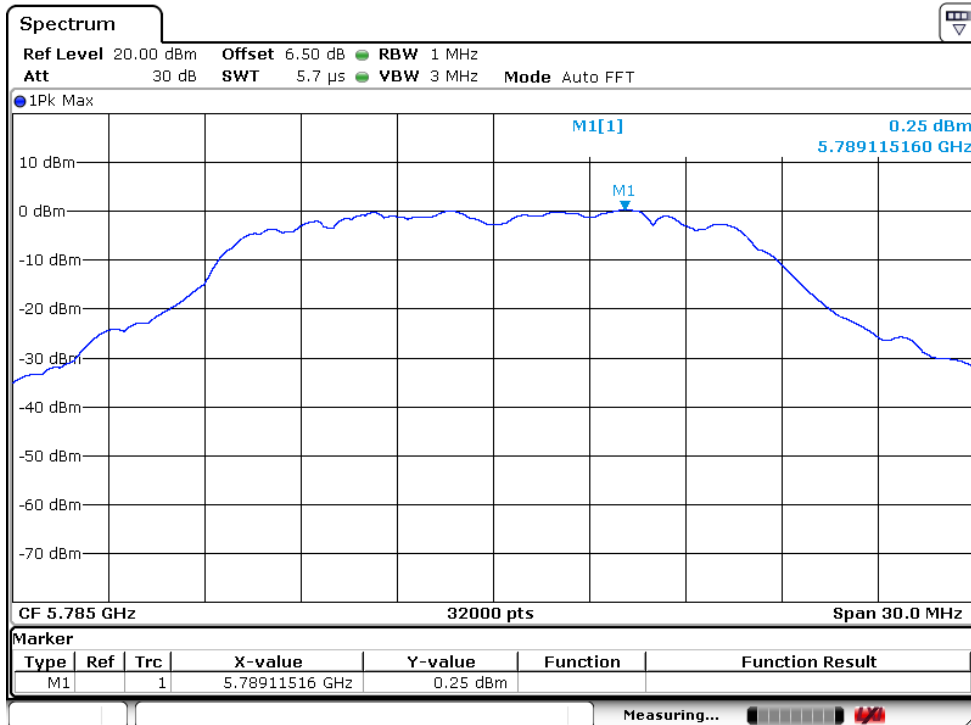

Channel: 165

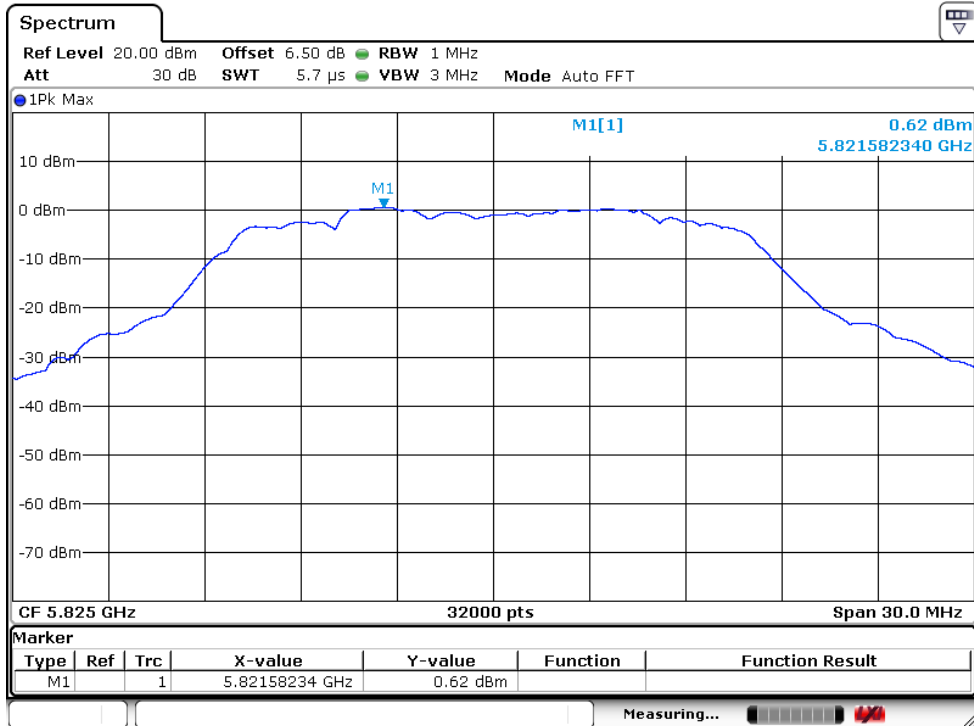

802.11n20 Channel: 149

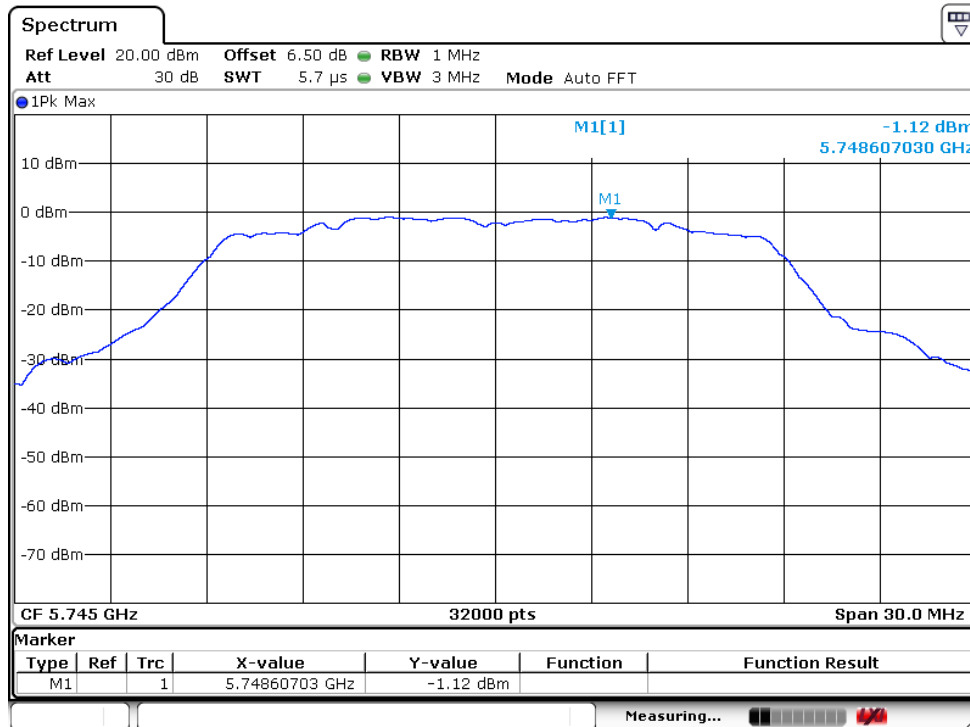

Channel: 157

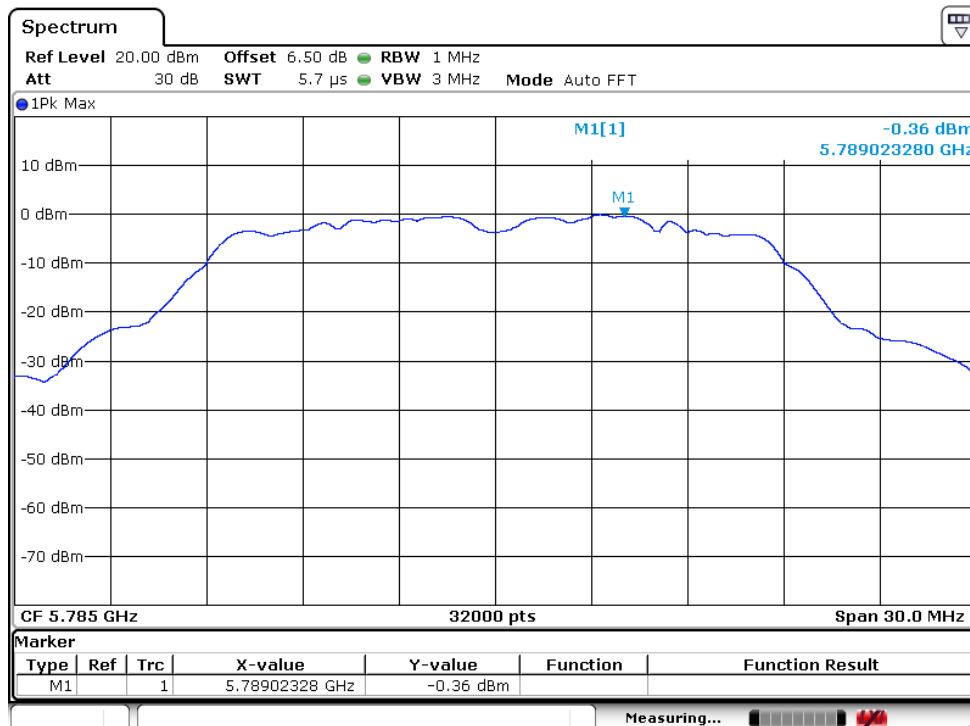

Channel: 165

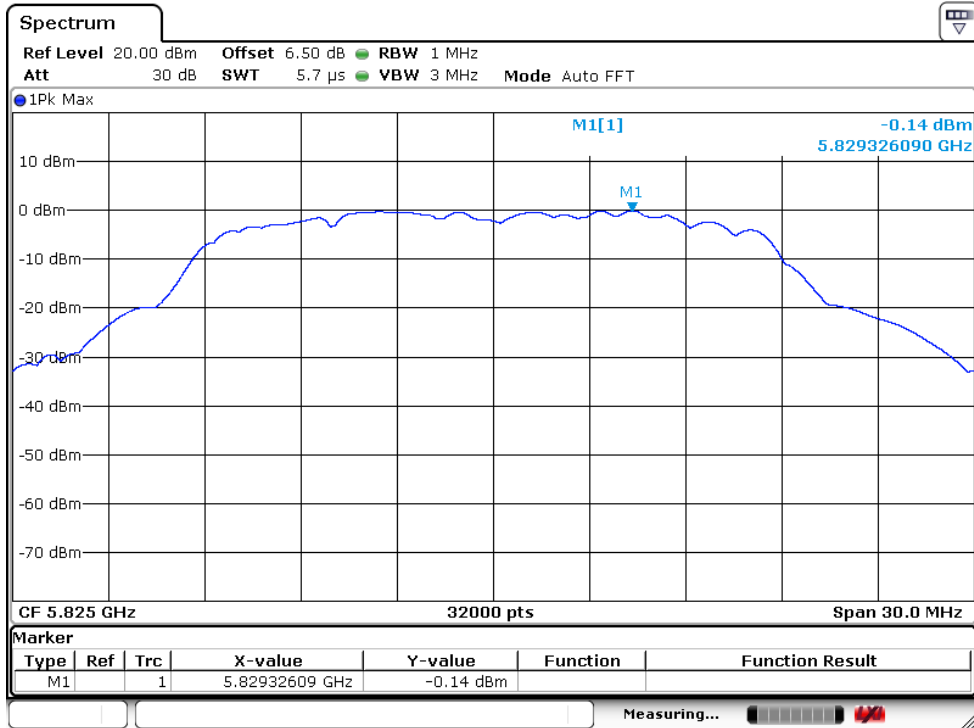

802.11ac20 Channel: 149

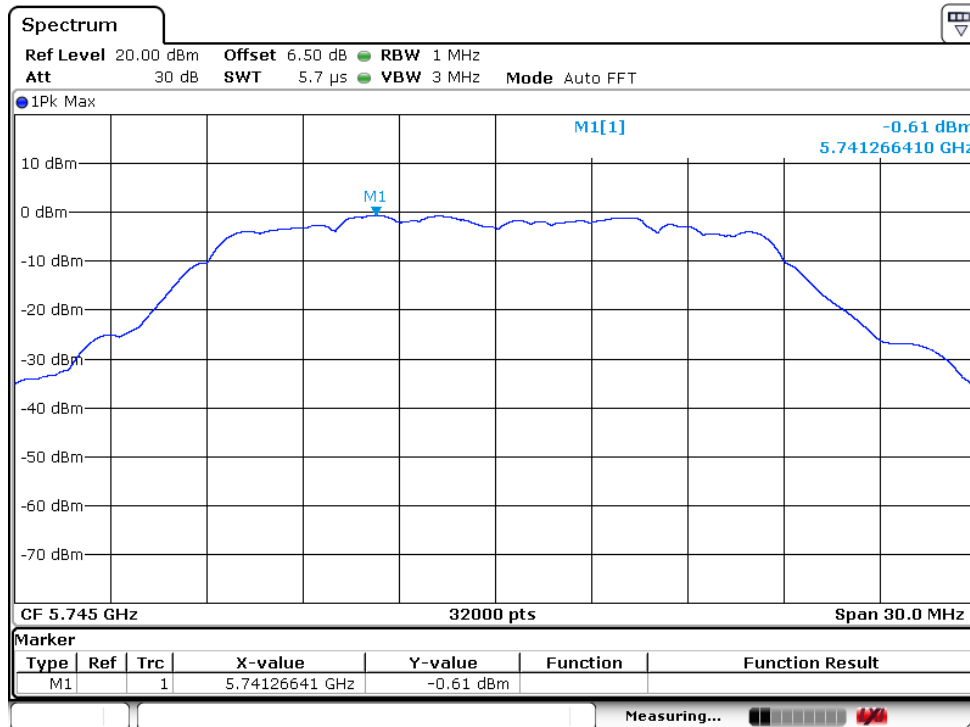

Channel: 157

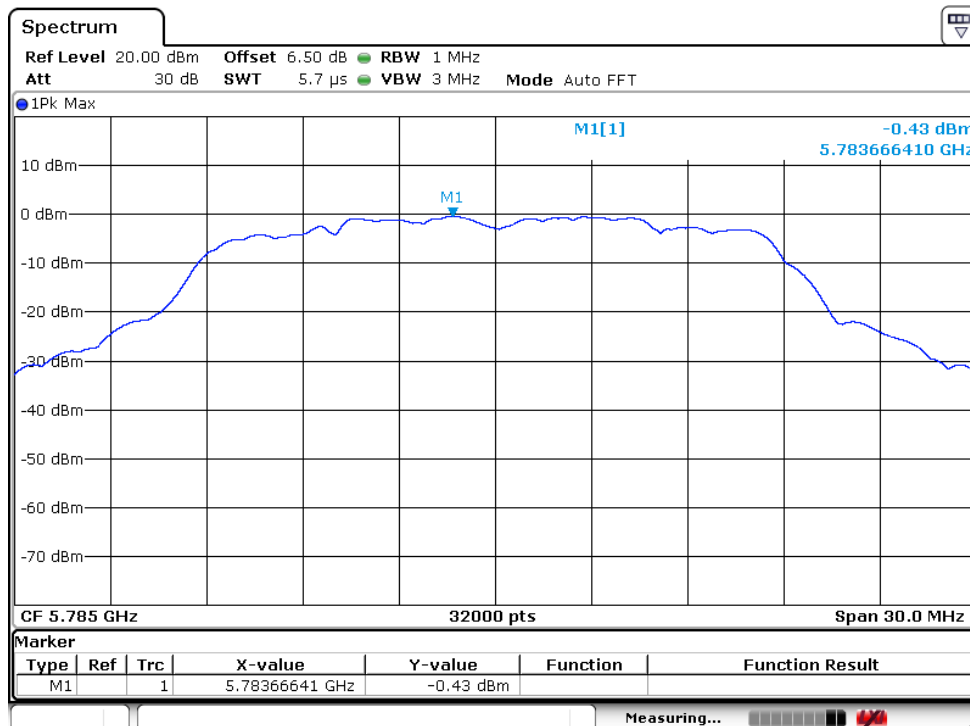

Channel: 165

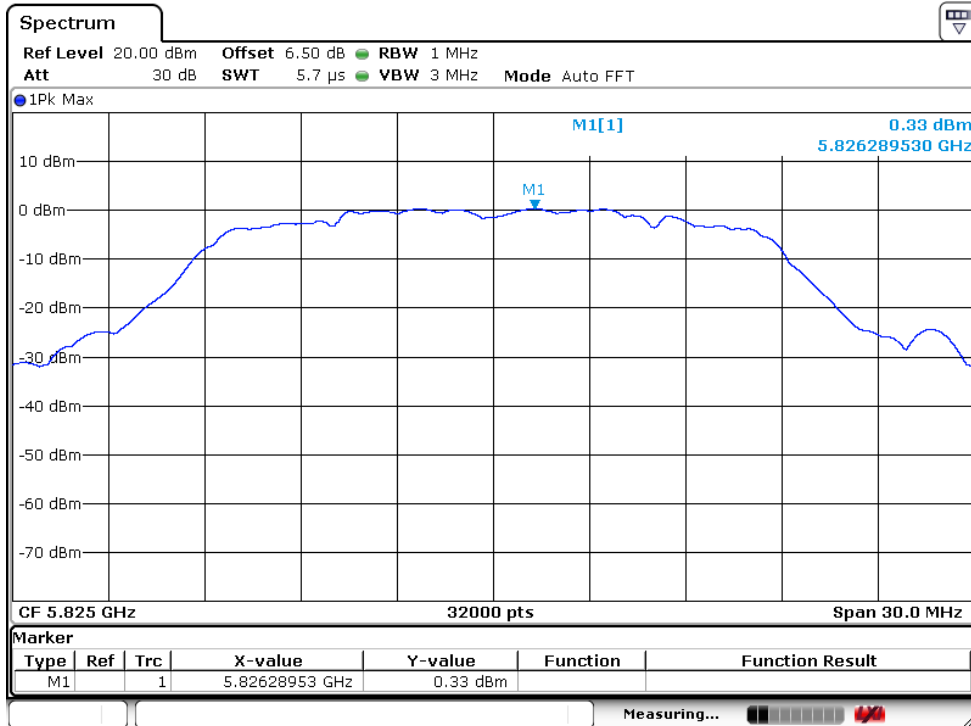

802.11n40 Channel: 38

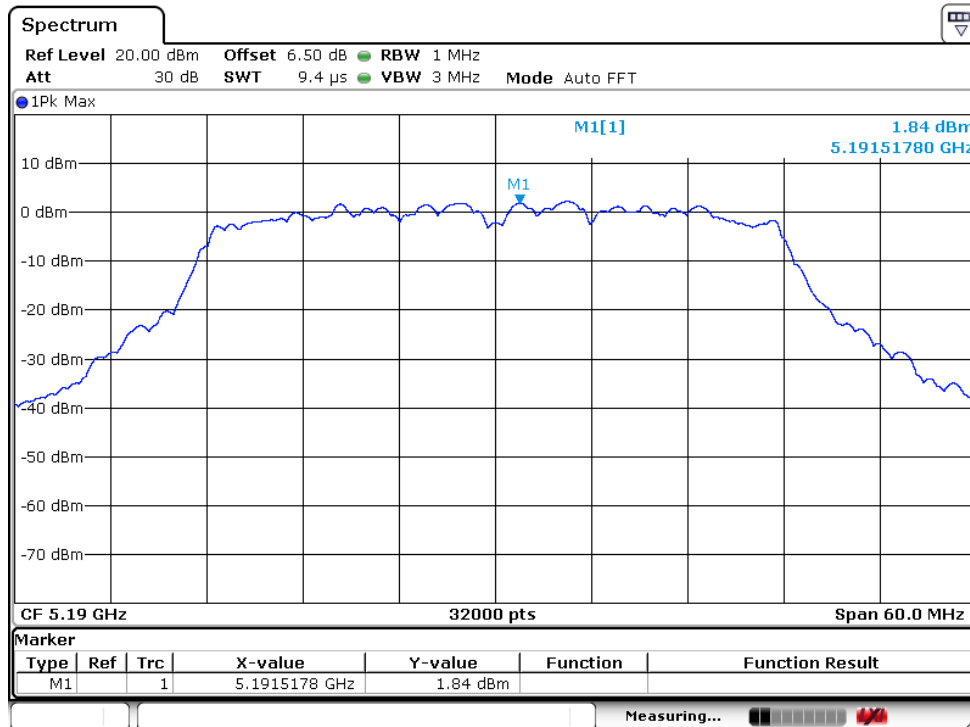

Channel: 46

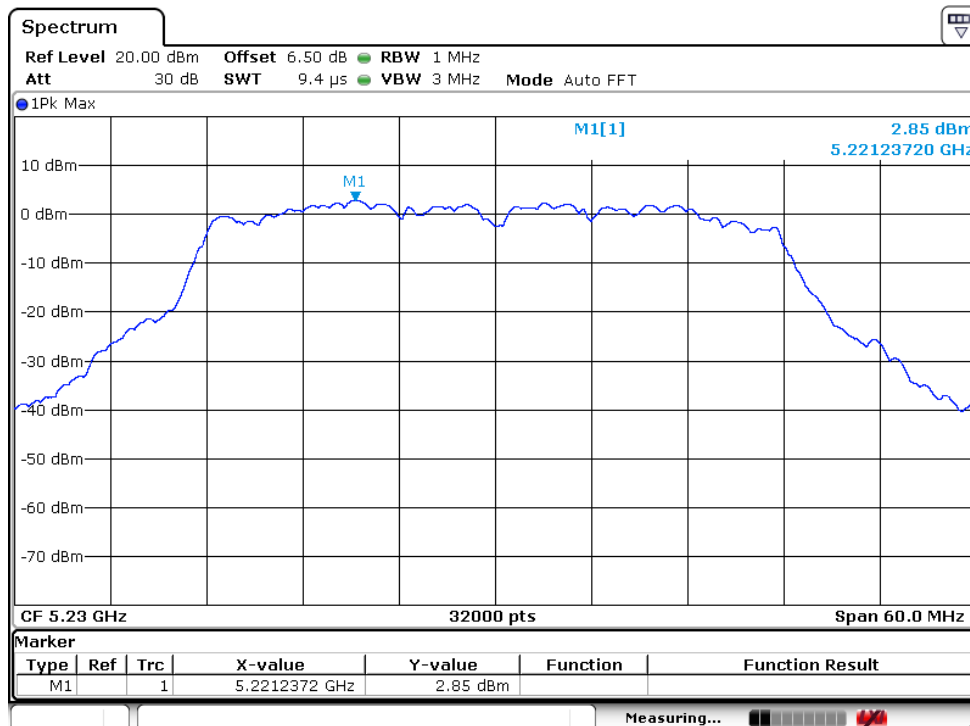

802.11ac40 Channel: 38

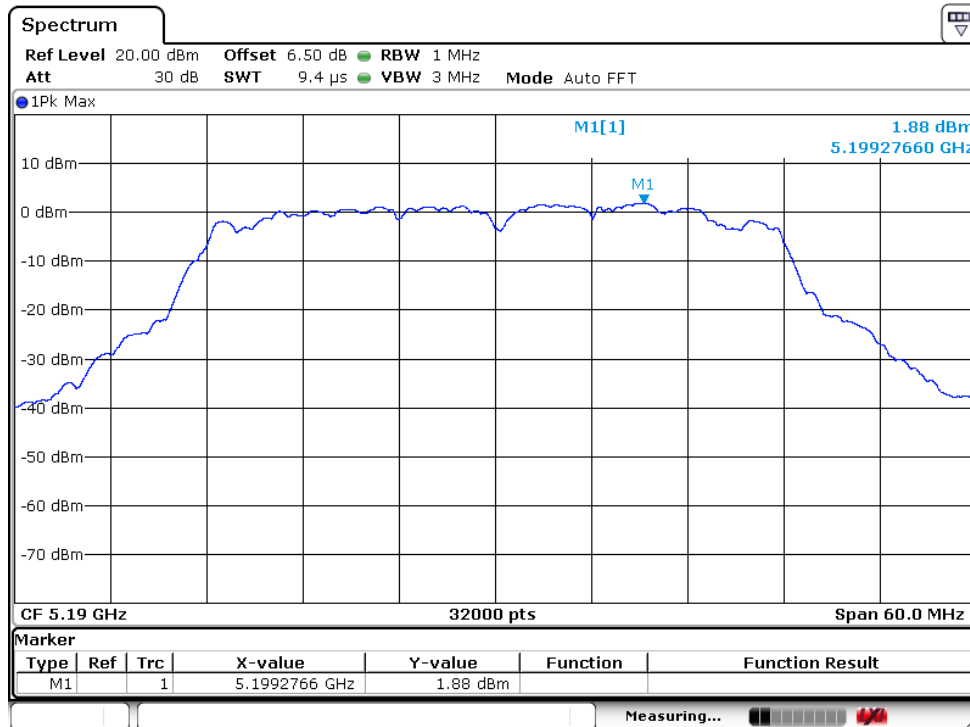

Channel: 46

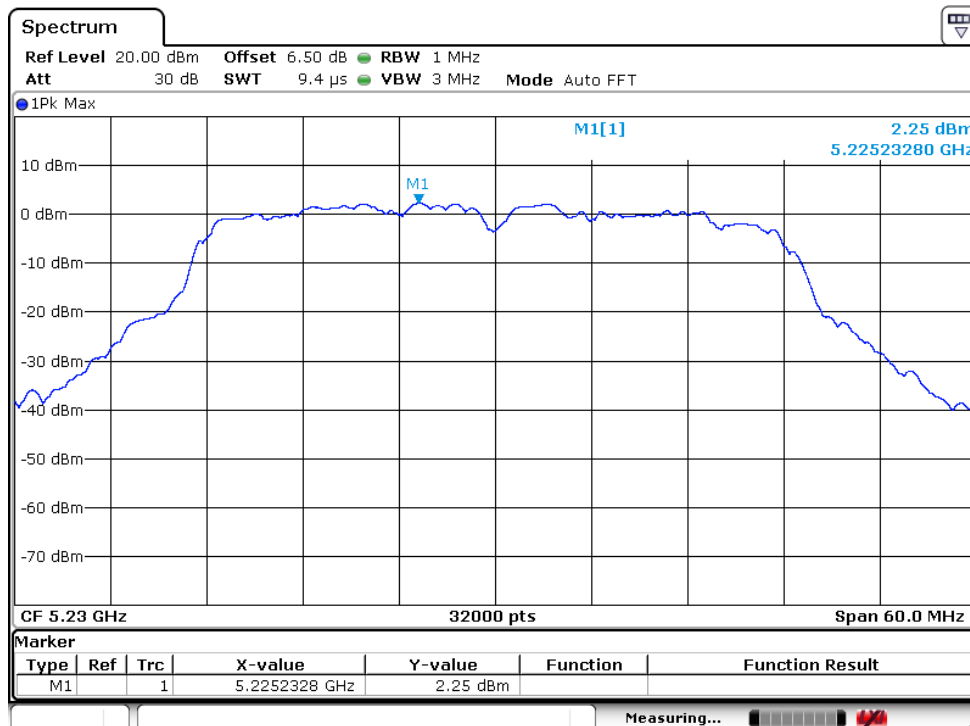

802.11n40 Channel: 151

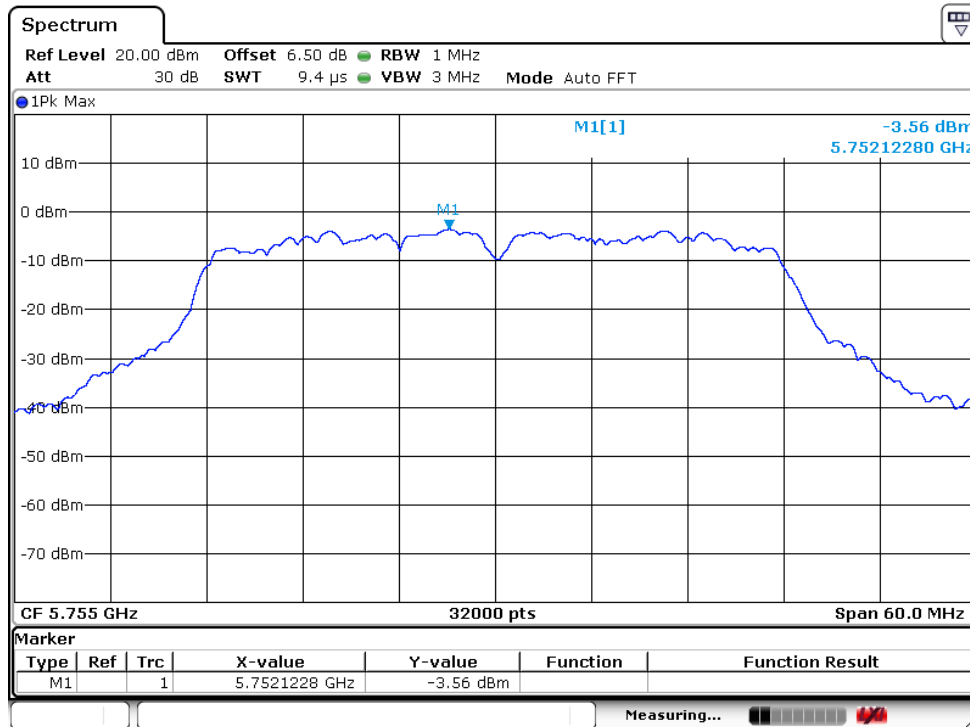

Channel: 159

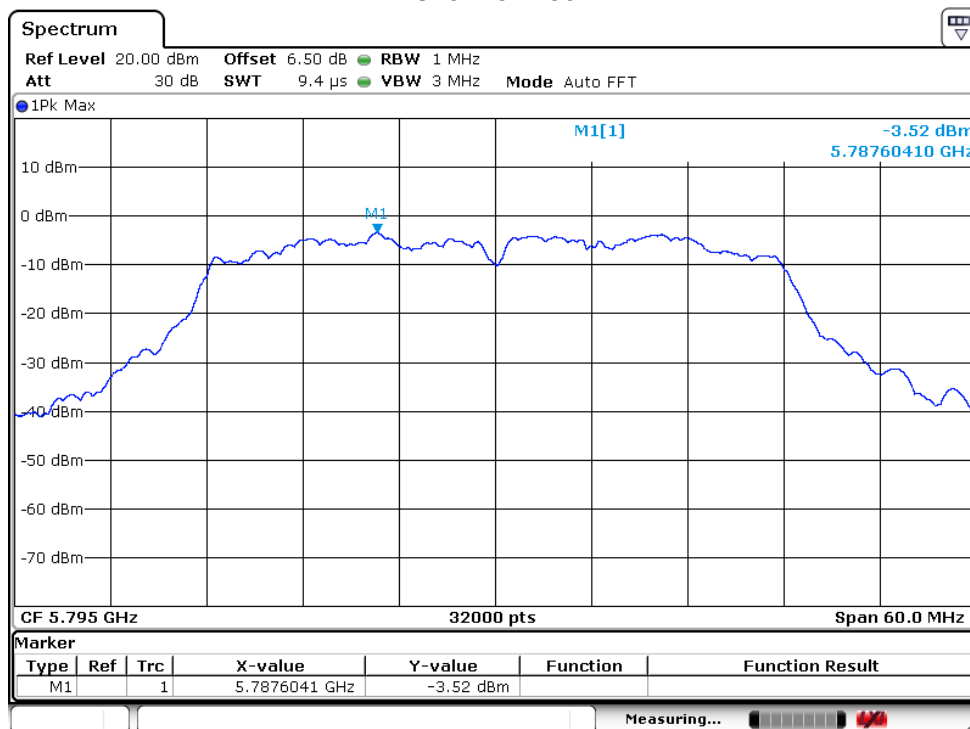

802.11ac40 Channel: 151

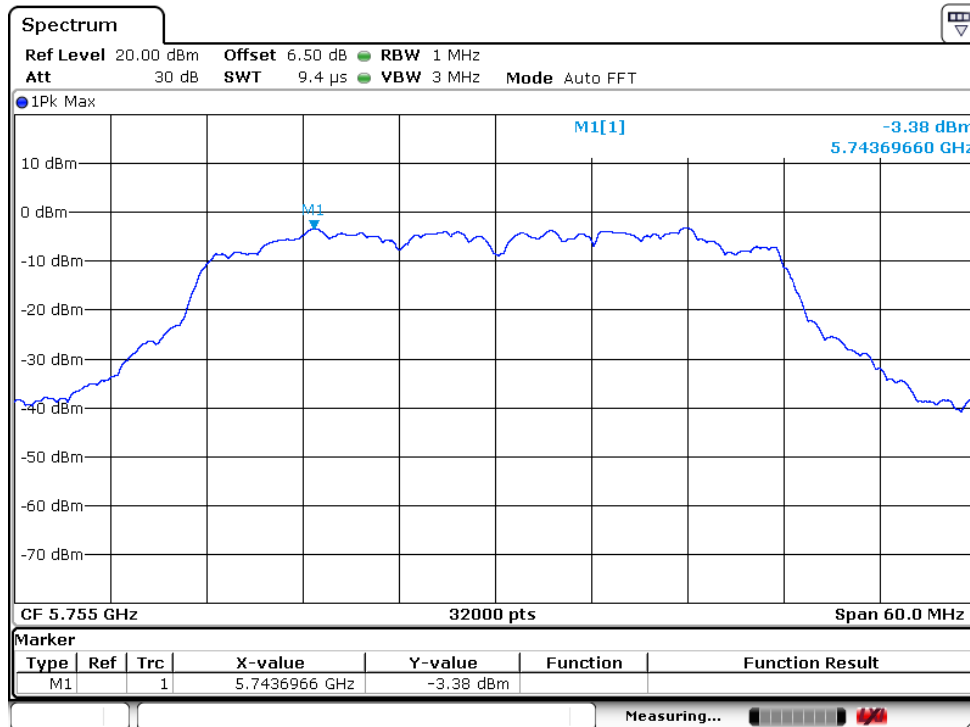

Channel: 159

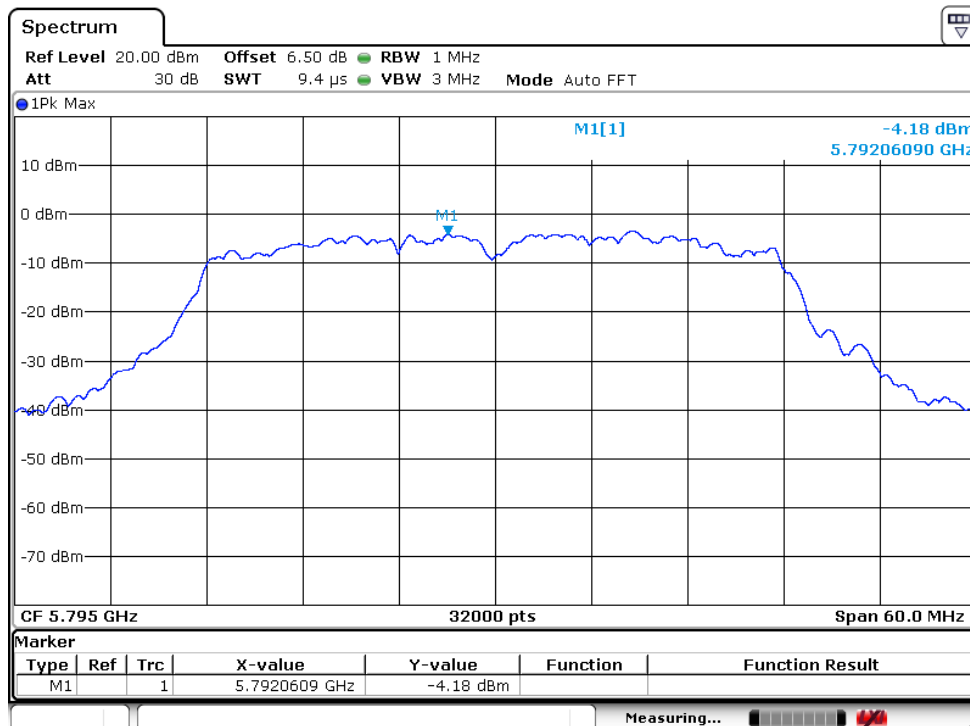

802.11ac80 Channel:42

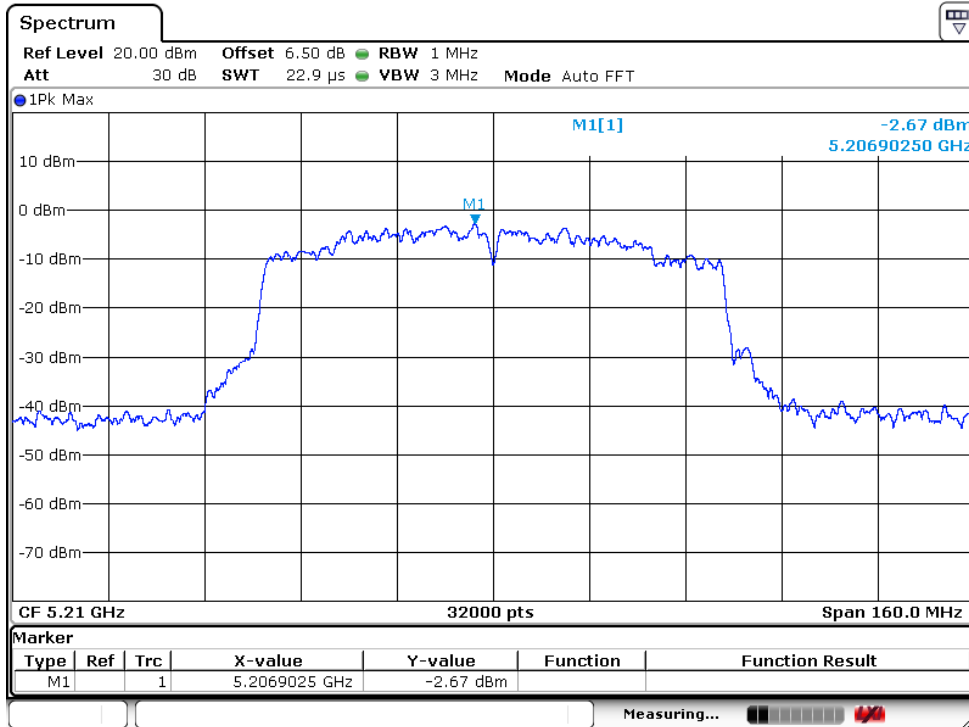

Channel: 155

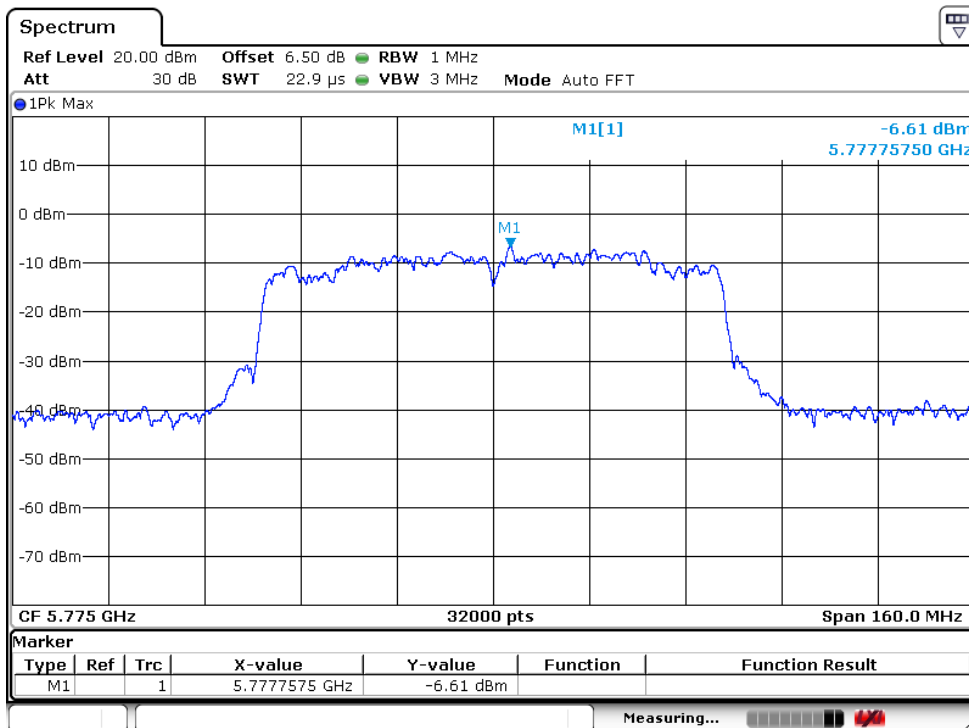

4. 26 dB & 99% Emission Bandwidth

4.1. TEST EQUIPMENT

Item	Equipment	Manufacturer	Model No.	Serial No.	Cal Due.	Cal. Interval
1	Spectrum analyzer	KEYSIGHT	N9010A	MY55150427	2019/05/25	1 Year
2	Attenuator	Mini-Circuits	BW-S10W2	101109	2018/12/17	1 Year
3	RF Cable	Micable	C10-01-01-1	100309	2018/12/17	1 Year
4	Spectrum analyzer	R&S	FSV40	101470	2019/06/28	1 Year

4.2. BLOCK DIAGRAM OF TEST SETUP

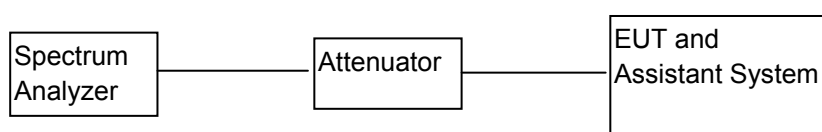

4.3. APPLIED PROCEDURES / LIMIT

The maximum power spectral density is measured as a conducted emission by direct connection of a calibrated test instrument to the equipment under test. If the device cannot be connected directly, alternative techniques acceptable to the Commission may be used. Measurements in the 5.725-5.85 GHz band are made over a reference bandwidth of 500 kHz or the 26 dB emission bandwidth of the device, whichever is less. Measurements in the 5.15-5.25 GHz, 5.25-5.35 GHz, and the 5.47-5.725 GHz bands are made over a bandwidth of 1 MHz or the 26 dB emission bandwidth of the device, whichever is less. A narrower resolution bandwidth can be used, provided that the measured power is integrated over the full reference bandwidth.

4.4. TEST PROCEDURE

- a) Set RBW = approximately 1% of the emission bandwidth.
- b) Set the VBW > RBW.
- c) Detector = Peak.
- d) Trace mode = max hold.
- e) Measure the maximum width of the emission that is 26 dB down from the maximum of the emission. Compare this with the RBW setting of the analyzer. Readjust RBW and repeat measurement as needed until the RBW/EBW ratio is approximately 1%.

The following procedure shall be used for measuring (99 %) power bandwidth:

1. Set center frequency to the nominal EUT channel center frequency.
2. Set span = 1.5 times to 5.0 times the OBW.
3. Set RBW = 1 % to 5 % of the OBW
4. Set VBW ≥ 3 · RBW
5. Video averaging is not permitted. Where practical, a sample detection and single sweep mode shall be used. Otherwise, peak detection and max hold mode (until the trace stabilizes) shall be used.

6. Use the 99 % power bandwidth function of the instrument (if available).
7. If the instrument does not have a 99 % power bandwidth function, the trace data points are recovered and directly summed in power units. The recovered amplitude data points, beginning at the lowest frequency, are placed in a running sum until 0.5 % of the total is reached; that frequency is recorded as the lower frequency. The process is repeated until 99.5 % of the total is reached; that frequency is recorded as the upper frequency. The 99% occupied bandwidth is the difference between these two frequencies.

4.5. TEST RESULT

CH. No.	Frequency (MHz)	26dB Occupied Bandwidth (MHz)			99% Occupied Bandwidth (MHz)		
		802.11a	802.11n (HT20)	802.11ac (VHT20)	802.11a	802.11n (HT20)	802.11ac (VHT20)
36	5180.00	22.44	24.52	24.33	16.46	16.40	17.68
40	5200.00	22.57	23.64	23.85	16.49	17.66	17.66
48	5240.00	23.36	23.36	24.19	16.56	17.68	17.65
CH. No.	Frequency (MHz)	6dB Occupied Bandwidth (MHz)			99% Occupied Bandwidth (MHz)		
		802.11a	802.11n (HT20)	802.11ac (VHT20)	802.11a	802.11n (HT20)	802.11ac (VHT20)
149	5745.00	15.12	15.32	15.12	16.40	17.58	17.59
157	5785.00	15.11	15.12	15.11	16.44	17.61	17.60
165	5825.00	15.12	15.12	15.12	16.42	17.58	17.60

CH. No.	Frequency (MHz)	26dB Occupied Bandwidth (MHz)		99% Occupied Bandwidth (MHz)	
		802.11n(HT40)	802.11ac(VHT40)	802.11n(HT40)	802.11ac(VHT40)
38	5190.00	43.81	43.42	36.14	36.18
46	5230.00	43.02	43.53	36.12	36.17
CH. No.	Frequency (MHz)	6B Occupied Bandwidth (MHz)		99% Occupied Bandwidth (MHz)	
		802.11n(HT40)	802.11ac(VHT40)	802.11n(HT40)	802.11ac(VHT40)
151	5755.00	35.08	34.77	36.08	36.06
159	5795.00	35.08	35.08	36.05	36.06

CH. No.	Frequency (MHz)	26dB Occupied Bandwidth (MHz)	99% Occupied Bandwidth (MHz)
		802.11ac(VHT80)	802.11ac(VHT80)
42	5210	82.99	74.74
CH. No.	Frequency (MHz)	6dB Occupied Bandwidth (MHz)	99% Occupied Bandwidth (MHz)
		802.11ac(VHT80)	802.11ac(VHT80)
155	5775	75.03	75.23

Note: The worst data is Antenna A, only shown Antenna A Plot.

Test plots as followed: Antenna A
26dB BW 802.11a
Channel: 36

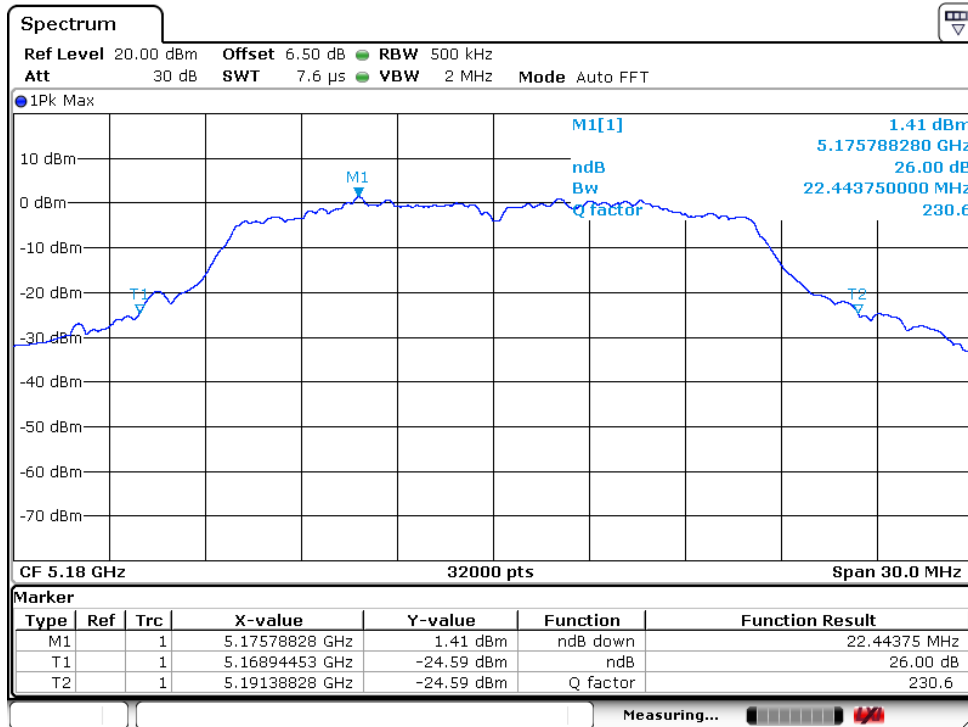

Channel: 40

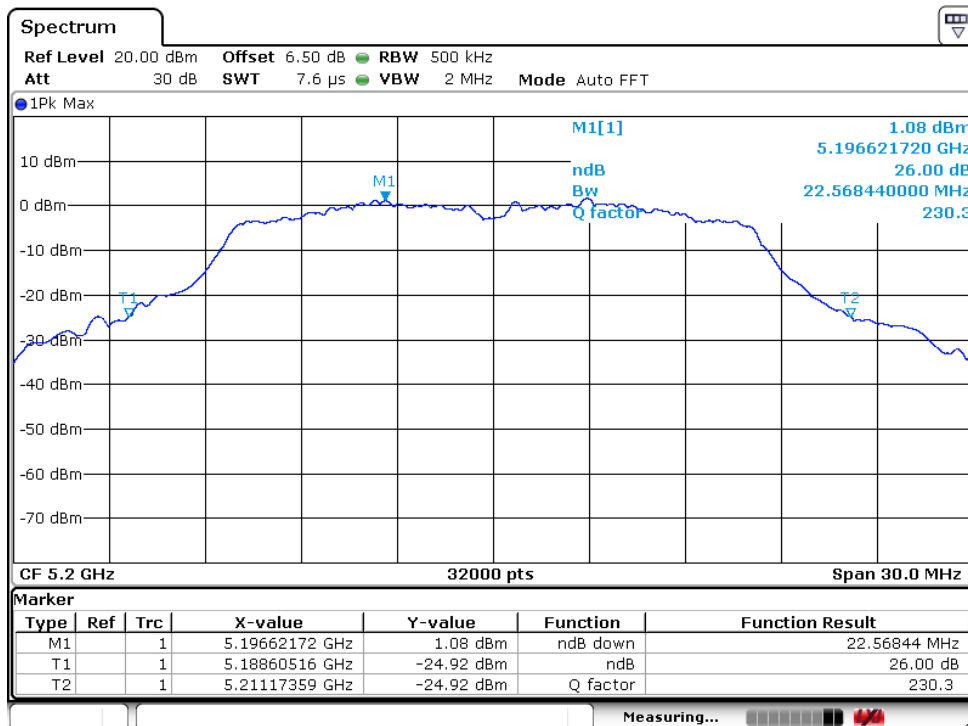

26dB BW 802.11n20 Channel: 36

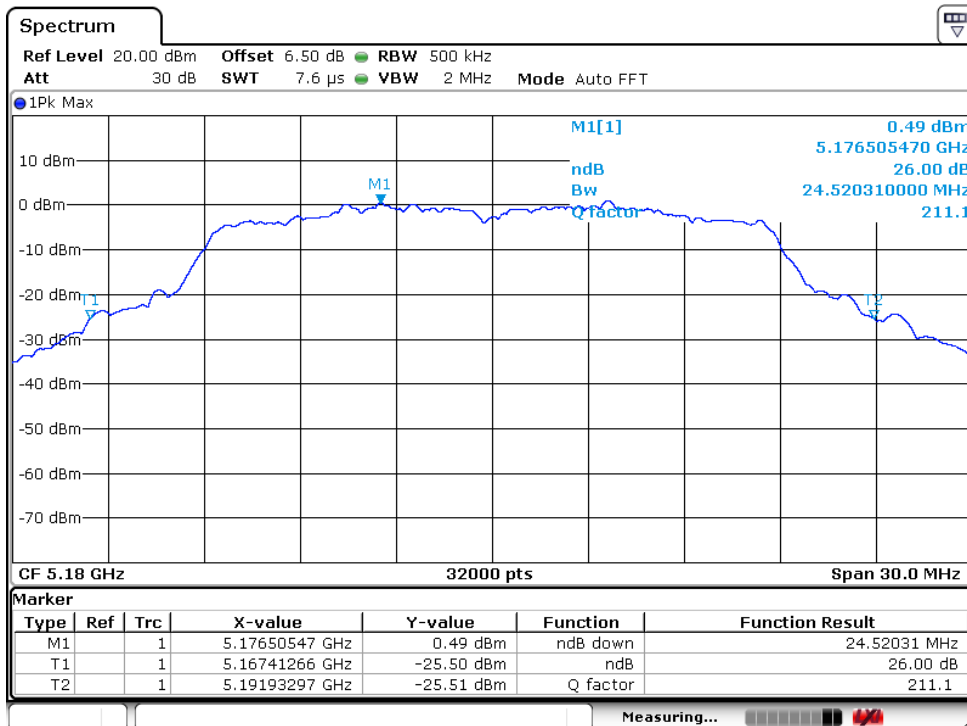

Channel: 40

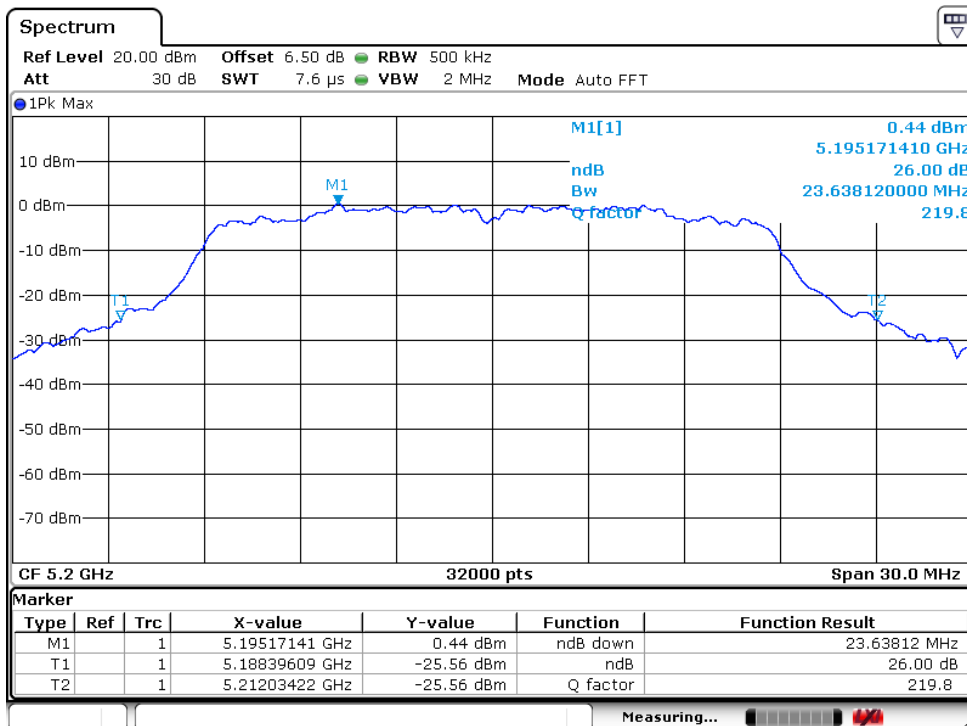

Channel: 48

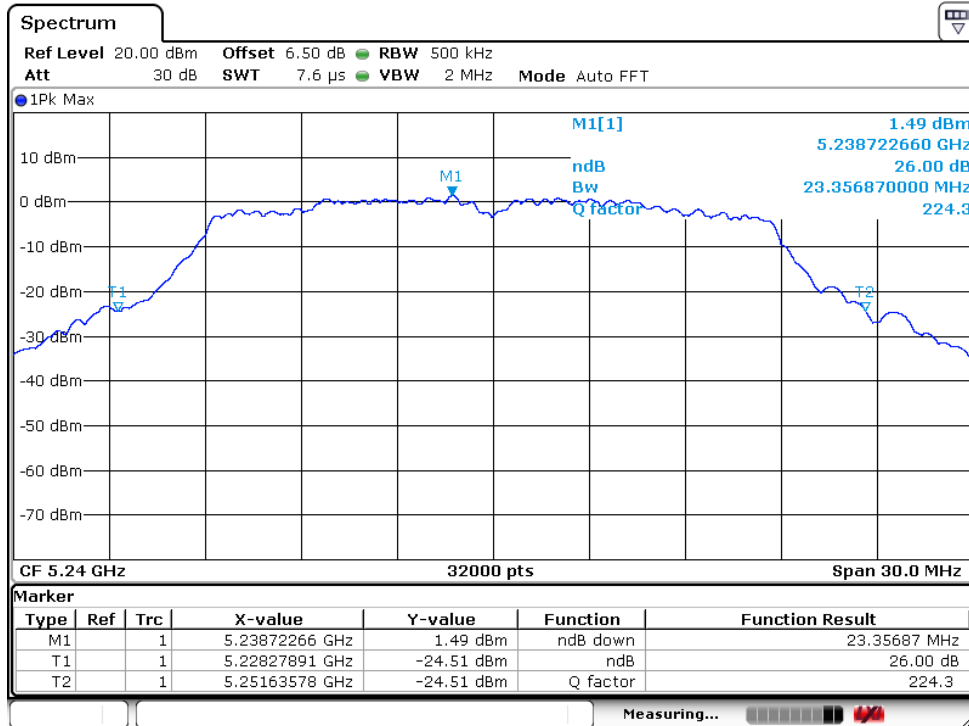

802.11ac20 Channel: 36

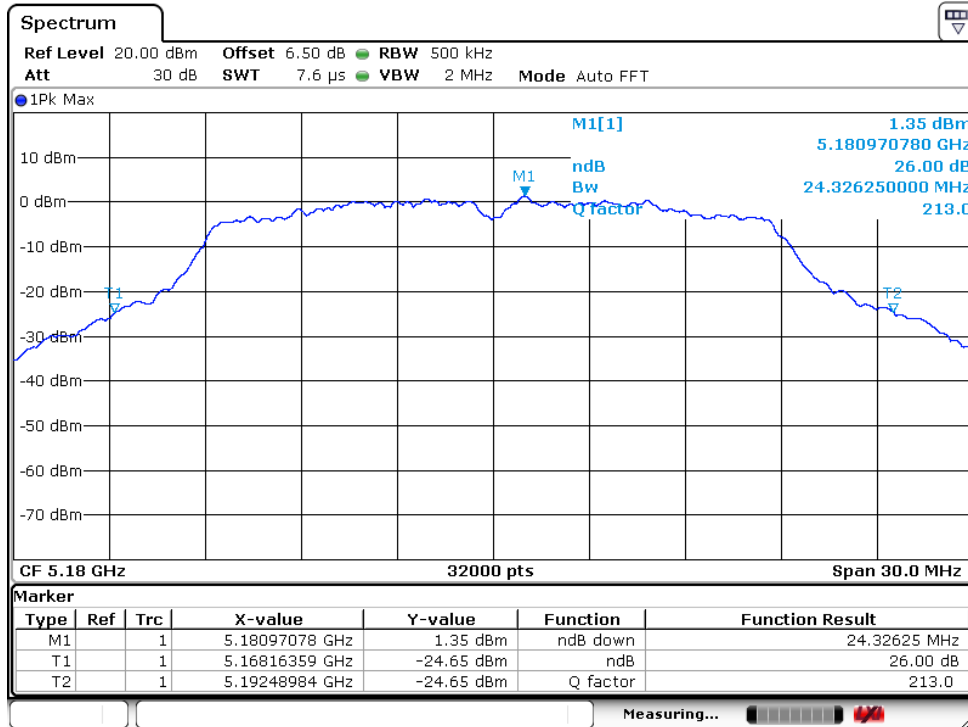

Channel: 40

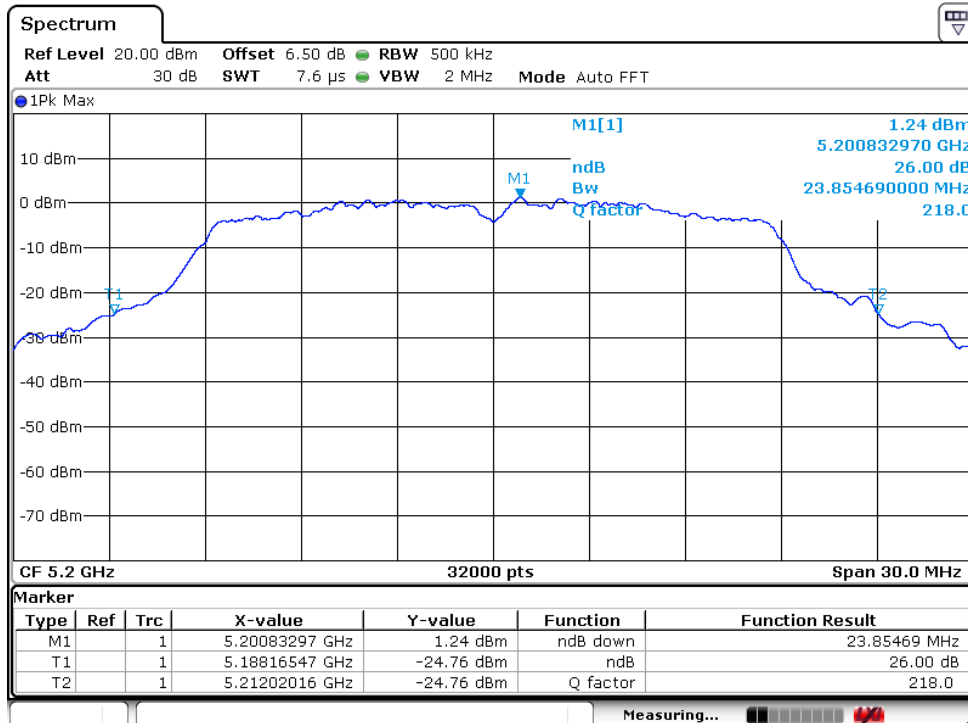

6dB BW 802.11a Channel: 149

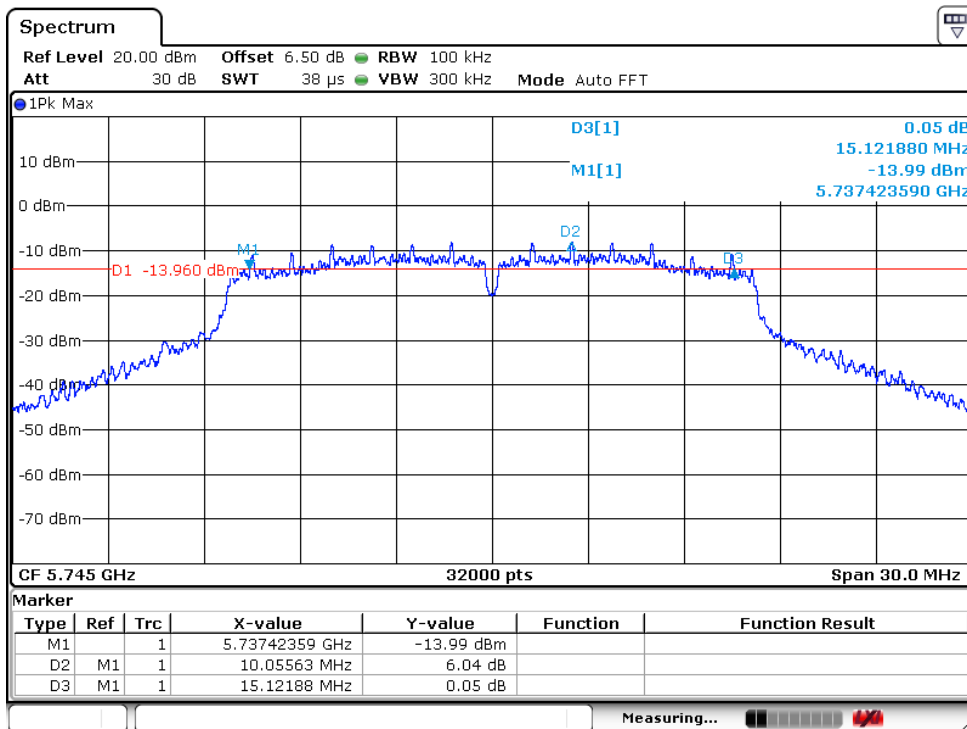

Channel: 157

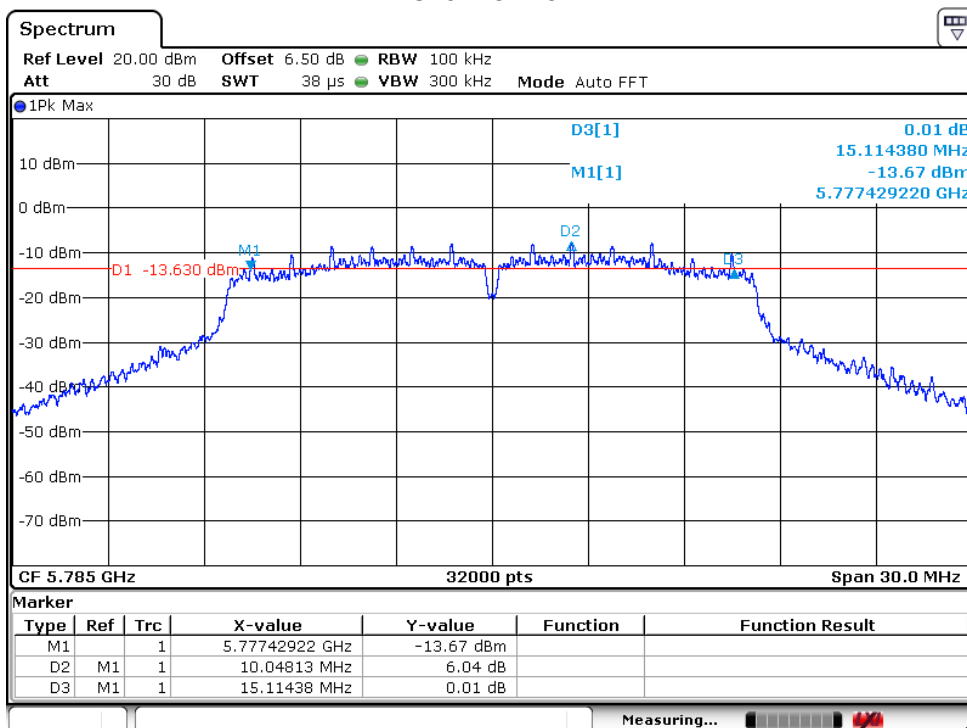

6dB BW 802.11n20 Channel: 149

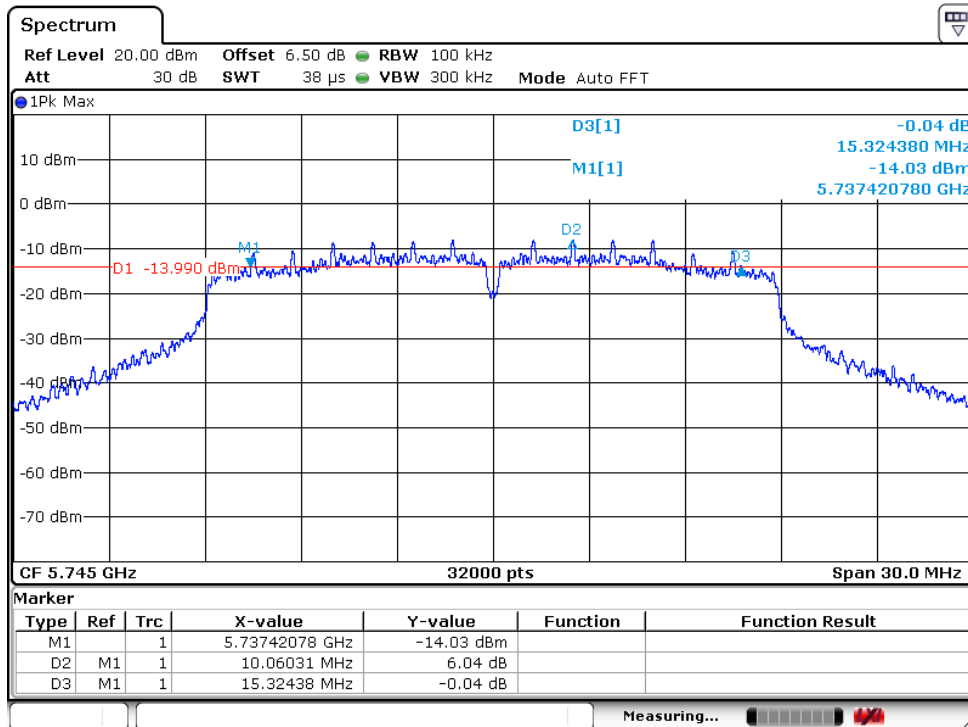

Channel: 157

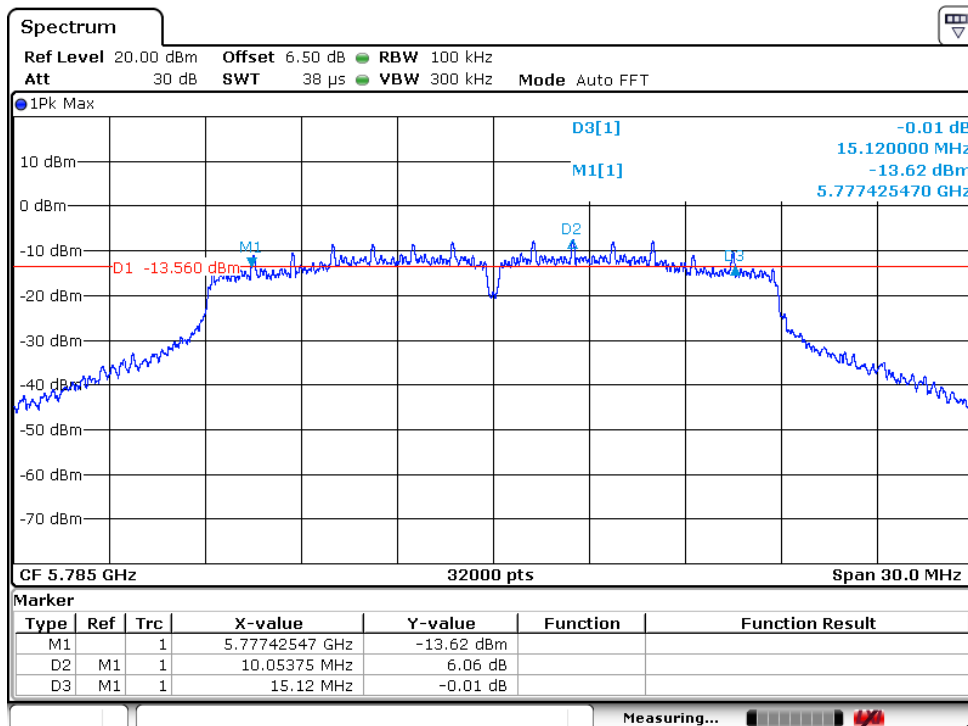

Channel: 165

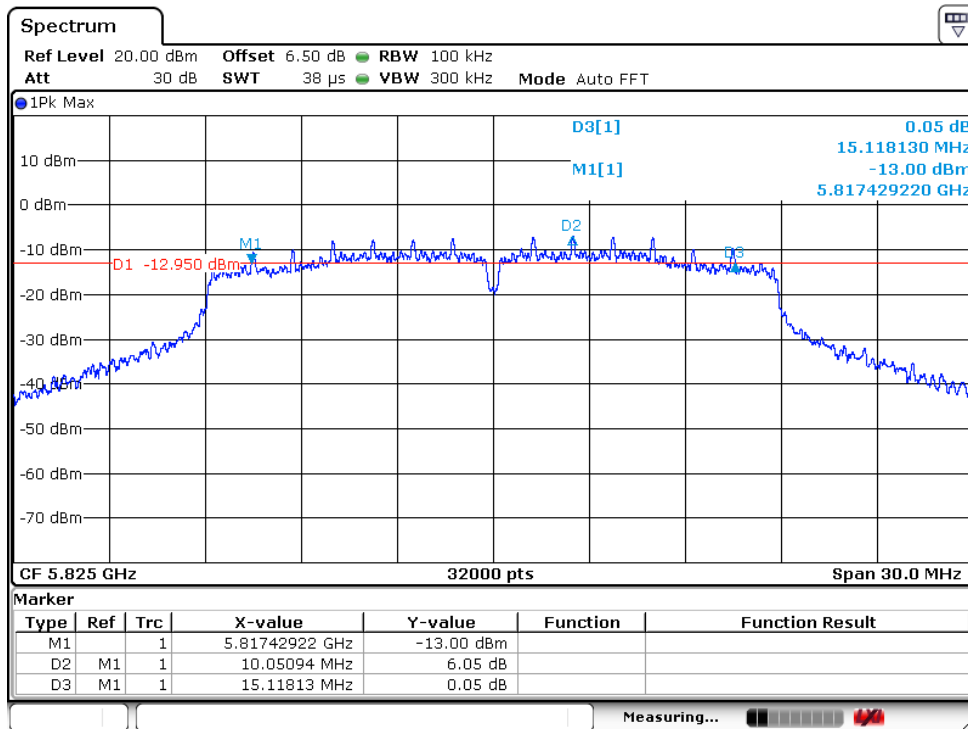

6dB BW 802.11ac20 Channel: 149

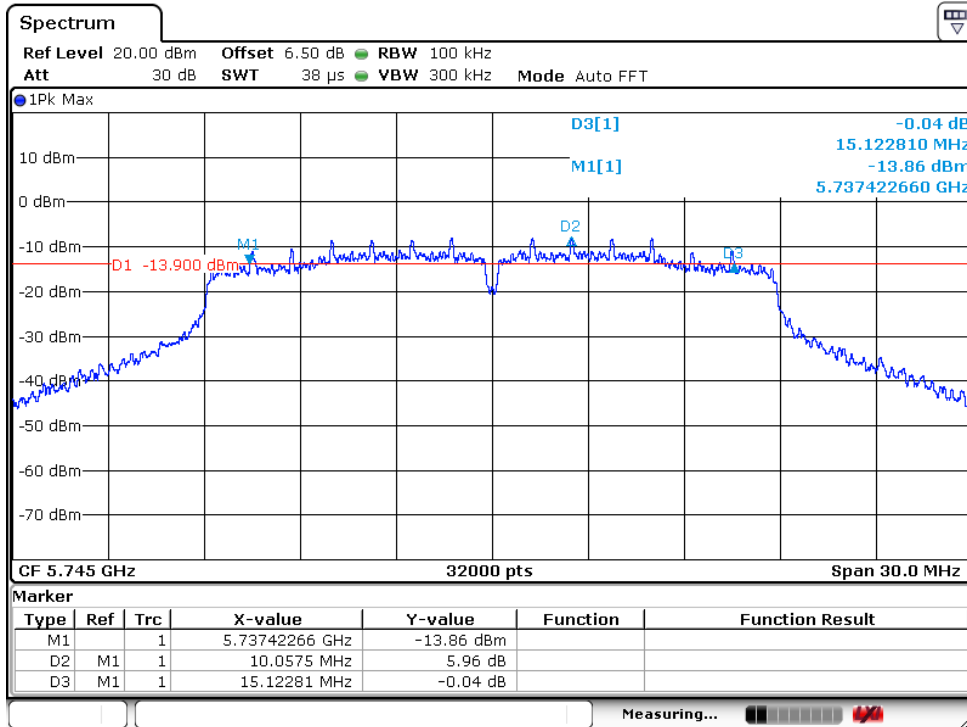

Channel: 157

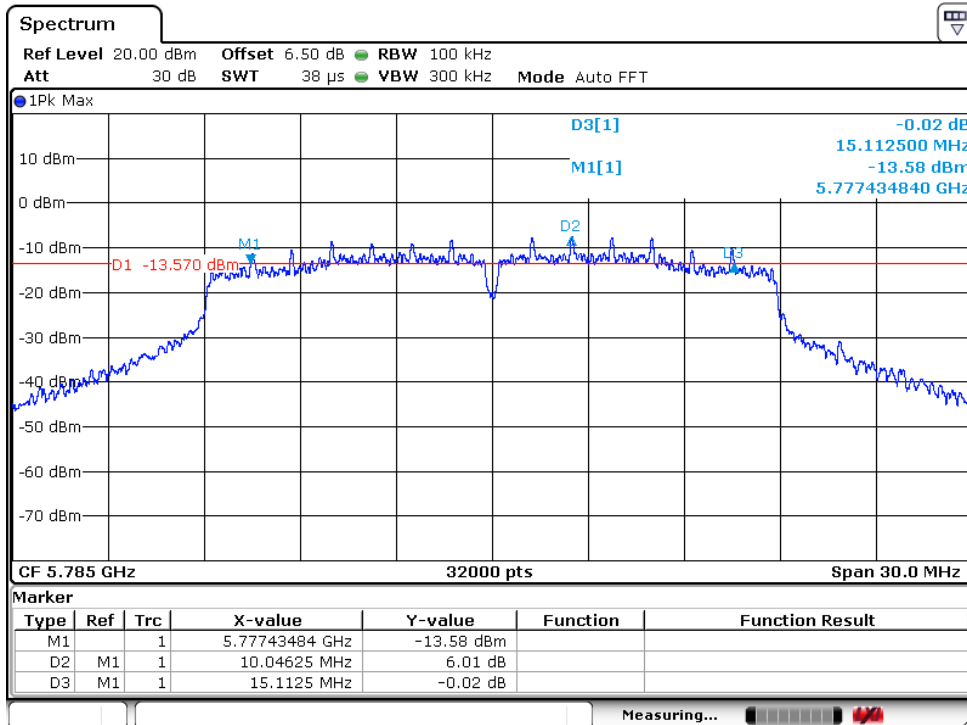

Channel: 165

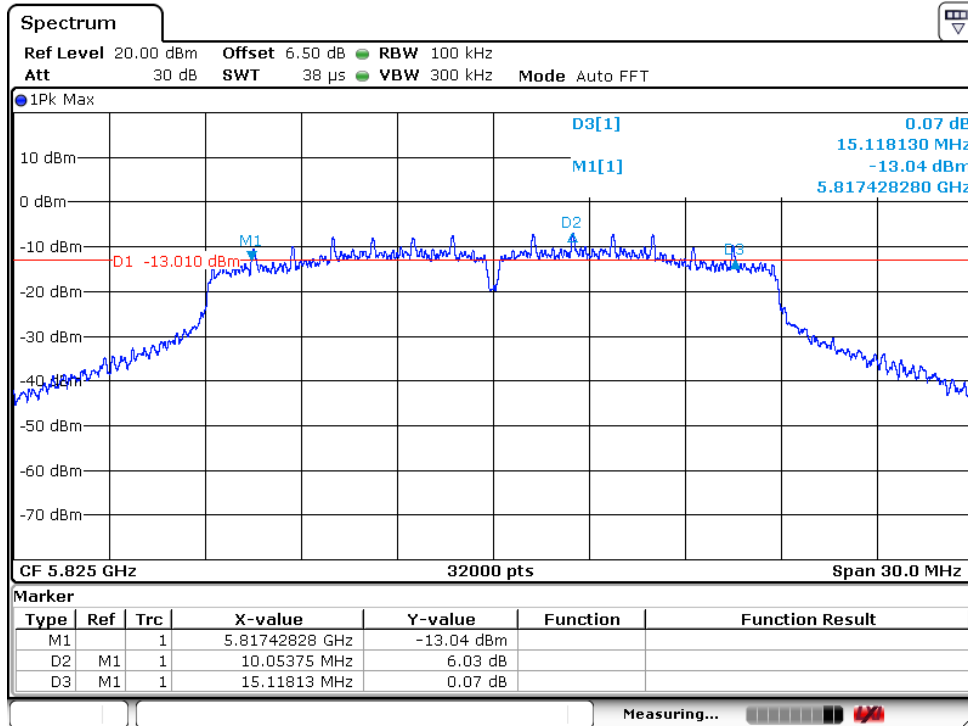

26dB BW 802.11n40 Channel: 38

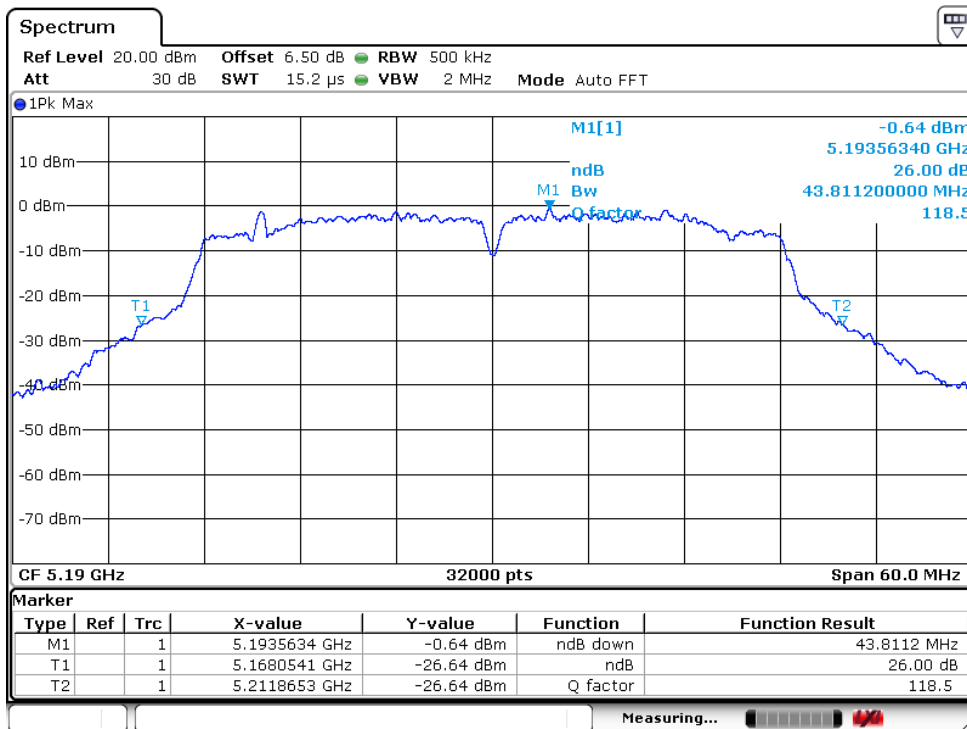

Channel: 46

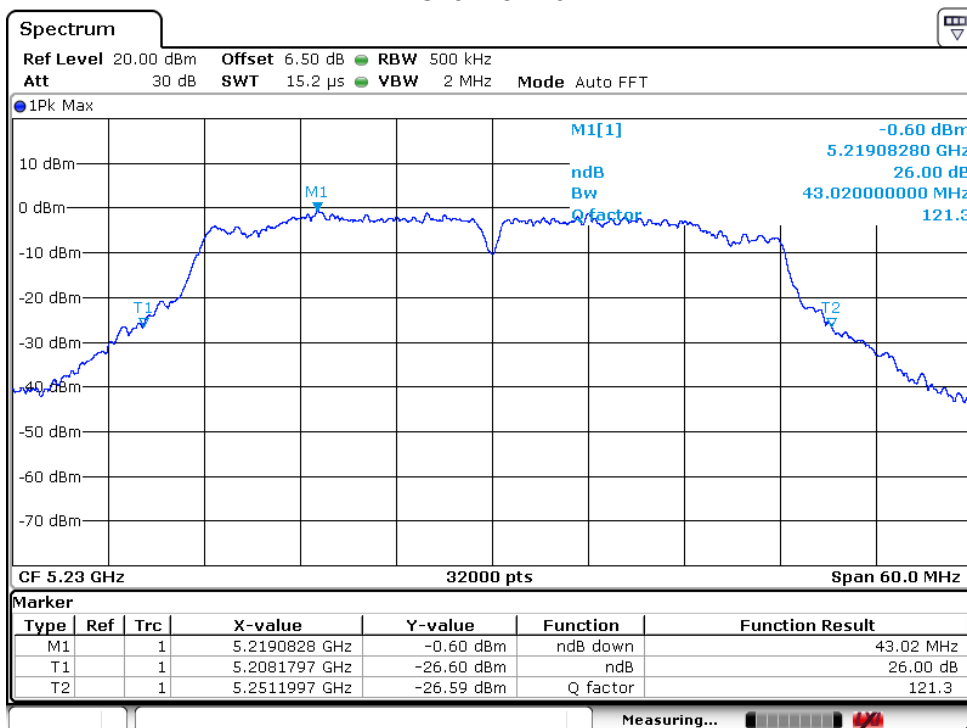

26dB BW 802.11ac40 Channel: 38

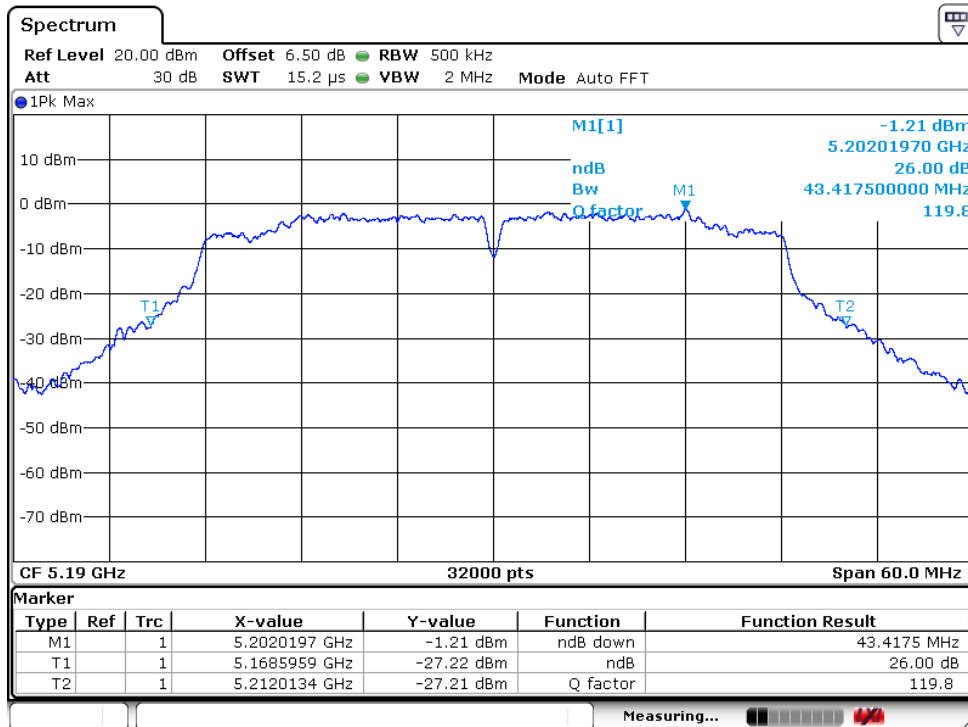

Channel: 46

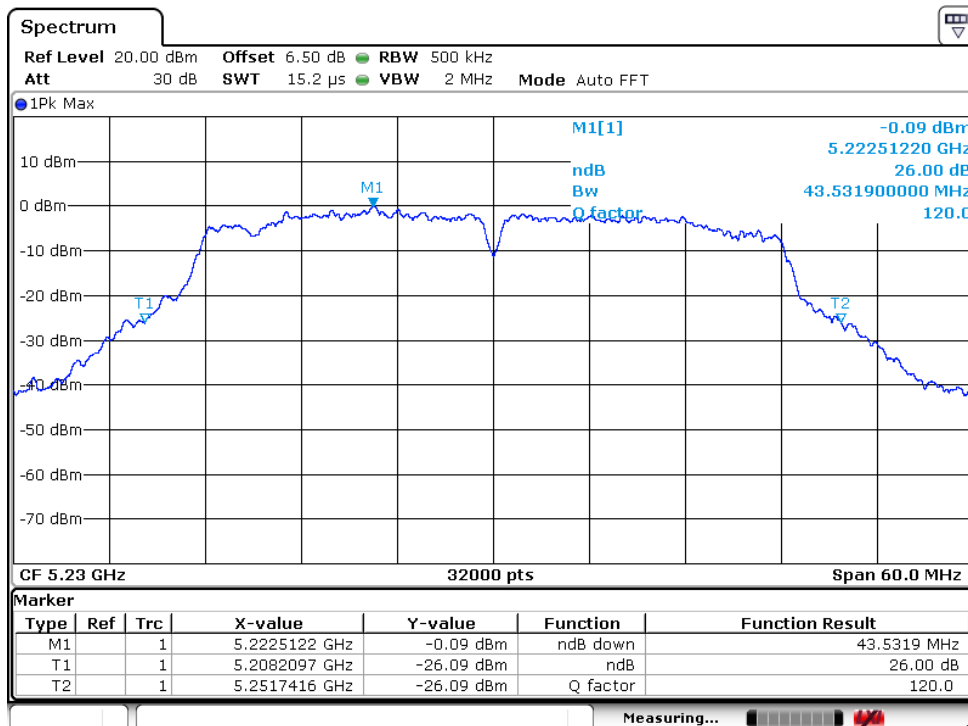

6dB BW 802.11n40 Channel: 151

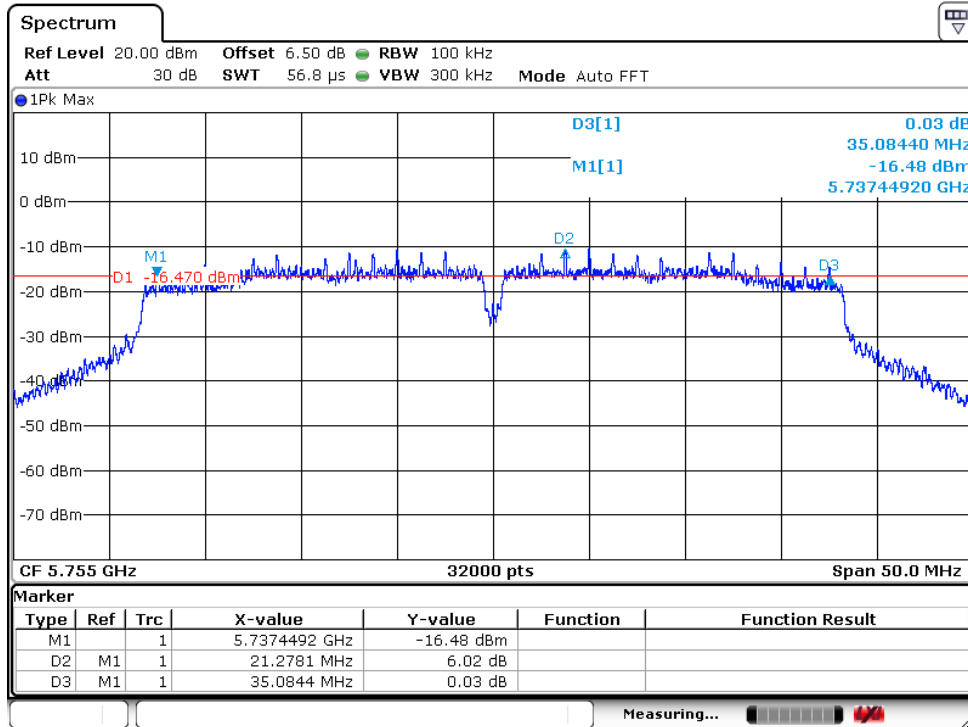

Channel: 159

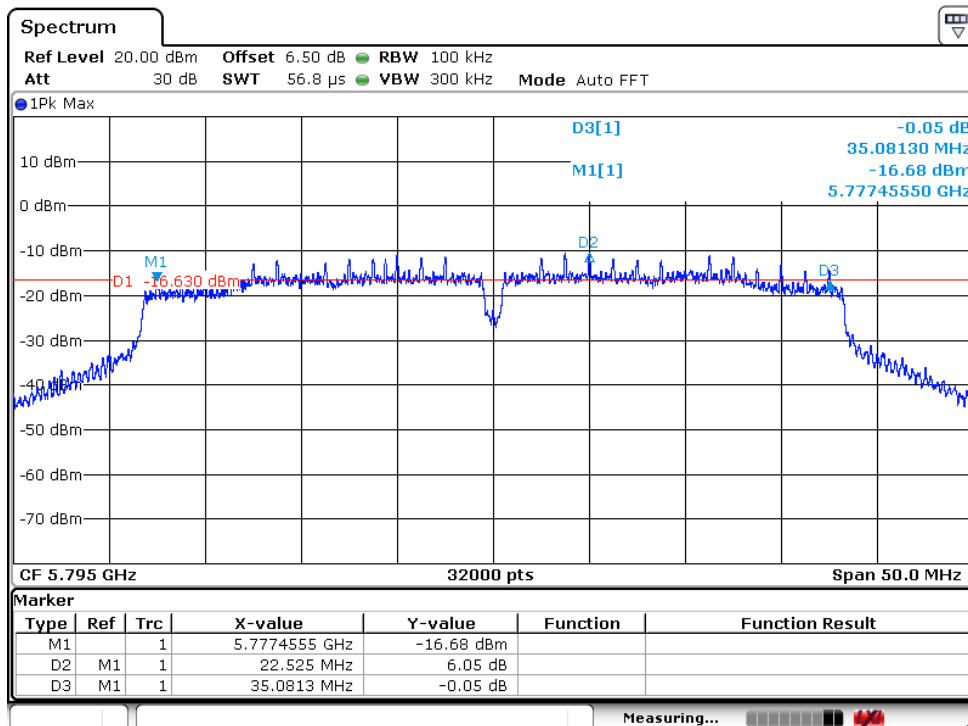

6dB BW 802.11ac40 Channel: 151

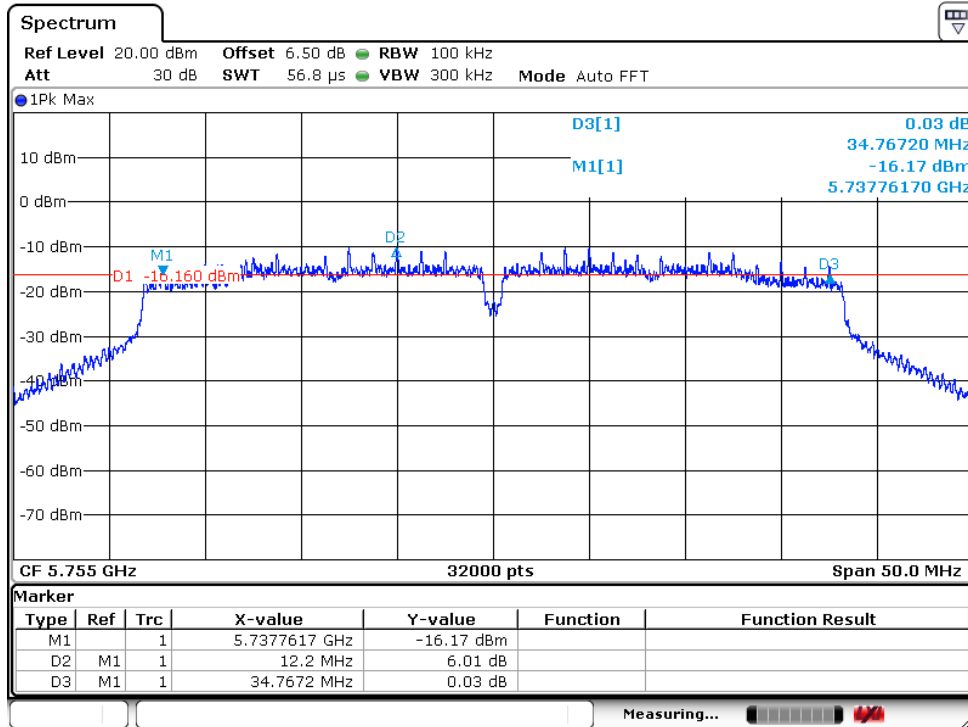

Channel: 159

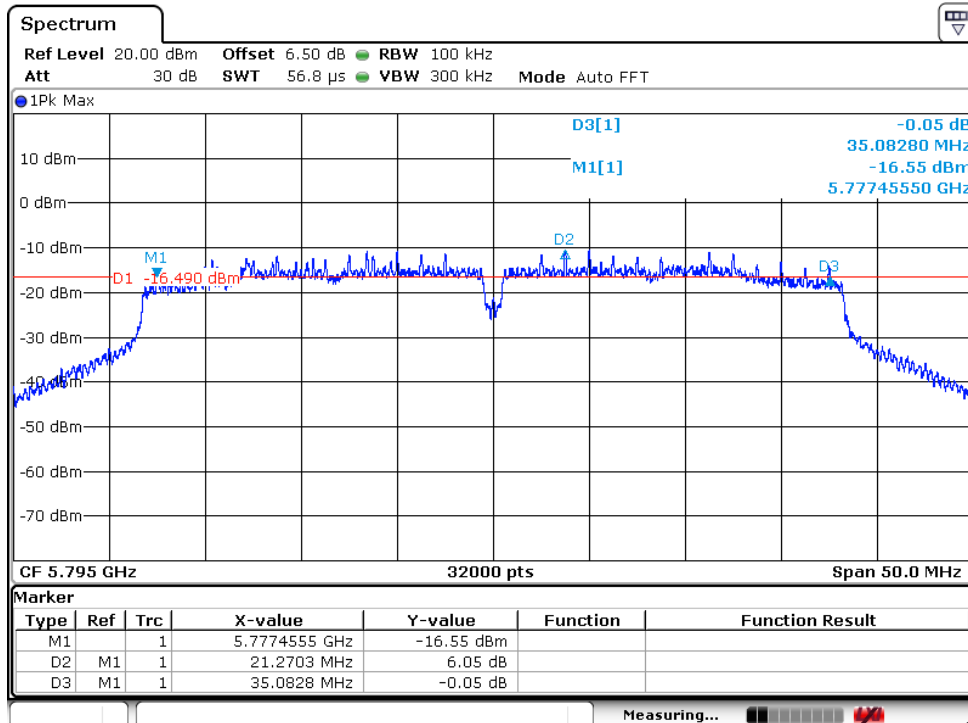

26dB BW 802.11ac80 Channel:42

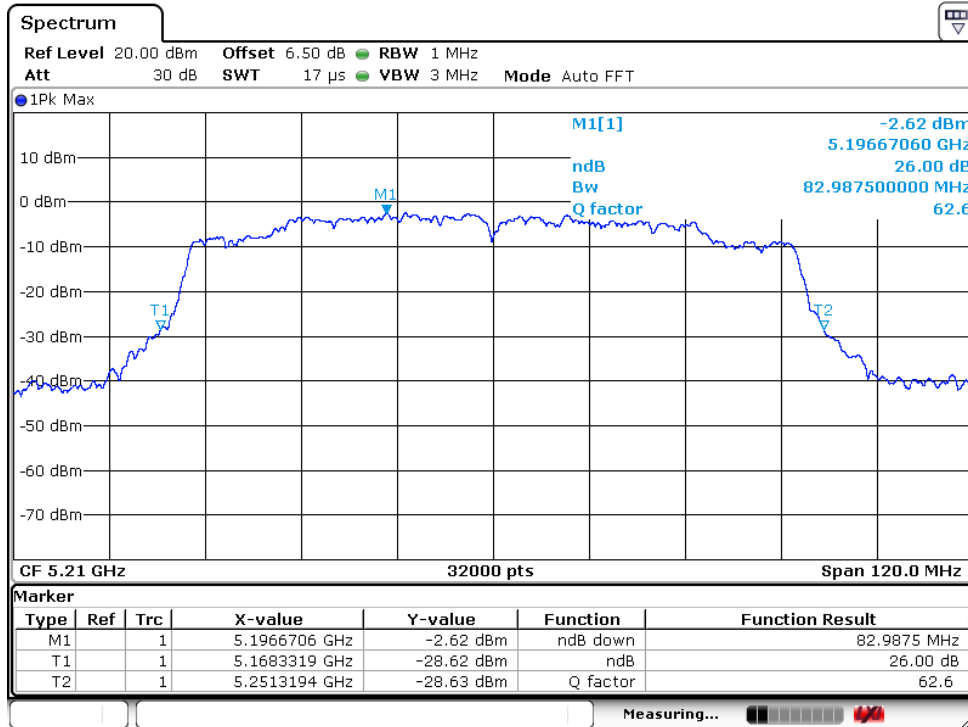

6dB BW 802.11ac80 Channel: 155

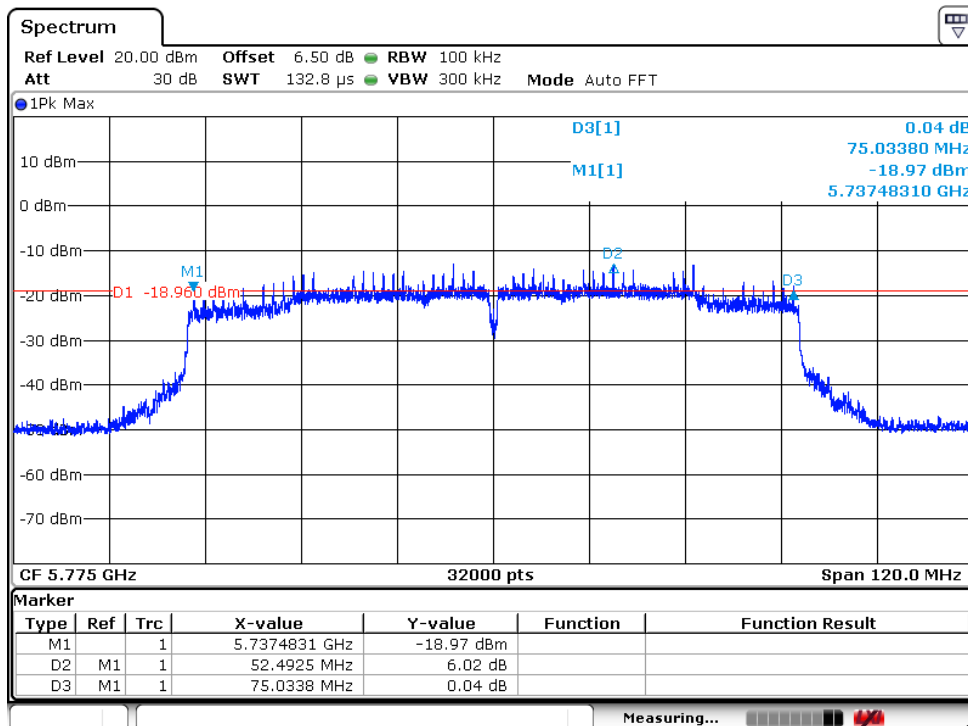

99% OBW 802.11a Channel: 36

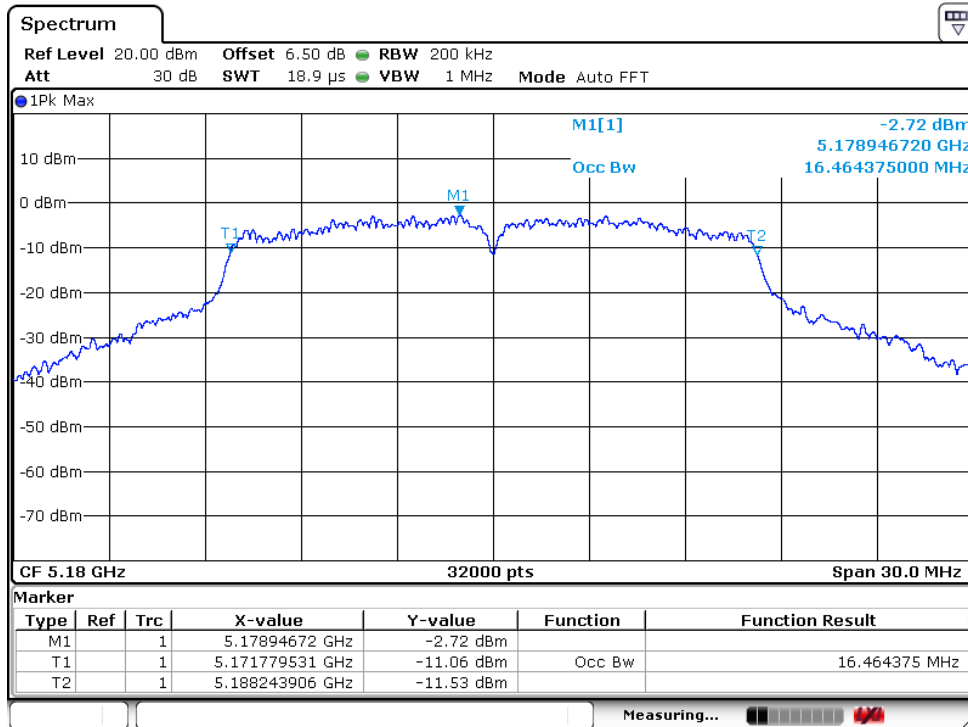

Channel: 40

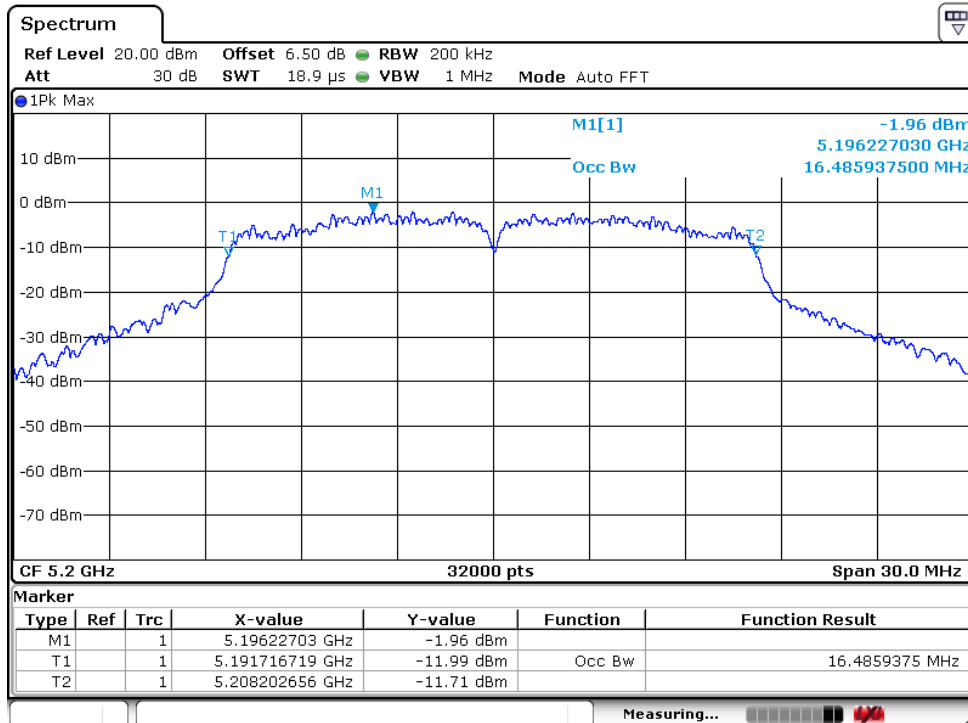

Channel: 48

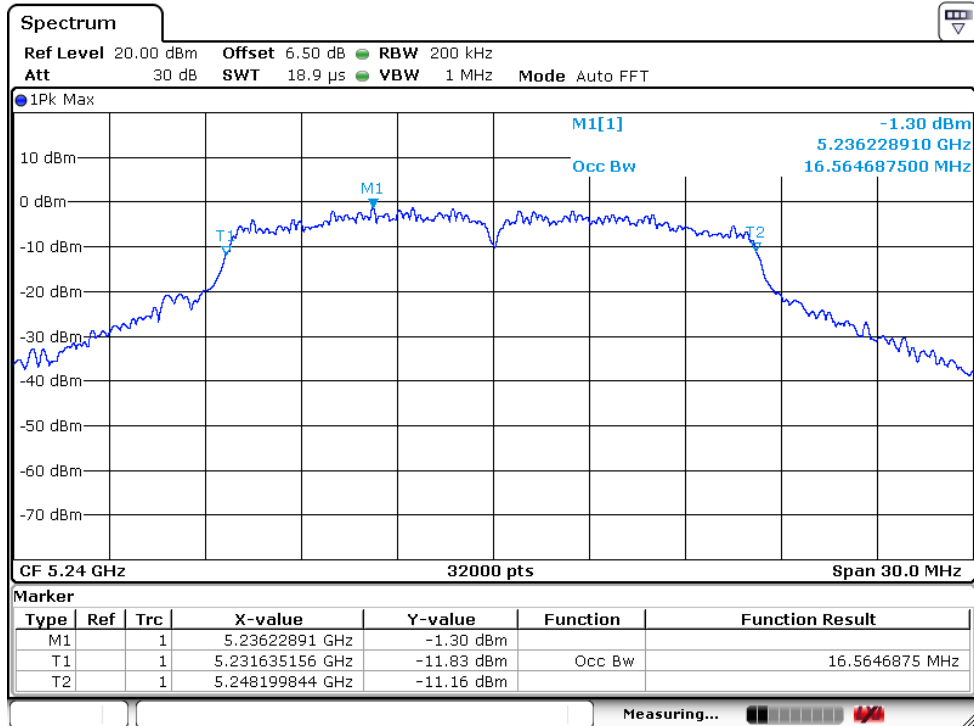

99% OBW 802.11n20 Channel: 36

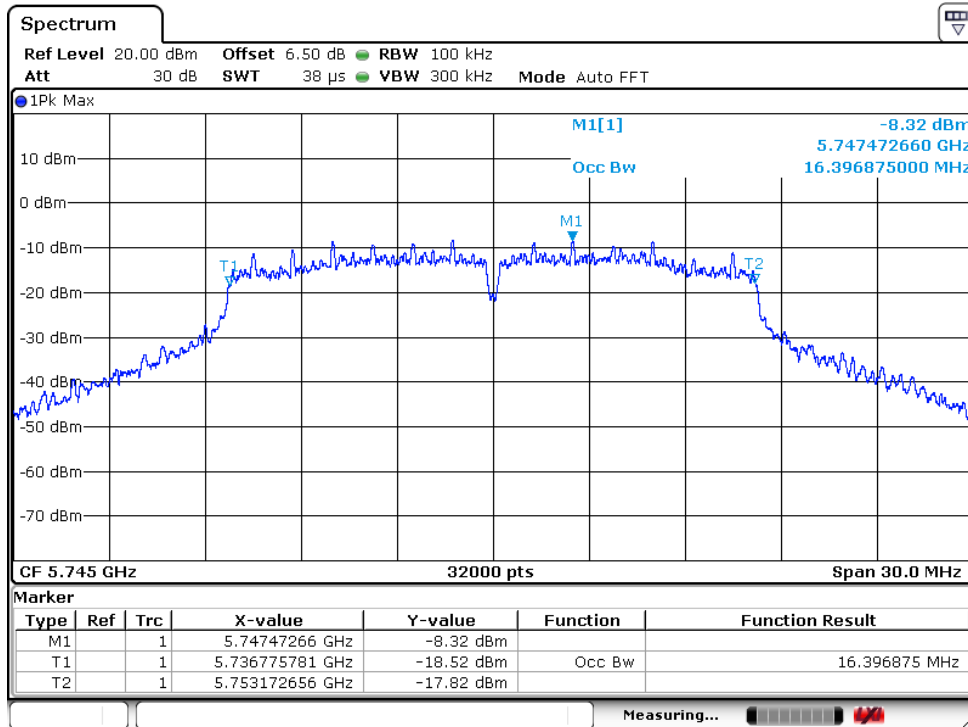

Channel: 40

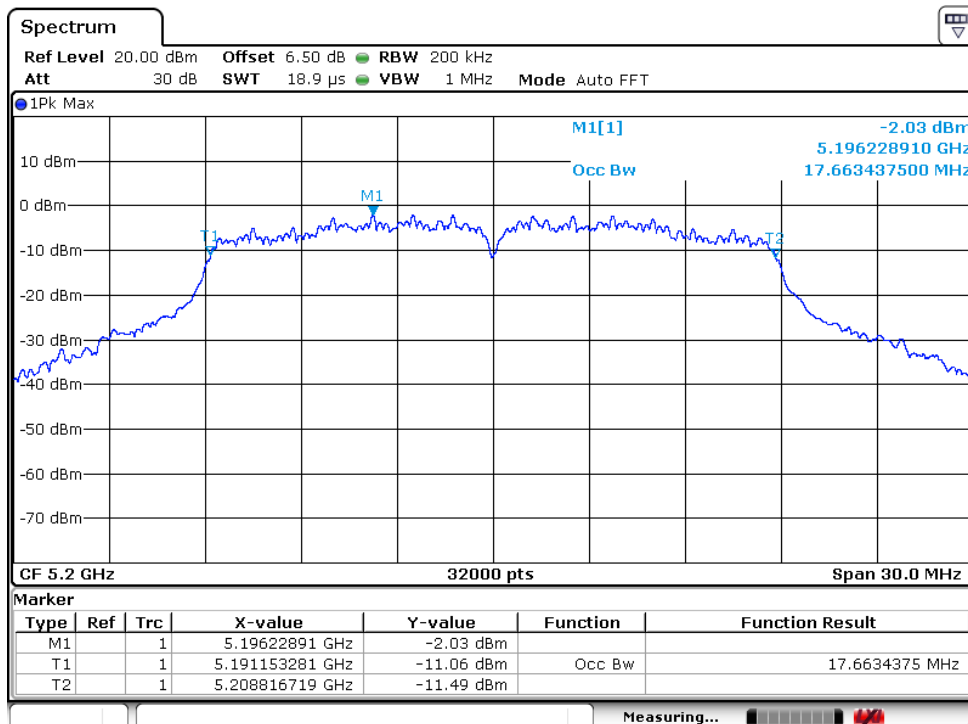

Channel: 48

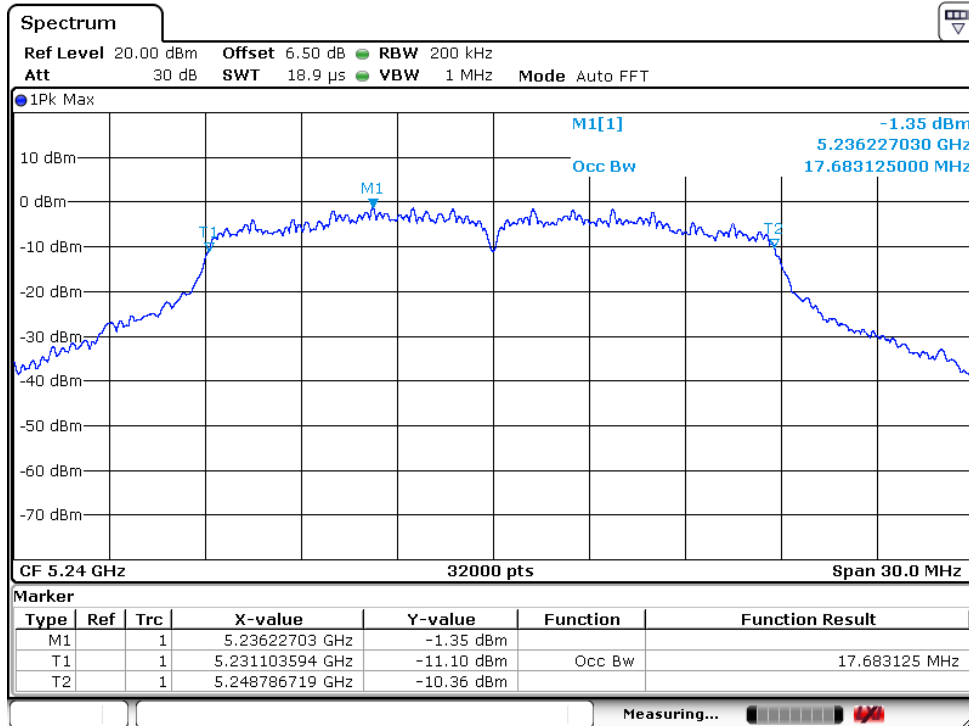

99% OBW 802.11ac20 Channel: 36

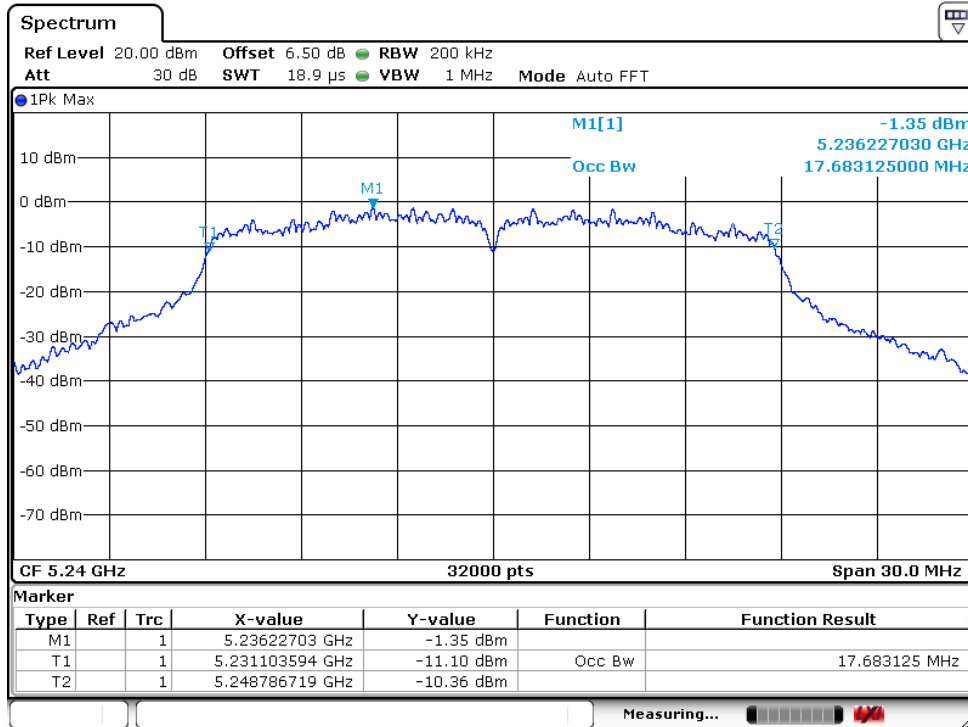

Channel: 40

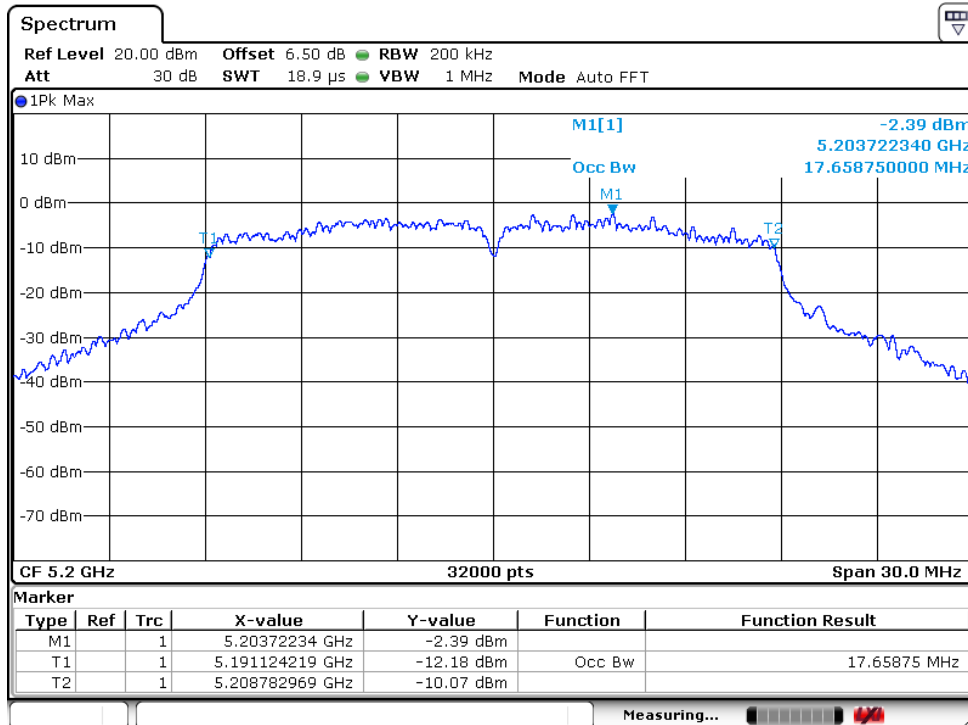

Channel: 48

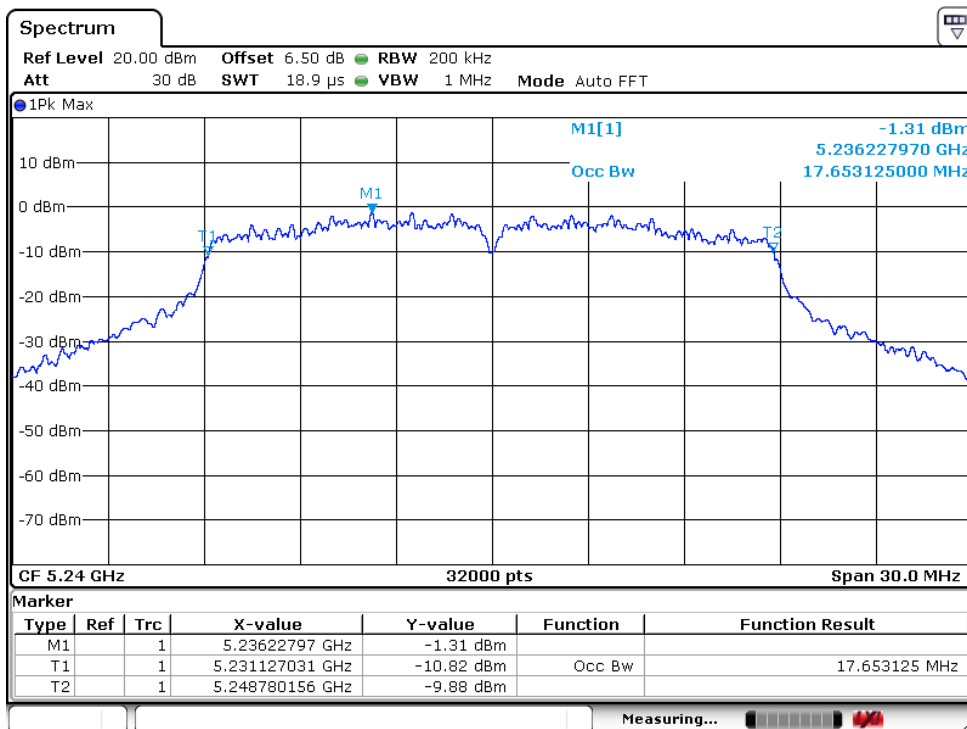

99% OBW 802.11a Channel: 149

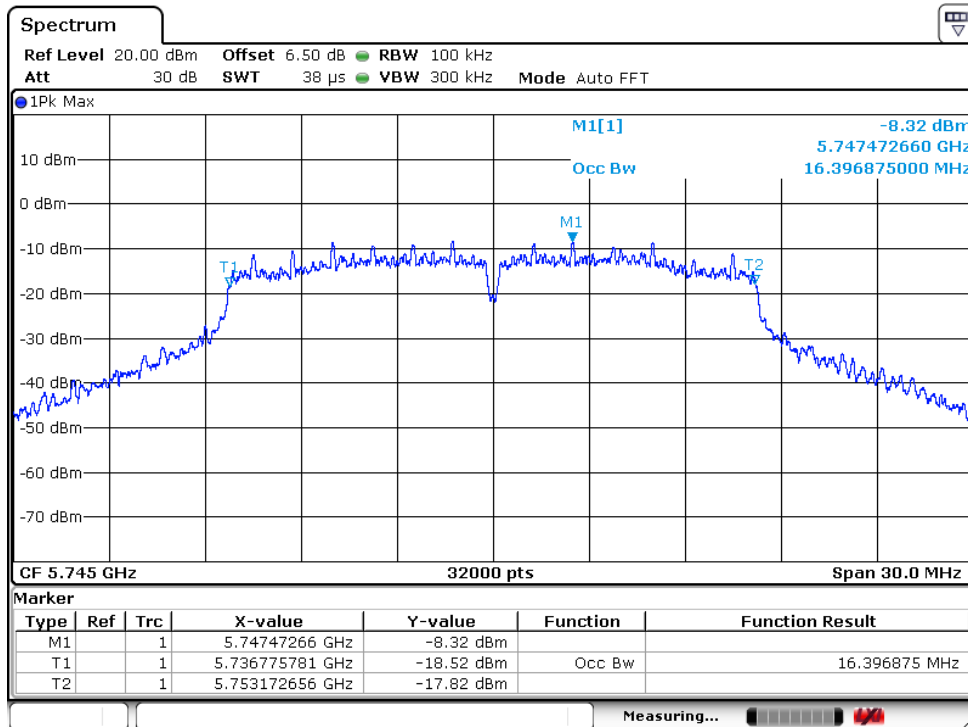

Channel: 157

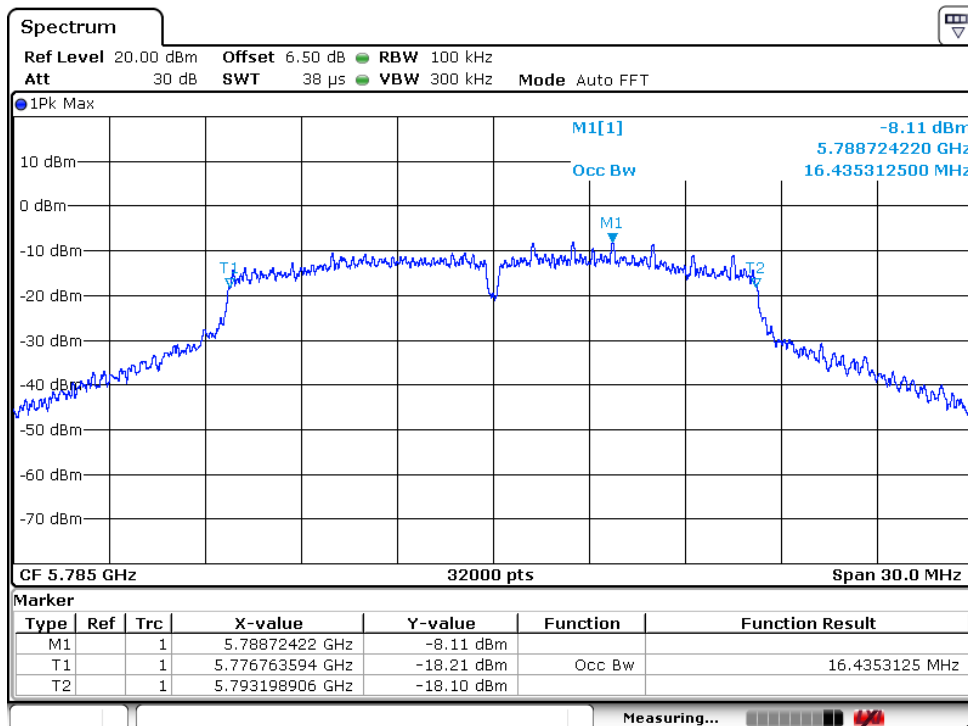

Channel: 165

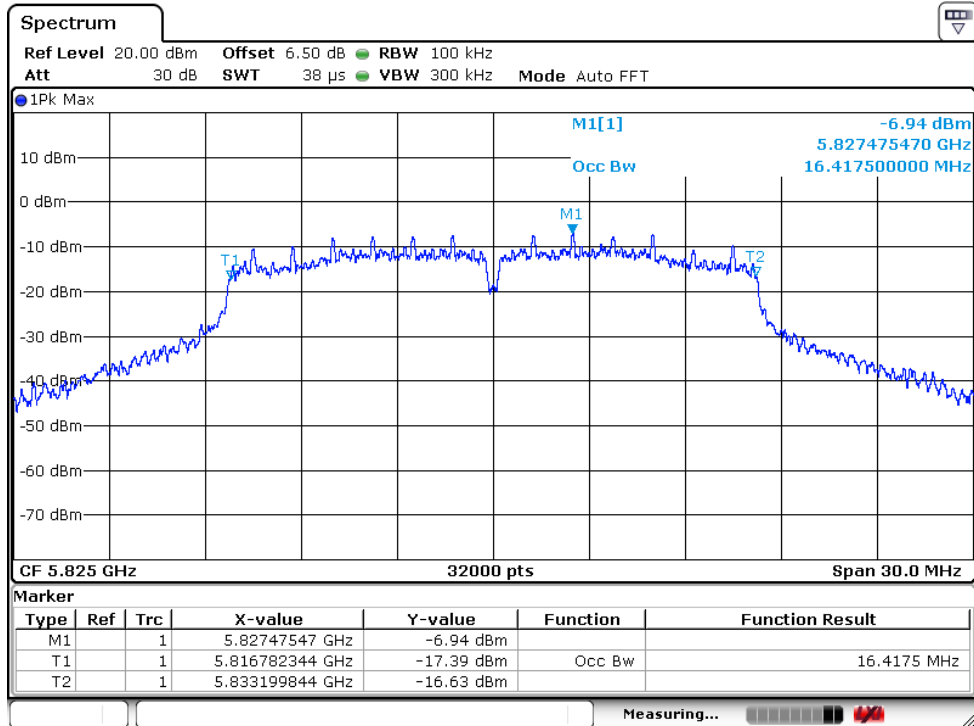

99% OBW 802.11n20 Channel: 149

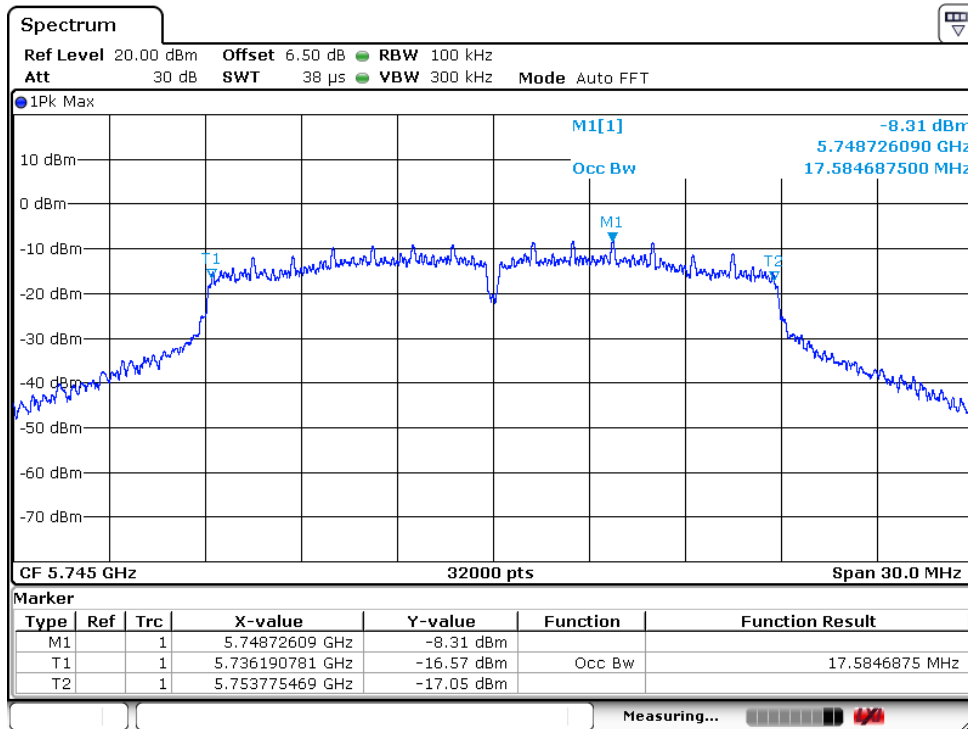

Channel: 157

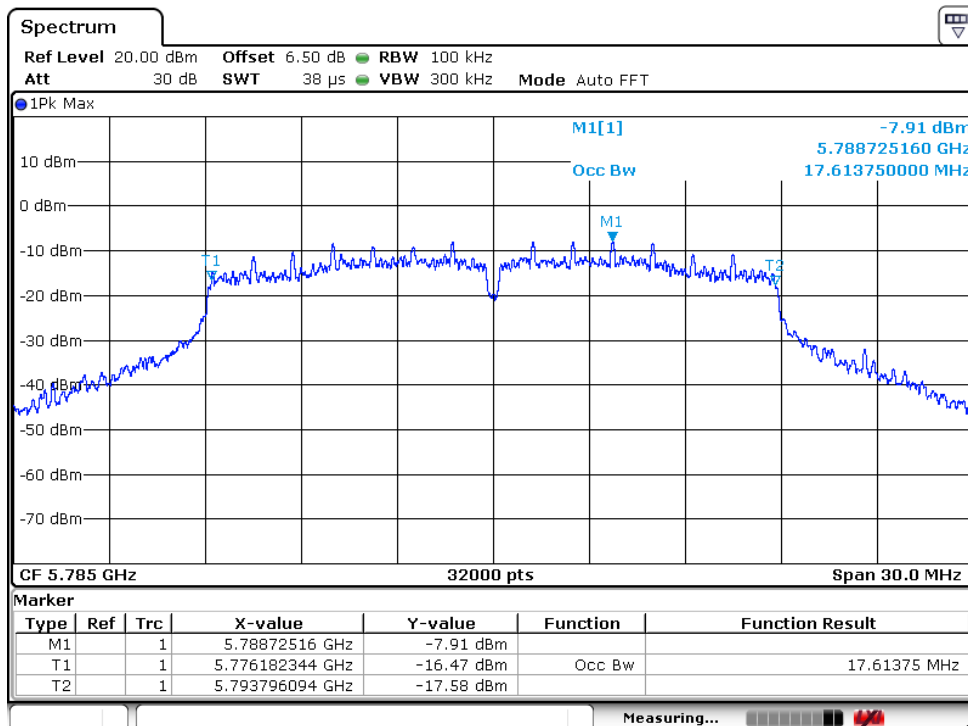

Channel: 165

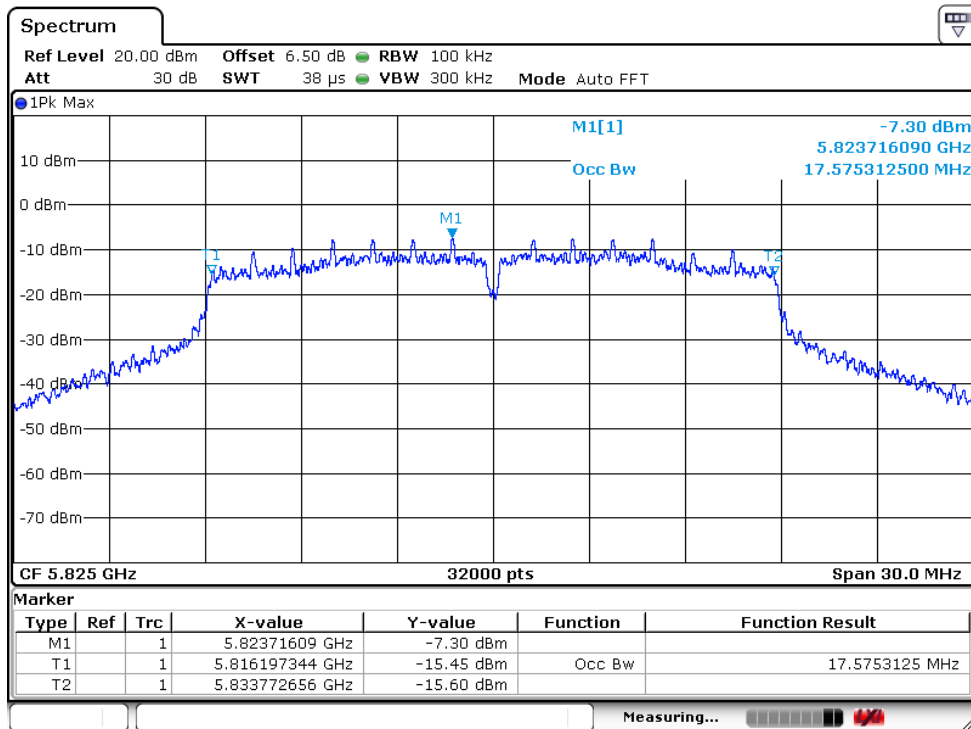

99% OBW 802.11ac20 Channel: 149

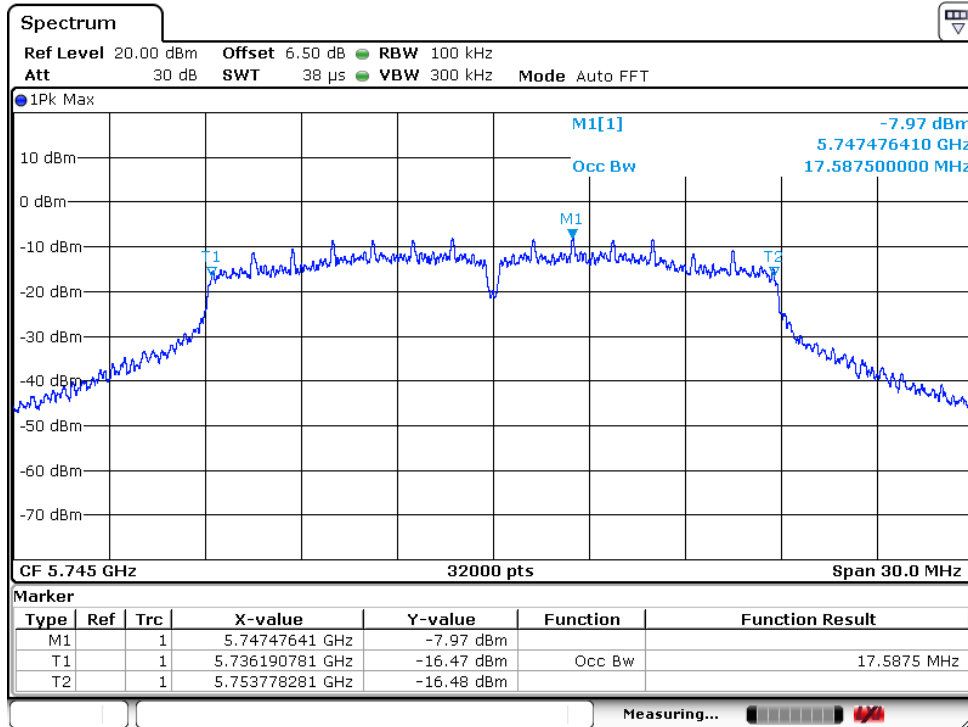

Channel: 157

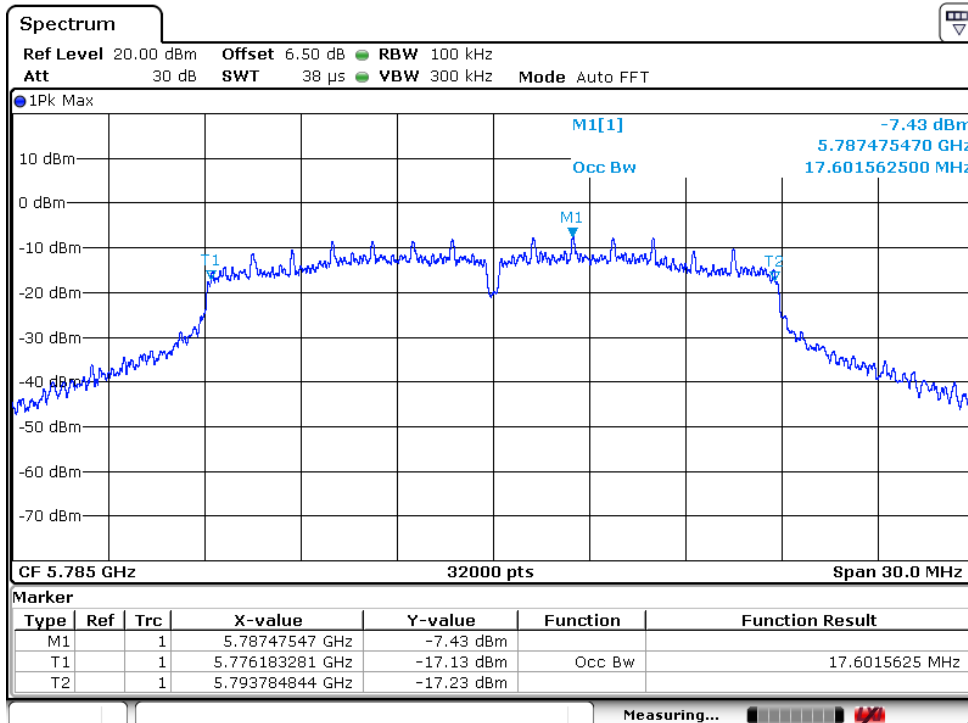

Channel: 165

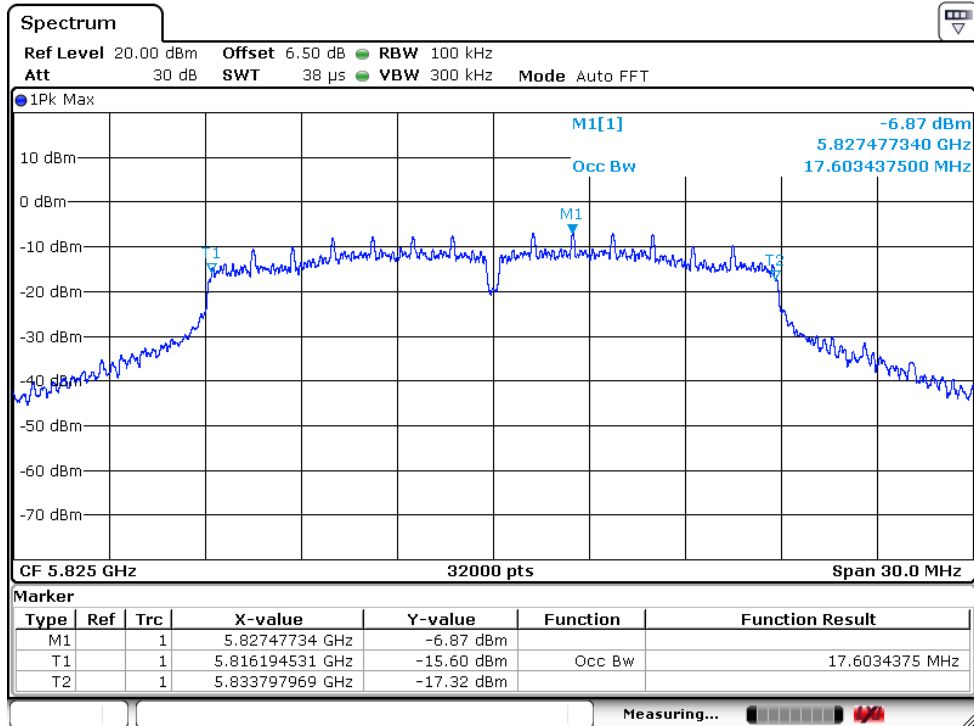

99% OBW 802.11n40 Channel: 38

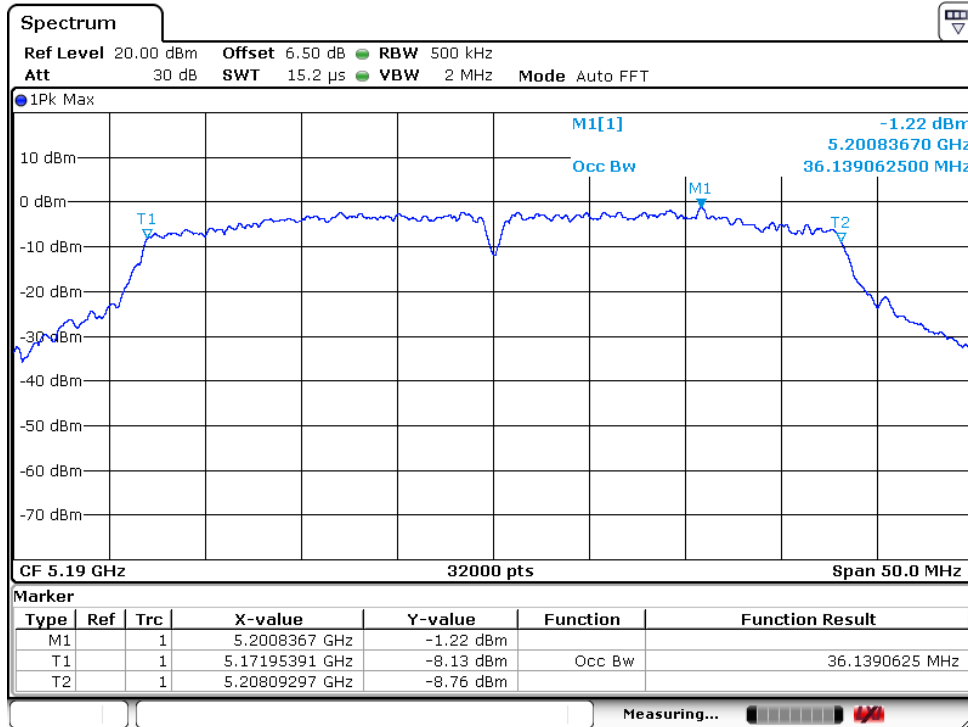

Channel: 46

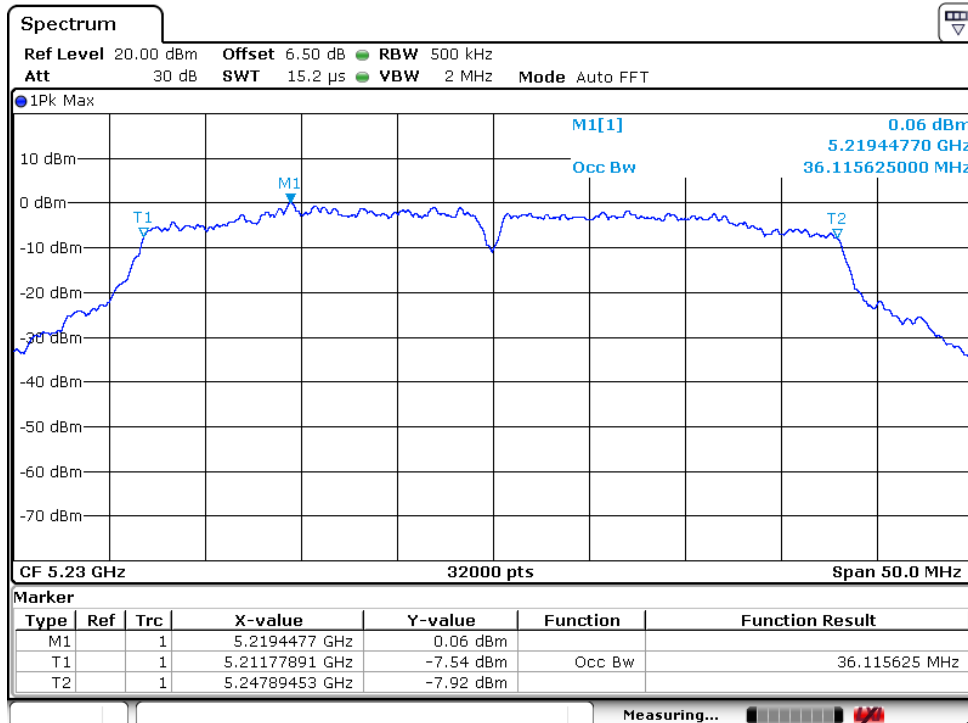

99% OBW 802.11ac40 Channel: 38

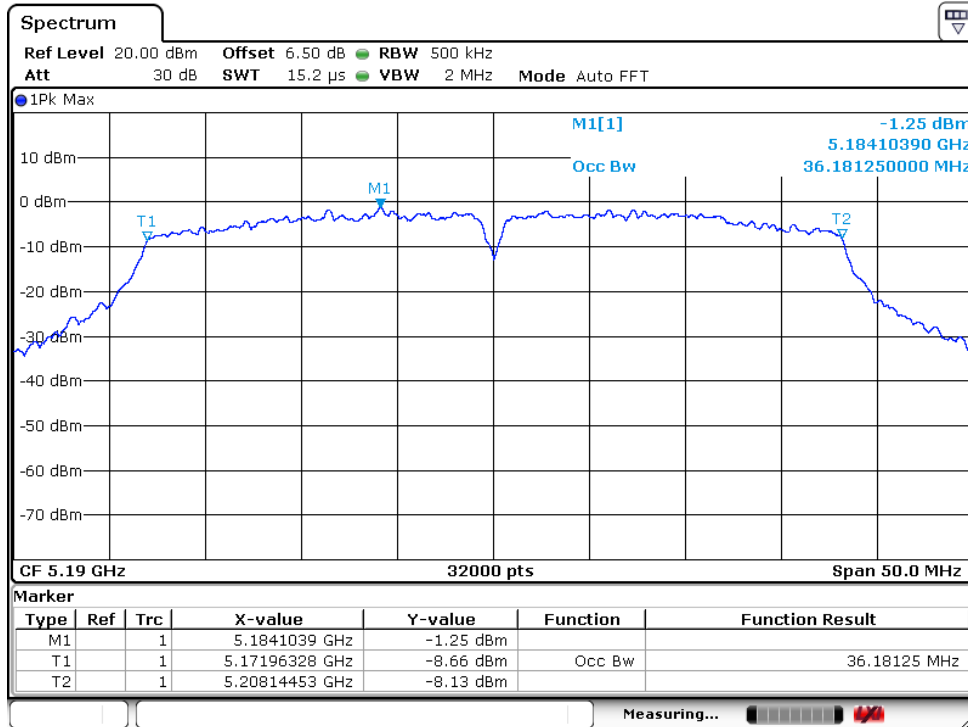

Channel: 46

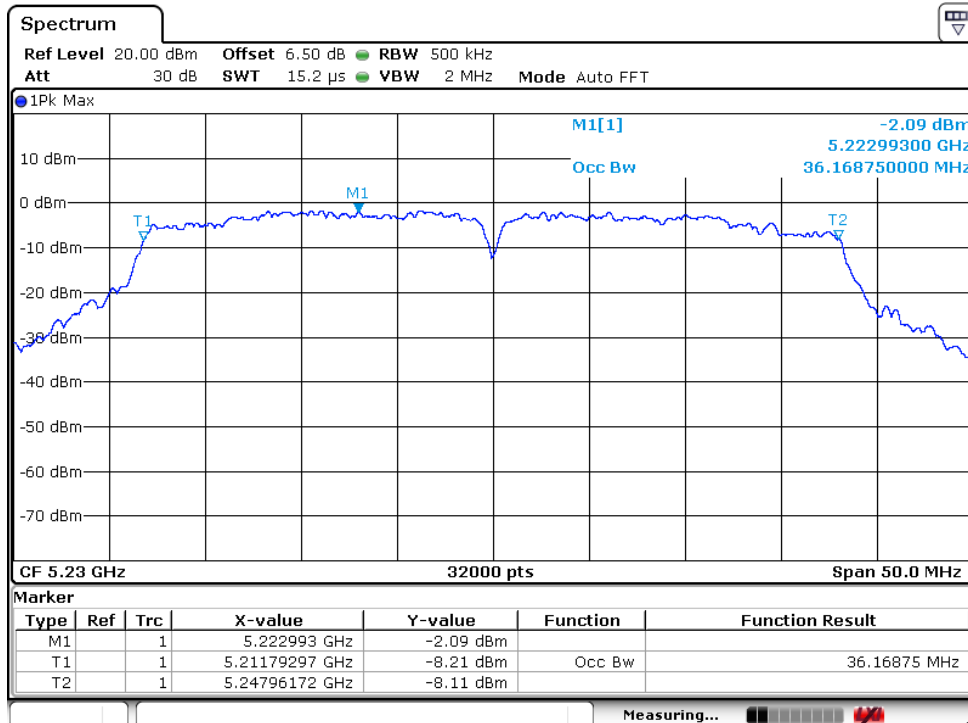

99% OBW 802.11n40 Channel: 151

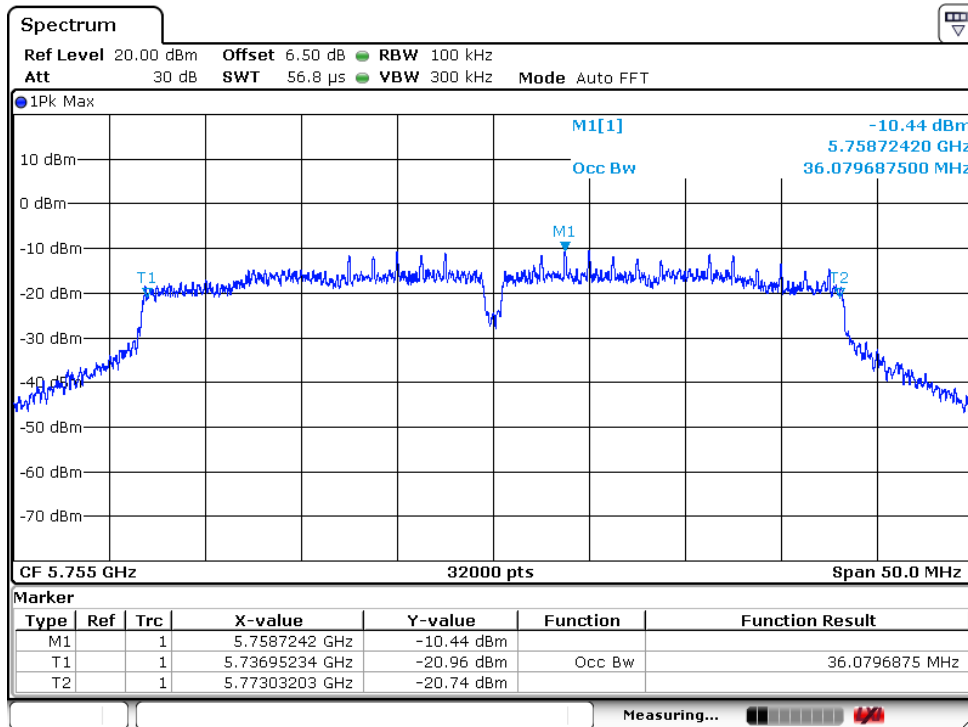

Channel: 159

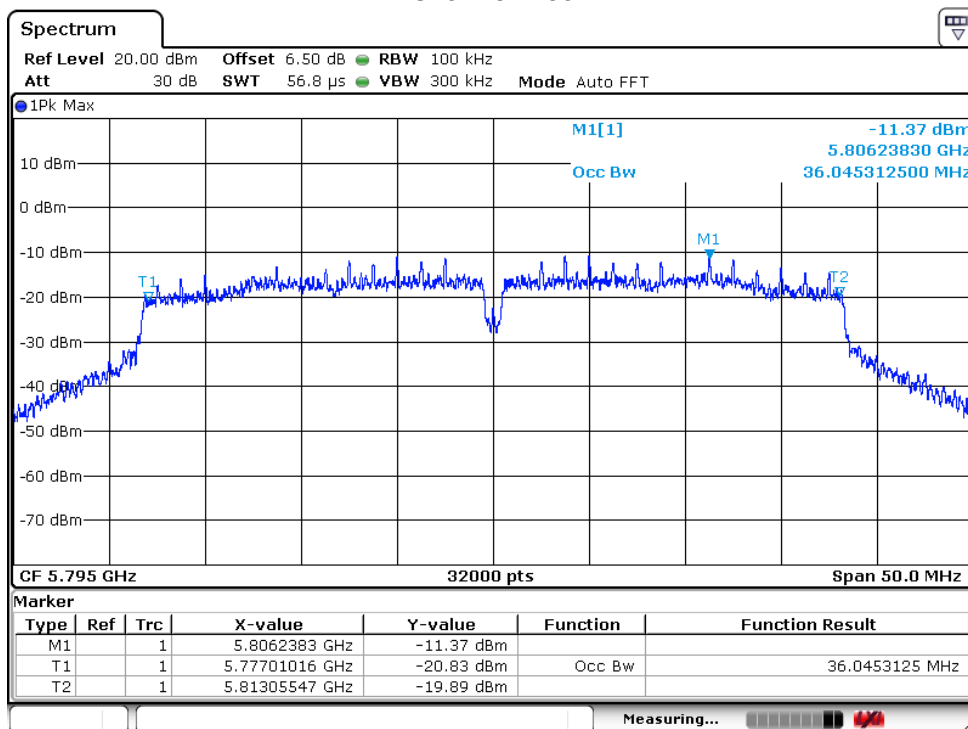

99% OBW 802.11ac40 Channel: 151

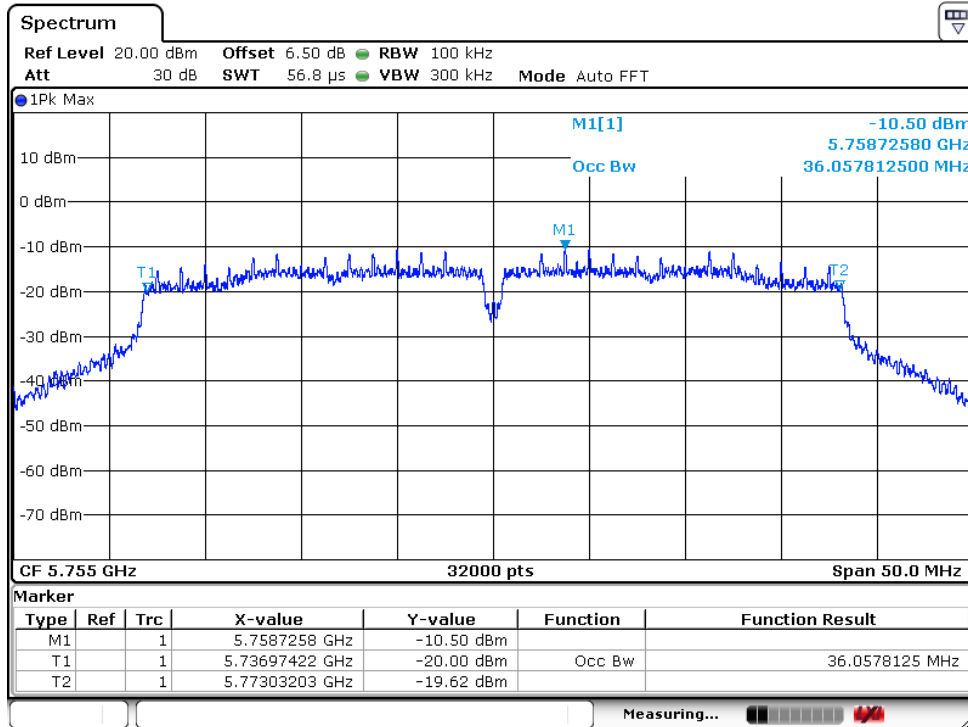

Channel: 159

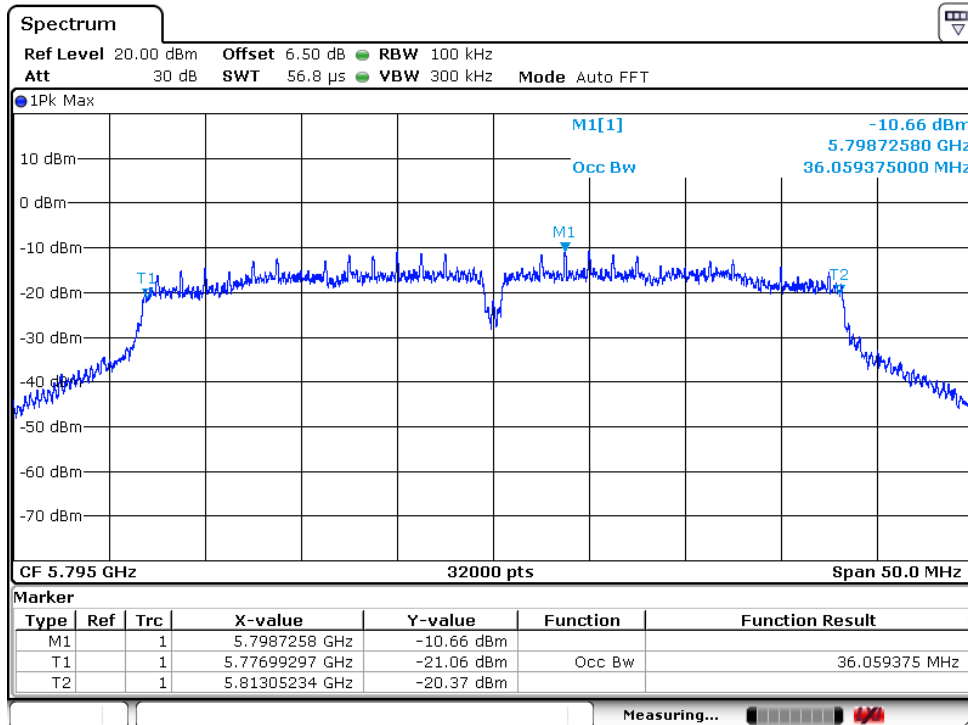

99% OBW 802.11ac80 Channel:42

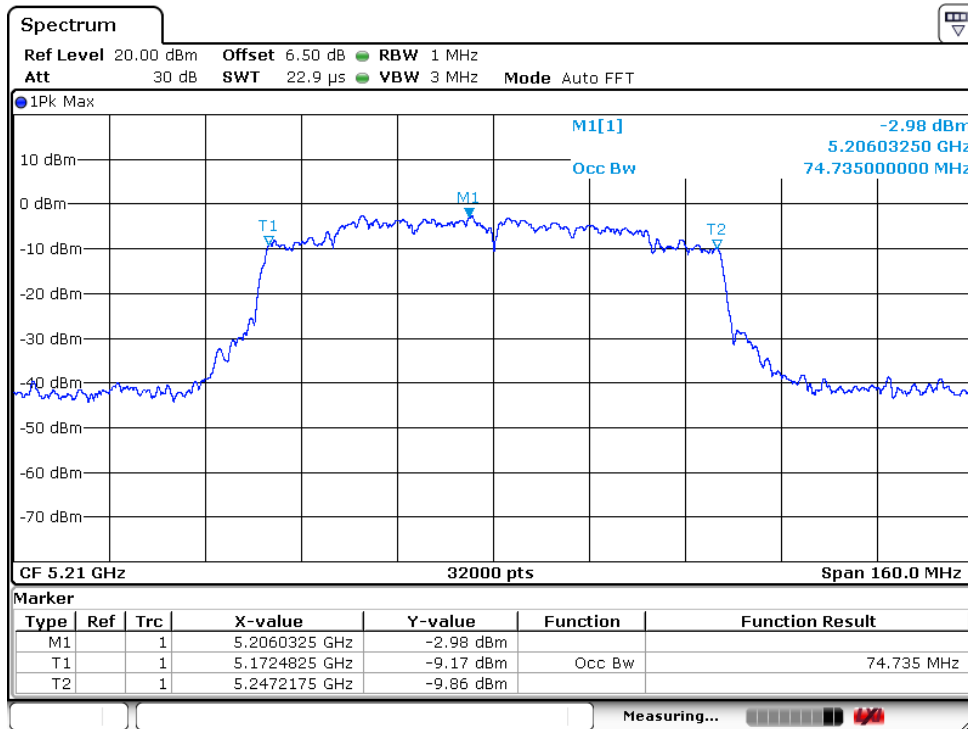

Channel: 155

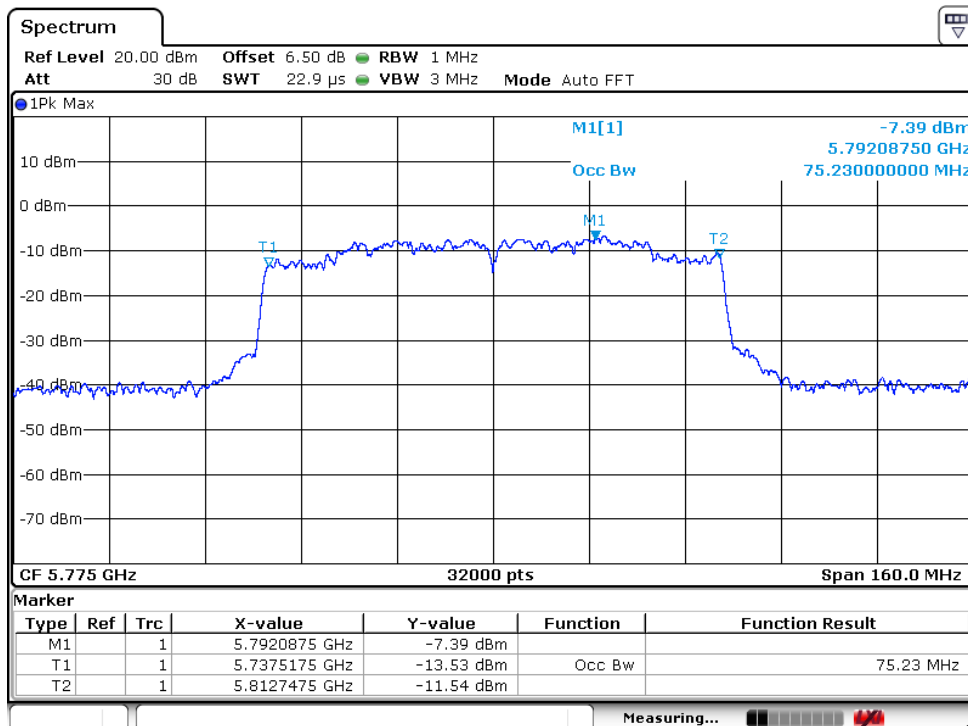

5. MAXIMUM CONDUCTED OUTPUT POWER

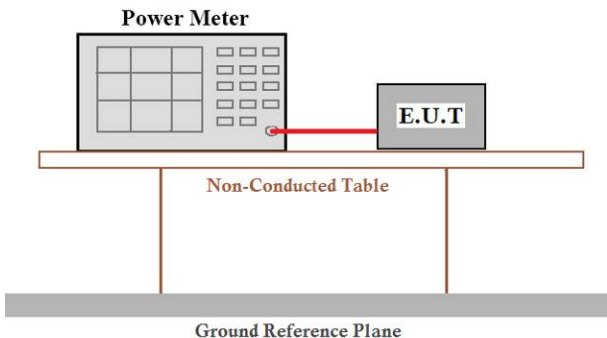
Test Requirement:	FCC Part15 E Section 15.407
Test Method:	KDB 789033 D02 General UNII Test Procedures New Rules v02r01
Limit:	For the band 5.15-5.25 GHz, the maximum conducted output power over the frequency bands of operation shall not exceed 250mW. For the band 5.745-5.850 GHz, the maximum conducted output power over the frequency bands of operation shall not exceed 30dBm
Test setup:	 <p style="text-align: center;">Power Meter</p> <p style="text-align: center;">E.U.T</p> <p style="text-align: center;">Non-Conducted Table</p> <p style="text-align: center;">Ground Reference Plane</p>
Test procedure:	<p style="text-align: center;">Measurement using an RF average power meter</p> <p>(i) Measurements may be performed using a wideband RF power meter with a thermocouple detector or equivalent if all of the conditions listed below are satisfied</p> <p>a) The EUT is configured to transmit continuously or to transmit with a constant duty cycle.</p> <p>b) At all times when the EUT is transmitting, it must be transmitting at its maximum power control level.</p> <p>c) The integration period of the power meter exceeds the repetition period of the transmitted signal by at least a factor of five.</p> <p>(ii) If the transmitter does not transmit continuously, measure the duty cycle, x, of the transmitter output signal as described in section B).</p> <p>(iii) Measure the average power of the transmitter. This measurement is an average over both the on and off periods of the transmitter.</p> <p>(iv) Adjust the measurement in dBm by adding $10 \log(1/x)$ where x is the duty cycle (e.g., $10\log(1/0.25)$ if the duty cycle is 25 percent).</p>
Test Instruments:	Refer to section 5.10 for details
Test mode:	Refer to section 5.3 for details

5.1. TEST RESULT

Antenna A:

CH. No.	Frequency (MHz)	Output Power (dBm)			Limit(dBm)	Result
		802.11a	802.11n (HT20)	802.11ac (VHT20)		
36	5180.00	7.26	6.70	6.91	24	Pass
40	5200.00	7.46	6.72	6.75	24	Pass
48	5240.00	7.03	6.69	6.77	24	Pass
149	5745.00	6.71	6.96	6.74	30	Pass
157	5785.00	6.82	6.90	6.82	30	Pass
165	5825.00	7.02	6.86	6.84	30	Pass

CH. No.	Frequency (MHz)	Output Power (dBm)		Limit(dBm)	Result
		802.11n(HT40)	802.11ac(VHT40)		
38	5190.00	5.92	5.75	24	Pass
46	5230.00	5.64	5.32	24	Pass
151	5755.00	5.50	5.71	30	Pass
159	5795.00	5.70	5.36	30	Pass

CH. No.	Frequency (MHz)	Output Power (dBm)	Limit(dBm)	Result
		802.11ac(VHT80)		
42	5210	7.02	24	Pass
155	5775	6.98	30	Pass

Antenna B:

CH. No.	Frequency (MHz)	Output Power (dBm)			Limit(dBm)	Result
		802.11a	802.11n (HT20)	802.11ac (VHT20)		
36	5180.00	7.04	6.54	6.45	24	Pass
40	5200.00	7.22	6.39	6.63	24	Pass
48	5240.00	6.93	6.47	6.55	24	Pass
149	5745.00	6.41	6.52	6.48	30	Pass
157	5785.00	6.65	6.65	6.72	30	Pass
165	5825.00	7.07	6.73	6.66	30	Pass

CH. No.	Frequency (MHz)	Output Power (dBm)		Limit(dBm)	Result
		802.11n(HT40)	802.11ac(VHT40)		
38	5190.00	5.28	5.44	24	Pass
46	5230.00	5.41	5.10	24	Pass
151	5755.00	5.14	5.26	30	Pass
159	5795.00	5.33	5.32	30	Pass

CH. No.	Frequency (MHz)	Output Power (dBm)	Limit(dBm)	Result
		802.11ac(VHT80)		
42	5210	6.74	24	Pass
155	5775	6.29	30	Pass

6. Band Edges Measurement

Test Requirement:	FCC Part15 E Section 15.407 and 5.205																							
Test Method:	ANSI C63.10:2013																							
Test site:	Measurement Distance: 3m																							
Receiver setup:	<table border="1"> <thead> <tr> <th>Frequency</th> <th>Detector</th> <th>RBW</th> <th>VBW</th> <th>Remark</th> </tr> </thead> <tbody> <tr> <td>30MHz-1GHz</td> <td>Quasi-peak</td> <td>100KHz</td> <td>300KHz</td> <td>Quasi-peak Value</td> </tr> <tr> <td rowspan="2">Above 1GHz</td> <td>Peak</td> <td>1MHz</td> <td>3MHz</td> <td>Peak Value</td> </tr> <tr> <td>AV</td> <td>1MHz</td> <td>3MHz</td> <td>Average Value</td> </tr> </tbody> </table>				Frequency	Detector	RBW	VBW	Remark	30MHz-1GHz	Quasi-peak	100KHz	300KHz	Quasi-peak Value	Above 1GHz	Peak	1MHz	3MHz	Peak Value	AV	1MHz	3MHz	Average Value	
Frequency	Detector	RBW	VBW	Remark																				
30MHz-1GHz	Quasi-peak	100KHz	300KHz	Quasi-peak Value																				
Above 1GHz	Peak	1MHz	3MHz	Peak Value																				
	AV	1MHz	3MHz	Average Value																				
Limit:	<table border="1"> <thead> <tr> <th>Frequency</th> <th>Limit (dBuV/m @3m)</th> <th>Remark</th> </tr> </thead> <tbody> <tr> <td>30MHz-88MHz</td> <td>40.0</td> <td>Quasi-peak Value</td> </tr> <tr> <td>88MHz-216MHz</td> <td>43.5</td> <td>Quasi-peak Value</td> </tr> <tr> <td>216MHz-960MHz</td> <td>46.0</td> <td>Quasi-peak Value</td> </tr> <tr> <td>960MHz-1GHz</td> <td>54.0</td> <td>Quasi-peak Value</td> </tr> <tr> <td rowspan="2">Above 1GHz</td> <td>54.0</td> <td>Average Value</td> </tr> <tr> <td>74.0</td> <td>Peak Value</td> </tr> </tbody> </table> <p>Undesirable emission limits:</p> <ol style="list-style-type: none"> (1) For transmitters operating in the 5.15-5.25 GHz band: all emissions outside of the 5.15-5.35 GHz band shall not exceed an EIRP of -27 dBm/MHz. (2) For transmitters operating in the 5.25-5.35 GHz band: all emissions outside of the 5.15-5.35 GHz band shall not exceed an EIRP of -27 dBm/MHz. Devices operating in the 5.25-5.35 GHz band that generate emissions in the 5.15-5.25 GHz band must meet all applicable technical requirements for operation in the 5.15-5.25 GHz band (including indoor use) or alternatively meet an out-of-band emission EIRP limit of -27 dBm/MHz in the 5.15-5.25 GHz band. (3) For transmitters operating in the 5.47-5.725 GHz band: all emissions outside of the 5.47-5.725 GHz band shall not exceed an EIRP of -27 dBm/MHz. 				Frequency	Limit (dBuV/m @3m)	Remark	30MHz-88MHz	40.0	Quasi-peak Value	88MHz-216MHz	43.5	Quasi-peak Value	216MHz-960MHz	46.0	Quasi-peak Value	960MHz-1GHz	54.0	Quasi-peak Value	Above 1GHz	54.0	Average Value	74.0	Peak Value
Frequency	Limit (dBuV/m @3m)	Remark																						
30MHz-88MHz	40.0	Quasi-peak Value																						
88MHz-216MHz	43.5	Quasi-peak Value																						
216MHz-960MHz	46.0	Quasi-peak Value																						
960MHz-1GHz	54.0	Quasi-peak Value																						
Above 1GHz	54.0	Average Value																						
	74.0	Peak Value																						
Test Procedure:	<ol style="list-style-type: none"> a. The EUT was placed on the top of a rotating table 1.5 m above the ground at a 3 meter camber. The table was rotated 360 degrees to determine the position of the highest radiation. b. The EUT was set 3 meters away from the interference-receiving antenna, which was mounted on the top of a variable-height antenna tower. c. The antenna height is varied from one meter to four meters above the ground to determine the maximum value of the field strength. Both horizontal and vertical polarizations of the antenna are set to make the measurement. d. For each suspected emission, the EUT was arranged to its worst case and then the antenna was tuned to heights from 1 meter to 4 meters and the rotatable table was turned from 0 degrees to 360 degrees to find the maximum reading. e. The test-receiver system was set to Peak Detect Function and Specified Bandwidth with Maximum Hold Mode. f. If the emission level of the EUT in peak mode was 10dB lower than the limit specified, then testing could be stopped and the peak values of the EUT would be reported. Otherwise the emissions that did not have 10dB margin would be re-tested one by one using peak, quasi-peak or average method as specified and then reported in a 																							

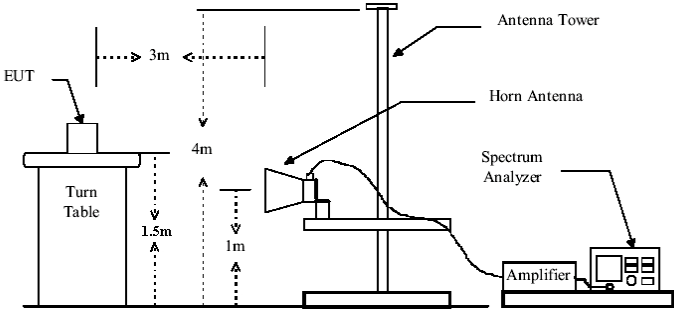
<p>Test setup:</p>	<p>data sheet.</p> <p style="text-align: center;">Above 1GHz</p> 
<p>Test Instruments:</p>	<p>Refer to section 5.10 for details</p>
<p>Test mode:</p>	<p>Refer to section 5.3 for details</p>
<p>Test results:</p>	<p>Pass</p>

Remark:

According to KDB 789033 v02r01 section G) 1) (d), for For measurements above 1000 MHz @ 3m distance the limit of field strength is computed as follows:

$$E[\text{dBuV/m}] = \text{EIRP}[\text{dBm}] + 95.2;$$

For example, if EIRP = -27dBm

$$E[\text{dBuV/m}] = -27 + 95.2 = 68.2\text{dBuV/m}.$$

6.1. TEST RESULT

Peak value:

Test mode:		802.11a		Test channel:		Lowest	
Frequency (MHz)	Reading Level (dBuV)	Factor (dB/m)	Measure Level (dBuV/m)	Limit (dBuV/m)	Over limit(dB)	Detector	Antenna Pol.
5150	44.28	7.18	51.46	68.2	-16.74	PK	H
5150	43.18	7.18	50.36	68.2	-17.84	PK	V
Test mode:		802.11a		Test channel:		Highest	
Frequency (MHz)	Reading Level (dBuV)	Factor (dB/m)	Measure Level (dBuV/m)	Limit (dBuV/m)	Over limit(dB)	Detector	Antenna Pol.
5350	43.38	7.2	50.58	68.2	-17.62	PK	H
5350	49.17	7.2	56.37	68.2	-11.83	PK	V

Peak value:

Test mode:		802.11n(HT20)		Test channel:		Lowest	
Frequency (MHz)	Reading Level (dBuV)	Factor (dB/m)	Measure Level (dBuV/m)	Limit (dBuV/m)	Over limit(dB)	Detector	Antenna Pol.
5150	47.47	7.18	54.65	68.2	-13.55	PK	H
5150	54.08	7.18	61.26	68.2	-6.94	PK	V
Test mode:		802.11n(HT20)		Test channel:		Highest	
Frequency (MHz)	Reading Level (dBuV)	Factor (dB/m)	Measure Level (dBuV/m)	Limit (dBuV/m)	Over limit(dB)	Detector	Antenna Pol.
5350	43.14	7.2	50.34	68.2	-17.86	PK	H
5350	50.05	7.2	57.25	68.2	-10.95	PK	V

Peak value:

Test mode:		802.11n(HT40)		Test channel:		Lowest	
Frequency (MHz)	Reading Level	Factor	Measure Level	Limit (dBuV/m)	Margin (dB)	Detector	Antenna Pol.
5150	42.78	7.18	49.96	68.2	-18.24	PK	H
5150	43.07	7.18	50.25	68.2	-17.95	PK	V
Test mode:		802.11n(HT40)		Test channel:		Highest	
Frequency (MHz)	Reading Level	Factor	Measure Level	Limit (dBuV/m)	Margin (dB)	Detector	Antenna Pol.
5350	43.96	7.2	51.16	68.2	-17.04	PK	H
5350	47.09	7.2	54.29	68.2	-13.91	PK	V

Peak value:

Test mode:		802.11ac(VHT80)		Test channel:		Lowest	
Frequency (MHz)	Reading Level	Factor	Measure Level	Limit (dBuV/m)	Margin (dB)	Detector	Antenna Pol.
5150	45.18	7.18	52.36	68.2	-15.84	PK	H
5150	48.39	7.18	55.57	68.2	-12.63	PK	V
Test mode:		802.11ac(VHT80)		Test channel:		Highest	
Frequency (MHz)	Reading Level	Factor	Measure Level	Limit (dBuV/m)	Margin (dB)	Detector	Antenna Pol.
5350	46.03	7.2	53.23	68.2	-14.97	PK	H
5350	48.27	7.2	55.47	68.2	-12.73	PK	V

Test mode: 802.11a Test channel: Lowest

Peak value:

Frequency (MHz)	Read Level (dBuV)	Factor (dB/m)	Level (dBuV/m)	Limit Line (dBuV/m)	Over Limit (dB)	Polarization
5725	39.94	8.79	48.73	74	-25.27	Horizontal
5741.35	82.31	8.57	90.88	N/A	N/A	Horizontal
5725	40.87	8.79	49.66	74	-24.34	Vertical
5741.35	84.36	8.57	92.93	N/A	N/A	Vertical

Average

Frequency (MHz)	Read Level (dBuV)	Factor (dB/m)	Level (dBuV/m)	Limit Line (dBuV/m)	Over Limit (dB)	Polarization
5725	30.04	8.79	38.83	54	-15.17	Horizontal
5741.35	72.14	8.57	80.71	N/A	N/A	Horizontal
5725	30.22	8.79	39.01	54	-14.99	Vertical
5741.35	74.98	8.57	83.55	N/A	N/A	Vertical

Test mode: 802.11a Test channel: Highest

Frequency (MHz)	Read Level (dBuV)	Factor (dB/m)	Level (dBuV/m)	Limit Line (dBuV/m)	Over Limit (dB)	Polarization
5826.2	78.44	8.79	87.23	N/A	N/A	Horizontal
5850	38.02	8.82	46.84	74	-27.16	Horizontal
5826.2	85.17	8.79	93.96	N/A	N/A	Vertical
5850	39.96	8.82	48.78	74	-25.22	Vertical

Average

Frequency (MHz)	Read Level (dBuV)	Factor (dB/m)	Level (dBuV/m)	Limit Line (dBuV/m)	Over Limit (dB)	Polarization
5826.2	69.97	8.79	78.76	N/A	N/A	Horizontal
5850	28.14	8.82	36.96	54	-17.04	Horizontal
5826.2	76.01	8.79	84.8	N/A	N/A	Vertical
5850	28.37	8.82	37.19	54	-16.81	Vertical

Test mode: 802.11n(HT20) Test channel: Lowest

Peak value:

Frequency (MHz)	Read Level (dBuV)	Factor (dB/m)	Level (dBuV/m)	Limit Line (dBuV/m)	Over Limit (dB)	Polarization
5725	37.41	8.79	46.2	74	-27.8	Horizontal
5742.19	77.09	8.57	85.66	N/A	N/A	Horizontal
5725	39.78	8.79	48.57	74	-25.43	Vertical
5742.19	84.04	8.57	92.61	N/A	N/A	Vertical

Average

Frequency (MHz)	Read Level (dBuV)	Factor (dB/m)	Level (dBuV/m)	Limit Line (dBuV/m)	Over Limit (dB)	Polarization
5725	28.14	8.79	36.93	54	-17.07	Horizontal
5742.19	68.33	8.57	76.9	N/A	N/A	Horizontal
5725	29.17	8.79	37.96	54	-16.04	Vertical
5742.19	75.35	8.57	83.92	N/A	N/A	Vertical

Test mode: 802.11n(HT20) Test channel: Highest

Peak value:

Frequency (MHz)	Read Level (dBuV)	Factor (dB/m)	Level (dBuV/m)	Limit Line (dBuV/m)	Over Limit (dB)	Polarization
5826.2	77.11	8.79	85.9	N/A	N/A	Horizontal
5850	38.02	8.82	46.84	74	-27.16	Horizontal
5826.2	85.57	8.79	94.36	N/A	N/A	Vertical
5850	40.19	8.82	49.01	74	-24.99	Vertical

Average

Frequency (MHz)	Read Level (dBuV)	Factor (dB/m)	Level (dBuV/m)	Limit Line (dBuV/m)	Over Limit (dB)	Polarization
5826.2	68.24	8.79	77.03	N/A	N/A	Horizontal
5850	28.02	8.82	36.84	54	-17.16	Horizontal
5826.2	74.16	8.79	82.95	N/A	N/A	Vertical
5850	28.98	8.82	37.8	54	-16.2	Vertical

Test mode: 802.11n(HT40) Test channel: Lowest

Peak value:

Frequency (MHz)	Read Level (dBuV)	Factor (dB/m)	Level (dBuV/m)	Limit Line (dBuV/m)	Over Limit (dB)	Polarization
5725	38.16	8.52	46.68	74	-27.32	Horizontal
5745	74.89	8.57	83.46	N/A	N/A	Horizontal
5725	37.77	8.52	46.29	74	-27.71	Vertical
5745	84.36	8.57	92.93	N/A	N/A	Vertical

Average

Frequency (MHz)	Read Level (dBuV)	Factor (dB/m)	Level (dBuV/m)	Limit Line (dBuV/m)	Over Limit (dB)	Polarization
5725	30.25	8.52	38.77	54	-15.23	Horizontal
5745	68.74	8.57	77.31	N/A	N/A	Horizontal
5725	28.15	8.52	36.67	54	-17.33	Vertical
5745	75.03	8.57	83.6	N/A	N/A	Vertical

Test mode: 802.11n(HT40) Test channel: Highest

Peak value:

Frequency (MHz)	Read Level (dBuV)	Factor (dB/m)	Level (dBuV/m)	Limit Line (dBuV/m)	Over Limit (dB)	Polarization
5784.88	78.52	8.68	87.2	N/A	N/A	Horizontal
5850	38.61	8.82	47.43	74	-26.57	Horizontal
5784.88	84.33	8.68	93.01	N/A	N/A	Vertical
5850	42.42	8.82	51.24	74	-22.76	Vertical

Average

Frequency (MHz)	Read Level (dBuV)	Factor (dB/m)	Level (dBuV/m)	Limit Line (dBuV/m)	Over Limit (dB)	Polarization
5784.88	71.12	8.68	79.8	N/A	N/A	Horizontal
5850	28.06	8.82	36.88	54	-17.12	Horizontal
5784.88	74.31	8.68	82.99	N/A	N/A	Vertical
5850	27.29	8.82	36.11	54	-17.89	Vertical

Test mode: 802.11ac(VHT80) Test channel: Middle

Peak value:

Frequency (MHz)	Read Level (dBuV)	Factor (dB/m)	Level (dBuV/m)	Limit Line (dBuV/m)	Over Limit (dB)	Polarization
5725.000	37.45	8.52	45.97	74.00	-28.03	Horizontal
5778.180	78.36	8.68	87.04	N/A	N/A	Horizontal
5850.000	36.24	8.82	45.06	74.00	-28.94	Horizontal
5725.000	37.52	8.52	46.04	74.00	-27.96	Vertical
5778.180	82.03	8.68	90.71	N/A	N/A	Vertical
5850.000	40.11	8.82	48.93	74.00	-25.07	Vertical

Average

Frequency (MHz)	Read Level (dBuV)	Factor (dB/m)	Level (dBuV/m)	Limit Line (dBuV/m)	Over Limit (dB)	Polarization
5725.000	29.63	8.52	38.15	54.00	-15.85	Horizontal
5778.180	69.71	8.68	78.39	N/A	N/A	Horizontal
5850.000	28.18	8.82	37.00	54.00	-17.00	Horizontal
5725.000	28.58	8.52	37.10	54.00	-16.90	Vertical
5778.180	71.06	8.68	79.74	N/A	N/A	Vertical
5850.000	29.17	8.82	37.99	54.00	-16.01	Vertical

7. RADIATED EMISSION MEASUREMENT

7.1. Test equipment

Item	Equipment	Manufacturer	Model No.	Serial No.	Calibrated until	Calibrated Date
1	EMI Test Receiver	R&S	ESCI	101307	12/17/2018	12/18/2017
2	Spectrum analyzer	Agilent	E4407B	US40240708	07/04/2019	07/05/2018
3	Trilog Broadband Antenna	Schwarzbeck	VULB9168	VULB9168-192	03/04/2019	03/05/2018
4	Double Ridged Horn Antenna	SCHWARZBEC K	BBHA 9120D1065	100276	12/17/2018	12/18/2017
5	Double Ridged Horn Antenna	SCHWARZBEC K	BBHA 9120D1065	100546	12/17/2018	12/18/2017
6	Dipole antenna	Schwarzbeck	UHAP	1101	12/17/2018	12/18/2017
7	Dipole antenna	Schwarzbeck	VHAP	1118	12/17/2018	12/18/2017
8	Pre-Amplifier	CY	EMC011830	980136	12/17/2018	12/18/2017
9	Pre-amplifier	HP	8447F	3113A05680	12/17/2018	12/18/2017
10	RF Cable	R&S	R01	10403	12/17/2018	12/18/2017
11	RF Cable	R&S	R02	10512	12/17/2018	12/18/2017
12	RF Cable	R&S	R01	10454	12/17/2018	12/18/2017
13	RF Cable	R&S	R02	10343	12/17/2018	12/18/2017
14	Spectrum analyze	R&S	FSV40	101470	29/06/2019	06/29/2018
15	Measurement Software	Farad	EZ-EMC (Ver.ATT-03 A)	N/A	N/A	N/A
16	Loop antenna	TESEQ	HLA6120	20129	12/17/2018	12/18/2017

7.2. Block diagram of test setup

In 3m Anechoic Chamber Test Setup Diagram for 9KHz-30MHz

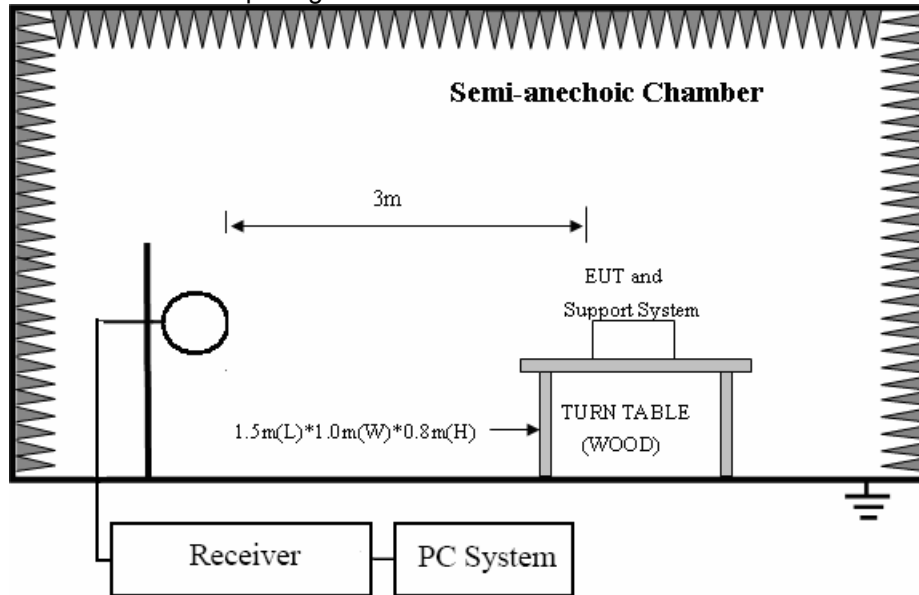

In 3m Anechoic Chamber Test Setup Diagram for 30MHz-1GHz

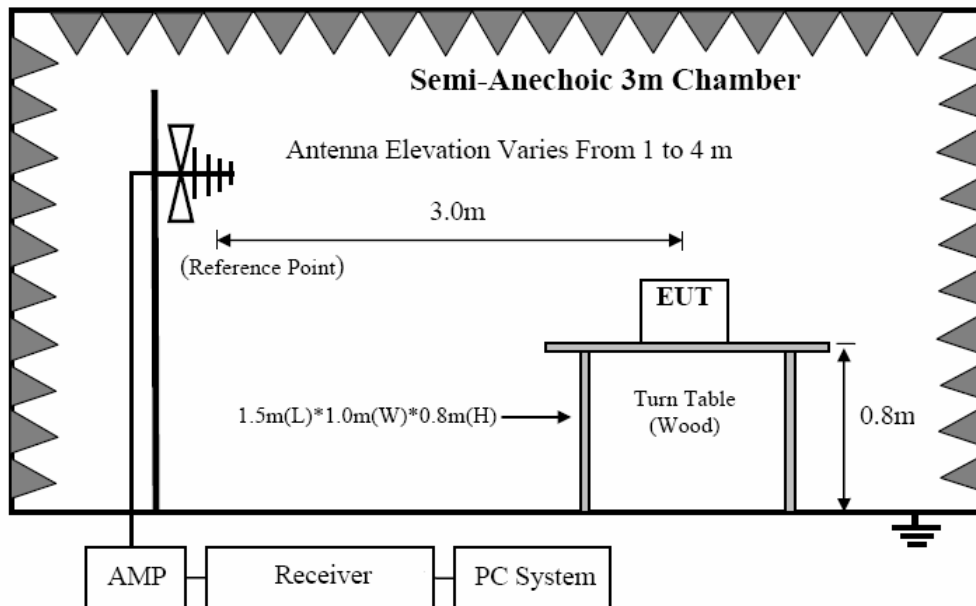

In 3m Anechoic Chamber Test Setup Diagram for frequency above 1GHz

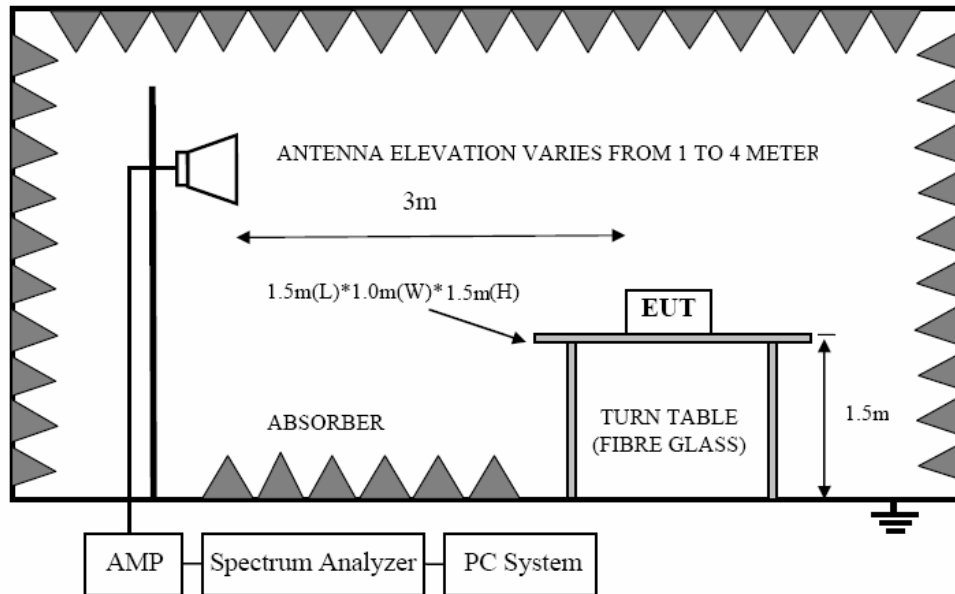

Note: For harmonic emissions test a appropriate high pass filter was inserted in the input port of AMP.

7.3. Limit

9.3.1 FCC 15.205 Restricted frequency band

MHz	MHz	MHz	GHz
0.090 - 0.110	16.42 - 16.423	399.9 - 410	4.5 - 5.15
¹ 0.495 - 0.505	16.69475 - 16.69525	608 - 614	5.35 - 5.46
2.1735 - 2.1905	16.80425 - 16.80475	960 - 1240	7.25 - 7.75
4.125 - 4.128	25.5 - 25.67	1300 - 1427	8.025 - 8.5
4.17725 - 4.17775	37.5 - 38.25	1435 - 1626.5	9.0 - 9.2
4.20725 - 4.20775	73 - 74.6	1645.5 - 1646.5	9.3 - 9.5
6.215 - 6.218	74.8 - 75.2	1660 - 1710	10.6 - 12.7
6.26775 - 6.26825	108 - 121.94	1718.8 - 1722.2	13.25 - 13.4
6.31175 - 6.31225	123 - 138	2200 - 2300	14.47 - 14.5
8.291 - 8.294	149.9 - 150.05	2310 - 2390	15.35 - 16.2
8.362 - 8.366	156.52475 - 156.52525	2483.5 - 2500	17.7 - 21.4
8.37625 - 8.38675	156.7 - 156.9	2690 - 2900	22.01 - 23.12
8.41425 - 8.41475	162.0125 - 167.17	3260 - 3267	23.6 - 24.0
12.29 - 12.293	167.72 - 173.2	3332 - 3339	31.2 - 31.8
12.51975 - 12.52025	240 - 285	3345.8 - 3358	36.43 - 36.5
12.57675 - 12.57725	322 - 335.4	3600 - 4400	(²)

9.3.2. FCC 15.209 Limit.

FREQUENCY MHz	DISTANCE Meters	FIELD STRENGTHS LIMIT	
		$\mu\text{V}/\text{m}$	$\text{dB}(\mu\text{V})/\text{m}$
0.009 ~ 0.490	300	2400/F(KHz)	67.6-20log(F)
0.490 ~ 1.705	30	24000/F(KHz)	87.6-20log(F)
1.705 ~ 30.0	30	30	29.54
30 ~ 88	3	100	40.0
88 ~ 216	3	150	43.5
216 ~ 960	3	200	46.0
960 ~ 1000	3	500	54.0
Above 1000	3	74.0 dB(μV)/m (Peak) 54.0 dB(μV)/m (Average)	

Note: (1) The emission limits shown in the above table are based on measurements employing a CISPR QP detector except for the frequency bands 9-90KHz, 110-490KHz and above 1000MHz. Radiated emissions limits in these three bands are based on measurements employing an average detector.

(2) At frequencies below 30MHz, measurement may be performed at a distance closer than that specified, and the limit at closer measurement distance can be extrapolated by below formula:

$$\text{Limit}_{3\text{m}}(\text{dBuV}/\text{m}) = \text{Limit}_{30\text{m}}(\text{dBuV}/\text{m}) + 40\text{Log}(30\text{m}/3\text{m})$$

9.3.3. Limit for this EUT

All the emissions appearing within 15.205 restricted frequency bands shall not exceed the limits shown in 15.209, all the other emissions shall be at least 30dB below the fundamental emissions, or comply with 15.209 limits.

7.4. Test Procedure

- (1) EUT was placed on a non-metallic table, 80 cm above the ground plane inside a semi-anechoic chamber.
- (2) Setup EUT and assistant system according clause 2.4 and 7.2
- (3) Test antenna was located 3m(except 18GHz-40GHz was 1m) from the EUT on an adjustable mast, and the antenna used as below table.

Test frequency range	Test antenna used
9KHz-30MHz	Active Loop antenna
30MHz-1GHz	Trilog Broadband Antenna
1GHz-18GHz	Double Ridged Horn Antenna(1GHz-18GHz)
18GHz-40GHz	Horn Antenna(18GHz-40GHz)

According ANSI C63.10:2013 clause 6.4.4.2 and 6.5.3, for measurements below 30 MHz, the loop antenna was positioned with its plane vertical from the EUT and rotated about its vertical axis for maximum response at each azimuth position around the EUT. And the loop antenna also be positioned with its plane horizontal at the specified distance from the EUT. The center of the loop is 1 m above the ground. for measurement above 30MHz, the Trilog Broadband Antenna or Horn Antenna was located 3m from EUT, Measurements were made with the antenna positioned in both the horizontal and vertical planes of Polarization, and the measurement antenna was varied from 1 m to 4 m. in height above the reference ground plane to obtain the maximum signal strength.

- (4) Below pre-scan procedure was first performed in order to find prominent frequency spectrum radiated emissions from 9KHz to 25GHz:
 - (a) Scanning the peak frequency spectrum with the antenna specified in step (3), and the EUT was rotated 360 degree, the antenna height was varied from 1m to 4m(Except loop antenna, it's fixed 1m above ground.)
 - (b) Change work frequency or channel of device if practicable.
 - (c) Change modulation type of device if practicable.
 - (d) new battery is used during testing
 - (e) Rotated EUT though three orthogonal axes to determine the attitude of EUT arrangement produces highest emissions.

Spectrum frequency from 9KHz to 25GHz (tenth harmonic of fundamental frequency) was investigated, and no any obvious emission were detected from 18GHz to 25GHz, so below final test was performed with frequency range from 9KHz to 18GHz.

- (5) For final emissions measurements at each frequency of interest, the EUT was rotated and the antenna height was varied between 1m and 4m in order to maximize the emission. Measurements in both horizontal and vertical polarities were made and the data was recorded. In order to find the maximum emission, the relative positions of equipments and all of the interface cables were changed according to ANSI C63.10 2013 on Radiated Emission test.
- (6) The emissions from 9KHz to 1GHz were measured based on CISPR QP detector except for the frequency bands 9-90KHz, 110-490KHz, for emissions from 9KHz-90KHz, 110KHz-490KHz and above 1GHz were measured based on average detector, for emissions above 1GHz, peak emissions also be measured and need comply with Peak limit.
- (7) The emissions from 9KHz to 1GHz, QP or average values were measured with EMI receiver with below RBW

Frequency band	RBW
9KHz-150KHz	200Hz
150KHz-30MHz	9KHz
30MHz-1GHz	120KHz

- (8) For emissions above 1GHz, both Peak and Average level were measured with Spectrum Analyzer, and the RBW is set at 1MHz, VBW is set at 3MHz for Peak measure; RBW is set at 1MHz, VBW is set at 10Hz for Average measure(according ANSI C63.10:2013 clause 4.2.3.2.3 procedure for average measure). Peak detector is used for Peak and AV measurement both.

7.5. Test result(Below 30MHz)

EUT:	14" Notebook PC	Model No.:	CW140
Temperature:	24°C	Relative Humidity:	55%
Distance:	3m	Test Power:	120V 60Hz
Polarization:	--	Test Result:	Pass
Test Mode:	Keeping TX mode	Test By:	Smile

Freq. (MHz)	Reading (dBuV/m)	Limit (dBuV/m)	Margin (dB)	State P/F
--	--	--	--	P
--	--	--	--	P

Note:

The amplitude of spurious emissions which are attenuated by more than 20dB below the permissible value has no need to be reported.

Distance extrapolation factor = $20 \log(\text{specific distance}/\text{test distance})$ (dB);

Limit line = specific limits(dBuv) + distance extrapolation factor.

Note: The worst data is Antenna A, only shown Antenna A Plot.

TEST RESULTS (Between 30M – 1000 MHz)

EUT:	14" Notebook PC	Model No.:	CW140
Temperature:	24	Relative Humidity:	55%
Distance:	3m	Test Power:	AC120V/60Hz
Polarization:	Vertical	Test Result:	Pass
Standard:	(RE)FCC PART 15	Test By:	Smile
Test Mode:	Keeping TX mode		

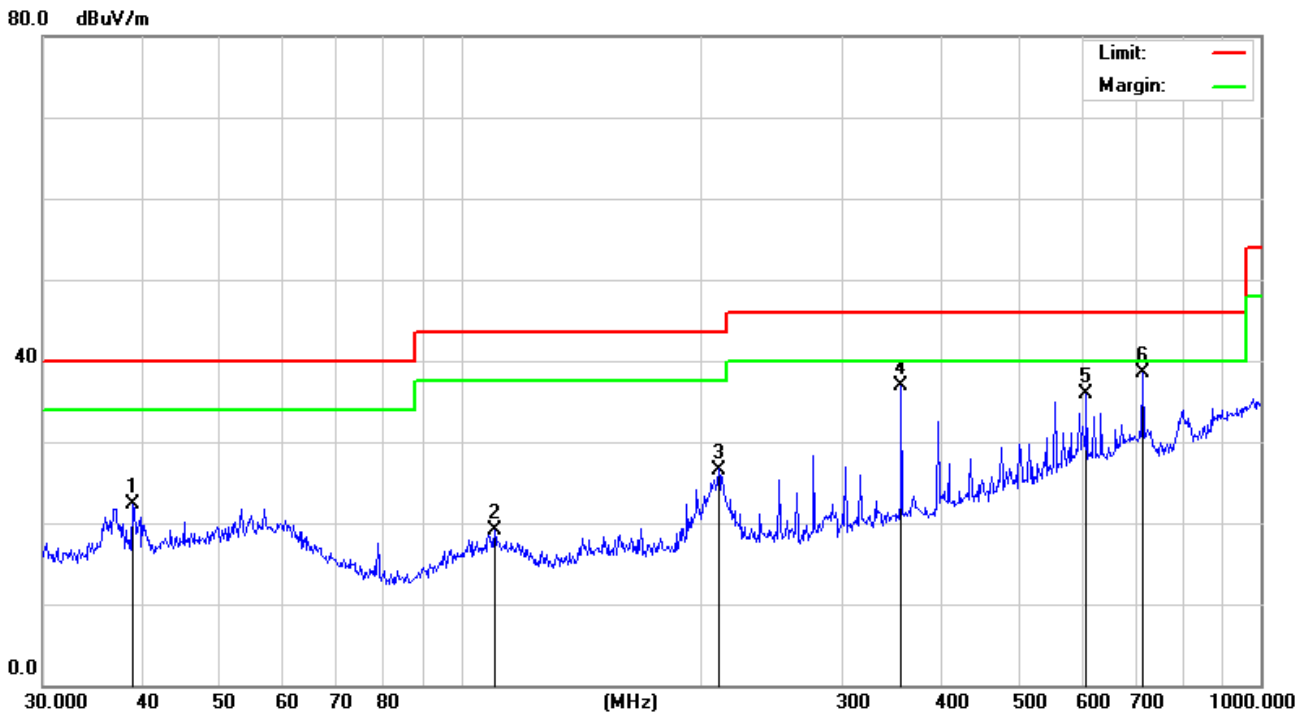

No.	Mk.	Freq. MHz	Reading Level dBuV	Correct Factor dB	Measure- ment dBuV/m	Limit dBuV/m	Over dB	Detector
1		38.8878	34.33	-12.11	22.22	40.00	-17.78	QP
2		110.1816	32.14	-13.03	19.11	43.50	-24.39	QP
3		210.0482	38.27	-11.67	26.60	43.50	-16.90	QP
4		355.4273	44.75	-7.78	36.97	46.00	-9.03	QP
5		605.6592	37.38	-1.44	35.94	46.00	-10.06	QP
6	*	711.6734	39.06	-0.47	38.59	46.00	-7.41	QP

The test result is calculated as the following:

- (1) Result = Reading + Correct Factor
- (2) Correct Factor = Antenna Factor + Cable Loss – Amplifier Gain + Attenuator
- (3) Margin = Result - Limit

EUT:	14" Notebook PC	Model No.:	CW140
Temperature:	24	Relative Humidity:	55%
Distance:	3m	Test Power:	AC120V/60Hz
Polarization:	Horizontal	Test Result:	Pass
Standard:	(RE)FCC PART 15	Test By:	Smile
Test Mode:	Keeping TX mode		

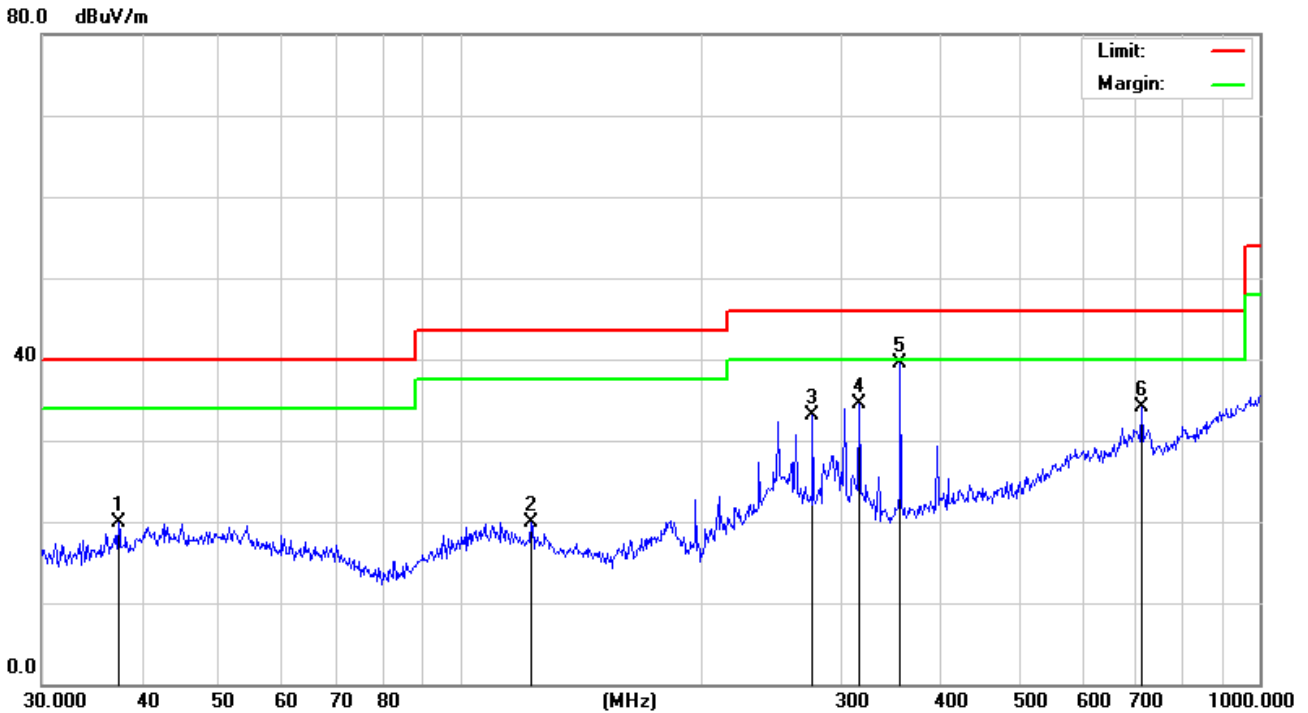

No.	Mk.	Freq. MHz	Reading Level dBuV	Correct Factor dB	Measure- ment dBuV/m	Limit dBuV/m	Over dB	Detector
1		37.4165	31.98	-12.07	19.91	40.00	-20.09	QP
2		122.8340	32.90	-13.04	19.86	43.50	-23.64	QP
3		276.1235	44.85	-11.79	33.06	46.00	-12.94	QP
4		315.4808	43.40	-8.99	34.41	46.00	-11.59	QP
5	*	355.4273	47.38	-7.78	39.60	46.00	-6.40	QP
6		711.6734	34.65	-0.47	34.18	46.00	-11.82	QP

The test result is calculated as the following:

- (1) Result = Reading + Correct Factor
- (2) Correct Factor = Antenna Factor + Cable Loss – Amplifier Gain + Attenuator
- (3) Margin = Result - Limit

TEST RESULTS (Above 1000 MHz)

EUT:	14" Notebook PC	Model No.:	CW140
Temperature:	24°C	Relative Humidity:	55%
Distance:	3m	Test Power:	120V 60Hz
Polarization:		Test Result:	Pass
Test Mode:	TX-802.11a/n20/n40/ac20/ac40/ac/80	Test By:	Smile

Above 1GHz:

Mode	Polar (H/V)	Frequency (MHz)	Reading (dBμV)	Factor (dB)	Result (dBμV)	Limit (dBμV/m)	Margin (dB)	Detector (PK/AV)
802.11a-5180MHz	H	10360	34.42	12.56	46.98	74.00	-27.02	PEAK
	H	15540	36.28	16.45	52.73	74.00	-21.27	PEAK
	V	10360	35.18	12.56	47.74	74.00	-26.26	PEAK
	V	15540	36.55	16.45	53.00	74.00	-21.00	PEAK

802.11a-5200 MHz	H	10400	35.46	12.64	48.10	74.00	-25.90	PEAK
	H	15600	35.51	16.53	52.04	74.00	-21.96	PEAK
	V	10400	37.46	12.64	50.10	74.00	-23.90	PEAK
	V	15600	35.24	16.53	51.77	74.00	-22.23	PEAK

802.11a-5240 MHz	H	10480	33.52	12.68	46.20	74.00	-27.80	PEAK
	H	15720	34.83	16.54	51.37	74.00	-22.63	PEAK
	V	10480	35.96	12.68	48.64	74.00	-25.36	PEAK
	V	15720	34.00	16.54	50.54	74.00	-23.46	PEAK

802.11a-5745 MHz	H	11490	33.12	16.82	49.94	74.00	-24.06	PEAK
	H	17235	29.50	22.93	52.43	74.00	-21.57	PEAK
	V	11490	31.62	16.82	48.44	74.00	-25.56	PEAK
	V	17235	29.80	22.93	52.73	74.00	-21.27	PEAK

802.11a-5785 MHz	H	11570	32.43	16.71	49.14	74.00	-24.86	PEAK
	H	17355	27.53	24.37	51.90	74.00	-22.10	PEAK
	V	11570	29.74	16.71	46.45	74.00	-27.55	PEAK
	V	17355	28.58	24.37	52.95	74.00	-21.05	PEAK

802.11a-5825 MHz	H	11650	33.99	16.61	50.60	74.00	-23.40	PEAK
	H	17475	27.37	25.01	52.38	74.00	-21.62	PEAK
	V	11650	32.56	16.61	49.17	74.00	-24.83	PEAK
	V	17475	28.84	25.01	53.85	74.00	-20.15	PEAK

Mode	Polar (H/V)	Frequency (MHz)	Reading (dB μ V)	Factor (dB)	Result (dB μ V)	Limit (dB μ V/m)	Margin (dB)	Detector (PK/AV)
802.11n HT20-5180MHz	H	10360	33.27	12.56	45.83	74.00	-28.17	PEAK
	H	15540	35.19	16.45	51.64	74.00	-22.36	PEAK
	V	10360	35.39	12.56	47.95	74.00	-26.05	PEAK
	V	15540	35.47	16.45	51.92	74.00	-22.08	PEAK
802.11n HT20-5200MHz	H	10400	34.98	12.64	47.62	74.00	-26.38	PEAK
	H	15600	32.80	16.53	49.33	74.00	-24.67	PEAK
	V	10400	35.48	12.64	48.12	74.00	-25.88	PEAK
	V	15600	35.43	16.53	51.96	74.00	-22.04	PEAK
802.11n HT20-5240MHz	H	10480	34.70	12.68	47.38	74.00	-26.62	PEAK
	H	15720	32.45	16.54	48.99	74.00	-25.01	PEAK
	V	10480	34.71	12.68	47.39	74.00	-26.61	PEAK
	V	15720	33.27	16.54	49.81	74.00	-24.19	PEAK
802.11n HT20-5745MHz	H	11490	30.65	16.82	47.47	74.00	-26.53	PEAK
	H	17235	29.80	22.93	52.73	74.00	-21.27	PEAK
	V	11570	32.09	16.71	48.80	74.00	-25.20	PEAK
	V	17235	28.00	22.93	50.93	74.00	-23.07	PEAK
802.11n HT20-5785MHz	H	11570	30.31	16.71	47.02	74.00	-26.98	PEAK
	H	17355	28.85	24.37	53.22	74.00	-20.78	PEAK
	V	11570	32.85	16.71	49.56	74.00	-24.44	PEAK
	V	17355	29.07	24.37	53.44	74.00	-20.56	PEAK
802.11n HT20-5825MHz	H	11650	32.23	16.61	48.84	74.00	-25.16	PEAK
	H	17475	27.65	25.01	52.66	74.00	-21.34	PEAK
	V	11650	34.26	16.61	50.87	74.00	-23.13	PEAK
	V	17475	28.35	25.01	53.36	74.00	-20.64	PEAK
802.11n HT40-5190MHz	H	10380	35.22	12.58	47.80	74.00	-26.20	PEAK
	H	15570	33.70	16.48	50.18	74.00	-23.82	PEAK
	V	10380	37.17	12.58	49.75	74.00	-24.25	PEAK
	V	15570	33.46	16.48	49.94	74.00	-24.06	PEAK

Mode	Polar (H/V)	Frequency (MHz)	Reading (dB μ V)	Factor (dB)	Result (dB μ V)	Limit (dB μ V/m)	Margin (dB)	Detector (PK/AV)
802.11n HT40-5230MHz	H	10460	36.54	12.66	49.20	74.00	-24.80	PEAK
	H	15690	34.58	16.53	51.11	74.00	-22.89	PEAK
	V	10460	36.11	12.66	48.77	74.00	-25.23	PEAK
	V	15690	33.69	16.53	50.22	74.00	-23.78	PEAK
802.11n HT40-5755MHz	H	11510	31.76	16.78	48.54	74.00	-25.46	PEAK
	H	17265	27.40	23.29	50.69	74.00	-23.31	PEAK
	V	11510	33.72	16.78	50.50	74.00	-23.50	PEAK
	V	17265	28.95	23.29	52.24	74.00	-21.76	PEAK
802.11n HT40-5795MHz	H	11590	30.83	16.69	47.52	74.00	-26.48	PEAK
	H	17385	26.76	24.73	51.49	74.00	-22.51	PEAK
	V	11590	32.37	16.69	49.06	74.00	-24.94	PEAK
	V	17385	27.81	24.73	52.54	74.00	-21.46	PEAK
802.11ac HT20-5180MHz	H	10360	34.27	12.56	46.83	74.00	-27.17	PEAK
	H	15540	33.84	16.45	50.29	74.00	-23.71	PEAK
	V	10360	33.00	12.56	45.56	74.00	-28.44	PEAK
	V	15540	35.12	16.45	51.57	74.00	-22.43	PEAK
802.11ac HT20-5200MHz	H	10400	34.27	12.64	46.91	74.00	-27.09	PEAK
	H	15600	30.98	16.53	47.51	74.00	-26.49	PEAK
	V	10400	33.35	12.64	45.99	74.00	-28.01	PEAK
	V	15600	31.79	16.53	48.32	74.00	-25.68	PEAK
802.11ac HT20-5240MHz	H	10480	33.47	12.68	46.15	74.00	-27.85	PEAK
	H	15720	32.04	16.54	48.58	74.00	-25.42	PEAK
	V	10480	32.17	12.68	44.85	74.00	-29.15	PEAK
	V	15720	34.02	16.54	50.56	74.00	-23.44	PEAK
802.11ac HT20-5745MHz	H	11490	32.26	16.82	49.08	74.00	-24.92	PEAK
	H	17235	29.63	22.93	52.56	74.00	-21.44	PEAK
	V	11490	31.37	16.82	48.19	74.00	-25.81	PEAK
	V	17235	28.71	22.93	51.64	74.00	-22.36	PEAK

Mode	Polar (H/V)	Frequency (MHz)	Reading (dB μ V)	Factor (dB)	Result (dB μ V)	Limit (dB μ V/m)	Margin (dB)	Detector (PK/AV)
802.11ac HT20-5785MHz	H	11570	32.68	16.71	49.39	74.00	-24.61	PEAK
	H	17355	27.14	24.37	51.51	74.00	-22.49	PEAK
	V	11570	31.76	16.71	48.47	74.00	-25.53	PEAK
	V	17355	27.38	24.37	51.75	74.00	-22.25	PEAK
802.11ac HT20-5825MHz	H	11650	31.89	16.61	48.50	74.00	-25.50	PEAK
	H	17475	26.87	25.01	51.88	74.00	-22.12	PEAK
	V	11650	32.11	16.61	48.72	74.00	-25.28	PEAK
	V	17475	28.03	25.01	53.04	74.00	-20.96	PEAK
802.11ac HT40-5190MHz	H	10380	33.51	12.58	46.09	74.00	-27.91	PEAK
	H	15570	34.88	16.48	51.36	74.00	-22.64	PEAK
	V	10380	34.22	12.58	46.80	74.00	-27.20	PEAK
	V	15570	32.23	16.48	48.71	74.00	-25.29	PEAK
802.11ac HT40-5230MHz	H	10460	34.18	12.66	46.84	74.00	-27.16	PEAK
	H	15690	31.87	16.53	48.40	74.00	-25.60	PEAK
	V	10460	33.87	12.66	46.53	74.00	-27.47	PEAK
	V	15690	32.38	16.53	48.91	74.00	-25.09	PEAK
802.11ac HT40-5755MHz	H	11510	31.68	16.78	48.46	74.00	-25.54	PEAK
	H	17265	27.25	23.29	50.54	74.00	-23.46	PEAK
	V	11510	32.16	16.78	48.94	74.00	-25.06	PEAK
	V	17265	27.27	23.29	50.56	74.00	-23.44	PEAK
802.11ac HT40-5795MHz	H	11590	32.36	16.69	49.05	74.00	-24.95	PEAK
	H	17385	26.89	24.73	51.62	74.00	-22.38	PEAK
	V	11590	31.03	16.69	47.72	74.00	-26.28	PEAK
	V	17385	27.68	24.73	52.41	74.00	-21.59	PEAK
802.11ac HT80-5210MHz	H	10420	32.86	12.62	45.48	74.00	-28.52	PEAK
	H	15630	33.17	16.52	49.69	74.00	-24.31	PEAK
	V	10420	33.69	12.62	46.31	74.00	-27.69	PEAK
	V	15630	32.10	16.52	48.62	74.00	-25.38	PEAK

Mode	Polar (H/V)	Frequency (MHz)	Reading (dB μ V)	Factor (dB)	Result (dB μ V)	Limit (dB μ V/m)	Margin (dB)	Detector (PK/AV)
802.11ac HT80-5775MHz	H	11550	32.35	16.73	49.08	74.00	-24.92	PEAK
	H	17325	25.96	24.01	49.97	74.00	-24.03	PEAK
	V	11550	29.42	16.73	46.15	74.00	-27.85	PEAK
	V	17325	25.86	24.01	49.87	74.00	-24.13	PEAK

The field strength is calculated by adding the Antenna Factor. Cable Factor & Preamplifier. The basic equation with a sample calculation is as follows:

Final Test Level = Receiver Reading + Antenna Factor + Cable Factor – Preamplifier Factor.

Average measurement was not performed if peak level lower than average limit.

No any other emissions level very low which are attenuated less than 20dB below the limit.

According to 15.31(o), The amplitude of spurious emissions from intentional radiators and emissions from unintentional radiators which are attenuated more than 20 dB below the permissible value need not be reported unless specifically required elsewhere in this Part.

Hence there no other emissions have been reported.

8. FREQUENCY STABILITY

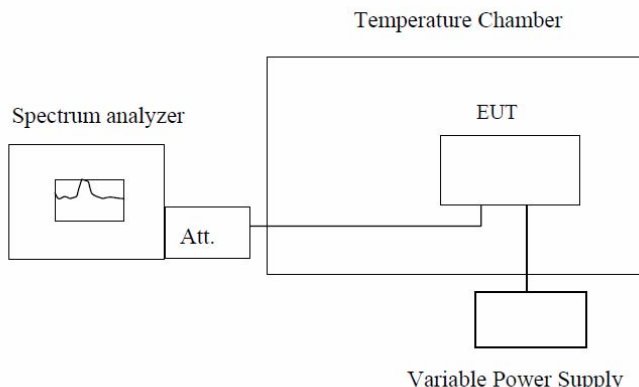
Test Requirement:	FCC Part15 C Section 15.407(g)
Test Method:	ANSI C63.10:2013, FCC Part 2.1055
Limit:	Manufactures of U-NII devices are responsible for ensuring frequency stability such that an emission is maintained within the band of operation under all conditions of normal operation as specified
Test Procedure:	The EUT was setup to ANSI C63.4, 2014; tested to 2.1055 for compliance to FCC Part 15.407(g) requirements.
Test setup:	 <p style="text-align: center;">Temperature Chamber</p> <p style="text-align: center;">Spectrum analyzer</p> <p style="text-align: center;">Att.</p> <p style="text-align: center;">EUT</p> <p style="text-align: center;">Variable Power Supply</p> <p>Note : Measurement setup for testing on Antenna connector</p>
Test Instruments:	Refer to section 5.10 for details
Test mode:	Refer to section 5.3 for details
Test results:	Pass

Frequency stability versus Temp.					
Power Supply: DC 7.6V					
Temp. (°C)	Operating Frequency (MHz)	0 minute	2 minute	5 minute	10 minute
		Measured Frequency (MHz)	Measured Frequency (MHz)	Measured Frequency (MHz)	Measured Frequency (MHz)
-30	5180	5179.9851	5180.0325	5180.4243	5179.8851
	5200	5199.9887	5200.8674	5200.0368	5199.3205
	5220	5219.8385	5220.2866	5220.5323	5219.9977
	5240	5239.9173	5240.6691	5240.1408	5239.6889
	5745	5744.9699	5745.0636	5745.1019	5745.0985
	5785	5784.9074	5784.9975	5784.9975	5785.0576
	5825	5825.0392	5825.0404	5825.0378	5824.9001
-20	5180	5179.8393	5180.3932	5180.6309	5179.8981
	5200	5199.5445	5200.4329	5200.1145	5199.8137
	5220	5219.3904	5220.5572	5220.1686	5219.7308
	5240	5239.3124	5240.1979	5240.4948	5239.0904
	5745	5744.9871	5744.9491	5744.9558	5745.0667
	5785	5784.9856	5785.0269	5785.0027	5784.9285
	5825	5824.8893	5825.0313	5824.9766	5824.9976
-10	5180	5179.0313	5180.2901	5180.1433	5179.0527
	5200	5199.9074	5200.8186	5200.9223	5199.1326
	5220	5219.6714	5220.6999	5220.2465	5219.4942
	5240	5239.4516	5240.5887	5240.8541	5239.3089
	5745	5744.9924	5744.9925	5744.9191	5745.0357
	5785	5785.0051	5784.9180	5785.0638	5784.9411
	5825	5824.9582	5824.9282	5824.9622	5825.0374
0	5180	5180.0406	5180.5023	5180.2690	5179.3058
	5200	5199.3880	5200.6207	5200.7714	5199.8940
	5220	5219.1172	5219.9288	5219.9315	5219.9605
	5240	5239.3459	5240.7156	5240.2078	5239.5413
	5745	5744.9264	5744.9970	5744.9918	5745.0028
	5785	5785.0458	5785.0354	5784.9128	5784.9062
	5825	5825.0608	5824.9696	5825.0615	5824.9563

10	5180	5179.8851	5180.0525	5180.0572	5179.9188
	5200	5199.8381	5200.0890	5200.5907	5199.7525
	5220	5219.0867	5220.2183	5220.0057	5219.9324
	5240	5239.7521	5240.5209	5240.6402	5239.6259
	5745	5744.9405	5745.0307	5745.0832	5745.0298
	5785	5785.0258	5785.0312	5784.9168	5785.0867
	5825	5824.9331	5825.0634	5824.9564	5825.0592
20	5180	5179.8889	5180.1389	5180.3615	5179.4115
	5200	5199.6082	5200.3240	5200.7251	5199.3655
	5220	5219.3693	5220.7622	5220.3731	5219.5533
	5240	5239.1733	5240.8387	5240.3451	5239.2893
	5745	5745.0172	5744.9114	5745.0491	5744.9063
	5785	5784.9835	5784.9385	5784.8931	5785.0233
	5825	5824.9719	5825.0210	5825.0635	5825.0438
30	5180	5179.7684	5180.0652	5180.2824	5179.7798
	5200	5199.3054	5200.2544	5200.3376	5199.6284
	5220	5219.3163	5220.4599	5220.9866	5219.4985
	5240	5239.6361	5240.2661	5240.7847	5240.0611
	5745	5744.9911	5745.0003	5744.9374	5745.0625
	5785	5785.0457	5784.8903	5784.8766	5784.8890
	5825	5825.0448	5824.9861	5824.8955	5824.9126
40	5180	5179.8191	5180.6217	5180.2036	5180.0040
	5200	5199.4007	5200.7282	5200.8556	5199.7747
	5220	5219.3659	5220.5692	5220.6015	5219.7167
	5240	5239.2452	5240.8482	5240.7042	5240.0925
	5745	5744.9339	5744.9204	5745.0467	5745.0845
	5785	5785.0129	5785.0445	5784.9446	5785.0723
	5825	5825.0540	5825.0885	5825.0309	5824.9141
50	5180	5179.3936	5180.5785	5180.4377	5179.1751
	5200	5199.3415	5200.8569	5200.3002	5199.3288
	5220	5219.7840	5220.8092	5220.5141	5219.4365
	5240	5239.4769	5240.2523	5239.9819	5239.2529
	5745	5745.0016	5745.0515	5745.0149	5744.9560
	5785	5784.9760	5784.8916	5785.0108	5785.0322
	5825	5825.0111	5824.9507	5825.0665	5825.0058

Frequency stability versus Voltage					
Temperature: 25°C					
Power Supply (VDC)	Operating Frequency (MHz)	0 minute	2 minute	5 minute	10 minute
		Measured Frequency (MHz)	Measured Frequency (MHz)	Measured Frequency (MHz)	Measured Frequency (MHz)
6.9	5180	5180.0142	5180.0120	5179.9971	5179.9633
	5200	5200.0578	5200.2292	5199.8287	5199.9889
	5220	5220.0422	5220.2345	5219.8852	5219.9183
	5240	5240.7401	5240.7331	5239.8677	5239.4377
	5745	5745.0306	5744.9194	5744.9649	5745.0410
	5785	5784.9044	5785.0544	5784.8882	5785.0420
	5825	5824.9874	5824.9161	5824.9224	5825.0343
7.6	5180	5180.9907	5180.2785	5179.2007	5179.2769
	5200	5200.2032	5200.5609	5199.8514	5199.2549
	5220	5220.0542	5220.2470	5219.7558	5219.6787
	5240	5240.0397	5240.8354	5239.2871	5239.7464
	5745	5744.9131	5744.9068	5745.0404	5745.0640
	5785	5784.9177	5785.0785	5785.0131	5785.0710
	5825	5825.0059	5824.8926	5824.9937	5824.9180
8.4	5180	5180.1292	5180.5565	5179.2373	5179.2581
	5200	5200.3795	5200.4721	5199.1327	5199.2825
	5220	5219.9464	5220.7172	5219.0524	5219.2909
	5240	5240.7065	5240.4803	5239.5411	5239.0982
	5745	5744.8726	5744.9666	5745.0519	5744.9040
	5785	5784.8982	5784.9097	5784.8771	5784.9306
	5825	5824.9227	5824.9370	5824.9048	5824.9965

9. POWER LINE CONDUCTED EMISSION

9.1 Test equipment

Item	Kind of Equipment	Manufacturer	Type No.	Serial No.	Calibrated until
1	Pulse Limiter	MTS-systemtechnik	MTS-IMP-136	261115-010-0024	12/17/2018
2	EMI Test Receiver	R&S	ESCI	101308	12/17/2018
3	LISN	AFJ	LS16	16011103219	12/17/2018
4	LISN	Schwarzbeck	NSLK 8127	8127-432	12/17/2018
5	Measurement Software	Farad	EZ-EMC (Ver.ATT-03A)	N/A	N/A
6	MeasurementSoftware	Farad	EZ-EMC (Ver.ATT-03A)	N/A	N/A

9.2 Block diagram of test setup

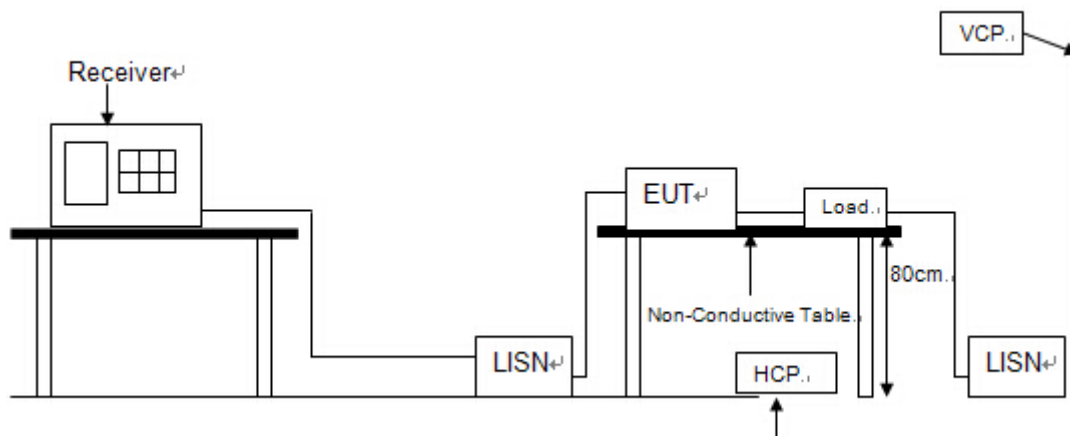

9.3 Power Line Conducted Emission Limits(Class B)

Frequency	Quasi-Peak Level dB(μ V)	Average Level dB(μ V)
150kHz ~ 500kHz	66 ~ 56*	56 ~ 46*
500kHz ~ 5MHz	56	46
5MHz ~ 30MHz	60	50

Note 1: * Decreasing linearly with logarithm of frequency.

Note 2: The lower limit shall apply at the transition frequencies.

9.4 TEST PROCEDURE

The EUT and Support equipment, if needed, were put placed on a non-metallic table, 80cm above the ground plane.

Configuration EUT to simulate typical usage as described in clause 2.4 and test equipment as described in clause 10.2 of this report.

All I/O cables were positioned to simulate typical actual usage as per ANSI C63.4.

All support equipment power received from a second LISN.

Emissions were measured on each current carrying line of the EUT using an EMI Test Receiver connected to the LISN powering the EUT.

The Receiver scanned from 150 kHz to 30MHz for emissions in each of the test modes.

During the above scans, the emissions were maximized by cable manipulation.

The test mode(s) described in clause 2.4 were scanned during the preliminary test.

After the preliminary scan, we found the test mode producing the highest emission level.

The EUT configuration and worse cable configuration of the above highest emission levels were recorded for reference of the final test.

EUT and support equipment were set up on the test bench as per the configuration with highest emission level in the preliminary test.

A scan was taken on both power lines, Neutral and Line, recording at least the six highest emissions.

Emission frequency and amplitude were recorded into a computer in which correction factors were used to calculate the emission level and compare reading to the applicable limit.

The test data of the worst-case condition(s) was recorded.

The bandwidth of test receiver is set at 9 KHz.

9.5 Test Result

PASS. (See below detailed test result)

Note1: All emissions not reported below are too low against the prescribed limits.

Note2: "-----" means peak detection; "-----" mans average detection

EUT:	Table PC	Model No.:	CW140
Temperature:	23°C	Relative Humidity:	52%
Probe:	N	Test Power:	AC 120V/60Hz
Test Time:	2018-9-20	Test Result:	Pass
Standard:	(CE)FCC PART 15 class B_QP		
Test Mode:	TX		
Note:			

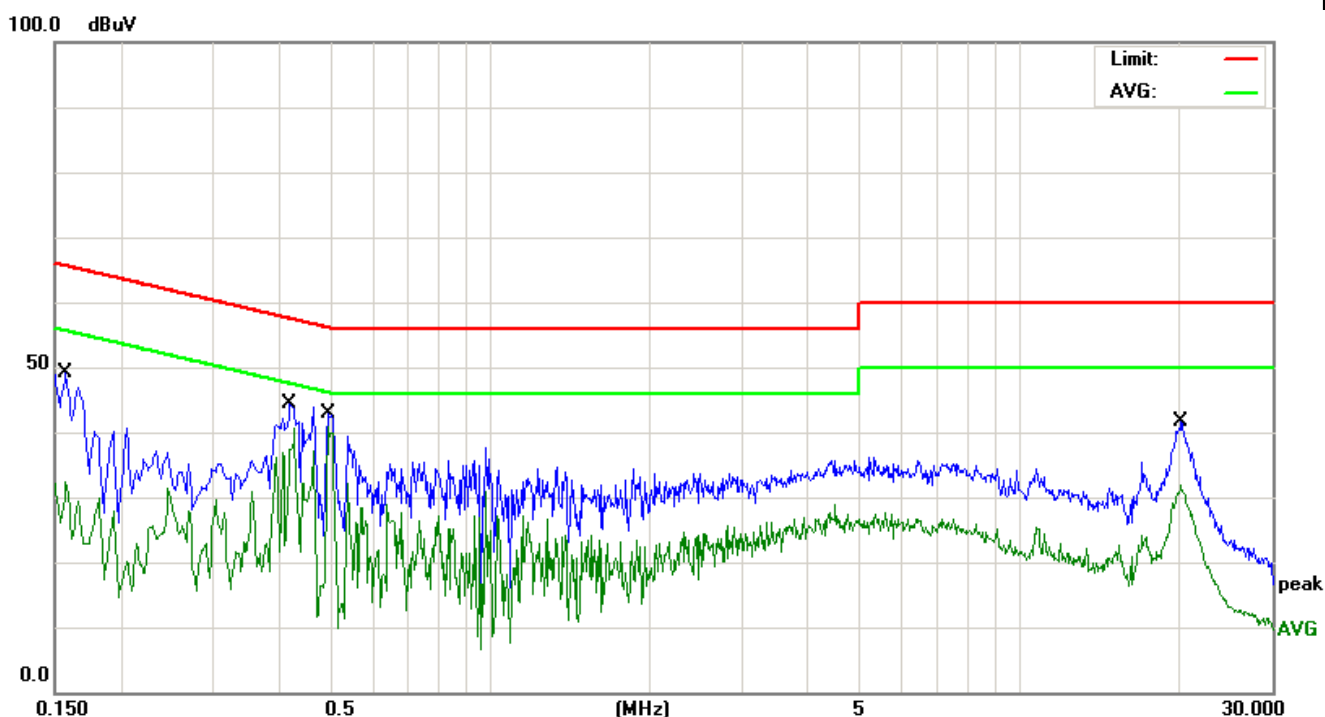

No.	Mk.	Freq. MHz	Reading Level dBuV	Correct Factor dB	Measure- ment dBuV	Limit dBuV	Over dB	Detector
1		0.1580	37.34	11.75	49.09	65.56	-16.47	QP
2		0.1580	20.59	11.75	32.34	55.56	-23.22	AVG
3		0.4180	34.15	10.10	44.25	57.49	-13.24	QP
4	*	0.4940	30.78	10.02	40.80	46.10	-5.30	AVG
5		20.2260	30.63	11.09	41.72	60.00	-18.28	QP
6		20.2260	20.68	11.09	31.77	50.00	-18.23	AVG

The test result is calculated as the following:

- (1) Result = Reading + Correct Factor
- (2) Correct Factor = (LISN, ISN, PLC or Current Probe) Factor + Cable Loss + Attenuator
- (3) Margin = Result - Limit

EUT:	Table PC	Model No.:	CW140
Temperature:	23°C	Relative Humidity:	52%
Probe:	L1	Test Power:	AC 120V/60Hz
Test Time:	2018-9-20	Test Result:	Pass
Standard:	(CE)FCC PART 15 class B_QP		
Test Mode:	TX		
Note:			

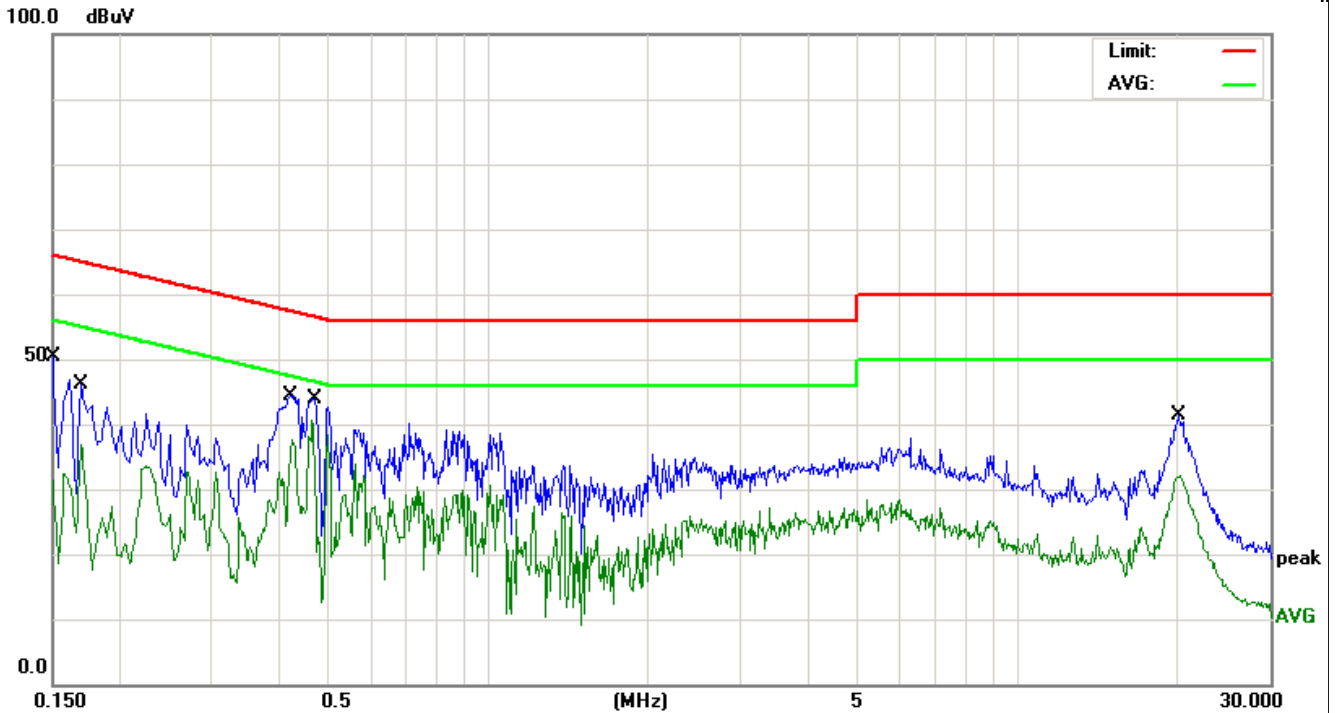

No.	Mk.	Freq.	Reading Level	Correct Factor	Measurement	Limit	Over	Detector
		MHz	dBuV	dB	dBuV	dBuV	dB	
1		0.1500	38.47	11.94	50.41	65.99	-15.58	QP
2		0.1700	25.38	11.55	36.93	54.96	-18.03	AVG
3		0.4220	34.27	10.11	44.38	57.41	-13.03	QP
4	*	0.4660	30.50	10.05	40.55	46.58	-6.03	AVG
5		20.2460	30.23	11.09	41.32	60.00	-18.68	QP
6		20.2700	20.97	11.09	32.06	50.00	-17.94	AVG

The test result is calculated as the following:

- (1) Result = Reading + Correct Factor
- (2) Correct Factor = (LISN, ISN, PLC or Current Probe) Factor + Cable Loss + Attenuator
- (3) Margin = Result - Limit

10. ANTENNA REQUIREMENTS

10.1. Limit

15.203 requirement: For intentional device, according to 15.203: an intentional radiator shall be designed to ensure that no antenna other than that furnished by the responsible party shall be used with the device.

10.2. EUT ANTENNA

The EUT antenna is permanent attached antenna. It comply with the standard requirement.