

TEST REPORT

of

FCC PART 15 SUBPART E

New Application; Class I PC; Class II PC

Product : AIoT Module
Brand: Winstec
Model: SM35B02
Model Difference: N/A
FCC ID: 2AOAOSM35B02
FCC Rule Part: §15.407, Cat:NII
Applicant: Winstec Corporation
Address: 9F.-2, No.160, Sec. 6, Minquan E. Rd., Neihu Dist., Taipei 114, Taiwan

Test Performed by:

International Standards Laboratory Corp. LT Lab.



TEL: +886-3-263-8888 FAX: +886-3-263-8899

No. 120, Lane 180, Hsin Ho Rd., Lung-Tan Dist., Tao Yuan City 325, Taiwan

Report No.: ISL-23LR0158FE
Issue Date : March 29, 2024



Test results given in this report apply only to the specific sample(s) tested and are traceable to national or international standard through calibration of the equipment and evaluating measurement uncertainty herein.

The uncertainty of the measurement does not include in consideration of the test result unless the customer required the determination of uncertainty via the agreement, regulation or standard document specification.

This test report shall not be reproduced except in full, without the written approval of International Standards Laboratory Corp.

VERIFICATION OF COMPLIANCE

Applicant: Winstec Corporation
Product Description: AIoT Module
Brand Name: Winstec
Model No.: SM35B02
Model Difference: N/A
FCC ID: 2AOAOSM35B02
Date of test: October 26, 2023 ~ March 29, 2024
Date of EUT Received: October 26, 2023
Test Frim TW0997

We hereby certify that:

All the tests in this report have been performed and recorded in accordance with the standards described above and performed by an independent electromagnetic compatibility consultant, International Standards Laboratory Corp.

The test results contained in this report accurately represent the measurements of the characteristics and the energy generated by sample equipment under test at the time of the test. The sample equipment tested as described in this report is in compliance with the limits of above standards.

Test By:

Bill Huang

Date:

March 29, 2024

Bill Huang / Senior Engineer

Prepared By:

Gigi yeh

Date:

March 29, 2024

Gigi Yeh / Senior Engineer

Approved By:

Jerry Liu

Date:

March 29, 2024

Jerry Liu / Manager

Version

Version No.	Date	Description
00	March 29, 2024	Initial creation of document

Uncertainty of Measurement

ISO/IEC 17025 requires that an estimate of measurement uncertainties associated with the emissions test results be included in the report. The measurement uncertainties given below are based on a 95% confidence level (based on a coverage factor (k=2)).

Parameters	Uncertainty (k=2)
Conducted Emission (AC power line)	±0.64 dB
Spurious emissions, radiated	±3.5 dB
RF power, conducted	±1.6 dB
Power Density	±1.7 dB
RF Frequency	±0.0041%
Time	±0.01%
DC Voltage	±0.03%

Table of Contents

1. General Information.....	6
1.1. Product Description	6
1.2. Related Submittal(s) / Grant (s)	8
1.3. Test Methodology	8
1.4. Test Facility.....	8
1.5. Special Accessories	8
1.6. Equipment Modifications.....	8
2. System Test Configuration.....	9
2.1. EUT Configuration	9
2.2. EUT Exercise	9
2.3. Test Procedure.....	9
2.4. Configuration of Tested System.....	10
2.5. Duty Cycle	11
3. Summary of Test Results.....	12
4. Description of Test Modes.....	13
5. Conduced Emission Test	14
5.1. Standard Applicable	14
5.2. Measurement Equipment Used:	14
5.3. EUT Setup:.....	15
5.4. Measurement Procedure:	15
5.5. Measurement Result:	15
6. OUTPUT POWER / EIRP /SPECTRAL DENSITY MEASUREMENT.....	18
6.1. Standard Applicable	18
6.2. Measurement Procedure.....	20
6.3. Measurement Equipment Used:	21
6.4. Measurement Equipment Used:	22
6.5. Measurement Result.....	23
7. 26dB /99% Emission Bandwidth Measurement.....	30
7.1. Standard Applicable	30
7.2. Measurement Procedure.....	30
7.3. Measurement Equipment Used:	30
7.4. Test Set-up:	30
7.5. Measurement Result.....	31
8. 6dB Emission Bandwidth Measurement.....	37
8.1. Standard Applicable	37
8.2. Measurement Procedure.....	37
8.3. Measurement Equipment Used:	37

8.4.	Test Set-up:	37
8.5.	Measurement Result.....	37
9.	Undesirable emission – Radiated Measurement	38
9.1.	Standard Applicable	38
9.2.	EUT Setup.....	40
9.3.	Measurement Procedure.....	41
9.4.	Test SET-UP (Block Diagram of Configuration)	42
9.5.	Measurement Equipment Used:	43
9.6.	Field Strength Calculation	44
9.7.	Measurement Result.....	44
10.	Transmission in the Absence of Data	93
10.1.	Standard Applicable	93
10.2.	Result:	93
11.	Antenna Requirement	94
11.1.	Standard Applicable	94
11.2.	Antenna Connected Construction	94
12.	TPC and DFS Measurement	95
12.1.	TPC: Standard Applicable.....	95
12.2.	DFS: Standard Applicable.....	95
12.3.	Test Equipment Used:	101
12.4.	Test results	102
	PHOTOGRAPHS OF SET UP	103
	PHOTOGRAPHS OF EUT.....	110

1. General Information

1.1. Product Description

General Information	
Product Name:	AIoT Module
Brand Name:	Winstec
Model Name:	SM35B02
Model Difference:	N/A
Temperature Range:	-20°C to +60°C
Power Supply:	5VdC from USB
WiFi Information	
WLAN Modular	RTL8735BDM N2CE7E8 GN12AA4
Frequency Range:	WLAN 5GHz Band U-NII-1 5180MHz-5240MHz
Max Output Power:	5180MHz ~ 5240MHz: 8.994 dBm
Channel number:	WLAN 5GHz Band 802.11a U-NII-1 : 4 802.11n(HT20) U-NII-1 : 4 802.11ac(VHT20) U-NII-1 : 4
Product HW Version:	2V2
Product SW Version:	N/A
Product FW Version:	9.4c MP
Test SW Version:	1v9.6
RF power setting:	a low(17.25) mid(17.25) high(17.75) HT20 low(18) mid(19) high(19.25) VHT20 low(18) mid(18.25) high(18.5)

	Antenna Type	Brand	Model	Peak Gain	Frequency Range	Connector Type
1	PCB	ShenZhen Powerful Technology CO., Limited	YL1360-WIFI-V1-L60	3.12 dBi	2400-2500 MHz	i-pex
2	PCB	ShenZhen Powerful Technology CO., Limited	YL1360-WIFI-V1-L60	4.54 dBi	5150-5850 MHz	i-pex

The EUT is compliance with IEEE 802.11 a/b/g/n/ac Standard.

This report applies for Wifi frequency band 5150 MHz– 5250 MHz.

Remark: The above DUT's information was declared by manufacturer. Please refer to the specifications or user's manual for more detailed description.

1.2. Related Submittal(s) / Grant (s)

This submittal(s) (test report) is intended for **FCC ID: 2AOAOSM35B02** filing to comply with Section 15.407 of the FCC Part 15, Subpart E Rules.

1.3. Test Methodology

Both conducted and radiated testing were performed according to the procedures in ANSI C63.10: 2013. Radiated testing was performed at an antenna to EUT distance 3 meters.

KDB Document: 789033 D02 General U-NII Test Procedures New Rules v02r01

FCC 14-30 Revision UNII

594280 D02 U-NII Device Security v01r03

1.4. Test Facility

The measurement facilities used to collect the 3m Radiated Emission and AC power line conducted data are located on the address of International Standards Laboratory Corp. <LT Lab.> No. 120, Lane 180, Hsin Ho Rd., Lung-Tan Dist., Tao Yuan City 325, Taiwan which are constructed and calibrated to meet the FCC requirements in documents ANSI C63.10: 2013. FCC Registration Number is: 487532; Designation Number is: TW0997.

1.5. Special Accessories

Not available for this EUT intended for grant.

1.6. Equipment Modifications

Not available for this EUT intended for grant.

2. System Test Configuration

2.1. EUT Configuration

The EUT configuration for testing is installed on RF field strength measurement to meet the Commissions requirement and operating in a manner which intends to maximize its emission characteristics in a continuous normal application.

2.2. EUT Exercise

The EUT (Transmitter) was operated in the engineering mode to fix the Tx frequency that was for the purpose of the measurements.

2.3. Test Procedure

2.3.1 Conducted Emissions

The EUT is a placed on as turn table which is 0.8 m above ground plane. According to the requirements in Section 6 of ANSI C63.10: 2013. Con-ducted emissions from the EUT measured in the frequency range between 0.15 MHz and 30MHz using CISPR 16-1-1 Quasi-Peak and Average detector mode.

2.3.2 Radiated Emissions

The EUT is a placed on a turntable which is 0.8 m/1.5m (Frequency above 1GHz) above the ground plane. The turntable shall rotate 360 degrees to determine the position of maximum emission level. The EUT is set 3m away from the receiving antenna which varied from 1m to 4m to find out the highest emission. And also, each emission was to be maximized by changing the polarization of receiving antenna both horizontal and vertical. To find out the maximum emission, the relative positions of this hand-held transmitter (EUT) was rotated through three orthogonal axes and measurement procedures for electric field radiated emissions above 1 GHz the EUT measurement is to be made “while keeping the antenna in the ‘cone of radiation’ from that area and pointed at the area both in azimuth and elevation, with polarization oriented for maximum response.” is still within the 3dB illumination BW of the measurement antenna according to the requirements in Section 6, 11 and 12 of ANSI C63.10: 2013.

2.4. Configuration of Tested System

Fig. 2-1 Configuration of Tested System

Radiated Emission



Equipment Used in Tested System

Item	Equipment	Mfr/Brand	Model/ Type No.	Series No.	Data Cable	Power Cord
1	NB	DELL	inspiron 15	34TL6F2	NA	280m

Note: All the above equipment/cables were placed in worse case positions to maximize emission signals during emission test.

Grounding: Grounding was in accordance with the manufacturer's requirements and conditions for the intended use.

2.5. Duty Cycle

If duty cycle of test signal is $\geq 98\%$, duty factor is not required.

If duty cycle of test signal is $< 98\%$, duty factor shall be considered.

The output power = measured power + duty factor.

Mode	ON time (ms)	Total time (ms)	Duty Cycle	Duty Factor	1/Ton (kHz)	VBW for average detector (kHz)
a	4.13	4.24	97.4%	0.114	0.242	1
HT20	3.85	3.97	96.964%	0.134	0.26	1
VHT20	4.13	4.25	97.176%	0.124	0.242	1

3. Summary of Test Results

FCC Rules	Description Of Test	Result
§15.207	AC Power Line Conducted Emission	Compliant
§15.407(a)(2)	Output Power/ EIRP/ Spectral Density Measurement	Compliant
§15.407(a)	26dB Emission Bandwidth	Compliant
§15.407(e)	6dB Emission Bandwidth	Compliant
§15.407(b)	Undesirable Emission – Radiated Measurement	Compliant
§15.407(c)	Transmission in case of Absence of Information	Compliant
§15.407(a)	Antenna Requirement	Compliant
§15.407(d)	TPC and DFS Measurement	Compliant
§15.407(i)	Device Security	Compliant

4. Description of Test Modes

The EUT has been tested under operating condition.

Test program used to control the EUT for staying in continuous transmitting mode is programmed.

5150MHz-5250MHz:

802.11a mode: Channel low (5180MHz), mid (5200MHz) and high (5240MHz) with 6Mbps lowest data rate are chosen for pre-test testing of radiated emissions.

802.11 n HT20: Channel low (5180MHz), mid (5200MHz) and high (5240MHz) with 6.5Mbps lowest data rate are chosen for pre-test testing of radiated emissions.

802.11 ac VHT20: Channel low (5180MHz), mid (5200MHz) and high (5240MHz) with 6.5Mbps lowest data rate are chosen for pre-test testing of radiated emissions.

5. Conduced Emission Test

5.1. Standard Applicable

According to §15.207, frequency range within 150kHz to 30MHz shall not exceed the Limit table as below.

Frequency range MHz	Limits dB(uV)	
	Quasi-peak	Average
0.15 to 0.50	66 to 56	56 to 46
0.50 to 5	56	46
5 to 30	60	50

Note

- 1.The lower limit shall apply at the transition frequencies
- 2.The limit decreases linearly with the logarithm of the frequency in the range 0.15 MHz to 0.50 MHz.

5.2. Measurement Equipment Used:

Location	Equipment Name	Brand	Model	S/N	Last Cal. Date	Next Cal. Date
Conduction 02	EMI Receiver 19	R&S	ESR3	102460	05/08/2023	05/08/2024
Conduction 02	Conduction 02-1 Cable	WOKEN	CFD 300-NL	Conduction 02 -1	10/17/2023	10/17/2024
Conduction 02	LISN 26	R&S	ENV216	102378	12/08/2023	12/08/2024
Conduction 02	LISN 21	R&S	ENV216	101476	08/17/2023	08/17/2024
Conduction 02	ISN T8 CAT6A_02	SCHWARZ-BECK	NTFM 8158	NTFM 8158-00370	07/07/2023	07/07/2024
Conduction 02	ISN T4 07	TESEQ	ISN T400A	30449	08/05/2023	08/05/2024
Conduction 02	ISN T8 10	TESEQ	ISN T800	42773	08/07/2023	08/07/2024
Conduction 02	CDN ISN ST08A_1	Teseq GmbH	CDN ISN ST08A	43352	09/27/2023	09/27/2024
Conduction 02	Capacitive Voltage Probe 01	SCHAFFNER	CVP 2200A	18711	02/05/2024	02/05/2025
Conduction 02	Current Probe	SCHAFFNER	SMZ 11	18030	01/30/2024	01/30/2025

5.3. EUT Setup:

1. The conducted emission tests were performed in the test site, using the setup in accordance with the ANSI C63.10: 2013
2. The AC/DC Power adaptor of EUT was plug-in LISN. The EUT was placed flushed with the rear of the table.
3. The LISN was connected with 120Vac/60Hz power source.

5.4. Measurement Procedure:

1. The EUT was placed on a table which is 0.8m above ground plane.
2. Maximum procedure was performed on the six highest emissions to ensure EUT compliance.
3. Repeat above procedures until all frequency measured were complete.
4. Both 120V & 240V have been verified, and 120V/60Hz was defined as the worst-case and record in the report.

5.5. Measurement Result:

The initial step in collecting conducted data is a spectrum analyzer peak scan of the measurement range. Significant peaks are then marked as shown on the following data page, and these signals are then quasi-peaked.

Note: Refer to next page for measurement data and plots.

AC POWER LINE CONDUCTED EMISSION TEST DATA



Address: No. 120, Lane 180, Hsin Ho Rd., Lung-Tan Dist.,
Tao Yuan City 325, Taiwan.
Tel: 03-2638888

Conducted Emission Measurement

operator: James Jiang

Date: 2023/12/5

Temperature: 23 °C

Humidity: 58 %

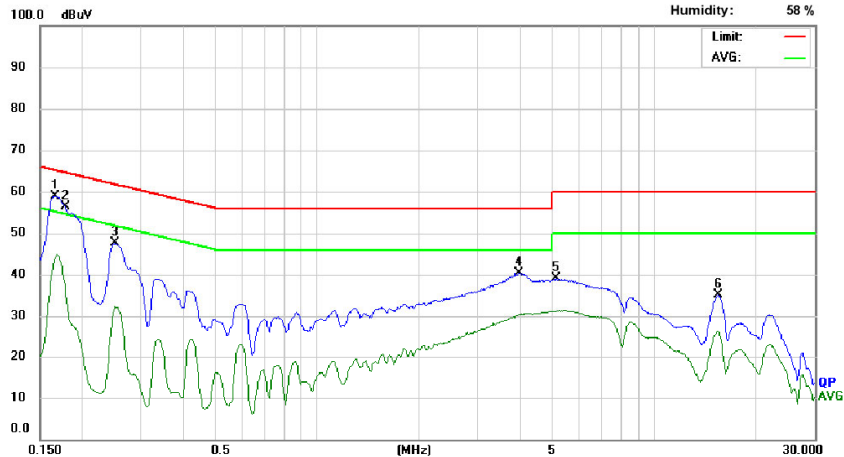

Site: Conduction 02

Phase: L1

No.	Frequency (MHz)	QP_R (dBuV)	AVG_R (dBuV)	Correct Factor (dB)	QP Emission (dBuV)	QP Limit (dBuV)	QP Margin (dB)	AVG Emission (dBuV)	AVG Limit (dBuV)	AVG Margin (dB)
1*	0.166	49.35	34.45	9.65	59.00	65.17	-6.17	44.10	55.17	-11.07
2	0.179	45.99	24.45	9.65	55.64	64.52	-8.88	34.10	54.52	-20.42
3	0.251	37.85	22.62	9.66	47.51	61.72	-14.21	32.28	51.72	-19.44
4	3.979	30.64	20.54	9.78	40.42	56.00	-15.58	30.32	46.00	-15.68
5	5.138	29.29	21.39	9.80	39.09	60.00	-20.91	31.19	50.00	-18.81
6	15.484	25.12	16.09	9.92	35.04	60.00	-24.96	26.01	50.00	-23.99



Address: No. 120, Lane 180, Hsin Ho Rd., Lung-Tan Dist.,
Tao Yuan City 325, Taiwan.
Tel: 03-2638888

Conducted Emission Measurement

operator: James Jiang

Date: 2023/12/5

Temperature: 23 °C

Humidity: 58 %

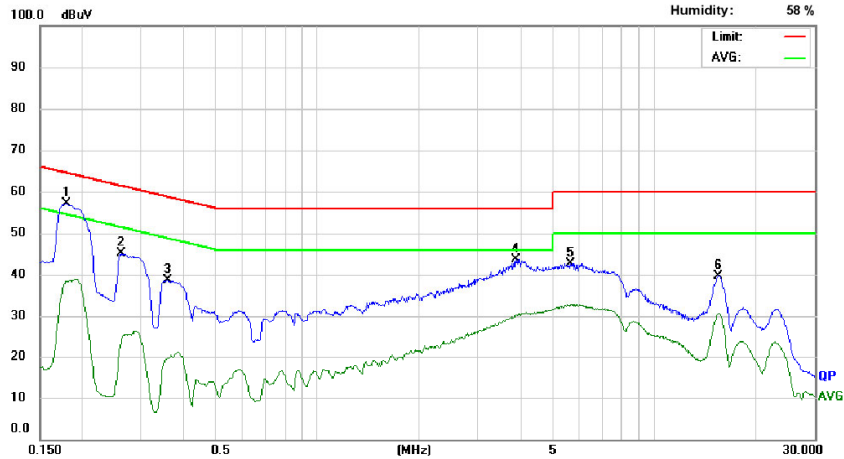

Site: Conduction 02

Phase: N

No.	Frequency (MHz)	QP_R (dBuV)	AVG_R (dBuV)	Correct Factor (dB)	QP Emission (dBuV)	QP Limit (dBuV)	QP Margin (dB)	AVG Emission (dBuV)	AVG Limit (dBuV)	AVG Margin (dB)
1*	0.179	47.46	28.81	9.64	57.10	64.52	-7.42	38.45	54.52	-16.07
2	0.260	35.38	13.99	9.65	45.03	61.43	-16.40	23.64	51.43	-27.79
3	0.359	28.96	9.87	9.65	38.61	58.74	-20.13	19.52	48.74	-29.22
4	3.885	33.81	20.57	9.77	43.58	56.00	-12.42	30.34	46.00	-15.66
5	5.633	32.94	23.16	9.81	42.75	60.00	-17.25	32.97	50.00	-17.03
6	15.544	29.70	20.54	9.98	39.68	60.00	-20.32	30.52	50.00	-19.48

6. OUTPUT POWER / EIRP /SPECTRAL DENSITY MEASUREMENT

6.1. Standard Applicable

According to §15.407(a) Power limits:

(1) For the band 5.15-5.25 GHz.

(i) For an outdoor access point operating in the band 5.15 – 5.25 GHz, the maximum conducted output power over the frequency band of operation shall not exceed 1 W provided the maximum antenna gain does not exceed 6 dBi. In addition, the maximum power spectral density shall not exceed 17 dBm in any 1 megahertz band. If transmitting antennas of directional gain greater than 6 dBi are used, both the maximum conducted output power and the maximum power spectral density shall be reduced by the amount in dB that the directional gain of the antenna exceeds 6 dBi. The maximum e.i.r.p. at any elevation angle above 30 degrees as measured from the horizon must not exceed 125 mW (21 dBm).

(ii) For an indoor access point operating in the band 5.15 – 5.25 GHz, the maximum conducted output power over the frequency band of operation shall not exceed 1 W provided the maximum antenna gain does not exceed 6 dBi. In addition, the maximum power spectral density shall not exceed 17 dBm in any 1 megahertz band. If transmitting antennas of directional gain greater than 6 dBi are used, both the maximum conducted output power and the maximum power spectral density shall be reduced by the amount in dB that the directional gain of the antenna exceeds 6 dBi.

(iii) For fixed point-to-point access points operating in the band 5.15 – 5.25 GHz, the maximum conducted output power over the frequency band of operation shall not exceed 1 W. Fixed point-to-point U-NII devices may employ antennas with directional gain up to 23 dBi without any corresponding reduction in the maximum conducted output power or maximum power spectral density. For fixed point-to-point transmitters that employ a directional antenna gain greater than 23 dBi, a 1 dB reduction in maximum conducted output power and maximum power spectral density is required for each 1 dB of antenna gain in excess of 23 dBi. Fixed, point-to-point operations exclude the use of point-to-multipoint systems, omnidirectional applications, and multiple collocated transmitters transmitting the same information. The operator of the U-NII device, or if the equipment is professionally installed, the installer, is responsible for ensuring that systems employing high gain directional antennas are used exclusively for fixed, point-to-point operations.

(iv) For mobile and portable client devices in the 5.15 – 5.25 GHz band, the maximum conducted output power over the frequency band of operation shall not exceed 250 mW provided the maximum antenna gain does not exceed 6 dBi. In addition, the maximum power spectral density shall not exceed 11 dBm in any 1 megahertz band. If transmitting antennas of directional gain greater than 6 dBi are used, both the maximum conducted output power and the maximum power spectral density shall be reduced by the amount in dB that the directional gain of the antenna exceeds 6 dBi.

(2) For the 5.25-5.35 GHz and 5.47-5.725 GHz bands, the maximum conducted output power over the frequency bands of operation shall not exceed the lesser of 250 mW or $11 \text{ dBm} + 10 \log B$, where B is the 26 dB emission bandwidth in megahertz. In addition, the maximum power spectral density shall not exceed 11 dBm in any 1 megahertz band. If transmitting antennas of directional gain greater than 6 dBi are used, both the maximum conducted output power and the maximum power spectral density shall be reduced by the amount in dB that the directional gain of the antenna exceeds 6 dBi.

(3) For the band 5.725-5.85 GHz, the maximum conducted output power over the frequency band of operation shall not exceed 1 W. In addition, the maximum power spectral density shall not exceed 30 dBm in any 500 kHz band. If transmitting antennas of directional gain greater than 6 dBi are used, both the maximum conducted output power and the maximum power spectral density shall be reduced by the amount in dB that the directional gain of the antenna exceeds 6 dBi. However, fixed point-to-point U-NII devices operating in this band may employ transmitting antennas with directional gain greater than 6 dBi without any corresponding reduction in transmitter conducted power. Fixed, point-to-point operations exclude the use of point-to-multipoint systems, omnidirectional applications, and multiple collocated transmitters transmitting the same information. The operator of the U-NII device, or if the equipment is professionally installed, the installer, is responsible for ensuring that systems employing high gain directional antennas are used exclusively for fixed, point-to-point operations.

6.2. Measurement Procedure

For Output Power

1. Place the EUT on the table and set it in transmitting mode.
2. Remove the antenna from the EUT and then connect a low loss RF cable from the antenna port to the power meter
3. Record the max. reading.
4. Repeat above procedures until all frequency measured were complete.

For Power Spectral Density

1. Place the EUT on the table and set it in transmitting mode.
2. Remove the antenna from the EUT and then connect a low loss RF cable from the antenna port to Spectrum.
3. Set RBW=1MHz,VBW=3MHz, Span=50MHz (Base Mode), Sweep time = Auto, traces 100 sweeps of video averaging for 5150-5725MHz;
4. Set RBW=500kHz,VBW=1.5MHz, Span=60MHz (Base Mode), Sweep time = Auto, traces 100 sweeps of video averaging for 5725-5850MHz;
5. Record the max. reading.
6. Repeat above procedures until all frequency measured were complete.

Refer to KDB 789033 D02 General UNII Test Procedures New Rules v02r01

6.3. Measurement Equipment Used:

Location Conducted	Equipment Name	Brand	Model	S/N	Last Cal. Date	Next Cal. Date
Conducted	Power Meter	Anritsu	ML2495A	1116010	09/27/2023	09/27/2024
Conducted	Power Sensor	Anritsu	MA2411B	34NKF50	09/27/2023	09/27/2024
Conducted	Temperature Chamber	KSON	THS-B4H100	2287	05/17/2023	05/17/2024
Conducted	DC Power supply	ABM	8185D	N/A	01/04/2023	01/04/2024
Conducted	AC Power supply	EXTECH	CFC105W	NA	N/A	N/A
Conducted	Spectrum analyzer	Keysight	N9010A	MY56070257	09/26/2023	09/26/2024
Conducted	Test Software	DARE	Radiation Ver:2013.1.23	NA	NA	NA
Conducted	Test Software	R&S	CMUGO Ver:2.0.0	N/A	N/A	N/A
Conducted	Wideband Radio Comm. Tester	R&S	CMW500	1201.002K50108 793-JG	10/26/2023	10/26/2024
Conducted	Radio Communication Test Station	Anritsu	MT8000A	6272539604	08/30/2023	08/30/2024
Conducted	MT8000A Test Software	Anritsu	MX800000A Application Launcher V10.10.5.0	NA	NA	NA
Conducted	BT Simulator	Agilent	N4010A	MY48100200	NA	NA
Conducted (TS8997)	Wideband Radio Comm. Tester	R&S	CMW500	168811	09/13/2023	09/13/2024
Conducted (TS8997)	UP/DOWN converter	R&S	CMW-Z800A	100566	09/13/2023	09/13/2024
Conducted (TS8997)	Signal Generator	R&S	SMB100A	183701	09/14/2023	09/14/2024
Conducted (TS8997)	Vector Signal Generator	R&S	SMM100A	101908	09/13/2023	09/13/2024
Conducted (TS8997)	Signal analyzer 40GHz	R&S	FSV40	101884	09/13/2023	09/13/2024
Conducted (TS8997)	OSP150 extension unit CAM-BUS	R&S	OSP150	101107	09/15/2023	09/15/2024
Conducted (TS8997)	Test Software	R&S	EMC32 Ver: 11.60.00	NA	NA	NA
Conducted	Power Meter	Anritsu	ML2495A	1116010	09/27/2023	09/27/2024
Conducted	Power Sensor	Anritsu	MA2411B	34NKF50	09/27/2023	09/27/2024
Conducted	Temperature Chamber	KSON	THS-B4H100	2287	05/17/2023	05/17/2024
Conducted	DC Power supply	ABM	8185D	N/A	01/04/2023	01/04/2024
Conducted	AC Power supply	EXTECH	CFC105W	NA	N/A	N/A

6.4. Measurement Equipment Used:

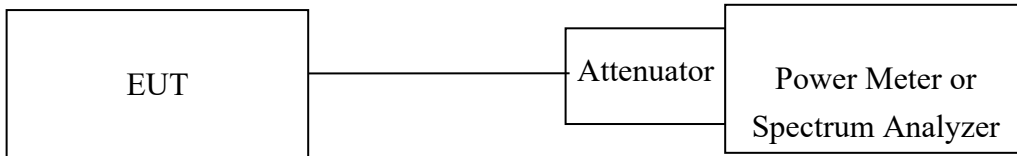

6.5. Measurement Result

According to §15.407(a)

(iv) For client devices in the 5.15-5.25 GHz band, the maximum conducted output power over the frequency band of operation shall not exceed 250 mW provided the maximum antenna gain does not exceed 6 dBi.

Band	Mode	Freq. (MHz)	Output Power (dBm)				Duty Factor (dB)	Total Output Power (dBm)	Output Power Limit (dBm)
			Chain 0	Chain 1	Chain 2	Chain 3			
UNII-1	a	5180	7.85				0.114	7.964	23.979
		5200	7.79				0.114	7.904	23.979
		5240	7.71				0.114	7.824	23.979
	HT20	5180	8.72				0.134	8.854	23.979
		5200	8.82				0.134	8.954	23.979
		5240	8.86				0.134	8.994	23.979
	VHT20	5180	8.03				0.124	8.154	23.979
		5200	7.99				0.124	8.114	23.979
		5240	8				0.124	8.124	23.979

Power Spectral Density Measurement:

Band	Mode	Frequency (MHz)	PSD (dBm/MHz)				Duty Factor (dB)	Total PSD (dBm/MHz)	PSD Limit (dBm/MHz)
			Chain 0	Chain 1	Chain 2	Chain 3			
UNII-1	11a	5180	-2.643				0.114	-2.529	11.000
		5200	-2.632				0.114	-2.518	11.000
		5240	-2.962				0.114	-2.848	11.000
	HT20	5180	-2.257				0.134	-2.123	11.000
		5200	-1.565				0.134	-1.431	11.000
		5240	-1.977				0.134	-1.843	11.000
	VHT20	5180	-2.348				0.124	-2.224	11.000
		5200	-2.076				0.124	-1.952	11.000
		5240	-2.825				0.124	-2.701	11.000

Band UNII-1
802.11a
Power Spectral Density Data Plot (CH Low)

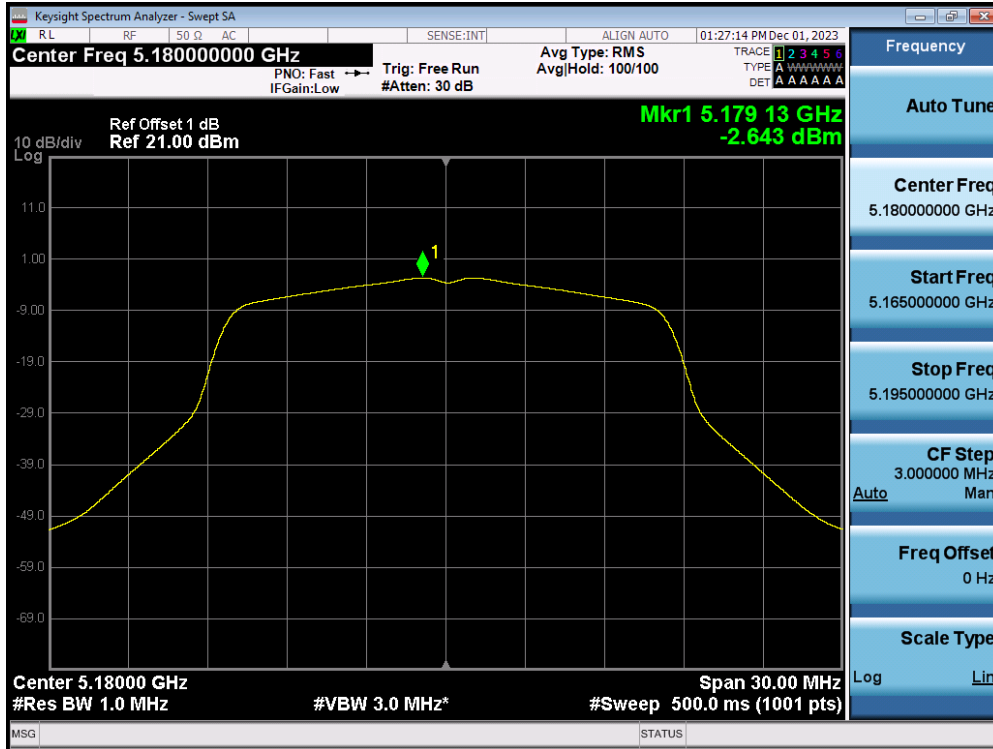

Power Spectral Density Data Plot (CH Mid)

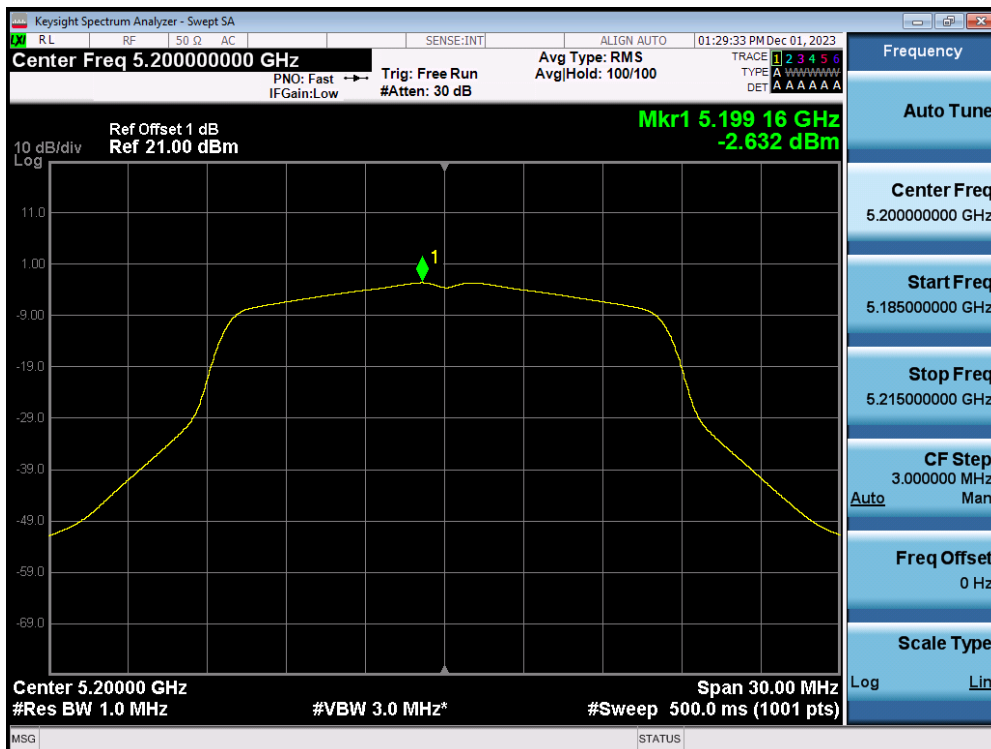

Power Spectral Density Data Plot (CH High)

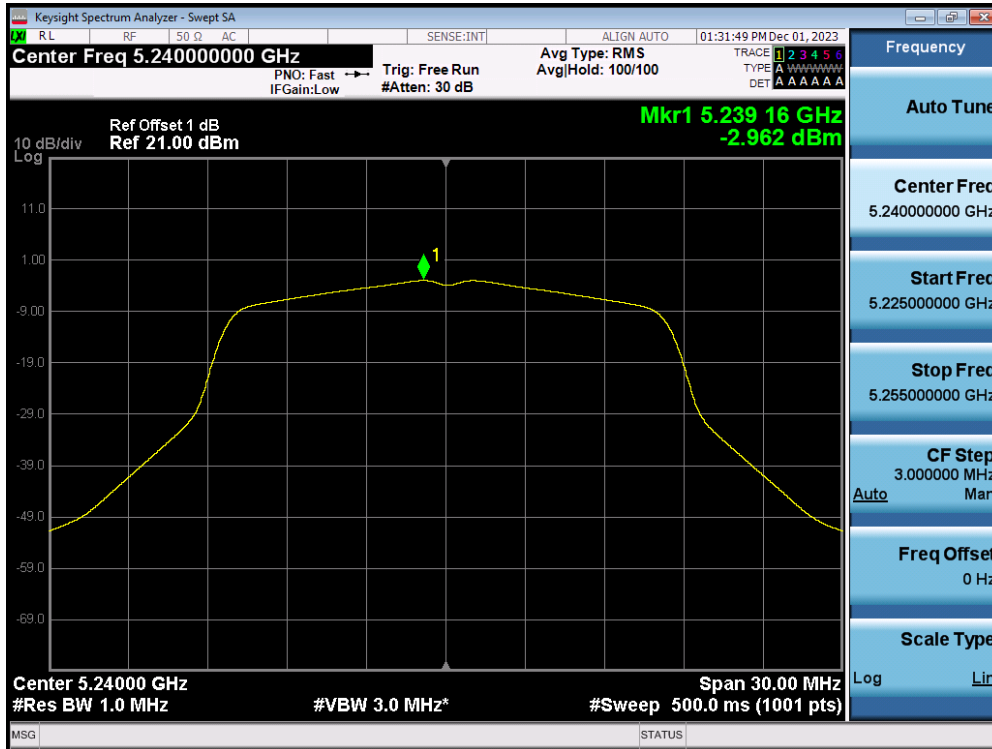

802.11n HT20, Power Spectral Density Test Plot (CH-Low)

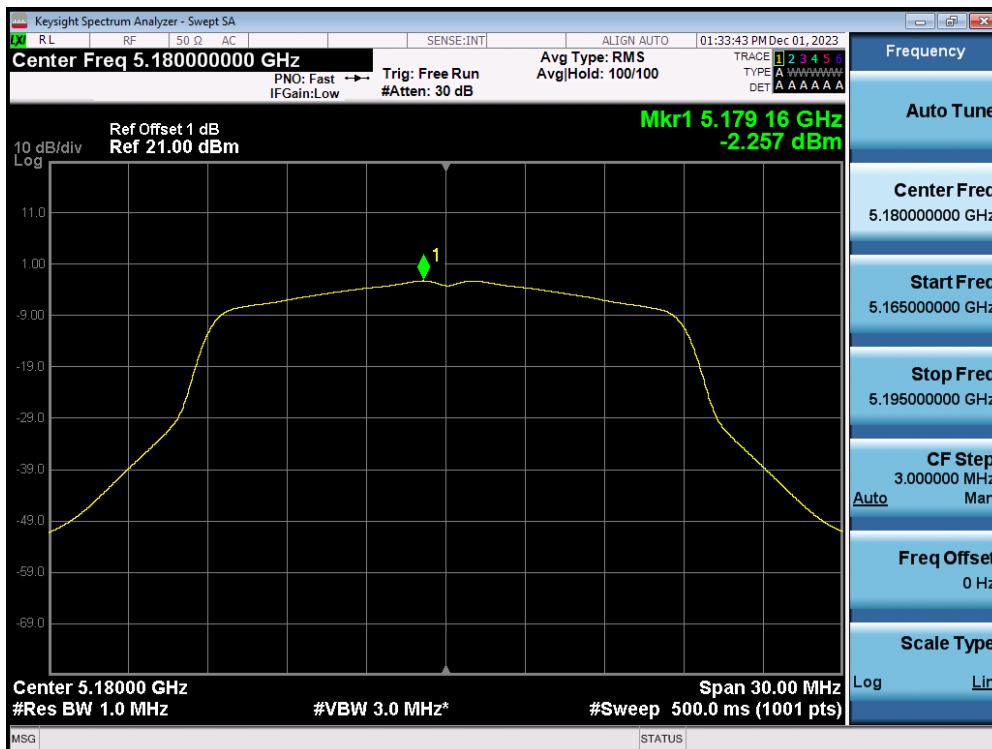

Power Spectral Density Test Plot (CH-Mid)

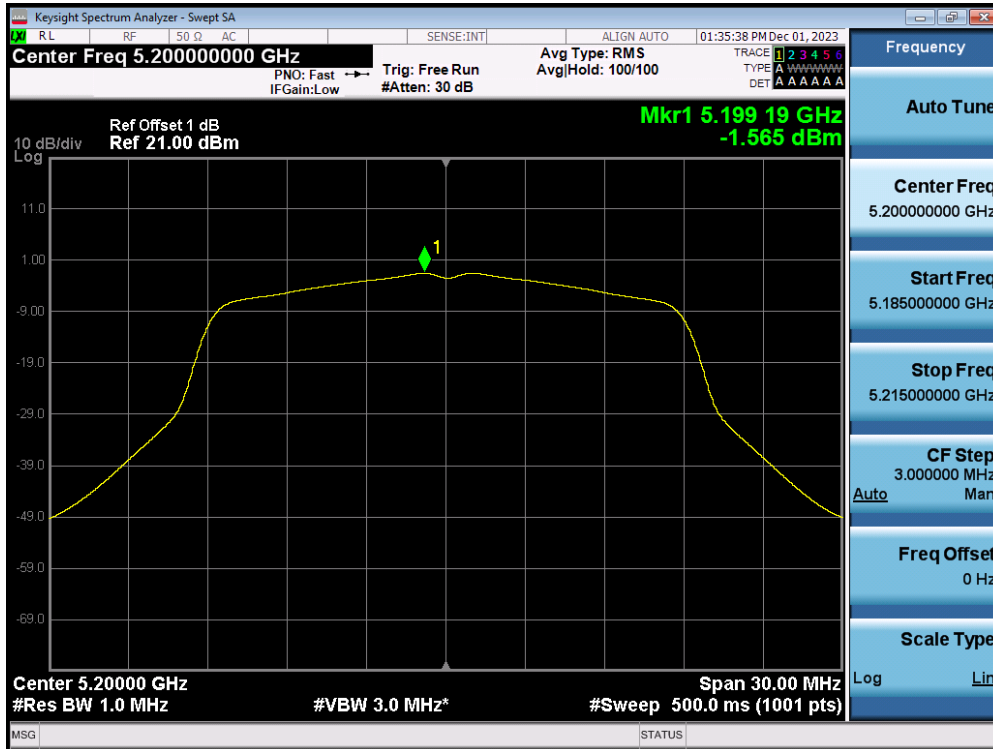

Power Spectral Density Test Plot (CH-High)

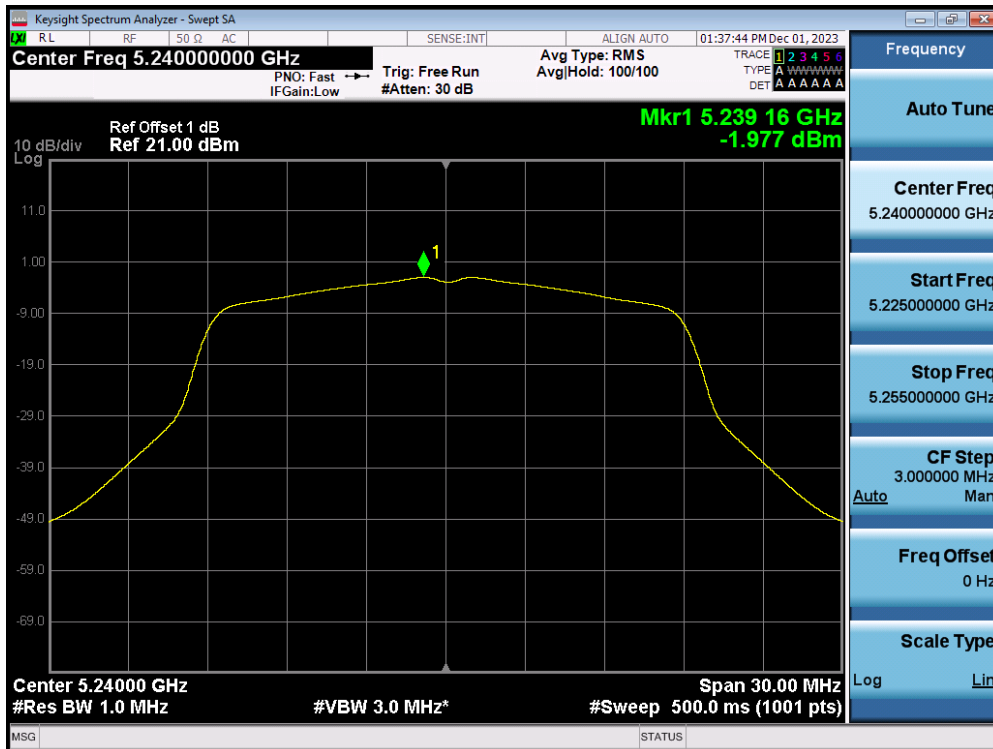

802.11ac VHT20, Power Spectral Density Test Plot (CH-Low)

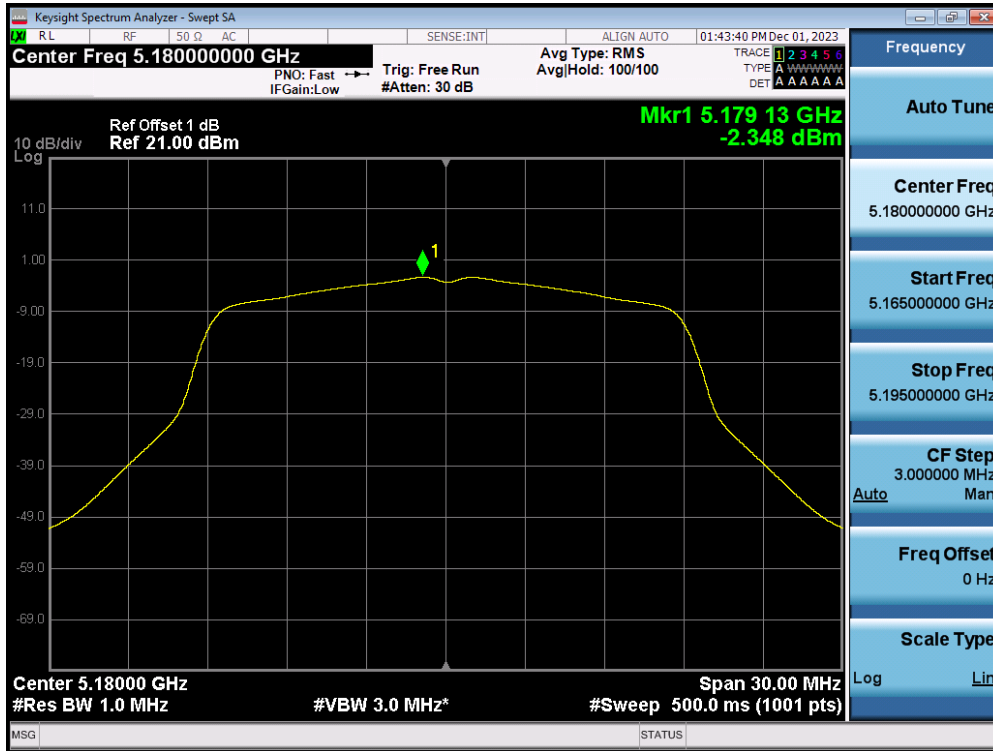

Power Spectral Density Test Plot (CH-Mid)

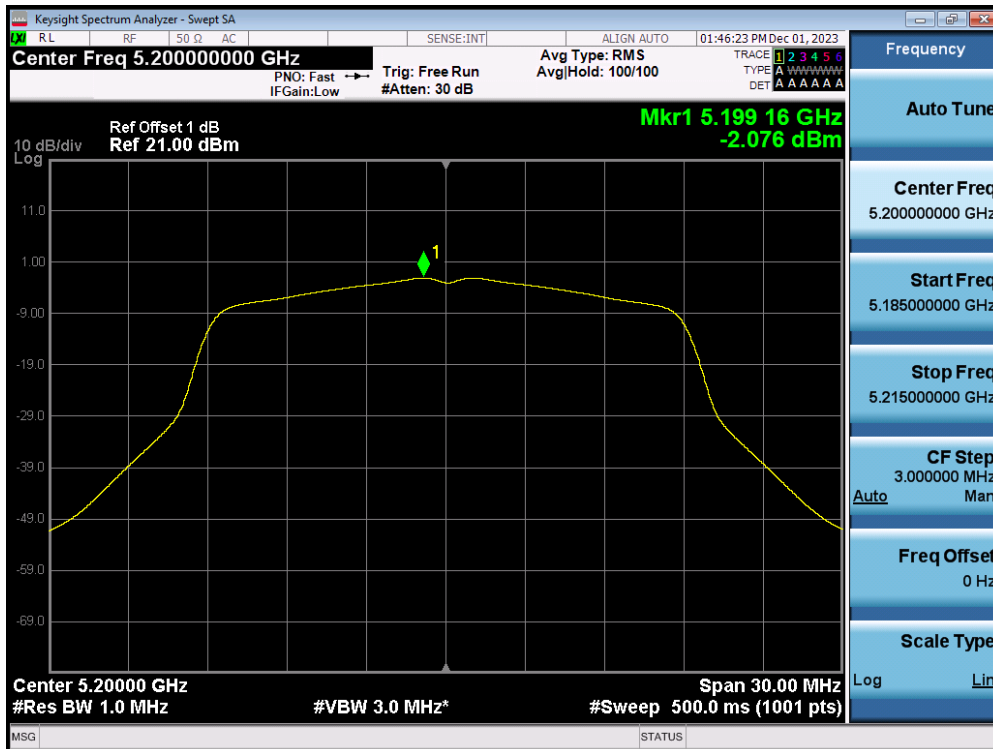

Power Spectral Density Test Plot (CH-High)

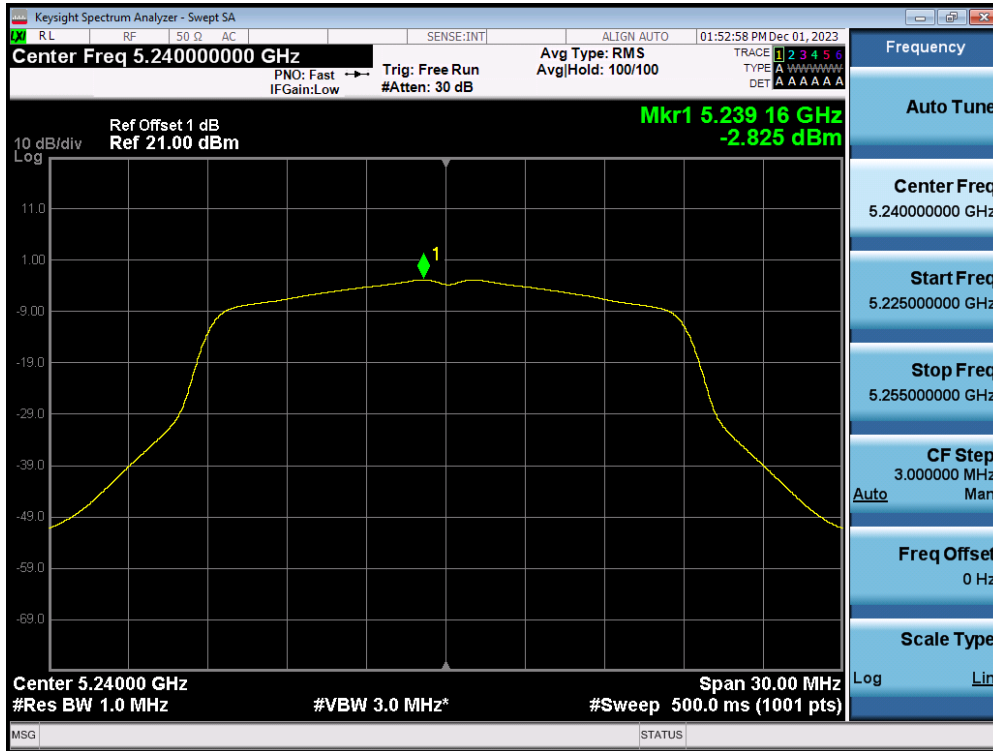

7. 26dB /99% Emission Bandwidth Measurement

7.1. Standard Applicable

According to §15.407(a) for band 1,2,3. No Limit required.

7.2. Measurement Procedure

1. Place the EUT on the table and set it in transmitting mode.
2. Remove the antenna from the EUT and then connect a low loss RF cable from the antenna port to the spectrum analyzer.
3. Set the spectrum analyzer as RBW=300kHz, VBW =1MHz, Span= 30MHz, Sweep=auto (OBW=15MHz~20MHz)
Set the spectrum analyzer as RBW=510kHz, VBW =1.6MHz, Span= 50MHz, Sweep=auto (OBW=35MHz~40MHz)
Set the spectrum analyzer as RBW=1MHz, VBW =3MHz, Span= 100MHz, Sweep=auto (OBW=72MHz~80MHz)
4. Mark the peak frequency and -26dB (upper and lower) frequency.
5. Repeat above procedures until all frequency measured were complete.

Refer to section D of KDB Document: KDB 789033 D02 General UNII Test Procedures

New Rules v01r03

7.3. Measurement Equipment Used:

Refer to section 6.3 for details.

7.4. Test Set-up:

Refer to section 6.4 for details.

7.5. Measurement Result

Band	Mode	Frequency (MHz)	26dB Bandwidth (MHz)	99% OBW (MHz)
UNII-1	11a	5180	20.099	16.38
		5200	20.075	16.358
		5240	20.174	16.373
	HT20	5180	20.917	17.499
		5200	21.037	17.501
		5240	20.853	17.499
	VHT20	5180	21.216	17.524
		5200	21.141	17.521
		5240	21.288	17.529

Band UNII-1

802.11a

26dB / 99% Band Width Test Data CH-Low

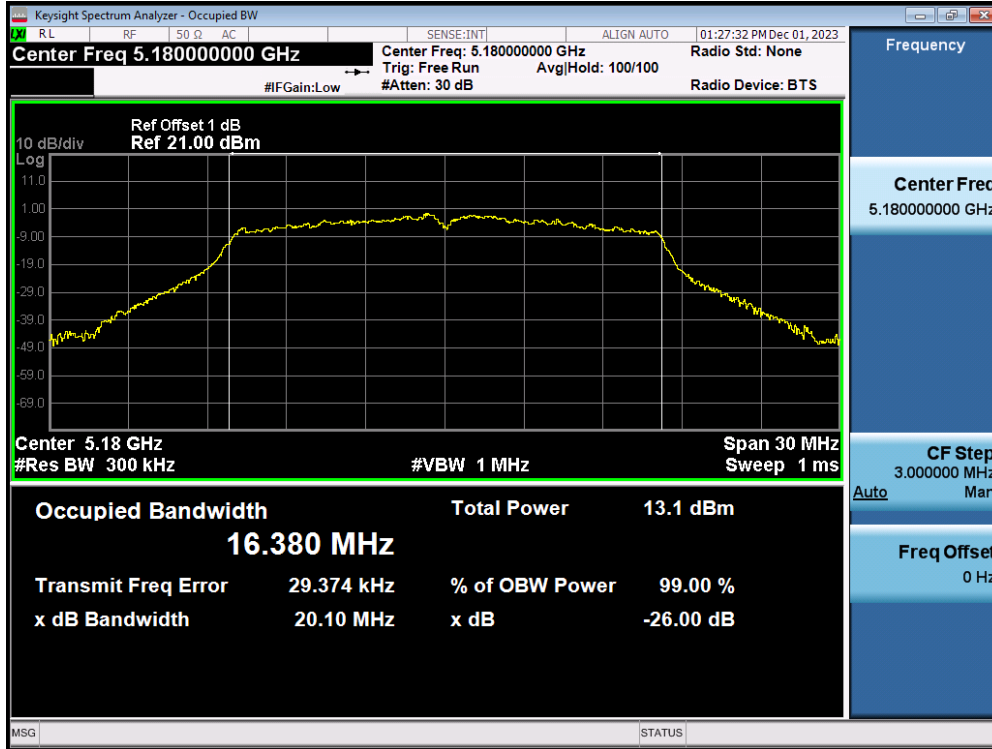

26dB / 99% Band Width Test Data CH-Mid

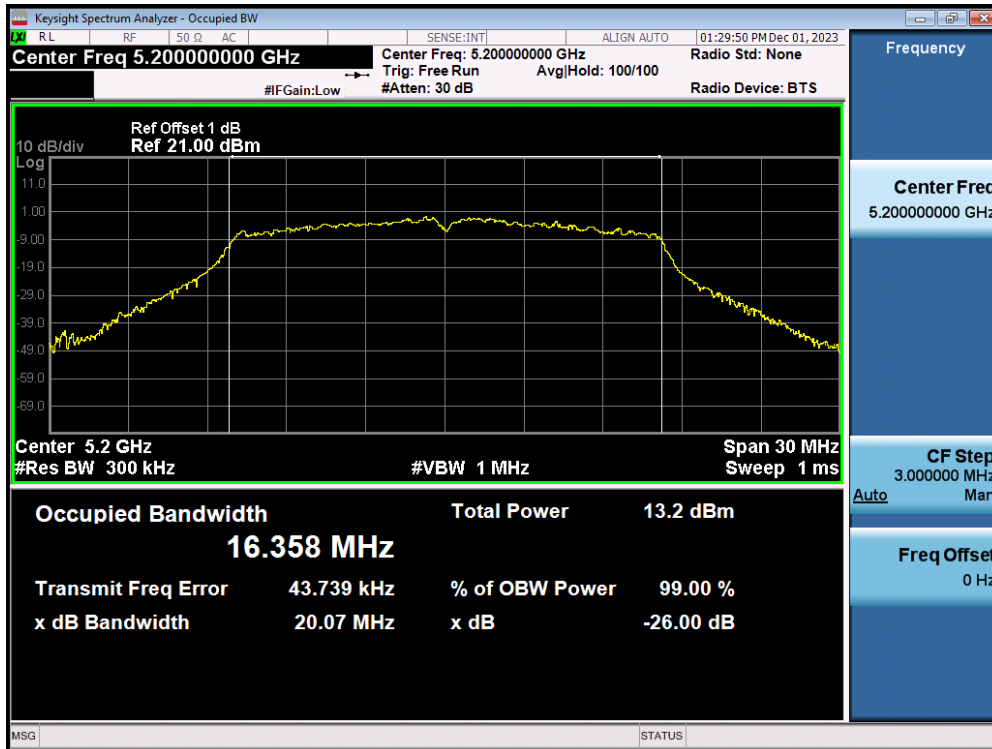

26dB / 99% Band Width Test Data CH-High

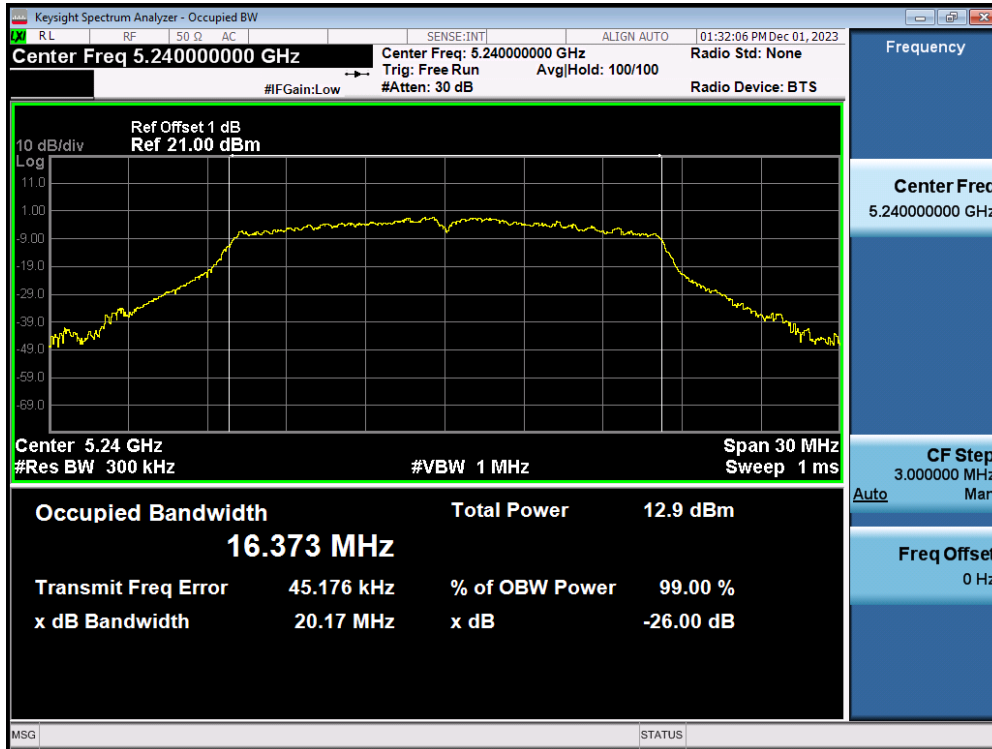

802.11n HT20

26dB / 99% Band Width Test Data CH-Low



26dB / 99% Band Width Test Data CH-Mid

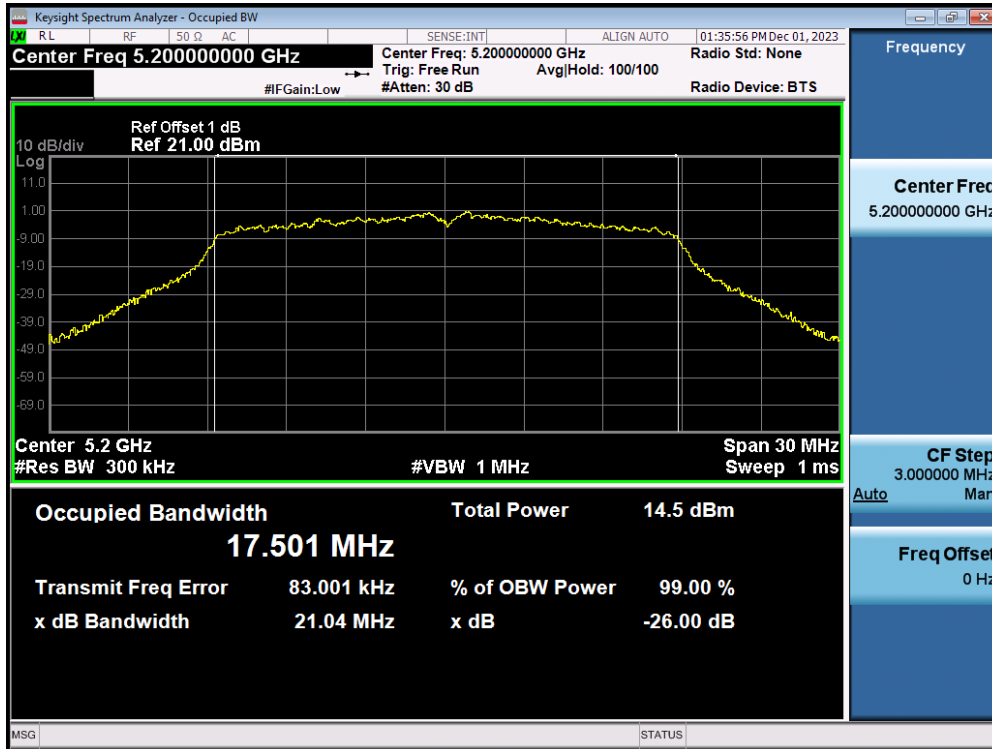

26dB / 99% Band Width Test Data CH-High

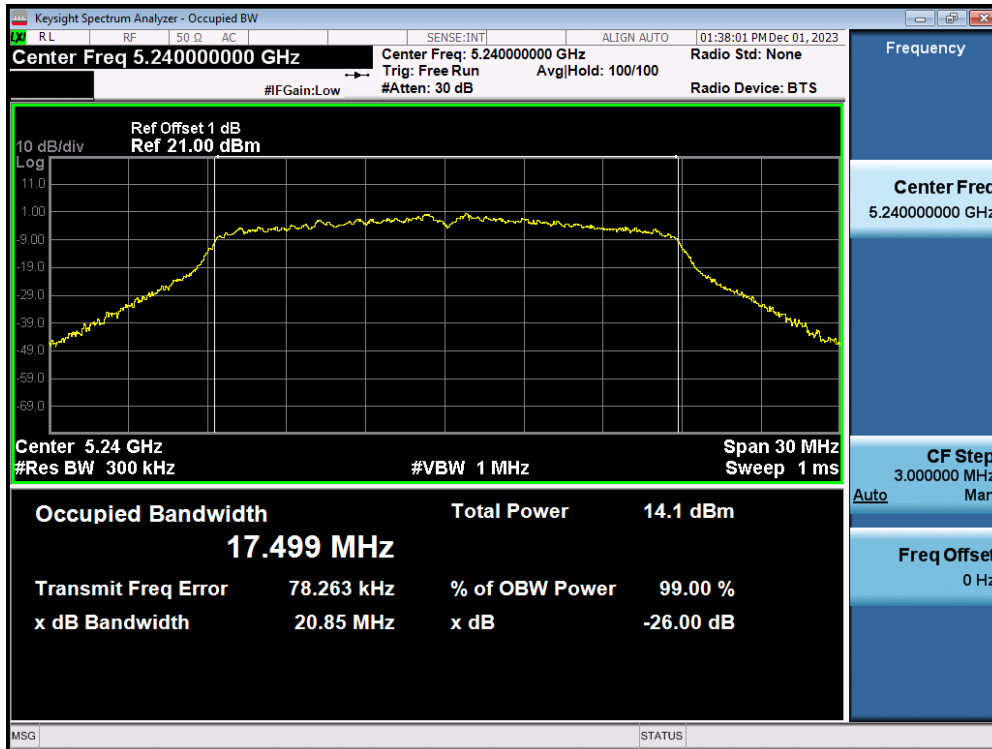

802.11ac VHT20

26dB / 99% Band Width Test Data CH-Low

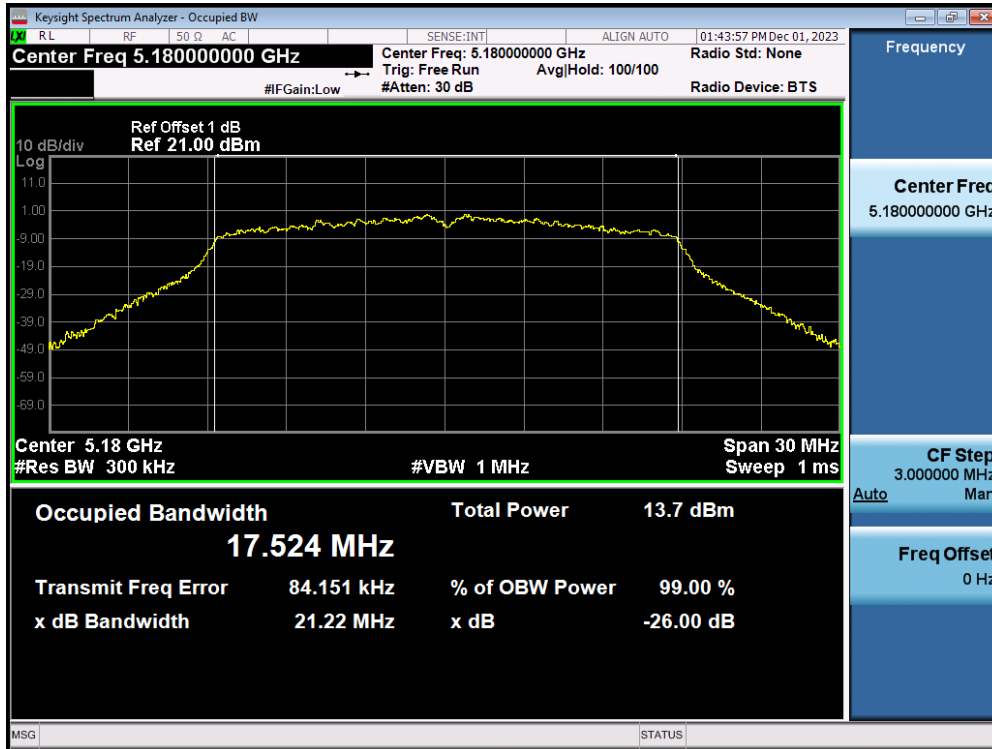

26dB / 99% Band Width Test Data CH-Mid

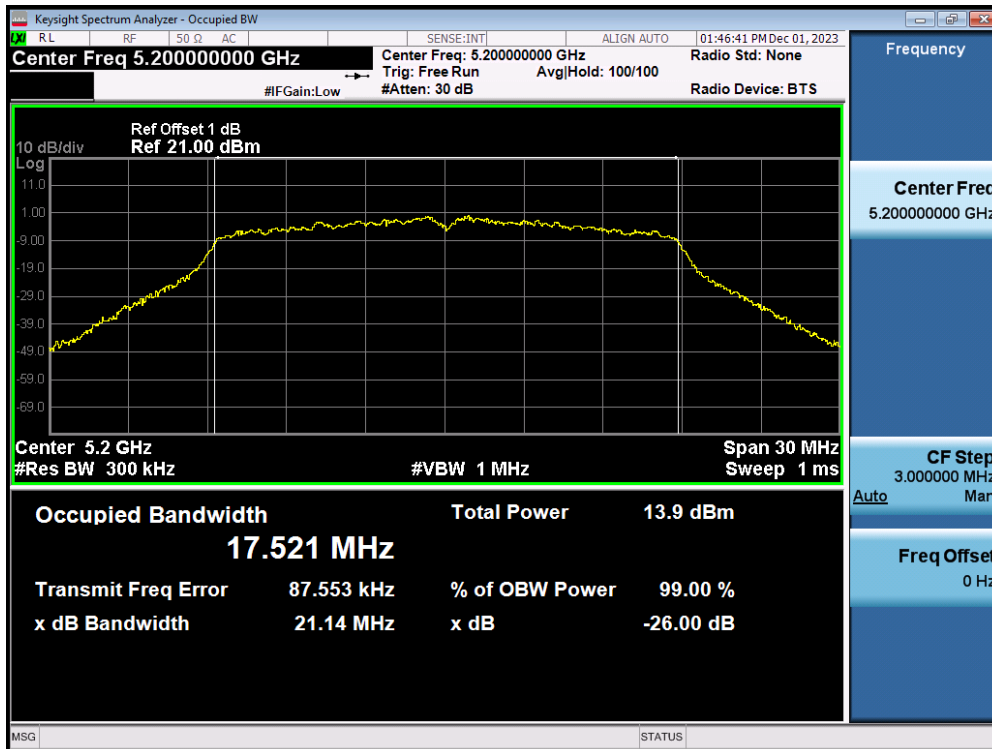

26dB / 99% Band Width Test Data CH-High



8. 6dB Emission Bandwidth Measurement

8.1. Standard Applicable

According to §15.407 (e) Within the 5.725-5.85 GHz band, the minimum 6 dB bandwidth of U-NII devices shall be at least 500 kHz.

8.2. Measurement Procedure

1. Place the EUT on the table and set it in transmitting mode.
2. Remove the antenna from the EUT and then connect a low loss RF cable from the antenna port to the spectrum analyzer.
3. Set the spectrum analyzer as RBW=100kHz, VBW =300MHz, Span= 50MHz, Sweep=auto
4. Mark the peak frequency and -6dB (upper and lower) frequency.
5. Repeat above procedures until all frequency measured were complete.

Refer to section D of KDB Document: KDB 789033 D02 General UNII Test Procedures New

Rules v01r03

8.3. Measurement Equipment Used:

Refer to section 6.3 for details.

8.4. Test Set-up:

Refer to section 6.4 for details.

8.5. Measurement Result

N/A.

9. Undesirable emission – Radiated Measurement

9.1. Standard Applicable

According to §15.407(b), Undesirable Emission Limits: Except as shown in Paragraph (b)(7) of this section, the peak emissions outside of the frequency bands of operation shall be attenuated in accordance with the following limits:

- (1) For transmitters operating in the 5.15-5.25 GHz band: all emissions outside of the 5.15-5.35 GHz band shall not exceed an e.i.r.p. of -27 dBm/MHz.
- (2) For transmitters operating in the 5.25-5.35 GHz band: all emissions outside of the 5.15-5.35 GHz band shall not exceed an e.i.r.p. of -27 dBm/MHz.
- (3) For transmitters operating in the 5.47-5.725 GHz band: all emissions outside of the 5.47-5.725 GHz band shall not exceed an e.i.r.p. of -27 dBm/MHz.
- (4) For transmitters operating in the 5.725-5.85 GHz band: all emissions within the frequency range from the band edge to 10 MHz above or below the band edge shall not exceed an e.i.r.p. of -17dBm/MHz; for frequencies 10 MHz or greater above or below the band edge, emissions shall not exceed an e.i.r.p. of -27 dBm/MHz.
- (5) The above emission measurements shall be performed using a minimum resolution bandwidth of 1 MHz. A lower resolution bandwidth may be employed near the band edge, when necessary, provided the measured energy is integrated to show the total power over 1 MHz.
- (6) Unwanted emissions below 1 GHz must comply with the general field strength limits set forth in Section 15.209. Further, any U-NII devices using an AC power line are required to comply also with the conducted limits set forth in Section 15.207.
- (7) The provisions of Section 15.205 of this part apply to intentional radiators operating under this section.
- (8) When measuring the emission limits, the nominal carrier frequency shall be adjusted as close to the upper and lower frequency band edges as the design of the equipment permits.

§15.205- RESTRICTED BANDS OF OPERATIONS

(a) Except as shown in paragraph (d) of this section, only spurious emissions are permitted in any of the frequency bands listed below:

MHz	MHz	MHz	GHz
0.090 - 0.110	16.42 - 16.423	399.9 - 410	4.5 - 5.15
¹ 0.495 - 0.505	16.69475 - 16.69525	608 - 614	5.35 - 5.46
2.1735 - 2.1905	16.80425 - 16.80475	960 - 1240	7.25 - 7.75
4.125 - 4.128	25.5 - 25.67	1300 - 1427	8.025 - 8.5
4.17725 - 4.17775	37.5 - 38.25	1435 - 1626.5	9.0 - 9.2
4.20725 - 4.20775	73 - 74.6	1645.5 - 1646.5	9.3 - 9.5
6.215 - 6.218	74.8 - 75.2	1660 - 1710	10.6 - 12.7
6.26775 - 6.26825	108 - 121.94	1718.8 - 1722.2	13.25 - 13.4
6.31175 - 6.31225	123 - 138	2200 - 2300	14.47 - 14.5
8.291 - 8.294	149.9 - 150.05	2310 - 2390	15.35 - 16.2
8.362 - 8.366	156.52475 -	2483.5 - 2500	17.7 - 21.4
8.37625 - 8.38675	156.52525	2655 - 2900	22.01 - 23.12
8.41425 - 8.41475	156.7 - 156.9	3260 - 3267	23.6 - 24.0
12.29 - 12.293	162.0125 - 167.17	3332 - 3339	31.2 - 31.8
12.51975 - 12.52025	167.72 - 173.2	3345.8 - 3358	36.43 - 36.5
12.57675 - 12.57725	240 - 285	3600 - 4400	(²)
13.36 - 13.41	322 - 335.4		

¹ Until February 1, 1999, this restricted band shall be 0.490-0.510 MHz.

² Above 38.6

(b) Except as provided in paragraphs (d) and (e), the field strength of emissions appearing within these frequency bands shall not exceed the limits shown in Section 15.209. At frequencies equal to or less than 1000 MHz, compliance with the limits in Section 15.209 shall be demonstrated using measurement instrumentation employing a CISPR quasi-peak detector. Above 1000 MHz, compliance with the emission limits in Section 15.209 shall be demonstrated based on the average value of the measured emissions. The provisions in Section 15.35 apply to these measurements.

§15.209- RADIATED EMISSION LIMITS: GENERAL REQUIREMENTS

FCC PART 15.209

MEASURING DISTANCE OF 3 METER		
FREQUENCY RANGE (MHz)	FIELD STRENGTH (Microvolts/m)	FIELD STRENGTH (dBuV/m)
30-88	100	40
88-216	150	43.5
216-960	200	46
Above 960	500	54

9.2. EUT Setup

1. The radiated emission tests were performed in the 3 meter open-test site, using the setup in accordance with the ANSI C63.10: 2013
2. The EUT was put in the front of the test table. The host PC system was placed on the center of the back edge on the test table. The peripherals like modem, monitor printer, K/B, and mouse were placed on the side of the host PC system. The rear of the EUT and peripherals were placed flushed with the rear of the tabletop.
3. The keyboard was placed directly in the front of the monitor, flushed with the front tabletop. The mouse was placed next to the Keyboard, flushed with the back of keyboard.
4. The spacing between the peripherals was 10 centimeters.
5. External I/O cables were draped along the edge of the test table and bundle when necessary.
6. The host PC system was connected with 120Vac/60Hz power source.

9.3. Measurement Procedure

1. The EUT was placed on a turn table which is 0.8m above ground plane.
2. The turn table shall rotate 360 degrees to determine the position of maximum emission level.
3. EUT is set 3m away from the receiving antenna which varied from 1m to 4m to find out the highest emissions.
4. Maximum procedure was performed on the six highest emissions to ensure EUT compliance.
5. And also, each emission was to be maximized by changing the polarization of receiving antenna both horizontal and vertical.
6. Repeat above procedures until all frequency measured were complete.

Refer to section F of KDB Document: KDB 789033 D02 General U-NII Test Procedures

New Rules v02r01

9.4. Test SET-UP (Block Diagram of Configuration)

(A) Radiated Emission Test Set-Up, Frequency Below 1000MHz

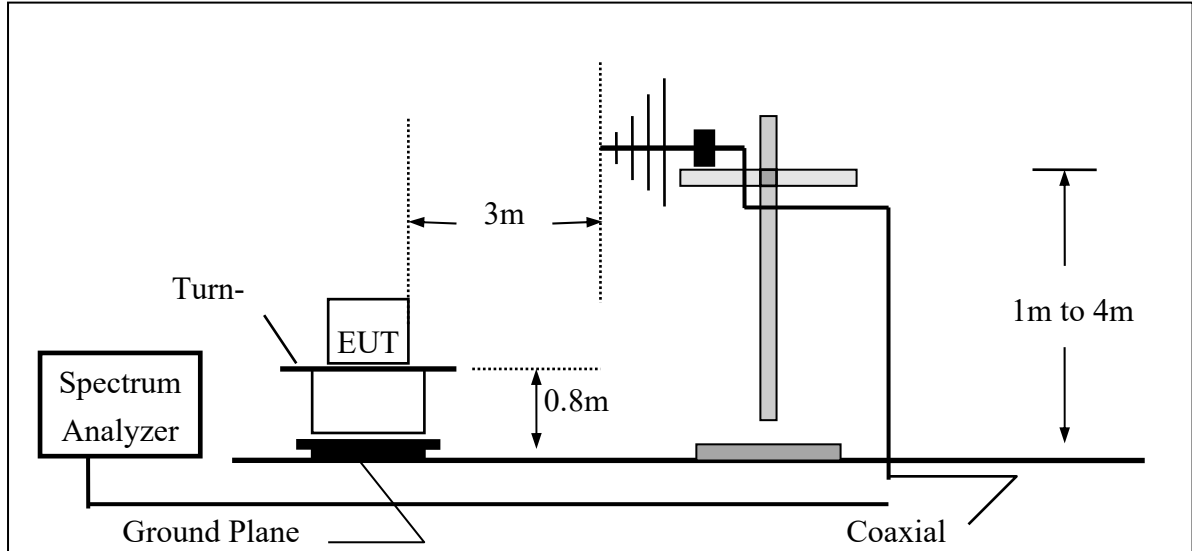

(B) Radiated Emission Test Set-UP Frequency Over 1 GHz

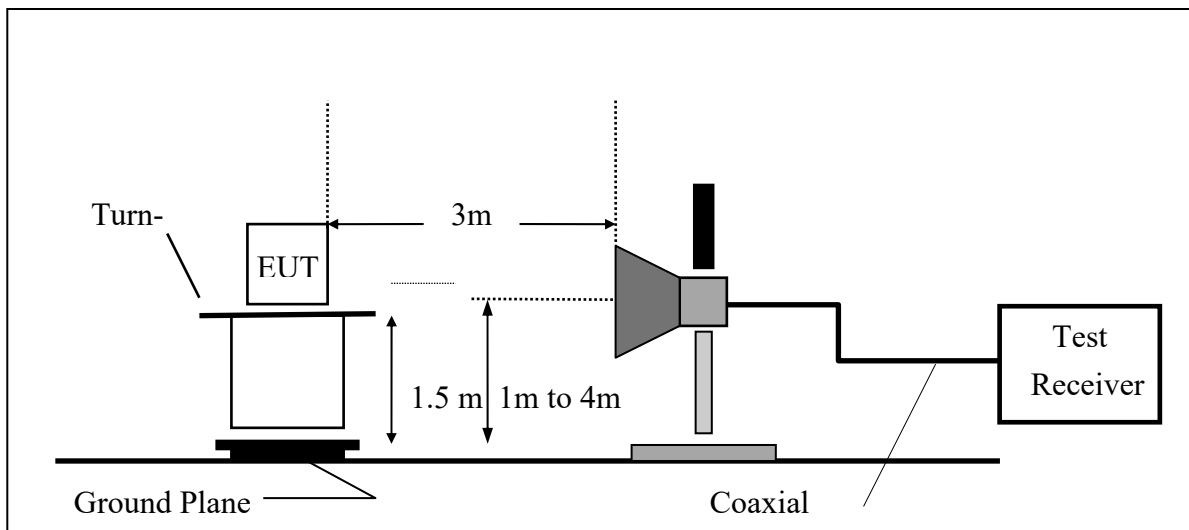

9.5. Measurement Equipment Used:

Location	Equipment Name	Brand	Model	S/N	Last Cal. Date	Next Cal. Date
Chamber 19	Signal analyzer	R&S	FSV40	101919	08/16/2023	08/16/2024
Chamber 19	EMI Receiver	R&S	ESR3	102461	05/08/2023	05/08/2024
Chamber 19	Loop Antenna	EM	EM-6879	271	10/02/2023	10/02/2024
Chamber 19	Bilog Antenna (30MHz-1GHz)	Schwarzbeck	VULB9168 w 6dB Att.	9168-736	03/08/2024	03/08/2025
Chamber 19	Horn antenna (1GHz-18GHz)	ETS • LINDGREN	3117	00218718	10/04/2023	10/04/2024
Chamber 19	Horn antenna (18GHz-26GHz)	Com-power	AH-826	081001	11/24/2023	11/24/2024
Chamber 19	Horn antenna (26GHz-40GHz)	Com-power	AH-640	100A	03/19/2024	03/19/2025
Chamber 19	Preamplifier (9kHz - 3GHz)	EM	EM330	060822	1/08/2024	1/08/2025
Chamber 19	Preamplifier (1GHz - 26GHz)	HP	8449B	3008A02471	10/25/2023	10/25/2024
Chamber 19	Preamplifier (26GHz-40GHz)	MITEQ	JS4-26004000- 27-5A	818471	05/04/2023	05/04/2024
Chamber 19	RF Cable (9kHz-26.5GHz)	Huber Suhner	SUCOFLEX 104A	MY1394/4A &MY1395/4 A	09/06/2023	09/06/2024
Chamber 19	RF Cable (18GHz-40GHz)	HUBER SU- HNER	Sucoflex 102	27963/2&374 21/2	11/22/2023	11/22/2024
Chamber 19	MXG Vector Signal Generator	KEYSIGHT	N5182B	MY53052399	12/26/2023	12/26/2024
Chamber 19	Test Software	Audix	E3 Ver:6.120203b	N/A	N/A	N/A

9.6. Field Strength Calculation

The field strength is calculated by adding the Antenna Factor and Cable Factor and subtracting the Amplifier Gain and Duty Cycle Correction Factor (if any) from the measured reading. The basic equation with a sample calculation is as follows:

$$FS = RA + AF + CL - AG$$

Where	FS = Field Strength	CL = Cable Attenuation Factor (Cable Loss)
	RA = Reading Amplitude	AG = Amplifier Gain
	AF = Antenna Factor	

$$\text{Factor} = AF + CL - AG$$

9.7. Measurement Result

Refer to attach tabular data sheets.

NOTE:

The resolution bandwidth and video bandwidth of test receiver/spectrum analyzer is 100kHz for Peak detection (PK) and Quasi-peak detection (QP) at frequency below 1GHz. And RBW 1MHz for frequency above 1GHz.

Radiated Spurious Emission Measurement Result (below 30M)

International Standard Laboratory Corp.
Company Address: No.120, Lane 180, Hsin Ho Rd.
Lung-Tan Dist., Tao Yuan City 325, Taiwan

Date: 2024-04-03

Project Number. : 23LR0158 Temp.(°C)/RH(%) : 25/60
Test Mode : Wifi5G a mode Tx low ch Tested by : Bill Huang

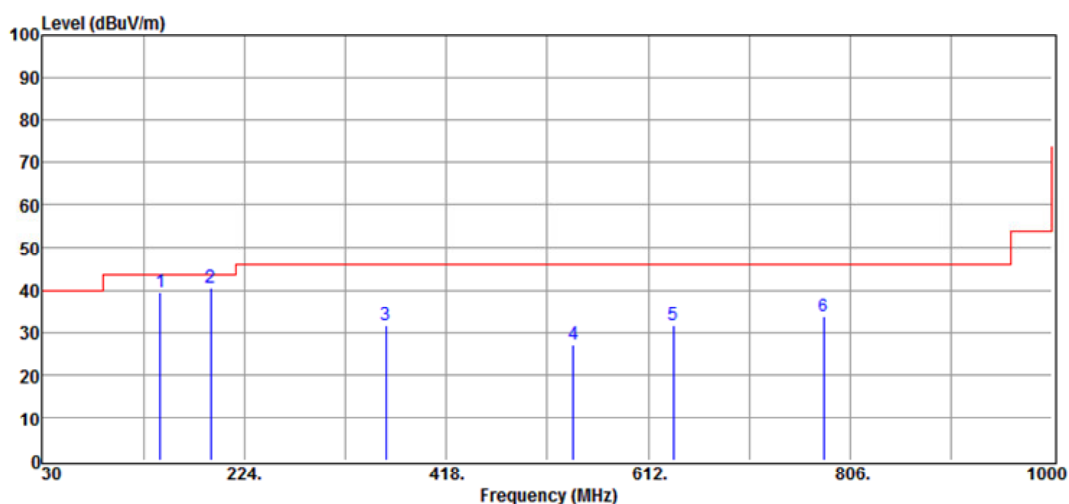

No	Freq MHz	Reading dBuV	Factor dB/m	Level dBuV/m	Limit dBuV/m	Margin dB	Remark	Pol V/H
1	143.49	48.43	-8.97	39.46	43.50	-4.04	Peak	VERTICAL
2	191.99	51.97	-11.41	40.56	43.50	-2.94	Peak	VERTICAL
3	359.80	37.98	-6.54	31.44	46.00	-14.56	Peak	VERTICAL
4	540.22	29.48	-2.42	27.06	46.00	-18.94	Peak	VERTICAL
5	636.25	31.71	0.02	31.73	46.00	-14.27	Peak	VERTICAL
6	780.78	31.10	2.42	33.52	46.00	-12.48	Peak	VERTICAL

International Standard Laboratory Corp.
Company Address: No.120, Lane 180, Hsin Ho Rd.
Lung-Tan Dist., Tao Yuan City 325, Taiwan
Date: 2024-04-03

Project Number. : 23LR0158 Temp.(°C)/RH(%) : 25/60
Test Mode : Wifi5G a mode Tx low ch Tested by : Bill Huang

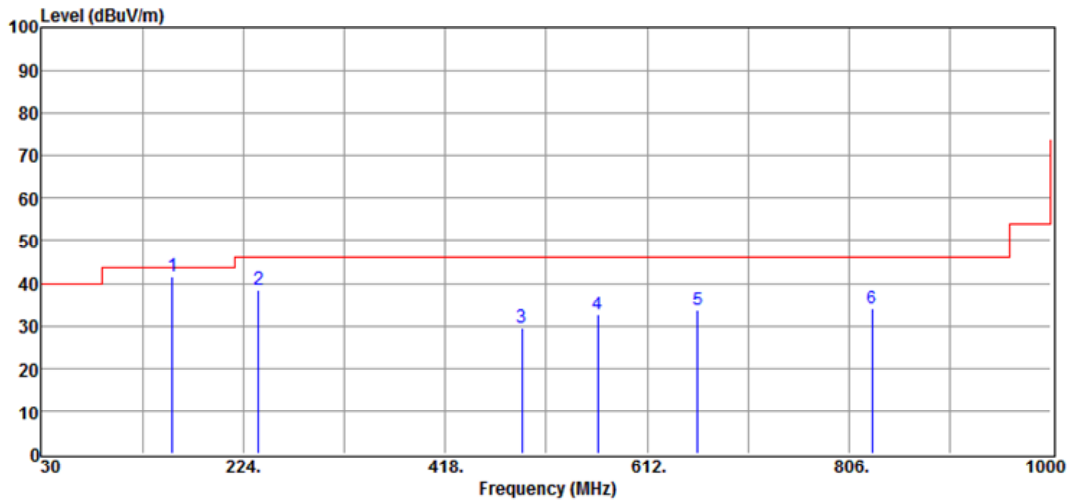

No	Freq MHz	Reading dBuV	Factor dB/m	Level dBuV/m	Limit dBuV/m	Margin dB	Remark	Pol V/H
1	156.10	50.03	-8.58	41.45	43.50	-2.05	Peak	HORIZONTAL
2	238.55	48.89	-10.38	38.51	46.00	-7.49	Peak	HORIZONTAL
3	491.72	32.77	-3.20	29.57	46.00	-16.43	Peak	HORIZONTAL
4	564.47	34.67	-1.86	32.81	46.00	-13.19	Peak	HORIZONTAL
5	660.50	33.48	0.11	33.59	46.00	-12.41	Peak	HORIZONTAL
6	828.31	31.34	2.78	34.12	46.00	-11.88	Peak	HORIZONTAL

International Standard Laboratory Corp.
Company Address: No.120, Lane 180, Hsin Ho Rd.
Lung-Tan Dist., Tao Yuan City 325, Taiwan

Date: 2024-04-03

Project Number. : 23LR0158 Temp.(°C)/RH(%) : 25/60
Test Mode : Wifi5G a mode Tx mid ch Tested by : Bill Huang

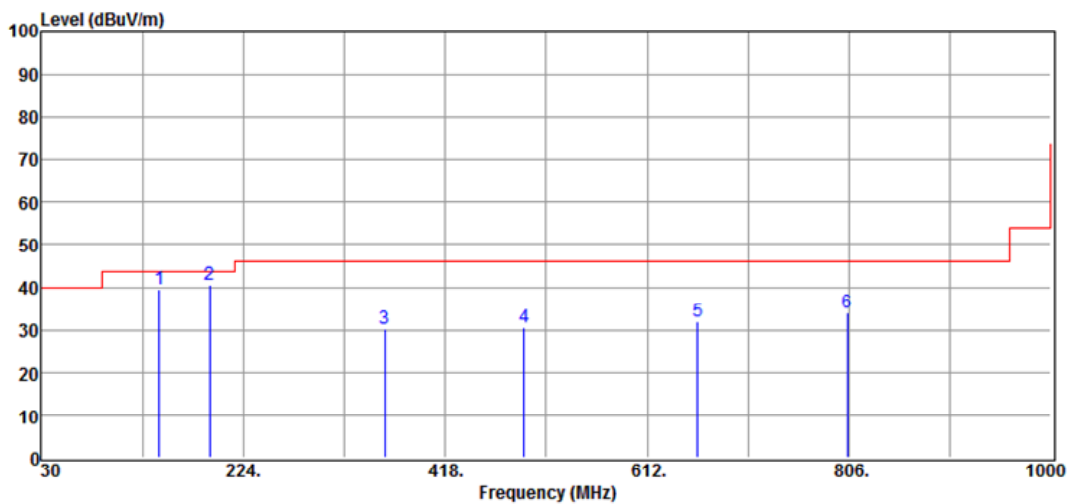

No	Freq MHz	Reading dBuV	Factor dB/m	Level dBuV/m	Limit dBuV/m	Margin dB	Remark	Pol V/H
1	143.49	48.61	-8.97	39.64	43.50	-3.86	Peak	VERTICAL
2	191.99	51.97	-11.41	40.56	43.50	-2.94	Peak	VERTICAL
3	359.80	36.66	-6.54	30.12	46.00	-15.88	Peak	VERTICAL
4	493.66	33.86	-3.19	30.67	46.00	-15.33	Peak	VERTICAL
5	660.50	31.90	0.11	32.01	46.00	-13.99	Peak	VERTICAL
6	804.06	31.31	2.61	33.92	46.00	-12.08	Peak	VERTICAL

International Standard Laboratory Corp.
Company Address: No.120, Lane 180, Hsin Ho Rd.
Lung-Tan Dist., Tao Yuan City 325, Taiwan

Date: 2024-04-03

Project Number. : 23LR0158 Temp.(°C)/RH(%) : 25/60

Test Mode : Wifi5G a mode Tx mid ch Tested by : Bill Huang

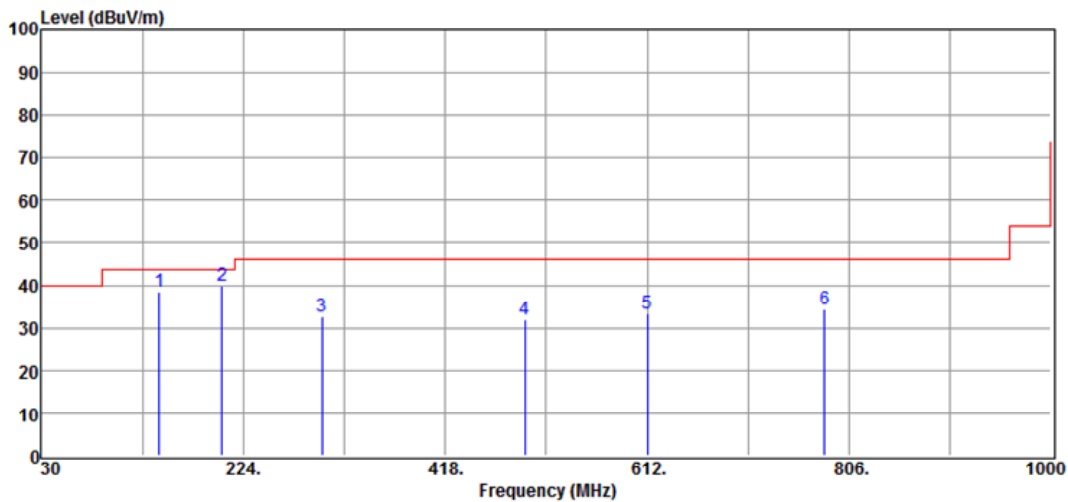

No	Freq MHz	Reading dBuV	Factor dB/m	Level dBuV/m	Limit dBuV/m	Margin dB	Remark	Pol V/H
1	143.49	47.60	-8.97	38.63	43.50	-4.87	Peak	HORIZONTAL
2	203.63	51.56	-11.78	39.78	43.50	-3.72	Peak	HORIZONTAL
3	299.66	40.70	-7.98	32.72	46.00	-13.28	Peak	HORIZONTAL
4	494.63	35.07	-3.18	31.89	46.00	-14.11	Peak	HORIZONTAL
5	612.00	33.64	-0.40	33.24	46.00	-12.76	Peak	HORIZONTAL
6	782.72	31.90	2.39	34.29	46.00	-11.71	Peak	HORIZONTAL

International Standard Laboratory Corp.
Company Address: No.120, Lane 180, Hsin Ho Rd.
Lung-Tan Dist., Tao Yuan City 325, Taiwan

Date: 2024-04-03

Project Number. : 23LR0158 Temp.(°C)/RH(%) : 25/60

Test Mode : Wifi5G a mode Tx high ch Tested by : Bill Huang

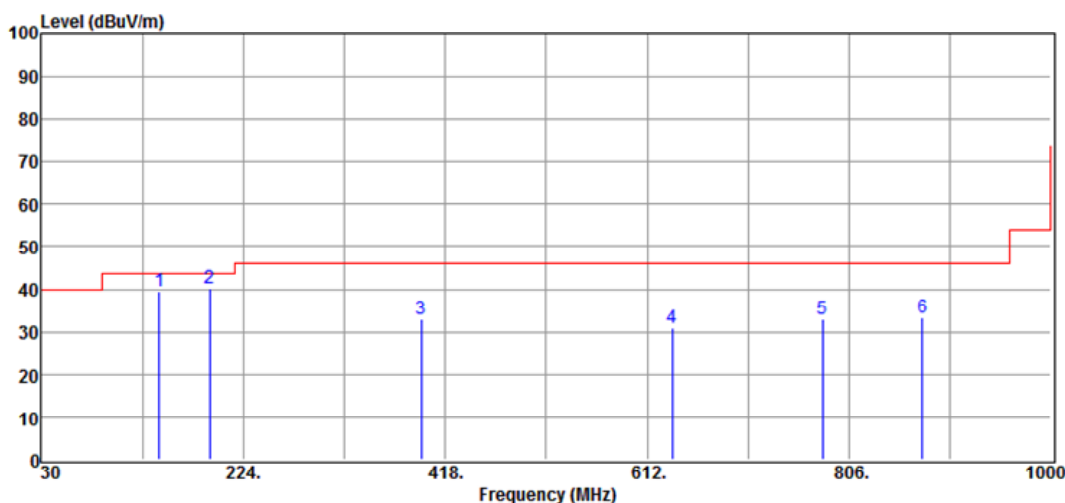

No	Freq MHz	Reading dBuV	Factor dB/m	Level dBuV/m	Limit dBuV/m	Margin dB	Remark	Pol V/H
1	143.49	48.59	-8.97	39.62	43.50	-3.88	Peak	VERTICAL
2	191.99	51.79	-11.41	40.38	43.50	-3.12	Peak	VERTICAL
3	394.72	38.29	-5.42	32.87	46.00	-13.13	Peak	VERTICAL
4	636.25	30.84	0.02	30.86	46.00	-15.14	Peak	VERTICAL
5	780.78	30.68	2.42	33.10	46.00	-12.90	Peak	VERTICAL
6	876.81	30.27	3.23	33.50	46.00	-12.50	Peak	VERTICAL

International Standard Laboratory Corp.
Company Address: No.120, Lane 180, Hsin Ho Rd.
Lung-Tan Dist., Tao Yuan City 325, Taiwan

Date: 2024-04-03

Project Number. : 23LR0158 Temp.(°C)/RH(%) : 25/60

Test Mode : Wifi5G a mode Tx high ch Tested by : Bill Huang

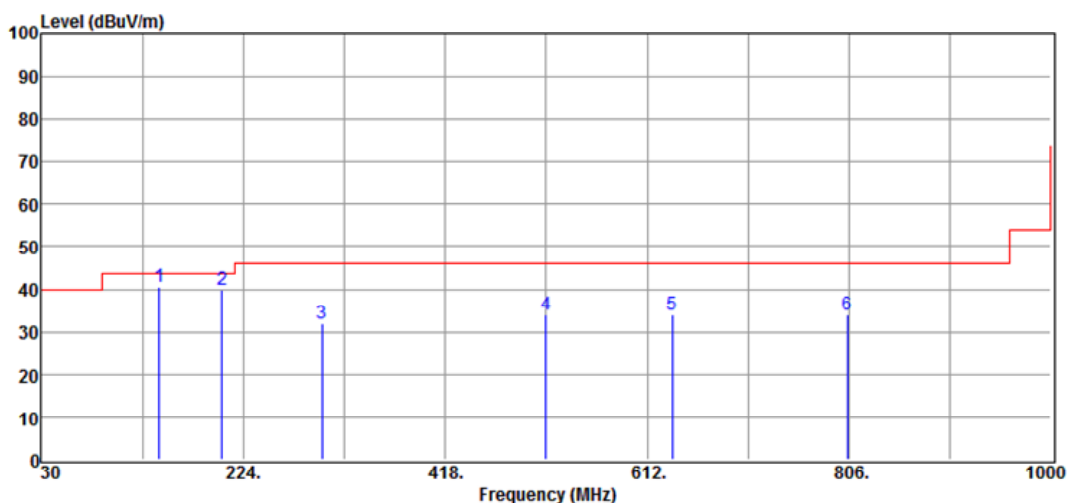

No	Freq MHz	Reading dBuV	Factor dB/m	Level dBuV/m	Limit dBuV/m	Margin dB	Remark	Pol V/H
1	143.49	49.61	-8.97	40.64	43.50	-2.86	Peak	HORIZONTAL
2	203.63	51.63	-11.78	39.85	43.50	-3.65	Peak	HORIZONTAL
3	299.66	40.00	-7.98	32.02	46.00	-13.98	Peak	HORIZONTAL
4	515.00	36.51	-2.62	33.89	46.00	-12.11	Peak	HORIZONTAL
5	636.25	34.02	0.02	34.04	46.00	-11.96	Peak	HORIZONTAL
6	804.06	31.44	2.61	34.05	46.00	-11.95	Peak	HORIZONTAL

International Standard Laboratory Corp.
Company Address: No.120, Lane 180, Hsin Ho Rd.
Lung-Tan Dist., Tao Yuan City 325, Taiwan

Date: 2023-12-06

Project Number. : 23LR0158 Temp.(°C)/RH(%) : 25/60

Test Mode : Wifi5G HT20 mode Tx low ch Tested by : Bill Huang

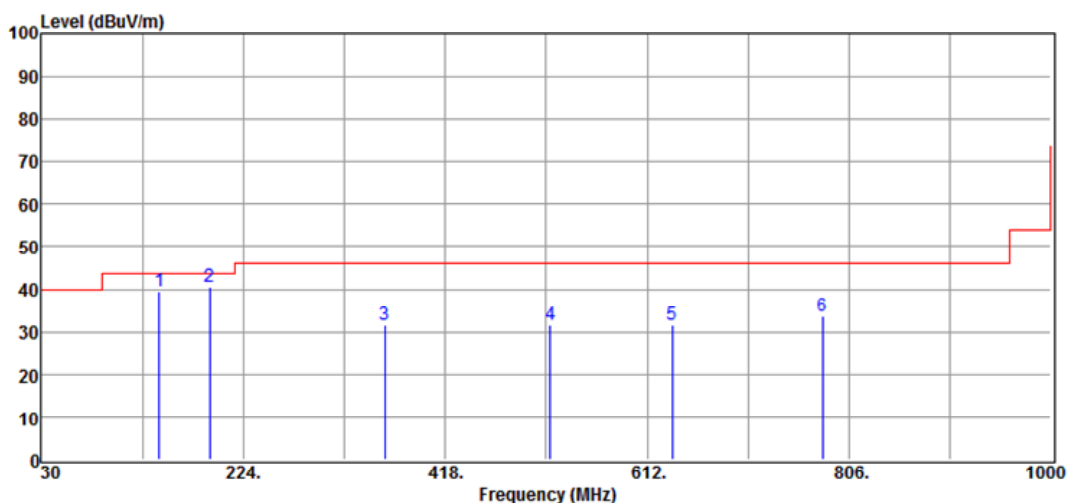

No	Freq MHz	Reading dBuV	Factor dB/m	Level dBuV/m	Limit dBuV/m	Margin dB	Remark	Pol V/H
1	143.49	49.72	-10.26	39.46	43.50	-4.04	Peak	VERTICAL
2	191.99	53.50	-12.94	40.56	43.50	-2.94	Peak	VERTICAL
3	359.80	39.71	-8.27	31.44	46.00	-14.56	Peak	VERTICAL
4	518.88	35.40	-3.91	31.49	46.00	-14.51	Peak	VERTICAL
5	636.25	32.96	-1.23	31.73	46.00	-14.27	Peak	VERTICAL
6	780.78	32.52	1.00	33.52	46.00	-12.48	Peak	VERTICAL

International Standard Laboratory Corp.
Company Address: No.120, Lane 180, Hsin Ho Rd.
Lung-Tan Dist., Tao Yuan City 325, Taiwan

Date: 2023-12-06

Project Number. : 23LR0158 Temp.(°C)/RH(%) : 25/60

Test Mode : Wifi5G HT20 mode Tx low ch Tested by : Bill Huang

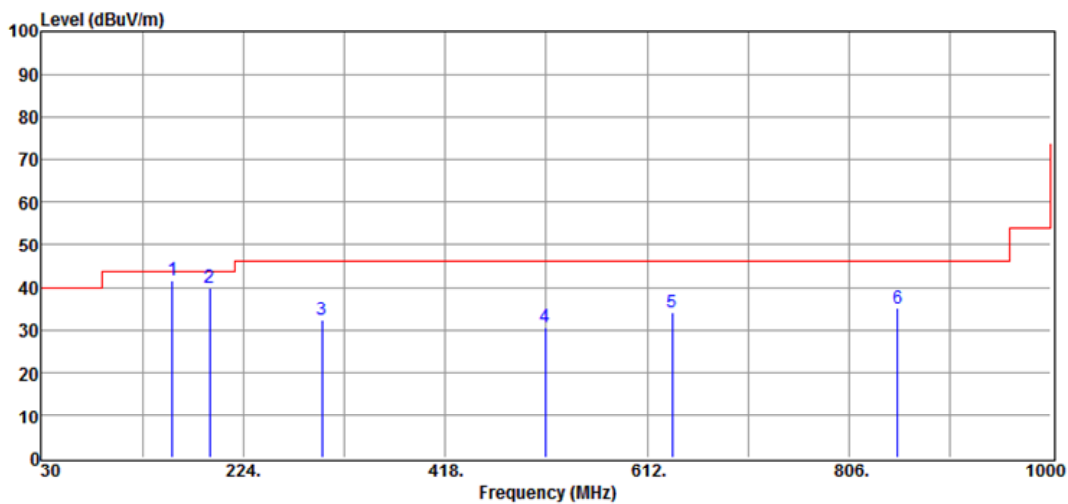

No	Freq MHz	Reading dBuV	Factor dB/m	Level dBuV/m	Limit dBuV/m	Margin dB	Remark	Pol V/H
1	156.10	51.66	-10.21	41.45	43.50	-2.05	Peak	HORIZONTAL
2	191.99	52.97	-12.94	40.03	43.50	-3.47	Peak	HORIZONTAL
3	299.66	41.64	-9.50	32.14	46.00	-13.86	Peak	HORIZONTAL
4	514.03	34.54	-4.01	30.53	46.00	-15.47	Peak	HORIZONTAL
5	636.25	35.21	-1.23	33.98	46.00	-12.02	Peak	HORIZONTAL
6	852.56	33.37	1.82	35.19	46.00	-10.81	Peak	HORIZONTAL

International Standard Laboratory Corp.
Company Address: No.120, Lane 180, Hsin Ho Rd.
Lung-Tan Dist., Tao Yuan City 325, Taiwan

Date: 2023-12-06

Project Number. : 23LR0158 Temp.(°C)/RH(%) : 25/60

Test Mode : Wifi5G HT20 mode Tx mid ch Tested by : Bill Huang

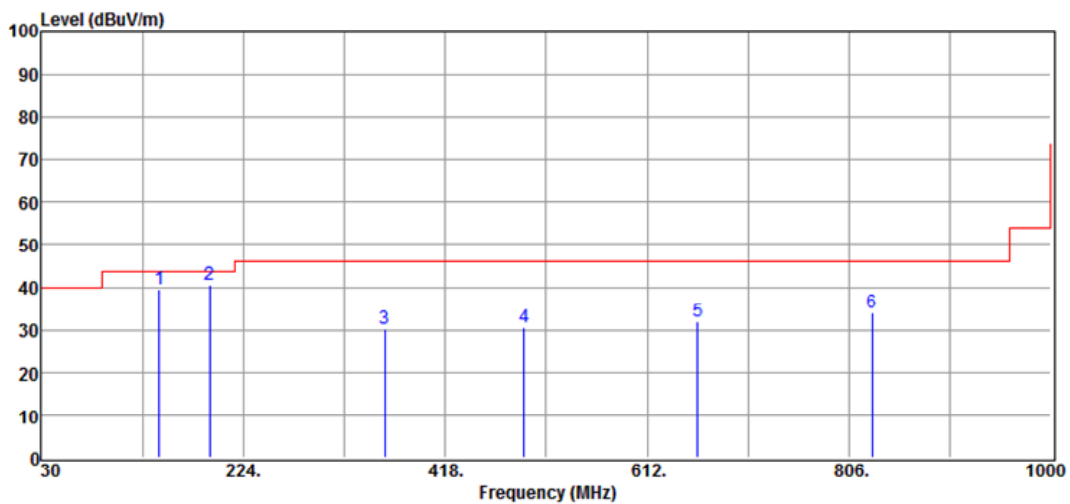

No	Freq MHz	Reading dBuV	Factor dB/m	Level dBuV/m	Limit dBuV/m	Margin dB	Remark	Pol V/H
1	143.49	49.90	-10.26	39.64	43.50	-3.86	Peak	VERTICAL
2	191.99	53.50	-12.94	40.56	43.50	-2.94	Peak	VERTICAL
3	359.80	38.39	-8.27	30.12	46.00	-15.88	Peak	VERTICAL
4	493.66	35.08	-4.41	30.67	46.00	-15.33	Peak	VERTICAL
5	660.50	32.99	-0.98	32.01	46.00	-13.99	Peak	VERTICAL
6	828.31	32.52	1.65	34.17	46.00	-11.83	Peak	VERTICAL

International Standard Laboratory Corp.
Company Address: No.120, Lane 180, Hsin Ho Rd.
Lung-Tan Dist., Tao Yuan City 325, Taiwan

Date: 2023-12-06

Project Number. : 23LR0158 Temp.(°C)/RH(%) : 25/60
Test Mode : Wifi5G HT20 mode Tx mid ch Tested by : Bill Huang

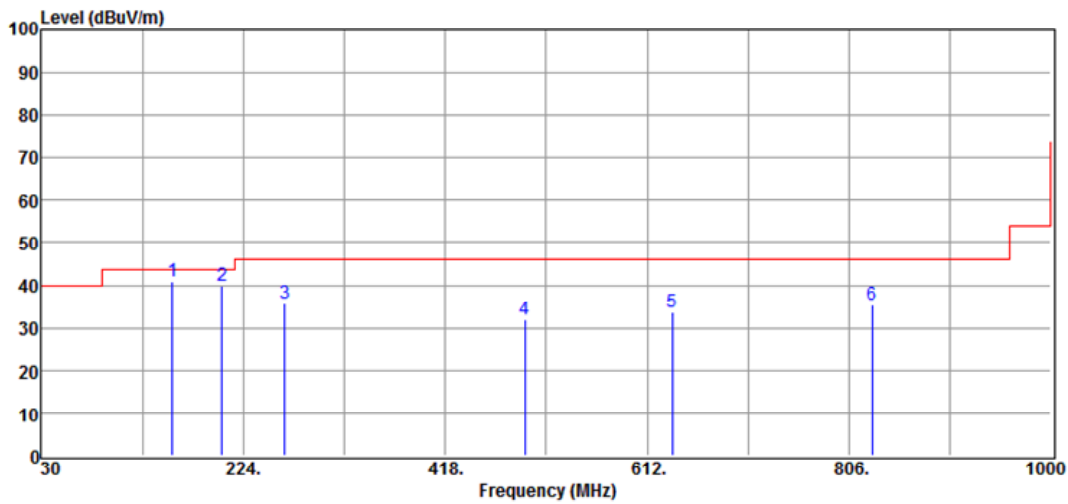

No	Freq MHz	Reading dBuV	Factor dB/m	Level dBuV/m	Limit dBuV/m	Margin dB	Remark	Pol V/H
1	156.10	51.12	-10.21	40.91	43.50	-2.59	Peak	HORIZONTAL
2	203.63	52.99	-13.21	39.78	43.50	-3.72	Peak	HORIZONTAL
3	263.77	46.23	-10.59	35.64	46.00	-10.36	Peak	HORIZONTAL
4	494.63	36.28	-4.39	31.89	46.00	-14.11	Peak	HORIZONTAL
5	636.25	34.96	-1.23	33.73	46.00	-12.27	Peak	HORIZONTAL
6	828.31	33.65	1.65	35.30	46.00	-10.70	Peak	HORIZONTAL

International Standard Laboratory Corp.
Company Address: No.120, Lane 180, Hsin Ho Rd.
Lung-Tan Dist., Tao Yuan City 325, Taiwan

Date: 2023-12-06

Project Number. : 23LR0158 Temp.(°C)/RH(%) : 25/60

Test Mode : Wifi5G HT20 mode Tx high ch Tested by : Bill Huang

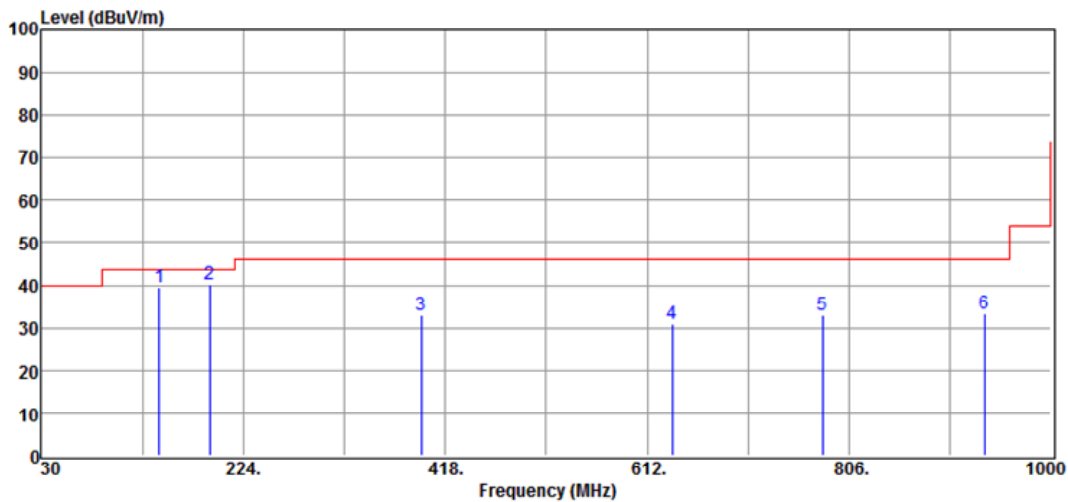

No	Freq MHz	Reading dBuV	Factor dB/m	Level dBuV/m	Limit dBuV/m	Margin dB	Remark	Pol V/H
1	143.49	49.88	-10.26	39.62	43.50	-3.88	Peak	VERTICAL
2	191.99	53.32	-12.94	40.38	43.50	-3.12	Peak	VERTICAL
3	394.72	39.72	-6.85	32.87	46.00	-13.13	Peak	VERTICAL
4	636.25	32.09	-1.23	30.86	46.00	-15.14	Peak	VERTICAL
5	780.78	32.10	1.00	33.10	46.00	-12.90	Peak	VERTICAL
6	935.98	29.88	3.45	33.33	46.00	-12.67	Peak	VERTICAL

International Standard Laboratory Corp.
Company Address: No.120, Lane 180, Hsin Ho Rd.
Lung-Tan Dist., Tao Yuan City 325, Taiwan

Date: 2023-12-06

Project Number. : 23LR0158 Temp.(°C)/RH(%) : 25/60
Test Mode : Wifi5G HT20 mode Tx high ch Tested by : Bill Huang

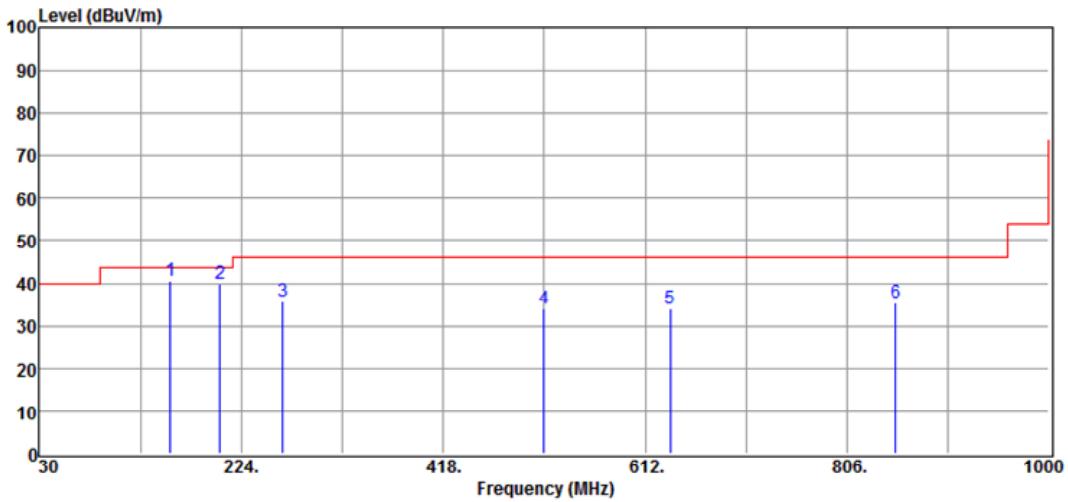

No	Freq MHz	Reading dBuV	Factor dB/m	Level dBuV/m	Limit dBuV/m	Margin dB	Remark	Pol V/H
1	156.10	50.85	-10.21	40.64	43.50	-2.86	Peak	HORIZONTAL
2	203.63	53.06	-13.21	39.85	43.50	-3.65	Peak	HORIZONTAL
3	263.77	46.42	-10.59	35.83	46.00	-10.17	Peak	HORIZONTAL
4	515.00	37.90	-4.01	33.89	46.00	-12.11	Peak	HORIZONTAL
5	636.25	35.27	-1.23	34.04	46.00	-11.96	Peak	HORIZONTAL
6	852.56	33.56	1.82	35.38	46.00	-10.62	Peak	HORIZONTAL

International Standard Laboratory Corp.
Company Address: No.120, Lane 180, Hsin Ho Rd.
Lung-Tan Dist., Tao Yuan City 325, Taiwan

Date: 2024-04-03

Project Number. : 23LR0158 Temp.(°C)/RH(%) : 25/60
Test Mode : Wifi5G VHT20 mode Tx low ch Tested by : Bill Huang

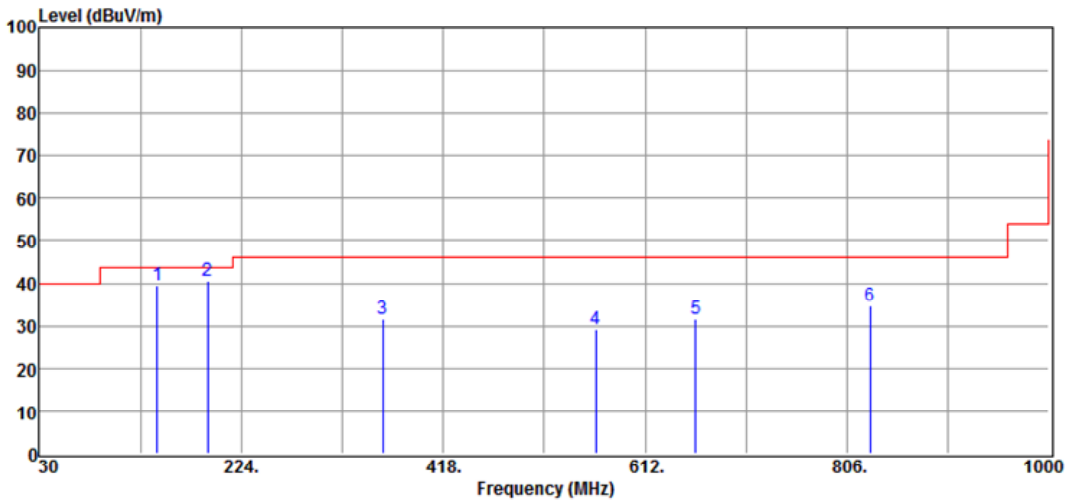

No	Freq MHz	Reading dBuV	Factor dB/m	Level dBuV/m	Limit dBuV/m	Margin dB	Remark	Pol V/H
1	143.49	48.43	-8.97	39.46	43.50	-4.04	Peak	VERTICAL
2	191.99	51.97	-11.41	40.56	43.50	-2.94	Peak	VERTICAL
3	359.80	37.98	-6.54	31.44	46.00	-14.56	Peak	VERTICAL
4	564.47	31.21	-1.86	29.35	46.00	-16.65	Peak	VERTICAL
5	660.50	31.40	0.11	31.51	46.00	-14.49	Peak	VERTICAL
6	828.31	31.78	2.78	34.56	46.00	-11.44	Peak	VERTICAL

International Standard Laboratory Corp.
Company Address: No.120, Lane 180, Hsin Ho Rd.
Lung-Tan Dist., Tao Yuan City 325, Taiwan
Date: 2024-04-03

Project Number. : 23LR0158 Temp.(°C)/RH(%) : 25/60
Test Mode : Wifi5G VHT20 mode Tx low ch Tested by : Bill Huang

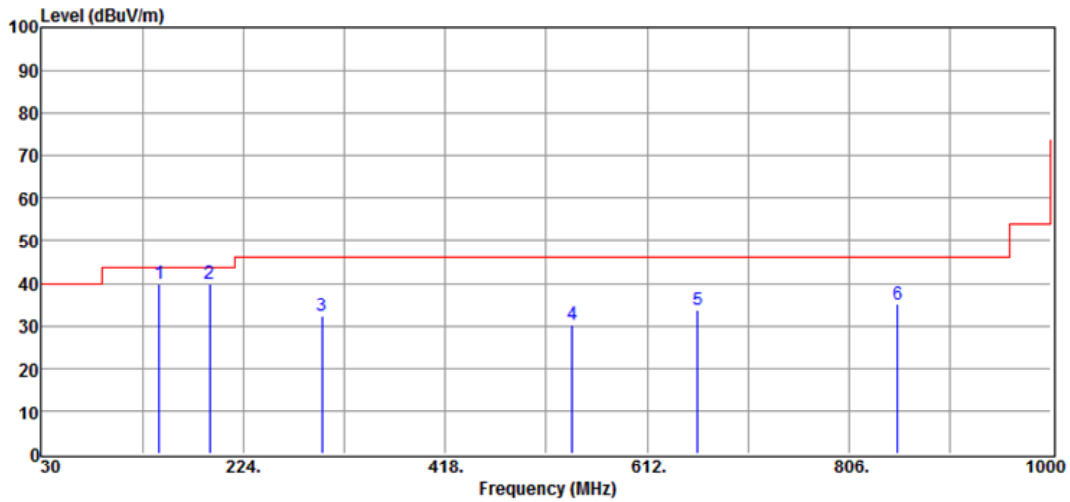

No	Freq MHz	Reading dBuV	Factor dB/m	Level dBuV/m	Limit dBuV/m	Margin dB	Remark	Pol V/H
1	143.49	48.68	-8.97	39.71	43.50	-3.79	Peak	HORIZONTAL
2	191.99	51.44	-11.41	40.03	43.50	-3.47	Peak	HORIZONTAL
3	299.66	40.12	-7.98	32.14	46.00	-13.86	Peak	HORIZONTAL
4	540.22	32.64	-2.42	30.22	46.00	-15.78	Peak	HORIZONTAL
5	660.50	33.48	0.11	33.59	46.00	-12.41	Peak	HORIZONTAL
6	852.56	31.83	3.36	35.19	46.00	-10.81	Peak	HORIZONTAL

International Standard Laboratory Corp.
Company Address: No.120, Lane 180, Hsin Ho Rd.
Lung-Tan Dist., Tao Yuan City 325, Taiwan

Date: 2024-04-03

Project Number. : 23LR0158 Temp.(°C)/RH(%) : 25/60
Test Mode : Wifi5G VHT20 mode Tx mid ch Tested by : Bill Huang

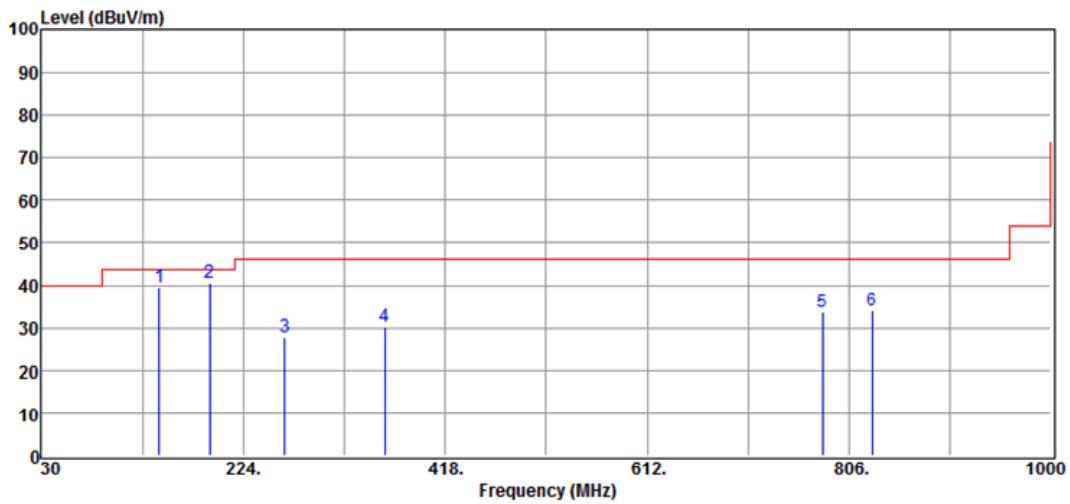

No	Freq MHz	Reading dBuV	Factor dB/m	Level dBuV/m	Limit dBuV/m	Margin dB	Remark	Pol V/H
1	143.49	48.61	-8.97	39.64	43.50	-3.86	Peak	VERTICAL
2	191.99	51.97	-11.41	40.56	43.50	-2.94	Peak	VERTICAL
3	263.77	37.28	-9.35	27.93	46.00	-18.07	Peak	VERTICAL
4	359.80	36.66	-6.54	30.12	46.00	-15.88	Peak	VERTICAL
5	780.78	31.20	2.42	33.62	46.00	-12.38	Peak	VERTICAL
6	828.31	31.39	2.78	34.17	46.00	-11.83	Peak	VERTICAL

International Standard Laboratory Corp.
Company Address: No.120, Lane 180, Hsin Ho Rd.
Lung-Tan Dist., Tao Yuan City 325, Taiwan
Date: 2024-04-03

Project Number. : 23LR0158 Temp.(°C)/RH(%) : 25/60
Test Mode : Wifi5G VHT20 mode Tx mid ch Tested by : Bill Huang

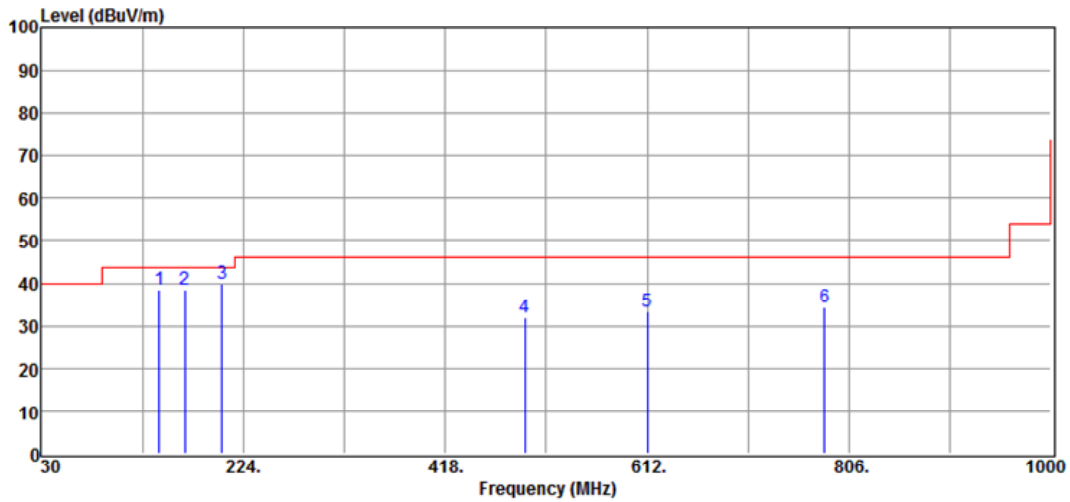

No	Freq MHz	Reading dBuV	Factor dB/m	Level dBuV/m	Limit dBuV/m	Margin dB	Remark	Pol V/H
1	143.49	47.60	-8.97	38.63	43.50	-4.87	Peak	HORIZONTAL
2	167.74	47.63	-8.98	38.65	43.50	-4.85	Peak	HORIZONTAL
3	203.63	51.56	-11.78	39.78	43.50	-3.72	Peak	HORIZONTAL
4	494.63	35.07	-3.18	31.89	46.00	-14.11	Peak	HORIZONTAL
5	612.00	33.64	-0.40	33.24	46.00	-12.76	Peak	HORIZONTAL
6	782.72	31.90	2.39	34.29	46.00	-11.71	Peak	HORIZONTAL

International Standard Laboratory Corp.
Company Address: No.120, Lane 180, Hsin Ho Rd.
Lung-Tan Dist., Tao Yuan City 325, Taiwan

Date: 2024-04-03

Project Number. : 23LR0158 Temp.(°C)/RH(%) : 25/60
Test Mode : Wifi5G VHT20 mode Tx high ch Tested by :
Bill Huang

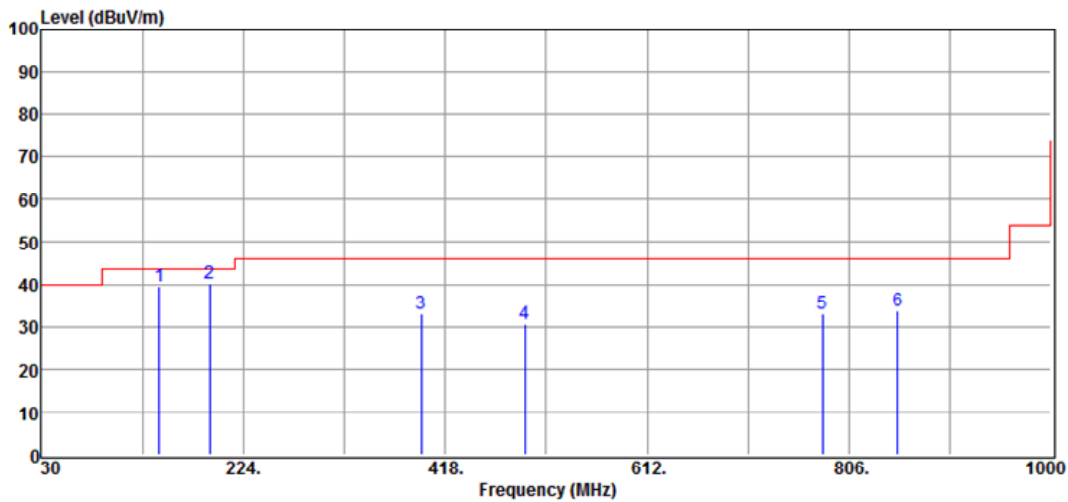

No	Freq MHz	Reading dBuV	Factor dB/m	Level dBuV/m	Limit dBuV/m	Margin dB	Remark	Pol V/H
1	143.49	48.59	-8.97	39.62	43.50	-3.88	Peak	VERTICAL
2	191.99	51.79	-11.41	40.38	43.50	-3.12	Peak	VERTICAL
3	394.72	38.29	-5.42	32.87	46.00	-13.13	Peak	VERTICAL
4	494.63	33.64	-3.18	30.46	46.00	-15.54	Peak	VERTICAL
5	780.78	30.68	2.42	33.10	46.00	-12.90	Peak	VERTICAL
6	852.56	30.28	3.36	33.64	46.00	-12.36	Peak	VERTICAL

International Standard Laboratory Corp.
Company Address: No.120, Lane 180, Hsin Ho Rd.
Lung-Tan Dist., Tao Yuan City 325, Taiwan

Date: 2024-04-03

Project Number. : 23LR0158 Temp.(°C)/RH(%) : 25/60
Test Mode : Wifi5G VHT20 mode Tx high ch Tested by :
Bill Huang

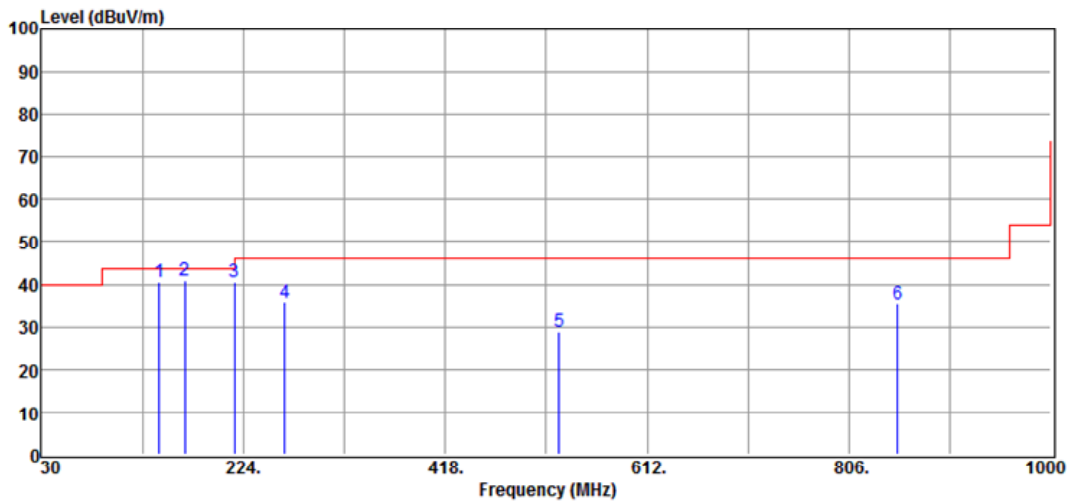

No	Freq MHz	Reading dBuV	Factor dB/m	Level dBuV/m	Limit dBuV/m	Margin dB	Remark	Pol V/H
1	143.49	49.61	-8.97	40.64	43.50	-2.86	Peak	HORIZONTAL
2	167.74	49.80	-8.98	40.82	43.50	-2.68	Peak	HORIZONTAL
3	215.27	52.40	-11.71	40.69	43.50	-2.81	Peak	HORIZONTAL
4	263.77	45.18	-9.35	35.83	46.00	-10.17	Peak	HORIZONTAL
5	527.61	31.33	-2.47	28.86	46.00	-17.14	Peak	HORIZONTAL
6	852.56	32.02	3.36	35.38	46.00	-10.62	Peak	HORIZONTAL

Radiated Spurious Emission Measurement Result (above 1GHz)

International Standard Laboratory Corp.
Company Address: No.120, Lane 180, Hsin Ho Rd.
Lung-Tan Dist., Tao Yuan City 325, Taiwan

Date: 2024-04-03

Project Number. : 23LR0158 Temp.(°C)/RH(%) : 25/60
Test Mode : Wifi5G a mode Tx low ch Tested by : Bill Huang

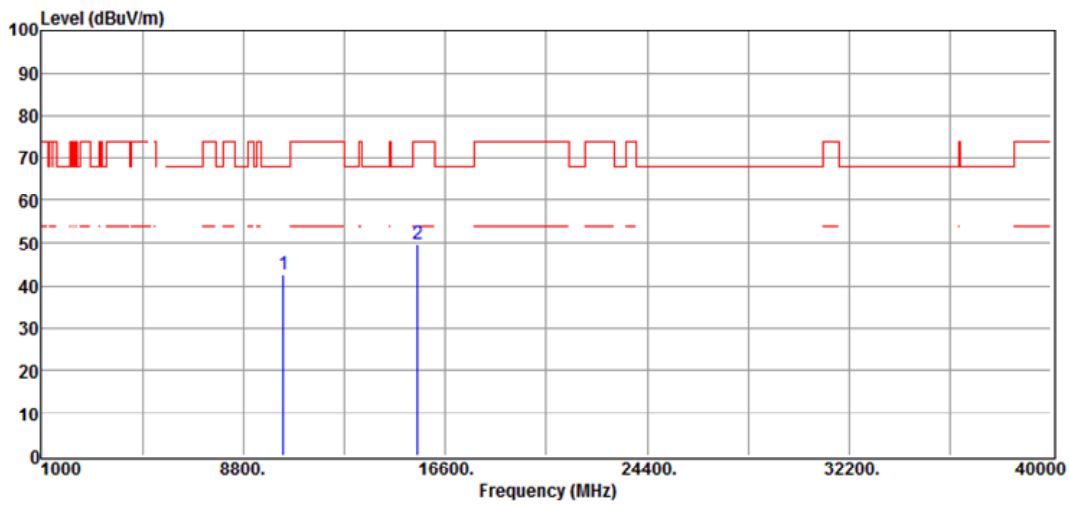

No	Freq MHz	Reading dBuV	Factor dB/m	Level dBuV/m	Limit dBuV/m	Margin dB	Remark	Pol V/H
1	10360.00	30.24	12.33	42.57	68.20	-25.63	Peak	VERTICAL
2	15540.00	31.78	18.17	49.95	74.00	-24.05	Peak	VERTICAL

International Standard Laboratory Corp.
Company Address: No.120, Lane 180, Hsin Ho Rd.
Lung-Tan Dist., Tao Yuan City 325, Taiwan

Date: 2024-04-03

Project Number. : 23LR0158 Temp.(°C)/RH(%) : 25/60

Test Mode : Wifi5G a mode Tx low ch Tested by : Bill Huang

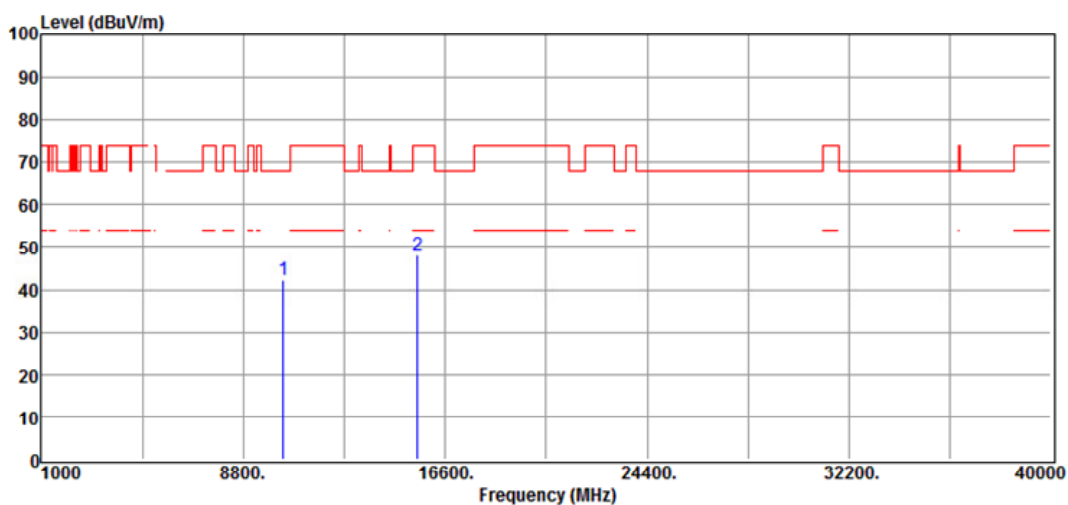

No	Freq MHz	Reading dBuV	Factor dB/m	Level dBuV/m	Limit dBuV/m	Margin dB	Remark	Pol V/H
1	10360.00	29.85	12.33	42.18	68.20	-26.02	Peak	HORIZONTAL
2	15540.00	29.88	18.17	48.05	74.00	-25.95	Peak	HORIZONTAL

International Standard Laboratory Corp.
Company Address: No.120, Lane 180, Hsin Ho Rd.
Lung-Tan Dist., Tao Yuan City 325, Taiwan

Date: 2024-04-03

Project Number. : 23LR0158 Temp.(°C)/RH(%) : 25/60
Test Mode : Wifi5G a mode Tx mid ch Tested by : Bill Huang

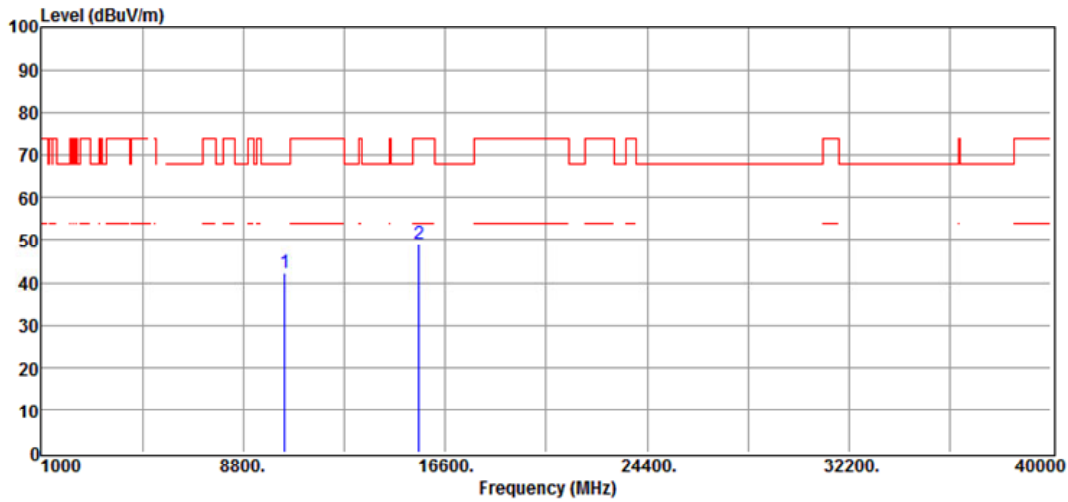

No	Freq MHz	Reading dBuV	Factor dB/m	Level dBuV/m	Limit dBuV/m	Margin dB	Remark	Pol V/H
1	10400.00	29.82	12.52	42.34	68.20	-25.86	Peak	VERTICAL
2	15600.00	30.85	18.31	49.16	74.00	-24.84	Peak	VERTICAL

International Standard Laboratory Corp.
Company Address: No.120, Lane 180, Hsin Ho Rd.
Lung-Tan Dist., Tao Yuan City 325, Taiwan

Date: 2024-04-03

Project Number. : 23LR0158 Temp.(°C)/RH(%) : 25/60
Test Mode : Wifi5G a mode Tx mid ch Tested by : Bill Huang

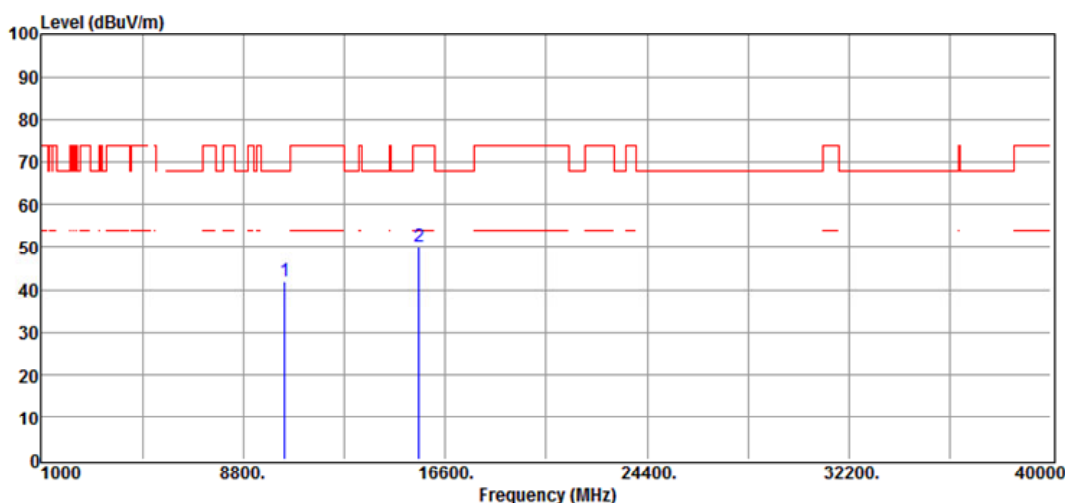

No	Freq MHz	Reading dBuV	Factor dB/m	Level dBuV/m	Limit dBuV/m	Margin dB	Remark	Pol V/H
1	10400.00	29.26	12.52	41.78	68.20	-26.42	Peak	HORIZONTAL
2	15600.00	31.87	18.31	50.18	74.00	-23.82	Peak	HORIZONTAL

International Standard Laboratory Corp.
Company Address: No.120, Lane 180, Hsin Ho Rd.
Lung-Tan Dist., Tao Yuan City 325, Taiwan

Date: 2024-04-03

Project Number. : 23LR0158 Temp.(°C)/RH(%) : 25/60
Test Mode : Wifi5G a mode Tx high ch Tested by : Bill Huang

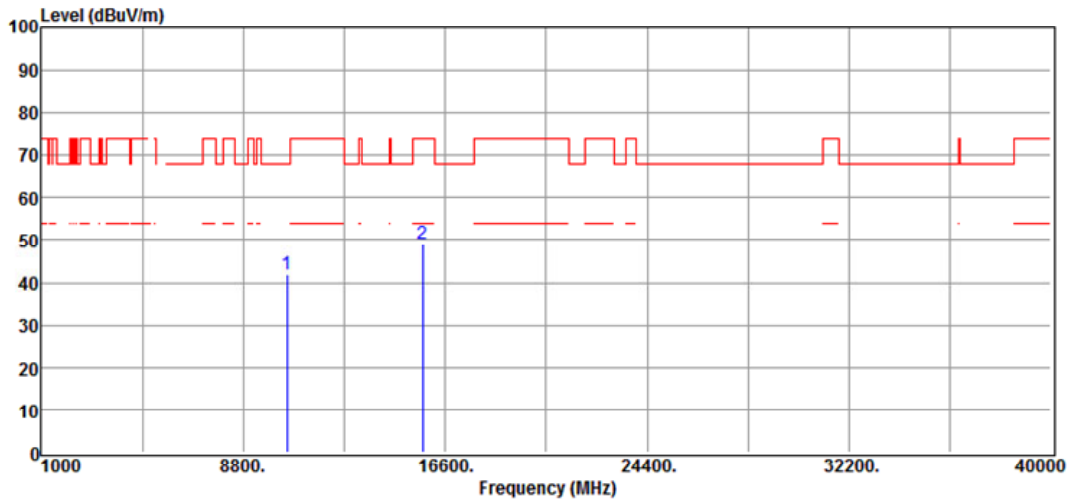

No	Freq MHz	Reading dBuV	Factor dB/m	Level dBuV/m	Limit dBuV/m	Margin dB	Remark	Pol V/H
1	10480.00	29.15	12.63	41.78	68.20	-26.42	Peak	VERTICAL
2	15720.00	30.90	18.16	49.06	74.00	-24.94	Peak	VERTICAL

International Standard Laboratory Corp.
Company Address: No.120, Lane 180, Hsin Ho Rd.
Lung-Tan Dist., Tao Yuan City 325, Taiwan

Date: 2024-04-03

Project Number. : 23LR0158 Temp.(°C)/RH(%) : 25/60
Test Mode : Wifi5G a mode Tx high ch Tested by : Bill Huang

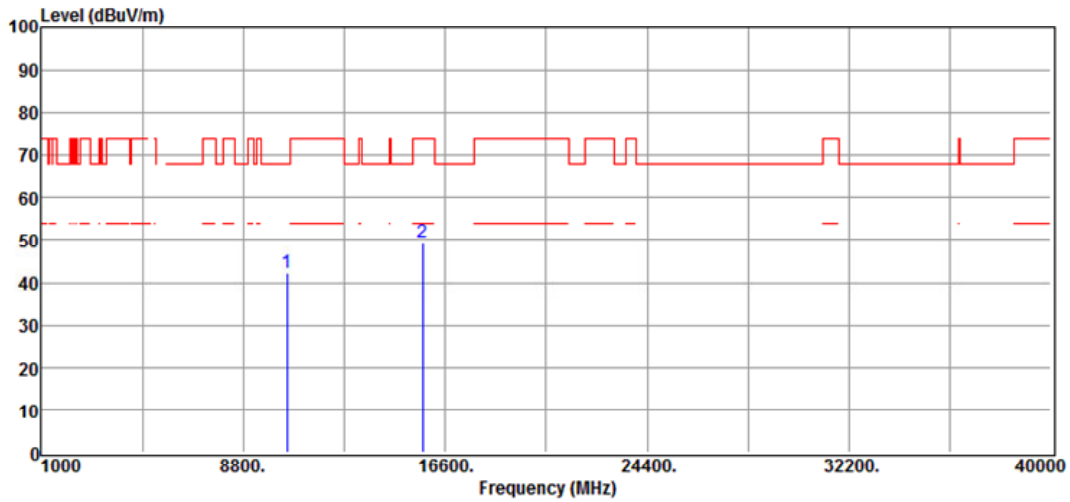

No	Freq MHz	Reading dBuV	Factor dB/m	Level dBuV/m	Limit dBuV/m	Margin dB	Remark	Pol V/H
1	10480.00	29.54	12.63	42.17	68.20	-26.03	Peak	HORIZONTAL
2	15720.00	31.30	18.16	49.46	74.00	-24.54	Peak	HORIZONTAL

International Standard Laboratory Corp.
Company Address: No.120, Lane 180, Hsin Ho Rd.
Lung-Tan Dist., Tao Yuan City 325, Taiwan

Date: 2023-12-06

Project Number. : 23LR0158 Temp.(°C)/RH(%) : 25/60
Test Mode : Wifi5G HT20 mode Tx low ch Tested by : Bill Huang

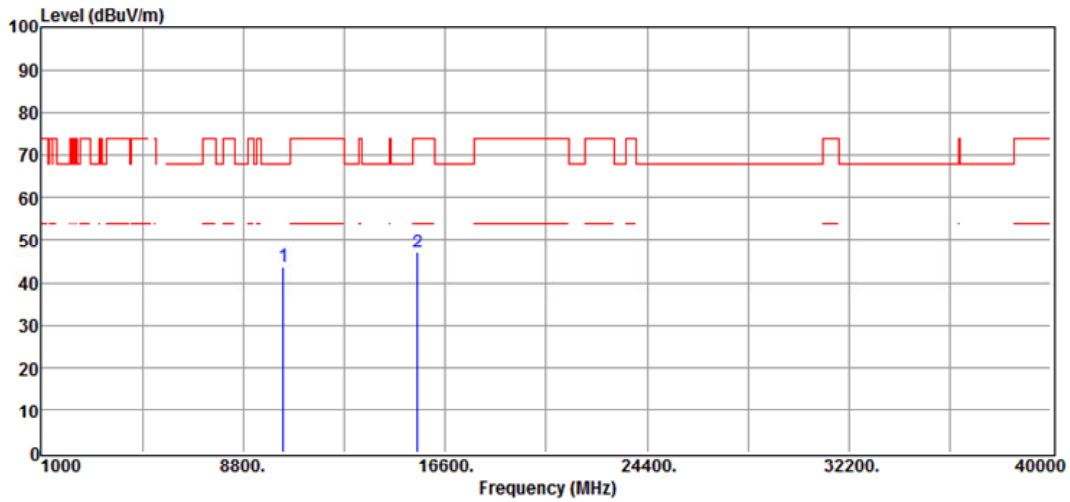

No	Freq MHz	Reading dBuV	Factor dB/m	Level dBuV/m	Limit dBuV/m	Margin dB	Remark	Pol V/H
1	10360.00	31.24	12.33	43.57	68.20	-24.63	Peak	VERTICAL
2	15540.00	28.78	18.17	46.95	74.00	-27.05	Peak	VERTICAL

International Standard Laboratory Corp.
Company Address: No.120, Lane 180, Hsin Ho Rd.
Lung-Tan Dist., Tao Yuan City 325, Taiwan

Date: 2023-12-06

Project Number. : 23LR0158 Temp.(°C)/RH(%) : 25/60
Test Mode : Wifi5G HT20 mode Tx low ch Tested by : Bill Huang

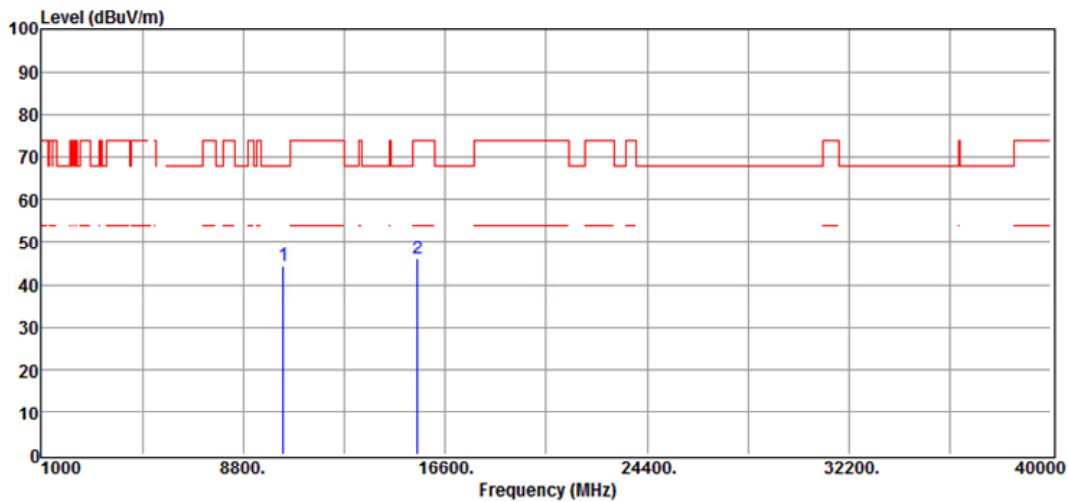

No	Freq MHz	Reading dBuV	Factor dB/m	Level dBuV/m	Limit dBuV/m	Margin dB	Remark	Pol V/H
1	10360.00	31.85	12.33	44.18	68.20	-24.02	Peak	HORIZONTAL
2	15540.00	27.88	18.17	46.05	74.00	-27.95	Peak	HORIZONTAL

International Standard Laboratory Corp.
Company Address: No.120, Lane 180, Hsin Ho Rd.
Lung-Tan Dist., Tao Yuan City 325, Taiwan

Date: 2023-12-06

Project Number. : 23LR0158 Temp.(°C)/RH(%) : 25/60
Test Mode : Wifi5G HT20 mode Tx mid ch Tested by : Bill Huang

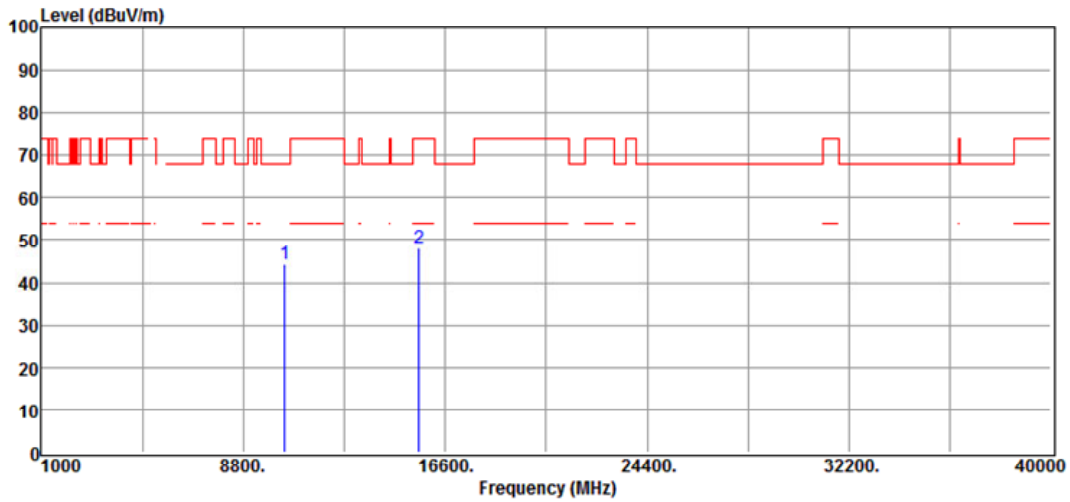

No	Freq MHz	Reading dBuV	Factor dB/m	Level dBuV/m	Limit dBuV/m	Margin dB	Remark	Pol V/H
1	10400.00	31.82	12.52	44.34	68.20	-23.86	Peak	VERTICAL
2	15600.00	29.85	18.31	48.16	74.00	-25.84	Peak	VERTICAL

International Standard Laboratory Corp.
Company Address: No.120, Lane 180, Hsin Ho Rd.
Lung-Tan Dist., Tao Yuan City 325, Taiwan

Date: 2023-12-06

Project Number. : 23LR0158 Temp.(°C)/RH(%) : 25/60
Test Mode : Wifi5G HT20 mode Tx mid ch Tested by : Bill Huang

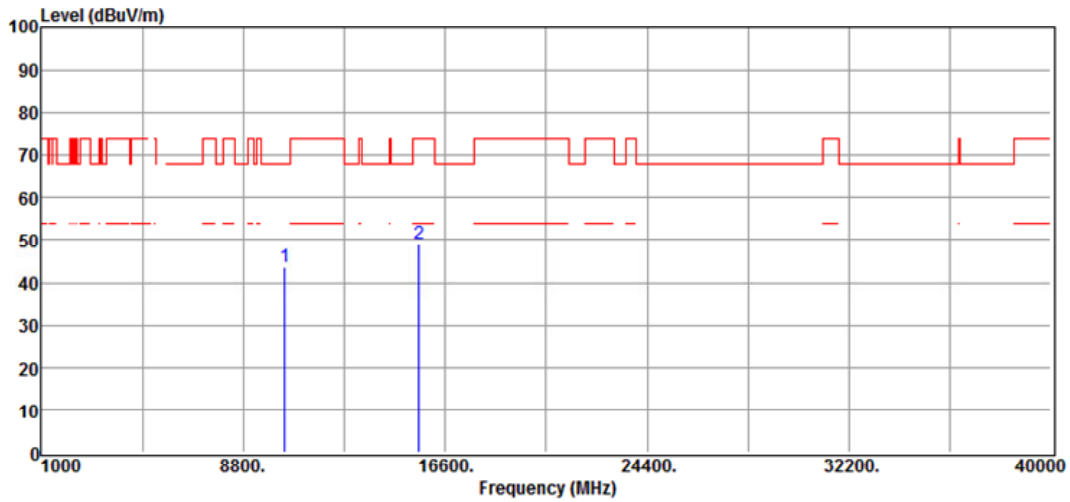

No	Freq MHz	Reading dBuV	Factor dB/m	Level dBuV/m	Limit dBuV/m	Margin dB	Remark	Pol V/H
1	10400.00	31.26	12.52	43.78	68.20	-24.42	Peak	HORIZONTAL
2	15600.00	30.87	18.31	49.18	74.00	-24.82	Peak	HORIZONTAL

International Standard Laboratory Corp.
Company Address: No.120, Lane 180, Hsin Ho Rd.
Lung-Tan Dist., Tao Yuan City 325, Taiwan

Date: 2023-12-06

Project Number. : 23LR0158 Temp.(°C)/RH(%) : 25/60
Test Mode : Wifi5G HT20 mode Tx high ch Tested by : Bill Huang

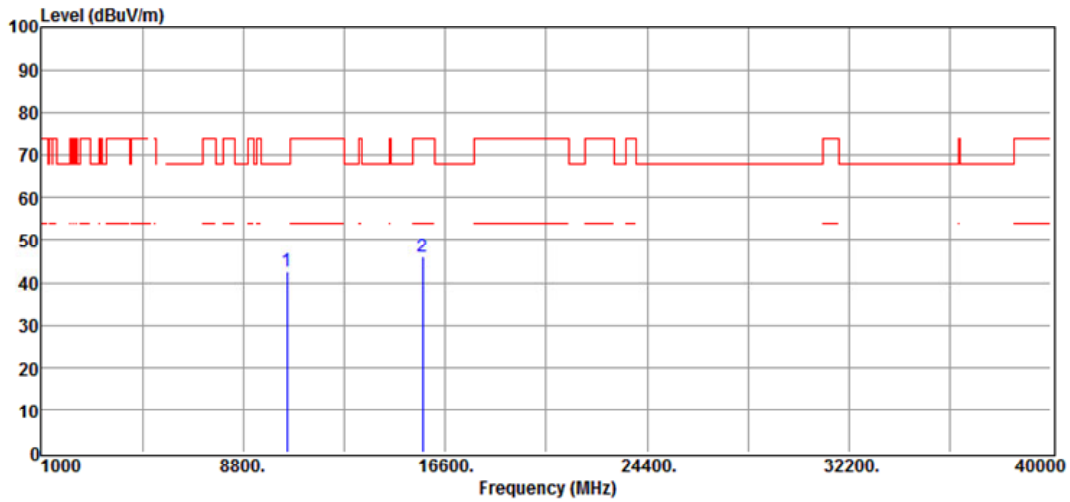

No	Freq MHz	Reading dBuV	Factor dB/m	Level dBuV/m	Limit dBuV/m	Margin dB	Remark	Pol V/H
1	10480.00	30.15	12.63	42.78	68.20	-25.42	Peak	VERTICAL
2	15720.00	27.90	18.16	46.06	74.00	-27.94	Peak	VERTICAL

International Standard Laboratory Corp.
Company Address: No.120, Lane 180, Hsin Ho Rd.
Lung-Tan Dist., Tao Yuan City 325, Taiwan

Date: 2023-12-06

Project Number. : 23LR0158 Temp.(°C)/RH(%) : 25/60
Test Mode : Wifi5G HT20 mode Tx high ch Tested by : Bill Huang

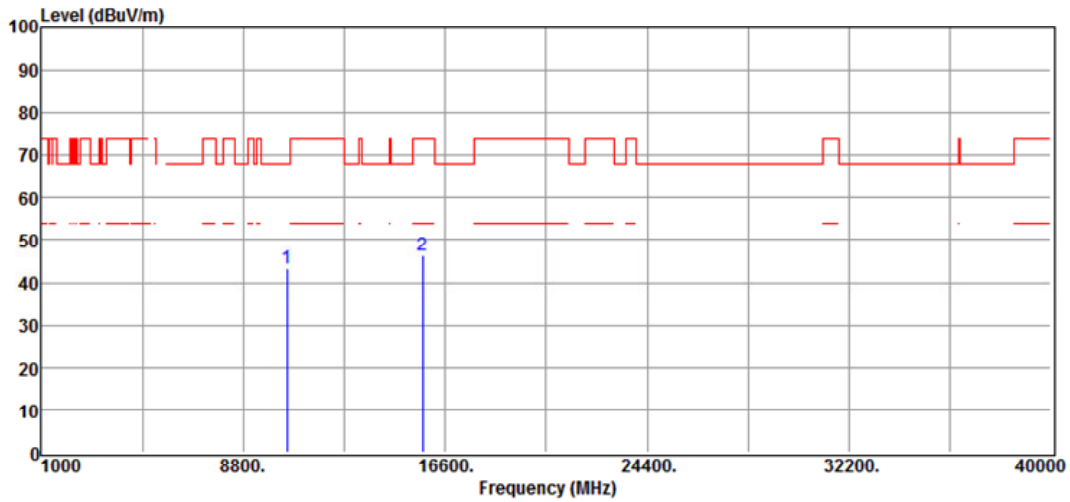

No	Freq MHz	Reading dBuV	Factor dB/m	Level dBuV/m	Limit dBuV/m	Margin dB	Remark	Pol V/H
1	10480.00	30.54	12.63	43.17	68.20	-25.03	Peak	HORIZONTAL
2	15720.00	28.30	18.16	46.46	74.00	-27.54	Peak	HORIZONTAL

International Standard Laboratory Corp.
Company Address: No.120, Lane 180, Hsin Ho Rd.
Lung-Tan Dist., Tao Yuan City 325, Taiwan

Date: 2024-04-03

Project Number. : 23LR0158 Temp.(°C)/RH(%) : 25/60
Test Mode : Wifi5G VHT20 mode Tx low ch Tested by : Bill Huang

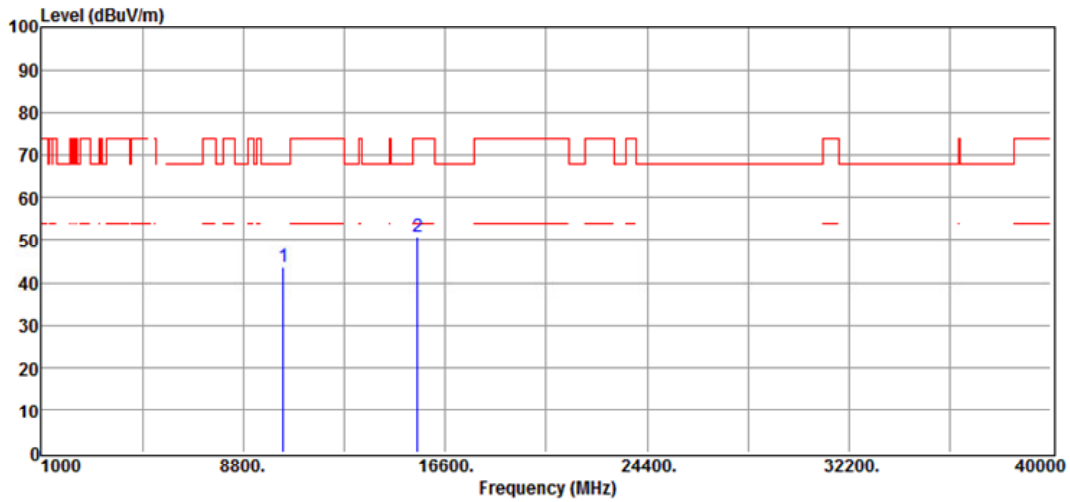

No	Freq MHz	Reading dBuV	Factor dB/m	Level dBuV/m	Limit dBuV/m	Margin dB	Remark	Pol V/H
1	10360.00	31.24	12.33	43.57	68.20	-24.63	Peak	VERTICAL
2	15540.00	32.78	18.17	50.95	74.00	-23.05	Peak	VERTICAL

International Standard Laboratory Corp.
Company Address: No.120, Lane 180, Hsin Ho Rd.
Lung-Tan Dist., Tao Yuan City 325, Taiwan

Date: 2024-04-03

Project Number. : 23LR0158 Temp.(°C)/RH(%) : 25/60
Test Mode : Wifi5G VHT20 mode Tx low ch Tested by : Bill Huang

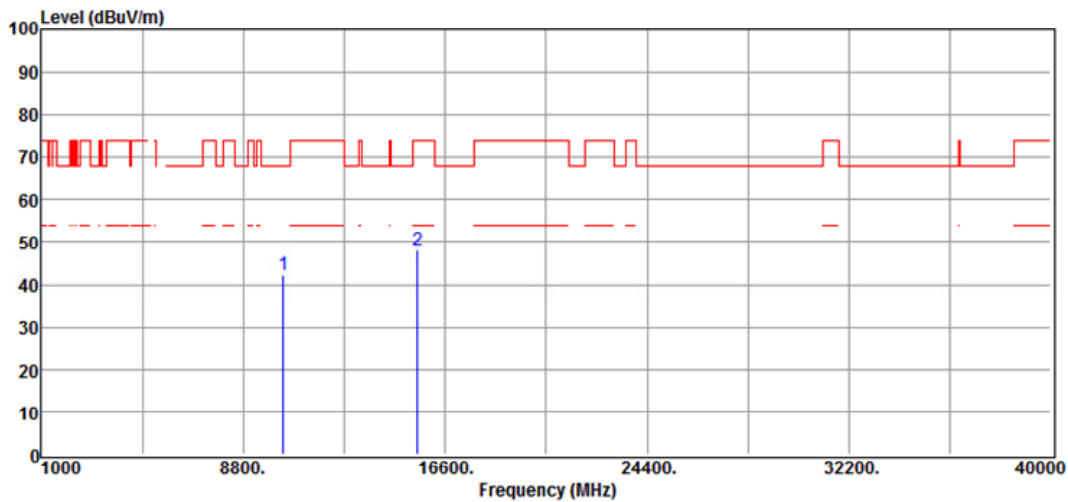

No	Freq MHz	Reading dBuV	Factor dB/m	Level dBuV/m	Limit dBuV/m	Margin dB	Remark	Pol V/H
1	10360.00	29.85	12.33	42.18	68.20	-26.02	Peak	HORIZONTAL
2	15540.00	29.88	18.17	48.05	74.00	-25.95	Peak	HORIZONTAL

International Standard Laboratory Corp.
Company Address: No.120, Lane 180, Hsin Ho Rd.
Lung-Tan Dist., Tao Yuan City 325, Taiwan

Date: 2024-04-03

Project Number. : 23LR0158 Temp.(°C)/RH(%) : 25/60
Test Mode : Wifi5G VHT20 mode Tx mid ch Tested by : Bill Huang

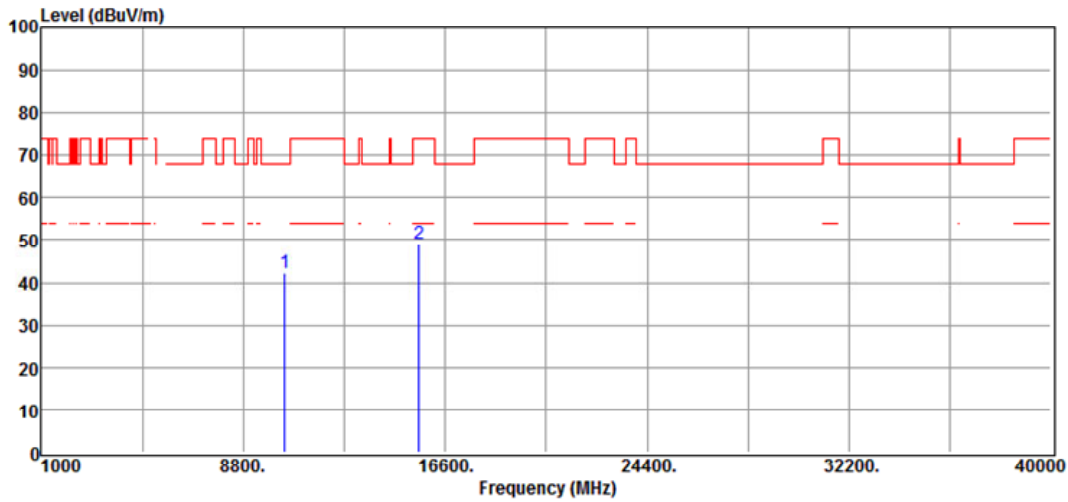

No	Freq MHz	Reading dBuV	Factor dB/m	Level dBuV/m	Limit dBuV/m	Margin dB	Remark	Pol V/H
1	10400.00	29.82	12.52	42.34	68.20	-25.86	Peak	VERTICAL
2	15600.00	30.85	18.31	49.16	74.00	-24.84	Peak	VERTICAL

International Standard Laboratory Corp.
Company Address: No.120, Lane 180, Hsin Ho Rd.
Lung-Tan Dist., Tao Yuan City 325, Taiwan

Date: 2024-04-03

Project Number. : 23LR0158 Temp.(°C)/RH(%) : 25/60
Test Mode : Wifi5G VHT20 mode Tx mid ch Tested by : Bill Huang

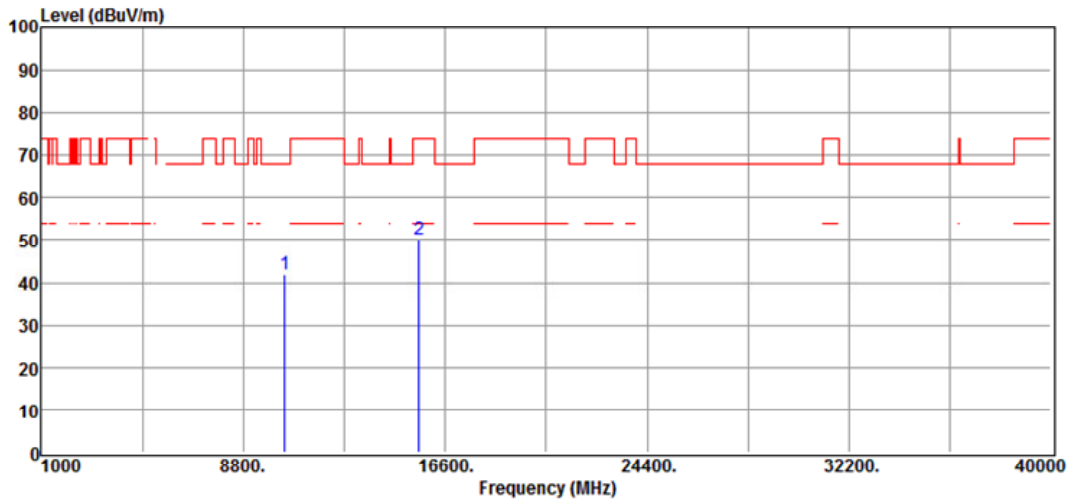

No	Freq MHz	Reading dBuV	Factor dB/m	Level dBuV/m	Limit dBuV/m	Margin dB	Remark	Pol V/H
1	10400.00	29.26	12.52	41.78	68.20	-26.42	Peak	HORIZONTAL
2	15600.00	31.87	18.31	50.18	74.00	-23.82	Peak	HORIZONTAL

International Standard Laboratory Corp.
Company Address: No.120, Lane 180, Hsin Ho Rd.
Lung-Tan Dist., Tao Yuan City 325, Taiwan

Date: 2024-04-03

Project Number. : 23LR0158 Temp.(°C)/RH(%) : 25/60
Test Mode : Wifi5G VHT20 mode Tx high ch Tested by :
Bill Huang

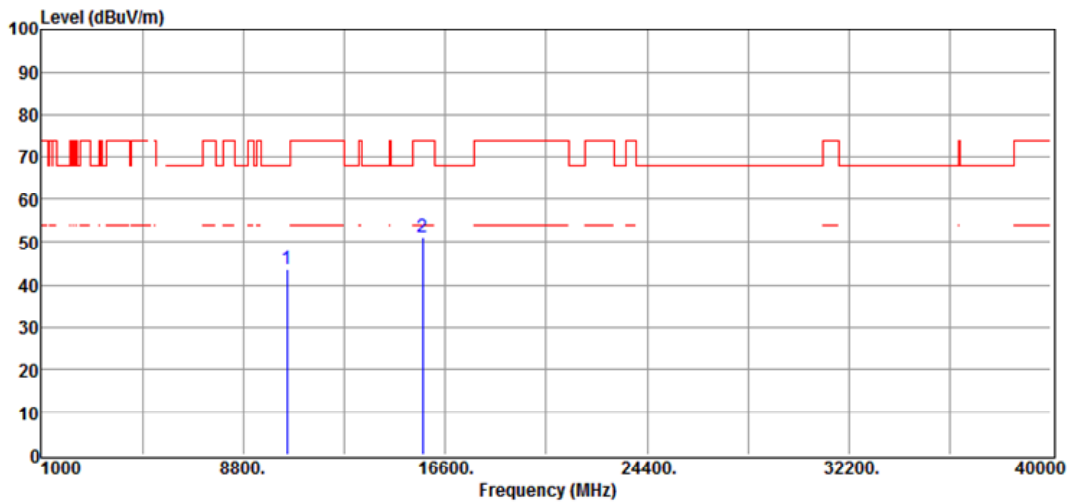

No	Freq MHz	Reading dBuV	Factor dB/m	Level dBuV/m	Limit dBuV/m	Margin dB	Remark	Pol V/H
1	10480.00	31.15	12.63	43.78	68.20	-24.42	Peak	VERTICAL
2	15720.00	32.90	18.16	51.06	74.00	-22.94	Peak	VERTICAL

International Standard Laboratory Corp.
Company Address: No.120, Lane 180, Hsin Ho Rd.
Lung-Tan Dist., Tao Yuan City 325, Taiwan

Date: 2024-04-03

Project Number. : 23LR0158 Temp.(°C)/RH(%) : 25/60
Test Mode : Wifi5G VHT20 mode Tx high ch Tested by :
Bill Huang

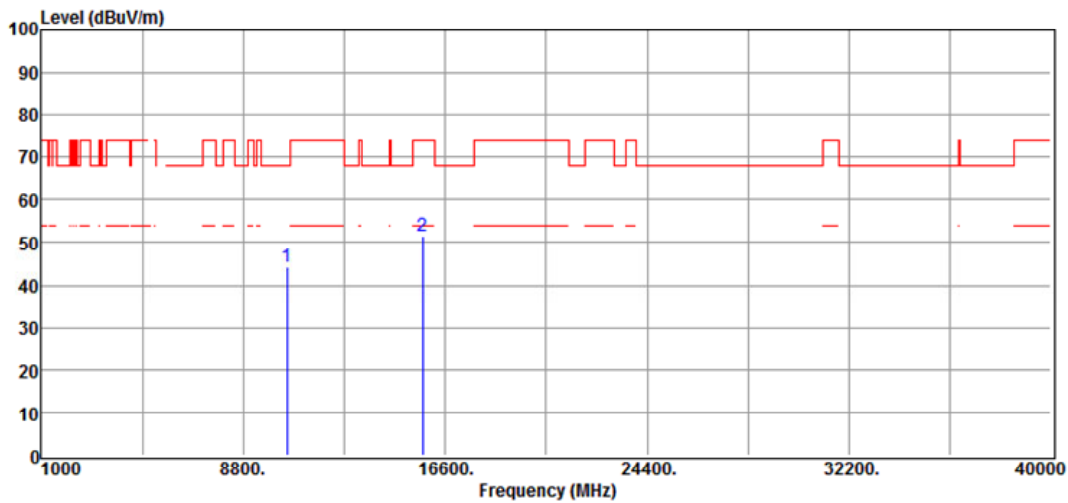

No	Freq MHz	Reading dBuV	Factor dB/m	Level dBuV/m	Limit dBuV/m	Margin dB	Remark	Pol V/H
1	10480.00	31.54	12.63	44.17	68.20	-24.03	Peak	HORIZONTAL
2	15720.00	33.30	18.16	51.46	74.00	-22.54	Peak	HORIZONTAL

Band Edges test -Radiated

International Standard Laboratory Corp.
Company Address:No.120,Lane 180, Hsin Ho Rd.
Lung-Tan Dist., Tao Yuan City 325, Taiwa

Date: 2023-11-28

Project Number. : 23LR0158 Temp.(°C)/RH(%) : 25/60

Test Mode : Wifi5G a Bandedge Tested by : Bill Huang

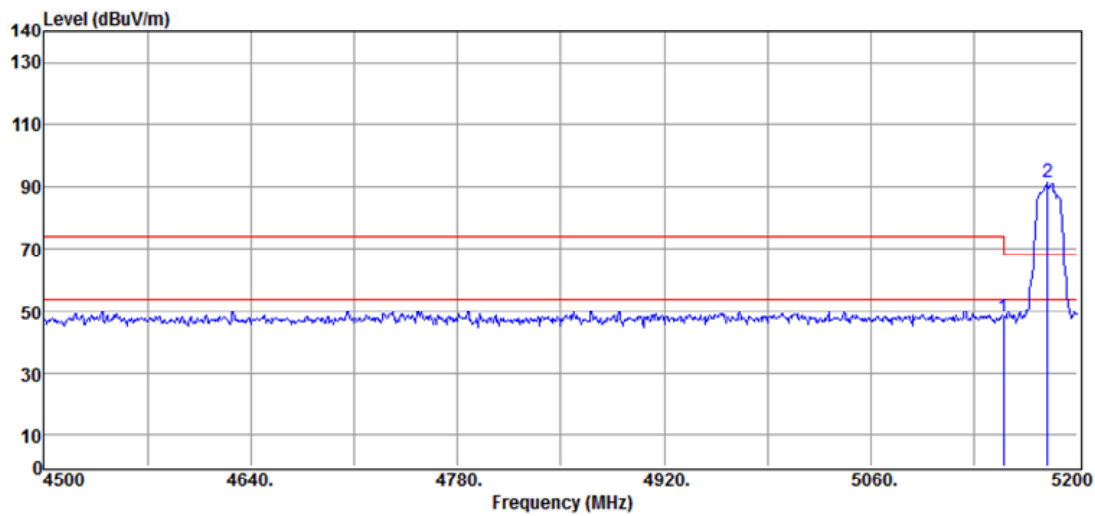

No	Freq MHz	Reading dBuV	Factor dB/m	Level dBuV/m	Limit dBuV/m	Margin dB	Remark	Pol V/H
1	5150.00	41.68	6.27	47.95	74.00	-26.05	Peak	VERTICAL
2	5179.70	84.76	6.43	91.19	F	--	Peak	VERTICAL

Note: "F" denotes fundamental frequency.

International Standard Laboratory Corp.
Company Address: No.120, Lane 180, Hsin Ho Rd.
Lung-Tan Dist., Tao Yuan City 325, Taiwan

Date: 2023-11-28

Project Number. : 23LR0158 Temp.(°C)/RH(%) : 25/60
Test Mode : Wifi5G a Bandedge Tested by : Bill Huang

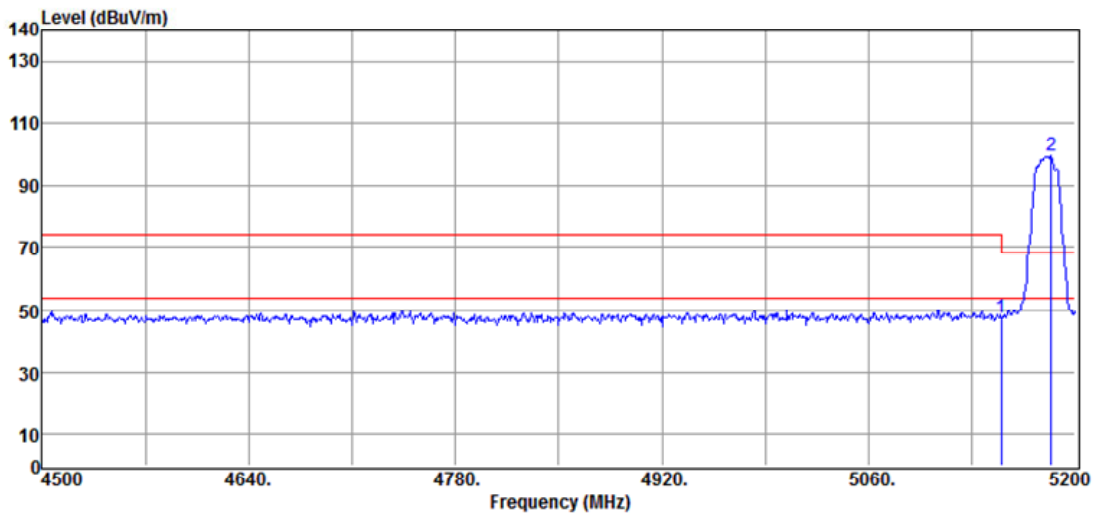

No	Freq MHz	Reading dBuV	Factor dB/m	Level dBuV/m	Limit dBuV/m	Margin dB	Remark	Pol V/H
1	5150.00	41.52	6.27	47.79	74.00	-26.21	Peak	HORIZONTAL
2	5183.90	93.22	6.45	99.67	F	--	Peak	HORIZONTAL

Note: "F" denotes fundamental frequency.

International Standard Laboratory Corp.
Company Address: No.120, Lane 180, Hsin Ho Rd.
Lung-Tan Dist., Tao Yuan City 325, Taiwan

Date: 2023-11-28

Project Number. : 23LR0158 Temp.(°C)/RH(%) : 25/60

Test Mode : Wifi5G a Bandedge Tested by : Bill Huang

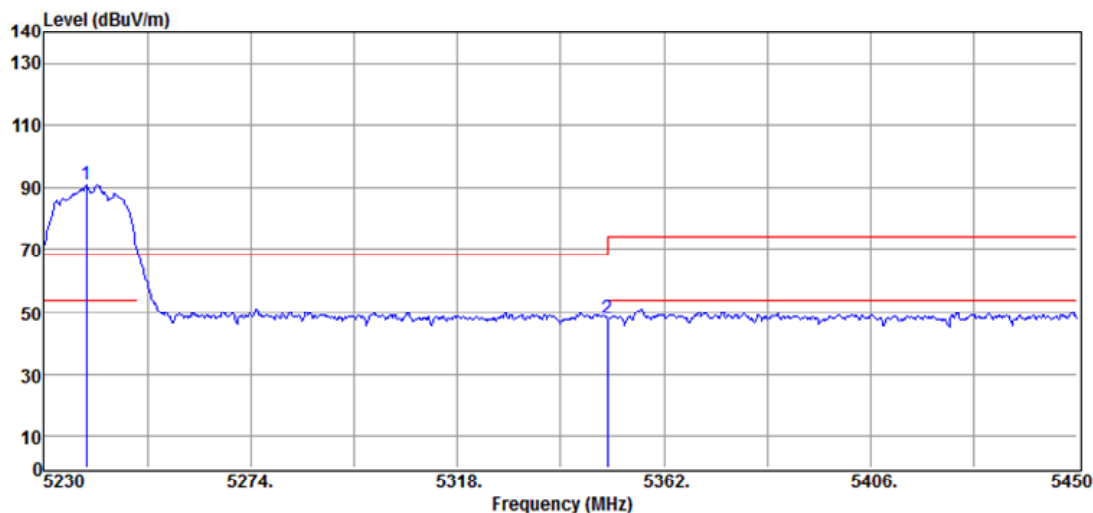

No	Freq MHz	Reading dBuV	Factor dB/m	Level dBuV/m	Limit dBuV/m	Margin dB	Remark	Pol V/H
1	5239.02	84.16	6.64	90.80	F	--	Peak	VERTICAL
2	5350.00	41.58	6.76	48.34	74.00	-25.66	Peak	VERTICAL

Note: "F" denotes fundamental frequency.

International Standard Laboratory Corp.
Company Address: No.120, Lane 180, Hsin Ho Rd.
Lung-Tan Dist., Tao Yuan City 325, Taiwan

Date: 2023-11-28

Project Number. : 23LR0158 Temp.(°C)/RH(%) : 25/60
Test Mode : Wifi5G a Bandedge Tested by : Bill Huang

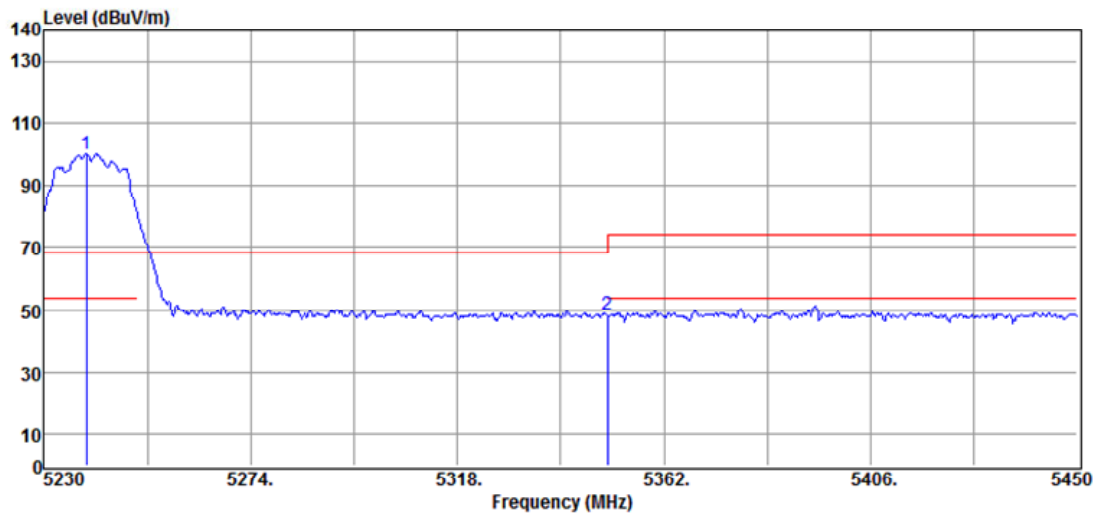

No	Freq MHz	Reading dBuV	Factor dB/m	Level dBuV/m	Limit dBuV/m	Margin dB	Remark	Pol V/H
1	5239.02	93.45	6.64	100.09	F	--	Peak	HORIZONTAL
2	5350.00	41.80	6.76	48.56	74.00	-25.44	Peak	HORIZONTAL

Note: "F" denotes fundamental frequency.

International Standard Laboratory Corp.
Company Address: No.120, Lane 180, Hsin Ho Rd.
Lung-Tan Dist., Tao Yuan City 325, Taiwan

Date: 2023-11-28

Project Number. : 23LR0158 Temp.(°C)/RH(%) : 25/60
Test Mode : Wifi5G HT20 Bandedge Tested by : Bill Huang

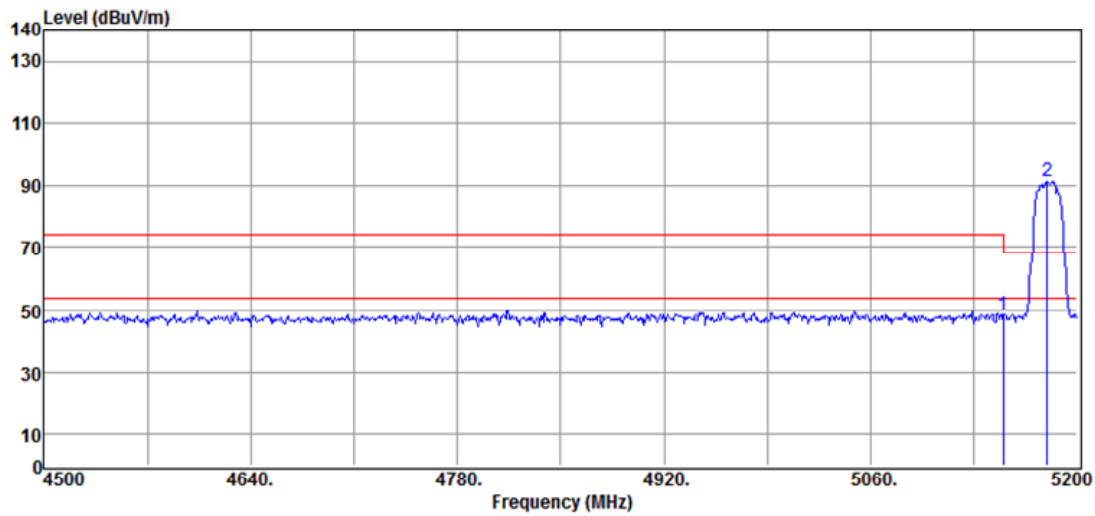

No	Freq MHz	Reading dBuV	Factor dB/m	Level dBuV/m	Limit dBuV/m	Margin dB	Remark	Pol V/H
1	5150.00	42.23	6.27	48.50	74.00	-25.50	Peak	VERTICAL
2	5179.70	84.87	6.43	91.30	F	--	Peak	VERTICAL

Note: "F" denotes fundamental frequency.

International Standard Laboratory Corp.
Company Address: No.120, Lane 180, Hsin Ho Rd.
Lung-Tan Dist., Tao Yuan City 325, Taiwan

Date: 2023-11-28

Project Number. : 23LR0158 Temp.(°C)/RH(%) : 25/60

Test Mode : Wifi5G HT20 Bandedge Tested by : Bill Huang

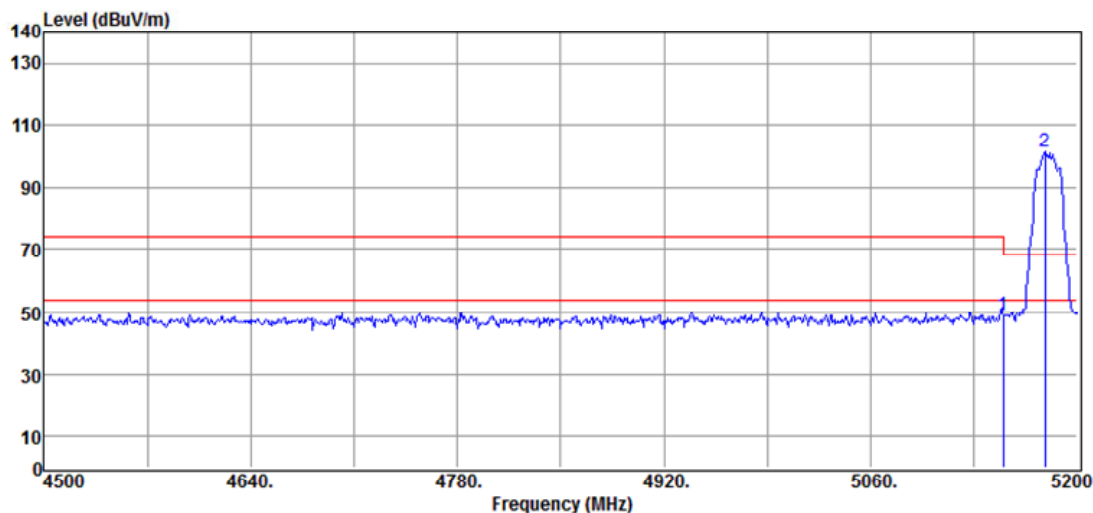

No	Freq MHz	Reading dBuV	Factor dB/m	Level dBuV/m	Limit dBuV/m	Margin dB	Remark	Pol V/H
1	5150.00	42.67	6.27	48.94	74.00	-25.06	Peak	HORIZONTAL
2	5178.30	95.03	6.42	101.45	F	--	Peak	HORIZONTAL

Note: "F" denotes fundamental frequency.

International Standard Laboratory Corp.
Company Address: No.120, Lane 180, Hsin Ho Rd.
Lung-Tan Dist., Tao Yuan City 325, Taiwan

Date: 2023-11-28

Project Number. : 23LR0158 Temp.(°C)/RH(%) : 25/60
Test Mode : Wifi5G HT20 Bandedge Tested by : Bill Huang

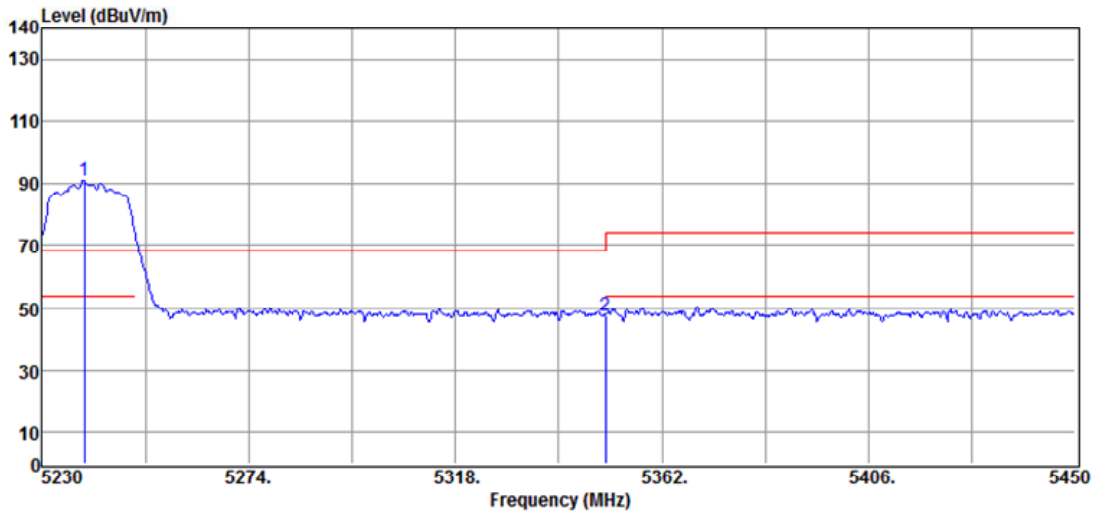

No	Freq MHz	Reading dBuV	Factor dB/m	Level dBuV/m	Limit dBuV/m	Margin dB	Remark	Pol V/H
1	5239.02	84.40	6.64	91.04	F	--	Peak	VERTICAL
2	5350.00	41.08	6.76	47.84	74.00	-26.16	Peak	VERTICAL

Note: "F" denotes fundamental frequency.

International Standard Laboratory Corp.
Company Address: No.120, Lane 180, Hsin Ho Rd.
Lung-Tan Dist., Tao Yuan City 325, Taiwan

Date: 2023-11-28

Project Number. : 23LR0158 Temp.(°C)/RH(%) : 25/60

Test Mode : Wifi5G HT20 Bandedge Tested by : Bill Huang

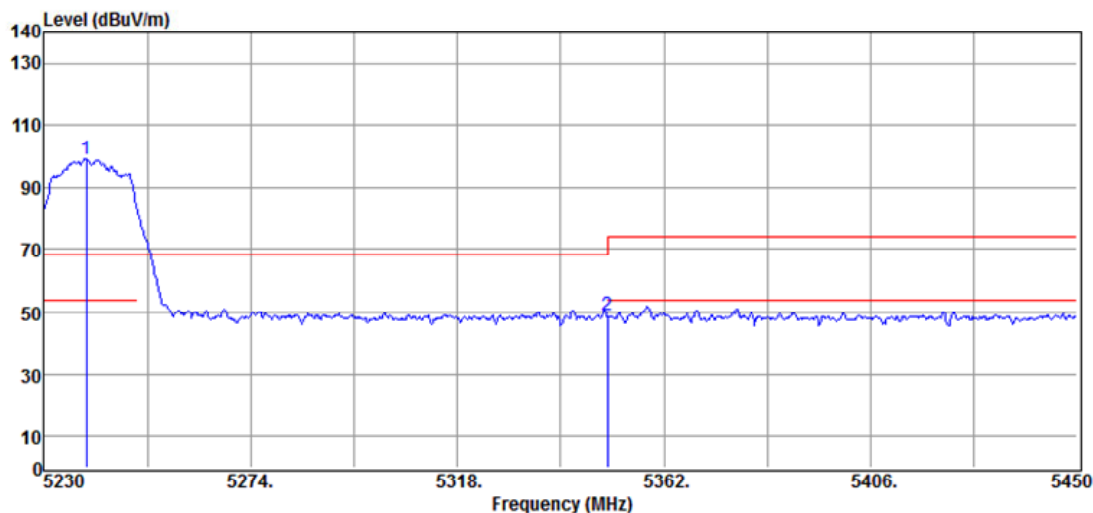

No	Freq MHz	Reading dBuV	Factor dB/m	Level dBuV/m	Limit dBuV/m	Margin dB	Remark	Pol V/H
1	5239.02	92.71	6.64	99.35	F	--	Peak	HORIZONTAL
2	5350.00	42.52	6.76	49.28	74.00	-24.72	Peak	HORIZONTAL

Note: "F" denotes fundamental frequency.

International Standard Laboratory Corp.
Company Address: No.120, Lane 180, Hsin Ho Rd.
Lung-Tan Dist., Tao Yuan City 325, Taiwan

Date: 2023-11-28

Project Number. : 23LR0158 Temp.(°C)/RH(%) : 25/60

Test Mode : Wifi5G VHT20 Bandedge Tested by : Bill Huang

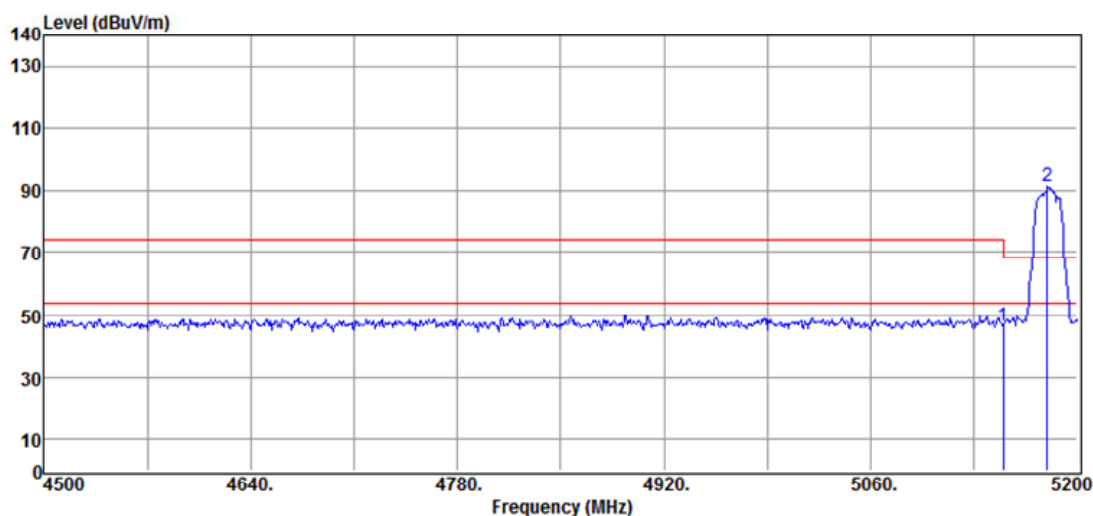

No	Freq MHz	Reading dBuV	Factor dB/m	Level dBuV/m	Limit dBuV/m	Margin dB	Remark	Pol V/H
1	5150.00	40.62	6.27	46.89	74.00	-27.11	Peak	VERTICAL
2	5179.70	84.75	6.43	91.18	F	--	Peak	VERTICAL

Note: "F" denotes fundamental frequency.

International Standard Laboratory Corp.
Company Address: No.120, Lane 180, Hsin Ho Rd.
Lung-Tan Dist., Tao Yuan City 325, Taiwan

Date: 2023-11-28

Project Number. : 23LR0158 Temp.(°C)/RH(%) : 25/60
Test Mode : Wifi5G VHT20 Bandedge Tested by : Bill Huang

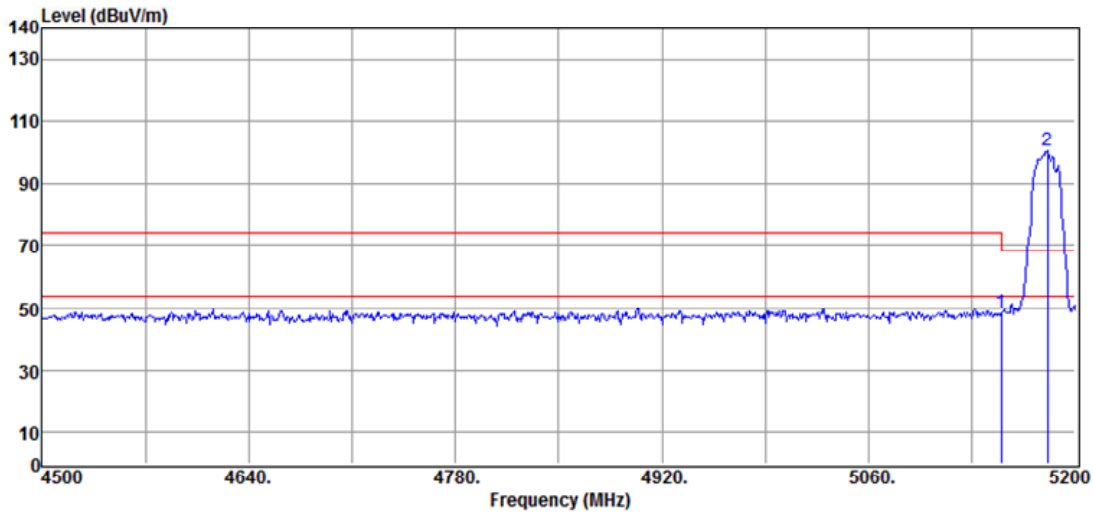

No	Freq MHz	Reading dBuV	Factor dB/m	Level dBuV/m	Limit dBuV/m	Margin dB	Remark	Pol V/H
1	5150.00	42.54	6.27	48.81	74.00	-25.19	Peak	HORIZONTAL
2	5181.10	94.13	6.43	100.56	F	--	Peak	HORIZONTAL

Note: "F" denotes fundamental frequency.

International Standard Laboratory Corp.
Company Address: No.120, Lane 180, Hsin Ho Rd.
Lung-Tan Dist., Tao Yuan City 325, Taiwan

Date: 2023-11-28

Project Number. : 23LR0158 Temp.(°C)/RH(%) : 25/60
Test Mode : Wifi5G VHT20 Bandedge Tested by : Bill Huang

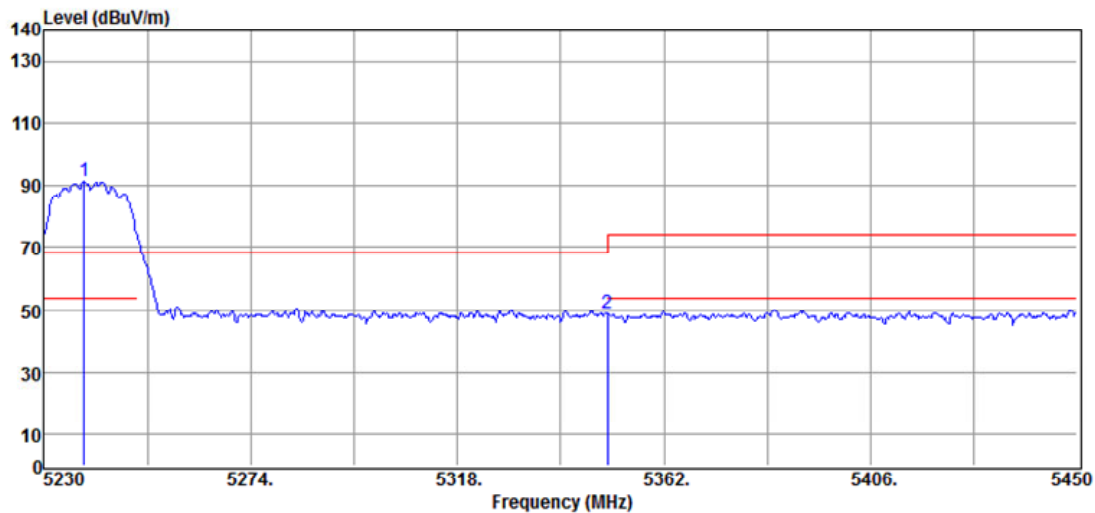

No	Freq MHz	Reading dBuV	Factor dB/m	Level dBuV/m	Limit dBuV/m	Margin dB	Remark	Pol V/H
1	5238.58	84.53	6.64	91.17	F	--	Peak	VERTICAL
2	5350.00	42.28	6.76	49.04	74.00	-24.96	Peak	VERTICAL

Note: "F" denotes fundamental frequency.

International Standard Laboratory Corp.
Company Address: No.120, Lane 180, Hsin Ho Rd.
Lung-Tan Dist., Tao Yuan City 325, Taiwan

Date: 2023-11-28

Project Number. : 23LR0158 Temp.(°C)/RH(%) : 25/60
Test Mode : Wifi5G VHT20 Bandedge Tested by : Bill Huang

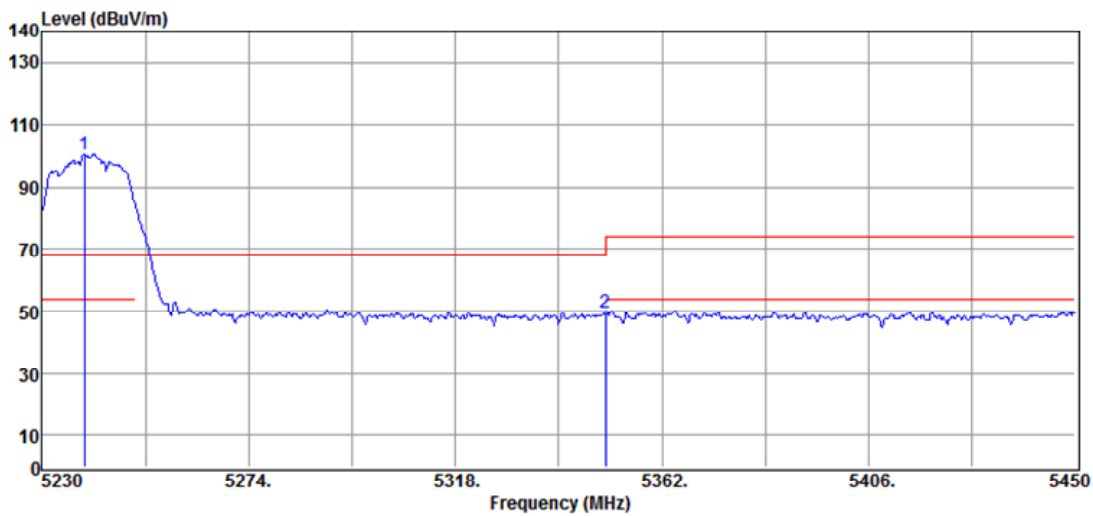

No	Freq MHz	Reading dBuV	Factor dB/m	Level dBuV/m	Limit dBuV/m	Margin dB	Remark	Pol V/H
1	5239.02	93.94	6.64	100.58	F	--	Peak	HORIZONTAL
2	5350.00	43.00	6.76	49.76	74.00	-24.24	Peak	HORIZONTAL

Note: "F" denotes fundamental frequency.

10. Transmission in the Absence of Data

10.1. Standard Applicable

According to §15.407(c)

The device shall automatically discontinue transmission in case of either absence of information to transmit or operational failure. These provisions are not intended to preclude the transmission of control or signaling information or the use of repetitive codes used by certain digital technologies to complete frame or burst intervals. Applicants shall include in their application for equipment authorization a description of how this requirement is met.

10.2. Result:

Pass, the device is compliance with 802.11 a/ b/g/n ac standard, the short control signal is appear during no transmission period.

11. Antenna Requirement

11.1. Standard Applicable

According to §15.203, Antenna requirement.

An intentional radiator shall be designed to ensure that no antenna other than that furnished by the responsible party shall be used with the device. The use of a permanently attached antenna or of an antenna that uses a unique coupling to the intentional radiator shall be considered sufficient to comply with the provisions of this Section. The manufacturer may design the unit so that a broken antenna can be replaced by the user, but the use of a standard antenna jack or electrical connector is prohibited. This requirement does not apply to carrier current devices or to devices operated under the provisions of Sections 15.211, 15.213, 15.217, 15.219, or 15.221. Further, this requirement does not apply to intentional radiators that must be professionally installed, such as perimeter protection systems and some field disturbance sensors, or to other intentional radiators which, in accordance with Section 15.31(d), must be measured at the installation site. However, the installer shall be responsible for ensuring that the proper antenna is employed so that the limits in this Part are not exceeded.

11.2. Antenna Connected Construction

The directional gains of antenna used for transmitting is below table, and the antenna connector is designed with unique type RF connector and no consideration of replacement. Please see EUT photo and antenna spec. for details.

Antenna Designation:

	Antenna Type	Brand	Model	Peak Gain	Frequency Range	Connector Type
1	PCB	ShenZhen Powerful Technology CO., Limited	YL1360-WIFI-V1-L60	3.12dBi	2400-2500 MHz	i-pex
2	PCB	ShenZhen Powerful Technology CO., Limited	YL1360-WIFI-V1-L60	4.54dBi	5150-5850 MHz	i-pex

12. TPC and DFS Measurement

12.1. TPC: Standard Applicable

According to §15.407(h)(1), Transmit power control (TPC). U-NII devices operating in the 5.25-5.35 GHz band and the 5.47-5.725 GHz band shall employ a TPC mechanism. The U-NII device is required to have the capability to operate at least 6 dB below the mean EIRP value of 30 dBm. A TPC mechanism is not required for systems with an e.i.r.p. of less than 500 mW.

12.2. DFS: Standard Applicable

According to §15.407(h)(2), Radar Detection Function of Dynamic Frequency Selection (DFS). U-NII devices operating in the 5.25-5.35 GHz and 5.47-5.725 GHz bands shall employ a DFS radar detection.

13.2.1. Limit

Table 1: Applicability of DFS requirements prior to use of a channel

Requirement	Operational Mode		
	Slave	Client(without radar detection)	Client(with radar detection)
Non-occupancy Period	Yes	Not required	Yes
DFS Detection Threshold	Yes	Not required	Yes
Channel Availability Check Time	Yes	Not required	Not required
Uniform Spreading	Yes	Not required	Not required
U-NII Detection Bandwidth	Yes	Not required	Yes

Table 2: Applicability of DFS requirements during normal operation

Requirement	Operational Mode		
	Slave	Client(without radar detection)	Client(with radar detection)
DFS Detection Threshold	Yes	Not required	Yes
Channel Closing Transmission Time	Yes	Yes	Yes
Channel Move Time	Yes	Yes	Yes
U-NII Detection Bandwidth	Yes	Not required	Yes

Refer to KDB Number: 905462 APPENDIX B COMPLIANCE MEASUREMENT PROCEDURES FOR UNLICENSED-NATIONAL INFORMATION INFRASTRUCTURE DEVICES OPERATING IN THE 5.25-5.35 GHz AND 5.47-5.725 GHz BANDS INCORPORATING DYNAMIC FREQUENCY SELECTION.

Table 3: Interference Threshold values, Master or Client incorporating In-Service Monitoring

Maximum Transmit Power	Value (see note)
≥ 200 milliwatt	-64 dBm
< 200 milliwatt	-62 dBm
Note 1: This is the level at the input of the receiver assuming a 0 dBi receive antenna Note 2: Throughout these test procedures an additional 1 dB has been added to the amplitude of the test transmission waveforms to account for variations in measurement equipment. This will ensure that the test signal is at or above the detection threshold level to trigger a DFS response.	

Table 4: DFS Response requirement values

Parameter	Value
<i>Non-occupancy period</i>	Minimum 30 minutes
<i>Channel Availability Check Time</i>	60 seconds
<i>Channel Move Time</i>	10 seconds See Note 1.
<i>Channel Closing Transmission Time</i>	200 milliseconds + an aggregate of 60 milliseconds over remaining 10 second period. See Notes 1 and 2.
<i>U-NII Detection Bandwidth</i>	Minimum 80% of the U-NII 99% transmission power bandwidth. See Note 3.
<p>Note 1: The instant that the <i>Channel Move Time</i> and the <i>Channel Closing Transmission Time</i> begins is as follows:</p> <ul style="list-style-type: none"> • For the Short Pulse Radar Test Signals this instant is the end of the <i>Burst</i>. • For the Frequency Hopping radar Test Signal, this instant is the end of the last radar <i>Burst</i> generated. • For the Long Pulse Radar Test Signal this instant is the end of the 12 second period defining the <i>Radar Waveform</i>. <p>Note 2: The <i>Channel Closing Transmission Time</i> is comprised of 200 milliseconds starting at the beginning of the <i>Channel Move Time</i> plus any additional intermittent control signals required to facilitate a <i>Channel</i> move (an aggregate of 60 milliseconds) during the remainder of the 10 second period. The aggregate duration of control signals will not count quiet periods in between transmissions.</p> <p>Note 3: During the <i>U-NII Detection Bandwidth</i> detection test, radar type 1 is used and for each frequency step the minimum percentage of detection is 90 percent. Measurements are performed with no data traffic.</p>	

Table 5: Radar Test Waveforms

Short Pulse Radar

Radar Type	Pulse Width (μsec)	PRI (μsec)	Number of Pulses	Minimum Percentage of Successful Detection	Minimum Number of Trials
0	1	1428	18	See Note 1	See Note 1
1	1	Test A: 15 unique PRI values randomly selected from the list of 23 PRI values in Table 5a	Roundup $\left\{ \begin{array}{l} \left(\frac{1}{360} \right) \cdot \\ \left(\frac{19 \cdot 10^6}{\text{PRI}_{\mu\text{sec}}} \right) \end{array} \right\}$	60%	30
		Test B: 15 unique PRI values randomly selected within the range of 518-3066 μsec, with a minimum increment of 1 μsec, excluding PRI values selected in Test A			
2	1-5	150-230	23-29	60%	30
3	6-10	200-500	16-18	60%	30
4	11-20	200-500	12-16	60%	30
Aggregate (Radar Types 1-4)				80%	120
Note 1: Short Pulse Radar Type 0 should be used for the detection bandwidth test, channel move time, and channel closing time tests.					

A minimum of 30 unique waveforms are required for each of the Short Pulse Radar Types 2 through 4. For Short Pulse Radar Type 1, the same waveform is used a minimum of 30 times. If more than 30 waveforms are used for Short Pulse Radar Types 2 through 4, then each additional waveform must also be unique and not repeated from the previous waveforms

Long Pulse Radar

Radar Type	Pulse Width (μsec)	Chirp Width (MHz)	PRI (μsec)	Number of Pulses per Burst	Number of Bursts	Minimum Percentage of Successful Detection	Minimum Trials
5	50-100	5-20	1000-2000	1-3	8-20	80%	30

The parameters for this waveform are randomly chosen. Thirty unique waveforms are required for the Long Pulse Radar Type waveforms. If more than 30 waveforms are used for the Long Pulse Radar Type waveforms, then each additional waveform must also be unique and not repeated from the previous waveforms.

Frequency Hopping Radar

Radar Type	Pulse Width (μsec)	PRI (μsec)	Pulses per Hop	Hopping Rate (kHz)	Hopping Sequence Length (msec)	Minimum Percentage of Successful Detection	Minimum Trials
6	1	333	9	.333	300	70%	30

For the Frequency Hopping Radar Type, the same *Burst* parameters are used for each waveform. The hopping sequence is different for each waveform and a 100-length segment is selected from the hopping sequence defined by the following algorithm: 3

The first frequency in a hopping sequence is selected randomly from the group of 475 integer frequencies from 5250 – 5724 MHz. Next, the frequency that was just chosen is removed from the group and a frequency is randomly selected from the remaining 474 frequencies in the group. This process continues until all 475 frequencies are chosen for the set. For selection of a random frequency, the frequencies remaining within the group are always treated as equally likely.

13.2.2. Test Setup

Setup for Master with injection at the Master

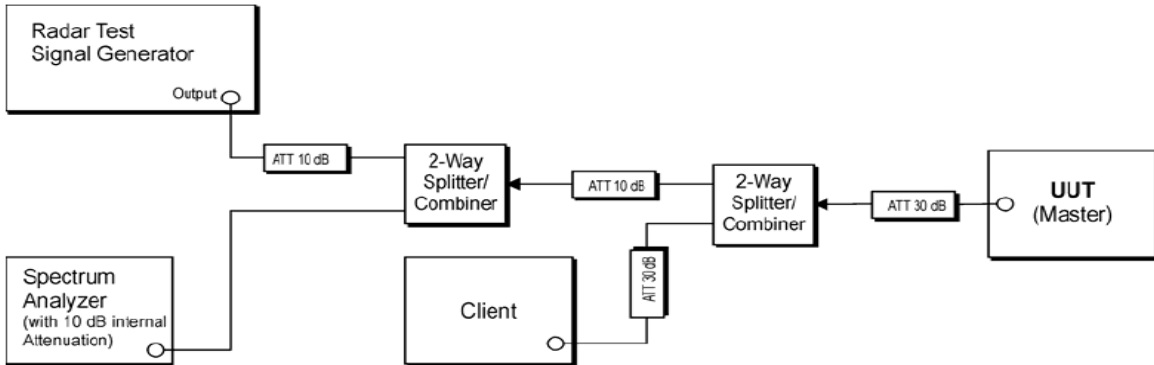

Setup for Client with injection at the Master

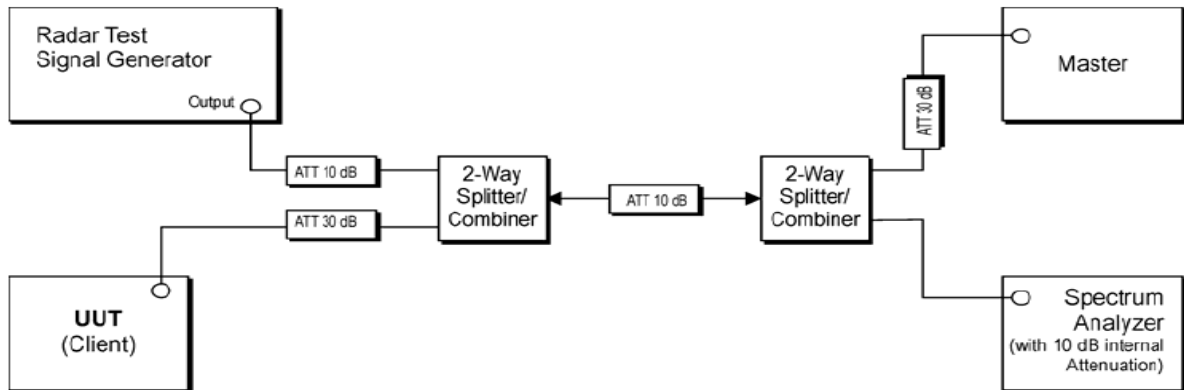

Setup for Client with injection at the Client

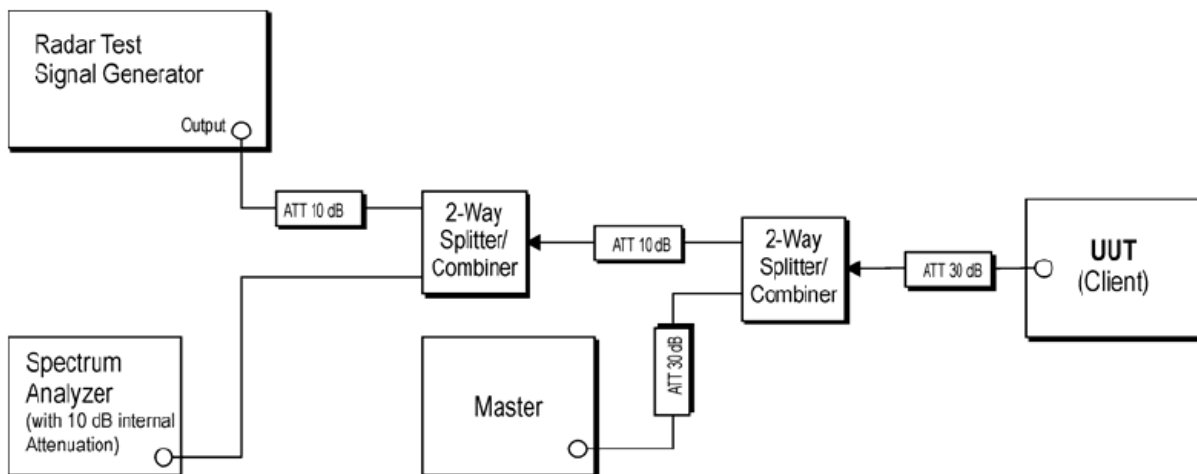

Note: device under test are configured with AP as IP based by streaming MPEG video, 30 frames per seconds

12.3. Test Equipment Used:

13. Conducted	Power Meter	Anritsu	ML2495A	1116010	09/27/2023	09/27/2024
Conducted	Power Sensor	Anritsu	MA2411B	34NKF50	09/27/2023	09/27/2024
Conducted	Temperature Chamber	KSON	THS-B4H100	2287	05/17/2023	05/17/2024
Conducted	DC Power supply	ABM	8185D	N/A	01/03/2024	01/03/2025
Conducted	AC Power supply	EXTECH	CFC105W	NA	N/A	N/A
Conducted	Spectrum analyzer	Keysight	N9010A	MY56070257	09/26/2023	09/26/2024
Conducted	Test Software	DARE	Radiation Ver:2013.1.23	NA	NA	NA
Conducted	Wideband Radio Comm. Tester	R&S	CMW500	1201.002K50108 793-JG	10/26/2023	10/26/2024
Conducted	Radio Communication Test Station	Anritsu	MT8000A	6272539604	08/30/2023	08/30/2024
Conducted	MT8000A Test Software	Anritsu	MX800000A Application Launcher v10.10.34.0	NA	NA	NA
Conducted	BT Simulator	Agilent	N4010A	MY48100200	NA	NA
Conducted	MXG Vector Signal Generator	KEYSIGHT	N5182B	MY53052399	12/26/2023	12/26/2024
Conducted (TS8997)	Wideband Radio Comm. Tester	R&S	CMW500	168811	09/13/2023	09/13/2024
Conducted (TS8997)	UP/DOWN converter	R&S	CMW-Z800A	100566	09/13/2023	09/13/2024
Conducted (TS8997)	Signal Generator	R&S	SMB100A	183701	09/14/2023	09/14/2024
Conducted (TS8997)	Vector Signal Generator	R&S	SMM100A	101908	09/13/2023	09/13/2024
Conducted (TS8997)	Signal analyzer 40GHz	R&S	FSV40	101884	09/13/2023	09/13/2024
Conducted (TS8997)	OSP150 extension unit CAM-BUS	R&S	OSP150	101107	09/15/2023	09/15/2024
Conducted (TS8997)	Test Software	R&S	EMC32 Ver:11.70.00	NA	NA	NA

12.3.1. Description of EUT :

EUT operates over the 5250-5350MHz and 5470-5725MHz ranges and EUT is a slave device (client equipment) w/o radar detection and DFS capability.

The EUT utilizes the 802.11n architecture, with a nominal channel bandwidth of 80MHz WLAN traffic is generated by streaming the mpeg file from the master to slave in full monitor video mode using the media player.

The rated output power of the master unit is >23dBm(EIRP).therefore the required interference threshold level is -64dBm. The master device as employed for the applicable DFS test is router whose FCC ID= YOR-RT1900AC for Synology

13.1. Test results

N/A.