

Dongguan Dexinda Electronic Technology Co.,Ltd

Client Dongguan Hankai Electronics Co., Ltd

TYPE transmit coil 44MM

Model NO G43.5 Magnetic disc single hole double slot back adhesive line length 11MM 6.5UH

Part numbering systey DXD20221009001

Client p/NO 101.20.04950

Enginrer NO RAO 20221009001

Date 2022-10-09

For Enginer Departner Only	
Rrvised Content	APProved Date

Prepared

RAO

Checked

Xie Liang

Approved

Xu Yan

Authorized Signaturure Company Chop		
Enginrer	QC APProved	APProved

一、 Winding Proceese:

NO	winding	wire gauge	number of turns	winding direction	notes
1	N1	2UEW-B-0.07*100P	11TS	CCW	
2					

二. FEATURES:

1.Test conditions) : 25°C,65%RH@100KHz/1V

1.1 (Inductance)

1.11 L0A (Individual coil) =3.8uH±20%

1.12 L0A(Coil+magnetic disc)=6.5uH±10%

1.2 q-value=65MIN

1.3 DC Resistance (DCR) : 55mΩ MAX

1.4 (Operating Temperature): -25°C~85°C

2.(Test instrument): L:创达 1068+1310;DCR:502BC;SIZE:Callipers

3.Material List

NO	item	material
1	WIRE	φ 0.07*100p 2UEW-1.05mm
2	FERRITE	43.5*5.3*0.8 L-shaped slot ferrite hard magnet
3	GLUE	White glue
4	SOLDER	XCD-907B
5	Adhesive	Slotted double-sided adhesive backing
6	High temperature adhesive	7MM High temperature tape
7	UL	E238500

8	
---	--



三. IRCUIT DIAGRAM

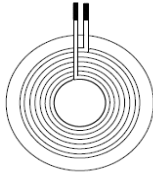

N1



单位： MM

四. OUTSIDE DIAGRA

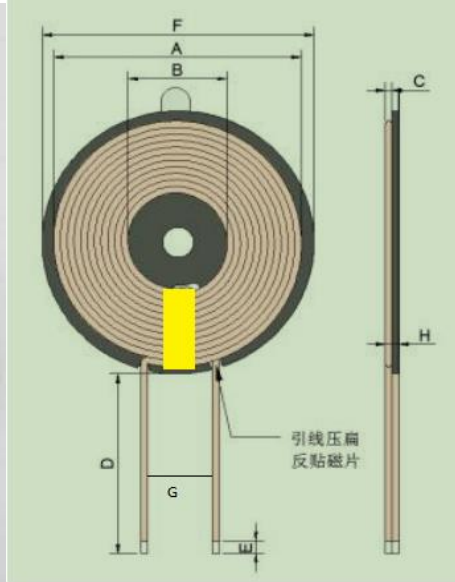

Reference image

Note: Wrap 7MM (ref) high-temperature adhesive tape around the coil outlet position

stan dard	A	B	C	D	E	F	H	G
STD	38.5±1.2	16±1.5	0.8±0.2	11±2	2-5	44Max	2.6Max	9-15

unit: MM

五. PACKAGE

5.1 包装图片 Packing pictures:

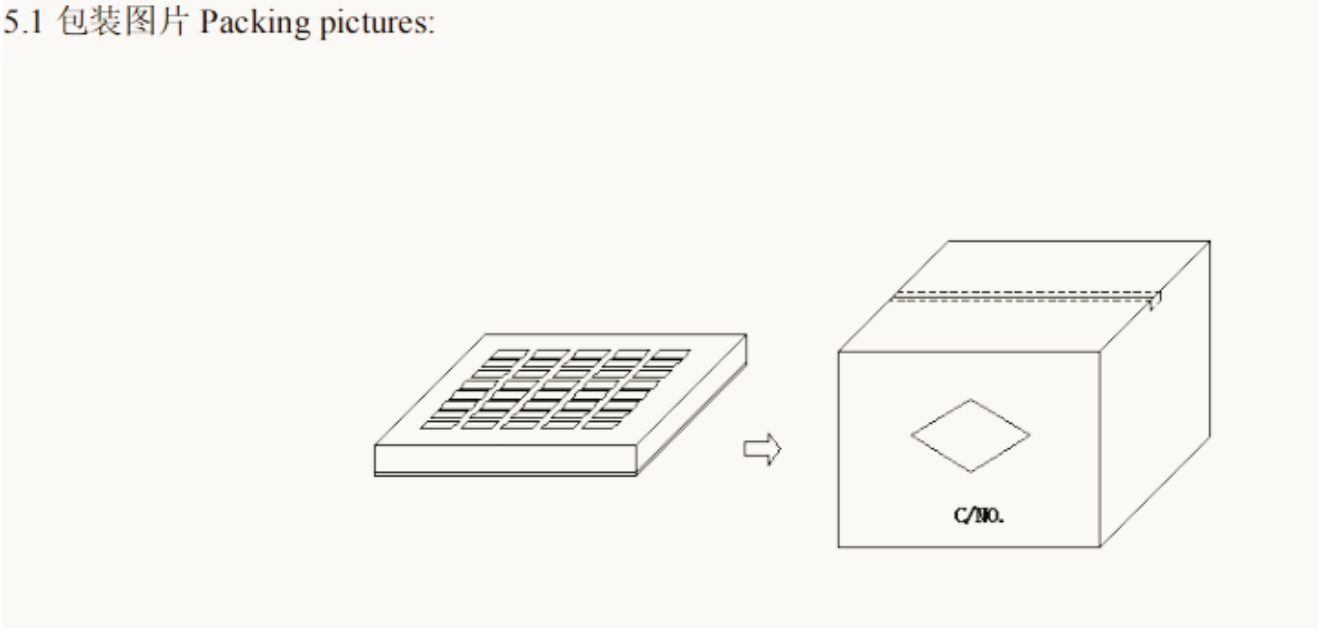

5.2 包装数量及规格 Packing Quantity:

项目 Item	数量 Quantity	材料规格 Material
盒 Box	350 Pcs	345*330*50 mm
箱 Big Carton	1400 Pcs	360*340*280 mm

5.3 *The packaging shall be based on the existing packing plate and the actual delivery package shall prevail .If there is any requirement,we can customize it.*