

Sample Information			
Product Code	Product Description	Reference(s) (Batch / Serial #)	Quantity
110A1000-01	Industrial Edge Machine	n/a	n/a
Notes / Comments			
Once the device has been assembled the RF circuit is not easily accessible or can be modified without the use of appropriate tools.			

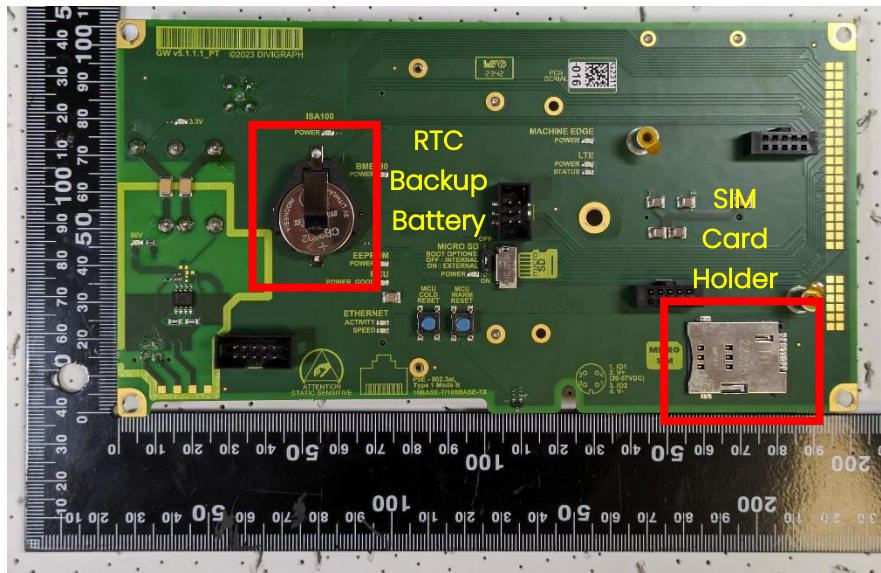

Figure 1 - Industrial Edge Machine - Main PCB - Top

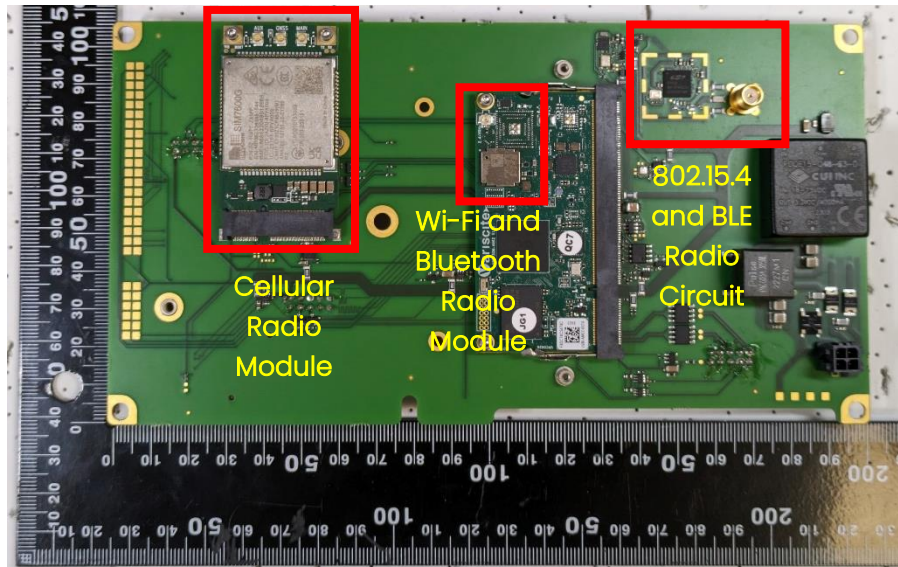

Figure 2 - Industrial Edge Machine - Main PCB - Bottom

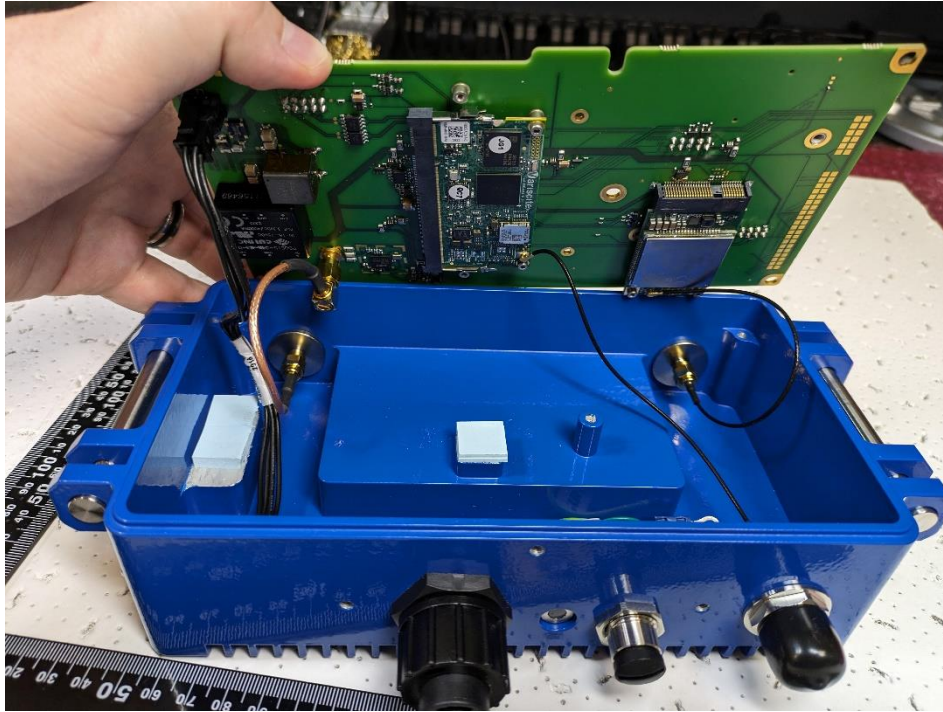

Figure 3 - Industrial Edge Machine - Internal RF Connection

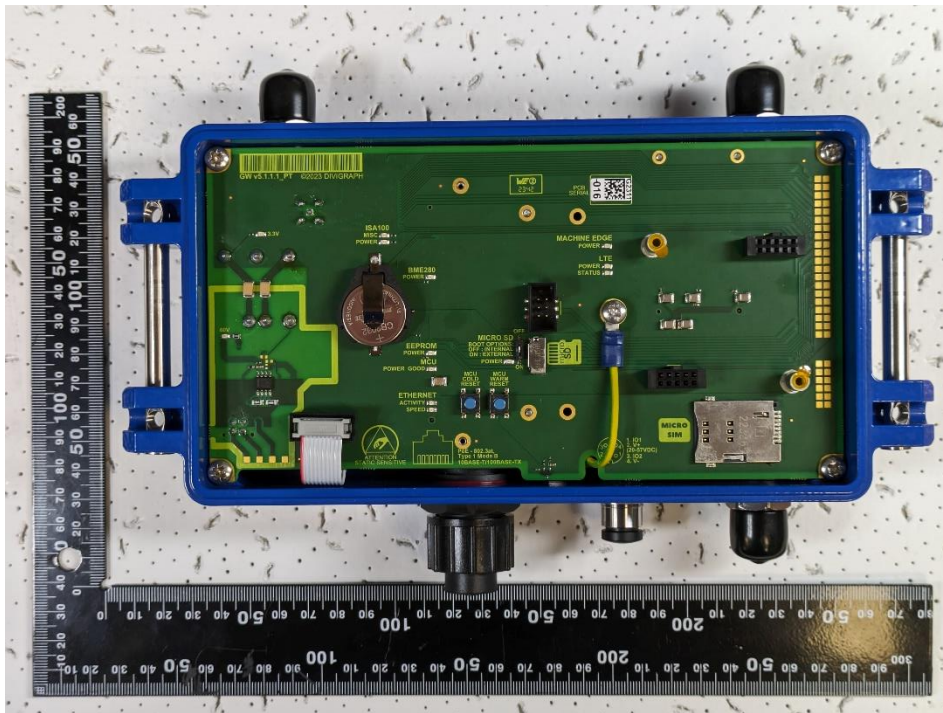

Figure 4 - Industrial Edge Machine - Internal Assembly

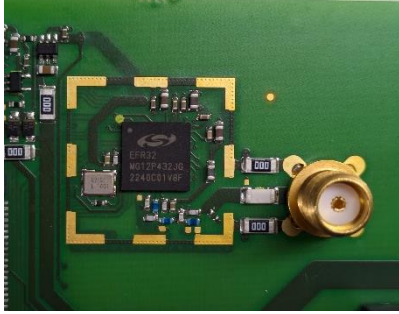

Figure 5 - Industrial Edge Machine – 802.15.4 and BLE Radio Circuit



Figure 7 - Industrial Edge Machine - Cellular Radio Module

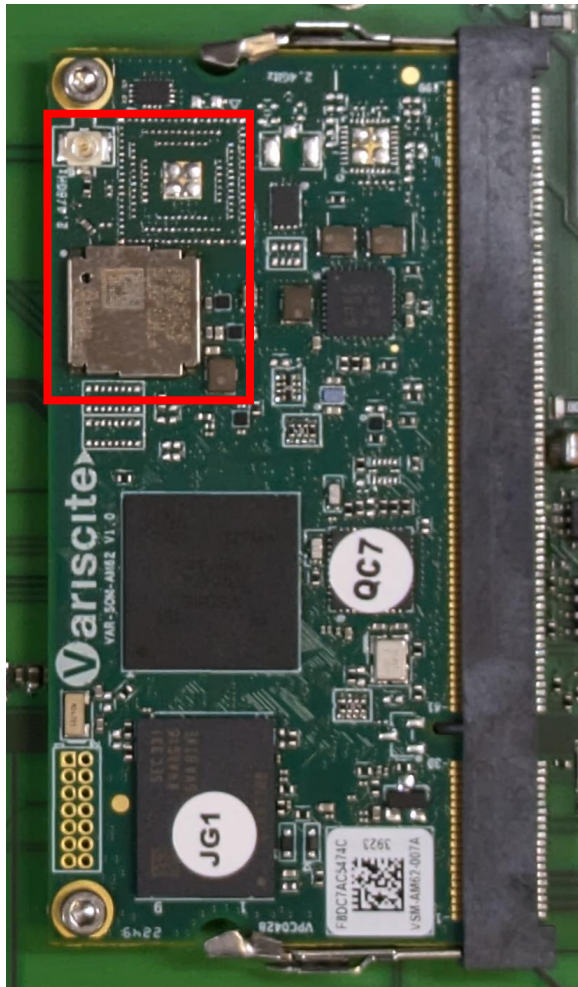

Figure 6 - Industrial Edge Machine - Wi-Fi and Bluetooth Radio Module



Figure 8 - Industrial Edge Machine - RTC Backup Battery