



TEST REPORT

Report Reference No...... : **TRE1803019702** R/C.....:35533

FCC ID..... : **2AO9X-UI410WC01**

Applicant's name..... : **Outform Science and Technology Ltd.**

Address..... : No. A103 Medical Appliance and Industry Garden,
#1019, Nanhai road, Nanshan district, Shenzhen 518035, China

Manufacturer..... : Outform Science and Technology Ltd.

Address..... : No. A103 Medical Appliance and Industry Garden,
#1019, Nanhai road, Nanshan district, Shenzhen 518035, China

Test item description : **MODULAR DEMO**

Trade Mark : **OUTFORM**

Model/Type reference..... : **UI410W-C01**

Listed Model(s) : **-**

Standard : **47 CFR FCC Part 15 Subpart B**

Date of receipt of test sample..... : **Mar.27, 2018**

Date of testing..... : **Mar.27, 2018- Apr.11, 2018**

Date of issue..... : **Apr.11, 2018**

Result..... : **Pass**

Compiled by
(position+printed name+signature)...: File administrators Fanghui Zhu

Supervised by
(position+printed name+signature)...: Project Engineer Jeff Sun

Approved by
(position+printed name+signature)...: RF Manager Hans Hu

Testing Laboratory Name : **Shenzhen Huatongwei International Inspection Co., Ltd.**

Address..... : 1/F, Bldg 3, Hongfa Hi-tech Industrial Park, Genyu Road, Tianliao,
Gongming, Shenzhen, China

Shenzhen Huatongwei International Inspection Co., Ltd. All rights reserved.

This publication may be reproduced in whole or in part for non-commercial purposes as long as the Shenzhen Huatongwei International Inspection Co., Ltd. is acknowledged as copyright owner and source of the material. Shenzhen Huatongwei International Inspection Co., Ltd. takes no responsibility for and will not assume liability for damages resulting from the reader's interpretation of the reproduced material due to its placement and context.

The test report merely correspond to the test sample.

Contents

1.	<u>TEST STANDARDS AND REPORT VERSION</u>	<u>3</u>
1.1.	Test Standards	3
1.2.	Report version	3
2.	<u>TEST DESCRIPTION</u>	<u>4</u>
3.	<u>SUMMARY.....</u>	<u>5</u>
3.1.	Client Information	5
3.2.	Product Description	5
3.3.	EUT operation mode	5
3.4.	Configuration of Tested System	5
3.5.	Support unit used in test configuration	6
4.	<u>TEST ENVIRONMENT</u>	<u>7</u>
4.1.	Address of the test laboratory	7
4.2.	Test Facility	7
4.3.	Environmental conditions	8
4.4.	Statement of the measurement uncertainty	8
4.5.	Equipments Used during the Test	9
5.	<u>TEST CONDITIONS AND RESULTS</u>	<u>10</u>
5.1.	Conducted Emissions Test	10
5.2.	Radiated Emissions Test	13
6.	<u>TEST SETUP PHOTOS OF THE EUT</u>	<u>17</u>
7.	<u>EXTERNAL AND INTERNAL PHOTOS OF THE EUT</u>	<u>18</u>

1. TEST STANDARDS AND REPORT VERSION

1.1. Test Standards

The tests were performed according to following standards:

[47 CFR FCC Part 15 Subpart B](#) - Unintentional Radiators

[ANSI C63.4: 2014](#) – American National Standard for Methods of Measurement of Radio-Noise Emissions from Low-Voltage Electrical and Electronic Equipment in the Range of 9 kHz to 40GHz

1.2. Report version

Version No.	Date of issue	Description
N/A	Apr.11, 2018	Original

2. TEST DESCRIPTION

Test Item	Section in CFR 47	Result	Test Engineer
Conducted Emissions	15.107(a)	Pass	Alex Guo
Radiated Emissions	15.109(a)	Pass	Shower dai

Note: The measurement uncertainty is not included in the test result.

3. SUMMARY

3.1. Client Information

Applicant:	Outform Science and Technology Ltd.
Address:	No. A103 Medical Appliance and Industry Garden, #1019, Nanhai road, Nanshan district, Shenzhen 518035, China
Manufacturer:	Outform Science and Technology Ltd.
Address:	No. A103 Medical Appliance and Industry Garden, #1019, Nanhai road, Nanshan district, Shenzhen 518035, China

3.2. Product Description

Name of EUT:	MODULAR DEMO
Trade Mark:	OUTFORM
Model No.:	UI410W-C01
Listed Model(s)	-
Power supply:	AC 120V/60Hz
Adapter information:	Model: EA10681N-160 Input: 100-240Va.c., 50/60Hz, 2.0A Output: 16Vd.c., 3.75A

3.3. EUT operation mode

Test mode	Describe
Charge	-
Playing	-
Data transmission	PC to EUT,EUT to PC.

3.4. Configuration of Tested System

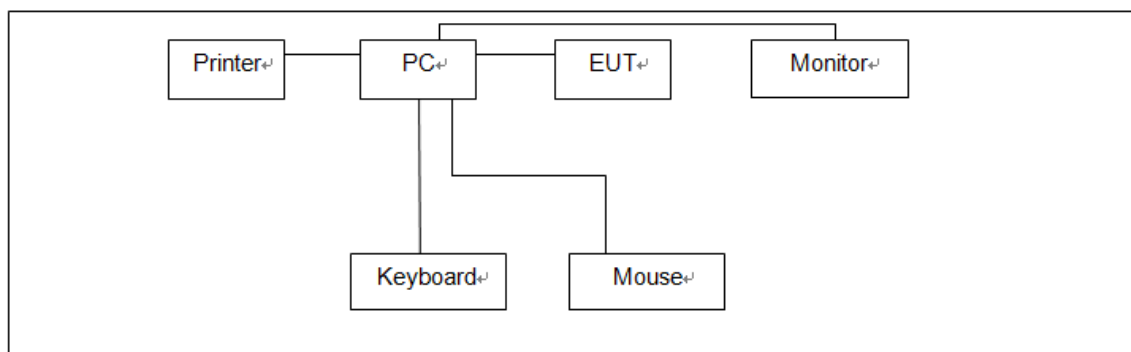

3.5. Support unit used in test configuration

Item	Equipment	Manufacturer	Model No.	FCC ID / FCC DoC	Data Cable	Power Cord
1	PC	DELL	OptiPlex 3020 MT	FCC DoC	N/A	Unshielded 1.8m
2	Monitor	DELL	E1912Hf	FCC DoC	N/A	Unshielded 1.8m
3	Keyboard	DELL	SK8115	FCC DoC	Unshielded, 1.5m	N/A
4	Mouse	DELL	MS111-T	FCC DoC	Unshielded, 1.5m	N/A
5	Printer	EPSON	L101	FCC DoC	N/A	Unshielded 1.8m

4. TEST ENVIRONMENT

4.1. Address of the test laboratory

Laboratory: Shenzhen Huatongwei International Inspection Co., Ltd.

Address: 1/F, Bldg 3, Hongfa Hi-tech Industrial Park, Genyu Road, Tianliao, Gongming, Shenzhen, China

Phone: 86-755-26748019 Fax: 86-755-26748089

4.2. Test Facility

The test facility is recognized, certified, or accredited by the following organizations:

CNAS-Lab Code: L1225

Shenzhen Huatongwei International Inspection Co., Ltd. has been assessed and proved to be in compliance with CNAS-CL01 Accreditation Criteria for Testing and Calibration Laboratories (identical to ISO/IEC17025: 2005 General Requirements) for the Competence of Testing and Calibration Laboratories.

A2LA-Lab Cert. No. 3902.01

Shenzhen Huatongwei International Inspection Co., Ltd. EMC Laboratory has been accredited by A2LA for technical competence in the field of electrical testing, and proved to be in compliance with ISO/IEC 17025: 2005 General Requirements for the Competence of Testing and Calibration Laboratories and any additional program requirements in the identified field of testing.

FCC-Registration No.: 762235

Shenzhen Huatongwei International Inspection Co., Ltd. EMC Laboratory has been registered and fully described in a report filed with the FCC (Federal Communications Commission). The acceptance letter from the FCC is maintained in our files. Registration 762235.

IC-Registration No.: 5377B-1

Two 3m Alternate Test Site of Shenzhen Huatongwei International Inspection Co., Ltd. has been registered by Certification and Engineering Bureau of Industry Canada for the performance of radiated measurements with Registration No. 5377B-1.

ACA

Shenzhen Huatongwei International Inspection Co., Ltd. EMC Laboratory can also perform testing for the Australian C-Tick mark as a result of our A2LA accreditation.

4.3. Environmental conditions

During the measurement the environmental conditions were within the listed ranges:

Temperature:	15~35°C
Relative Humidity:	30~60 %
Air Pressure:	950~1050mba

4.4. Statement of the measurement uncertainty

The data and results referenced in this document are true and accurate. The reader is cautioned that there may be errors within the calibration limits of the equipment and facilities. The measurement uncertainty was calculated for all measurements listed in this test report acc. to CISPR 16 - 4 „Specification for radio disturbance and immunity measuring apparatus and methods – Part 4: Uncertainty in EMC Measurements“ and is documented in the Shenzhen Huatongwei International Inspection Co., Ltd quality system acc. to DIN EN ISO/IEC 17025. Furthermore, component and process variability of devices similar to that tested may result in additional deviation. The manufacturer has the sole responsibility of continued compliance of the device.

Hereafter the best measurement capability for Shenzhen Huatongwei laboratory is reported:

Test	Range	Measurement Uncertainty	Notes
Radiated Emissions	30~1000MHz	4.24 dB	(1)
Radiated Emissions	1~18GHz	5.16 dB	(1)
Conducted Disturbance	0.15~30MHz	3.39 dB	(1)

(1) This uncertainty represents an expanded uncertainty expressed at approximately the 95% confidence level using a coverage factor of k=2.

4.5. Equipments Used during the Test

Conducted Emissions						
Item	Test Equipment	Manufacturer	Model No.	Serial No.	Last Cal. (mm-dd-yy)	Next Cal. (mm-dd-yy)
1	EMI Test Receiver	R&S	ESCI	101247	11/11/2017	11/10/2018
2	Artificial Mains	SCHWARZBECK	NNLK 8121	573	11/11/2017	11/10/2018
3	2-Line V-Network	R&S	ESH3-Z5	100049	11/11/2017	11/10/2018
4	Pulse Limiter	R&S	ESH3-Z2	101488	11/11/2017	11/10/2018
5	RF Connection Cable	HUBER+SUHNER	EF400	N/A	11/21/2017	11/20/2018
6	Test Software	R&S	ES-K1	N/A	N/A	N/A

Radiated Emissions						
Item	Test Equipment	Manufacturer	Model No.	Serial No.	Last Cal. (mm-dd-yy)	Next Cal. (mm-dd-yy)
1	Semi-Anechoic Chamber	Albatross projects	SAC-3m-01	C11121	10/16/2016	10/15/2019
2	EMI Test Receiver	R&S	ESCI	100900	11/11/2017	11/10/2018
3	Loop Antenna	R&S	HFH2-Z2	100020	11/20/2017	11/19/2020
4	Ultra-Broadband Antenna	SCHWARZBECK	VULB9163	538	4/5/2017	4/4/2020
5	Horn Antenna	SCHWARZBECK	9120D	1011	3/27/2017	3/26/2020
6	Broadband Horn Antenna	SCHWARZBECK	BBHA9170	BBHA9170 472	3/27/2017	3/26/2020
7	Pre-amplifier	SCHWARZBECK	BBV 9743	9743-0022	10/18/2017	10/17/2018
8	Broadband Pre-amplifier	SCHWARZBECK	BBV 9718	9718-248	10/18/2017	10/17/2018
9	Spectrum Analyzer	R&S	FSP40	100597	11/11/2017	11/10/2018
10	RF Connection Cable	HUBER+SUHNER	RE-7-FL	N/A	11/21/2017	11/20/2018
11	RF Connection Cable	HUBER+SUHNER	RE-7-FH	N/A	11/21/2017	11/20/2018
12	Test Software	Audix	E3	N/A	N/A	N/A
13	Test Software	R&S	ES-K1	N/A	N/A	N/A
14	Turntable	Maturo Germany	TT2.0-1T	N/A	N/A	N/A
15	Antenna Mast	Maturo Germany	CAM-4.0-P-12	N/A	N/A	N/A

5. TEST CONDITIONS AND RESULTS

5.1. Conducted Emissions Test

LIMIT

FCC CFR Title 47 Part 15 Subpart B Section 15.107:

Frequency range (MHz)	Limit (dBuV)	
	Quasi-peak	Average
0.15-0.5	66 to 56*	56 to 46*
0.5-5	56	46
5-30	60	50

* Decreases with the logarithm of the frequency.

TEST CONFIGURATION

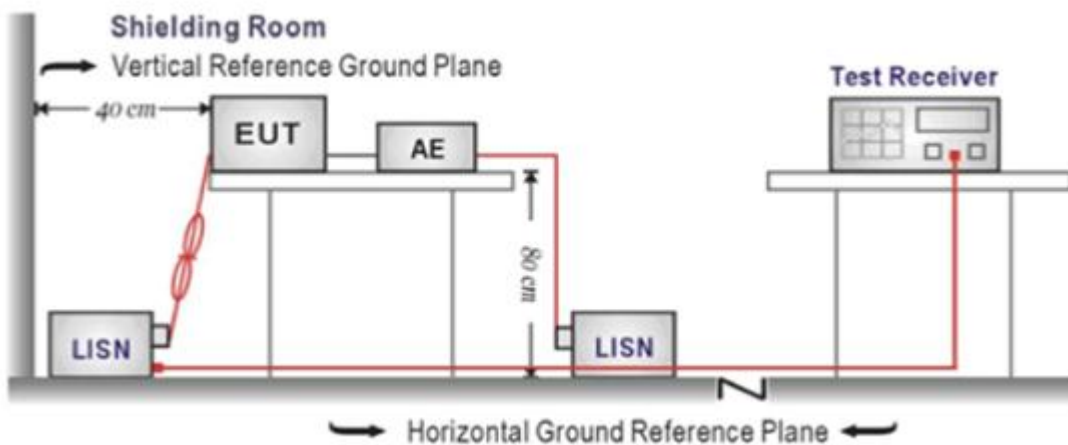

TEST PROCEDURE

1. The EUT was setup according to ANSI C63.4:2014
2. The EUT was placed on a plat form of nominal size, 1 m by 1.5 m, raised 10 cm above the conducting ground plane. The vertical conducting plane was located 40 cm to the rear of the EUT. All other surfaces of EUT were at least 10 cm from any other grounded conducting surface.
3. The EUT and simulators are connected to the main power through a line impedance stabilization network (LISN). The LISN provides a 50ohm / 50uH coupling impedance for the measuring equipment.
4. The peripheral devices are also connected to the main power through a LISN. (Please refer to the block diagram of the test setup and photographs)
5. Each current-carrying conductor of the EUT power cord, except the ground (safety) conductor, was individually connected through a LISN to the input power source.
6. The excess length of the power cord between the EUT and the LISN receptacle were folded back and forth at the center of the lead to form a bundle not exceeding 40 cm in length.
7. Conducted emissions were investigated over the frequency range from 0.15MHz to 30MHz using a receiver bandwidth of 9 kHz.
8. During the above scans, the emissions were maximized by cable manipulation.

TEST MODE:

Please refer to the clause 3.3

TEST RESULTS

Passed Not Applicable

Test Line:

L

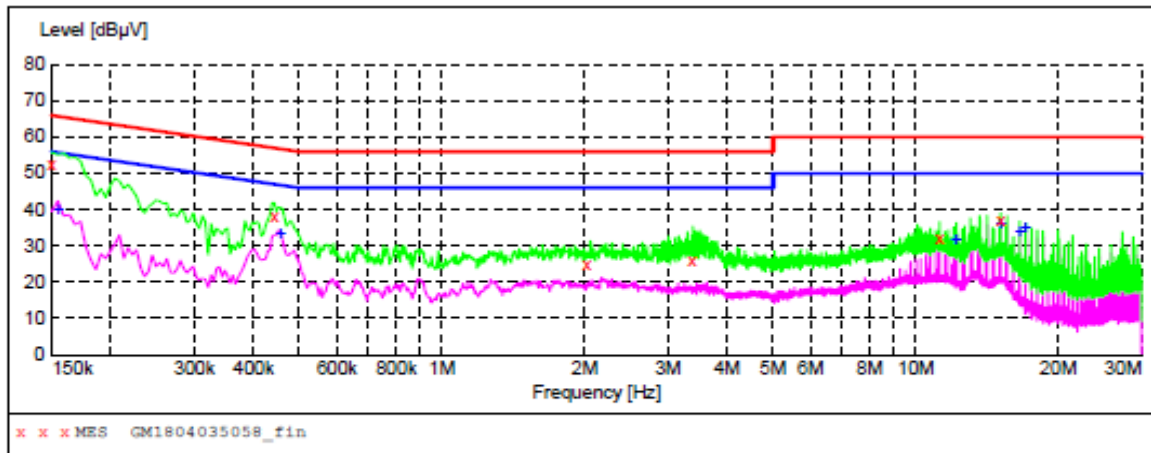

MEASUREMENT RESULT: "GM1804035058_fin"

4/3/2018 4:07PM

Frequency MHz	Level dBµV	Transd dB	Limit dBµV	Margin dB	Detector	Line	PE
0.150000	52.40	10.0	66	13.6	QP	L1	GND
0.442500	38.10	9.9	57	18.9	QP	L1	GND
2.017500	24.60	10.1	56	31.4	QP	L1	GND
3.367500	25.70	10.1	56	30.3	QP	L1	GND
11.229000	32.30	10.4	60	27.7	QP	L1	GND
15.130500	37.20	10.5	60	22.8	QP	L1	GND

MEASUREMENT RESULT: "GM1804035058_fin2"

4/3/2018 4:07PM

Frequency MHz	Level dBµV	Transd dB	Limit dBµV	Margin dB	Detector	Line	PE
0.154500	40.20	10.0	56	15.6	AV	L1	GND
0.456000	33.80	9.9	47	13.0	AV	L1	GND
12.201000	32.00	10.5	50	18.0	AV	L1	GND
15.130500	36.30	10.5	50	13.7	AV	L1	GND
16.597500	34.50	10.5	50	15.5	AV	L1	GND
17.083500	35.50	10.6	50	14.5	AV	L1	GND

Test Line:

N

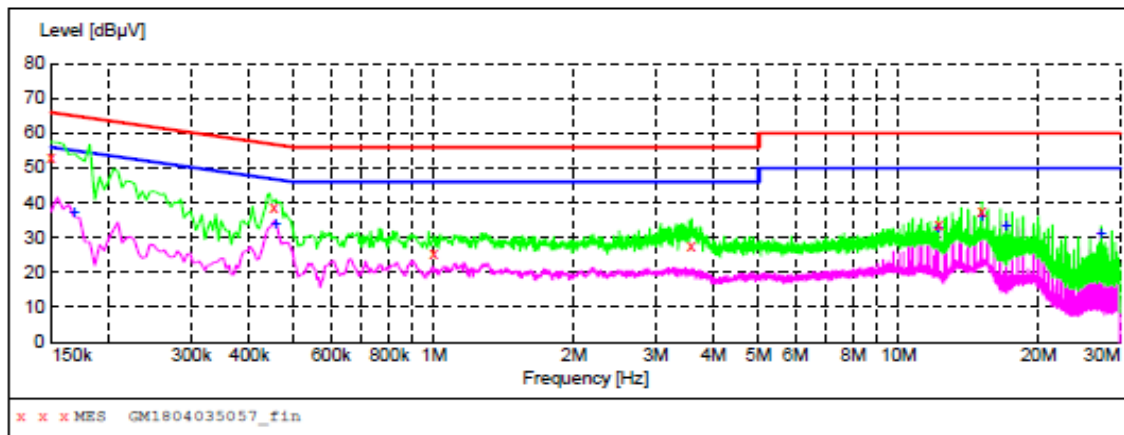

MEASUREMENT RESULT: "GM1804035057_fin"

4/3/2018 4:04PM

Frequency MHz	Level dBµV	Transd dB	Limit dBµV	Margin dB	Detector	Line	PE
0.150000	53.20	10.0	66	12.8	QP	N	GND
0.451500	38.80	9.9	57	18.0	QP	N	GND
1.000500	25.40	10.1	56	30.6	QP	N	GND
3.574500	27.50	10.1	56	28.5	QP	N	GND
12.196500	33.90	10.5	60	26.1	QP	N	GND
15.126000	37.50	10.5	60	22.5	QP	N	GND

MEASUREMENT RESULT: "GM1804035057_fin2"

4/3/2018 4:04PM

Frequency MHz	Level dBµV	Transd dB	Limit dBµV	Margin dB	Detector	Line	PE
0.168000	37.30	10.0	55	17.8	AV	N	GND
0.456000	34.20	9.9	47	12.6	AV	N	GND
12.196500	32.90	10.5	50	17.1	AV	N	GND
15.126000	36.30	10.5	50	13.7	AV	N	GND
17.074500	33.70	10.6	50	16.3	AV	N	GND
27.325500	31.40	10.8	50	18.6	AV	N	GND

5.2. Radiated Emissions Test

LIMIT

FCC CFR Title 47 Part 15 Subpart B Section 15.209

Frequency	Limit (dBuV/m @3m)	Value
30MHz-88MHz	40.00	Quasi-peak
88MHz-216MHz	43.50	Quasi-peak
216MHz-960MHz	46.00	Quasi-peak
960MHz-1GHz	54.00	Quasi-peak
Above 1GHz	54.00	Average
	74.00	Peak

TEST CONFIGURATION

➤ 30MHz ~ 1GHz

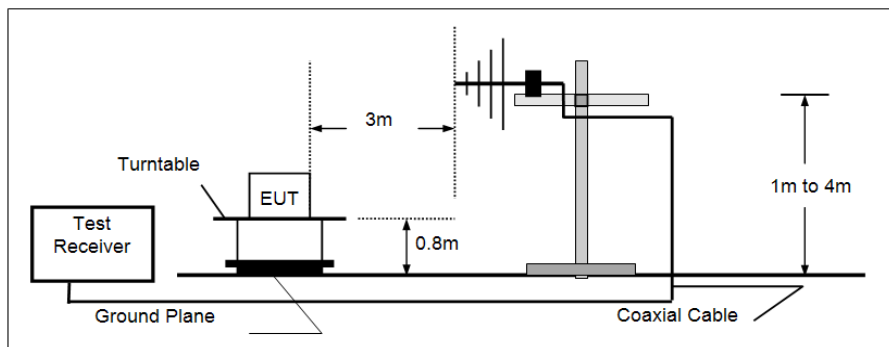

➤ Above 1GHz

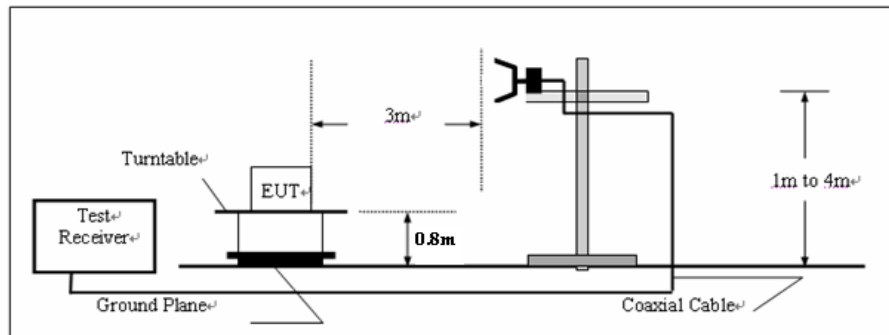

TEST PROCEDURE

1. The EUT was tested according to ANSI C63.4:2014.
2. The EUT is placed on a turn table which is 0.8 meter above ground.
3. The turn table is rotated 360 degrees to determine the position of the maximum emission level.
4. The EUT was positioned such that the distance from antenna to the EUT was 3 meters.
5. The antenna is scanned from 1 meter to 4 meters to find out the maximum emission level. This is repeated for both horizontal and vertical polarization of the antenna.
6. Use the following spectrum analyzer settings
 - (1) Span shall wide enough to fully capture the emission being measured;
 - (2) Below 1GHz,
RBW=120KHz, VBW=300KHz, Sweep=auto, Detector function=peak, Trace=max hold;
If the emission level of the EUT measured by the peak detector is 3 dB lower than the applicable limit, the peak emission level will be reported. Otherwise, the emission measurement will be repeated using the quasi-peak detector and reported.
 - (3) From 1GHz to 5th harmonic, RBW=1MHz, VBW=3MHz

TEST MODE:

Please refer to the clause 3.3

TEST RESULTS

Passed **Not Applicable**

Note: Final Level =Receiver Read level + Antenna Factor + Cable Loss – Preamplifier Factor

Test from 30MHz to 25GHz , only report worse case from 30MHz to 6GHz , for above 6GHz , no emission found

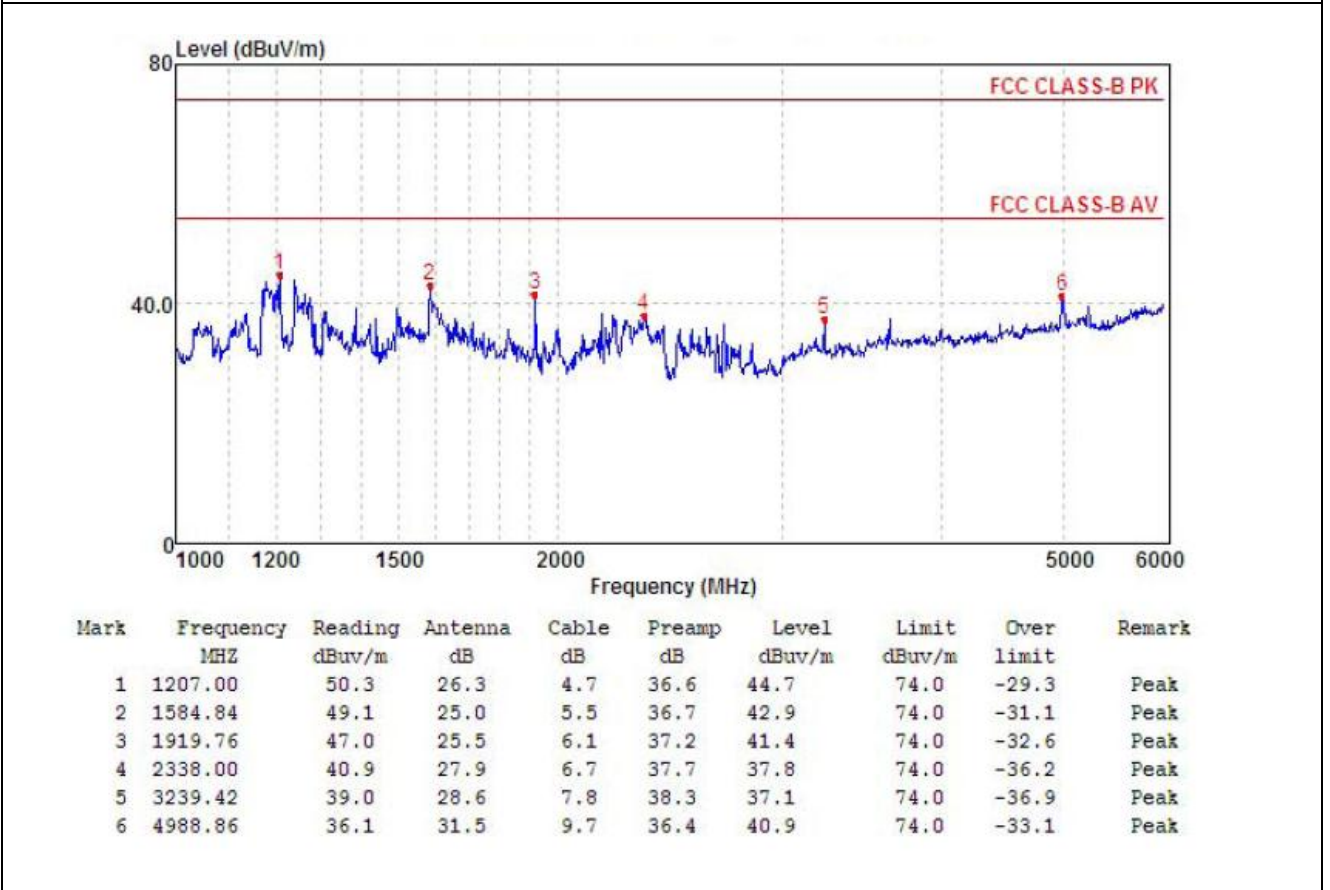
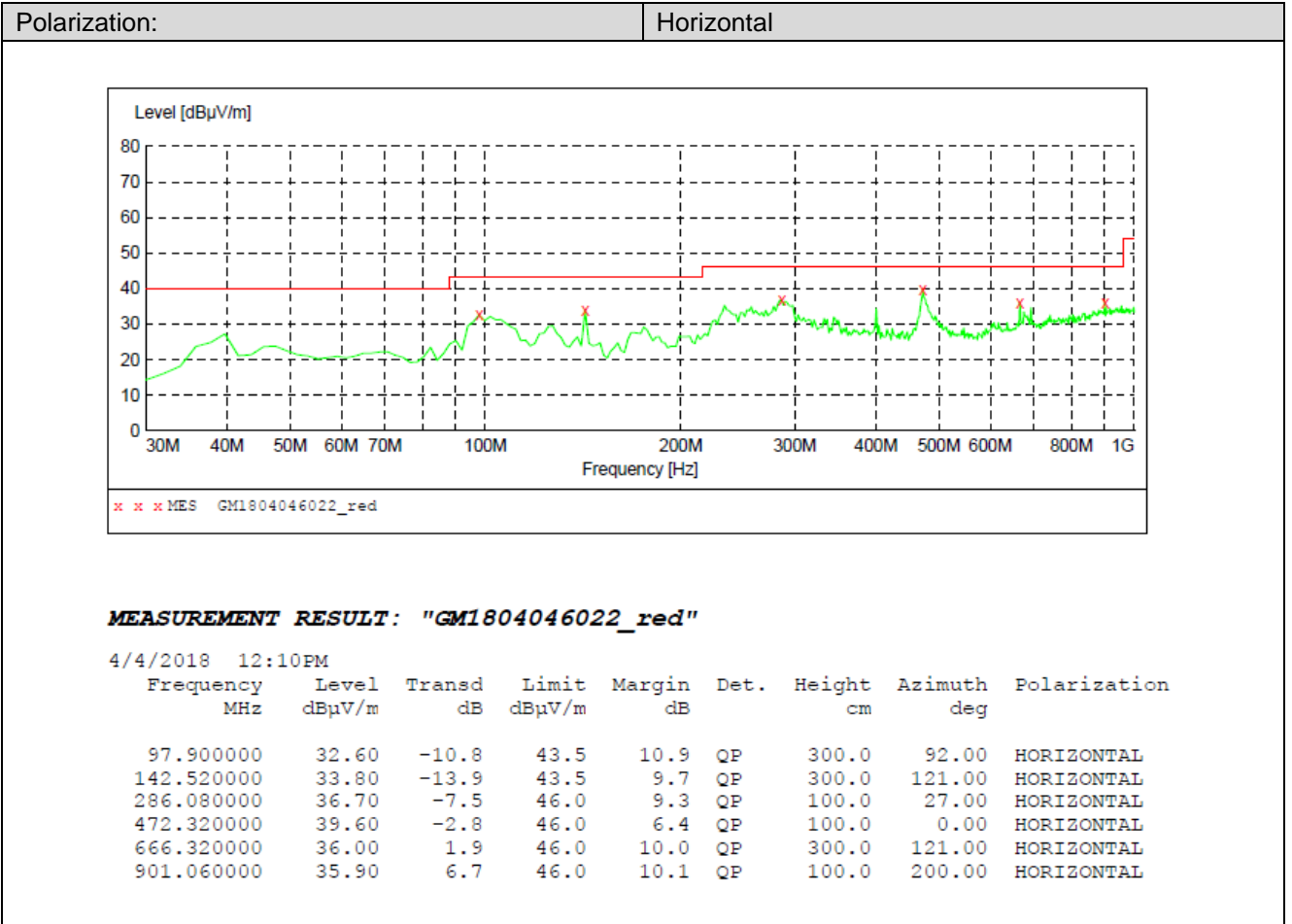

Polarization: Vertical

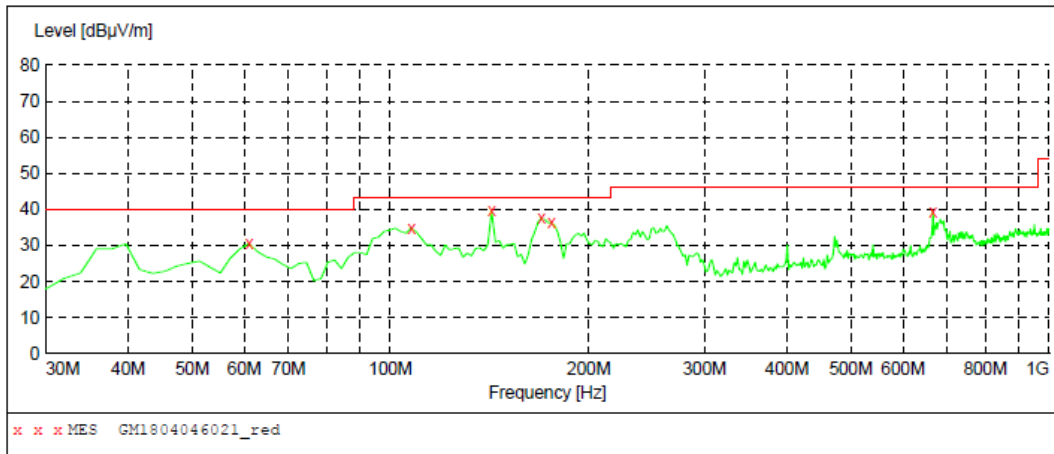

MEASUREMENT RESULT: "GM1804046021_red"

4/4/2018 12:06PM

Frequency MHz	Level dBuV/m	Transd dB	Limit dBuV/m	Margin dB	Det.	Height cm	Azimuth deg	Polarization
61.040000	30.60	-10.3	40.0	9.4	QP	100.0	360.00	VERTICAL
107.600000	34.90	-10.6	43.5	8.6	QP	100.0	14.00	VERTICAL
142.520000	39.50	-13.9	43.5	4.0	QP	100.0	281.00	VERTICAL
169.680000	37.50	-13.0	43.5	6.0	QP	100.0	0.00	VERTICAL
175.500000	36.30	-12.7	43.5	7.2	QP	100.0	14.00	VERTICAL
666.320000	39.20	1.9	46.0	6.8	QP	100.0	213.00	VERTICAL

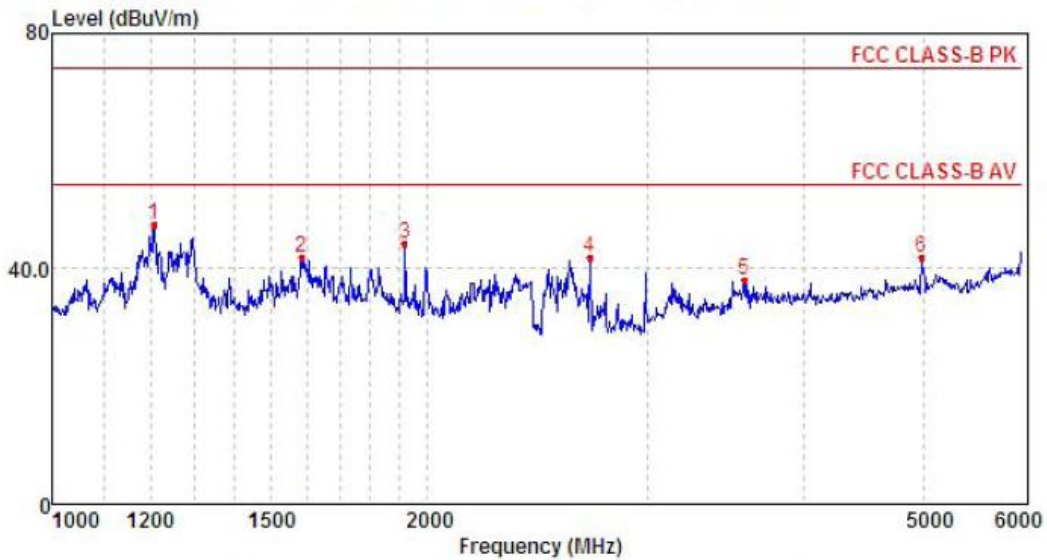

Mark	Frequency MHz	Reading dBuV/m	Antenna dB	Cable dB	Preamp dB	Level dBuV/m	Limit dBuV/m	Over limit	Remark
1	1207.00	53.0	26.3	4.7	36.6	47.4	74.0	-26.6	Peak
2	1584.84	47.8	25.0	5.5	36.7	41.6	74.0	-32.4	Peak
3	1919.76	49.6	25.5	6.1	37.2	44.0	74.0	-30.0	Peak
4	2698.33	44.4	28.1	7.1	38.1	41.5	74.0	-32.5	Peak
5	3587.75	38.5	29.3	8.3	38.3	37.8	74.0	-36.2	Peak
6	4979.93	36.9	31.5	9.7	36.5	41.6	74.0	-32.4	Peak

6. TEST SETUP PHOTOS OF THE EUT

Conducted Emissions (AC Mains)



Radiated Emissions (30MHz-1GHz)



Radiated Emissions (Above 1GHz)

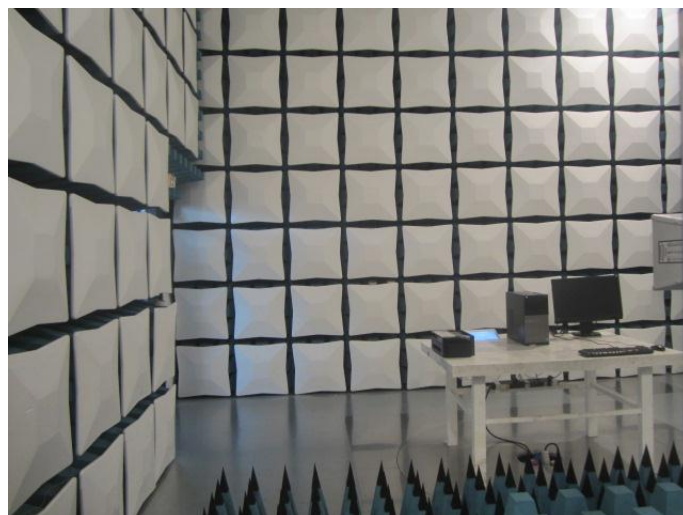

7. EXTERNAL AND INTERNAL PHOTOS OF THE EUT

Reference to the test report No.: TRE1803019701

-----End of Report-----