



**DATE: 23 September 2018**

**I.T.L. (PRODUCT TESTING) LTD.**

**FCC Radio Test Report**

for

**Neurolief Ltd.**

Equipment under test:

**Relivion**

**RLV3**

Tested by: \_\_\_\_\_

  
M. Zohar

Approved by: \_\_\_\_\_

  
D. Shidlovsky

This report must not be reproduced, except in full, without the written permission of I.T.L. (Product Testing) Ltd.

This report relates only to items tested.



# Measurement/Technical Report for Neurolief Ltd.

Relivion

RLV3

FCC ID: 2AO9M-01

This report concerns:	Original Grant: X
	Class I Change:
	Class II Change:
Equipment type:	Digital Transmission System
Limits used:	47CFR15 Section 15.247

Measurement procedure used is KDB 558074 D01 v04, ANSI C63.10:2013

Application for Certification prepared by:	Applicant for this device: (different from "prepared by")
R. Pinchuck	Amit Dar
ITL (Product Testing) Ltd.	Neurolief Ltd.
1 Bat Sheva St.	12 Giborei Israel Street
Lod 7116002	Netanya, 4250412 Israel
e-mail Rpinchuck@itlglobal.org	Tel: + 972 -54-4900914
	Email: Amit.dar@neurolief.com



# TABLE OF CONTENTS

<b>1.</b>	<b>GENERAL INFORMATION</b>	<b>5</b>
1.1	Administrative Information	5
1.2	List of Accreditations	6
1.3	Product Description	7
1.4	Test Methodology	7
1.5	Test Facility	8
1.6	Measurement Uncertainty	8
<b>2.</b>	<b>SYSTEM TEST CONFIGURATION</b>	<b>9</b>
2.1	Justification	9
2.2	EUT Exercise Software	9
2.3	Special Accessories	9
2.4	Equipment Modifications	10
2.5	Configuration of Tested System	10
<b>3.</b>	<b>CONDUCTED &amp; RADIATED MEASUREMENT TEST SET-UP PHOTOS</b>	<b>11</b>
<b>4.</b>	<b>CONDUCTED EMISSION FROM AC MAINS</b>	<b>14</b>
4.1	Test Specification	14
4.2	Test Procedure	14
4.3	Test Limit	14
4.4	Test Results	15
4.5	Test Equipment Used; Conducted Emission	20
<b>5.</b>	<b>6 DB MINIMUM BANDWIDTH</b>	<b>21</b>
5.1	Test Specification	21
5.2	Test Procedure	21
5.3	Test Limit	21
5.4	Test Results	21
5.5	Test Equipment Used; 6dB Bandwidth	23
<b>6.</b>	<b>MAXIMUM TRANSMITTED PEAK POWER OUTPUT</b>	<b>24</b>
6.1	Test Specification	24
6.2	Test Procedure	24
6.3	Test Limit	24
6.4	Test Results	25
6.5	Test Equipment Used; Maximum Peak Power Output	28
<b>7.</b>	<b>BAND EDGE SPECTRUM</b>	<b>29</b>
7.1	Test Specification	29
7.2	Test Procedure	29
7.3	Test Limit	29
7.4	Test Results	29
7.5	Test Equipment Used; Band Edge Spectrum	31
<b>8.</b>	<b>EMISSIONS IN NON-RESTRICTED FREQUENCY BANDS</b>	<b>32</b>
8.1	Test Specification	32
8.2	Test Procedure	32
8.3	Test Limit	32
8.4	Test Results	32
8.5	Test Instrumentation Used, Emission in Non Restricted Frequency Bands	33
8.6	Field Strength Calculation	34
<b>9.</b>	<b>EMISSIONS IN RESTRICTED FREQUENCY BANDS</b>	<b>35</b>
9.1	Test Specification	35
9.2	Test Procedure	35
9.3	Test Limit	36
9.4	Test Results	36
9.5	Test Instrumentation Used; Emissions in Restricted Frequency Bands	38



<b>10.</b>	<b>TRANSMITTED POWER DENSITY -----</b>	<b>39</b>
10.1	Test Specification .....	39
10.2	Test Procedure .....	39
10.3	Test Limit .....	39
10.4	Test Results.....	39
10.5	Test Equipment Used; Transmitted Power Density .....	41
<b>11.</b>	<b>ANTENNA GAIN/INFORMATION-----</b>	<b>42</b>
<b>12.</b>	<b>R.F EXPOSURE/SAFETY-----</b>	<b>43</b>
<b>13.</b>	<b>APPENDIX A - CORRECTION FACTORS -----</b>	<b>44</b>
13.1	Correction factors for RF OATS Cable 35m ITL #1911 .....	44
13.2	Correction factor for RF CABLE for Semi Anechoic Chamber.....	45
13.3	Correction factors for Active Loop Antenna .....	46
13.4	Correction factors for biconical antenna – ITL # 1356 .....	47
13.5	Correction factors for log periodic antenna – ITL # 1349.....	48
13.6	Correction factors for Double –Ridged Waveguide Horn ANTENNA.....	49
13.7	Correction factors for Horn Antenna .....	50



# 1. General Information

## 1.1 Administrative Information

Manufacturer:	Neurolief Ltd.
Manufacturer's Address:	12 Girborei Israel Street Netanya, 4250412, Israel Tel: +972-54-4900914 Email: Amit.dar@neurolief.com
Manufacturer's Representative:	Amit Dar
Equipment Under Test (E.U.T):	Relivion
Equipment Model No.:	RLV3
Equipment Serial No.:	R03182100003
Date of Receipt of E.U.T:	June 17, 2018
Start of Test:	June 17, 2018
End of Test:	June 21, 2018
Test Laboratory Location:	I.T.L (Product Testing) Ltd. 1 Batsheva St., Lod ISRAEL 7120101
Test Specifications:	FCC Part 15, Subpart C



## **1.2 List of Accreditations**

The EMC laboratory of I.T.L. is accredited by the following bodies:

1. The American Association for Laboratory Accreditation (A2LA) (U.S.A.), Certificate No. 1152.01.
2. The Federal Communications Commission (FCC) (U.S.A.), FCC Designation No. IL1005.
3. The Israel Ministry of the Environment (Israel), Registration No. 1104/01.
4. Industry Canada (Canada), IC File No.: 46405-4025; Site Nos. IC 4025A-1, IC 4025A-2.

I.T.L. Product Testing Ltd. is accredited by the American Association for Laboratory Accreditation (A2LA) and the results shown in this test report have been determined in accordance with I.T.L.'s terms of accreditation unless stated otherwise in the report.



### 1.3 **Product Description**

The Relivion™ is an external neurostimulator designed for transcutaneous electrical nerve stimulation. The headset integrates three pairs of output electrodes which come in contact with the subject scalp at the forehead (two pairs) and occiput (1 pair). The electrodes deliver the stimulation pulses produced by the stimulation unit to the subject's scalp. Stimulation intensity can be adjusted by the user. The Relivion™ is a prescription device that will be self-used in a home environment.

The device is comprised of a headset with integrated electrodes, designed to enable stimulation of the target nerves. The on-board stimulation circuit is adapted to deliver stimulation patterns to enhance proper nerve activation. The headset adjusts to various head sizes and contours and can be worn comfortably.

The Relivion™ incorporates an on-board interface that enables the user to activate/deactivate the device and to adjust the stimulation intensity. It also provides visual and auditory indications such as whether the device is active/non-active and when there is a low battery.

The Relivion™ can communicate via a low energy Bluetooth link with a mobile application on the user's smartphone. The mobile application displays the device status and provides indications such as treatment intensity level, treatment duration, low battery, charging state, etc. The mobile application is optional as the Relivion™ can be fully operated without it. Furthermore, the device cannot be controlled (activate, adjust intensity, etc.) by the mobile application.

Model name	RLV3
Working voltage	3.7VDC Rechargeable battery operated via AC/DC adapter
Mode of operation	Transceiver
Modulations	GFSK
Assigned Frequency Range	2400.0-2483.5MHz
Operating Frequency Range	2402.0-2480.0MHz
Transmit power(conducted)	~7.0dBm(step level by software GUI)
Antenna Gain	+0.5dBi (Peak) chip antenna
Modulation BW	2MHz
Bit rate (Mbit/s)	1

### 1.4 **Test Methodology**

Both conducted and radiated testing was performed according to the procedures in KDB 558074 D01 v04 and ANSI C63.10: 2013. Radiated testing was performed at an antenna to EUT distance of 3 meters.



## **1.5 Test Facility**

Emissions tests were performed at I.T.L.'s testing facility in Lod, Israel. I.T.L.'s EMC Laboratory is accredited by A2LA, certificate No. 1152.01 and its FCC Designation Number is IL1005.

## **1.6 Measurement Uncertainty**

### **Radiated Emission**

Radiated Emission (CISPR 11, EN 55011, CISPR 22, EN 55022, ANSI C63.4)  
for open site:

30-1000MHz:

Expanded Uncertainty (95% Confidence, K=2):

± 4.96 dB

1 GHz to 6 GHz

Expanded Uncertainty (95% Confidence, K=2):

±5.19 dB

>6 GHz

Expanded Uncertainty (95% Confidence, K=2):

±5.51 dB



## 2. System Test Configuration

### 2.1 Justification

1. The E.U.T contains transceiver IEEE 802.15.1 standard (BLE).
2. The unit was evaluated while transmitting at the low channel (2402MHz), the mid channel (2440MHz) and the high channel (2480MHz).
3. The evaluation was performed with the E.U.T connected to typical AC/DC adapter in charge mode as the “worst case”.
4. Final radiated emission tests was performed after exploratory emission testing that was performed in 3 orthogonal polarities to determine the “worst case” radiation. Per the table below the worst case was the Z axis.

Orientation	Frequency (MHz)	Field Strength (dBuV/m)	2nd Harmonic (dBuV/m)	3rd Harmonic (dBuV/m)	Band Edge (dBuV/m)
X axis	2402.0	89.9	49.7	47.0	69.5
	2440.0	87.8	45.5	46.8	-
	2480.0	86.1	44.8	47.2	63.0
Y axis	2402.0	89.5	45.2	47.0	71.1
	2440.0	88.3	44.9	47.0	-
	2480.0	86.7	44.3	46.8	63.1
Z axis	2402.0	<b>90.2</b>	45.9	47.1	69.6
	2440.0	<b>90.5</b>	45.7	47.0	-
	2480.0	<b>87.7</b>	45.1	47.4	62.8

Figure 1. Screening Results

### 2.2 EUT Exercise Software

ST BLUENRG\_GUI V 2.6.0 with step size power.

### 2.3 Special Accessories

#### Laptop details:

Manufacturer: Lenovo

Model: 80XF

S/N: P201TZ6Z

#### AC/DC charger details:

Manufacturer: N/A

Model: SAW06B-050-1000G

S/N: N/A

## 2.4 *Equipment Modifications*

No modifications were necessary in order to achieve compliance.

## 2.5 *Configuration of Tested System*

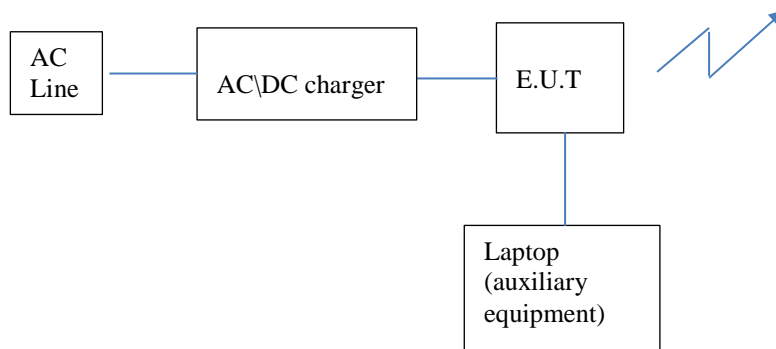

**Figure 2. Configuration of Tested System**

### 3. Conducted & Radiated Measurement Test Set-Up Photos

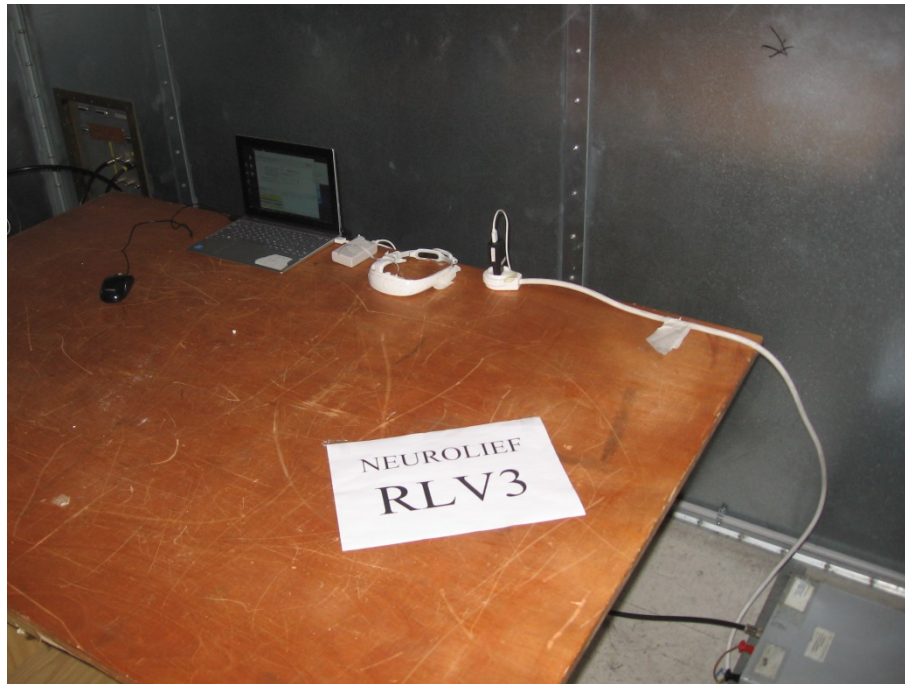

Figure 3. Conducted Emission from AC Line Test

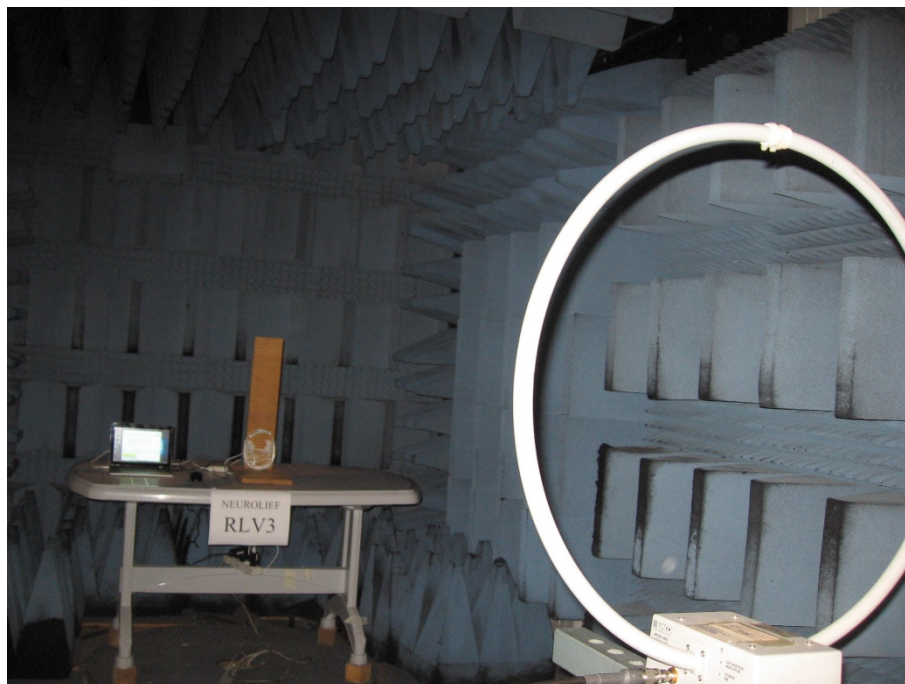

Figure 4. Radiated Emission Test, 0.009-30MHz



**Figure 5. Radiated Emission Test, 30-200MHz**



**Figure 6. Radiated Emission Test, 200-1000MHz**

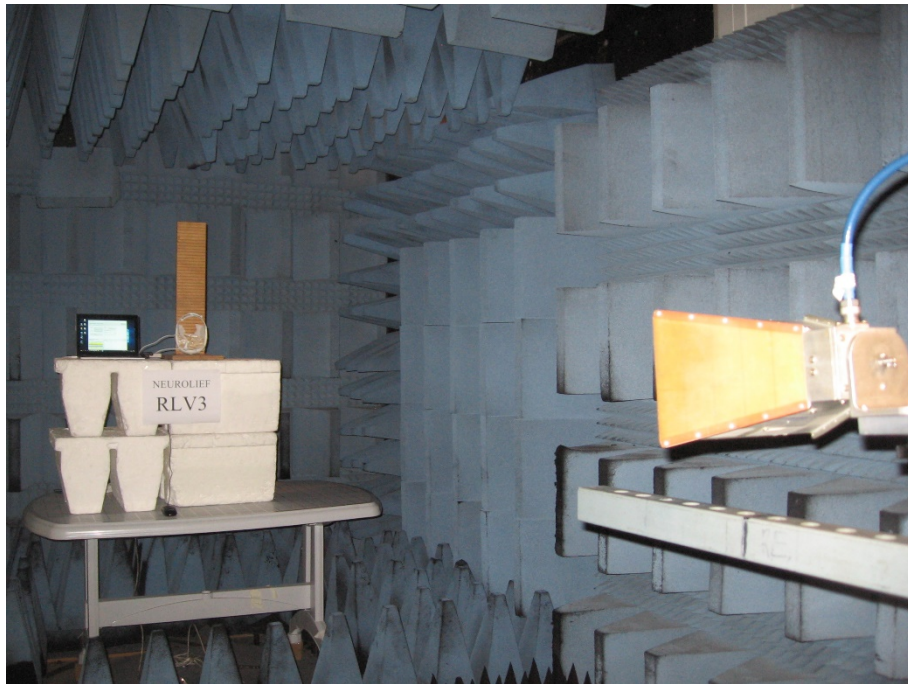

**Figure 7. Radiated Emission Test, 1-18GHz**



**Figure 8. Radiated Emission Test, 18-26.5GHz**

## 4. Conducted Emission From AC Mains

### 4.1 Test Specification

FCC Part 15, Subpart C, Section 15.207

### 4.2 Test Procedure

(Temperature (22°C)/ Humidity (55%RH))

The E.U.T operation mode and test setup are as described in Section 2 of this report. In order to minimize background noise interference, the conducted emission testing was performed inside a shielded room, with the E.U.T placed on a 0.8 meter high wooden table, 0.4 meter from the room's vertical wall. In the case of a floor-standing E.U.T., it was placed on the horizontal ground plane.

The E.U.T was powered from 115 V AC / 60 Hz via 50 Ohm / 50  $\mu$ Hn Line Impedance Stabilization Network (LISN) on the phase and neutral lines. The LISN's were grounded to the shielded room ground plane (floor), and were kept at least 0.8 meters from the nearest boundary of the E.U.T

The center of the E.U.T.'s AC cable was folded back and forth, in order to form a bundle less than 0.40 meters and a total cable length of 1 meter.

The effect of varying the position of the cables was investigated to find the configuration that produces maximum emission.

The emission voltages at the LISN's outputs were measured using a computerized receiver, complying with CISPR 16 requirements. The specification limits are loaded to the receiver and are displayed on the receiver's spectrum display.

The E.U.T was evaluated in TX operation mode.

A frequency scan between 0.15 and 30 MHz was performed at 9 kHz I.F. band width, using peak detection.

The spectral components having the highest level on each line were measured using a quasi-peak and average detector.

### 4.3 Test Limit

Frequency of emission (MHz)	Conducted limit (dB $\mu$ V)	
	Quasi-peak	Average
0.15-0.5	66 to 56*	56 to 46*
0.5-5	56	46
5-30	60	50

\* Decreases with the logarithm of the frequency.



#### 4.4 **Test Results**

JUDGEMENT: Passed by 12.79 dB

The margin between the emission levels and the specification limit is, in the worst case, 6.13 dB for the phase line at 0.422 MHz and 12.42 dB at 0.422 MHz for the neutral line.

The EUT met the F.C.C. Part 15, Subpart C specification requirements.

The details of the highest emissions are given in *Figure 9* to *Figure 12*.



## Conducted Emission

E.U.T Description Relivion  
Type RLV3  
Serial Number: R03182100003

Specification: FCC Part 15, Subpart C  
Lead: Phase  
Detectors: : Peak, Quasi-peak, Average  
Power Operation AC/DC charger

EDIT PEAK LIST (Final Measurement Results)			
TRACE	FREQUENCY	LEVEL dBμV	DELTA LIMIT dB
Trace1:	CE22BQP		
Trace2:	CE22BAP		
Trace3:	---		
2 Average	150 kHz	41.58	-14.41
1 Quasi Peak	154 kHz	53.20	-12.57
1 Quasi Peak	422 kHz	46.36	-11.04
2 Average	422 kHz	41.27	-6.13
2 Average	434 kHz	35.76	-11.40
1 Quasi Peak	462 kHz	40.20	-16.44
2 Average	742 kHz	29.91	-16.08
1 Quasi Peak	902 kHz	35.96	-20.03
2 Average	1.566 MHz	28.41	-17.58
1 Quasi Peak	2.022 MHz	34.44	-21.55
2 Average	2.134 MHz	28.74	-17.25
1 Quasi Peak	3.402 MHz	34.08	-21.91
2 Average	3.962 MHz	26.78	-19.21
1 Quasi Peak	4.518 MHz	34.82	-21.17
2 Average	7.454 MHz	20.79	-29.20
1 Quasi Peak	9.95 MHz	28.76	-31.24
1 Quasi Peak	15.894 MHz	37.06	-22.93
2 Average	15.898 MHz	27.77	-22.22
1 Quasi Peak	17.858 MHz	29.23	-30.76
2 Average	24.046 MHz	34.29	-15.70

Date: 21.JUN.2018 12:23:49

**Figure 9. Detectors: Peak, Quasi-peak, Average**

*Note: QP Delta/Av Delta refers to the test results obtained minus specified requirement; thus a positive number indicates failure, and a negative result indicates that the product passes the test.*





# Conducted Emission

E.U.T Description Relivion  
Type RLV3  
Serial Number: R03182100003

Specification: FCC Part 15, Subpart C  
Lead: Phase  
Detectors: Peak, Quasi-peak, Average  
Power Operation AC/DC charger

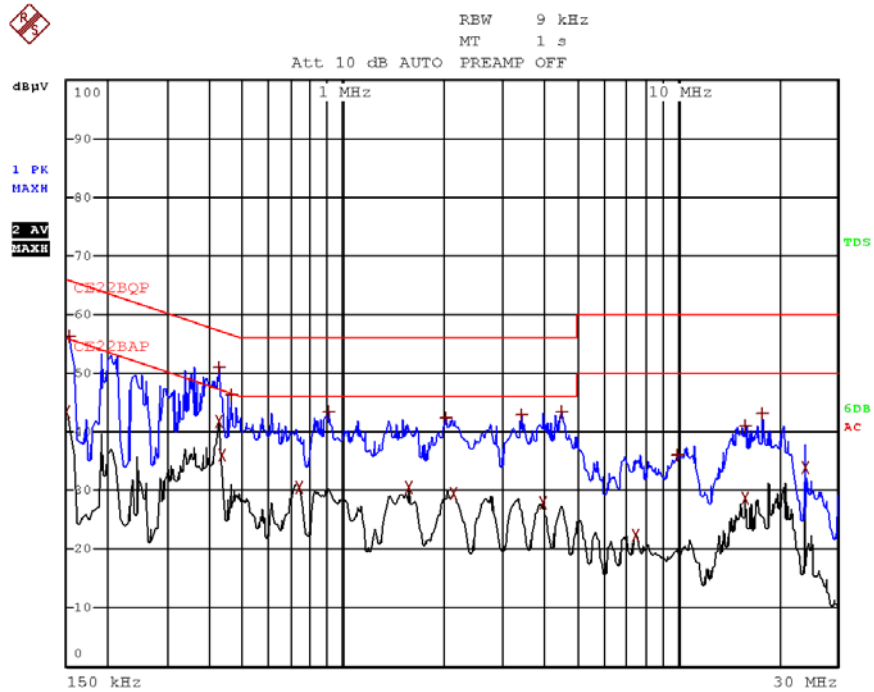

Date: 21.JUN.2018 12:22:38

Figure 10. Detectors: Peak, Quasi-peak, Average



## Conducted Emission

E.U.T Description Relivion  
Type RLV3  
Serial Number: R03182100003

Specification: FCC Part 15, Subpart C  
Lead: Neutral  
Detectors: Peak, Quasi-peak, Average  
Power Operation AC/DC charger

EDIT PEAK LIST (Final Measurement Results)				
Trace1:	CE22BQP			
Trace2:	CE22BAP			
Trace3:	---			
TRACE		FREQUENCY	LEVEL dBµV	DELTA LIMIT dB
2	Average	150 kHz	35.07	-20.92
1	Quasi Peak	198 kHz	47.84	-15.84
1	Quasi Peak	418 kHz	41.35	-16.13
2	Average	422 kHz	34.98	-12.42
1	Quasi Peak	434 kHz	40.59	-16.57
2	Average	434 kHz	29.69	-17.48
2	Average	834 kHz	22.48	-23.51
1	Quasi Peak	878 kHz	30.80	-25.19
1	Quasi Peak	1.41 MHz	31.28	-24.71
2	Average	1.978 MHz	19.95	-26.04
2	Average	2.55 MHz	19.14	-26.85
1	Quasi Peak	2.75 MHz	30.33	-25.66
2	Average	3.706 MHz	17.07	-28.92
1	Quasi Peak	4.418 MHz	28.29	-27.71
2	Average	7.178 MHz	13.68	-36.31
1	Quasi Peak	10.39 MHz	27.02	-32.97
1	Quasi Peak	15.906 MHz	33.19	-26.80
2	Average	17.17 MHz	25.45	-24.54
1	Quasi Peak	20.814 MHz	34.47	-25.52
2	Average	24.046 MHz	30.81	-19.18

Date: 21.JUN.2018 12:18:42

### Figure 11. Detectors: Peak, Quasi-peak, Average

*Note: QP Delta/Av Delta refers to the test results obtained minus specified requirement; thus a positive number indicates failure, and a negative result indicates that the product passes the test.*

# Conducted Emission

E.U.T Description Relivion  
Type RLV3  
Serial Number: R03182100003

Specification: FCC Part 15, Subpart C  
Lead: Neutral  
Detectors: Peak, Quasi-peak, Average  
Power Operation AC/DC adapter

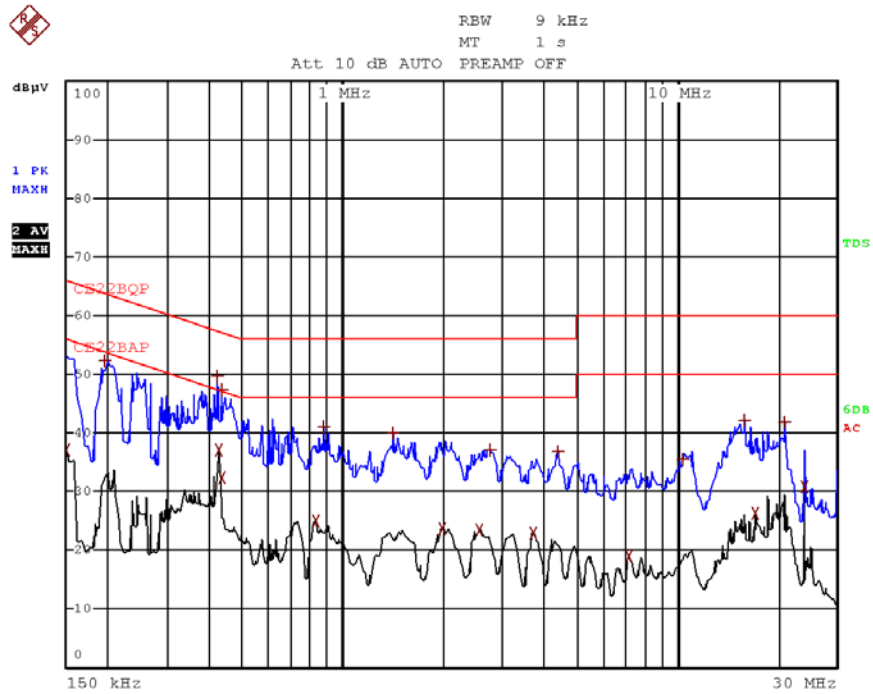

Date: 21.JUN.2018 12:17:26

Figure 12 Detectors: Peak, Quasi-peak, Average



#### 4.5 Test Equipment Used; Conducted Emission

<b>Instrument</b>	<b>Manufacturer</b>	<b>Model</b>	<b>Serial No.</b>	<b>Last Calibration Date</b>	<b>Next Calibration Due</b>
LISN	Fischer	FCC-LISN-25A	127	July 20, 2017	July 20, 2018
Transient Limiter	HP	11947A	3107A03041	June 29, 2017	June 29, 2018
EMI Receiver	Rohde & Schwarz	ESCI7	100724	February 19, 2018	February 19, 2019
Cable CE Chamber 3M + 3M	Testline 18 + RJ214	11556	-	March 31, 2018	March 31, 2019

**Figure 13 Test Equipment Used**

## 5. 6 dB Minimum Bandwidth

### 5.1 Test Specification

FCC Part 15, Subpart C, Section 247(a)(2)

### 5.2 Test Procedure

(Temperature (22°C)/ Humidity (68%RH))

The E.U.T operation mode and test set-up are as described in Section 2 of this report.

The E.U.T was tested in the chamber, and placed on a remote-controlled turntable. The E.U.T was placed on a non-metallic table, 1.5 meters above the ground. The emissions were measured at a distance of 3 meters.

The spectrum bandwidth of the E.U.T. at the point of 6 dB below maximum peak power was measured and recorded. The RBW was set to 100 kHz.

### 5.3 Test Limit

Systems using digital modulation techniques may operate in the 902-928 MHz, 2400-2483.5 MHz, and 5725-5850 MHz bands. The minimum 6 dB bandwidth shall be at least 500 kHz.

### 5.4 Test Results

Protocol Type	Operation Frequency	Reading	Limit
	(MHz)	(kHz)	(kHz)
BLE	2402.0	709.0	>500.0
	2440.0	699.0	>500.0
	2480.0	699.0	>500.0

Figure 14 6 dB Minimum Bandwidth

JUDGEMENT: Passed

For additional information see *Figure 15* to *Figure 17*.

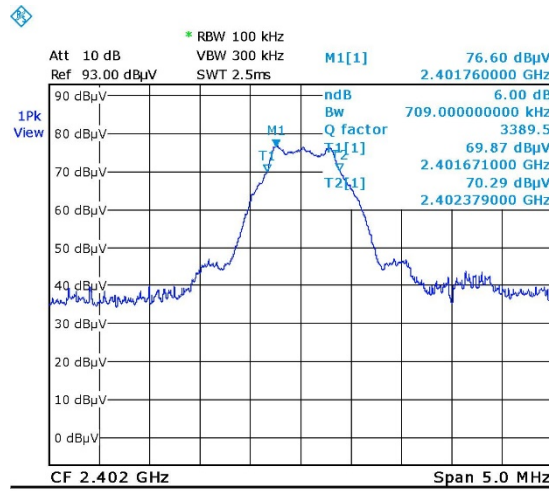

Date: 17.JUN.2018 10:30:02

Figure 15. 2402.0 MHz

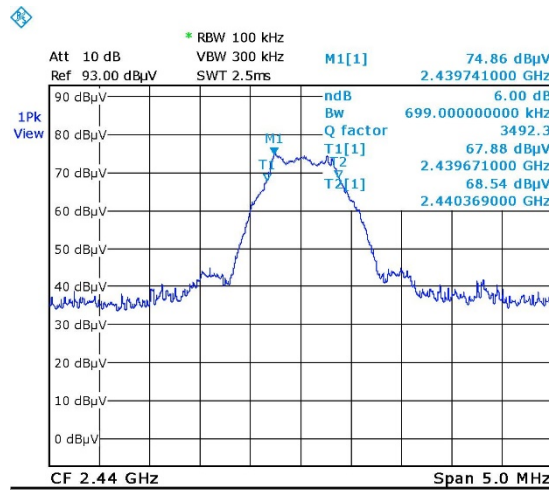

Date: 17.JUN.2018 10:33:26

Figure 16. 2440.0 MHz

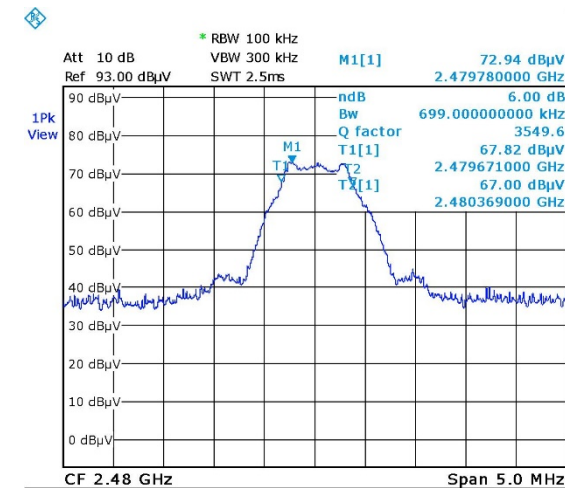

Date: 17.JUN.2018 10:32:45

Figure 17. 2480.0 MHz



**5.5 Test Equipment Used; 6dB Bandwidth**

<b>Instrument</b>	<b>Manufacturer</b>	<b>Model</b>	<b>Serial No.</b>	<b>Last Calibration Date</b>	<b>Next Calibration Due</b>
Spectrum Analyzer	R&S	FSL6	100194	February 19, 2018	February 19, 2019
Horn Antenna	ETS	3115	6142	May 31, 2018	May 31, 2021
Semi Anechoic Civil Chamber	ETS	S81	SL 11643	NCR	NCR
10 m RF cable	Commscope ORS	0623 WBC-400	G020132	October 1, 2017	October 1, 2018

**Figure 18 Test Equipment Used**

## 6. Maximum Transmitted Peak Power Output

### 6.1 Test Specification

FCC, Part 15, Subpart C, Section 247(b)(3)

### 6.2 Test Procedure

(Temperature (22°C)/ Humidity (65%RH))

The E.U.T operation mode and test set-up are as described in Section 2 of this report.

The E.U.T was tested in the chamber, and placed on a remote-controlled turntable. The E.U.T was placed on a non-metallic table, 1.5 meters above the ground. The readings were maximized by the turntable azimuth between 0-360°, and the antenna polarization.

The emissions were measured at a distance of 3 meters.

Radiated output power levels were measured at selected operation frequencies and the results were converted to power level according to the formula as shown below:

$$P = \frac{(E_{V/m} \times d)^2}{(30 \times G)} \quad [\text{W}]$$

E - Field Strength (V/m)

d – Distance from transmitter (m)

G – Antenna gain

P – Peak power (W)

### 6.3 Test Limit

The maximum peak conducted output power of the intentional radiator for systems using digital modulation in the 902-928 MHz, 2400-2483.5 MHz, and 5725-5850 MHz bands: 1 Watt.



## 6.4 Test Results

Operation Frequency (MHz)	Pol. (V/H)	Field Strength (dBuV/m)	EIRP (dBm)	Antenna Gain (dBi)	Conducted Power (dBm)	Conducted Power (mW)	Limit (mW)	Margin (mW)
2402.0	V	87.9	-7.3	0.5	-7.8	0.166	1000.0	-999.834
	H	90.2	-5.0	0.5	-5.5	0.282	1000.0	-999.718
2440.0	V	84.5	-10.7	0.5	-11.2	0.076	1000.0	-999.924
	H	90.6	-4.6	0.5	-5.1	0.309	1000.0	-999.691
2480.0	V	83.1	-12.1	0.5	-12.6	0.055	1000.0	-999.945
	H	89.7	-5.5	0.5	-6.0	0.251	1000.0	-999.749

**Figure 19 Maximum Peak Power Output**

JUDGEMENT: Passed by 999.691 mW

For additional information see *Figure 20* to *Figure 25*.

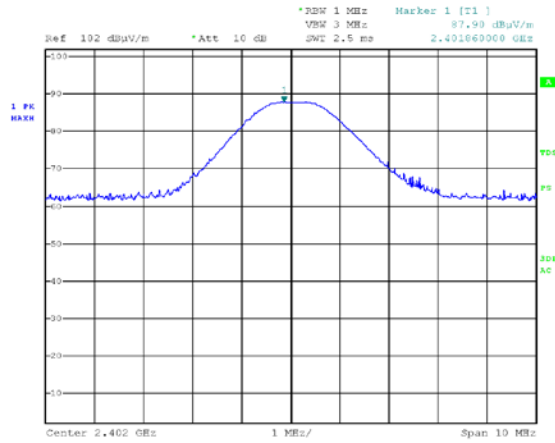

Date: 17.JUN.2018 17:25:45

Figure 20 2402.0 MHz – Vertical

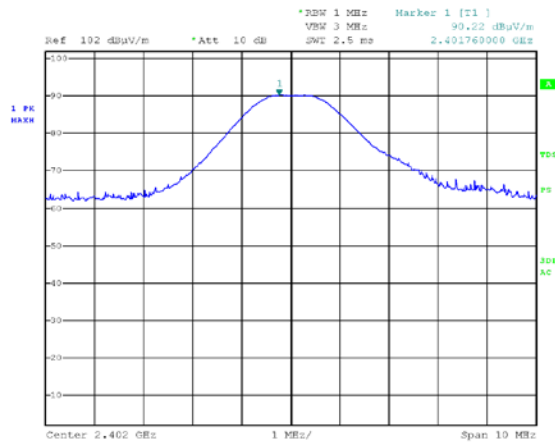

Date: 17.JUN.2018 17:20:55

Figure 21 2402.0 MHz – Horizontal

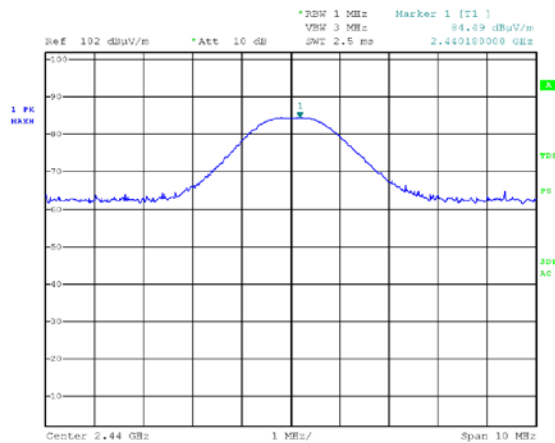

Date: 17.JUN.2018 17:45:11

Figure 22 2440.0 MHz – Vertical

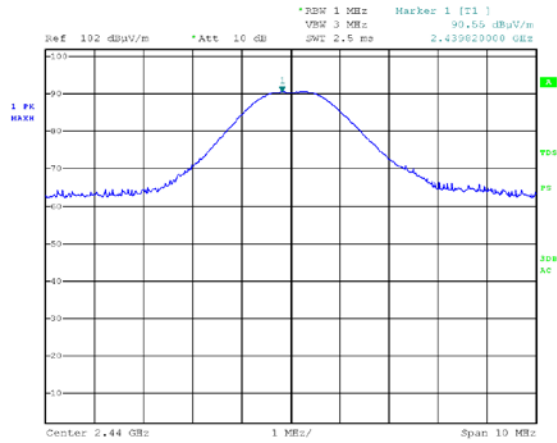

Date: 17.JUN.2018 17:41:01

Figure 23 2440.0 MHz – Horizontal

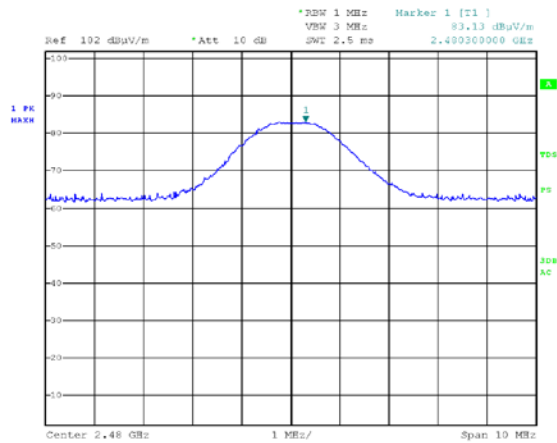

Date: 17.JUN.2018 17:48:21

Figure 24 2480.0 MHz – Vertical

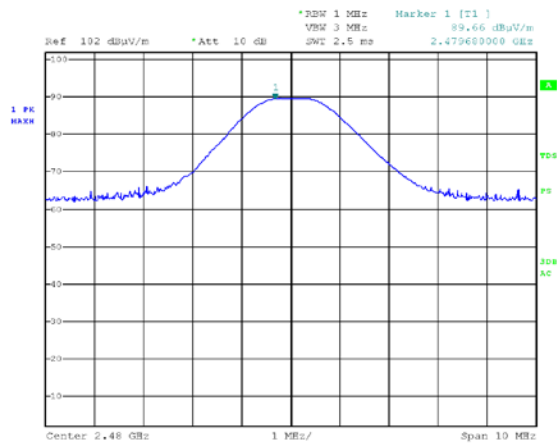

Date: 17.JUN.2018 17:52:17

Figure 25 2480.0 MHz – Horizontal



### 6.5 Test Equipment Used; Maximum Peak Power Output

<b>Instrument</b>	<b>Manufacturer</b>	<b>Model</b>	<b>Serial No.</b>	<b>Last Calibration Date</b>	<b>Next Calibration Due</b>
EMI Receiver	R&S	ESCI7	100724	February 19, 2018	February 19, 2019
Horn Antenna	ETS	3115	6142	May 31, 2018	May 31, 2021
Semi Anechoic Civil Chamber	ETS	S81	SL 11643	NCR	NCR
10 m RF cable	Commscope ORS	0623 WBC-400	G020132	October 1, 2017	October 1, 2018

**Figure 26 Test Equipment Used**

## 7. Band Edge Spectrum

### 7.1 Test Specification

FCC, Part 15, Subpart C, Section 247(d)

### 7.2 Test Procedure

(Temperature (22°C)/ Humidity (65%RH))

The E.U.T operation mode and test set-up are as described in Section 2 of this report.

The E.U.T was tested in the chamber, and placed on a remote-controlled turntable. The E.U.T was placed on a non-metallic table, 1.5 meters above the ground. The readings were maximized by the turntable azimuth between 0-360°, and the antenna polarization.

The emissions were measured at a distance of 3 meters

The RBW was set to 100 kHz.

### 7.3 Test Limit

In any 100 kHz bandwidth outside the frequency band in which the spread spectrum or digitally modulated intentional radiator is operating, the radio frequency power that is produced by the intentional radiator shall be at least 20 dB below that in the 100 kHz bandwidth within the band that contains the highest level of the desired power.

### 7.4 Test Results

Protocol Type	Operation Frequency (MHz)	Band Edge Frequency (MHz)	Spectrum Level (dBuV/m)	Limit (dBuV/m)	Margin (dB)
BLE	2402.0	2400.0	29.1	60.4	-31.3
	2480.0	2483.5	32.7	64.0	-31.3

Figure 27 Band Edge Spectrum

JUDGEMENT: Passed by 31.3 dB

For additional information see *Figure 28* and *Figure 29*.

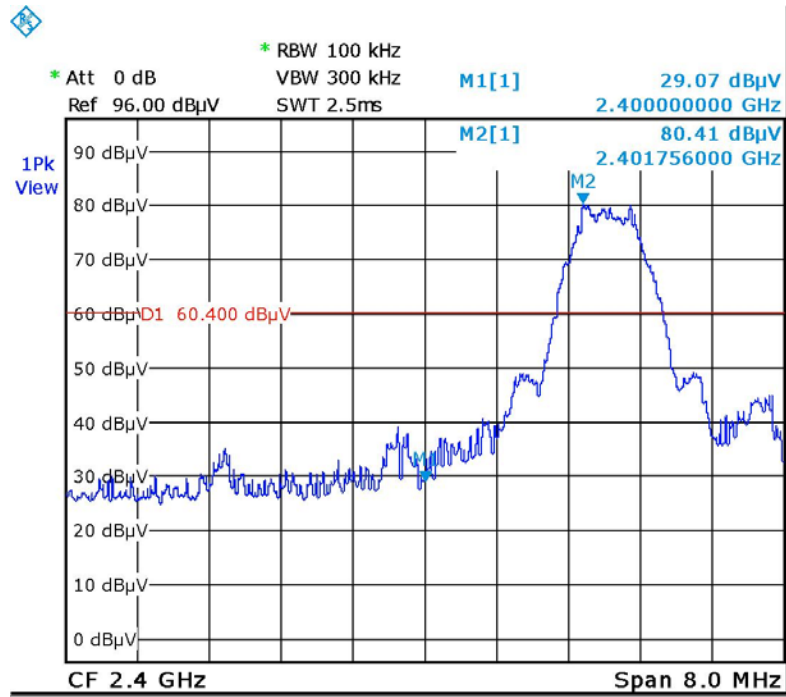

Date: 17.JUN.2018 10:42:03

Figure 28 —Lower Band Edge

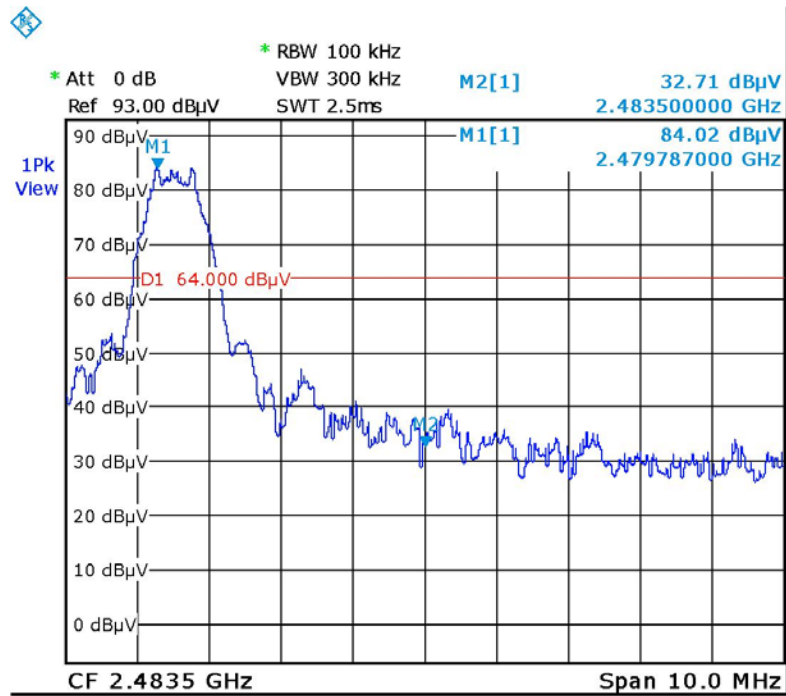

Date: 17.JUN.2018 10:40:05

Figure 29 —Upper Band Edge



**7.5 Test Equipment Used; Band Edge Spectrum**

<b>Instrument</b>	<b>Manufacturer</b>	<b>Model</b>	<b>Serial No.</b>	<b>Last Calibration Date</b>	<b>Next Calibration Due</b>
EMI Receiver	R&S	ESCI7	100724	February 19, 2018	February 19, 2019
Horn Antenna	ETS	3115	6142	May 31, 2018	May 31, 2021
Semi Anechoic Civil Chamber	ETS	S81	SL 11643	NCR	NCR
10 m RF cable	Commscope ORS	0623 WBC-400	G020132	October 1, 2017	October 1, 2018

**Figure 30 Test Equipment Used**

## 8. Emissions in Non-Restricted Frequency Bands

### 8.1 Test Specification

FCC, Part 15, Subpart C, Section 247(d)

### 8.2 Test Procedure

(Temperature (22°C)/ Humidity (68%RH))

The E.U.T. operation mode and test set-up are as described in Section 2 of this report.

#### **For measurements between 0.009MHz-30MHz:**

The E.U.T was tested inside the shielded room and placed on a non-metallic table, 0.8 meters above the ground. The emissions were measured at a distance of 3 meters. The readings were maximized by the turntable azimuth between 0-360°, and the antenna polarization.

The frequency range 0.009MHz-30MHz was scanned.

#### **For measurements between 30.0MHz-1.0GHz:**

A preliminary measurement to characterize the E.U.T was performed inside the shielded room at a distance of 3 meters, using peak detection mode and broadband antennas. The preliminary measurements produced a list of the highest emissions. The E.U.T was then transferred to the open site, and placed on a remote-controlled turntable. The E.U.T was placed on a non-metallic table, 0.8 meters above the ground. The emissions were measured at a distance of 3 meters. The readings were maximized by adjusting the antenna height between 1-4 meters, the turntable azimuth between 0-360°, and the antenna polarization. The frequency range 30.0MHz -1.0GHz was scanned and the list of the highest emissions was verified and updated accordingly.

#### **For measurements between 1.0GHz-25.0GHz:**

The E.U.T was tested inside the shielded room and placed on a non-metallic table, 1.5 meters above the ground. The emissions were measured at a distance of 3 meters. The readings were maximized by the turntable azimuth between 0-360°, and the antenna polarization.

The frequency range 1.0GHz -25.0GHz was scanned.

RBW was set to 100kHz, detector set to max peak and trace to “max hold”.

### 8.3 Test Limit

In any 100 kHz bandwidth outside the frequency band in which the spread spectrum or digitally modulated intentional radiator is operating, the radio frequency power that is produced by the intentional radiator shall be at least 20 dB below that in the 100 kHz bandwidth within the band that contains the highest level of the desired power.

### 8.4 Test Results

JUDGEMENT: Passed

All detected emissions were greater than 20dBc below the fundamental level.

The EUT met the requirements of the F.C.C. Part 15, Subpart C, Section 247(d) specification.





### 8.5 Test Instrumentation Used, Emission in Non Restricted Frequency Bands

Instrument	Manufacturer	Model	Serial No.	Last Calibration Date	Next Calibration Due
EMI Receiver	R&S	ESCI7	100724	February 19, 2018	February 19, 2019
Spectrum Analyzer	HP	8593EM	3536A00120 ADI	February 20, 2018	February 20, 2019
EMI Receiver	HP	8542E	3906A00276	February 19, 2018	February 19, 2019
RF Filter Section	HP	85420E	3705A00248	February 19, 2018	February 19, 2019
Spectrum Analyzer	HP	8564E	3442A00275	February 28, 2018	February 28, 2019
Biconical Antenna	EMCO	3110B	9912-3337	May 15, 2017	May 15, 2019
Log Periodic Antenna	EMCO	3146	9505-4081	May 31, 2018	May 31, 2019
Horn Antenna	ETS	3115	29845	May 31, 2018	May 31, 2021
Horn Antenna	ARA	SWH-28	1007	December 13, 2017	December 13, 2020
Active Loop Antenna	EMCO	6502	9506-2950	October 19, 2017	October 19, 2018
MicroWave System Amplifier	HP	83006A	3104A00589	October 1, 2017	October 1, 2018
Low noise amplifier 1GHz-18GHz	Miteq	AFSX4-02001800-50-8P	-	October 1, 2017	October 1, 2018
10 m RF cable	Commscope ORS	0623 WBC-400	G020132	October 1, 2017	October 1, 2018
Oats RF cable	EIM	RG214-11N(X2)	-	August 13, 2017	August 13, 2018
Semi Anechoic Civil Chamber	ETS	S81	SL 11643	NCR	NCR
Antenna Mast	ETS	2070-2	9608-1497	NCR	NCR
Turntable	ETS	2087	-	NCR	NCR
Mast & Table Controller	ETS/EMCO	2090	9608-1456	NCR	NCR

Figure 31 Test Equipment Used



## 8.6 **Field Strength Calculation**

The field strength is calculated directly by the EMI Receiver software, and a "Correction Factors", using the following equation:

$$FS = RA + AF + CF$$

- FS: Field Strength [dB $\mu$ v/m]
- RA: Receiver Amplitude [dB $\mu$ v]
- AF: Receiving Antenna Correction Factor [dB/m]
- CF: Cable Attenuation Factor [dB]

Example:  $FS = 30.7 \text{ dB}\mu\text{V (RA)} + 14.0 \text{ dB (AF)} + 0.9 \text{ dB (CF)} = 45.6 \text{ dB}\mu\text{V}$

No external pre-amplifiers are used.

## 9. Emissions in Restricted Frequency Bands

### 9.1 Test Specification

FCC Part 15, Subpart C, Sections 15.209, 15.205, 15.247(d)

### 9.2 Test Procedure

(Temperature (22°C)/ Humidity (68%RH))

The E.U.T. operation mode and test set-up are as described in Section 2 of this report.

#### **For measurements between 0.009-30MHz:**

The E.U.T was tested inside the shielded room and placed on a non-metallic table, 0.8 meters above the ground. The emissions were measured at a distance of 3 meters. The readings were maximized by the turntable azimuth between 0-360°, and the antenna polarization.

The frequency range 0.009MHz-30MHz was scanned.

#### **For measurements between 30-1000MHz:**

A preliminary measurement to characterize the E.U.T was performed inside the shielded room at a distance of 3 meters, using peak detection mode and broadband antennas. The preliminary measurements produced a list of the highest emissions. The E.U.T was then transferred to the open site, and placed on a remote-controlled turntable. The E.U.T was placed on a non-metallic table, 0.8 meters above the ground. The emissions were measured at a distance of 3 meters. The readings were maximized by adjusting the antenna height between 1-4 meters, the turntable azimuth between 0-360°, and the antenna polarization. The frequency range 30MHz -1000MHz was scanned and the list of the highest emissions was verified and updated accordingly.

#### **For measurements between 1GHz-25GHz:**

The E.U.T was tested inside the shielded room and placed on a non-metallic table, 1.5 meters above the ground. The emissions were measured at a distance of 3 meters. The readings were maximized by the turntable azimuth between 0-360°, and the antenna polarization.

The frequency range 1GHz -25GHz was scanned.

The levels of the emissions within the frequency ranges of the restricted bands (Section 15.205 of FCC Part 15) were compared to the limits of the table in Section 15.209 (a), General Requirements.

### 9.3 Test Limit

Radiated emissions which fall in the restricted bands, as defined in §15.205(a), must also comply with the radiated emission limits specified in §15.209(a) (see §15.205(c)).

Frequency (MHz)	Field strength (microvolts/meter)	Measurement distance (meters)	Field strength* (dBµV/m)	Field strength* (dBµV/m)@3m
0.009-0.490	2400/F(kHz)	300	48.5-13.8	128.5-73.8
0.490-1.705	24000/F(kHz)	30	33.8-23.0	73.8-63.0
1.705-30.0	30	30	29.5	69.5
30-88	100	3	40.0	40.0
88-216	150	3	43.5	43.5
216-960	200	3	46.0	46.0
Above 960	500	3	54.0	54.0

\*The emission limits shown in the above table are based on measurements employing a CISPR quasi-peak detector except for the frequency bands 9-90 kHz, 110-490 kHz and above 1000 MHz. Radiated emission limits in these three bands are based on measurements employing an average detector. For average radiated emission measurements above 1000 MHz, there is also a limit corresponding to 20 dB above the indicated values in the table is specified when measuring with peak detector function.

Figure 32 Table of Limits

### 9.4 Test Results

JUDGEMENT: Passed by 2.3 dB

For the operation frequency of 2402 MHz, the margin between the emission level and the specification limit is in the worst case 9.8 dB at the frequency of 2390.0 MHz, vertical and horizontal polarization.

For the operation frequency of 2440 MHz, the margin between the emission level and the specification limit is in the worst case 26.6 dB at the frequency of 7320.0 MHz, horizontal polarization.

For the operation frequency of 2480 MHz, the margin between the emission level and the specification limit is in the worst case 2.3 dB at the frequency of 2483.5 MHz, horizontal polarization.

The EUT met the requirements of the F.C.C. Part 15, Subpart C Sections 15.209, 15.205, 15.247(d) specifications.

The details of the highest emissions are given in *Figure 33*.



## Radiated Emission

E.U.T Description Relivion  
Type RLV3  
Serial Number: R03182100003

Specification: FCC, Part 15, Subpart C, Sections 15.209, 15.205, 15.247(d)

Antenna Polarization: Horizontal/Vertical Frequency Range: 9KHz to 25.0 GHz  
Protocol type: BLE Detector: Peak ,Average

Operation Frequency	Freq.	Pol	Peak Reading	Peak Limit	Peak Margin	Average Reading	Average Limit	Average Margin
(MHz)	(MHz)	(H/V)	(dBµV/m)	(dBµV/m)	(dB)	(dBµV/m)	(dBµV/m)	(dB)
2402.0	2390.0	V	54.9	74.0	-19.1	44.2	54.0	-9.8
	2390.0	H	54.7	74.0	-19.3	44.2	54.0	-9.8
	4804.0	V	49.7	74.0	-24.3	-	54.0	-
	4804.0	H	47.3	74.0	-26.7	-	54.0	-
2440.0	4880.0	V	45.0	74.0	-29.0	-	54.0	-
	4880.0	H	44.7	74.0	-29.3	-	54.0	-
	7320.0	V	47.0	74.0	-27.0	-	54.0	-
	7320.0	H	47.4	74.0	-26.6	-	54.0	-
2480.0	4960.0	V	44.5	74.0	-29.5	-	54.0	-
	4960.0	H	45.1	74.0	-28.9	-	54.0	-
	2483.5	V	55.4	74.0	-18.6	46.9	54.0	-7.1
	2483.5	H	59.5	74.0	-14.5	51.7	54.0	-2.3

**Figure 33. Radiated Emission Results**

Margin refers to the test results obtained minus specified requirement; thus a positive number indicates failure, and a negative result indicates that the product passes the test.

“Peak Amp” includes correction factor.

\* “Correction Factor” = Antenna Factor + Cable Loss- Low Noise Amplifier Gain



### 9.5 Test Instrumentation Used; Emissions in Restricted Frequency Bands

Instrument	Manufacturer	Model	Serial No.	Last Calibration Date	Next Calibration Due
EMI Receiver	R&S	ESCI7	100724	February 19, 2018	February 19, 2019
Spectrum Analyzer	HP	8593EM	3536A00120 ADI	February 20, 2018	February 20, 2019
EMI Receiver	HP	8542E	3906A00276	February 19, 2018	February 19, 2019
RF Filter Section	HP	85420E	3705A00248	February 19, 2018	February 19, 2019
Spectrum Analyzer	HP	8564E	3442A00275	February 28, 2018	February 28, 2019
Biconical Antenna	EMCO	3110B	9912-3337	May 15, 2017	May 15, 2019
Log Periodic Antenna	EMCO	3146	9505-4081	May 31, 2018	May 31, 2019
Horn Antenna	ETS	3115	29845	May 31, 2018	May 31, 2021
Horn Antenna	ARA	SWH-28	1007	December 13, 2017	December 13, 2020
Active Loop Antenna	EMCO	6502	9506-2950	October 19, 2017	October 19, 2018
MicroWave System Amplifier	HP	83006A	3104A00589	October 1, 2017	October 1, 2018
Low noise amplifier 1GHz-18GHz	Miteq	AFSX4-02001800-50-8P	-	October 1, 2017	October 1, 2018
10 m RF cable	Commscope ORS	0623 WBC-400	G020132	October 1, 2017	October 1, 2018
Oats RF cable	EIM	RG214-11N(X2)	-	August 13, 2017	August 13, 2018
Semi Anechoic Civil Chamber	ETS	S81	SL 11643	NCR	NCR
Antenna Mast	ETS	2070-2	9608-1497	NCR	NCR
Turntable	ETS	2087	-	NCR	NCR
Mast & Table Controller	ETS/EMCO	2090	9608-1456	NCR	NCR

Figure 34 Test Equipment Used

## 10. Transmitted Power Density

### 10.1 Test Specification

FCC, Part 15, Subpart C, Section 247(e)

### 10.2 Test Procedure

(Temperature (22°C)/ Humidity (68%RH))

The E.U.T operation mode and test set-up are as described in Section 2 of this report.

The E.U.T was tested in the chamber, and placed on a remote-controlled turntable. The E.U.T was placed on a non-metallic table, 1.5 meters above the ground.

The readings were maximized by the turntable azimuth between 0-360°, and the antenna polarization.

The emissions were measured at a distance of 3 meters.

The spectrum analyzer was set to 3 kHz RBW and VBW to 10 kHz.

Radiated output power levels were measured at selected operation frequencies and the results were converted to power level according to the formula as shown below:

$$P = \frac{(E_{v/m} \times d)^2}{(30 \times G)} \quad [\text{W}]$$

E - Field Strength (V/m)

d – Distance from transmitter (m)

G – Antenna gain

P – Peak power (W)

### 10.3 Test Limit

For digitally modulated systems, the power spectral density conducted from the intentional radiator to the antenna shall not be greater than 8 dBm in any 3 kHz band during any time interval of continuous transmission.

### 10.4 Test Results

Protocol Type	Operation Frequency (MHz)	Reading Spectrum Analyzer (dBμV/m)	Reading Spectrum Analyzer (dBm)	Limit (dBm)	Margin (dB)
BLE	2402.0	74.5	-20.7	8.0	-28.7
	2440.0	74.7	-20.5	8.0	-28.5
	2480.0	74.0	-21.2	8.0	-29.2

Figure 35 Test Results

JUDGEMENT: Passed by 28.5dB

For additional information see *Figure 36 to Figure 38*.

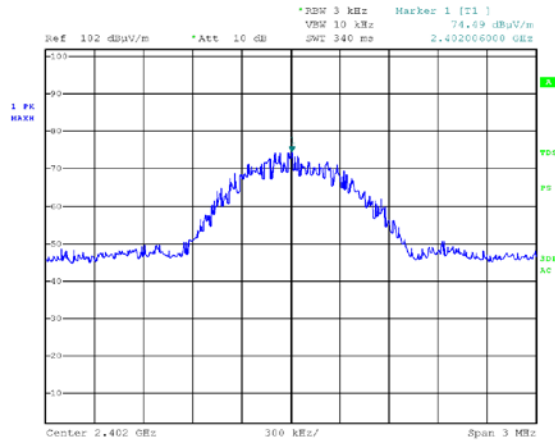

Date: 17.JUN.2018 17:22:29

Figure 36 — 2402.0 MHz

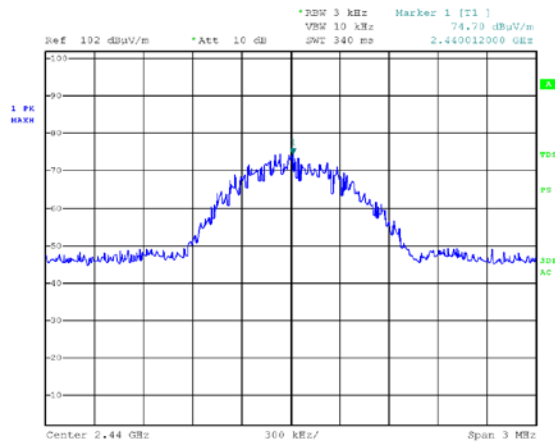

Date: 17.JUN.2018 17:42:11

Figure 37 — 2440.0 MHz

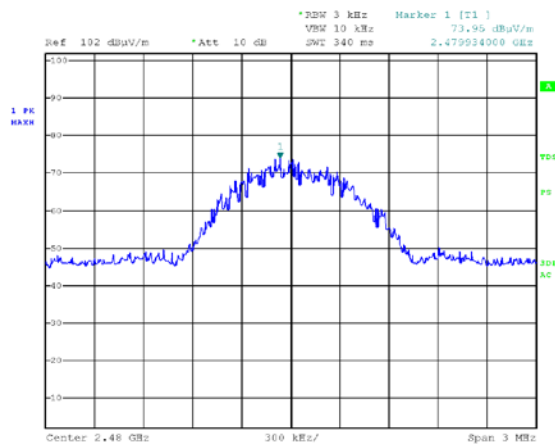

Date: 17.JUN.2018 17:54:03

Figure 38 — 2480.0 MHz





**10.5 Test Equipment Used; Transmitted Power Density**

<b>Instrument</b>	<b>Manufacturer</b>	<b>Model</b>	<b>Serial No.</b>	<b>Last Calibration Date</b>	<b>Next Calibration Due</b>
EMI Receiver	R&S	ESCI7	100724	February 19, 2018	February 19, 2019
Horn Antenna	ETS	3115	29845	May 31, 2018	May 31, 2021
Semi Anechoic Civil Chamber	ETS	S81	SL 11643	NCR	NCR
10 m RF cable	Commscope ORS	0623 WBC-400	G020132	October 1, 2017	October 1, 2018

**Figure 39 Test Equipment Used**



## 11. Antenna Gain/Information

The antenna gain is 0.5 dBi, integral.

### Mini 2.45 GHz Antenna

Detail Specification: 7/18/2014

P/N 2450AT18A100

Page 1 of 4

General Specifications	
Part Number	2450AT18A100
Frequency Range	2400 - 2500 Mhz
Peak Gain	0.5 dBi typ. (XZ-V)
Average Gain	-0.5 dBi typ. (XZ-V)
Return Loss	9.5 dB min.
Input Power	2W max. (CW)
Impedance	50 $\Omega$
Operating Temperature	-40 to +125°C
Reel Quantity	3,000



## 12. R.F Exposure/Safety

Typical use of the E.U.T. is as a migraine treatment device.

The typical placement of the E.U.T. is on the forehead. The typical distance between the E.U.T. and the user is 0.25 cm.

SAR Testing Exclusion Based on Section 4.3.1 and Appendix A of KDB 447498 D01 V06 Requirements

### **For FCC**

Section 4.3.1 and Appendix A of KDB447498 D01 V06 was used as the guidance as follows:

Conducted power output (standard) = -5.1dBm

EIRP = -5.1 dBm +(0.5 dBi) = -4.6dBm = 0.347 mW.

$[(\text{max. power of channel, including tune-up tolerance, mW})/(\text{min. test separation distance, mm})] * [\sqrt{f(\text{GHz})}]$

= $0.347/2.5 * 1.55=0.22$  this value is less than 3.0 for 1-g SAR and  $\leq 7.5$  for 10-g extremity SAR.

The SAR measurement is not necessary.



## 13. APPENDIX A - CORRECTION FACTORS

### 13.1 Correction factors for RF OATS Cable 35m ITL #1911

Frequency (MHz)	Ref&cable loss (dBm)	Ref loss (dBm)	Cable loss (dB)
1.00	0.7	0.2	0.5
10.00	1.3	0.3	1
20.00	1.7	0.3	1.34
30.00	2.0	0.5	1.5
50.00	2.3	0.5	1.83
100.00	3.0	0.3	2.67
150.00	3.7	0.5	3.17
200.00	4.3	0.5	3.83
250.00	4.5	0.3	4.17
300.00	5.0	0.5	4.5
350.00	5.7	0.5	5.17
400.00	6.0	0.5	5.5
450.00	6.5	0.7	5.83
500.00	6.8	0.5	6.33
550.00	7.2	0.5	6.67
600.00	7.5	0.7	6.83
650.00	7.7	0.5	7.17
700.00	8.3	0.7	7.66
750.00	8.5	0.7	7.83
800.00	8.8	0.7	8.16
850.00	9.0	0.5	8.5
900.00	9.5	0.7	8.83
950.00	9.7	0.8	8.84
1000.00	9.7	0.7	9



### 13.2 Correction factor for RF CABLE for Semi Anechoic Chamber

*ITL # 1841*

FREQ (MHz)	LOSS (dB)
1000.0	1.5
2000.0	2.1
3000.0	2.7
4000.0	3.1
5000.0	3.5
6000.0	4.1
7000.0	4.6
8000.0	4.9
9000.0	5.7
10000.0	5.7
11000.0	6.1
12000.0	6.1
13000.0	6.2
14000.0	6.7
15000.0	7.4
16000.0	7.5
17000.0	7.9
18000.0	8.1
19000.0	8.8
20000.0	9.1

**NOTES:**

- 1. The cable is manufactured by Commscope*
- 2. The cable type is 0623 WBC-400, serial # G020132 and 10m long*



**13.3 Correction factors for Active Loop Antenna**

**Model 6502 S/N 9506-2950**

**ITL # 1075:**

f(MHz)	MAF(dBs/m)	AF(dB/m)
0.01	-33.1	18.4
0.02	-37.2	14.3
0.03	-38.2	13.3
0.05	-39.8	11.7
0.1	-40.1	11.4
0.2	-40.3	11.2
0.3	-40.3	11.2
0.5	-40.3	11.2
0.7	-40.3	11.2
1	-40.1	11.4
2	-40	11.5
3	-40	11.5
4	-40.1	11.4
5	-40.2	11.3
6	-40.4	11.1
7	-40.4	11.1
8	-40.4	11.1
9	-40.5	11
10	-40.5	11
20	-41.5	10
30	-43.5	8



**13.4 Correction factors for biconical antenna – ITL # 1356**

**Model: EMCO 3110B**

**Serial No.:9912-3337**

<b>Frequency</b> <b>[MHz]</b>	<b>ITL 1356 AF</b> <b>[dB/m]</b>
<b>30</b>	13.00
<b>35</b>	10.89
<b>40</b>	10.59
<b>45</b>	10.63
<b>50</b>	10.12
<b>60</b>	9.26
<b>70</b>	7.74
<b>80</b>	6.63
<b>90</b>	8.23
<b>100</b>	11.12
<b>120</b>	13.16
<b>140</b>	13.07
<b>160</b>	14.80
<b>180</b>	16.95
<b>200</b>	17.17



**13.5 Correction factors for log periodic antenna – ITL # 1349**

**Model: EMCO 3146**

**Serial No.:9505-4081**

<b>Frequency</b>	<b>ITL 1349 AF</b>
<b>[MHz]</b>	<b>[dB/m]</b>
200	11.58
250	12.04
300	14.76
400	15.55
500	17.85
600	18.66
700	20.87
800	21.15
900	22.32
1000	24.22





**13.6 Correction factors for Double –Ridged Waveguide  
Horn ANTENNA**

**Model: 3115**  
**Serial number:29845**  
**3 meter range; ITL # 1352**

<b>FREQUENCY</b>	<b>AFE</b>	<b>FREQUENCY</b>	<b>AFE</b>
<b>(GHz)</b>	<b>(dB/m)</b>	<b>(GHz)</b>	<b>(dB/m)</b>
0.75	25	9.5	38
1.0	23.5	10.0	38.5
1.5	26.0	10.5	38.5
2.0	29.0	11.0	38.5
2.5	27.5	11.5	38.5
3.0	30.0	12.0	38.0
3.5	31.5	12.5	38.5
4.0	32.5	13.0	40.0
4.5	32.5	13.5	41.0
5.0	33.0	14.0	40.0
5.5	35.0	14.5	39.0
6.0	36.5	15.0	38.0
6.5	36.5	15.5	37.5
7.0	37.5	16.0	37.5
7.5	37.5	16.5	39.0
8.0	37.5	17.0	40.0
8.5	38.0	17.5	42.0
9.0	37.5	18.0	42.5



**13.7 Correction factors for**

**Horn Antenna  
Model: SWH-28  
at 3 meter range.  
ITL #:1353**

**CALIBRATION DATA**

**3 m distance**

Frequency MHz	Measured antenna factor, dB/m <sup>1)</sup>
18000	32.4
18500	32.0
19000	32.3
19500	32.4
20000	32.3
20500	32.6
21000	32.8
21500	32.7
22000	33.1
22500	33.0
23000	33.1
23500	33.8
24000	33.5
24500	33.5
25000	33.8
25500	33.9
26000	34.2
26500	34.7

<sup>1)</sup> The antenna factor shall be added to receiver reading in dB $\mu$ V to obtain field strength in dB $\mu$ V/m.