



Shenzhen Huaxia Testing Technology Co., Ltd

1F., Block A of Tongsheng Technology Building, Huahui Road, Dalang Street, Longhua District, Shenzhen, China

Telephone: +86-755-26648640

Fax: +86-755-26648637

Website: www.cqa-cert.com

Report Template Version: V03

Report Template Revision Date: Mar.1st, 2017

Test Report

Report No. : CQASZ20200200089E-02

Applicant: MOKO TECHNOLOGY LIMITED

Address of Applicant: 2F, Building1,No.37 Xiaxintang Xintang village, Fucheng Street, Longhua District , Shenzhen,Guangdong Province, China

Manufacturer: MOKO TECHNOLOGY LIMITED

Address of Manufacturer: 2F, Building1,No.37 Xiaxintang Xintang village, Fucheng Street, Longhua District , Shenzhen,Guangdong Province, China

Factory: MOKO TECHNOLOGY LIMITED

Address of Factory: 2F, Building1,No.37 Xiaxintang Xintang village, Fucheng Street, Longhua District , Shenzhen,Guangdong Province, China

Equipment Under Test (EUT):

Product: Bluetooth Gateway Plug Mini

Model No.: MK110

Brand Name: N/A

FCC ID: 2AO94-MK110

Standards: 47 CFR Part 15, Subpart C

Date of Test: 2020-02-17 to 2020-02-28

Date of Issue: 2020-03-02

Test Result : PASS*

Tested By:

Tom chen.

(Tom chen)

Reviewed By:

Aaron Ma

(Aaron Ma)

Approved By:

Jack Ai

(Jack Ai)



* In the configuration tested, the EUT complied with the standards specified above.

The test report is effective only with both signature and specialized stamp, The result(s) shown in this report refer only to the sample(s) tested. Without written approval of CQA, this report can't be reproduced except in full.

1 Version

Revision History Of Report

Report No.	Version	Description	Issue Date
CQASZ20200200089E-02	Rev.01	Initial report	2020-03-02

2 Test Summary

Test Item	Test Requirement	Test method	Result
Antenna Requirement	47 CFR Part 15, Subpart C Section 15.203/15.247 (c)	ANSI C63.10 2013	PASS
AC Power Line Conducted Emission	47 CFR Part 15, Subpart C Section 15.207	ANSI C63.10 2013	PASS
Conducted Peak & Average Output Power	47 CFR Part 15, Subpart C Section 15.247 (b)(3) KDB 558074	ANSI C63.10 2013	PASS
6dB Occupied Bandwidth	47 CFR Part 15, Subpart C Section 15.247 (a)(2) KDB 558074	ANSI C63.10 2013	PASS
Power Spectral Density	47 CFR Part 15, Subpart C Section 15.247 (e) KDB 558074	ANSI C63.10 2013	PASS
Radiated Spurious Emissions	47 CFR Part 15, Subpart C Section 15.205/15.209 KDB 558074	ANSI C63.10 2013	PASS
Restricted bands around fundamental frequency (Radiated Emission)	47 CFR Part 15, Subpart C Section 15.205/15.209 KDB 558074	ANSI C63.10 2013	PASS

3 Contents

	Page
1 VERSION	2
2 TEST SUMMARY	3
3 CONTENTS	4
4 GENERAL INFORMATION.....	5
4.1 CLIENT INFORMATION	5
4.2 GENERAL DESCRIPTION OF EUT	5
4.3 DESCRIPTION OF SUPPORT UNITS	8
4.4 TEST LOCATION	8
4.5 TEST FACILITY	8
4.6 STATEMENT OF THE MEASUREMENT UNCERTAINTY	9
4.7 DEVIATION FROM STANDARDS	10
4.8 ABNORMALITIES FROM STANDARD CONDITIONS	10
4.9 OTHER INFORMATION REQUESTED BY THE CUSTOMER	10
4.10 EQUIPMENT LIST	11
5 TEST RESULTS AND MEASUREMENT DATA.....	12
5.1 ANTENNA REQUIREMENT	12
5.2 CONDUCTED EMISSIONS	14
5.3 CONDUCTED PEAK OUTPUT POWER	18
5.4 6dB OCCUPY BANDWIDTH	20
5.5 POWER SPECTRAL DENSITY	23
5.6 RADIATED SPURIOUS EMISSIONS.....	26
5.6.1 <i>Radiated emission below 1GHz</i>	29
5.6.2 <i>Transmitter emission above 1GHz</i>	31
5.7 RESTRICTED BANDS AROUND FUNDAMENTAL FREQUENCY	33
6 PHOTOGRAPHS - EUT TEST SETUP	39
6.1 RADIATED SPURIOUS EMISSION.....	39
6.2 CONDUCTED EMISSION.....	40
7 PHOTOGRAPHS - EUT CONSTRUCTIONAL DETAILS	41

4 General Information

4.1 Client Information

Applicant:	MOKO TECHNOLOGY LIMITED
Address of Applicant:	2F, Building1,No.37 Xiaxintang Xintang village, Fucheng Street, Longhua District , Shenzhen,Guangdong Province, China
Manufacturer:	MOKO TECHNOLOGY LIMITED
Address of Manufacturer:	2F, Building1,No.37 Xiaxintang Xintang village, Fucheng Street, Longhua District , Shenzhen,Guangdong Province, China

4.2 General Description of EUT

Product Name:	Bluetooth Gateway Plug Mini																																																																													
Model No.:	MK110																																																																													
Trade Mark:	N/A																																																																													
Type of Modulation:	IEEE 802.11b mode: DSSS(CCK,QPSK, BPSK) IEEE 802.11g mode: OFDM (BPSK/QPSK/16QAM/64QAM) IEEE 802.11n HT20 MHz mode: OFDM (BPSK/QPSK/16QAM/64QAM) IEEE 802.11n HT40 MHz mode: OFDM (BPSK/QPSK/16QAM/64QAM) BLE(GFSK)																																																																													
Channel Spacing:	IEEE 802.11b/g/n(HT20):20MHz IEEE 802.11n(HT40):40MHz BLE:2MHz																																																																													
Operation Frequency:	<table border="1" style="width:100%; border-collapse: collapse;"> <thead> <tr> <th colspan="6" style="text-align:center;">IEEE 802.11b;IEEE 802.11g;IEEE 802.11n HT20</th> </tr> <tr> <th>Channel</th> <th>Frequency (MHz)</th> <th>Channel</th> <th>Frequency (MHz)</th> <th>Channel</th> <th>Frequency (MHz)</th> </tr> </thead> <tbody> <tr> <td>1</td> <td>2412</td> <td>6</td> <td>2437</td> <td>11</td> <td>2462</td> </tr> <tr> <td>2</td> <td>2417</td> <td>7</td> <td>2442</td> <td></td> <td></td> </tr> <tr> <td>3</td> <td>2422</td> <td>8</td> <td>2447</td> <td></td> <td></td> </tr> <tr> <td>4</td> <td>2427</td> <td>9</td> <td>2452</td> <td></td> <td></td> </tr> <tr> <td>5</td> <td>2432</td> <td>10</td> <td>2457</td> <td></td> <td></td> </tr> <tr> <th colspan="6" style="text-align:center;">IEEE 802.11n HT40</th> </tr> <tr> <th>Channel</th> <th>Frequency (MHz)</th> <th>Channel</th> <th>Frequency (MHz)</th> <th>Channel</th> <th>Frequency (MHz)</th> </tr> <tr> <td>1</td> <td>2422</td> <td>4</td> <td>2437</td> <td>7</td> <td>2452</td> </tr> <tr> <td>2</td> <td>2427</td> <td>5</td> <td>2442</td> <td></td> <td></td> </tr> <tr> <td>3</td> <td>2432</td> <td>6</td> <td>2447</td> <td></td> <td></td> </tr> </tbody> </table> <p style="text-align:center;">BLE</p>						IEEE 802.11b;IEEE 802.11g;IEEE 802.11n HT20						Channel	Frequency (MHz)	Channel	Frequency (MHz)	Channel	Frequency (MHz)	1	2412	6	2437	11	2462	2	2417	7	2442			3	2422	8	2447			4	2427	9	2452			5	2432	10	2457			IEEE 802.11n HT40						Channel	Frequency (MHz)	Channel	Frequency (MHz)	Channel	Frequency (MHz)	1	2422	4	2437	7	2452	2	2427	5	2442			3	2432	6	2447		
IEEE 802.11b;IEEE 802.11g;IEEE 802.11n HT20																																																																														
Channel	Frequency (MHz)	Channel	Frequency (MHz)	Channel	Frequency (MHz)																																																																									
1	2412	6	2437	11	2462																																																																									
2	2417	7	2442																																																																											
3	2422	8	2447																																																																											
4	2427	9	2452																																																																											
5	2432	10	2457																																																																											
IEEE 802.11n HT40																																																																														
Channel	Frequency (MHz)	Channel	Frequency (MHz)	Channel	Frequency (MHz)																																																																									
1	2422	4	2437	7	2452																																																																									
2	2427	5	2442																																																																											
3	2432	6	2447																																																																											

Channel No.	Frequency (MHz)	Channel No.	Frequency (MHz)
1	2402	2	2404
3	2406	4	2408
5	2410	6	2412
7	2414	8	2416
9	2418	10	2420
11	2422	12	2424
13	2426	14	2428
15	2430	16	2432
17	2434	18	2436
19	2438	20	2440
21	2442	22	2444
23	2446	24	2448
25	2450	26	2452
27	2454	28	2456
29	2458	30	2460
31	2462	32	2464
33	2466	34	2468
35	2470	36	2472
37	2474	38	2476
39	2478	40	2480

Antenna Type:	PCB antenna
Antenna:	0 dBi gain
Power Supply:	AC 120V/60Hz

Test mode	Low Channel	Middle Channel	High Channel
BLE(GFSK)	2402MHz	2440MHz	2480MHz

Note:

1..In radiated measurement,the EUT had been pre-scan on the positioned of each 3 axis(X,Y,Z), the worst case was found when positioned on X-plane.

4.3 Description of Support Units

The EUT has been tested with associated equipment below.

Description	Manufacturer	Model No.	Remark	FCC certification
N/A	N/A	N/A	N/A	N/A

4.4 Test Location

All tests were performed at:

Shenzhen Huaxia Testing Technology Co., Ltd.,

1F., Block A of Tongsheng Technology Building, Huahui Road, Dalang Street, Longhua New District, Shenzhen, Guangdong, China

4.5 Test Facility

The test facility is recognized, certified, or accredited by the following organizations:

• **CNAS (No. CNAS L5785)**

CNAS has accredited Shenzhen Huaxia Testing Technology Co., Ltd. Shenzhen Branch EMC Lab to ISO/IEC 17025:2005 General Requirements for the Competence of Testing and Calibration Laboratories (CNAS-CL01 Accreditation Criteria for the Competence of Testing and Calibration Laboratories) for the competence in the field of testing.

• **ISED Registration No.: 22984-1**

The 3m Semi-anechoic chamber of Shenzhen Huaxia Testing Technology Co., Ltd. has been registered by Certification and Engineering Bureau of Industry Canada for radio equipment testing

• **A2LA (Certificate No. 4742.01)**

Shenzhen Huaxia Testing Technology Co., Ltd., Shenzhen EMC Laboratory is accredited by the American Association for Laboratory Accreditation(A2LA). Certificate No. 4742.01.

• **FCC Registration No.: 522263**

Shenzhen Huaxia Testing Technology Co., Ltd., Shenzhen EMC Laboratory has been registered and fully described in a report filed with the (FCC) Federal Communications Commission. The acceptance letter from the FCC is maintained in our files. Registration No.:522263

4.6 Statement of the measurement uncertainty

The data and results referenced in this document are true and accurate.

The reader is cautioned that there may be errors within the calibration limits of the equipment and facilities.

The measurement uncertainty was calculated for all measurements listed in this test report acc. to CISPR 16 - 4 „Specification for radio disturbance and immunity measuring apparatus and methods – Part 4: Uncertainty in EMC Measurements“ and is documented in the **Shenzhen Huaxia Testing Technology Co., Ltd.** quality system acc. to DIN EN ISO/IEC 17025.

Furthermore, component and process variability of devices similar to that tested may result in additional deviation. The manufacturer has the sole responsibility of continued compliance of the device.

Hereafter the best measurement capability for CQA laboratory is reported:

No.	Item	Uncertainty	Notes
1	Radiated Emission (Below 1GHz)	5.12dB	(1)
2	Radiated Emission (Above 1GHz)	4.60dB	(1)
3	Conducted Disturbance (0.15~30MHz)	3.34dB	(1)
4	Radio Frequency	3×10^{-8}	(1)
5	Duty cycle	0.6 %.	(1)
6	Occupied Bandwidth	1.1%	(1)
7	RF conducted power	0.86dB	(1)
8	RF power density	0.74	(1)
9	Conducted Spurious emissions	0.86dB	(1)
10	Temperature test	0.8°C	(1)
11	Humidity test	2.0%	(1)
12	Supply voltages	0.5 %.	(1)
13	Frequency Error	5.5 Hz	(1)

(1) This uncertainty represents an expanded uncertainty expressed at approximately the 95% confidence level using a coverage factor of k=2.

4.7 Deviation from Standards

None.

4.8 Abnormalities from Standard Conditions

None.

4.9 Other Information Requested by the Customer

None.

4.10 Equipment List

Test Equipment	Manufacturer	Model No.	Instrument No.	Calibration Date	Calibration Due Date
EMI Test Receiver	R&S	ESR7	CQA-005	2019/10/25	2020/10/24
Spectrum analyzer	R&S	FSU26	CQA-038	2019/10/25	2020/10/24
Preamplifier	MITEQ	AMF-6D-02001800-29-20P	CQA-036	2019/10/25	2020/10/24
Loop antenna	Schwarzbeck	FMZB1516	CQA-087	2019/10/21	2020/10/20
Bilog Antenna	R&S	HL562	CQA-011	2019/9/26	2020/9/25
Horn Antenna	R&S	HF906	CQA-012	2019/9/26	2020/9/25
Horn Antenna	Schwarzbeck	BBHA 9170	CQA-088	2019/9/25	2020/9/24
Coaxial Cable (Above 1GHz)	CQA	N/A	C007	2019/9/26	2020/9/25
Coaxial Cable (Below 1GHz)	CQA	N/A	C013	2019/9/26	2020/9/25
Antenna Connector	CQA	RFC-01	CQA-080	2019/9/26	2020/9/25
Power Sensor	KEYSIGHT	U2021XA	CQA-30	2019/9/26	2020/9/25
N1918A Power Analysis Manager Power Panel	Agilent	N1918A	CQA-074	2019/9/26	2020/9/25
Power divider	MIDWEST	PWD-2533-02-SMA-79	CQA-067	2019/9/26	2020/9/25
EMI Test Receiver	R&S	ESPI3	CQA-013	2019/9/26	2020/9/25
LISN	R&S	ENV216	CQA-003	2019/10/23	2020/10/22
Coaxial cable	CQA	N/A	CQA-C009	2019/9/26	2020/9/25

Note:

The temporary antenna connector is soldered on the PCB board in order to perform conducted tests and this temporary antenna connector is listed in the equipment list.

5 Test results and Measurement Data

5.1 Antenna Requirement

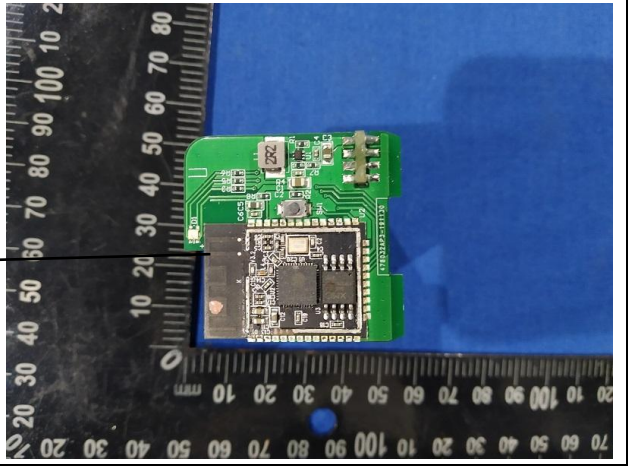
Standard requirement:	47 CFR Part 15C Section 15.203 /247(c)
<p>15.203 requirement: An intentional radiator shall be designed to ensure that no antenna other than that furnished by the responsible party shall be used with the device. The use of a permanently attached antenna or of an antenna that uses a unique coupling to the intentional radiator, the manufacturer may design the unit so that a broken antenna can be replaced by the user, but the use of a standard antenna jack or electrical connector is prohibited.</p> <p>15.247(b) (4) requirement: The conducted output power limit specified in paragraph (b) of this section is based on the use of antennas with directional gains that do not exceed 6 dBi. Except as shown in paragraph (c) of this section, if transmitting antennas of directional gain greater than 6 dBi are used, the conducted output power from the intentional radiator shall be reduced below the stated values in paragraphs (b)(1), (b)(2), and (b)(3) of this section, as appropriate, by the amount in dB that the directional gain of the antenna exceeds 6 dBi.</p>	
EUT Antenna:	<div style="display: flex; align-items: center;"> <div style="border: 1px solid black; padding: 5px; margin-right: 10px;"> WIFI/BT Antenna </div>  </div>
<p>The antenna is a PCB antenna. Antenna Gain : 0dBi</p>	

Duty cycle:

Test mode	On time(ms)	Total time(ms)	Duty Cycle	Duty Factor
BLE(GFSK) –TX 2440MHz	0.41739	0.62319	66.98%	1.74

Note:

1. If duty cycle <98 %, the conducted average output power and average power spectral density should be add duty factor.
2. If duty cycle ≥98 %, the EUT is consider to be transmitting continuously, the conducted average output power and average power spectral density no need to add duty factor (consider to be zero).
3. The conducted peak output power and peak power spectral density no need to consider duty factor.
4. The on-time time is transmission duration(T).

GFSK 2440

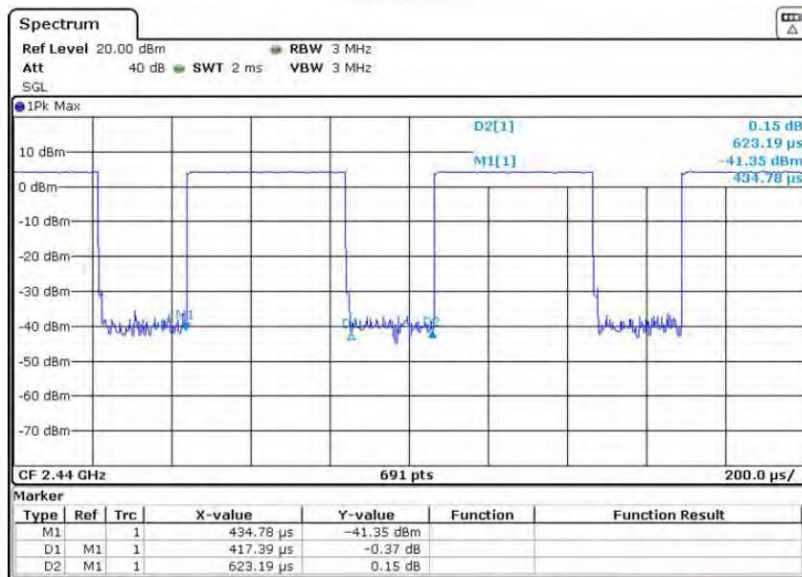

5.2 Conducted Emissions

Test Requirement:	47 CFR Part 15C Section 15.207,		
Test Method:	ANSI C63.10: 2013		
Test Frequency Range:	150kHz to 30MHz		
Limit:	Frequency range (MHz)	Limit (dBuV)	
		Quasi-peak	Average
	0.15-0.5	66 to 56*	56 to 46*
	0.5-5	56	46
	5-30	60	50
* Decreases with the logarithm of the frequency.			
Test Procedure:	<ol style="list-style-type: none"> 1) The mains terminal disturbance voltage test was conducted in a shielded room. 2) The EUT was connected to AC power source through a LISN 1 (Line Impedance Stabilization Network) which provides a $50\Omega/50\mu\text{H} + 5\Omega$ linear impedance. The power cables of all other units of the EUT were connected to a second LISN 2, which was bonded to the ground reference plane in the same way as the LISN 1 for the unit being measured. A multiple socket outlet strip was used to connect multiple power cables to a single LISN provided the rating of the LISN was not exceeded. 3) The tabletop EUT was placed upon a non-metallic table 0.8m above the ground reference plane. And for floor-standing arrangement, the EUT was placed on the horizontal ground reference plane, 4) The test was performed with a vertical ground reference plane. The rear of the EUT shall be 0.4 m from the vertical ground reference plane. The vertical ground reference plane was bonded to the horizontal ground reference plane. The LISN 1 was placed 0.8 m from the boundary of the unit under test and bonded to a ground reference plane for LISNs mounted on top of the ground reference plane. This distance was between the closest points of the LISN 1 and the EUT. All other units of the EUT and associated equipment was at least 0.8 m from the LISN 2. 5) In order to find the maximum emission, the relative positions of equipment and all of the interface cables must be changed according to ANSI C63.10: 2013 on conducted measurement. 		

<p>Test Setup:</p>	<p>The diagram illustrates the test setup within a shielding room. It shows a table with an EUT (Equipment Under Test) and an AE (Antenna) on top. A Test Receiver is positioned on a separate table to the right. LISN1 (Line Impedance Stabilization Network) is connected to AC Mains on the left, and LISN2 is connected to AC Mains on the right. A Ground Reference Plane is shown at the bottom. A vertical dimension of 80cm is indicated between the table surface and the ground plane. A diagonal dimension of 80cm is shown between LISN1 and the EUT/AE setup.</p>
<p>Exploratory Test Mode:</p>	<p>Transmitting with all kind of modulations, data rates</p>
<p>Final Test Mode:</p>	<p>Through Pre-scan, find at lowest channel is the worst case. Only the worst case is recorded in the report.</p>
<p>Test Voltage:</p>	<p>AC120V/60Hz</p>
<p>Test Results:</p>	<p>Pass</p>

Measurement Data:

Live Line:

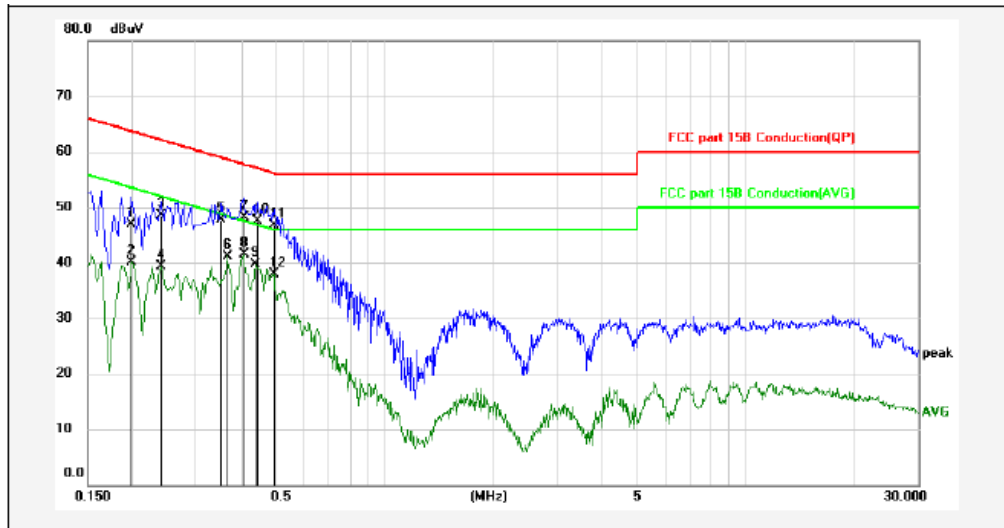

No.	Frequency (MHz)	Reading (dBuV)	Lisn/Isn (dB)	Cab_L (dB)	Result (dBuV)	Limit dBuV	Margin (dB)	Detector	Remark
1	0.1995	37.17	9.6	0.23	47.00	63.63	-16.63	QP	
2	0.1995	30.36	9.6	0.23	40.19	53.63	-13.44	AVG	
3	0.2400	38.67	9.6	0.23	48.50	62.10	-13.60	QP	
4	0.2400	29.54	9.6	0.23	39.37	52.10	-12.73	AVG	
5	0.3525	37.87	9.59	0.24	47.70	58.90	-11.20	QP	
6	0.3660	31.37	9.59	0.24	41.20	48.59	-7.39	AVG	
7	0.4065	38.38	9.58	0.24	48.20	57.72	-9.52	QP	
8	0.4065	31.77	9.58	0.24	41.59	47.72	-6.13	AVG	
9	0.4380	29.79	9.58	0.24	39.61	47.10	-7.49	AVG	
10	0.4425	37.78	9.58	0.24	47.60	57.01	-9.41	QP	
11	0.4920	36.99	9.57	0.24	46.80	56.13	-9.33	QP	
12	0.4920	28.17	9.57	0.24	37.98	46.13	-8.15	AVG	

Remarks: 1. Result=Reading+Lisn+Cab_L

2. If the average limit is met when using a quasi-peak detector, the EUT shall be deemed to meet both limits and measurement with average detector is unnecessary.

Neutral Line:

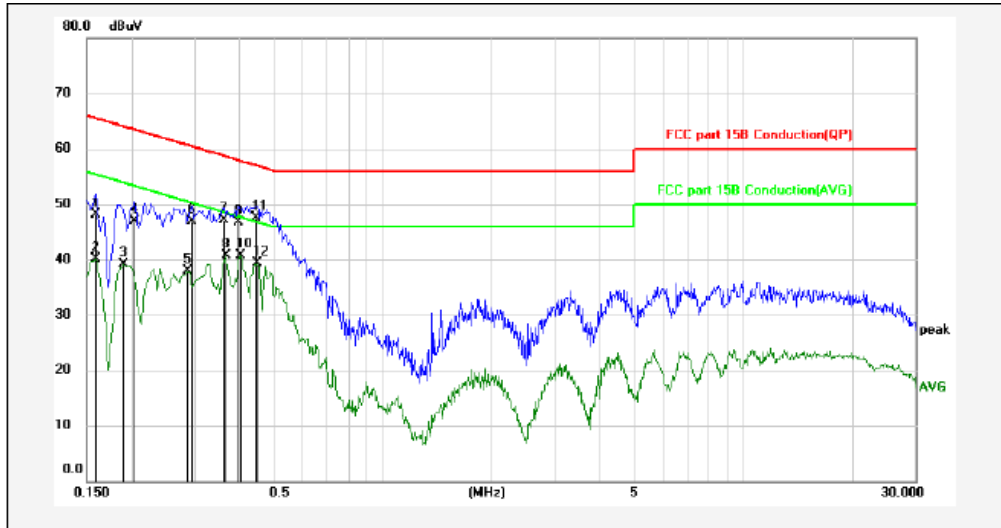

No.	Frequency (MHz)	Reading (dBuV)	Lisn/Isn (dB)	Cab_L (dB)	Result (dBuV)	Limit dBuV	Margin (dB)	Detector	Remark
1	0.1590	38.38	9.6	0.22	48.20	65.52	-17.32	QP	
2	0.1590	30.25	9.6	0.22	40.07	55.52	-15.45	AVG	
3	0.1905	29.22	9.6	0.23	39.05	54.01	-14.96	AVG	
4	0.2040	37.17	9.6	0.23	47.00	63.45	-16.45	QP	
5	0.2850	27.98	9.6	0.24	37.82	50.67	-12.85	AVG	
6	0.2940	37.06	9.6	0.24	46.90	60.41	-13.51	QP	
7	0.3615	37.37	9.59	0.24	47.20	58.69	-11.49	QP	
8	0.3660	30.79	9.59	0.24	40.62	48.59	-7.97	AVG	
9	0.3975	36.87	9.59	0.24	46.70	57.91	-11.21	QP	
10	0.4020	30.87	9.59	0.24	40.70	47.81	-7.11	AVG	
11	0.4425	37.68	9.58	0.24	47.50	57.01	-9.51	QP	
12	0.4470	29.39	9.58	0.24	39.21	46.93	-7.72	AVG	

Remarks: 1. Result=Reading+Lisn+Cab_L
 2. If the average limit is met when using a quasi-peak detector, the EUT shall be deemed to meet both limits and measurement with average detector is unnecessary.

5.3 Conducted Peak Output Power

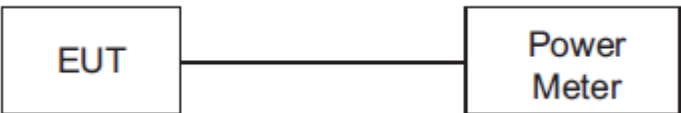
Test Requirement:	47 CFR Part 15C Section 15.247 (b)(3)
Test Method:	ANSI C63.10: 2013
Test Setup:	 <p>1, Connected the EUT's antenna port to spectrum analyzer device. 2, Follow the test procedure as described in KDB 558074 (1). Set the RBW \geq DTS bandwidth. (2). Set VBW \geq 3 x RBW. (3). Set span \geq 3 x RBW. (4). Sweep time = auto couple. (5). Detector = peak. (6). Trace mode = max hold. (7). Allow trace to fully stabilize. (8). Use peak marker function to determine the peak amplitude level. Note: The cable loss and attenuator loss were offset into measure device as an amplitude offs</p>
Exploratory Test Mode:	Transmitting with all kind of modulations, data rates
Final Test Mode:	BLE(GFSK)
Limit:	30dBm
Test Results:	Pass

Measurement Data

Test Mode	CH	Conducted Power (dBm)	Duty Factor	Result (dBm)	Limit (dBm)
BLE(GFSK)	CH1	0.30	1.74	2.04	30
	CH20	1.27	1.74	3.01	30
	CH40	2.78	1.74	4.52	30
Conclusion: PASS					

5.4 6dB Occupy Bandwidth

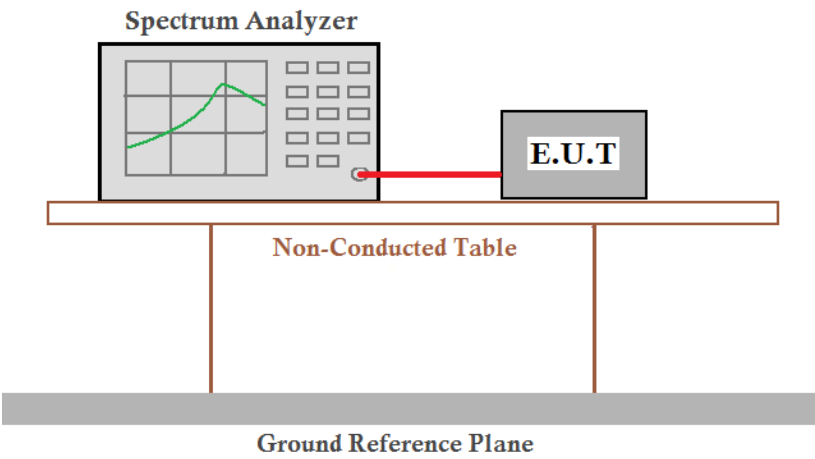
Test Requirement:	47 CFR Part 15C Section 15.247 (a)(2)
Test Method:	ANSI C63.10: 2013
Test Setup:	 <p style="text-align: center;">Spectrum Analyzer</p> <p style="text-align: center;">E.U.T</p> <p style="text-align: center;">Non-Conducted Table</p> <p style="text-align: center;">Ground Reference Plane</p> <ol style="list-style-type: none"> 1, Connected the EUT's antenna port to spectrum analyzer device. 2, Follow the test procedure as described in KDB 558074 <ol style="list-style-type: none"> (1). Set resolution bandwidth (RBW) = 100 kHz. (2). Set the video bandwidth (VBW) $\geq 3 \times$ RBW. (3). Detector = Peak. (4). Trace mode = max hold. (5). Sweep = auto couple. (6). Allow the trace to stabilize. (7). Measure the maximum width of the emission that is constrained by the frequencies associated with the two outermost amplitude points (upper and lower) that are attenuated by 6 dB relative to the maximum level measured in the fundamental emission.
Exploratory Test Mode:	Transmitting with all kind of modulations, data rates
Final Test Mode:	BLE(GFSK)
Limit:	≥ 500 kHz
Test Results:	Pass

Measurement Data

Test Mode	CH	6dB bandwidth (MHz)	Limit (KHz)
BLE(GFSK)	CH1	0.755	>500
	CH20	0.762	>500
	CH40	0.756	>500
Conclusion: PASS			

Test plot as follows:

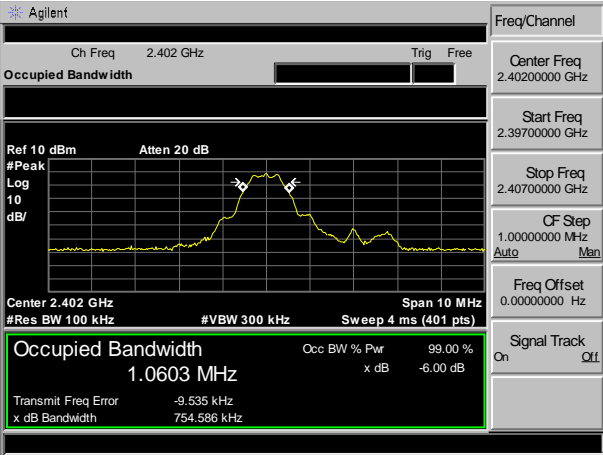
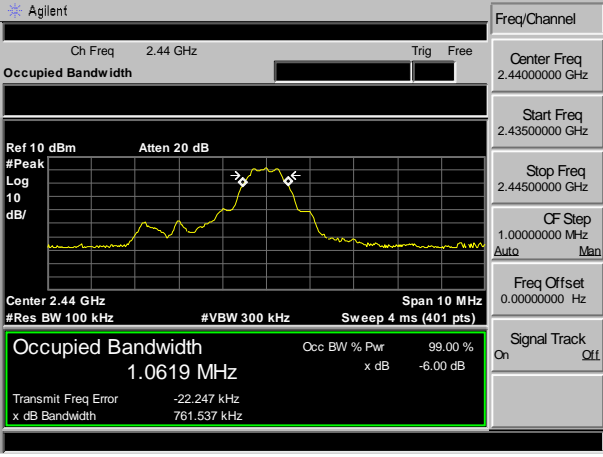
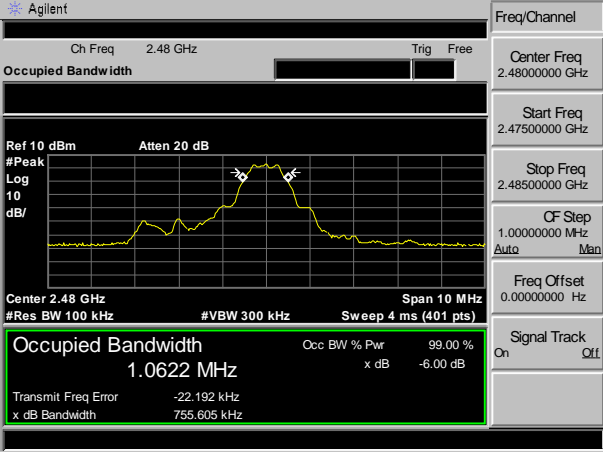
Graphs_6dB Occupy Bandwidth	
<p>BLE(GFSK) 2402MHz</p>	 <p>Agilent Freq/Channel</p> <p>Ch Freq 2.402 GHz Trig Free</p> <p>Center Freq 2.4020000 GHz</p> <p>Start Freq 2.3970000 GHz</p> <p>Stop Freq 2.4070000 GHz</p> <p>CF Step 1.0000000 MHz Auto Man</p> <p>Freq Offset 0.0000000 Hz</p> <p>Signal Track On Off</p> <p>Ref 10 dBm Atten 20 dB</p> <p>#Peak Log 10 dB/</p> <p>Center 2.402 GHz Span 10 MHz</p> <p>#Res BW 100 kHz #VBW 300 kHz Sweep 4 ms (401 pts)</p> <p>Occupied Bandwidth 1.0603 MHz</p> <p>Occ BW % Pwr 99.00 % x dB -6.00 dB</p> <p>Transmit Freq Error -9.535 kHz</p> <p>x dB Bandwidth 754.586 kHz</p>
<p>BLE(GFSK) 2440MHz</p>	 <p>Agilent Freq/Channel</p> <p>Ch Freq 2.44 GHz Trig Free</p> <p>Center Freq 2.4400000 GHz</p> <p>Start Freq 2.4350000 GHz</p> <p>Stop Freq 2.4450000 GHz</p> <p>CF Step 1.0000000 MHz Auto Man</p> <p>Freq Offset 0.0000000 Hz</p> <p>Signal Track On Off</p> <p>Ref 10 dBm Atten 20 dB</p> <p>#Peak Log 10 dB/</p> <p>Center 2.44 GHz Span 10 MHz</p> <p>#Res BW 100 kHz #VBW 300 kHz Sweep 4 ms (401 pts)</p> <p>Occupied Bandwidth 1.0619 MHz</p> <p>Occ BW % Pwr 99.00 % x dB -6.00 dB</p> <p>Transmit Freq Error -22.247 kHz</p> <p>x dB Bandwidth 761.537 kHz</p>
<p>BLE(GFSK) 2480MHz</p>	 <p>Agilent Freq/Channel</p> <p>Ch Freq 2.48 GHz Trig Free</p> <p>Center Freq 2.4800000 GHz</p> <p>Start Freq 2.4750000 GHz</p> <p>Stop Freq 2.4850000 GHz</p> <p>CF Step 1.0000000 MHz Auto Man</p> <p>Freq Offset 0.0000000 Hz</p> <p>Signal Track On Off</p> <p>Ref 10 dBm Atten 20 dB</p> <p>#Peak Log 10 dB/</p> <p>Center 2.48 GHz Span 10 MHz</p> <p>#Res BW 100 kHz #VBW 300 kHz Sweep 4 ms (401 pts)</p> <p>Occupied Bandwidth 1.0622 MHz</p> <p>Occ BW % Pwr 99.00 % x dB -6.00 dB</p> <p>Transmit Freq Error -22.192 kHz</p> <p>x dB Bandwidth 755.605 kHz</p>

5.5 Power Spectral Density

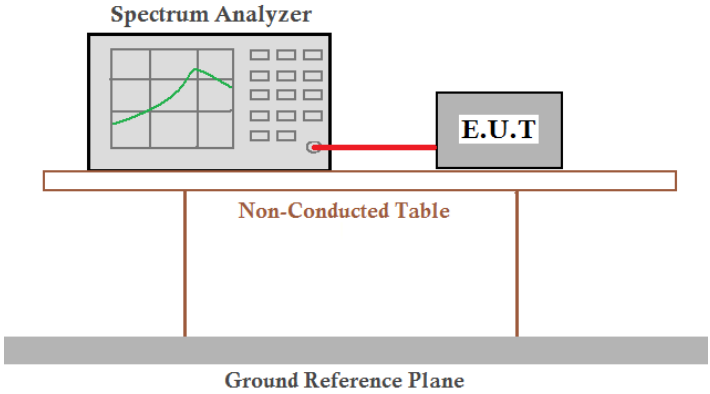
Test Requirement:	47 CFR Part 15C Section 15.247 (e)
Test Method:	ANSI C63.10: 2013
Test Setup:	 <p>1, Connected the EUT's antenna port to spectrum analyzer device. 2, Follow the test procedure as described in KDB 558074 (1). Set analyzer center frequency to DTS channel center frequency. (2). Set the span to 1.5 times the DTS bandwidth. (3). Set the RBW to: $3 \text{ kHz} \leq \text{RBW} \leq 100 \text{ kHz}$. (4). Set the VBW $\geq 3 \text{ RBW}$. (5). Detector = peak. (6). Sweep time = auto couple. (7). Trace mode = max hold. (8). Allow trace to fully stabilize. (9). Use the peak marker function to determine the maximum amplitude level. (10). If measured value exceeds limit, reduce RBW (no less than 3 kHz) and repeat.</p>
Exploratory Test Mode:	Transmitting with all kind of modulations, data rates
Final Test Mode:	BLE(GFSK)
Limit:	$\leq 8.00 \text{ dBm/3kHz}$
Test Results:	Pass

Measurement Data

Test Mode	CH	Power density (dBm/3kHz)	Duty Factor	Result (dBm/3kHz)	(dBm/3kHz) Limit Limit
GFSK(BLE)	CH1	-16.26	1.74	-14.49	8
	CH20	-13.18	1.74	-11.44	8
	CH40	-11.83	1.74	-10.09	8
Conclusion: PASS					

Test plot as follows:

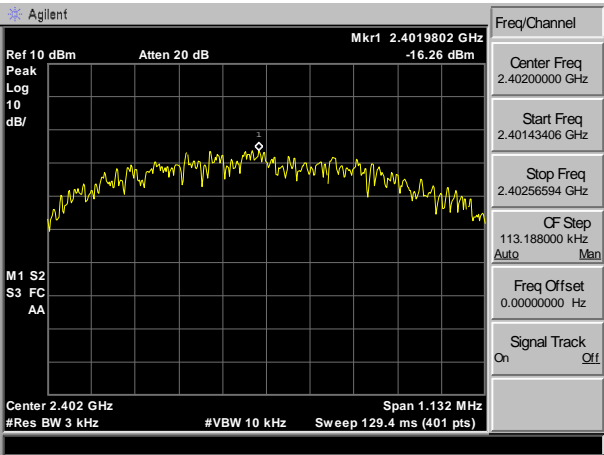
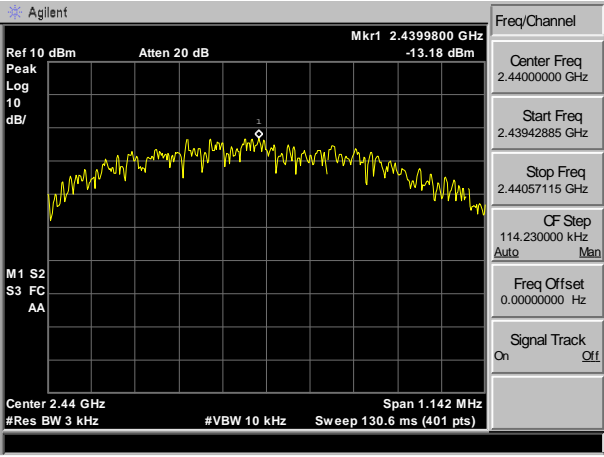
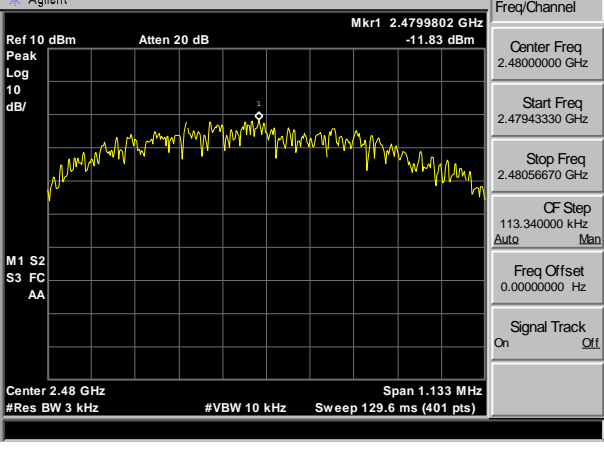
Graphs	
<p>BLE(GFSK) 2402MHz</p>	
<p>BLE(GFSK) 2440MHz</p>	
<p>BLE(GFSK) 2480MHz</p>	

5.6 Radiated Spurious Emissions

Test Requirement:	47 CFR Part 15C Section 15.209 and 15.205				
Test Method:	ANSI C63.10 2013				
Test Site:	Measurement Distance: 3m (Semi-Anechoic Chamber)				
Receiver Setup:	Frequency	Detector	RBW	VBW	Remark
	0.009MHz-0.090MHz	Peak	10kHz	30kHz	Peak
	0.009MHz-0.090MHz	Average	10kHz	30kHz	Average
	0.090MHz-0.110MHz	Quasi-peak	10kHz	30kHz	Quasi-peak
	0.110MHz-0.490MHz	Peak	10kHz	30kHz	Peak
	0.110MHz-0.490MHz	Average	10kHz	30kHz	Average
	0.490MHz -30MHz	Quasi-peak	10kHz	30kHz	Quasi-peak
	30MHz-1GHz	Quasi-peak	100 kHz	300kHz	Quasi-peak
	Above 1GHz	Peak	1MHz	3MHz	Peak
Peak		1MHz	10Hz	Average	
Limit:	Frequency	Field strength (microvolt/meter)	Limit (dBuV/m)	Remark	Measurement distance (m)
	0.009MHz-0.490MHz	2400/F(kHz)	-	-	300
	0.490MHz-1.705MHz	24000/F(kHz)	-	-	30
	1.705MHz-30MHz	30	-	-	30
	30MHz-88MHz	100	40.0	Quasi-peak	3
	88MHz-216MHz	150	43.5	Quasi-peak	3
	216MHz-960MHz	200	46.0	Quasi-peak	3
	960MHz-1GHz	500	54.0	Quasi-peak	3
	Above 1GHz	500	54.0	Average	3
<p>Note: 15.35(b), Unless otherwise specified, the limit on peak radio frequency emissions is 20dB above the maximum permitted average emission limit applicable to the equipment under test. This peak limit applies to the total peak emission level radiated by the device.</p>					

Test Setup:

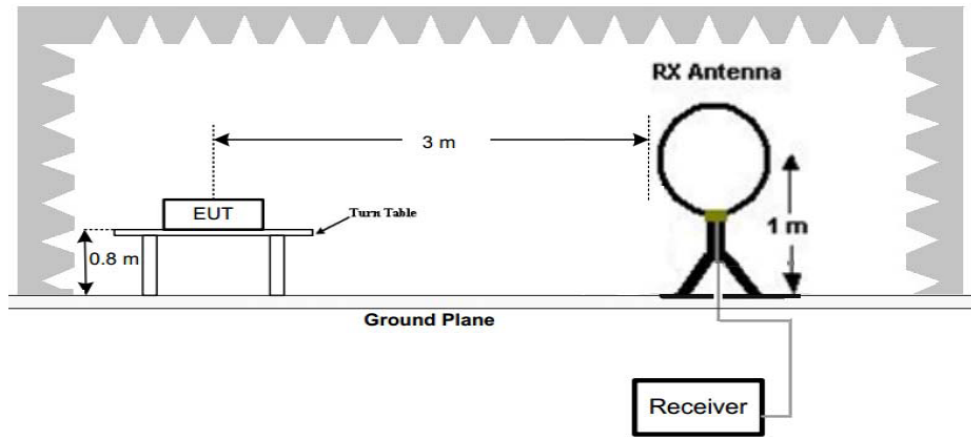

Figure 1. Below 30MHz

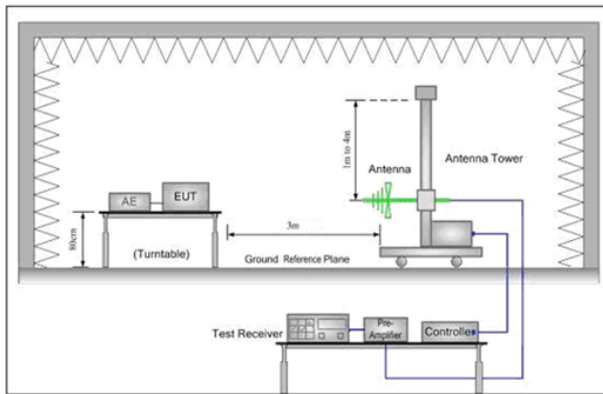

Figure 2. 30MHz to 1GHz

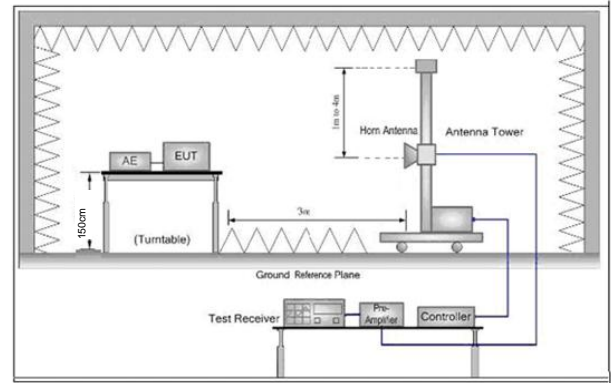

Figure 3. Above 1 GHz

<p>Test Procedure:</p>	<ol style="list-style-type: none"> a. 1) Below 1G: The EUT was placed on the top of a rotating table 0.8 meters above the ground at a 3 meter semi-anechoic chamber. The table was rotated 360 degrees to determine the position of the highest radiation. 2) Above 1G: The EUT was placed on the top of a rotating table 1.5 meters above the ground at a 3 meter semi-anechoic chamber. The table was rotated 360 degrees to determine the position of the highest radiation. <p>Note: For the radiated emission test above 1GHz: Place the measurement antenna away from each area of the EUT determined to be a source of emissions at the specified measurement distance, while keeping the measurement antenna aimed at the source of emissions at each frequency of significant emissions, with polarization oriented for maximum response. The measurement antenna may have to be higher or lower than the EUT, depending on the radiation pattern of the emission and staying aimed at the emission source for receiving the maximum signal. The final measurement antenna elevation shall be that which maximizes the emissions. The measurement antenna elevation for maximum emissions shall be restricted to a range of heights of from 1 m to 4 m above the ground or reference ground plane.</p> <ol style="list-style-type: none"> b. The EUT was set 3 meters away from the interference-receiving antenna, which was mounted on the top of a variable-height antenna tower. c. The antenna height is varied from one meter to four meters above the ground to determine the maximum value of the field strength. Both horizontal and vertical polarizations of the antenna are set to make the measurement. d. For each suspected emission, the EUT was arranged to its worst case and then the antenna was tuned to heights from 1 meter to 4 meters (for
------------------------	---

	<p>the test frequency of below 30MHz, the antenna was tuned to heights 1 meter) and the rotatable table was turned from 0 degrees to 360 degrees to find the maximum reading.</p> <p>e. The test-receiver system was set to Peak Detect Function and Specified Bandwidth with Maximum Hold Mode.</p> <p>f. If the emission level of the EUT in peak mode was 10dB lower than the limit specified, then testing could be stopped and the peak values of the EUT would be reported. Otherwise the emissions that did not have 10dB margin would be re-tested one by one using peak, quasi-peak or average method as specified and then reported in a data sheet.</p> <p>g. Test the EUT in the lowest channel ,the middle channel ,the Highest channel</p> <p>h. Repeat above procedures until all frequencies measured was complete.</p>
Exploratory Test Mode:	<p>Transmitting with all kind of modulations, data rates. Transmitting mode.</p>
Final Test Mode:	<p>BLE(GFSK) Only the worst case is recorded in the report.</p>
Test Results:	<p>Pass</p>

5.6.1 Radiated emission below 1GHz

30MHz~1GHz		
Test mode:	Transmitting	Vertical

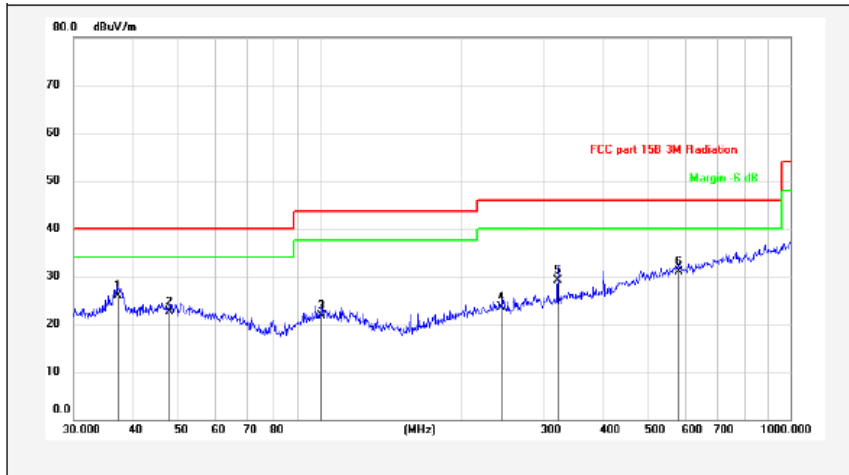

No.	Frequency (MHz)	Reading (dBuV/m)	Antenna (dB/m)	Cable (dB)	Result (dBuV/m)	Limit (dBuV/m)	Margin (dB)	Detector
1	37.2855	12.73	12.35	0.92	26.00	40.00	-14.00	QP
2	47.9938	7.43	14.1	1.07	22.60	40.00	-17.40	QP
3	100.9338	7.69	12.66	1.45	21.80	43.50	-21.70	QP
4	243.3771	9.04	12.33	2.23	23.60	46.00	-22.40	QP
5	319.9370	13.19	13.4	2.51	29.10	46.00	-16.90	QP
6	578.6698	9.41	18.09	3.5	31.00	46.00	-15.00	QP

Remarks: 1. Result=Reading+Antenna+Cable
 2. If Peak Result complies with QP Limit, QP Result is deemed to comply with QP Limit.

Test mode:	Transmitting	Horizontal
------------	--------------	------------

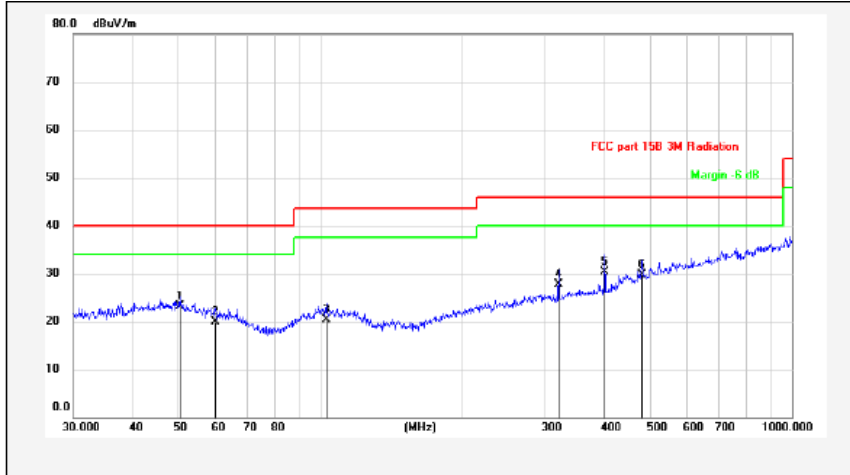

No.	Frequency (MHz)	Reading (dBuV/m)	Antenna (dB/m)	Cable (dB)	Result (dBuV/m)	Limit (dBuV/m)	Margin (dB)	Detector
1	50.4089	7.97	14.04	1.09	23.10	40.00	-16.90	QP
2	60.0690	6.83	12	1.17	20.00	40.00	-20.00	QP
3	103.0800	6.23	12.58	1.49	20.30	43.50	-23.20	QP
4	319.9370	11.79	13.4	2.51	27.70	46.00	-18.30	QP
5	400.4318	13.19	14.41	2.8	30.40	46.00	-15.60	QP
6	480.5276	9.48	17.09	3.13	29.70	46.00	-16.30	QP

Remarks: 1. Result=Reading+Antenna+Cable
 2. If Peak Result complies with QP Limit, QP Result is deemed to comply with QP Limit.

5.6.2 Transmitter emission above 1GHz

Test mode: BLE(GFSK)		2402MHz		Test channel:		Lowest	
Frequency	Meter Reading	Factor	Emission Level	Limits	Over	Detector Type	Ant. Pol.
(MHz)	(dBμV)	(dB)	(dBμV/m)	(dBμV/m)	(dB)		H/V
4804.000	59.60	-4.12	55.48	74	-18.48	peak	H
4804.000	43.36	-4.12	39.14	54	-14.86	AVG	H
7206.000	49.55	1.46	51.01	74	-22.99	peak	H
7206.000	35.19	1.46	36.65	54	-17.35	AVG	H
4804.000	59.41	-4.12	55.29	74	-18.71	peak	V
4804.000	43.11	-4.12	38.99	54	-15.01	AVG	V
7206.000	48.59	1.46	50.05	74	-23.95	peak	V
7206.000	35.99	1.46	37.44	54	-16.56	AVG	V

Test mode: BLE(GFSK)		2440MHz		Test channel:		Middle	
Frequency	Meter Reading	Factor	Emission Level	Limits	Over	Detector Type	Ant. Pol.
(MHz)	(dBμV)	(dB)	(dBμV/m)	(dBμV/m)	(dB)		H/V
4880.000	59.55	-4.03	55.52	74	-18.48	peak	H
4880.000	45.93	-4.03	41.90	54	-12.10	AVG	H
7320.000	51.66	1.66	53.32	74	-20.68	peak	H
7320.000	36.97	1.66	38.63	54	-15.37	AVG	H
4880.000	61.00	-4.03	56.97	74	-17.03	peak	V
4880.000	45.88	-4.03	41.85	54	-12.15	AVG	V
7320.000	49.96	1.66	51.62	74	-22.38	peak	V
7320.000	36.87	1.66	38.53	54	-15.47	AVG	V

Test mode: BLE(GFSK)		2480MHz		Test channel:		Highest	
Frequency	Meter Reading	Factor	Emission Level	Limits	Over	Detector Type	Ant. Pol.
(MHz)	(dBμV)	(dB)	(dBμV/m)	(dBμV/m)	(dB)		H/V
4960.000	60.54	-4.26	56.28	74	-17.72	peak	H
4960.000	43.55	-4.26	39.29	54	-14.71	AVG	H
7440.000	51.00	1.18	52.22	74	-21.70	peak	H
7440.000	37.90	1.18	39.08	54	-14.92	AVG	H
4960.000	62.79	-4.26	58.53	74	-15.47	peak	V
4960.000	46.80	-4.26	42.54	54	-11.40	AVG	V
7440.000	50.41	1.18	51.59	74	-22.41	peak	V
7440.000	36.80	1.18	37.98	54	-16.02	AVG	V

Remark:

1) The field strength is calculated by adding the Antenna Factor, Cable Factor & Preamplifier. The basic equation with a sample calculation is as follows:

$$\text{Final Test Level} = \text{Receiver Reading} + \text{Antenna Factor} + \text{Cable Factor} - \text{Preamplifier Factor}$$

2) Scan from 9kHz to 25GHz, The disturbance above 13GHz and below 30MHz was very low, and the above harmonics were the highest point could be found when testing, so only the above harmonics had been displayed. The amplitude of spurious emissions from the radiator which are attenuated more than 20dB below the limit need not be reported.

5.7 Restricted bands around fundamental frequency

Test Requirement:	47 CFR Part 15C Section 15.209 and 15.205		
Test Method:	ANSI C63.10 2013		
Test Site:	Measurement Distance: 3m (Semi-Anechoic Chamber)		
Limit:	Frequency	Limit (dBuV/m @3m)	Remark
	30MHz-88MHz	40.0	Quasi-peak Value
	88MHz-216MHz	43.5	Quasi-peak Value
	216MHz-960MHz	46.0	Quasi-peak Value
	960MHz-1GHz	54.0	Quasi-peak Value
	Above 1GHz	54.0	Average Value
		74.0	Peak Value

Test Setup:

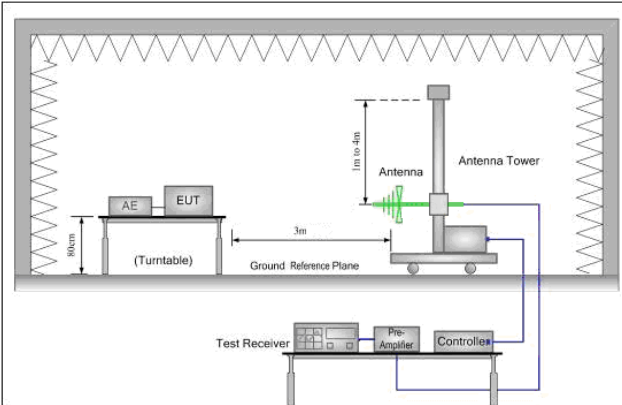

Figure 1. 30MHz to 1GHz

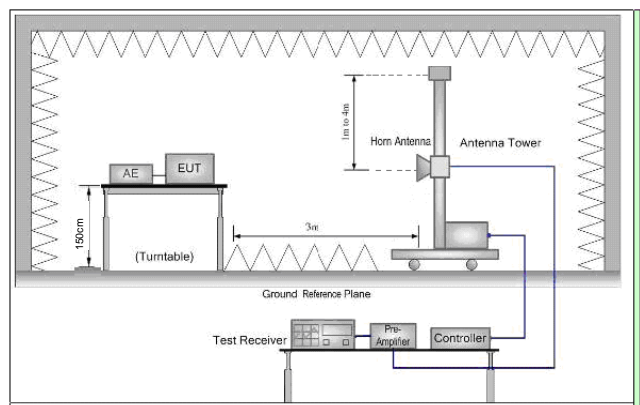

Figure 2. Above 1 GHz

Test Procedure:	<p>a. 1) Below 1G: The EUT was placed on the top of a rotating table 0.8 meters above the ground at a 3 meter semi-anechoic chamber. The table was rotated 360 degrees to determine the position of the highest radiation.</p> <p>2) Above 1G: The EUT was placed on the top of a rotating table 1.5 meters above the ground at a 3 meter semi-anechoic chamber. The table was rotated 360 degrees to determine the position of the highest radiation.</p> <p>Note: For the radiated emission test above 1GHz:</p> <p>Place the measurement antenna away from each area of the EUT determined to be a source of emissions at the specified measurement distance, while keeping the measurement antenna aimed at the source of emissions at each frequency of significant emissions, with polarization oriented for maximum response. The measurement antenna may have to be higher or lower than the EUT, depending on the radiation pattern of the emission and staying aimed at the emission source for receiving the maximum signal. The final measurement antenna elevation shall be that which maximizes the emissions. The measurement antenna elevation for maximum emissions shall be restricted to a range of heights of from 1 m to 4 m above the ground or reference ground plane.</p> <p>b. The EUT was set 3 meters away from the interference-receiving antenna, which was mounted on the top of a variable-height antenna tower.</p> <p>c. The antenna height is varied from one meter to four meters above the ground to determine the maximum value of the field strength. Both horizontal and vertical polarizations of the antenna are set to make the measurement.</p>
-----------------	--

	<ul style="list-style-type: none"> d. For each suspected emission, the EUT was arranged to its worst case and then the antenna was tuned to heights from 1 meter to 4 meters and the rotatable table was turned from 0 degrees to 360 degrees to find the maximum reading. e. The test-receiver system was set to Peak Detect Function and Specified Bandwidth with Maximum Hold Mode. f. Place a marker at the end of the restricted band closest to the transmit frequency to show compliance. Also measure any emissions in the restricted bands. Save the spectrum analyzer plot. Repeat for each power and modulation for lowest and highest channel g. Test the EUT in the lowest channel , the Highest channel h. Repeat above procedures until all frequencies measured was complete.
Exploratory Test Mode:	Transmitting with all kind of modulations, data rates. Transmitting mode.
Final Test Mode:	BLE(GFSK) Only the worst case is recorded in the report.
Test Results:	Pass

Test data:

Test mode: BLE(GFSK)	2402MHz	Test channel:	Lowest	Polarization	Horizontal
----------------------	---------	---------------	--------	--------------	------------

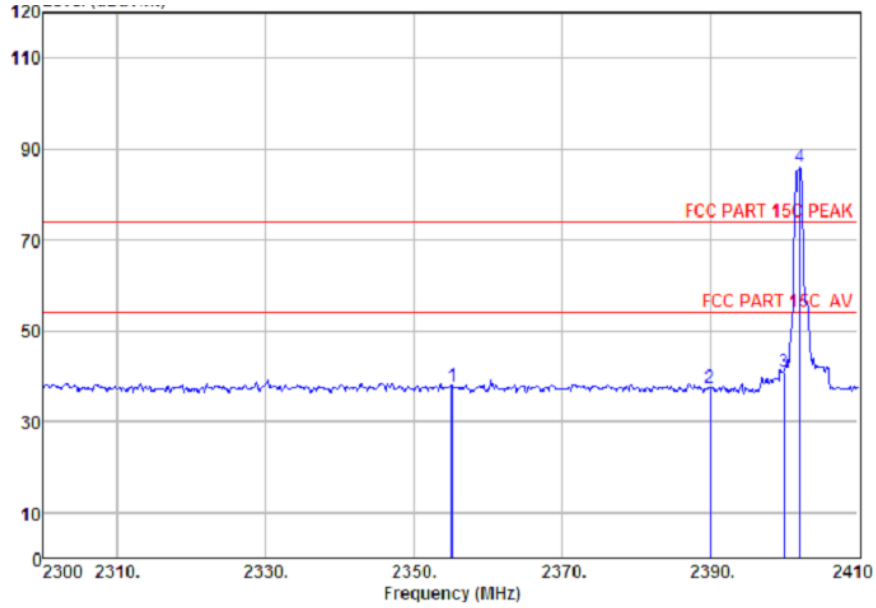

	Freq. (MHz)	Ant. Factor (dB/m)	Cable Loss (dB)	Amp Factor (dB)	Reading (dBuV)	Emission Level (dBuV/m)	Limits (dBuV/m)	Margin (dB)	Remark
1	2355.11	27.70	6.58	34.22	37.58	37.64	74.00	36.36	Peak
2	2390.00	27.64	6.62	34.19	37.33	37.40	74.00	36.60	Peak
3	2400.00	27.61	6.62	34.18	41.03	41.08	74.00	32.92	Peak
4	2402.08	27.61	6.62	34.18	86.05	86.10	74.00	-12.10	Peak

Remarks: 1. Emission Level= Antenna Factor + Cable Loss - Amp Factor + Reading.
 2. The emission levels that are 20dB below the official limit are not reported.

Test mode: BLE(GFSK)	2402MHz	Test channel:	Lowest	Polarization	Vertical
----------------------	---------	---------------	--------	--------------	----------

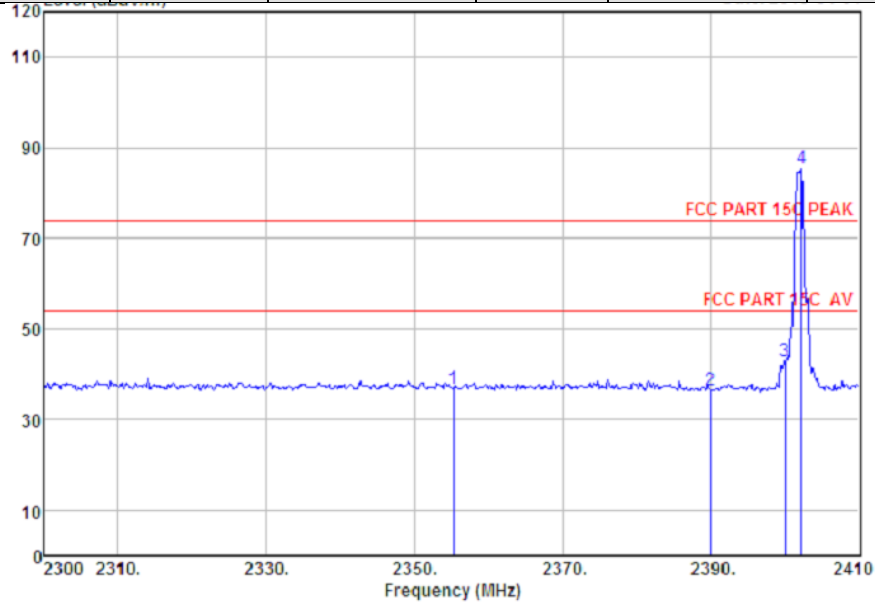

	Freq. (MHz)	Ant. Factor (dB/m)	Cable Loss (dB)	Amp Factor (dB)	Reading (dBuV)	Emission Level (dBuV/m)	Limits (dBuV/m)	Margin (dB)	Remark
1	2355.22	27.70	6.58	34.22	36.82	36.88	74.00	37.12	Peak
2	2390.00	27.64	6.62	34.19	36.40	36.47	74.00	37.53	Peak
3	2400.00	27.61	6.62	34.18	42.93	42.98	74.00	31.02	Peak
4	2402.30	27.61	6.62	34.18	85.23	85.28	74.00	-11.28	Peak

Remarks: 1. Emission Level= Antenna Factor + Cable Loss - Amp Factor + Reading.
 2. The emission levels that are 20dB below the official limit are not reported.

Test mode: BLE(GFSK)	2480MHz	Test channel:	Highest	Polarization	Vertical
----------------------	---------	---------------	---------	--------------	----------

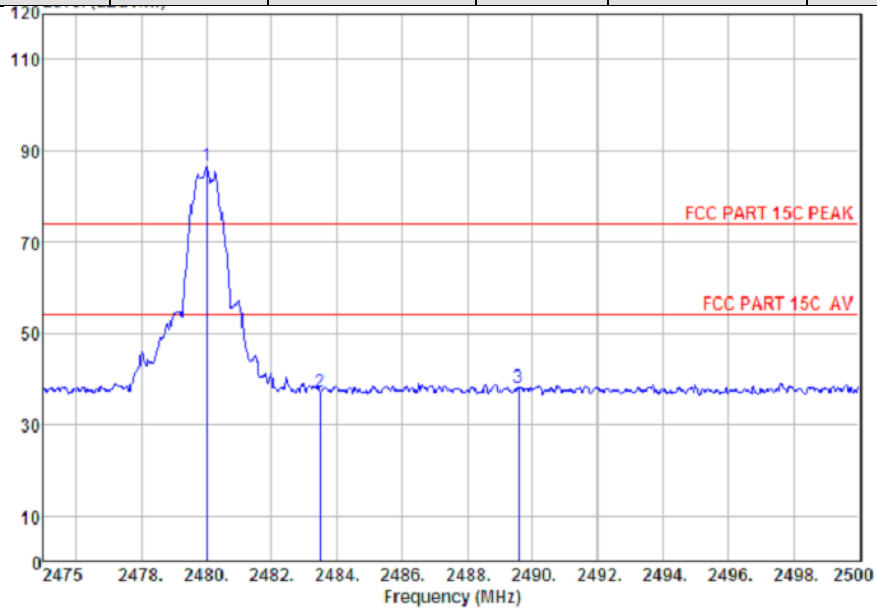

	Freq. (MHz)	Ant. Factor (dB/m)	Cable Loss (dB)	Amp Factor (dB)	Reading (dBuV)	Emission Level (dBuV/m)	Limits (dBuV/m)	Margin (dB)	Remark
1	2480.00	27.58	6.71	34.03	86.50	86.76	74.00	-12.76	Peak
2	2483.50	27.58	6.71	34.03	36.71	36.97	74.00	37.03	Peak
3	2489.58	27.58	6.73	34.03	37.83	38.11	74.00	35.89	Peak

Remarks: 1. Emission Level= Antenna Factor + Cable Loss - Amp Factor + Reading.
 2. The emission levels that are 20dB below the official limit are not reported.

Test mode: BLE(GFSK)	2480MHz	Test channel:	Highest	Polarization	Horizontal
----------------------	---------	---------------	---------	--------------	------------

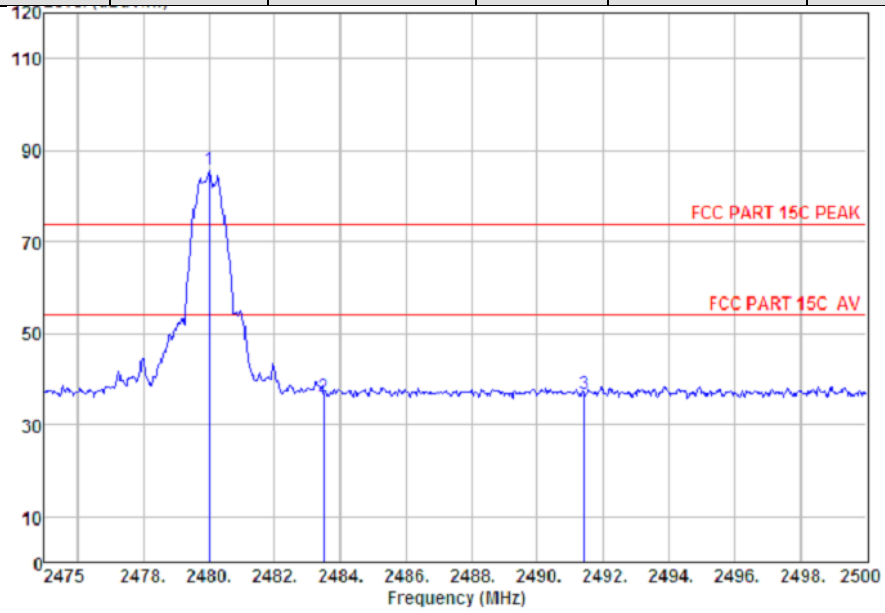

	Freq. (MHz)	Ant. Factor (dB/m)	Cable Loss (dB)	Amp Factor (dB)	Reading (dBuV)	Emission Level (dBuV/m)	Limits (dBuV/m)	Margin (dB)	Remark
1	2480.00	27.58	6.71	34.03	85.45	85.71	74.00	-11.71	Peak
2	2483.50	27.58	6.71	34.03	36.02	36.28	74.00	37.72	Peak
3	2491.43	27.58	6.73	34.03	36.60	36.88	74.00	37.12	Peak

Remarks: 1. Emission Level= Antenna Factor + Cable Loss - Amp Factor + Reading.
 2. The emission levels that are 20dB below the official limit are not reported.

6 Photographs - EUT Test Setup

6.1 Radiated Spurious Emission

9KHz~30MHz:



30MHz~1GHz:



Above 1GHz:

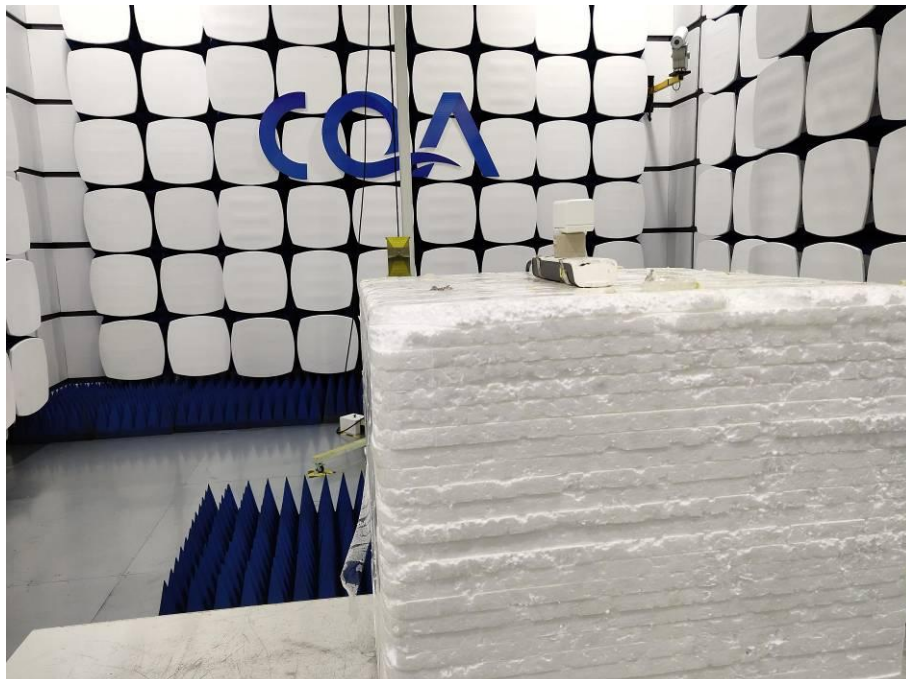

6.2 Conducted Emission



7 Photographs - EUT Constructional Details

Test model No.: MK110

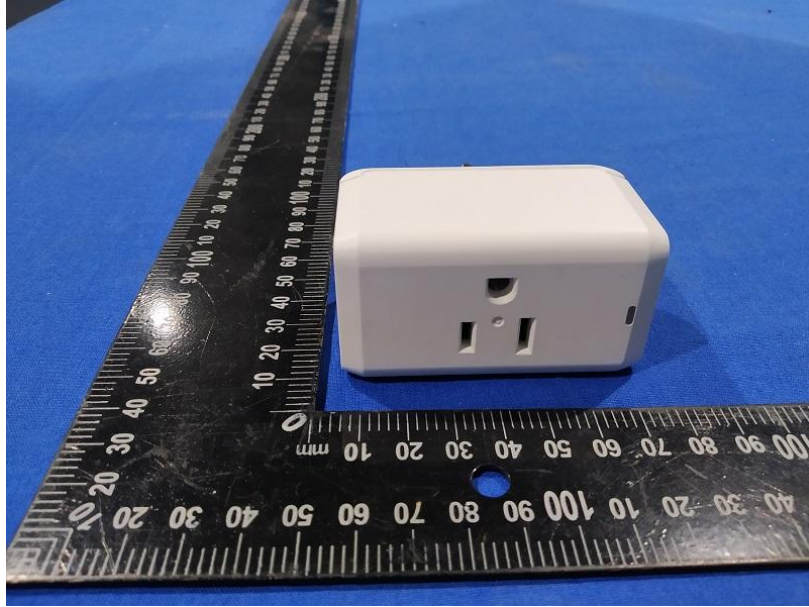

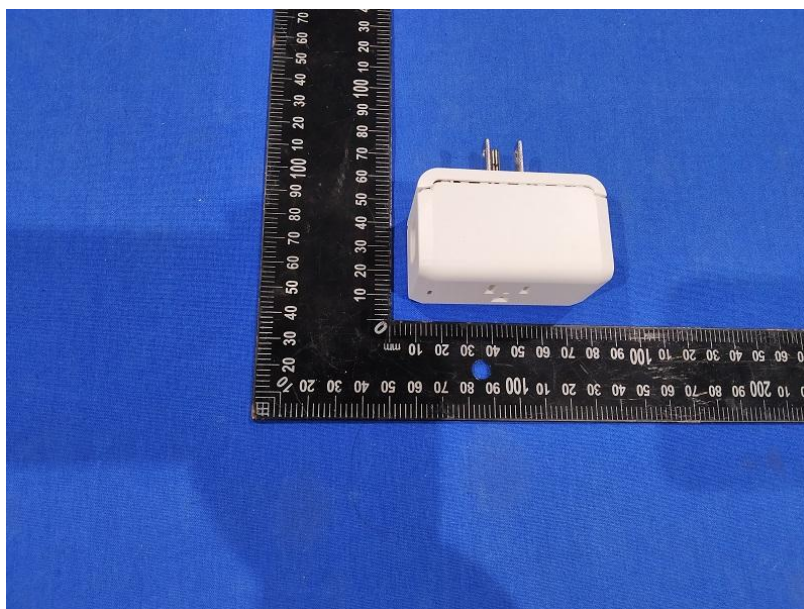
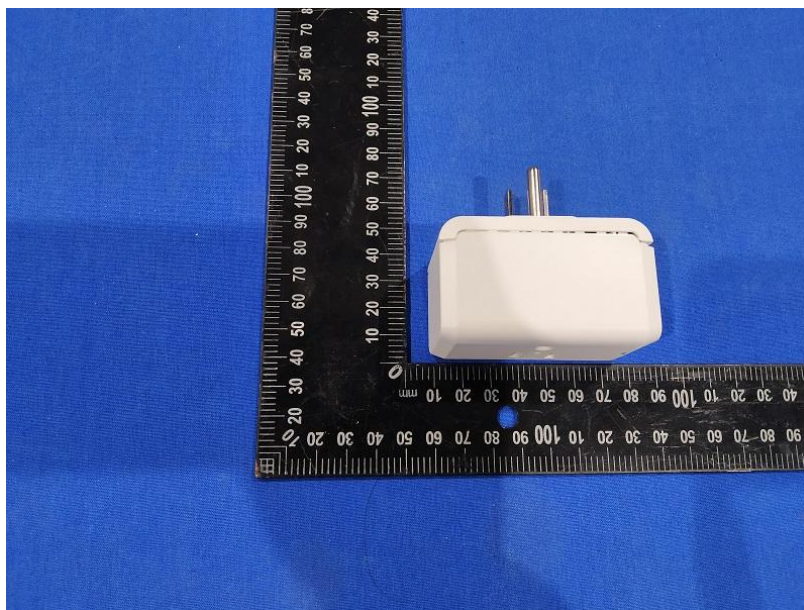

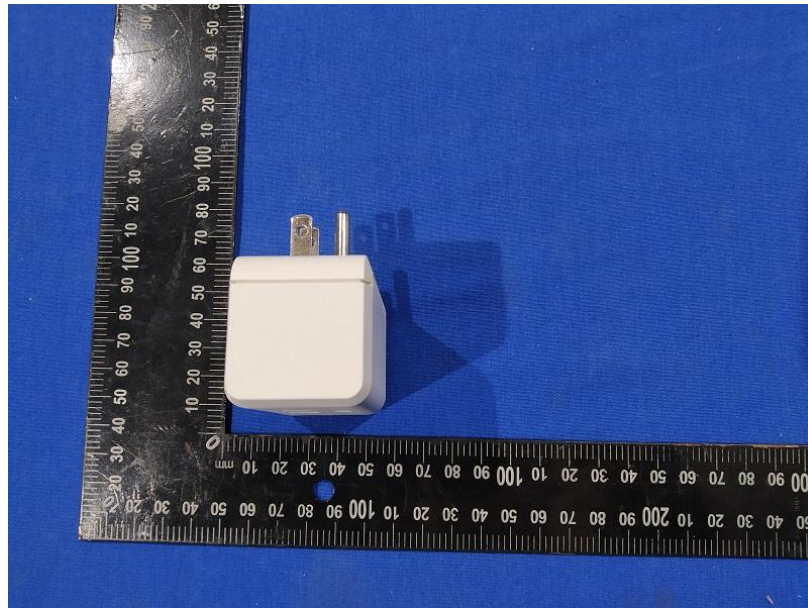

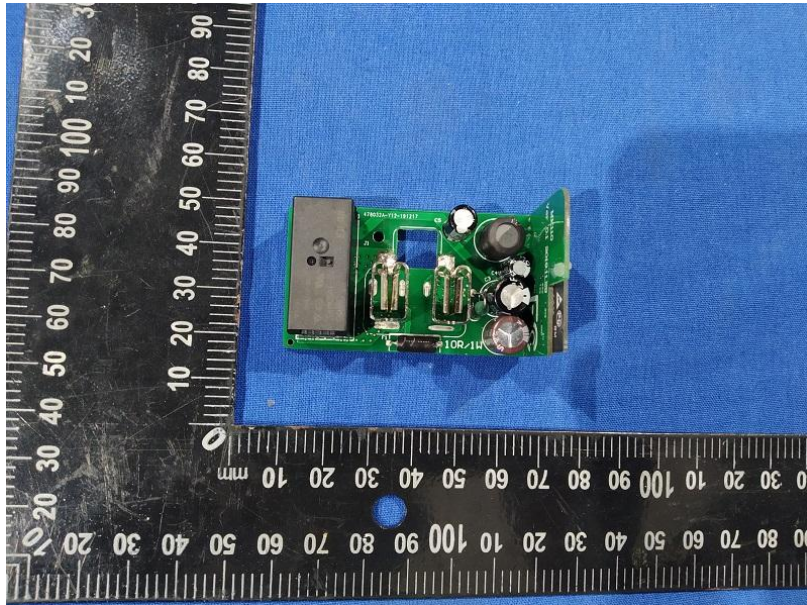
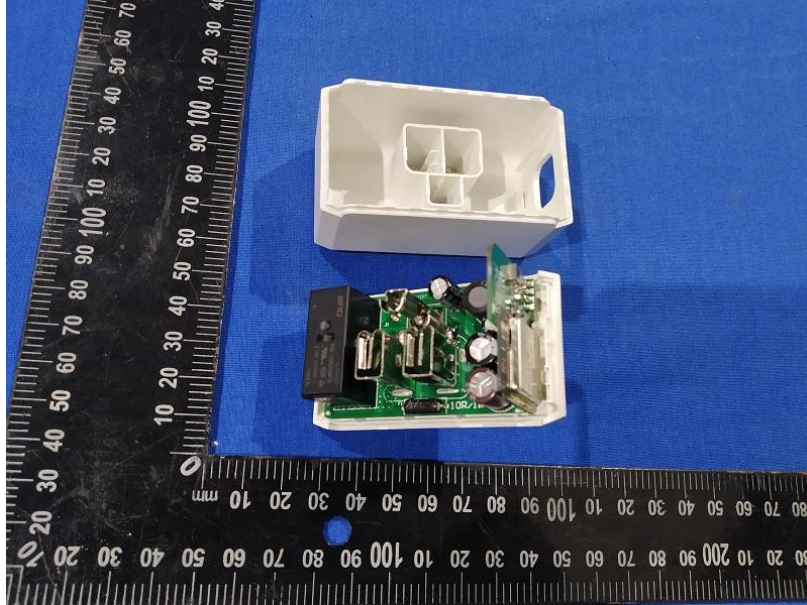

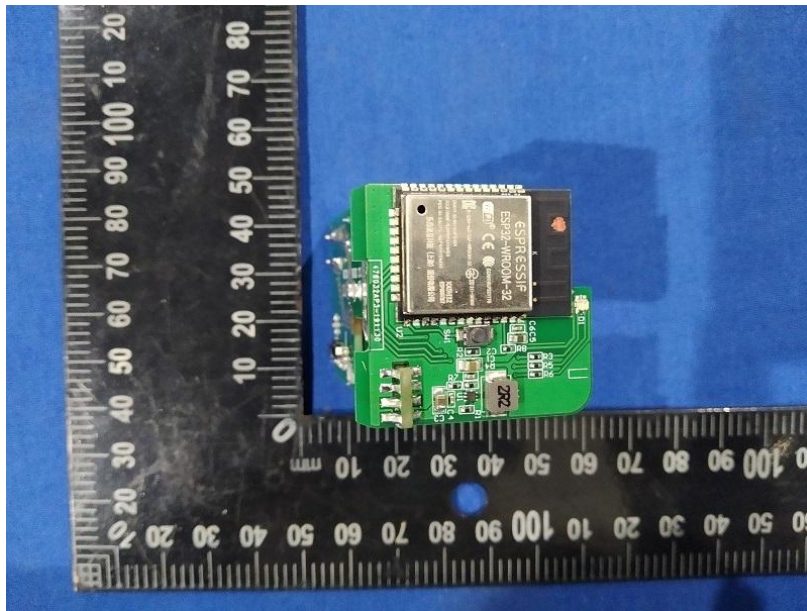
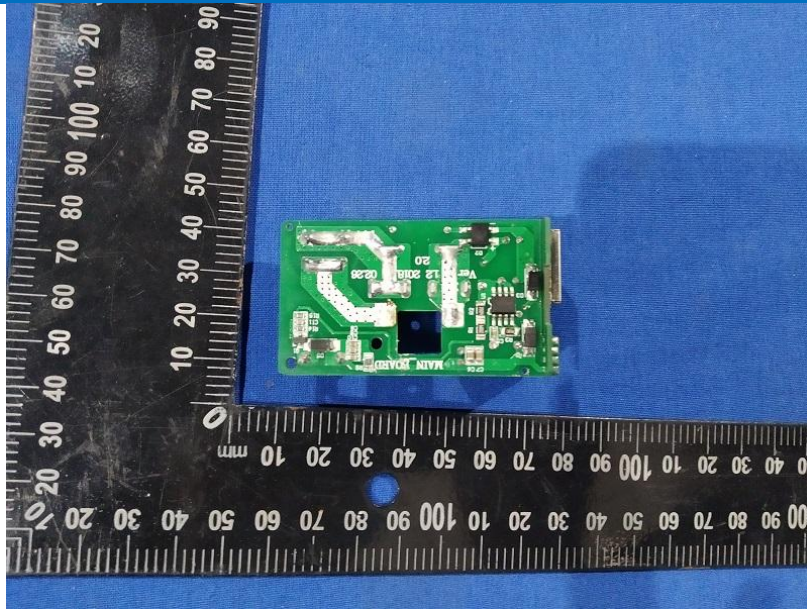

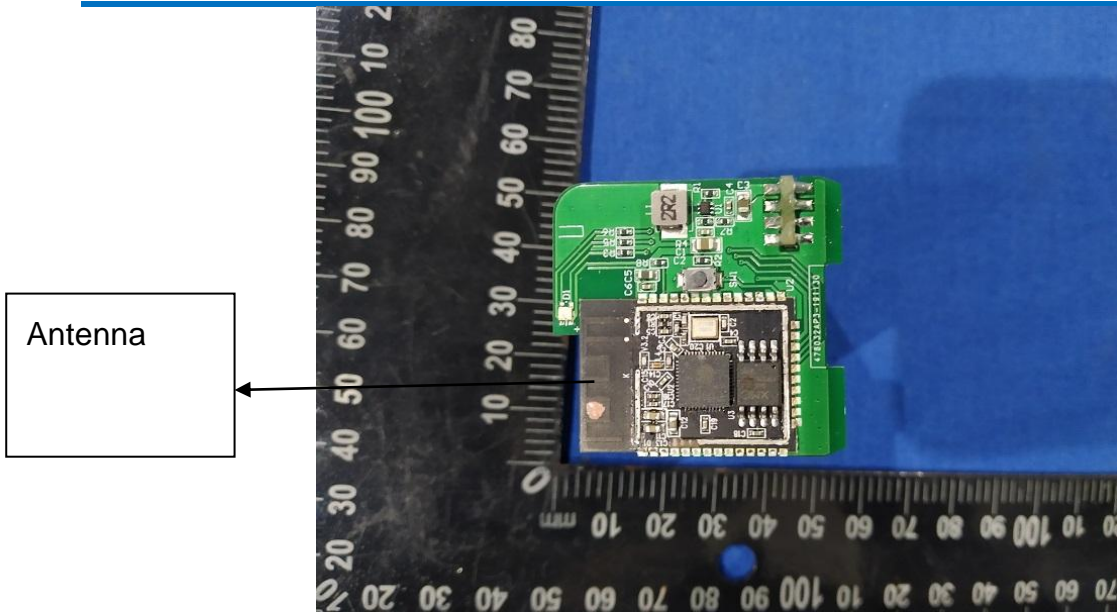

THE END