

2440 MHz

6dB Bandwidth

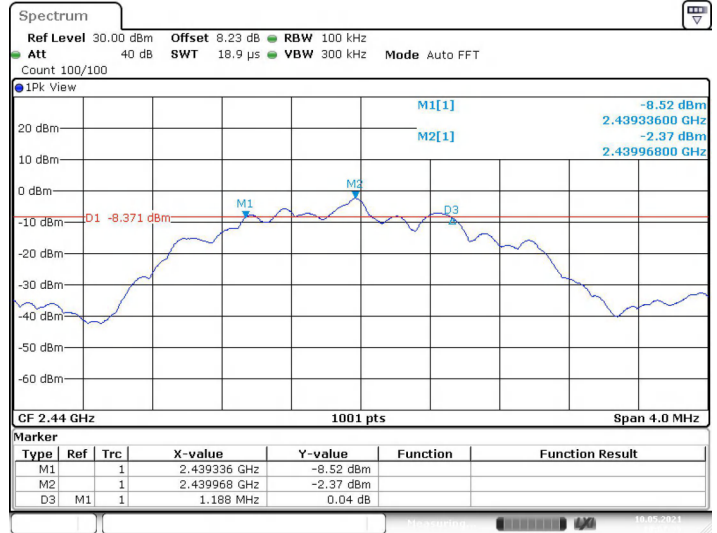

Date: 10.MAY.2021 10:07:35

99%Bandwidth

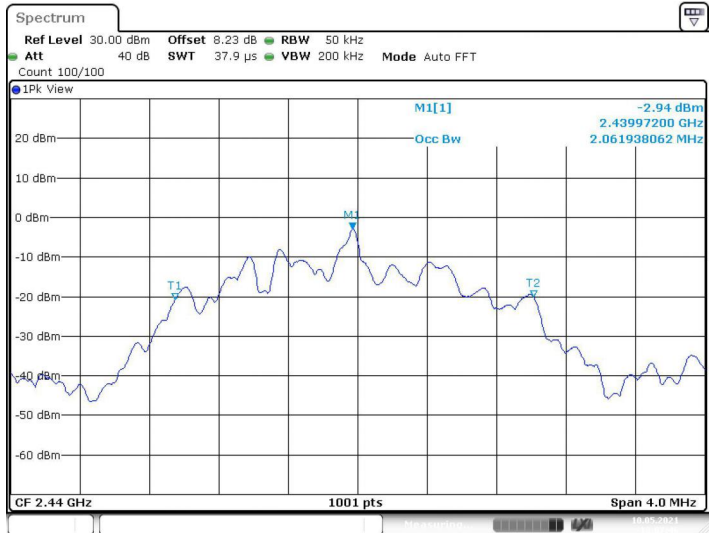

Date: 10.MAY.2021 10:07:45

2480 MHz

6dB Bandwidth

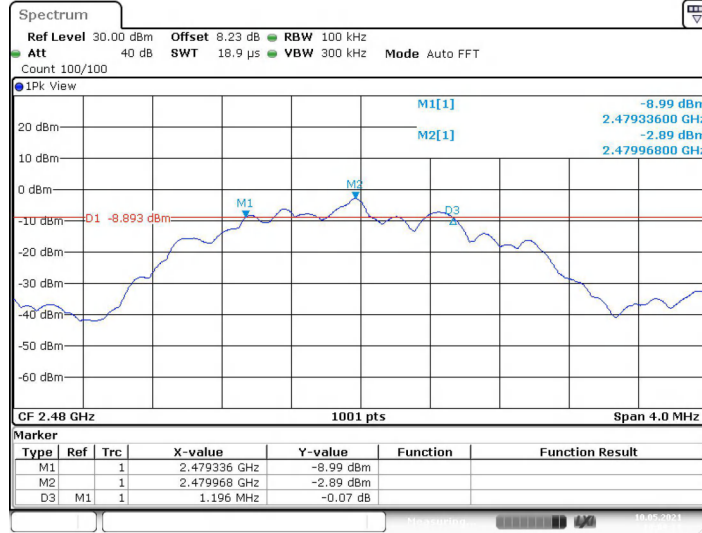

Date: 10.MAY.2021 10:09:31

99%Bandwidth

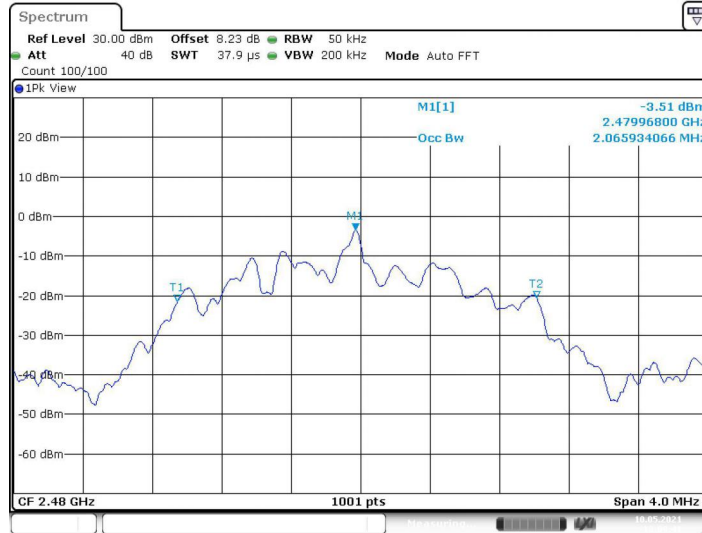

Date: 10.MAY.2021 10:09:42

3.5. Band edge and Spurious Emission (Conducted)

Limit

FCC CFR Title 47 Part 15 Subpart C Section 15.247 (d):

In any 100 kHz bandwidth outside the frequency band in which the spread spectrum intentional radiator is operating, the radio frequency power that is produced by the intentional radiator shall be at least 20 dB below that in the 100 kHz bandwidth within the band that contains the highest level of the desired power, based on either an RF conducted or a radiated measurement.

Test Configuration

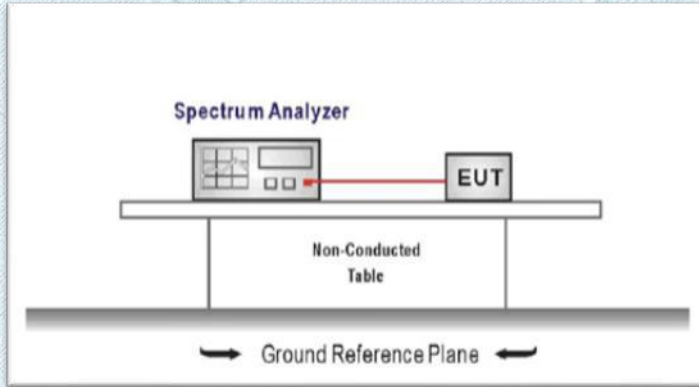

Test Procedure

1. Connect EUT RF Output port to the Spectrum Analyzer through an RF attenuator.
2. Spectrum Setting:
 RBW=100KHz
 VBW=300KHz.
 Detector function: Peak.
 Trace: Max hold.
 Sweep = Auto couple.

Allow the trace to stabilize.

Test Mode

Please refer to the clause 2.2.

Test Results

GFSK_1M

CH00-Bandedge

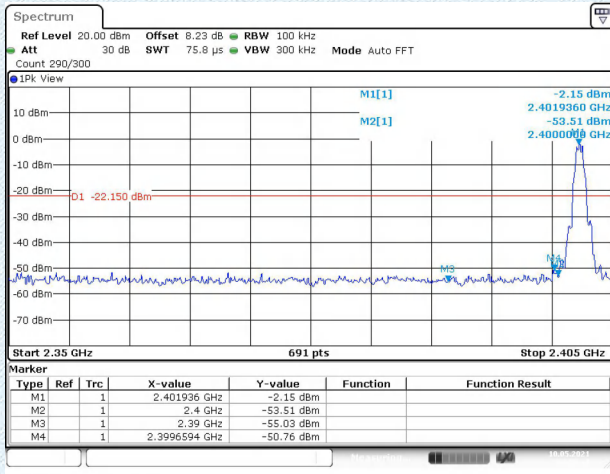

Date: 10.MAY.2021 09:56:45

CH39-Bandedge

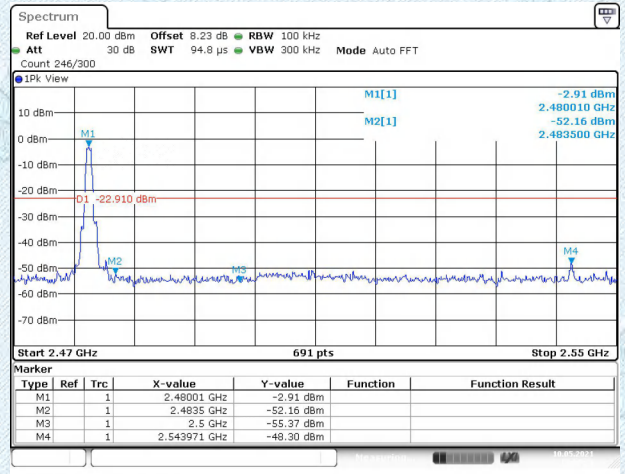

Date: 10.MAY.2021 10:02:28

GFSK_2M

CH00-Bandedge

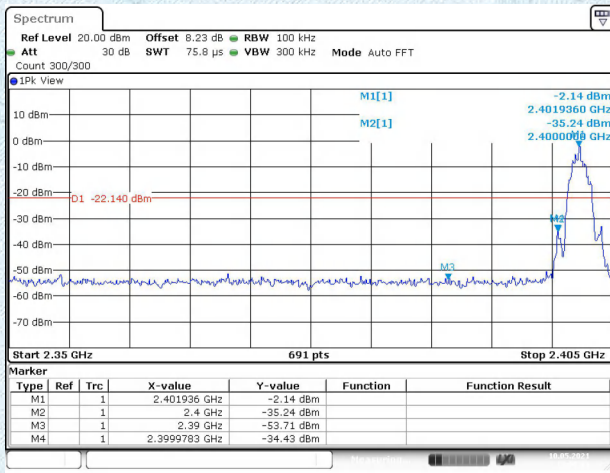

Date: 10.MAY.2021 10:05:33

CH39-Bandedge

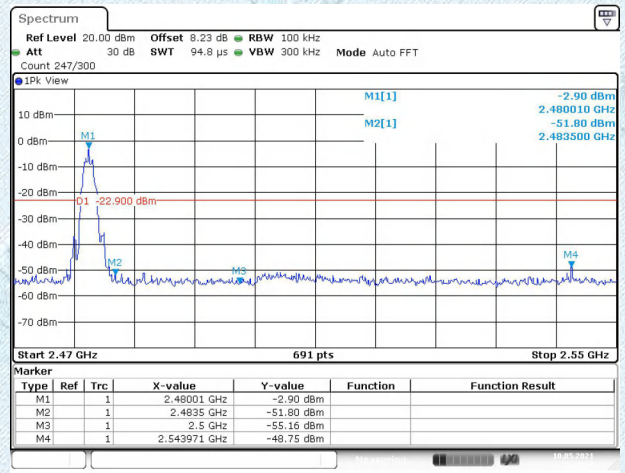

Date: 10.MAY.2021 10:10:04

GFSK_1M

CH00-SE

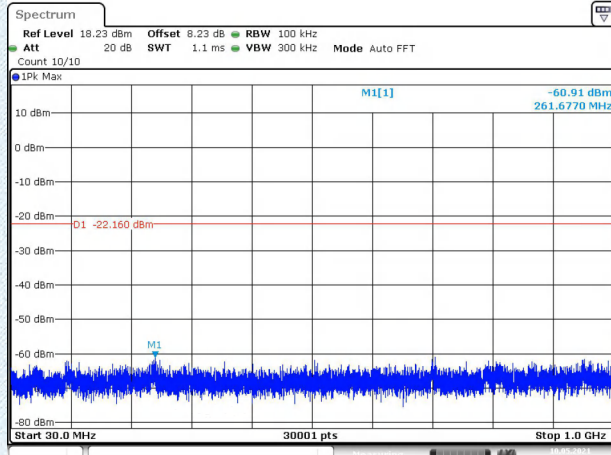

Date: 10.MAY.2021 09:57:48

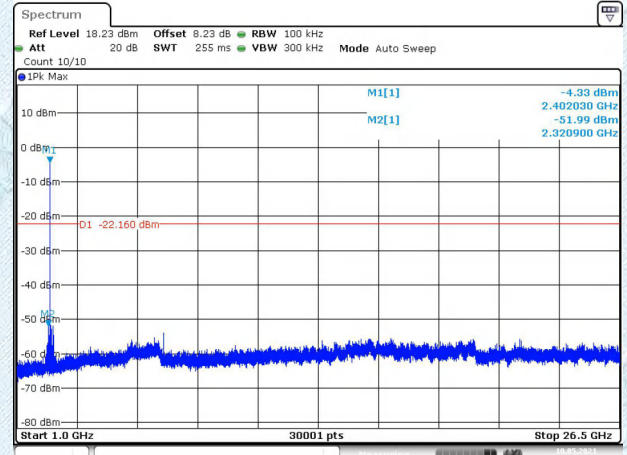

Date: 10.MAY.2021 09:58:11

CH19-SE

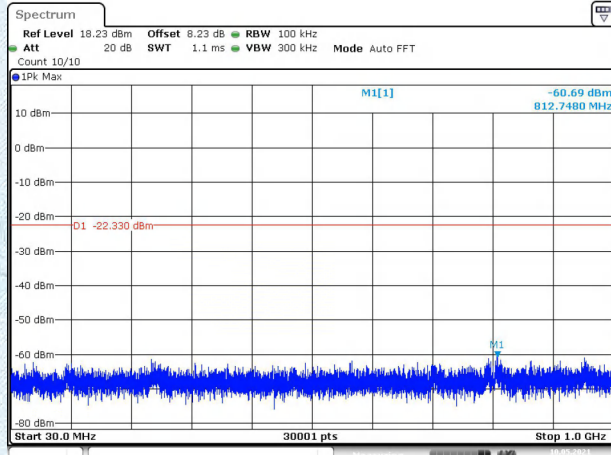

Date: 10.MAY.2021 10:00:43

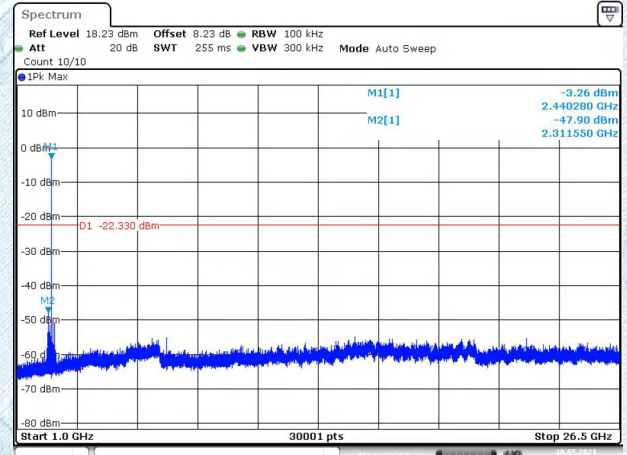

Date: 10.MAY.2021 10:01:06

CH39-SE

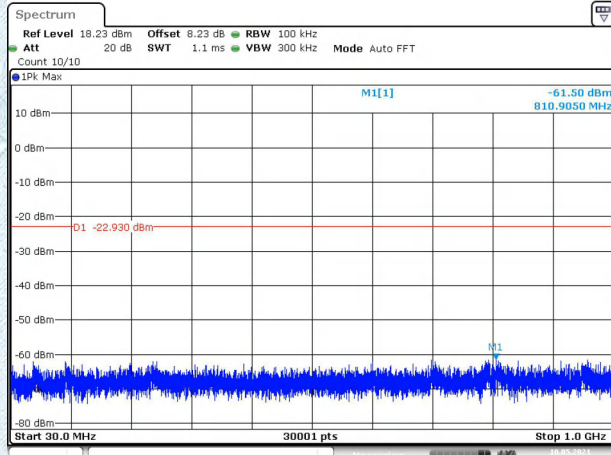

Date: 10.MAY.2021 10:03:31

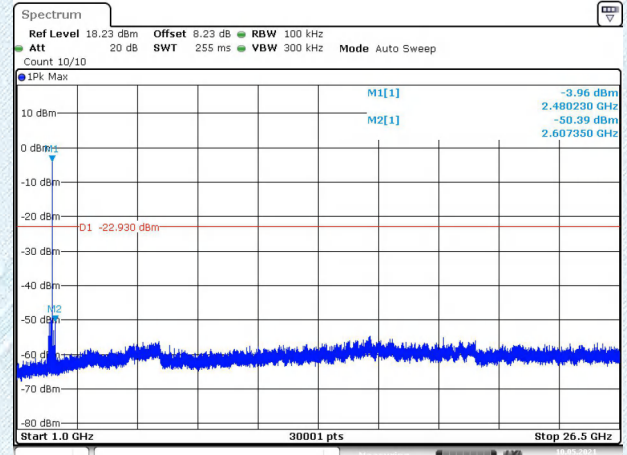

Date: 10.MAY.2021 10:03:54

GFSK_2M

CH00-SE

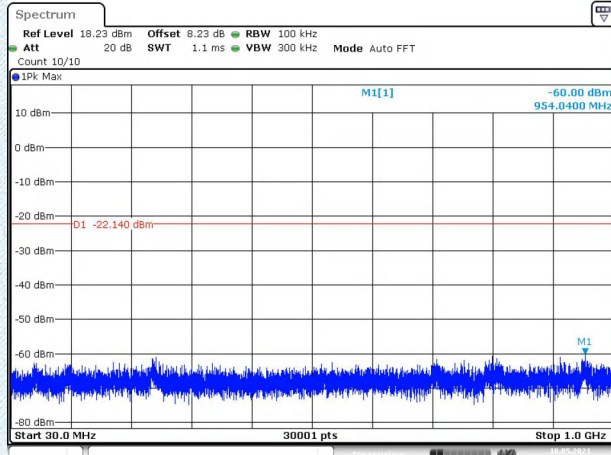

Date: 10.MAY.2021 10:06:36

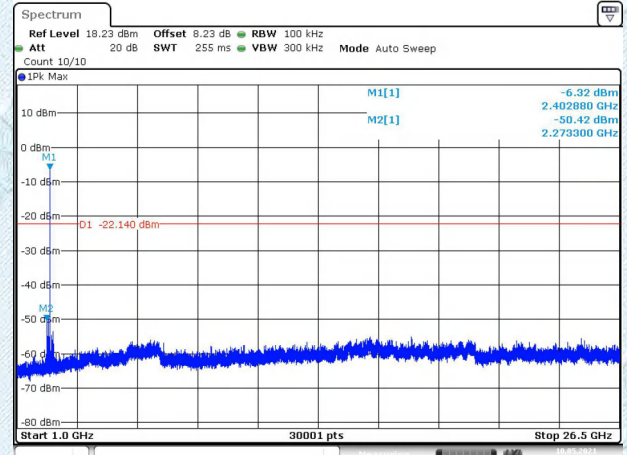

Date: 10.MAY.2021 10:06:59

CH19-SE

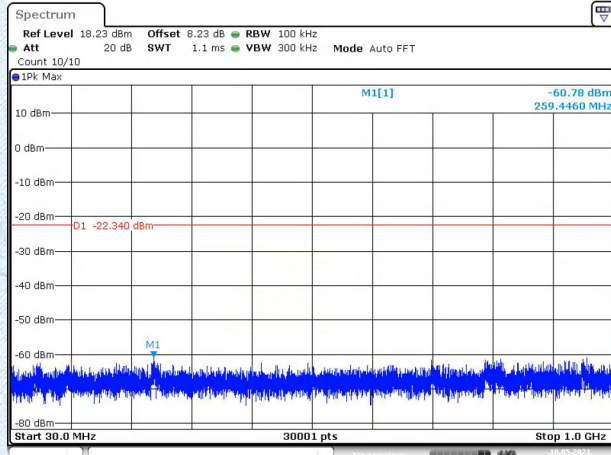

Date: 10.MAY.2021 10:08:09

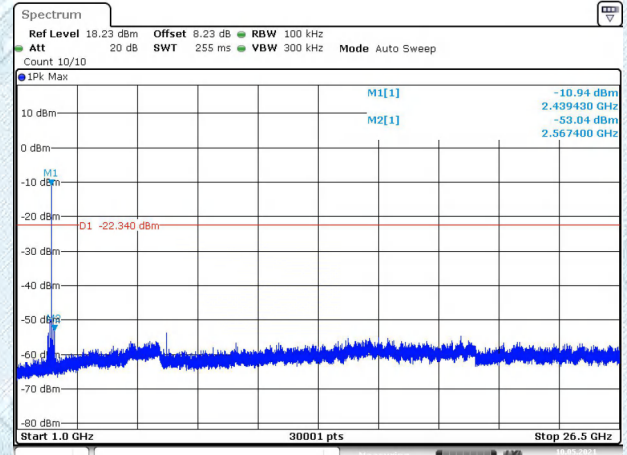

Date: 10.MAY.2021 10:08:32

CH39-SE

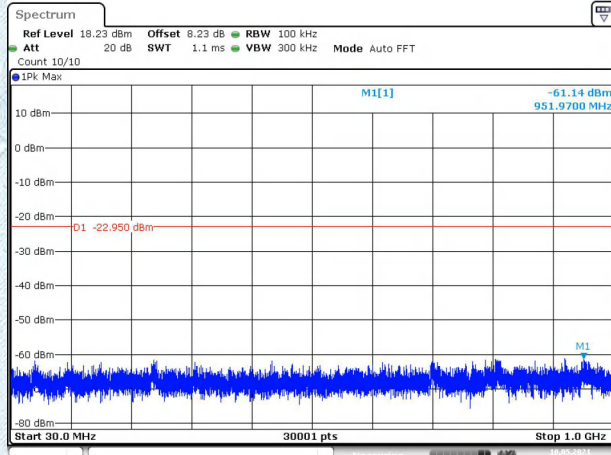

Date: 10.MAY.2021 10:11:07

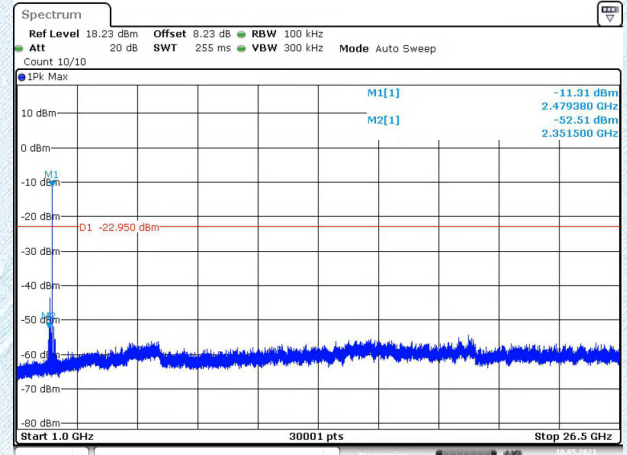

Date: 10.MAY.2021 10:11:30

3.6. Band Edge Emissions(Radiated)

Limit

Restricted Frequency Band (MHz)	(dBuV/m)(at 3m)	
	Peak	Average
2310 ~2390	74	54
2483.5 ~2500	74	54

Note: All restriction bands have been tested, only the worst case is reported.

Test Configuration

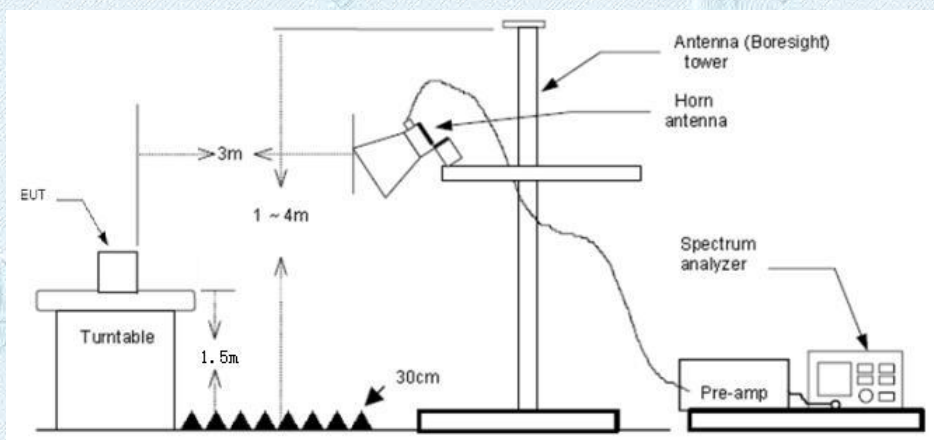

Test Procedure

1. The EUT was setup and tested according to ANSI C63.10:2013 requirements.
2. The EUT is placed on a turn table which is 1.5 meter above ground. The turn table is rotated 360 degrees to determine the position of the maximum emission level.
3. The EUT was positioned such that the distance from antenna to the EUT was 3 meters.
4. The antenna is scanned from 1 meter to 4 meters to find out the maximum emission level. This is repeated for both horizontal and vertical polarization of the antenna. In order to find the maximum emission, all of the interface cables were manipulated according to ANSI C63.10:2013 on radiated measurement.
5. The receiver set as follow:
 RBW=1MHz, VBW=3MHz PEAK detector for Peak value.
 RBW=1MHz, VBW=10Hz with PEAK Detector for Average Value.

Test Mode

Please refer to the clause 2.2.

Test Results

Note:

- (1)Measurement = Reading level + Correct Factor
- (2)Correct Factor=Antenna Factor + Cable Loss -Preamplifier Factor
- (3)All modulation modes were tested, and only the worst data of GFSK_2M was recorded in the report.

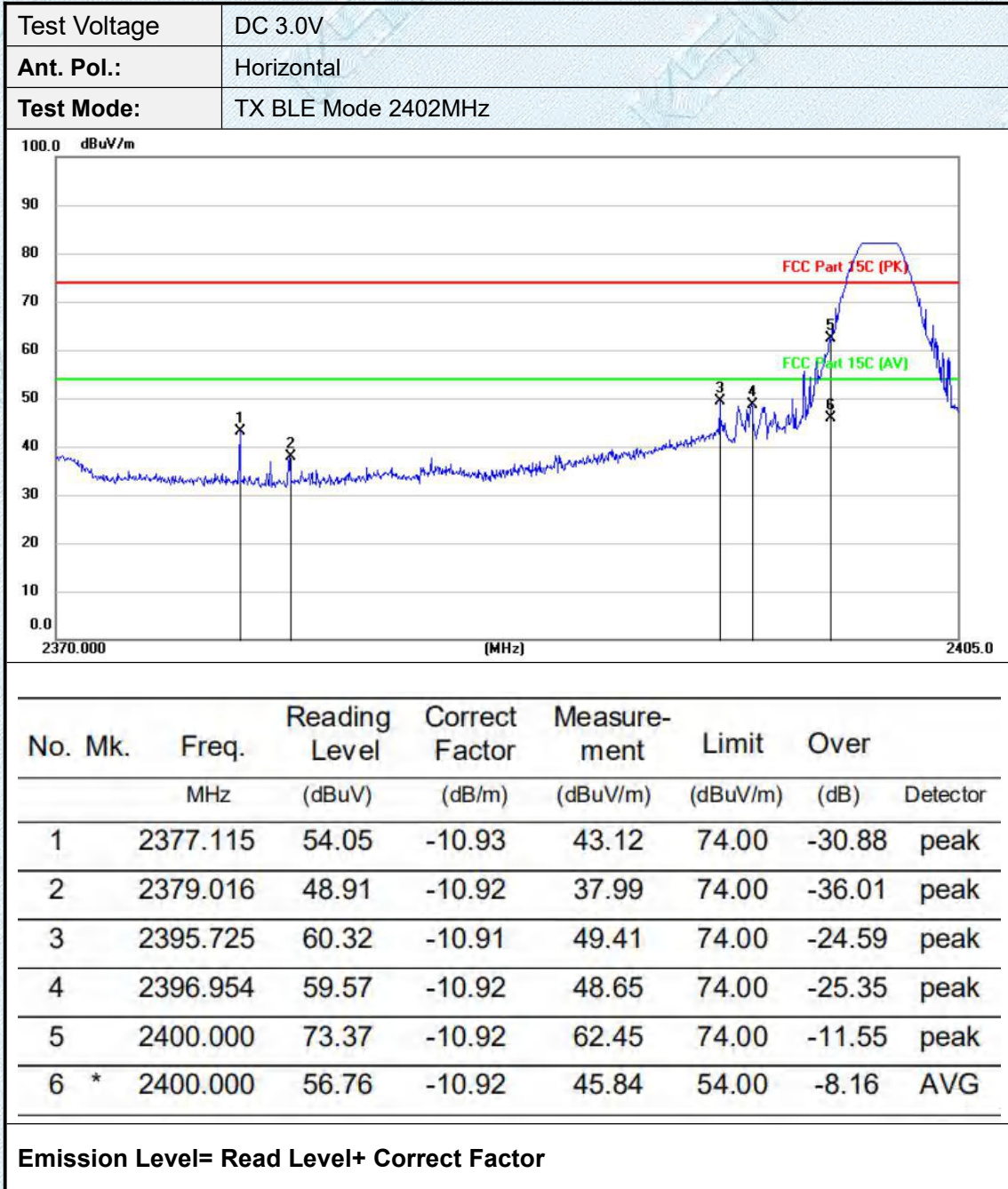

Test Voltage	DC 3.0V
Ant. Pol.	Vertical
Test Mode:	TX BLE Mode 2402MHz

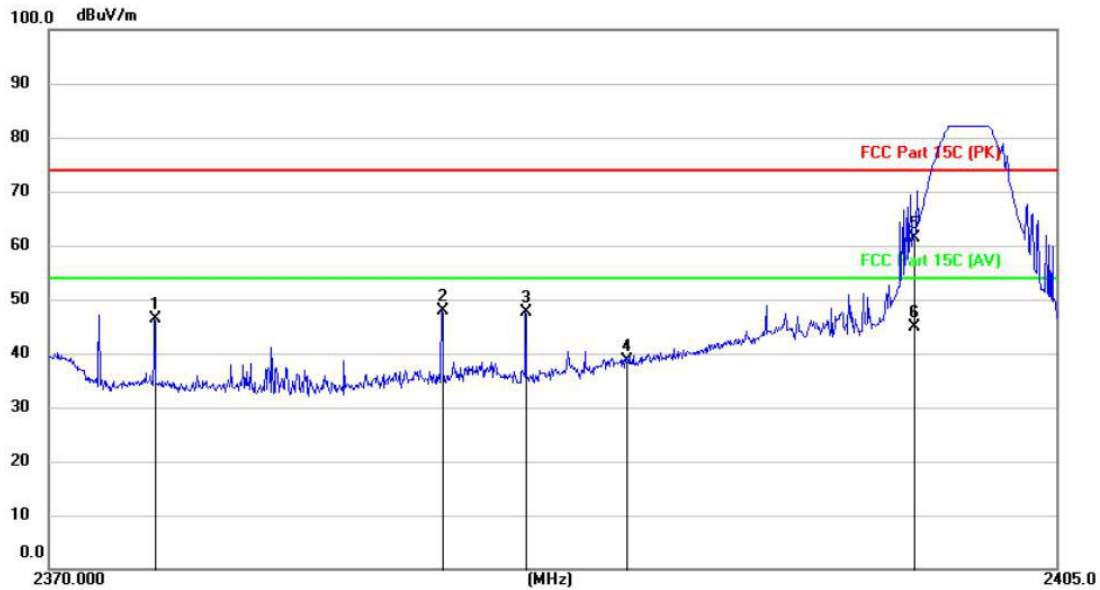

No.	Mk.	Freq. MHz	Reading Level (dBuV)	Correct Factor (dB/m)	Measure- ment (dBuV/m)	Limit (dBuV/m)	Over (dB)	Detector
1		2373.654	57.32	-10.93	46.39	74.00	-27.61	peak
2		2383.597	58.88	-10.92	47.96	74.00	-26.04	peak
3		2386.513	58.61	-10.92	47.69	74.00	-26.31	peak
4		2390.000	49.48	-10.92	38.56	74.00	-35.44	peak
5		2400.000	72.20	-10.92	61.28	74.00	-12.72	peak
6	*	2400.000	55.74	-10.92	44.82	54.00	-9.18	AVG

Emission Level= Read Level+ Correct Factor

Test Voltage	DC 3.0V
Ant. Pol.	Horizontal
Test Mode:	TX BLE Mode 2480 MHz

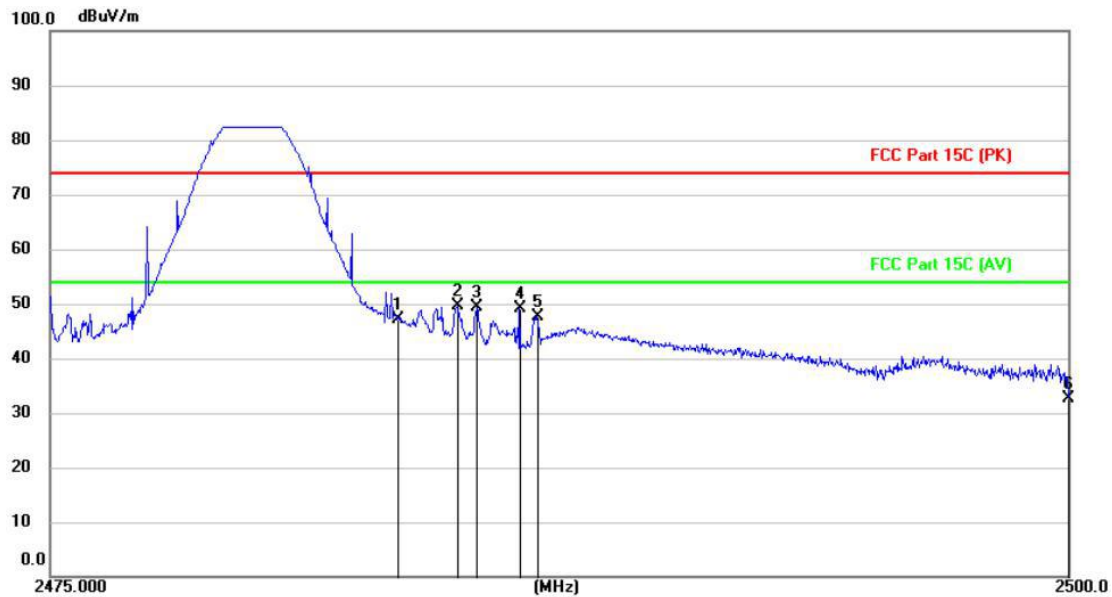

No.	Mk.	Freq. MHz	Reading Level (dBuV)	Correct Factor (dB/m)	Measure- ment (dBuV/m)	Limit (dBuV/m)	Over (dB)	Detector
1		2483.500	57.91	-10.88	47.03	74.00	-26.97	peak
2	*	2484.970	60.47	-10.88	49.59	74.00	-24.41	peak
3		2485.444	60.32	-10.88	49.44	74.00	-24.56	peak
4		2486.494	60.07	-10.88	49.19	74.00	-24.81	peak
5		2486.919	58.57	-10.88	47.69	74.00	-26.31	peak
6		2500.000	43.41	-10.88	32.53	74.00	-41.47	peak

Emission Level= Read Level+ Correct Factor

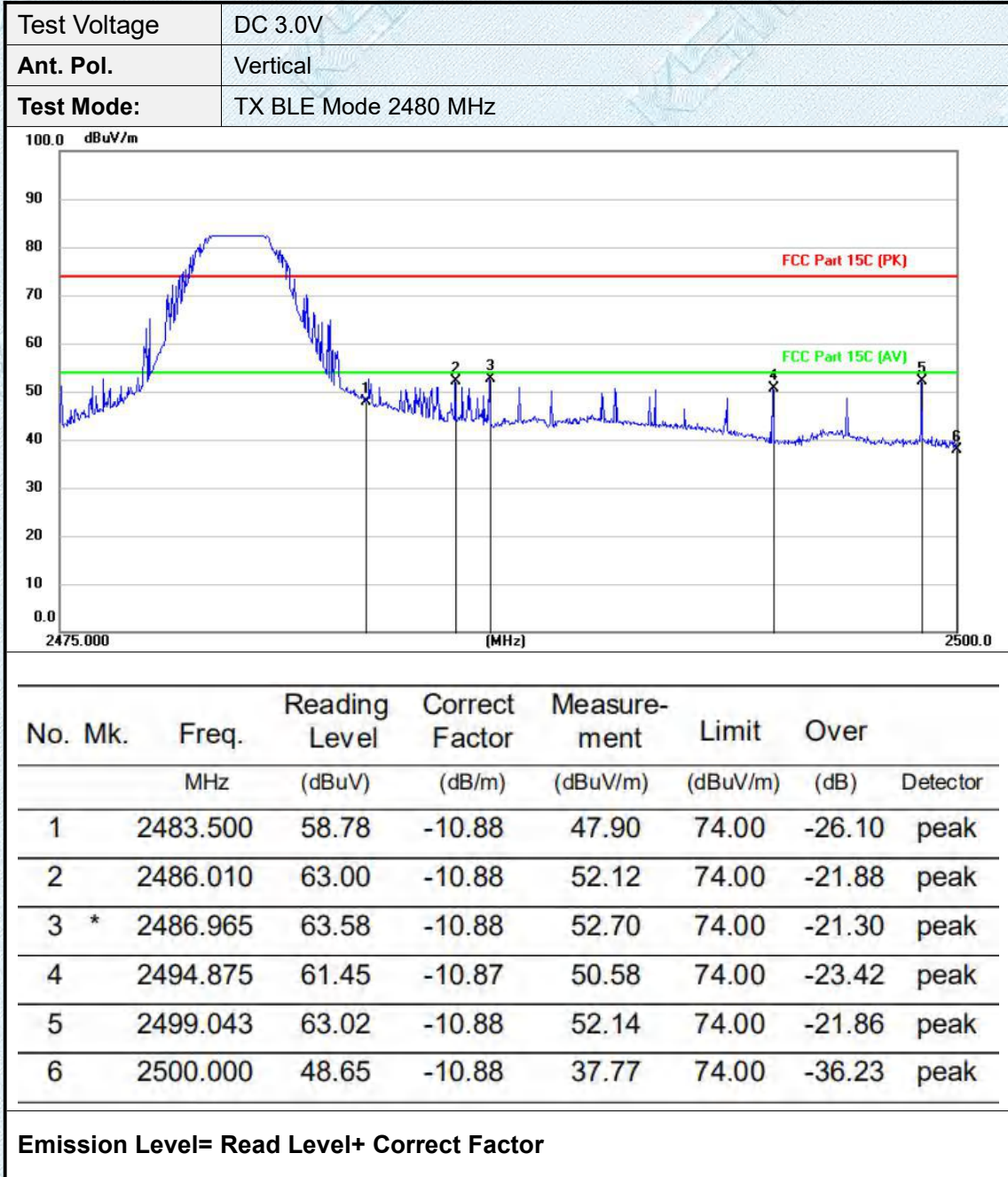

3.7. Spurious Emission (Radiated)

Limit

Radiated Emission Limits (9 kHz~1000 MHz)

Frequency (MHz)	Field Strength (microvolt/meter)	Measurement Distance (meters)
0.009~0.490	2400/F(KHz)	300
0.490~1.705	24000/F(KHz)	30
1.705~30.0	30	30
30~88	100	3
88~216	150	3
216~960	200	3
Above 960	500	3

Radiated Emission Limit (Above 1000MHz)

Frequency (MHz)	Distance Meters(at 3m)	
	Peak	Average
Above 1000	74	54

Note:

- (1) The tighter limit applies at the band edges.
- (2) Emission Level (dBuV/m)=20log Emission Level (uV/m).

Test Configuration

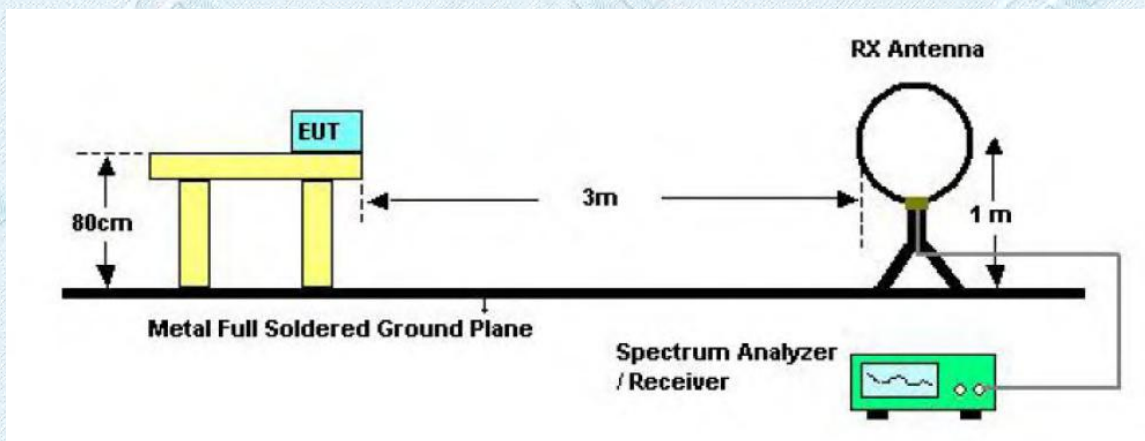

Below 30MHz Test Setup

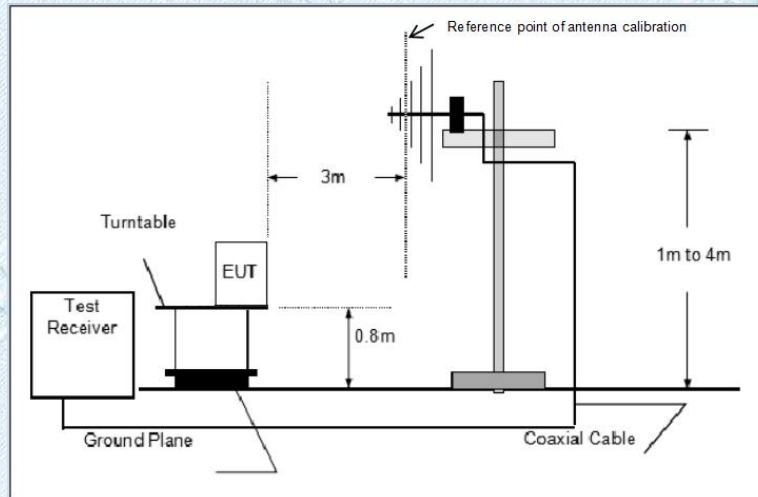

Below 1000MHz Test Setup

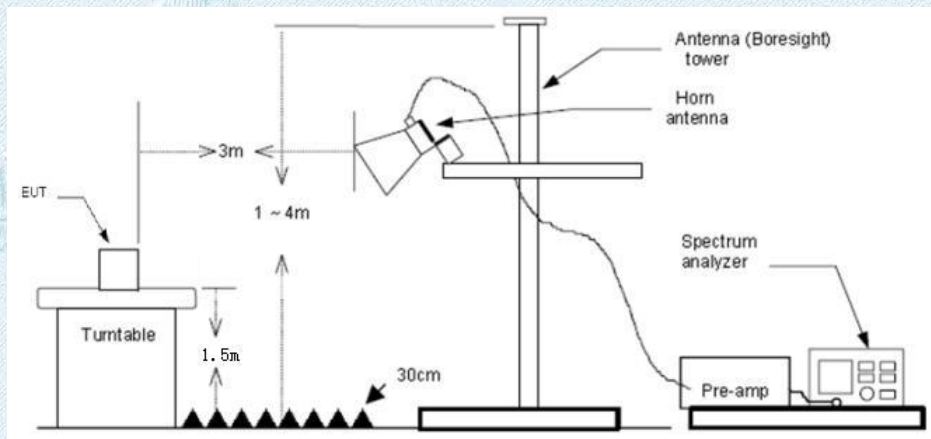

Above 1GHz Test Setup

Test Procedure

1. The EUT was setup and tested according to ANSI C63.10:2013
2. The EUT is placed on a turn table which is 0.8 meter above ground for below 1 GHz, and 1.5 m for above 1 GHz. The turn table is rotated 360 degrees to determine the position of the maximum emission level.
3. The EUT was set 3 meters from the receiving antenna, which was mounted on the top of a variable height antenna tower.
4. For each suspected emission, the EUT was arranged to its worst case and then tune the Antenna tower (from 1 m to 4 m) and turntable (from 0 degree to 360 degrees) to find the maximum reading. A pre-amp and a high pass filter are used for the test in order to get better signal level to comply with the guidelines.
5. Set to the maximum power setting and enable the EUT transmit continuously.
6. Use the following spectrum analyzer settings
 - (1) Span shall wide enough to fully capture the emission being measured;
 - (2) Below 1 GHz:
 RBW=120 kHz, VBW=300 kHz, Sweep=auto, Detector function=peak, Trace=max hold;
 If the emission level of the EUT measured by the peak detector is 3 dB lower than the applicable limit, the peak emission level will be reported. Otherwise, the emission measurement will be repeated using the quasi-peak detector and reported.
 - (3) From 1 GHz to 10th harmonic:
 RBW=1MHz, VBW=3MHz Peak detector for Peak value.
 RBW=1MHz, VBW=10Hz Peak detector for Peak value.

Test Mode

Please refer to the clause 2.2.

Test Result**9 KHz~30 MHz and 18GHz~25GHz**

From 9 KHz~30 MHz and 18GHz~25GHz: Conclusion: PASS

Note:

- 1) Measurement = Reading level + Correct Factor
Correct Factor=Antenna Factor + Cable Loss -Preamplifier Factor
- 2) The peak level is lower than average limit(54 dBuV/m), this data is the too weak instrument of signal is unable to test.
- 3) The emission levels of other frequencies are very lower than the limit and not show in test report.
- 4) The amplitude of spurious emissions which are attenuated by more than 20dB below the permissible value has no need to be reported.
- 5) Pre-scan CH00, CH19 and CH49 modulation, and found the GFSK_2M_CH00 which it is worse case for 30MHz-1GHz , So only show the test data for worse case.

BELOW 30MHZ

No emission found between lowest internal used/generated frequencies to 30MHz.

30MHz-1GHz

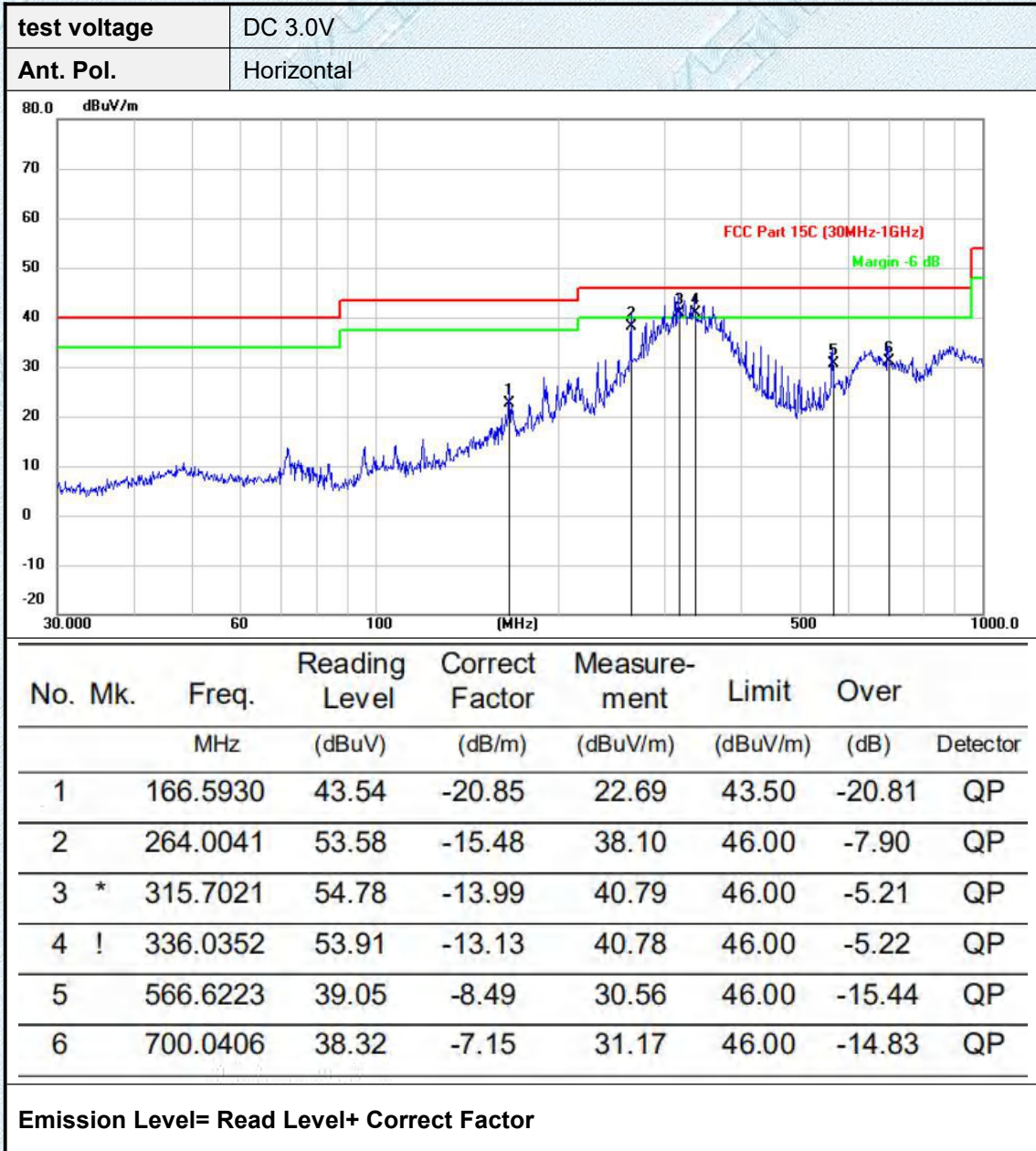

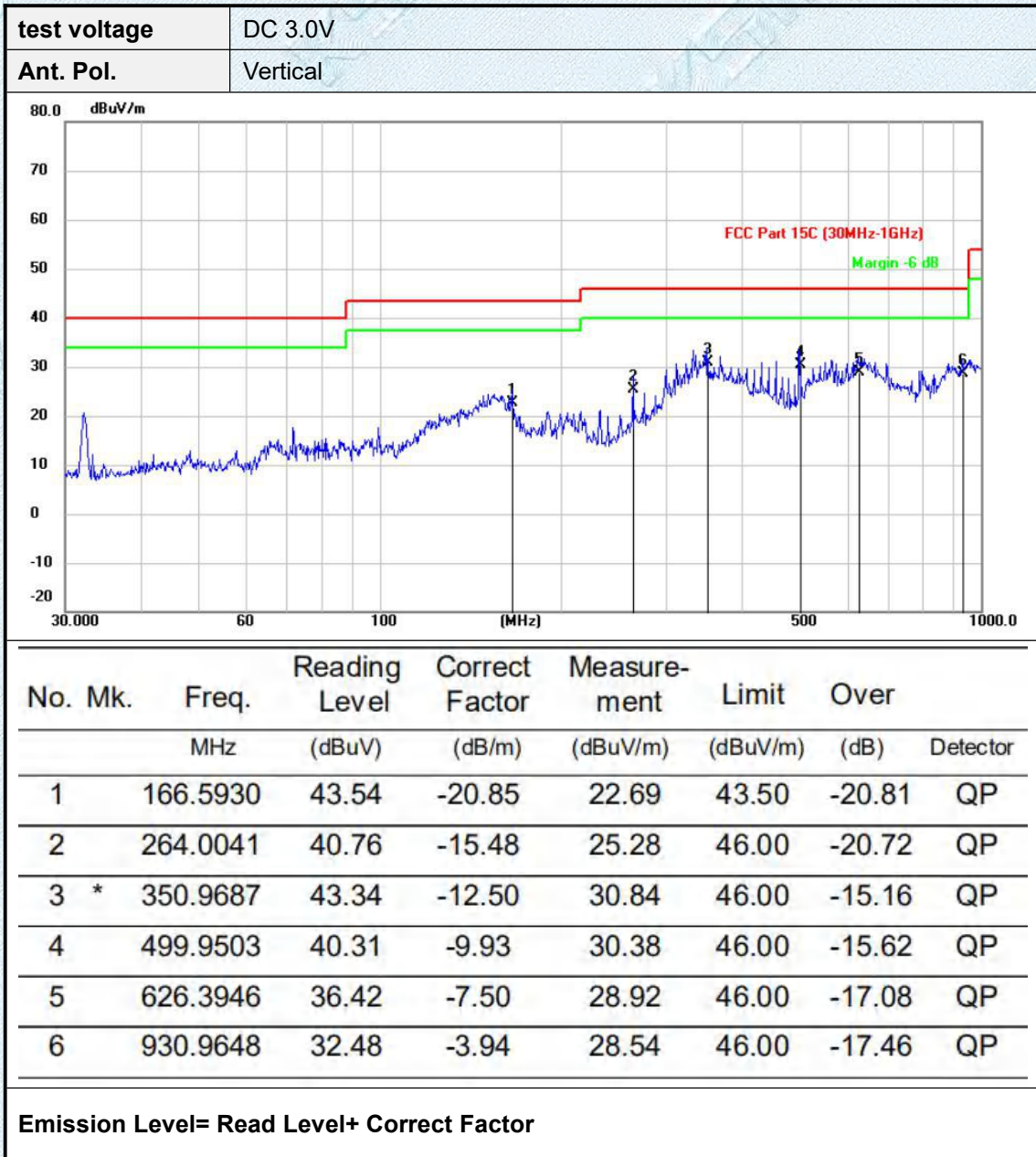

Adobe 1GHz

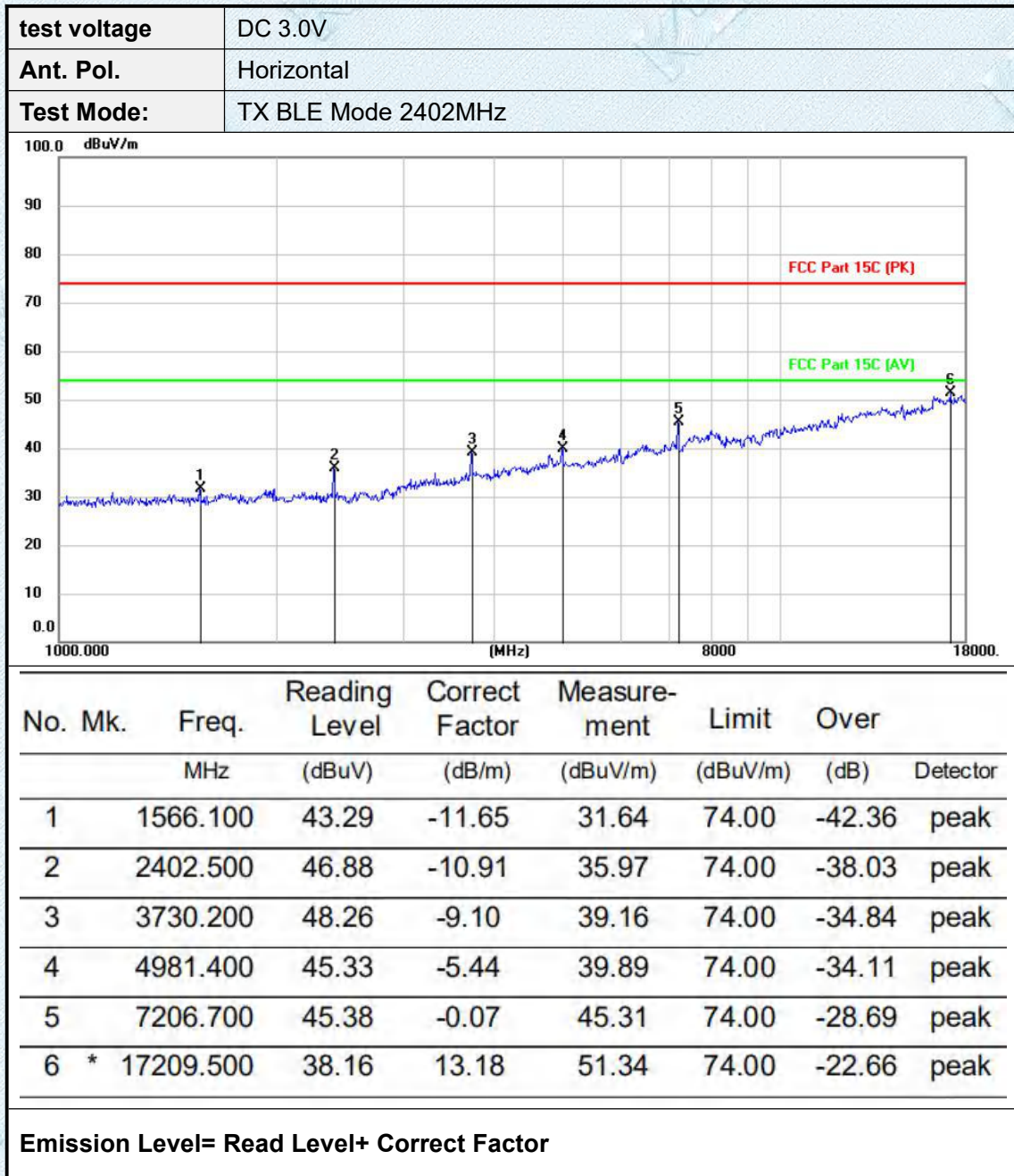

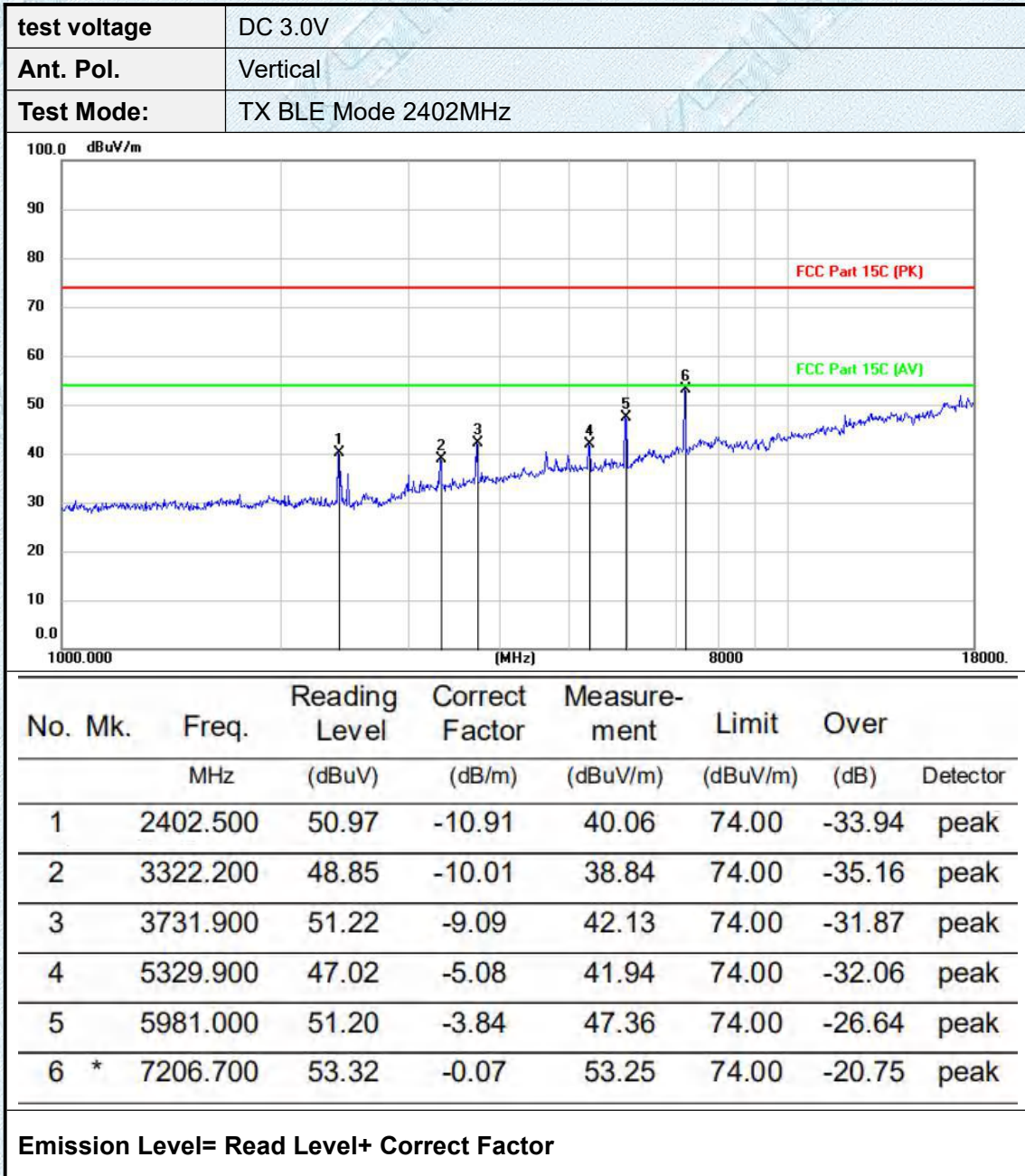

test voltage	DC 3.0V
Ant. Pol.	Horizontal
Test Mode:	TX BLE Mode 2440MHz

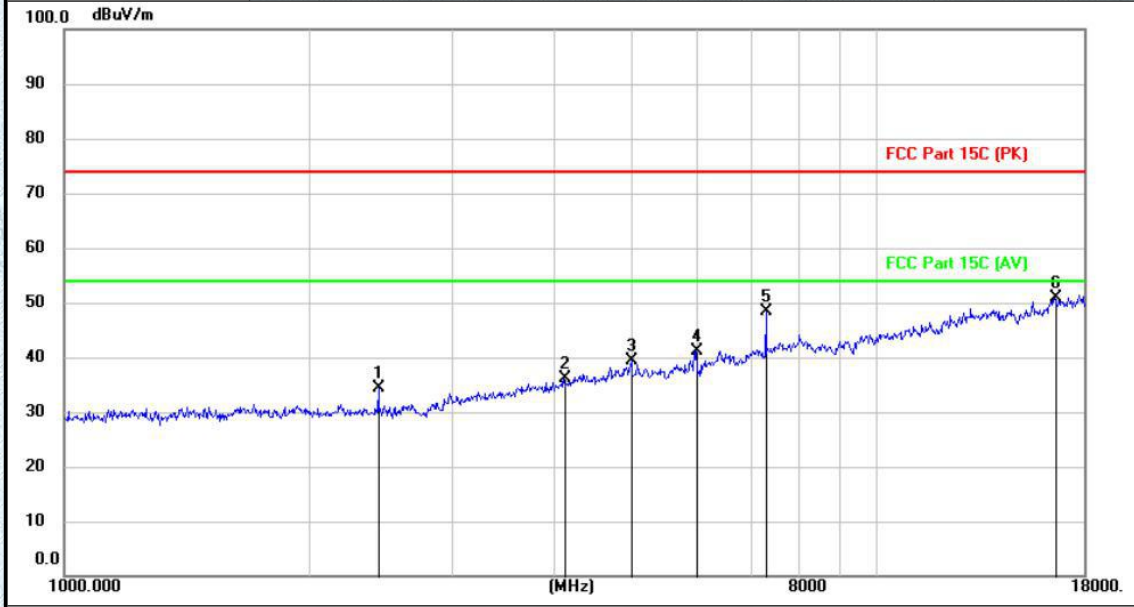

No. Mk.	Freq. MHz	Reading Level (dBuV)	Correct Factor (dB/m)	Measure- ment (dBuV/m)	Limit (dBuV/m)	Over (dB)	Detector
1	2439.900	45.35	-10.90	34.45	74.00	-39.55	peak
2	4122.900	44.21	-8.02	36.19	74.00	-37.81	peak
3	4989.900	44.91	-5.42	39.49	74.00	-34.51	peak
4	5994.600	44.98	-3.81	41.17	74.00	-32.83	peak
5	7320.600	48.03	0.27	48.30	74.00	-25.70	peak
6 *	16582.200	37.31	13.68	50.99	74.00	-23.01	peak

Emission Level= Read Level+ Correct Factor

test voltage	DC 3.0V
Ant. Pol.	Vertical
Test Mode:	TX BLE Mode 2440MHz

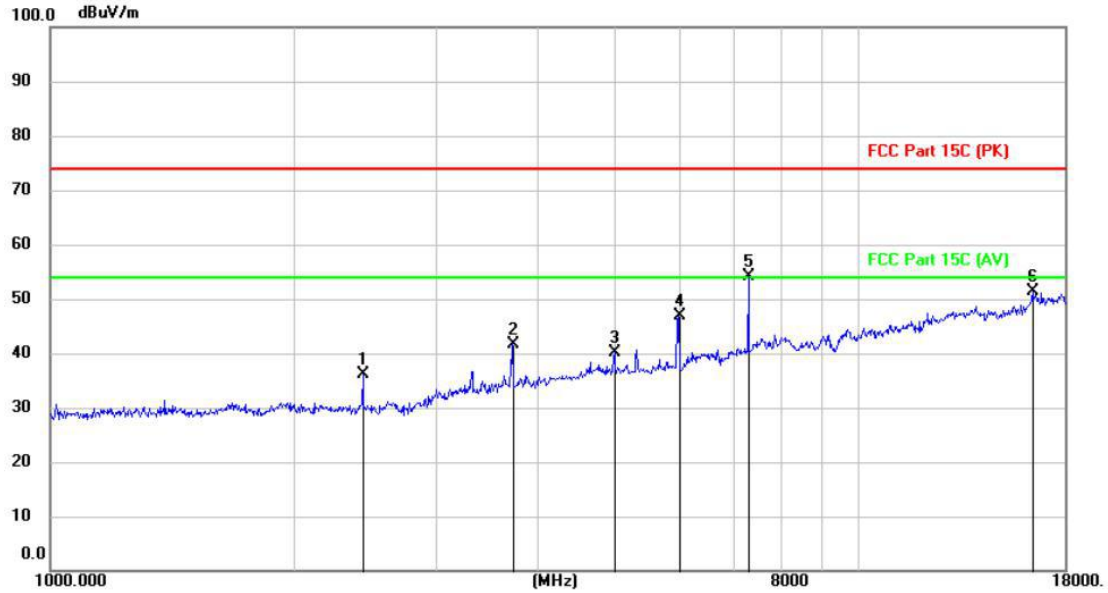

No.	Mk.	Freq. MHz	Reading Level (dBuV)	Correct Factor (dB/m)	Measure- ment (dBuV/m)	Limit (dBuV/m)	Over (dB)	Detector
1		2439.900	47.00	-10.90	36.10	74.00	-37.90	peak
2		3728.500	50.87	-9.12	41.75	74.00	-32.25	peak
3		4988.200	45.57	-5.43	40.14	74.00	-33.86	peak
4		5984.400	50.64	-3.84	46.80	74.00	-27.20	peak
5	*	7320.600	53.79	0.27	54.06	74.00	-19.94	peak
6		16456.400	37.75	13.71	51.46	74.00	-22.54	peak

Emission Level= Read Level+ Correct Factor

test voltage	DC 3.0V
Ant. Pol.	Horizontal
Test Mode:	TX BLE Mode 2480MHz

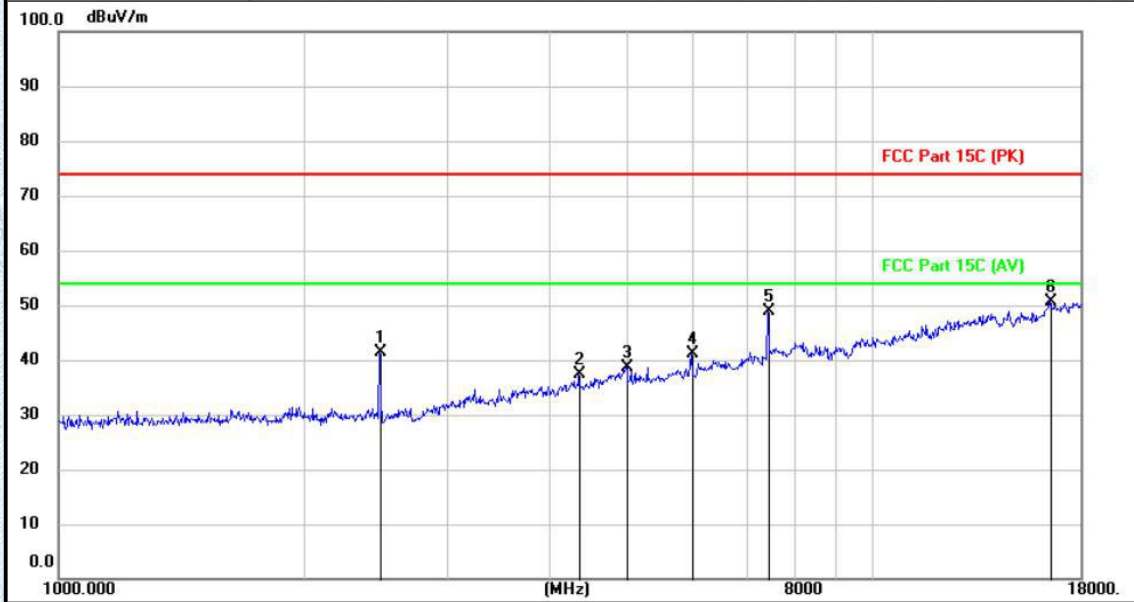

No.	Mk.	Freq. MHz	Reading Level (dBuV)	Correct Factor (dB/m)	Measure- ment (dBuV/m)	Limit (dBuV/m)	Over (dB)	Detector
1		2480.700	52.38	-10.89	41.49	74.00	-32.51	peak
2		4360.900	44.72	-7.22	37.50	74.00	-36.50	peak
3		4988.200	44.16	-5.43	38.73	74.00	-35.27	peak
4		5987.800	44.92	-3.83	41.09	74.00	-32.91	peak
5		7437.900	48.33	0.63	48.96	74.00	-25.04	peak
6	*	16522.700	36.90	13.77	50.67	74.00	-23.33	peak

Emission Level= Read Level+ Correct Factor

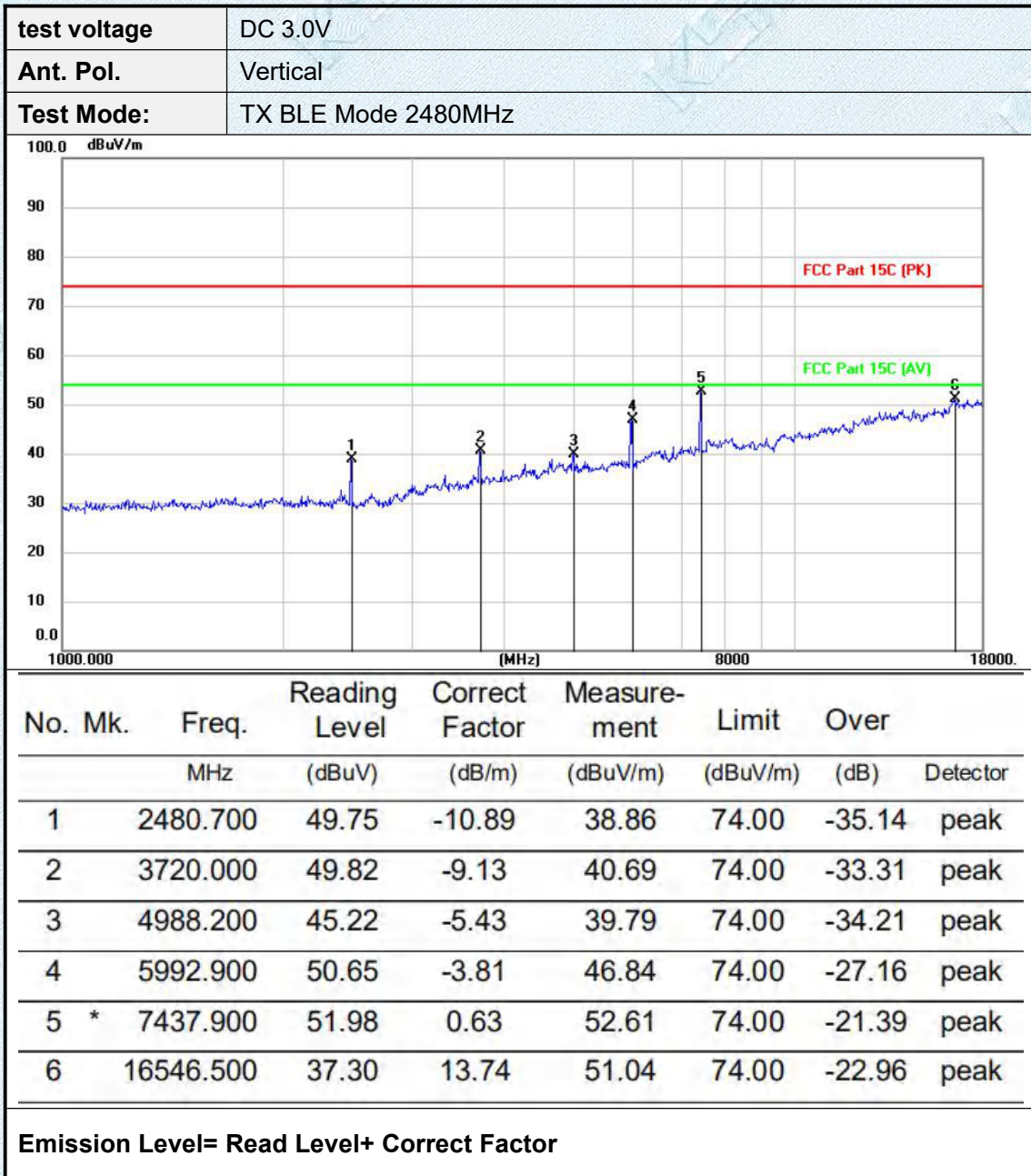

Note: All modulation modes were tested, and only the worst data of GFSK_2M was recorded in the report.

3.8. Conducted Emission

Limit

Conducted Emission Test Limit

Frequency	Maximum RF Line Voltage (dB μ V)	
	Quasi-peak Level	Average Level
150kHz~500kHz	66 ~ 56 *	56 ~ 46 *
500kHz~5MHz	56	46
5MHz~30MHz	60	50

Notes:

- (1) *Decreasing linearly with logarithm of the frequency.
- (2) The lower limit shall apply at the transition frequencies.
- (3) The limit decrease in line with the logarithm of the frequency in the range of 0.15 to 0.50MHz.

Test Configuration

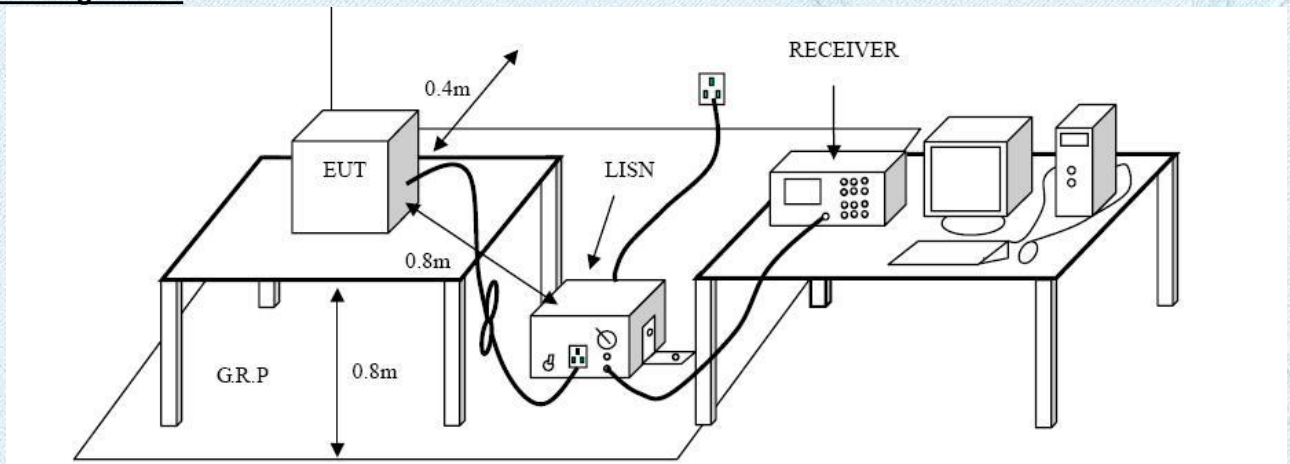

Test Procedure

1. The EUT was setup according to ANSI C63.10:2013 requirements.
2. The EUT was placed on a platform of nominal size, 1 m by 1.5 m, raised 80 cm above the conducting ground plane. The vertical conducting plane was located 40 cm to the rear of the EUT. All other surfaces of EUT were at least 80 cm from any other grounded conducting surface.
3. The EUT and simulators are connected to the main power through a line impedances stabilization network (LISN). The LISN provides a 50ohm /50uH coupling impedance for the measuring equipment. The peripheral devices are also connected to the main power through a LISN. (Please refer to the block diagram of the test setup and photographs)
4. Each current-carrying conductor of the EUT power cord, except the ground (safety) conductor, was individually connected through a LISN to the input power source.
5. The excess length of the power cord between the EUT and the LISN receptacle were folded back and forth at the center of the lead to form a bundle not exceeding 40 cm in length.
6. Conducted Emissions were investigated over the frequency range from 0.15MHz to 30MHz using a receiver bandwidth of 9 kHz.
7. During the above scans, the emissions were maximized by cable manipulation.

Test Mode:

Please refer to the clause 2.2.

Test Results

N/A

The product is dry battery power supply

4.EUT TEST PHOTOS

Radiated Measurement (Below 1GHz)

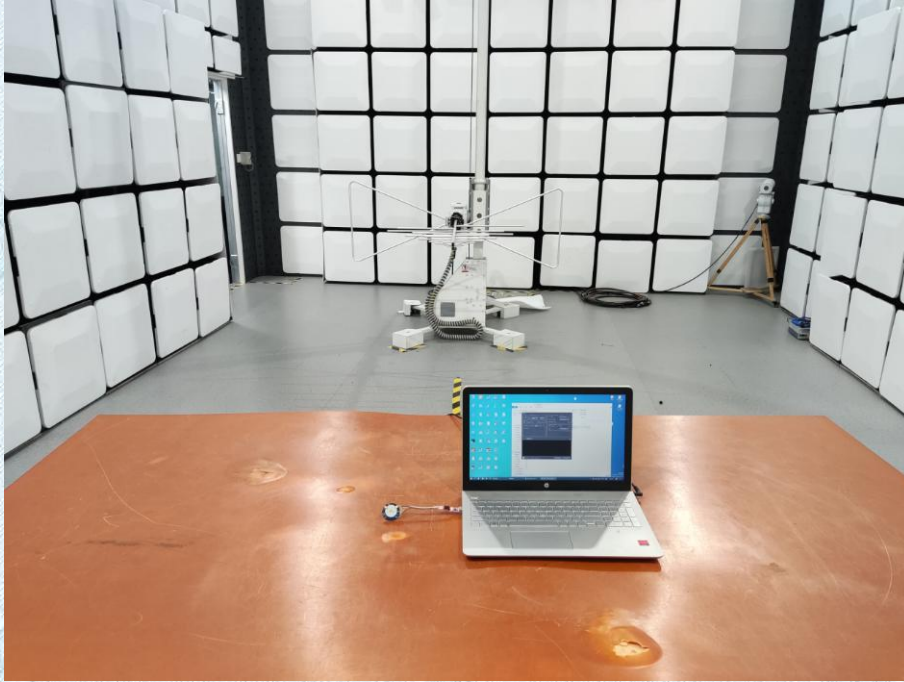

Radiated Measurement (Above 1GHz)

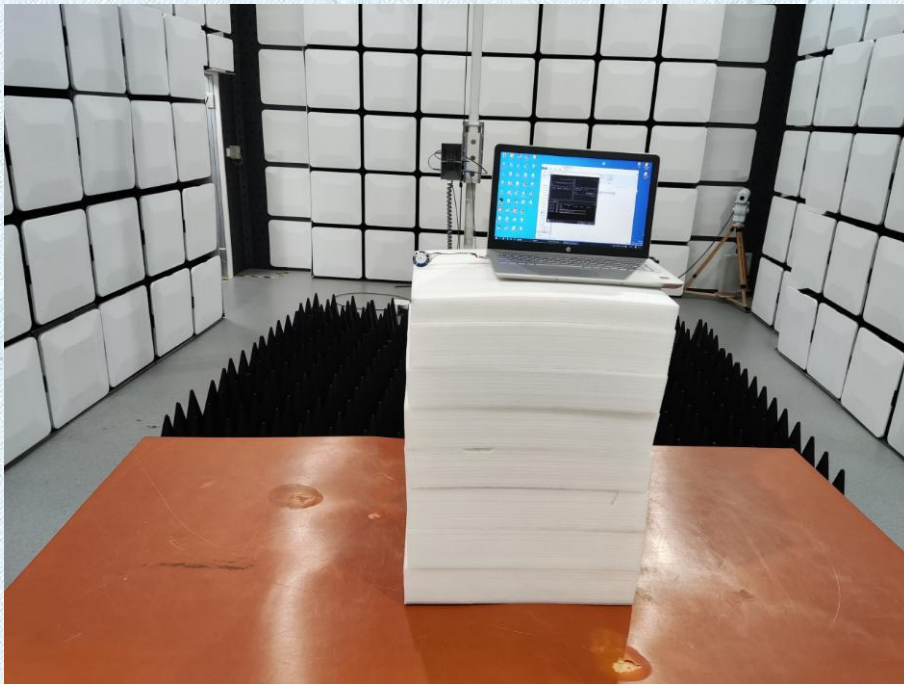

RF Conducted



5.PHOTOGRAPHS OF EUT CONSTRUCTIONAL

External Photographs

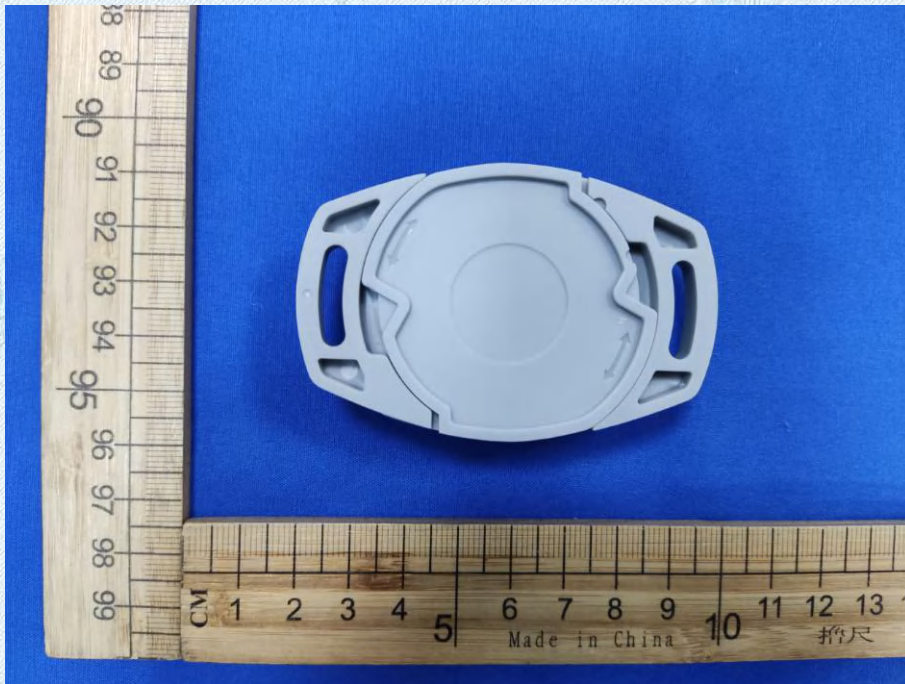

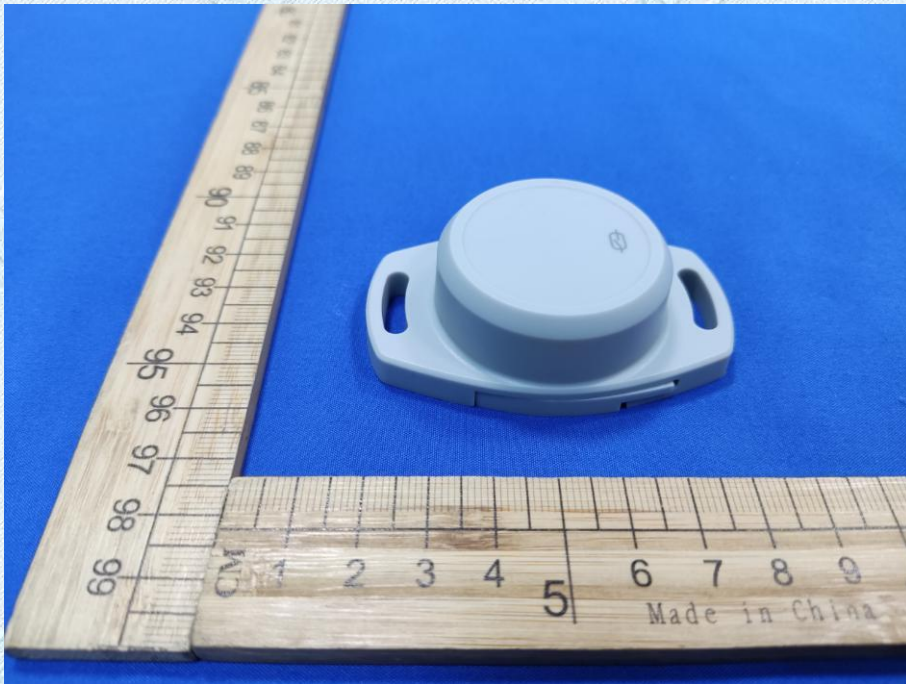

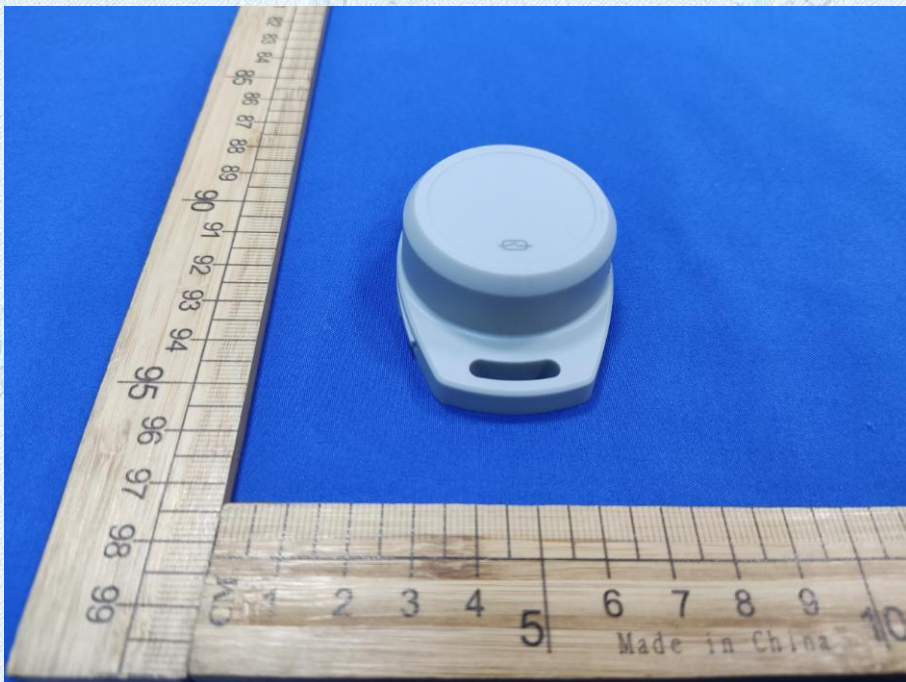
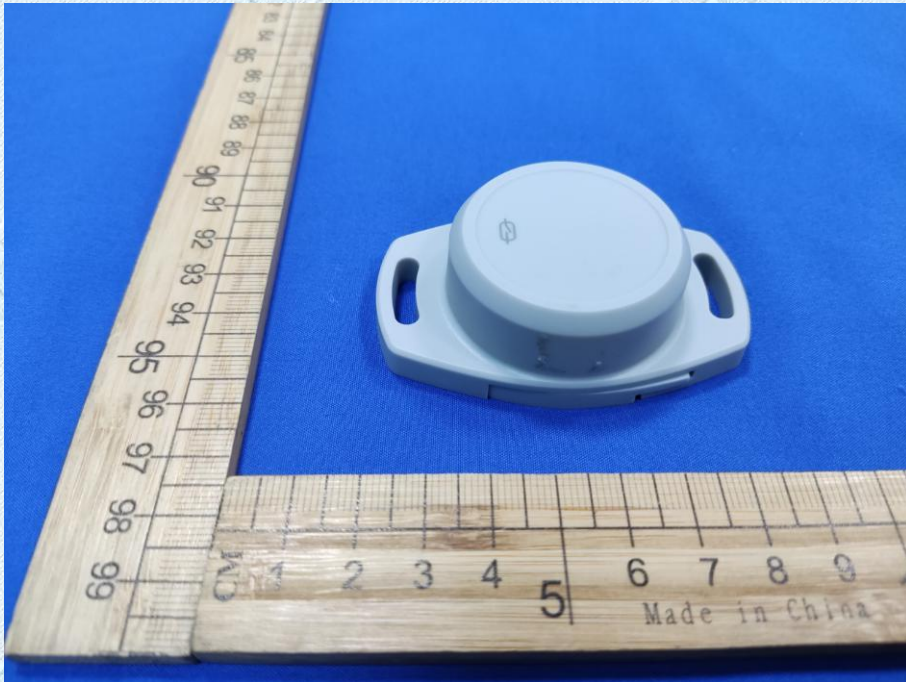

Internal photos



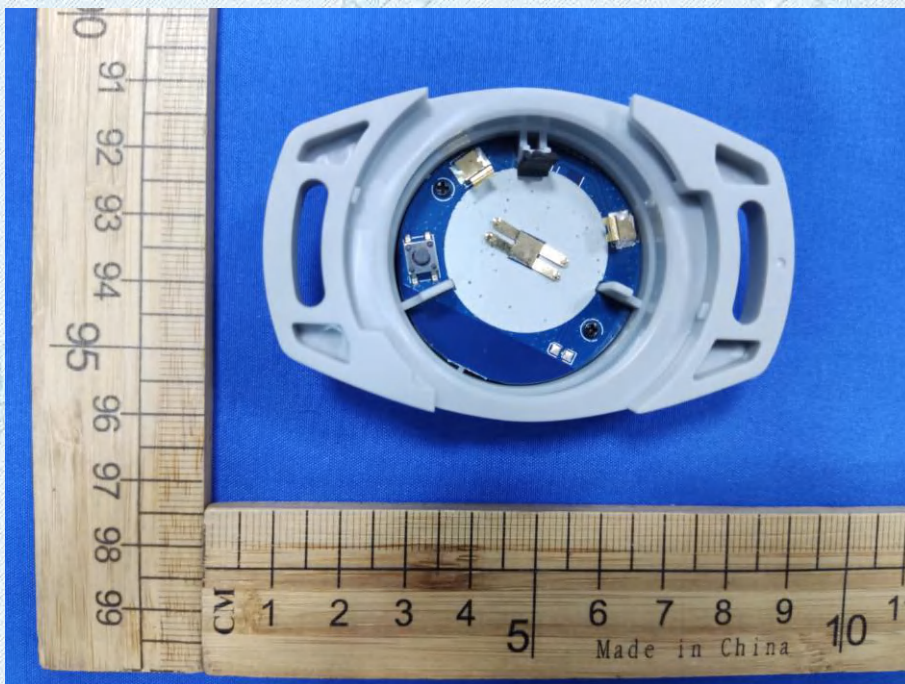

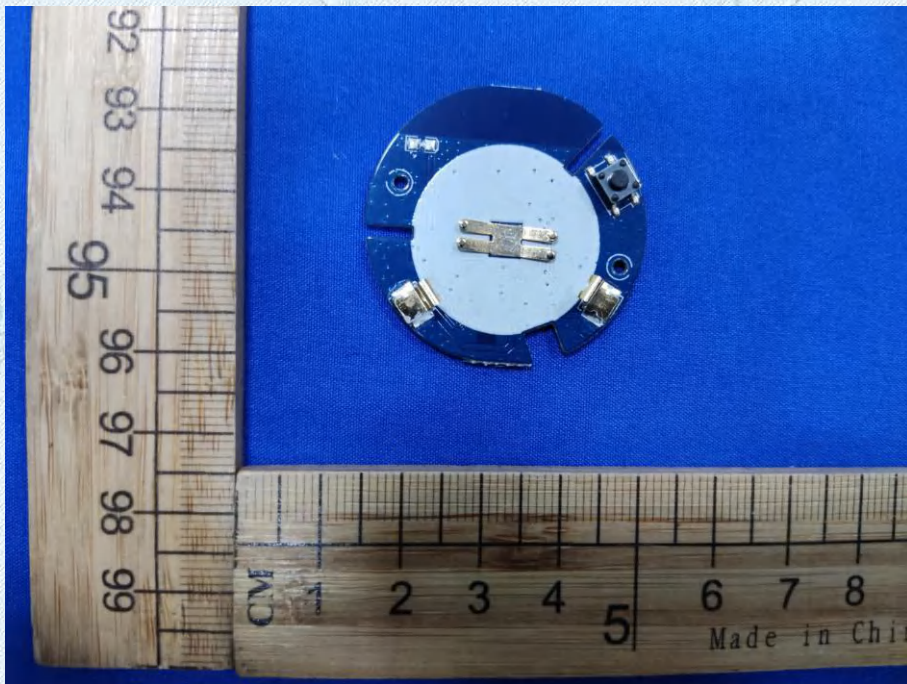

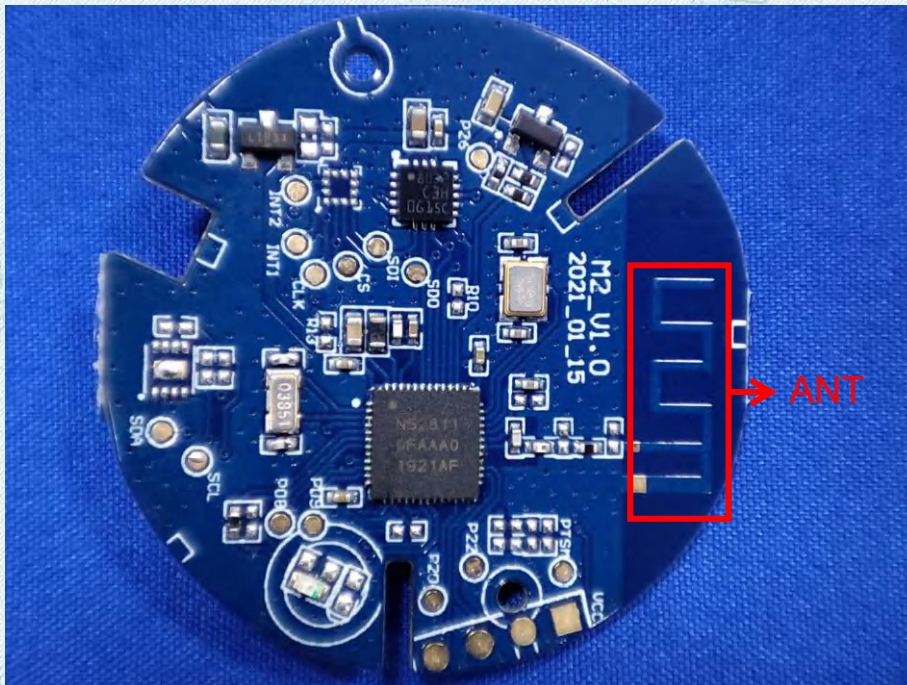
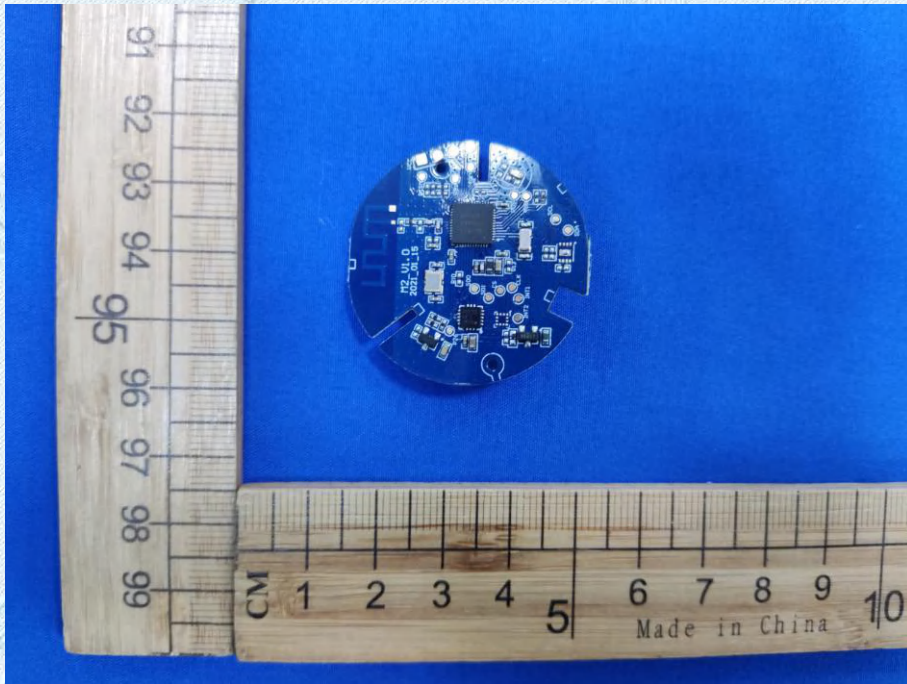

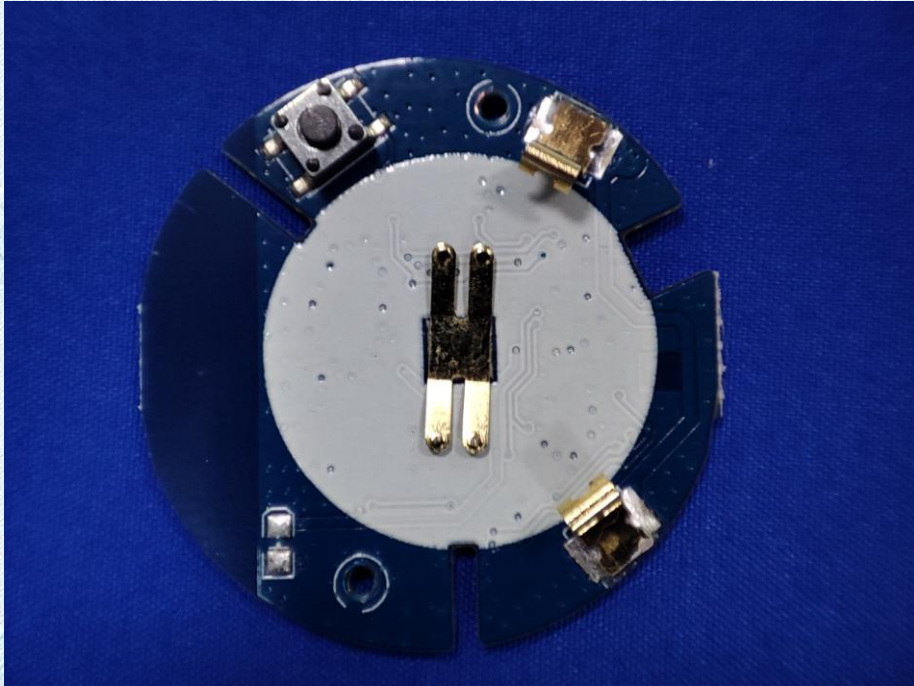

*****THE END*****