



KSIGN (Guangdong) Testing Co., Ltd.

West Side of 1/F., Building C, Zone A, Fuyuan New Factory, Jiujiu Industrial Park,
Minzhu, Shatou, Shajing, Bao'an District, Shenzhen, Guangdong, People's Republic of China
Tel.: + (86)755-29852678 Fax: + (86)755-29852397 E-mail: info@gdksign.cn Website: www.gdksign.com

TEST REPORT

Report No..... : **KS2012S02702EC**

FCC ID..... : **2A094-H5**

Applicant..... : **MOKO TECHNOLOGY LIMITED**

Address..... : 2F, Building1, No.37 Xiaxintang Xintang village, Fucheng Street, Longhua District, Shenzhen, Guangdong Province, China

Manufacturer..... : MOKO TECHNOLOGY Ltd

Address..... : 2F, Building1, No.37 Xiaxintang Xintang village, Fucheng Street, Longhua District, Shenzhen, Guangdong Province, China

Factory..... : MOKO TECHNOLOGY Ltd

Address..... : 2F, Building1, No. 37 Xiaxintang Xintang village, Fucheng Street, Longhua District, Shenzhen, Guangdong Province, China

Product Name..... : **Bluetooth Beacon**

Trade Mark..... : /

Model/Type reference..... : H5

Listed Model(s)..... : H5-INDN-HF, H5-INDA-HF, H5-XNDN-HF, H5-PNDN-HF, H5-PNDNX-HF, H5-PNDA-HF, H5-PNDAX-HF, H5-INDN, H5-INDA, H5-XNDN, H5-PNDN, H5-PNDNX, H5-PNDA, H5-PNDAX

Standard..... : **FCC PART 15 SUBPART C 15.225**
ANSI C63.10: 2013

Date of Receipt..... : Dec. 31, 2020

Date of Test Date..... : Dec. 31, 2020~Apr.08, 2021

Date of issue..... : Apr.08, 2021

Test result..... : **Pass**

Compiled by: Rory Huang
(Printed name+signature)

Supervised by: Eder Zhan
(Printed name+signature)

Approved by: Cary Luo
(Printed name+signature)



Testing Laboratory Name..... : **KSIGN(Guangdong) Testing Co., Ltd.**

Address..... : West Side of 1/F., Building C, Zone A, Fuyuan New Factory, Jiujiu Industrial Park, Minzhu, Shatou, Shajing, Bao'an District, Shenzhen, Guangdong, People's Republic of China

This test report may be duplicated completely for legal use with the approval of the applicant. It should not be reproduced except in full, without the written approval of our laboratory. The client should not use it to claim product endorsement by KSIGN. The test results in the report only apply to the tested sample. The test report shall be invalid without all the signatures of testing engineers, reviewer and approver. Any objections must be raised to KSIGN within 15 days since the date when the report is received. It will not be taken into consideration beyond this limit. The test report merely correspond to the test sample.

TABLE OF CONTENTS**Page**

1. TEST SUMMARY.....	3
1.1. TEST STANDARDS.....	3
1.2. REPORT VERSION.....	3
1.3. TEST DESCRIPTION.....	4
1.4. TEST FACILITY.....	5
1.5. MEASUREMENT UNCERTAINTY.....	6
1.6. ENVIRONMENTAL CONDITIONS.....	6
2. GENERAL INFORMATION.....	7
2.1. CLIENT INFORMATION.....	7
2.2. GENERAL DESCRIPTION OF EUT.....	7
2.3. TEST MODE.....	7
2.4. MEASUREMENT INSTRUMENTS LIST.....	8
2.5. TEST SOFTWARE.....	8
3. TEST ITEM AND RESULTS.....	9
3.1. ANTENNA REQUIREMENT.....	9
3.2. OCCUPIED BANDWIDTH.....	10
3.3. FREQUENCY STABILITY.....	12
3.4. SPURIOUS EMISSION (RADIATED).....	14
3.5. CONDUCTED EMISSION.....	20
4. EUT TEST PHOTOS.....	22
5. PHOTOGRAPHS OF EUT CONSTRUCTIONAL.....	24

1. TEST SUMMARY

1.1. Test Standards

The tests were performed according to following standards:

FCC Rules Part 15.225: Operation within the band 13.110-14.010 MHz.

ANSI C63.10-2013: American National Standard for Testing Unlicensed Wireless Devices.

1.2. Report version

Revised No.	Date of issue	Description
01	Apr.08, 2021	Original

1.3. Test Description

FCC Rules Part 15.225			
Test Item	Standard Section	Result	Test Engineer
	FCC		
Antenna Requirement	15.203	Pass	Rory Huang
Conducted Emissions	15.207	N/A	N/A
Radiated Spurious Emissions	FCC Part 15.225&15.205&15.209	Pass	Rory Huang
Frequency Tolerance	FCC Part 15.225e	Pass	Rory Huang
Occupied Bandwidth	FCC Part 15.215c	Pass	Rory Huang

Note: 1. The measurement uncertainty is not included in the test result.

2.N/A: means this test item is not applicable

1.4. Test Facility

Address of the report laboratory

KSIGN(Guangdong) Testing Co., Ltd.

West Side of 1/F., Building C, Zone A, Fuyuan New Factory, Jiujiu Industrial Park, Minzhu, Shatou, Shajing, Bao'an District, Shenzhen, Guangdong, People's Republic of China

Laboratory accreditation

The test facility is recognized, certified, or accredited by the following organizations:

CNAS-Lab Code: L13261

KSIGN(Guangdong) Testing Co., Ltd. has been assessed and proved to be in Compliance with CNAS-CL01 Accreditation Criteria for Testing and Calibration Laboratories (identical to ISO/IEC17025: 2017 General Requirements) for the Competence of Testing and Calibration Laboratories.

A2LA-Lab Cert. No.: 5457.01

KSIGN(Guangdong) Testing Co., Ltd. EMC Laboratory has been accredited by A2LA for technical competence in the field of electrical testing, and proved to be in compliance with ISO/IEC 17025:2017 General Requirements for the Competence of Testing and Calibration Laboratories and any additional program requirements in the identified field of testing.

IC Registration No.: CN0096

The 3m alternate test site of KSIGN(Guangdong) Testing Co., Ltd. EMC Laboratory has been registered by Certification and Engineer Bureau of Industry Canada for the performance of with Registration NO.: CN0096

FCC-Registration No.: CN1272

KSIGN(Guangdong) Testing Co., Ltd. EMC Laboratory has been registered and fully described in a report filed with the (FCC) Federal Communications Commission. The acceptance letter from the FCC is maintained in our files.

1.5. Measurement Uncertainty

The data and results referenced in this document are true and accurate. The reader is cautioned that there may be errors within the calibration limits of the equipment and facilities. The measurement uncertainty was calculated for all measurements listed in this test report acc. to TR-100028-01 "Electromagnetic compatibility and Radio spectrum Matters (ERM);Uncertainties in the measurement of mobile radio equipment characteristics; Part 1" and TR-100028-02 "Electromagnetic compatibility and Radio spectrum Matters (ERM);Uncertainties in the measurement of mobile radio equipment characteristics; Part 2 " and is documented in the KSIGN(Guangdong) Testing Co., Ltd. system acc. to DIN EN ISO/IEC 17025. Furthermore, component and process variability of devices similar to that tested may result in additional deviation. The manufacturer has the sole responsibility of continued compliance of the device. Below is the best measurement capability for KSIGN(Guangdong) Testing Co., Ltd.

Test Items	Measurement Uncertainty	Notes
Transmitter power conducted	0.42 dB	(1)
Transmitter power Radiated	2.14 dB	(1)
Conducted spurious emissions 9kHz~40GHz	1.60 dB	(1)
Radiated spurious emissions 9kHz~40GHz	2.20 dB	(1)
Conducted Emissions 9kHz~30MHz	3.20 dB	(1)
Radiated Emissions 30~1000MHz	4.70 dB	(1)
Radiated Emissions 1~18GHz	5.00 dB	(1)
Radiated Emissions 18~40GHz	5.54 dB	(1)
Occupied Bandwidth	2.80 dB	(1)

Note (1): This uncertainty represents an expanded uncertainty expressed at approximately the 95% confidence level using a coverage factor of k=1.96.

1.6. Environmental conditions

During the measurement the environmental conditions were within the listed ranges:

Temperature:	15~35°C
Relative Humidity:	30~60 %
Air Pressure:	950~1050mba

2. GENERAL INFORMATION

2.1. Client Information

Applicant:	MOKO TECHNOLOGY LIMITED
Address:	2F, Building1, No.37 Xiaxintang Xintang village, Fucheng Street, Longhua District, Shenzhen, Guangdong Province, China
Manufacturer:	MOKO TECHNOLOGY Ltd
Address:	2F, Building1, No.37 Xiaxintang Xintang village, Fucheng Street, Longhua District, Shenzhen, Guangdong Province, China

2.2. General Description of EUT

Test Sample Number:	1-1-1(Normal Sample), 1-1-2(Engineering Sample)
Product Name:	Bluetooth Beacon
Model/Type reference:	/
Trademark:	H5
Listed models:	H5-INDN-HF, H5-INDA-HF, H5-XNDN-HF, H5-PNDN-HF, H5-PNDNX-HF, H5-PNDA-HF, H5-PNDAX-HF, H5-INDN, H5-INDA, H5-XNDN, H5-PNDN, H5-PNDNX, H5-PNDA, H5-PNDAX
Model Difference:	The difference between product models only depends on the appearance color and the model naming is different. Other power supply methods, safety structure and key components are the same, which do not affect the safety and electromagnetic compatibility performance.
Power supply:	/
Power supply(Battery):	Input:DC 3.0V
Hardware version:	V1.0
Software version:	V1.0.0
RF Specification	
Operation frequency:	13.56MHz
Modulation Type:	ASK
Modulation connector:	<input checked="" type="checkbox"/> Without external <input type="checkbox"/> External
Channel number:	1
Antenna type:	Coil antenna
Antenna gain:	0dBi

2.3. Test Mode

The EUT was operated at continuous transmitting mode that was for the purpose of the measurements. All testing shall be performed under maximum output power condition, and to measure its highest possible emissions level, more detailed description as follows:

Test Mode	Description	Remark
1	TX (13.56MHz)	DC 3.0V

2.4. Measurement Instruments List

Tonscend JS0806-2 Test system					
Item	Test Equipment	Manufacturer	Model No.	Serial No.	Cal. Until
1	Spectrum Analyzer	R&S	FSV40-N	101798	03/22/2022
2	Vector Signal Generator	Agilent	N5182A	MY50142520	03/18/2022
3	Analog Signal Generator	HP	83752A	3344A00337	03/18/2022
4	Power Sensor	Agilent	E9304A	MY50390009	03/18/2022
5	Power Sensor	Agilent	E9300A	MY41498315	03/18/2022
6	Wideband Radio Communication Tester	R&S	CMW500	157282	03/18/2022
7	Climate Chamber	Angul	AGNH80L	1903042120	03/18/2022
8	Dual Output DC Power Supply	Agilent	E3646A	MY40009992	03/18/2022
9	RF Control Unit	Tonscend	JS0806-2	/	03/18/2022

Transmitter spurious emissions & Receiver spurious emissions					
Item	Test Equipment	Manufacturer	Model No.	Serial No.	Cal. Until
1	EMI Test Receiver	R&S	ESR	102525	03/18/2022
2	High Pass Filter	Chengdu E-Microwave	OHF-3-18-S	0E01901038	03/22/2022
3	High Pass Filter	Chengdu E-Microwave	OHF-6.5-18-S	0E01901039	03/22/2022
4	Spectrum Analyzer	HP	8593E	3831U02087	03/22/2022
5	Ultra-Broadband logarithmic period Antenna	Schwarzbeck	VULB 9163	01230	03/29/2023
6	Loop Antenna	Beijin ZHINAN	ZN30900C	18050	03/27/2022
7	Spectrum Analyzer	R&S	FSV40-N	101798	03/22/2022
8	Horn Antenna	Schwarzbeck	BBHA 9120 D	2023	03/29/2023
9	Pre-Amplifier	Schwarzbeck	BBV 9745	9745#129	03/22/2022
10	Pre-Amplifier	EMCI	EMC051835SE	980662	03/22/2022

Item	Test Equipment	Manufacturer	Model No.	Serial No.	Cal. Until
1	LISN	R&S	ENV432	1326.6105.02	03/27/2022
2	EMI Test Receiver	R&S	ESR	102524	04/07/2022
3	Manual RF Switch	JS TOYO	/	MSW-01/002	04/07/2022

Note:

1)The Cal. Interval was one year.

2)The cable loss has calculated in test result which connection between each test instruments.

2.5. Test Software

Software name	Model	Version
Conducted emission Measurement Software	EZ-EMC	EMC-Con 3A1.1
Radiated emission Measurement Software	EZ-EMC	FA-03A.2.RE
Bluetooth and WIFI Test System	JS1120-3	2.5.77.0418

3. TEST ITEM AND RESULTS

3.1. Antenna requirement

Requirement

FCC CFR Title 47 Part 15 Subpart C Section 15.203:

An intentional radiator shall be designed to ensure that no antenna other than that furnished by the responsible party shall be used with the device. The use of a permanently attached antenna or of an antenna that uses a unique coupling to the intentional radiator, the manufacturer may design the unit so that a broken antenna can be replaced by the user, but the use of a standard antenna jack or electrical connector is prohibited.

FCC CFR Title 47 Part 15 Subpart C Section 15.247(c) (1)(i):

(i) Systems operating in the 13.110~14.010 MHz band that is used exclusively for fixed. Point-to-point operations may employ transmitting antennas with directional gain greater than 6dBi provided the maximum conducted output power of the intentional radiator is reduced by 1 dB for every 3 dB that the directional gain of the antenna exceeds 6dBi.

Test Result

The directional gain of the antenna less than 6dBi, please refer to the EUT internal photographs antenna photo.

Note: The antenna is permanently fixed to the EUT

3.2. Occupied Bandwidth

Limit

The bandwidth of the emission shall be no wider than 80% of the center frequency.

Test Configuration

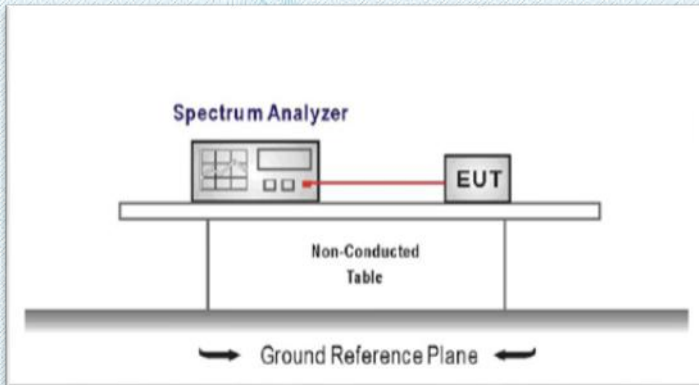

Test Procedure

1. Connect EUT RF output port to the Spectrum Analyzer through an RF attenuator
2. Set the EUT Work on the operation frequency.
3. Set SPA Centre Frequency = Operation Frequency, $RBW = 10 \text{ KHz}$, $VBW \geq 3 \times RBW$.
4. Set SPA Trace 1 Max hold, then View.
5. Measure and record the results in the test report.

Test Mode

Please refer to the clause 2.3.

Test Results

Channel frequency (MHz)	99%Bandwidth (kHz)	-20dB Bandwidth (kHz)	Criteria
13.56	21.128	24.89	Pass

99%Bandwidth

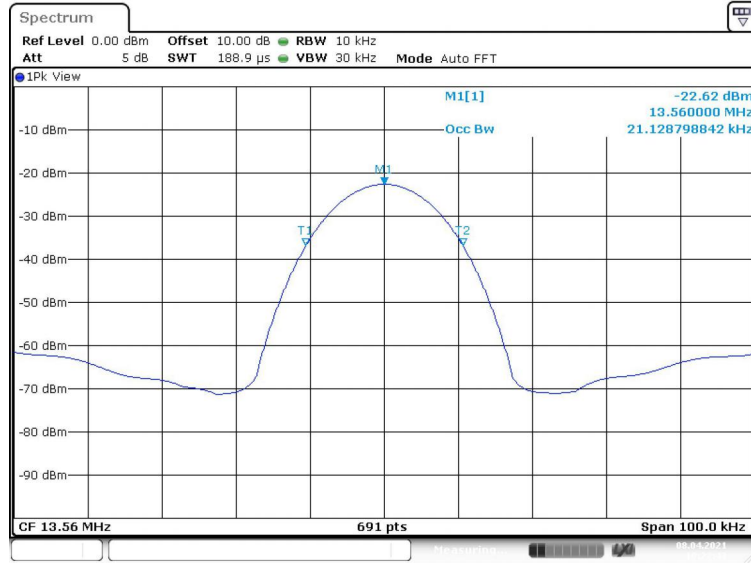

-20dB Bandwidth

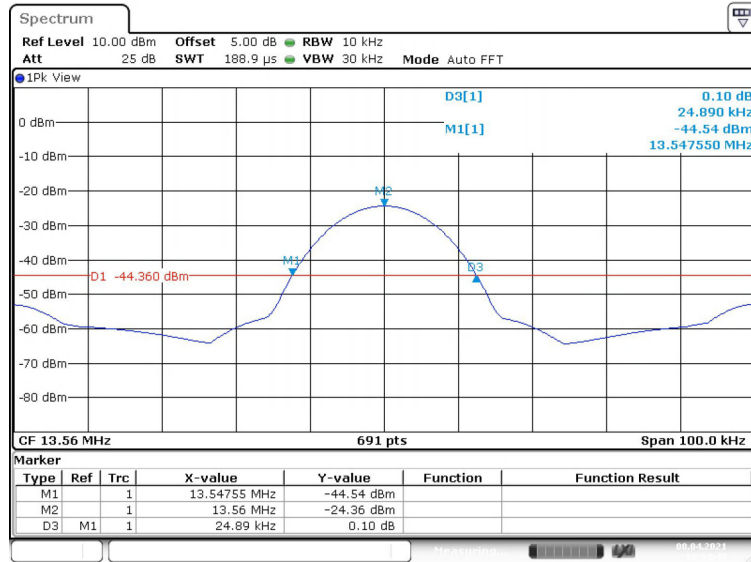

3.3. Frequency Stability

Limit

The frequency tolerance of the carrier signal shall be maintained within $\pm 0.01\%$.

Test Configuration

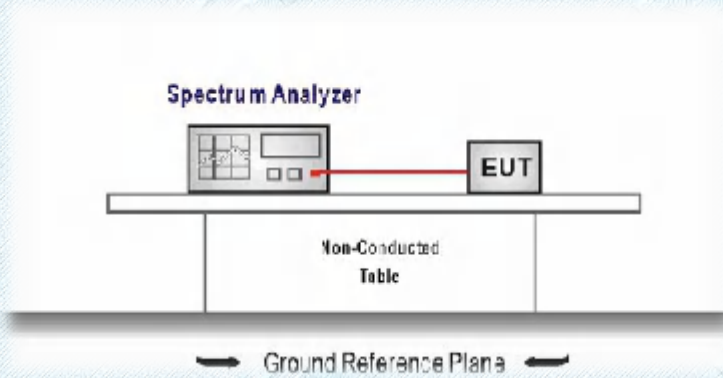

Test Procedure

1. Connect EUT RF output port to the Spectrum Analyzer through an RF attenuator
2. Set the EUT Work on the operation frequency.
3. Set SPA Centre Frequency = Operation Frequency, RBW= 1 KHz, VBW $\geq 3 \times$ RBW.
4. Set SPA Trace 1 Max hold, then View.
5. The test extreme voltage is to change the primary supply voltage from 85 to 115 percent of the nominal value
6. Extreme temperature rule is -20° C~ 50° C.
7. Measure and record the results in the test report.

Test Mode

Please refer to the clause 2.3.

Test Results

Test Frequency: 13.56MHz

Voltage vs. Frequency Stability (Test Temperature: 20°C)

Voltage(V)	Measurement Frequency (MHz)	Max. Deviation (MHz)	Limit(MHz)	Conclusion
3.0	13.56031	0.00060	0.001356	PASS
2.55	13.56060			
3.45	13.56057			

Temperature vs. Frequency Stability (Test Voltage: 3.0V)

Temperature	Measurement Frequency (MHz)	Max. Deviation (MHz)	Limit(MHz)	Conclusion
-20°C	13.56061	0.00060	0.001356	PASS
-10°C	13.56060			
0°C	13.56060			
10°C	13.56042			
20°C	13.56059			
30°C	13.56060			
40°C	13.56058			
50°C	13.56053			

Note: EUT uses a new battery test.

3.4. Spurious Emission (Radiated)

Limit

Within the 13.110MHz-14.010MHz band

Frequencies (MHz)	Field Strength at 30m (microvolts/meter)	Field Strength at 30m (dBuV/m)	Field Strength at 3m (dBuV/m)
13.553~13.567	15.848	84	124
13.410~13.553 13.567~13.710	334	50.5	90.5
13.110~13.410 13.710~14.010	106	40.5	80.5

According to 15.35, on any frequency or frequencies below or equal to 1000 MHz, the limits shown are based on measuring equipment employing a CISPR quasi-peak detector function and related measurement bandwidths, unless otherwise specified the limit on peak radio frequency emissions is 20dB above the maximum permitted average emission limit applicable to the equipment under test.

Outside of the 13.110MHz-14.010MHz band

Frequency (MHz)	Distance Meters	Field Strengths Limit	
		$\mu V/m$	dB(μV)/m
0.009 ~ 0.490	300	2400/F(kHz)	---
0.490 ~ 1.705	30	24000/F(kHz)	---
1.705 ~ 30	30	30	---
30 ~ 88	3	100	40.0
88 ~ 216	3	150	43.5
216 ~ 960	3	200	46.0
960 ~ 1000	3	500	54.0
Above 1000	3	Other:74.0 dB(μV)/m (Peak) 54.0 dB(μV)/m (Average)	

Remark: (1) Emission level dB $\mu V = 20 \log$ Emission level $\mu V/m$
(2) The smaller limit shall apply at the cross point between two frequency bands.
(3) Distance is the distance in meters between the measuring instrument, antenna and the closest point of any part of the device or system.

Test Configuration

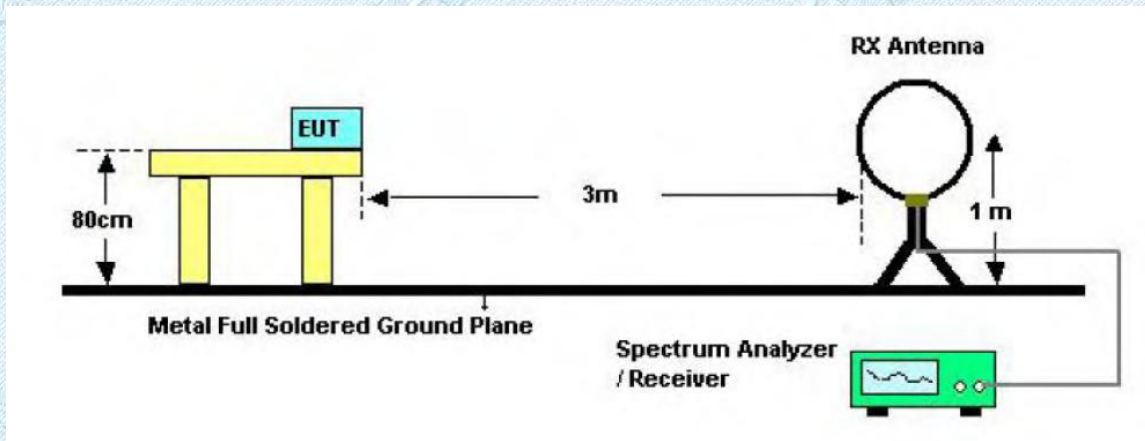

Below 30MHz Test Setup

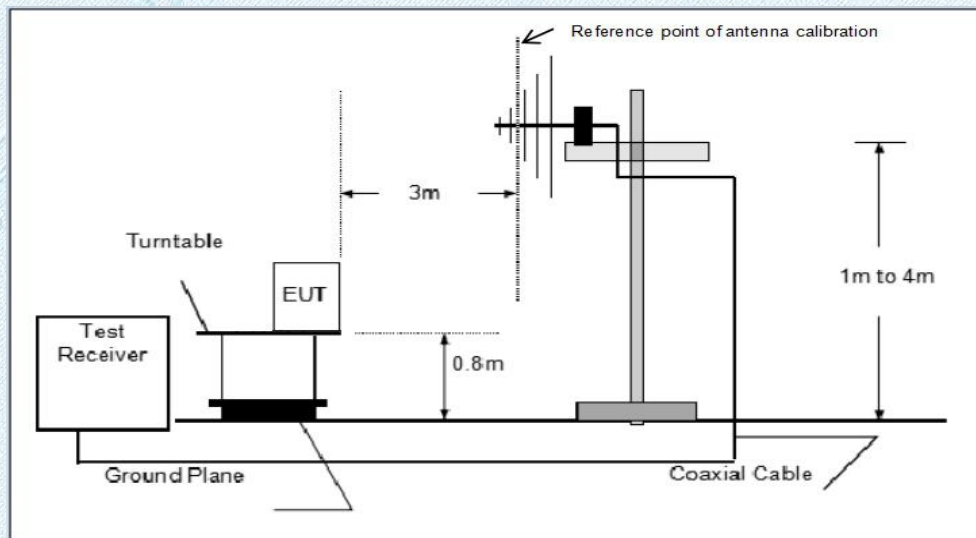

Below 1000MHz Test Setup

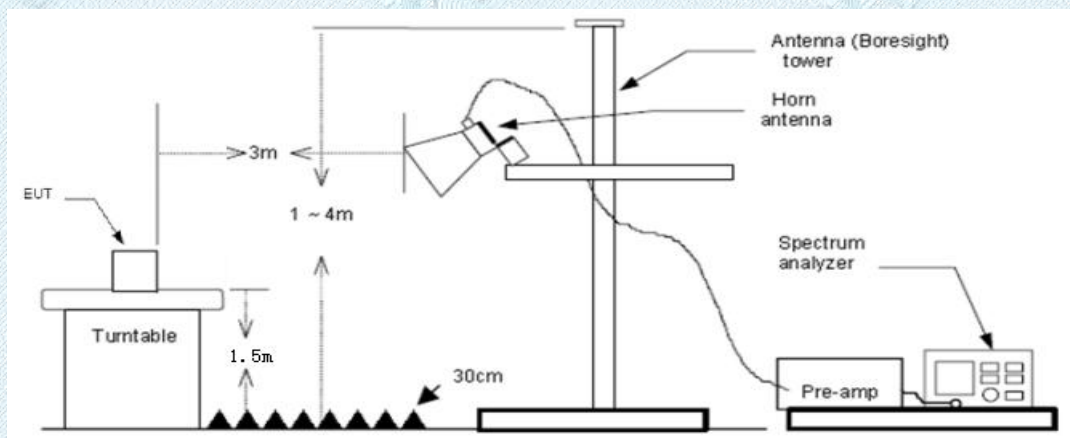

Above 1GHz Test Setup

Test Procedure

1. The EUT was setup and tested according to ANSI C63.10:2013
2. The EUT is placed on a turn table which is 0.8 meter above ground for below 1 GHz, and 1.5 m for above 1 GHz. The turn table is rotated 360 degrees to determine the position of the maximum emission level.
3. The EUT was set 3 meters from the receiving antenna, which was mounted on the top of a variable height antenna tower.
4. For each suspected emission, the EUT was arranged to its worst case and then tune the Antenna tower (from 1 m to 4 m) and turntable (from 0 degree to 360 degrees) to find the maximum reading. A pre-amp and a high pass filter are used for the test in order to get better signal level to comply with the guidelines.
5. Set to the maximum power setting and enable the EUT transmit continuously.
6. Use the following spectrum analyzer settings
 - (1) Span shall wide enough to fully capture the emission being measured;
 - (2) Below 1 GHz:
RBW=120 kHz, VBW=300 kHz, Sweep=auto, Detector function=peak, Trace=max hold;
If the emission level of the EUT measured by the peak detector is 3 dB lower than the applicable limit, the peak emission level will be reported. Otherwise, the emission measurement will be repeated using the quasi-peak detector and reported.
 - (3) From 1 GHz to 10th harmonic:
RBW=1MHz, VBW=3MHz Peak detector for Peak value.
RBW=1MHz, VBW=10Hz Peak detector for Average value.

Test Mode

Please refer to the clause 2.3.

Test Result

9 KHz~30 MHz , 30MHz-1GHz and 1GHz~5GHz

From 9 KHz~30 MHz, 30MHz-1GHz and 1GHz~5GHz: Conclusion: PASS

Note:

- 1) Final level = Reading level + Correct Factor
Correct Factor=Antenna Factor + Cable Loss -Preamplifier Factor
- 2) The emission levels of other frequencies are very lower than the limit and not show in test report.
- 3) The amplitude of spurious emissions which are attenuated by more than 20dB below the permissible value has no need to be reported.

RADIATED EMISSION BELOW 30MHZ

Test Voltage:	DC 3.0V
Test Mode:	TX 13.56MHz

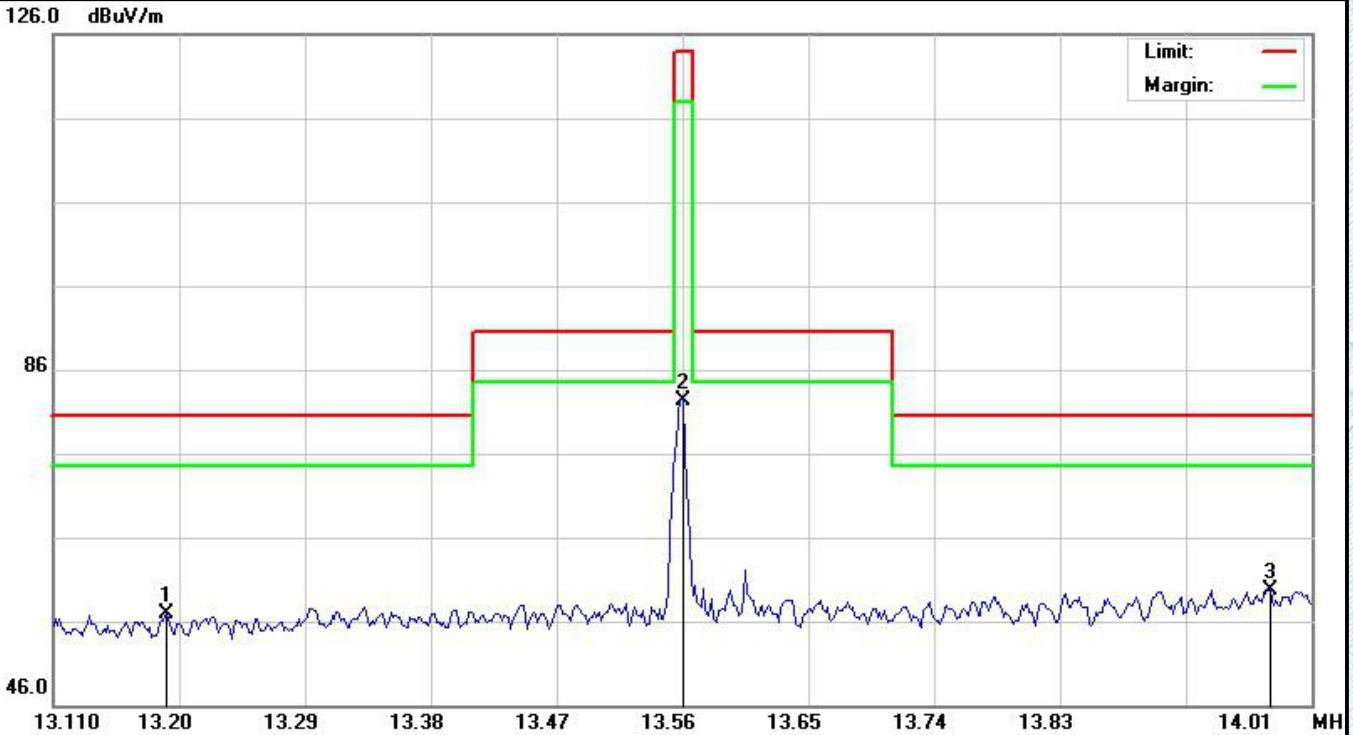

No.	Mk	Freq.	Reading	Factor	Measurement	Limit	Over	Detector
		MHz	dBuV	dBuV/m	dBuV/m	dBuV/m	dB	
1		13.1910	-8.09	65.00	56.91	80.50	-23.59	peak
2		13.5600	17.40	65.00	82.40	124.00	-41.60	peak
3	*	13.9800	-5.21	65.00	59.79	80.50	-20.71	peak

Emission Level= Read Level+ Factor

■ 30MHz~ 1000MHz

Test Voltage:	DC 3.0V
Ant. Pol.	Horizontal
Test Mode:	TX 13.56MHz

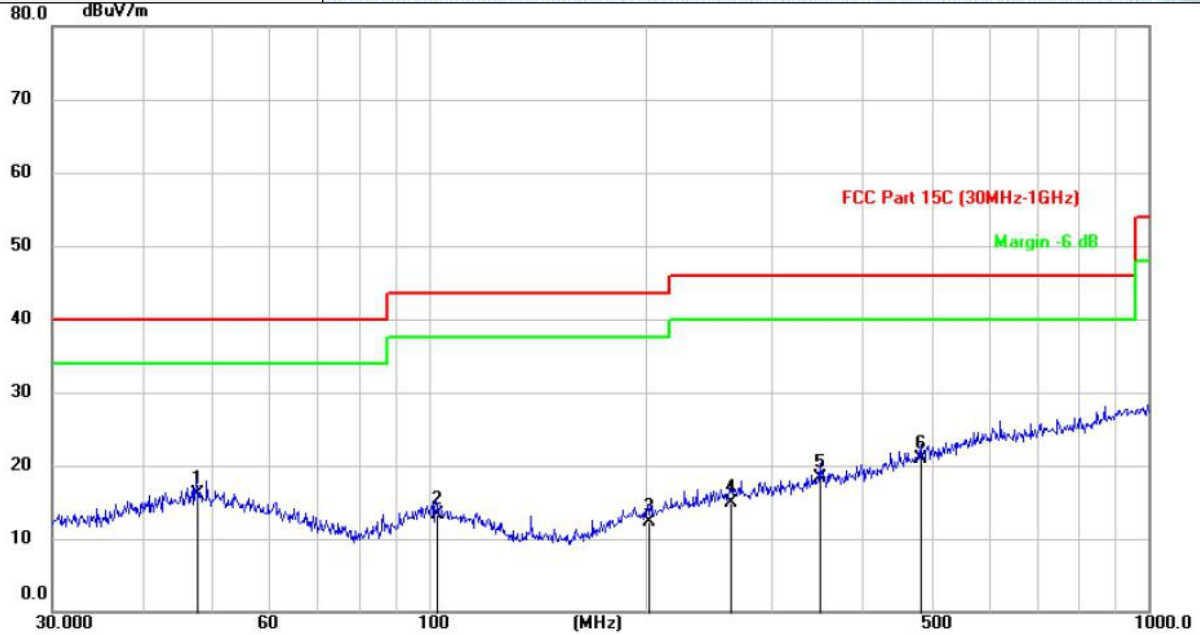

No.	Mk.	Freq. MHz	Reading Level (dBuV)	Correct Factor (dB/m)	Measure- ment (dBuV/m)	Limit (dBuV/m)	Over (dB)	Detector
1	*	47.5583	26.68	-10.49	16.19	40.00	-23.81	QP
2		102.5391	26.17	-12.77	13.40	43.50	-30.10	QP
3		202.0295	25.67	-13.27	12.40	43.50	-31.10	QP
4		262.3428	26.10	-11.14	14.96	46.00	-31.04	QP
5		349.9854	27.59	-9.30	18.29	46.00	-27.71	QP
6		482.8924	27.60	-6.63	20.97	46.00	-25.03	QP

Correct Factor=Antenna Factor + Cable Loss -Preamplifier Factor

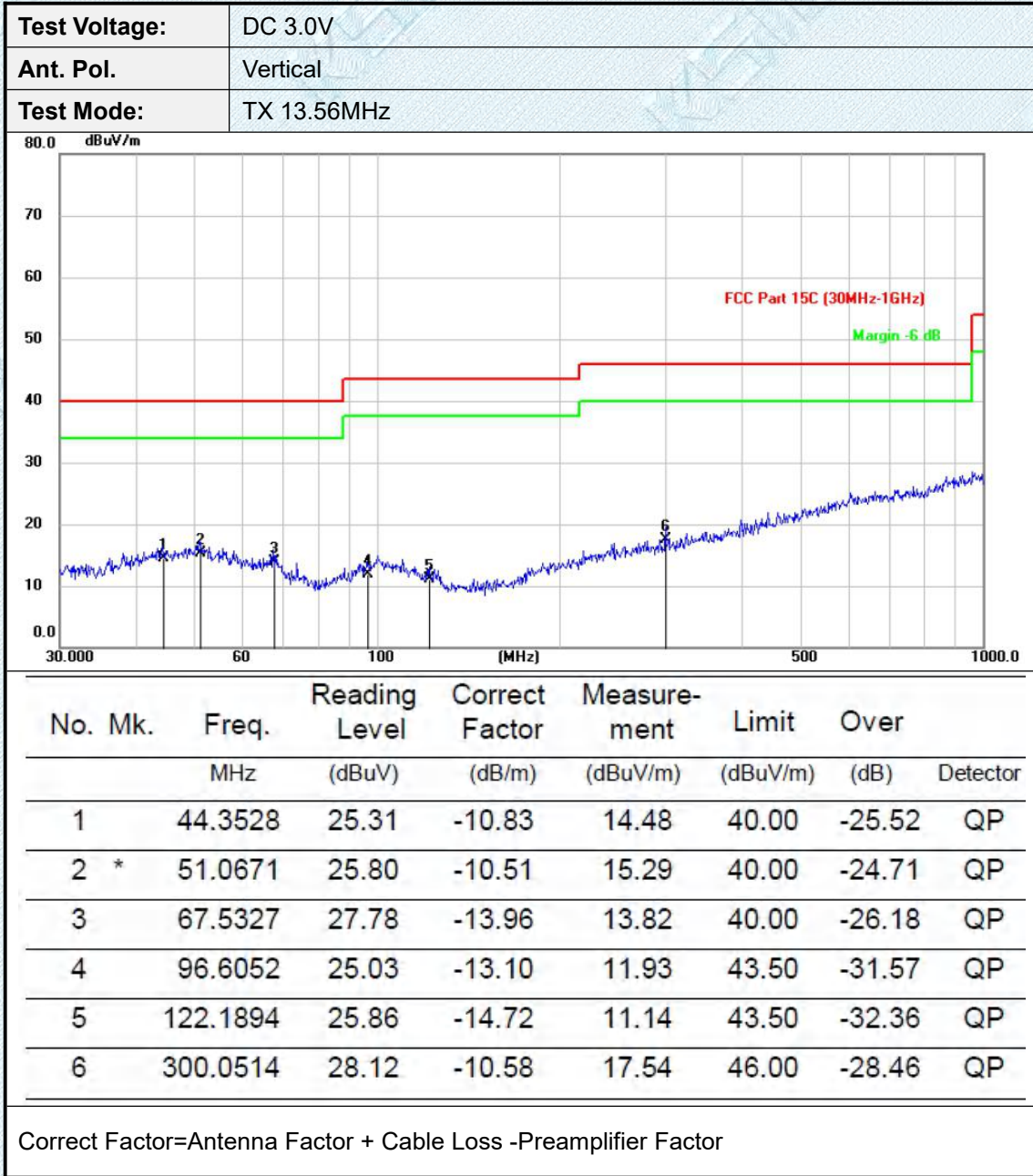

3.5. Conducted Emission

Limit

Conducted Emission Test Limit

Frequency	Maximum RF Line Voltage (dB μ V)	
	Quasi-peak Level	Average Level
150kHz~500kHz	66 ~ 56 *	56 ~ 46 *
500kHz~5MHz	56	46
5MHz~30MHz	60	50

Notes:

- (1) *Decreasing linearly with logarithm of the frequency.
- (2) The lower limit shall apply at the transition frequencies.
- (3) The limit decrease in line with the logarithm of the frequency in the range of 0.15 to 0.50MHz.

Test Configuration

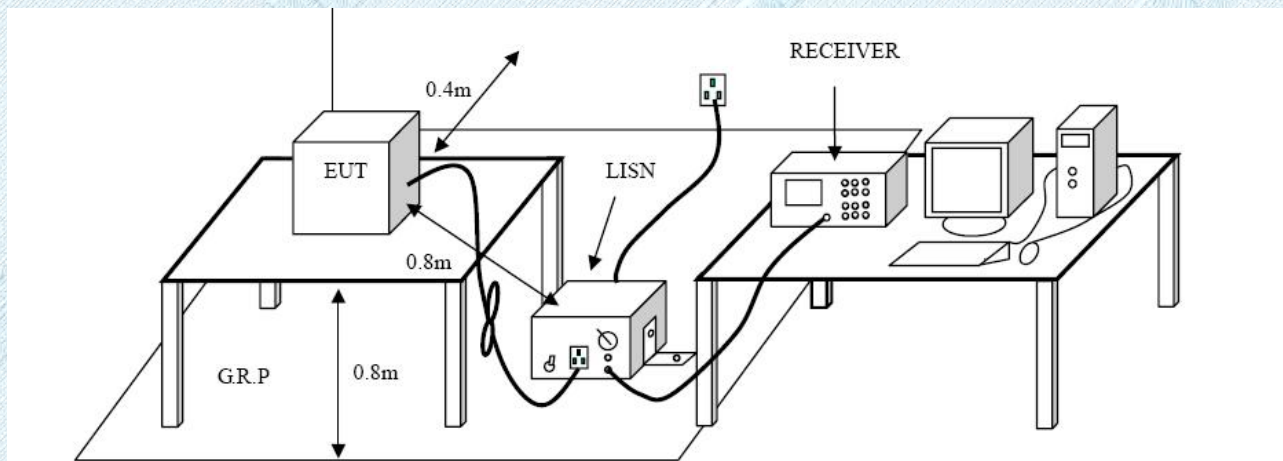

Test Procedure

1. The EUT was setup according to ANSI C63.10:2013 requirements.
2. The EUT was placed on a platform of nominal size, 1 m by 1.5 m, raised 80 cm above the conducting ground plane. The vertical conducting plane was located 40 cm to the rear of the EUT. All other surfaces of EUT were at least 80 cm from any other grounded conducting surface.
3. The EUT and simulators are connected to the main power through a line impedances stabilization network (LISN). The LISN provides a 50ohm /50uH coupling impedance for the measuring equipment.
The peripheral devices are also connected to the main power through a LISN. (Please refer to the block diagram of the test setup and photographs)
4. Each current-carrying conductor of the EUT power cord, except the ground (safety) conductor, was individually connected through a LISN to the input power source.
5. The excess length of the power cord between the EUT and the LISN receptacle were folded back and forth at the center of the lead to form a bundle not exceeding 40 cm in length.
6. Conducted Emissions were investigated over the frequency range from 0.15MHz to 30MHz using a receiver bandwidth of 9 kHz.
7. During the above scans, the emissions were maximized by cable manipulation.

Test Mode:

Please refer to the clause 2.3.

Test Results

Passed Not Applicable

4.EUT TEST PHOTOS

Radiated Measurement (9KHz~30MHz)

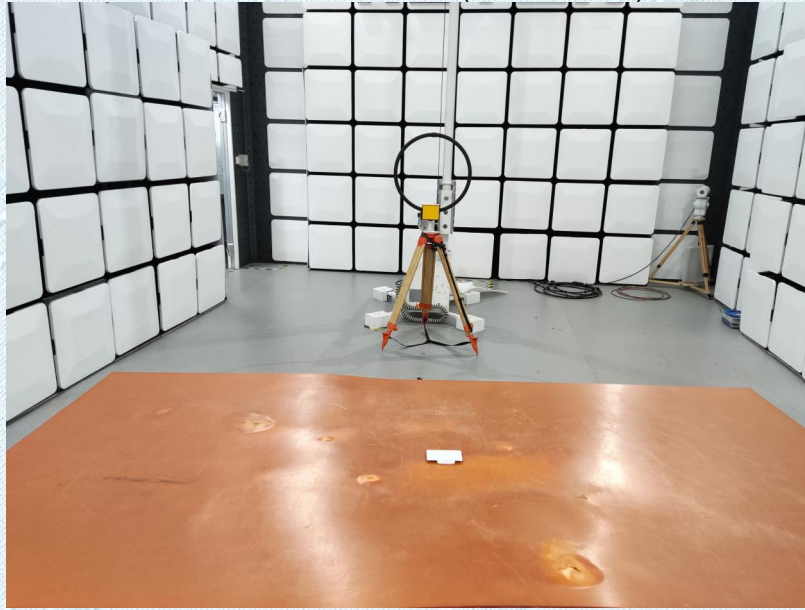

Radiated Measurement (30MHz~ 1GHz)

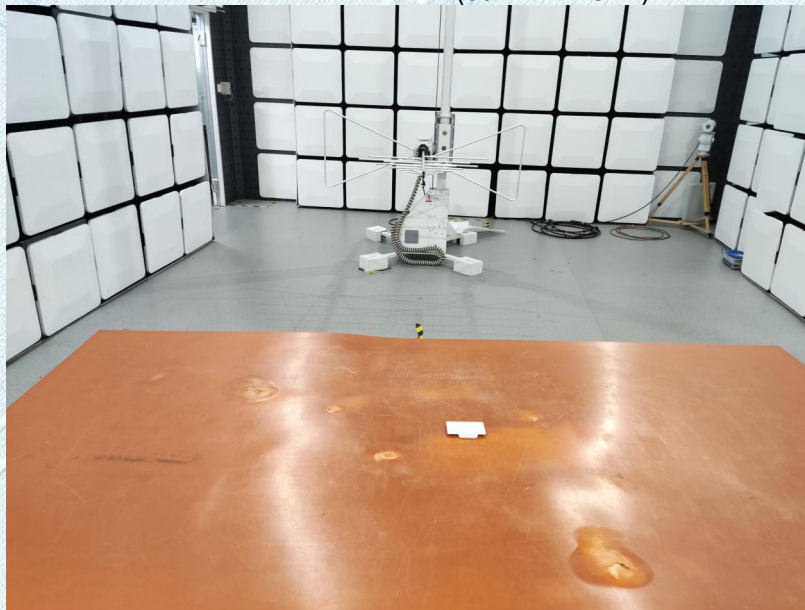

Radiated Measurement (Above 1GHz)



5. PHOTOGRAPHS OF EUT CONSTRUCTIONAL

Reference to the document No.: External Photos and Internal Photos.

*****THE END*****