

netvue

Orb Pro Quick Guide

NI-3231

Catalogue

1. Warning	P. 1
2. What's In The Box	P. 2
3. Camera Structure	P. 3-4
4. Read Before Installing	P. 5
5. Set Up With Netvue App	P. 6
6. Mount Your Orb Pro	P. 7-10
7. Status Light	P. 11
8. Netvue Protect Plan	P. 12
9. Contact Us	P. 13

FCC Warning

This device complies with part 15 of the FCC rules. Operation is subject to the following two conditions: (1) this device may not cause harmful interference, and (2) this device must accept any interference received, including interference that may cause undesired operation.

Changes or modifications not expressly approved by the party responsible for compliance could void the user's authority to operate the equipment.

NOTE: This equipment has been tested and found to comply with the limits for a Class B digital device, pursuant to part 15 of the FCC Rules. These limits are designed to provide reasonable protection against harmful interference in a residential installation. This equipment generates uses and can radiate radio frequency energy and, if not installed and used in accordance with the instructions, may cause harmful interference to radio communications. However, there is no guarantee that interference will not occur in a particular installation. If this equipment does cause harmful interference to radio or television reception, which can be determined by turning the equipment off and on, the user is encouraged to try to correct the interference by one or more of the following measures:

- Reorient or relocate the receiving antenna.
- Increase the separation between the equipment and receiver.
- Connect the equipment into an outlet on a circuit different from that to which the receiver is connected.
- Consult the dealer or an experienced radio/TV technician for help.

Radiation Exposure Statement

This equipment complies with FCC radiation exposure limits set forth for an uncontrolled environment. This equipment should be installed and operated with minimum distance 20cm between the radiator and your body.

FCC ID 2A08RNI-3231

CE RED

This product can be used across EU member states.

What's In The Box

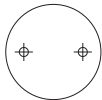

Drilling Template



Mounting Bracket



Quick Guide



Power Adapter

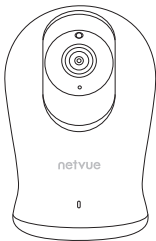

Orb Pro



X 2

Mounting Screws



X 2

Anchors

Camera Structure

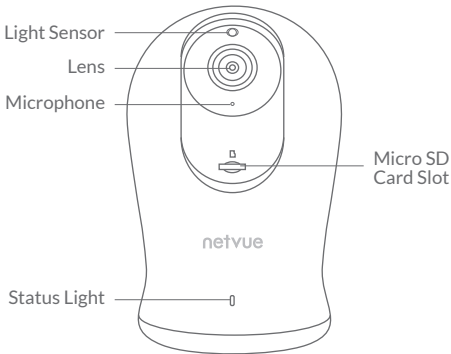

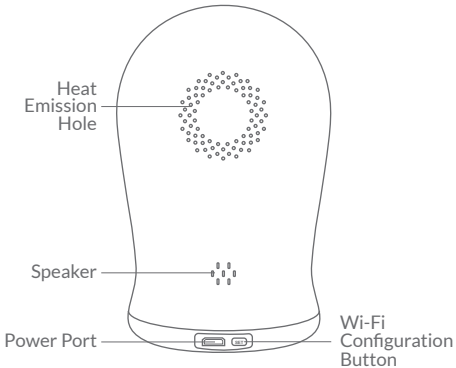

Read Before Installing

1. Keep Orb Pro and all accessories out of reach of children and pets.
2. Orb Pro comes with a power adapter. If you prefer other power adapters, please make sure that they allow a DC5V power supply voltage, and an electric current not less than 1A .
3. Working temperature: -10°C to 50°C (14°F to 122°F)
Working relative humidity: 0-95%
4. Please do not expose the camera lens to direct sunlight.

Note:

1. Netvue Orb Pro only works with 2.4GHz Wi-Fi.
2. Strong lights may interfere with the device's ability to scan QR code.
3. Avoid placing the device behind furniture or near microwaves. Try to keep it within range of your Wi-Fi signal.

Set Up With Netvue App



Download Netvue App from App Store or Google Play. Follow the in-app instruction to complete the entire set up process.

Mount Your Orb Pro

You can choose to install it against the wall, under the ceiling, or directly on the desktop.

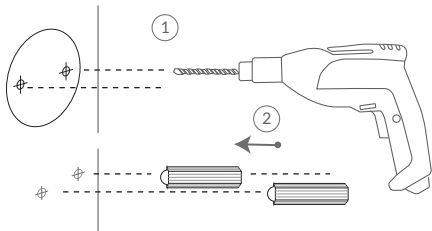

1. Use the provided drilling template to mark the position of holes on your wall. Use drill bit (15/64", 6mm) to drill two holes, and then install anchors to hold screws.

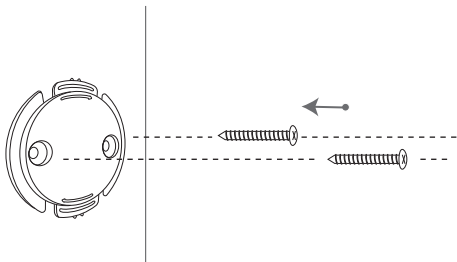

2. Install the Mounting Bracket on your wall with the Screws provided.

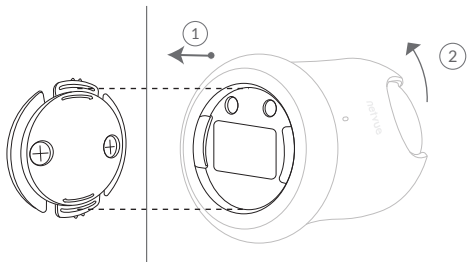

3. Put the bottom of Orb Pro against the mounting bracket in the direction as shown above, and then rotate counterclockwise to secure it.

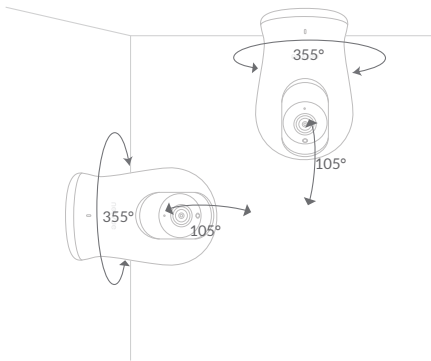

4. Now you can turn around your Orb Pro horizontally and vertically using Netvue App.

Status Light

Status Light	Description
Solid Blue	Online
Rapidly Flashing Blue	Wi-Fi Configuration Mode
Solid Red	Offline

Netvue Protect Plan

Netvue Protect Plan provides optional advanced features for those with higher security needs, and each plan supports multiple devices.



Continuous Video Recording
Event Video Recording
Human Detection

...

Visit **my.netvue.com** to learn more.

Contact Us

Feel free to contact us for additional help:

 support@netvue.com

 Netvue Forum

 in-App Chat

 @NetvueTech

 1(866)749-0567

netvue



Netvue Web Client

www.netvue.com

240 W Whitter Blvd Ste A, La Habra, CA 90631

© 2010-2020 NETVUE, INC