

FCC TEST REPORT

Test report
On Behalf of
UNESKY ELECTRONIC CO., LTD.
For
Wireless Charger
Model No.: K2, K1, K3, M1, M2, WCT-002, WCT-004, WCT-008,
WCT-022, WCT-023

FCC ID: 2A07T-K2

Prepared for : UNESKY ELECTRONIC CO., LTD.
5 F, No 63, Baotian 3 Road, Xixiang Town, Bao ' An District,
Shenzhen, China

Prepared By : Shenzhen United Testing Technology Co., Ltd.
2F, Annex Bldg, Jiahuangyuan Tech Park, #365 Baotian 1 Rd, Tiegang
Community, Xixiang Str, Bao'an District, Shenzhen, China

Date of Test: Mar. 02, 2018 ~ Mar. 09, 2018

Date of Report: Mar. 09, 2018

Report Number: UNIA2018031301-E

TEST RESULT CERTIFICATION

Applicant's name : UNESKY ELECTRONIC CO., LTD.
Address : 5 F, No 63, Baotian 3 Road, Xixiang Town, Bao ' An District,
Shenzhen, China
Manufacturer's Name..... : UNESKY ELECTRONIC CO., LTD.
Address : 5 F, No 63, Baotian 3 Road, Xixiang Town, Bao ' An District,
Shenzhen, China

Product description

Trade Mark:



Product name : Wireless Charger
Model and/or type reference : K2, K1, K3, M1, M2, WCT-002, WCT-004, WCT-008, WCT-022,
WCT-023
Standards : FCC Rules and Regulations Part 15 Subpart C (Section 15.209),
ANSI C63.10: 2013

This publication may be reproduced in whole or in part for non-commercial purposes as long as the **Shenzhen United Testing Technology Co., Ltd.** is acknowledged as copyright owner and source of the material. **Shenzhen United Testing Technology Co., Ltd.** takes no responsibility for and will not assume liability for damages resulting from the reader's interpretation of the reproduced material due to its placement and context.

Date of Test :
Date (s) of performance of tests : Mar. 02, 2018 ~ Mar. 09, 2018
Date of Issue..... : Mar. 09, 2018
Test Result..... : **Pass**

Prepared by:



Kahn yang/Editor

Reviewer:

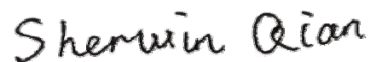

Sherwin Qian/Supervisor

Approved & Authorized Signer:



Liuze/Manager

Table of Contents	Page
1 . TEST SUMMARY	4
1.1 TEST PROCEDURES AND RESULTS	4
1.2 TEST FACILITY	4
1.3 MEASUREMENT UNCERTAINTY	4
2. GENERAL INFORMATION	5
2.1 General Description of EUT	5
2.2. Carrier Frequency of Channels	6
2.3 Operation of EUT during testing	6
2.4 Description of Test Setup	6
2.5 Measurement Instruments List	7
3. CONDUCTED EMISSION TEST	8
3.1 Block Diagram of Test Setup	8
3.2 Conducted Power Line Emission Limit	8
3.3 Test Procedure	8
3.4 Test Result	8
4. Occupied Bandwidth	11
4.1 Block Diagram of Test Setup	11
4.2 Rules and specifications	11
4.3 Test Procedure	11
4.4 Test Result	11
5. RADIATED EMISSIONS	13
5.1 Block Diagram of Test Setup	13
5.2 Rules and specifications	14
5.3 Test Procedure	15
5.4 Test Result	15
6 ANTENNA REQUIREMENT	18
7. PHOTOGRAPH OF TEST	19
7.1 Radiated Emission	19
7.2 Conducted Emission	20
7.3 External photos	21
7.4 Internal photos	24

1. TEST SUMMARY

1.1 TEST PROCEDURES AND RESULTS

DESCRIPTION OF TEST	RESULT
CONDUCTED EMISSIONS TEST	COMPLIANT
RADIATED EMISSION TEST	COMPLIANT
BAND EDGE	COMPLIANT
OCCUPIED BANDWIDTH MEASUREMENT	COMPLIANT
ANTENNA REQUIREMENT	COMPLIANT

1.2 TEST FACILITY

Test Firm : Shenzhen United Testing Technology Co., Ltd.

Address : 2F, Annex Bldg, Jiahuangyuan Tech Park, #365 Baotian 1 Rd, Tiegang Community, Xixiang Str, Bao'an District, Shenzhen, China

1.3 MEASUREMENT UNCERTAINTY

Measurement Uncertainty	
Conducted Emission Expanded Uncertainty	= 2.23dB, k=2
Radiated emission expanded uncertainty(9kHz-30MHz)	= 3.08dB, k=2
Radiated emission expanded uncertainty(30MHz-1000MHz)	= 4.42dB, k=2
Radiated emission expanded uncertainty(Above 1GHz)	= 4.06dB, k=2

2. GENERAL INFORMATION

2.1 General Description of EUT

Equipment	:	Wireless Charger
Model No.	:	K2
Series Model	:	K1, K3, M1, M2, WCT-002, WCT-004, WCT-008, WCT-022, WCT-023
FCC ID	:	2A07T-K2
Model Difference	:	All model's the function, software and electric circuit are the same, only with a product color and model named different. Test sample model: K2.
Modulation Type	:	ASK
Antenna Type	:	Coil Antenna
Antenna Gain	:	1.0dBi
Operation frequency	:	125KHz
Number of Channels	:	1
Data Rate	:	/
Power Source :	:	DC voltage
Power Rating :	:	Input voltage: DC5V 2A From adapter Output voltage: DC5V
Adapter Model :	:	Manufacturer: SAIERKANG M/N: HW-059200CHQ Input: 100-240V~50/60Hz 0.5A Output: DC 5V, 2000mA

2.2. Carrier Frequency of Channels

Operation Frequency each of channel	
Channel	Frequency
1	125KHz

2.3 Operation of EUT during testing

Operating Mode

The mode is used: Transmitting mode

2.4 Description of Test Setup

Operation of EUT during testing

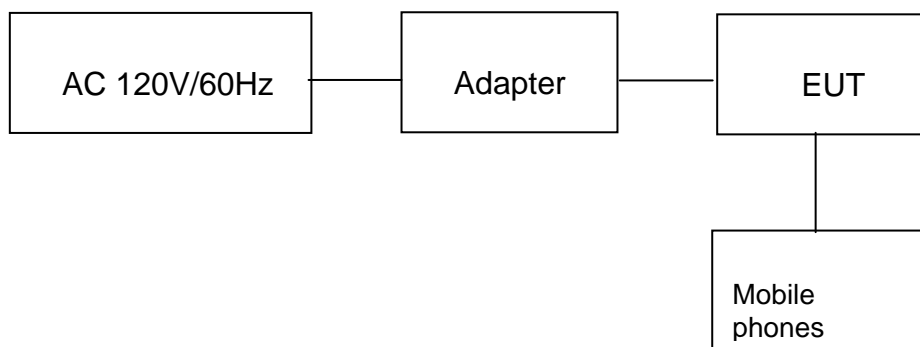

Setup:Transmission mode

2.5 Measurement Instruments List

Item	Equipment	Manufacturer	Model No.	Serial No.	Cal Date	Due Date
1.	EMI Receiver	Rohde & Schwarz	ESCI	100627	Feb. 01, 2018	Jan. 01, 2019
2.	LISN	SchwarzBeck	NSLK 8126	8126377	Feb. 01, 2018	Jan. 01, 2019
3.	RF Switching Unit	Compliance Direction	RSU-M2	38303	Feb. 01, 2018	Jan. 01, 2019
4.	EMI Test Software ES-K1	Rohde & Schwarz	N/A	N/A	N/A	N/A
5.	EMI Test Receiver	Rohde & Schwarz	ESCI	100627	Feb. 01, 2018	Jan. 01, 2019
6.	Trilog Broadband Antenna	Schwarzbeck	VULB9163	VULB 9163-289	Feb. 01, 2018	Jan. 01, 2019
7.	Pre-amplifier	Compliance Direction	PAP-0203	22008	Feb. 01, 2018	Jan. 01, 2019
8.	EMI Test Software EZ-EMC	SHURPLE	N/A	N/A	N/A	N/A
9.	EMI Receiver	Rohde & Schwarz	ESCI	100627	Feb. 01, 2018	Jan. 01, 2019
10.	LISN	SchwarzBeck	NSLK 8126	8126377	Feb. 01, 2018	Jan. 01, 2019
11.	RF Switching Unit	Compliance Direction	RSU-M2	38303	Feb. 01, 2018	Jan. 01, 2019
12.	EMI Test Software ES-K1	Rohde & Schwarz	N/A	N/A	N/A	N/A
13.	EMI Receiver	Rohde & Schwarz	ESCI	100627	Feb. 01, 2018	Jan. 01, 2019
14.	EMI Receiver	Rohde & Schwarz	ESCI	100627	Feb. 01, 2018	Jan. 01, 2019
15.	LISN	SchwarzBeck	NSLK 8126	8126377	Feb. 01, 2018	Jan. 01, 2019
16.	RF Switching Unit	Compliance Direction	RSU-M2	38303	Feb. 01, 2018	Jan. 01, 2019
17.	EMI Test Software ES-K1	Rohde & Schwarz	N/A	N/A	N/A	N/A
18.	Power Meter	R&S	NRVD	SEL0069	Feb. 01, 2018	Jan. 01, 2019
19.	Power Sensor	R&S	URV5-Z2	SEL0071	Feb. 01, 2018	Jan. 01, 2019
20.	Power Sensor	R&S	URV5-Z2	SEL0072	Feb. 01, 2018	Jan. 01, 2019
21.	Software EMC32	R&S	EMC32-S	SEL0082	N/A	N/A
22.	Log-periodic Antenna	Amplifier Reasearch	APT1.580	SEL0073	Feb. 01, 2018	Jan. 01, 2019
23.	Loop Antenna	Schwarz beck	FMZB 1516	9773	Feb. 01, 2018	Jan. 01, 2019
24.	Broadband Antenna	Schwarz beck	VULB9163	9163-333	Feb. 01, 2018	Jan. 01, 2019
25.	Horn Antenna	ETS	3117	00086197	Feb. 01, 2018	Jan. 01, 2019
26.	Horn Antenna	Schwarzbeck	BBHA9170	BBHA91705 82	Feb. 01, 2018	Jan. 01, 2019
27.	Antenna Tripod	Amplifier Reasearch	TP1000A	SEL0074	Feb. 01, 2018	Jan. 01, 2019
28.	High Gain Horn Antenna	Amplifier Reasearch	AT4002A	SEL0075	Feb. 01, 2018	Jan. 01, 2019
29.	Spectrum analyzer	Agilent	N9020A	MY49911004 8	Feb. 01, 2018	Jan. 01, 2019
30.	Spectrum analyzer	Agilent	E4407B	MY46184326	Feb. 01, 2018	Jan. 01, 2019
31.	Spectrum analyzer	R&S	FSP30	836079/035	Feb. 01, 2018	Jan. 01, 2019

3. CONDUCTED EMISSION TEST

3.1 Block Diagram of Test Setup

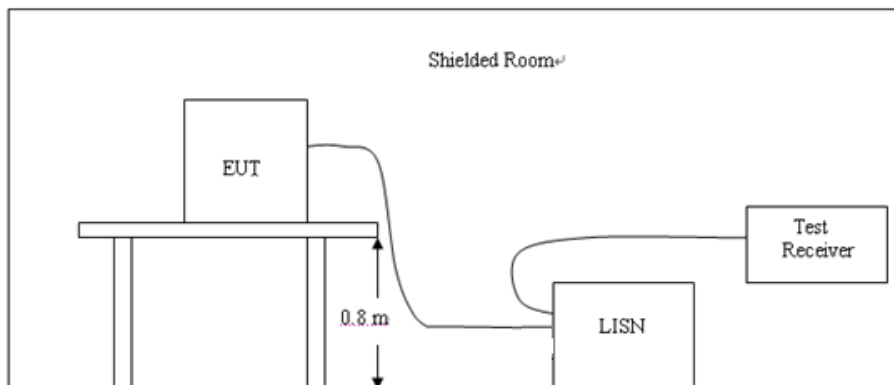

3.2 Conducted Power Line Emission Limit

For unintentional device, according to § 15.207 Line Conducted Emission Limits is as following

Frequency (MHz)	Maximum RF Line Voltage (dBµV)			
	CLASS A		CLASS B	
	Q.P.	Ave.	Q.P.	Ave.
0.15 - 0.50	79	66	66-56*	56-46*
0.50 - 5.00	73	60	56	46
5.00 - 30.0	73	60	60	50

* Decreasing linearly with the logarithm of the frequency

For intentional device, according to §15.207 Line Conducted Emission Limit is same as above table.

3.3 Test Procedure

- 1, The equipment was set up as per the test configuration to simulate typical actual usage per the user's manual. The EUT is a tabletop system, a wooden table with a height of 0.8 meters is used and is placed on the ground plane as per ANSI C63.10.
- 2, Support equipment, if needed, was placed as per ANSI C63.10.
- 3, All I/O cables were positioned to simulate typical actual usage as per ANSI C63.10.
- 4, If a EUT received DC power from the USB Port of Notebook PC, the PC's adapter received AC120V/60Hz power through a Line Impedance Stabilization Network (LISN) which supplied power source and was grounded to the ground plane.
- 5, All support equipments received AC power from a second LISN, if any.
- 6, The EUT test program was started. Emissions were measured on each current carrying line of the EUT using a spectrum Analyzer / Receiver connected to the LISN powering the EUT. The LISN has two monitoring points: Line 1 (Hot Side) and Line 2 (Neutral Side). Two scans were taken: one with Line 1 connected to Analyzer / Receiver and Line 2 connected to a 50 ohm load; the second scan had Line 1 connected to a 50 ohm load and Line 2 connected to the Analyzer / Receiver.
- 7, Analyzer / Receiver scanned from 150 KHz to 30MHz for emissions in each of the test modes

3.4 Test Result

PASS

Test Specification: Line

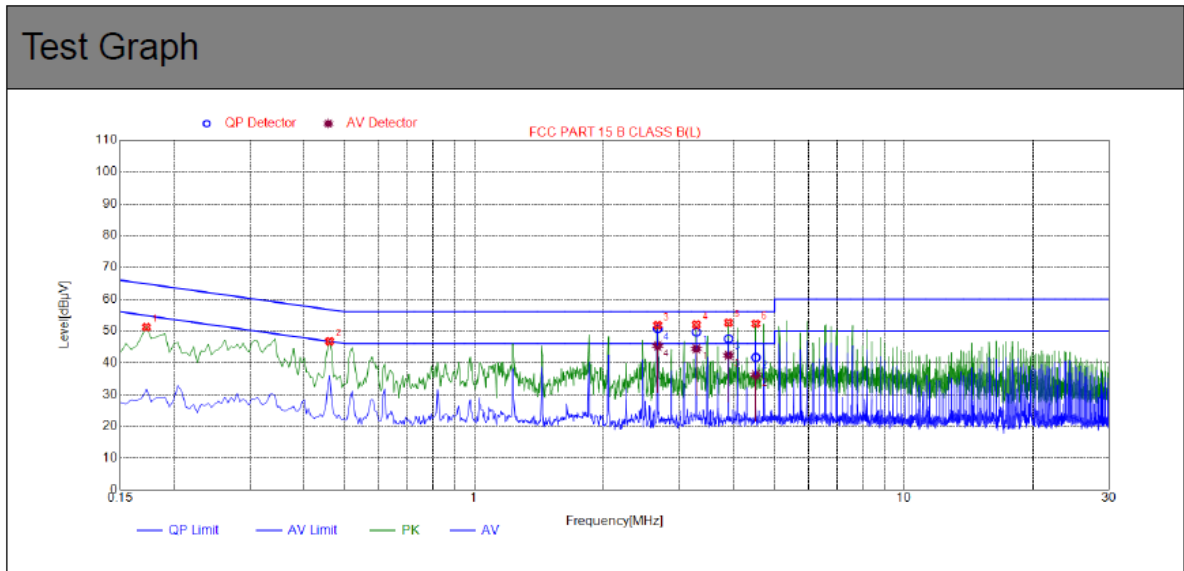

Suspected List

NO.	Freq. [MHz]	Level [dBµV]	Factor [dB]	Limit [dBµV]	Margin [dB]	Detector
1	0.1725	51.25	10.04	64.85	13.60	PK
2	0.4605	46.73	10.04	56.68	9.95	PK
3	2.6700	51.84	10.21	56.00	4.16	PK
4	3.2865	51.98	10.24	56.00	4.02	PK
5	3.9030	52.63	10.25	56.00	3.37	PK
6	4.5195	52.27	10.25	56.00	3.73	PK

Final Data List

NO.	Freq. [MHz]	Factor [dB]	QP Value [dBµV]	QP Limit [dBµV]	QP Margin [dB]	AV Value [dBµV]	AV Limit [dBµV]	AV Margin [dB]
1	3.2867	10.24	49.69	56.00	6.31	44.39	46.00	1.61
2	4.5208	10.25	41.71	56.00	14.29	36.16	46.00	9.84
3	3.9041	10.25	47.55	56.00	8.45	42.36	46.00	3.64

Test Specification: Neutral

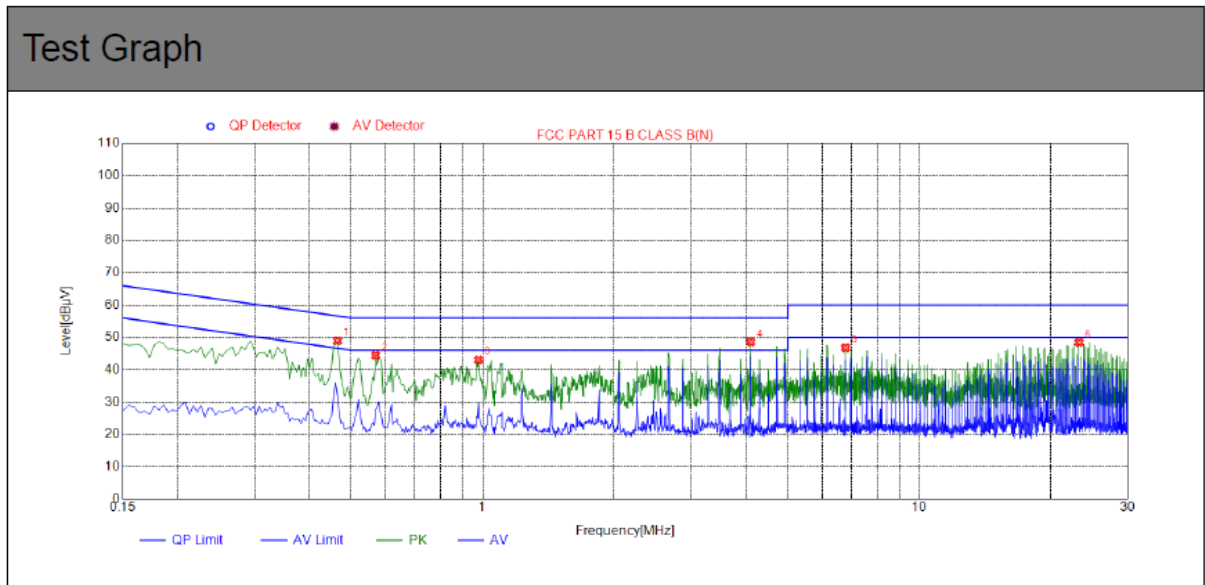

Suspected List

NO.	Freq. [MHz]	Level [dBμV]	Factor [dB]	Limit [dBμV]	Margin [dB]	Detector
1	0.4650	48.94	10.04	56.60	7.66	PK
2	0.5685	44.45	10.05	56.00	11.55	PK
3	0.9780	43.07	10.06	56.00	12.93	PK
4	4.1100	48.57	10.25	56.00	7.43	PK
5	6.7785	46.77	10.21	60.00	13.23	PK
6	23.2170	48.43	10.20	60.00	11.57	PK

4. Occupied Bandwidth

4.1 Block Diagram of Test Setup

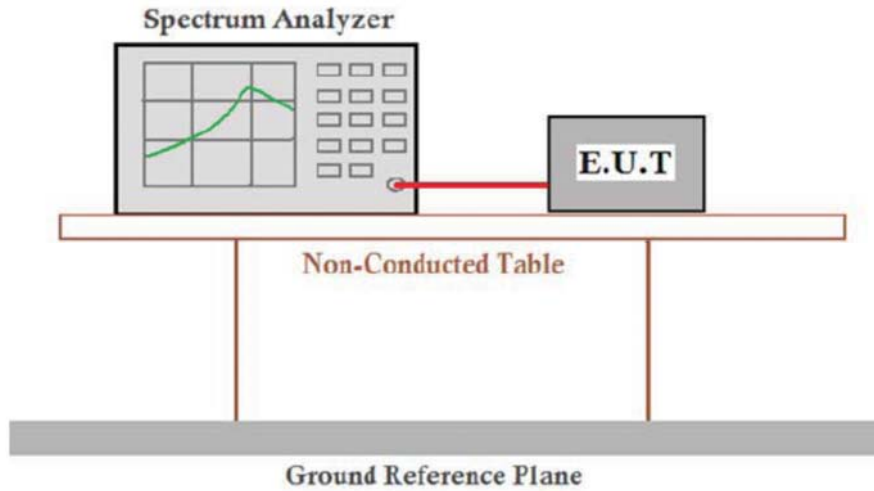

4.2 Rules and specifications

CFR 47 Part 15.215(c)

ANSI C63.10-2013

4.3 Test Procedure

Intentional radiators operating under the alternative provisions to the general emission limits, as contained in §§15.217 through 15.257 and in subpart E of this part, must be designed to ensure that 20dB bandwidth of the emission, or whatever bandwidth may otherwise be specified in the specific rule section under which the equip compliance with the 20dB attenuation specification may base on measurement at the intentional radiator's antenna output terminal unless the intentional radiator uses a permanently attached antenna, in which case compliance shall be demonstrated by measuring the radiated emissions.

4.4 Test Result

PASS

Mode	Freq (KHz)	20dB Bandwidth (KHz)	Limit (kHz)	Conclusion
Tx Mode	125	2.837	/	PASS

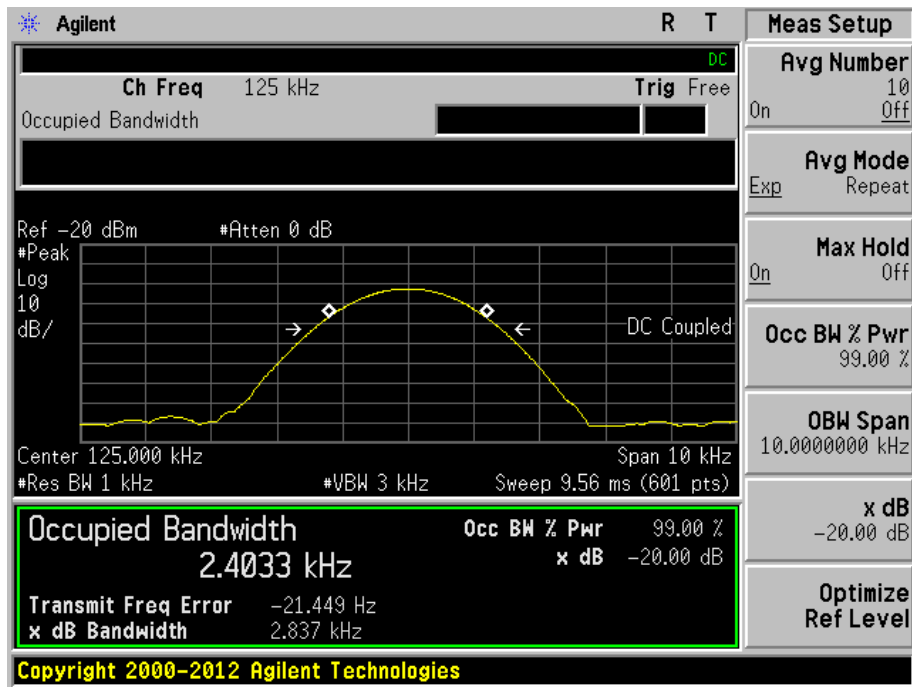

5. RADIA TED EMISSIONS

5.1 Block Diagram of Test Setup

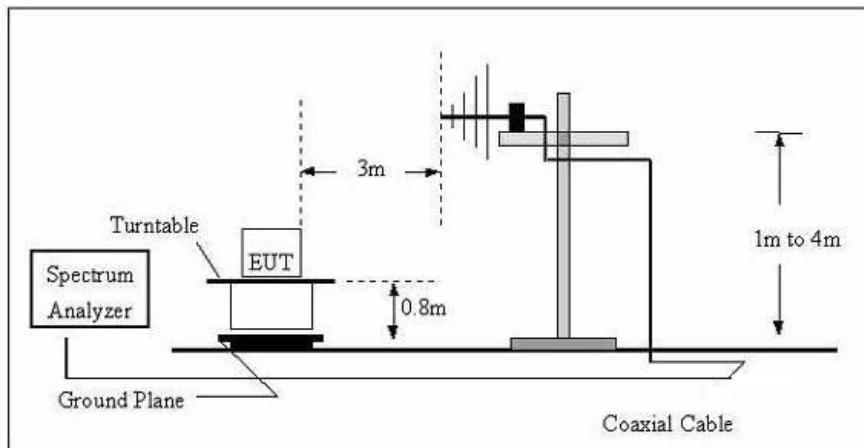
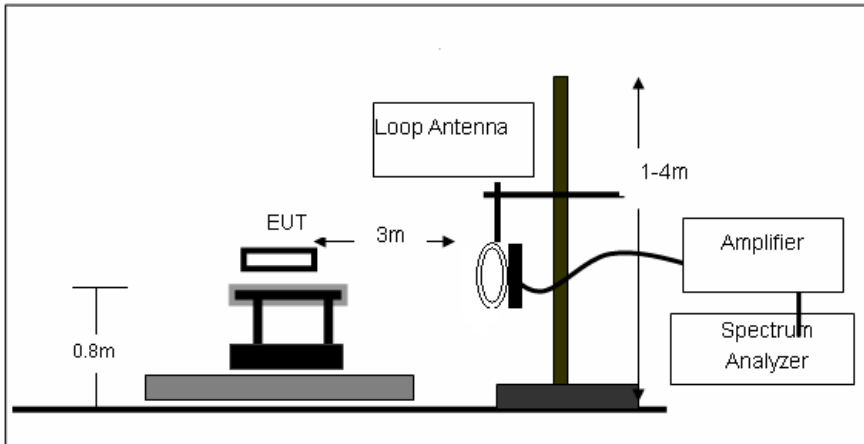

5.2 Rules and specifications

CFR 47 Part 15, section 15.205

Only spurious emissions are permitted in any of the frequency bands listed the tables in these sections.

MHz	MHz	MHz	GHz
0.090-0.110	16.42-16.423	399.9-410	4.5-5.15
1\ 0.495-0.505	16.69475-16.69525	608-614	5.35-5.46
2.1735-2.1905	16.80425-16.80475	960-1240	7.25-7.75
4.125-4.128	25.5-25.67	1300-1427	8.025-8.5
4.17725-4.17775	37.5-38.25	1435-1626.5	9.0-9.2
4.20725-4.20775	73-74.6	1645.5-1646.5	9.3-9.5
6.215-6.218	74.8-75.2	1660-1710	10.6-12.7
6.26775-6.26825	108-121.94	1718.8-1722.2	13.25-13.4
6.31175-6.31225	123-138	2200-2300	14.47-14.5
8.291-8.294	149.9-150.05	2310-2390	15.35-16.2
8.362-8.366	156.52475-156.52525	2483.5-2500	17.7-21.4
8.37625-8.38675	156.7-156.9	2690-2900	22.01-23.12
8.41425-8.41475	162.0125-167.17	3260-3267	23.6-24.0
12.29-12.293	167.72-173.2	3332-3339	31.2-31.8
12.51975-12.52025	240-285	3345.8-3358	36.43-36.5
12.57675-12.57725	322-335.4	3600-4400	(2)
13.36-13.41			

CFR 47 Part 15, section 15.209

The emissions from an intentional radiator shall not exceed the limits in the tables in these sections using an average detector

Frequency (MHz)	Field strength (microvolts/meter)	Measurement distance (meters)
0.009–0.490	2400/F(kHz)	300
0.490–1.705	24000/F(kHz)	30
1.705–30.0	30	30
30–88	100**	3
88–216	150**	3
216–960	200**	3
Above 960	500	3

Limit calculation and transfer to 3m distance as showed in the following table:

Frequency (MHz)	Limit (dBuV/m)	Distance (m)
0.009-0.490	$20\log(2400/F(KHz))+40\log(300/3)$	3
0.490-1.705	$20\log(2400/F(KHz))+40\log(300/3)$	3
1.705-30.0	69.5	3
30-88	40.0	3
88-216	43.5	3
216-960	46.0	3
Above 960	54.0	3

CFR 47 Part 15, section 15.35

When average radiated emission measurements are specified, the limit on the peak level of the radio Frequency emission is 20dB above the maximum permitted average emission limit.

Transmitter Spurious Emissions 9KHz-30MHz			
	9-150KHz	150-490KHz	490KHz-30MHz
Resolution Bandwidth	200Hz	9KHz	9KHz
Video Bandwidth	2KHz	100KHz	100KHz
Detector	Peak	Peak	Peak
Trace Mode	Max Hold	Max Hold	Max Hold
Sweep Time	Auto	Auto	Auto

5.3 Test Procedure

Measurement distance 3m

For the measurement range up to 30MHz in the following plots the field strength result from 3m Distance measurement are extrapolated to 300m and 30m distance respectively, by 40dB/decade, According to part 15.31(f)(2), per antenna factor scaling.

Measurements below 1000MHz are performed with a peak detector and compared to average limits, Measurements with an average detector are not required.

Note:

For battery operated equipment, the equipment tests shall be performed using a new battery.

5.4 Test Result

PASS

For 9KHz-30MHz

Freq. (MHz)	Position H/V	Detector Mode (PK/QP)	Reading (dBuV)	Factor (dB)	Actual FS (dBuV/m)	Limits 3m (dBuV/m)	Margin (dBuV/m)
0.110	H	Peak	25.91	24.8	50.71	126.77	76.06
0.125	H	Peak	46.28	24.8	71.08	125.67	54.59
0.486	H	Peak	24.16	25.03	49.19	113.71	64.52
0.500	H	Peak	26.82	25.03	51.85	113.62	61.77
N/A							
Freq. (MHz)	Position H/V	Detector Mode (PK/QP)	Reading (dBuV)	Factor (dB)	Actual FS (dBuV/m)	Limits 3m (dBuV/m)	Margin (dBuV/m)
0.110	V	Peak	24.63	24.8	49.43	126.77	77.34
0.125	V	Peak	44.14	24.8	68.94	125.67	56.73
0.494	V	Peak	22.88	25.03	47.91	113.71	65.8
0.500	V	Peak	25.32	25.03	50.35	113.62	63.27
N/A							

For 30MHz-1GHz

Antenna polarity: H

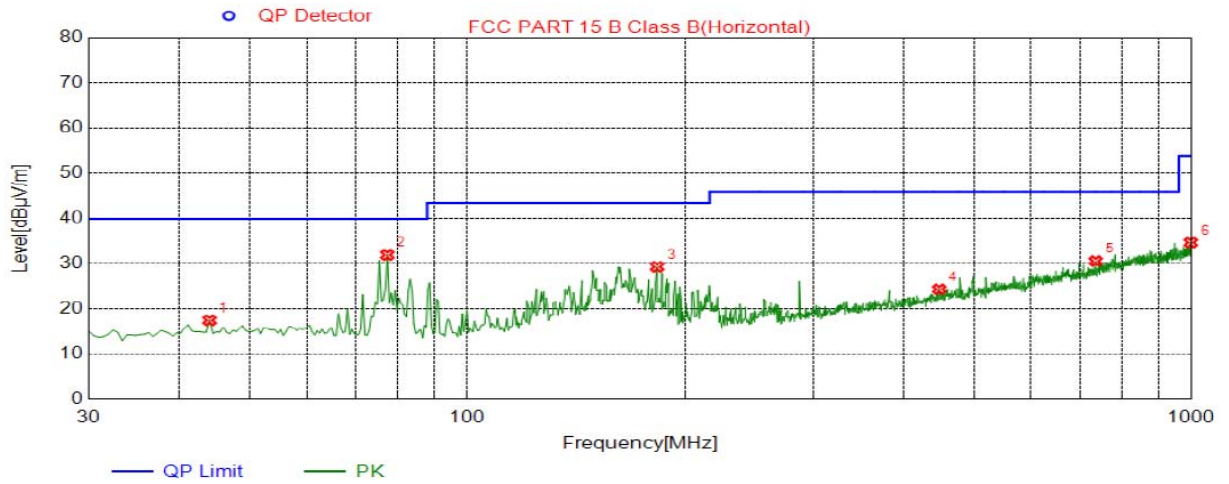

Suspected List

NO.	Freq. [MHz]	Level [dBµV/m]	Factor [dB]	Limit [dBµV/m]	Margin [dB]	Height [cm]	Angle [°]	Polarity
1	44.0650	17.55	-16.59	40.00	22.45	100	228	Horizontal
2	77.5300	32.01	-18.90	40.00	7.99	100	248	Horizontal
3	182.7750	29.39	-13.50	43.50	14.11	100	300	Horizontal
4	448.0700	24.42	-9.13	46.00	21.58	100	261	Horizontal
5	736.6450	30.66	-3.56	46.00	15.34	100	182	Horizontal
6	996.6050	34.76	0.32	54.00	19.24	100	208	Horizontal

Antenna polarity: V

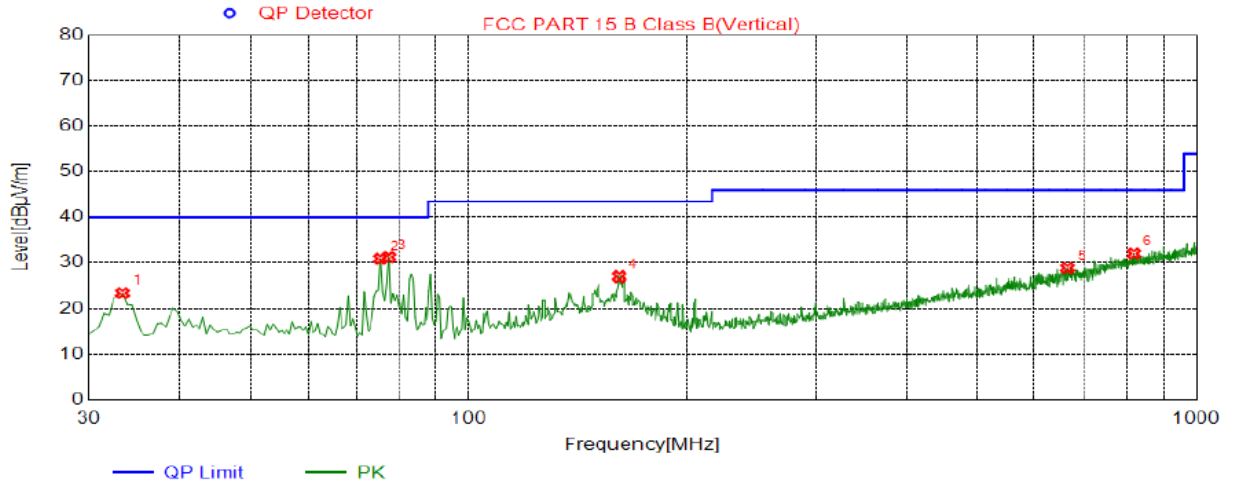

Suspected List

NO.	Freq. [MHz]	Level [dBµV/m]	Factor [dB]	Limit [dBµV/m]	Margin [dB]	Height [cm]	Angle [°]	Polarity
1	33.3950	23.63	-17.35	40.00	16.37	100	5	Vertical
2	75.5900	30.91	-18.61	40.00	9.09	100	159	Vertical
3	77.5300	31.25	-18.90	40.00	8.75	100	159	Vertical
4	160.9500	27.06	-9.29	43.50	16.44	100	87	Vertical
5	663.8950	28.84	-4.56	46.00	17.16	100	188	Vertical
6	818.1250	32.03	-1.85	46.00	13.97	100	97	Vertical

6 ANTENNA REQUIREMENT

Standard Applicable

For intentional device, according to FCC 47 CFR Section 15.203, an intentional radiator shall be designed to ensure that no antenna other than that furnished by the responsible party shall be used with the device.

Refer to statement below for compliance.

The manufacturer may design the unit so that the user can replace a broken antenna, but the use of a standard antenna jack or electrical connector is prohibited. Further, this requirement does not apply to intentional radiators that must be professionally installed.

Antenna Connected Construction

The antenna used in this product is a Coil Antenna, The directional gains of antenna used for transmitting is 1dBi.

ANTENNA

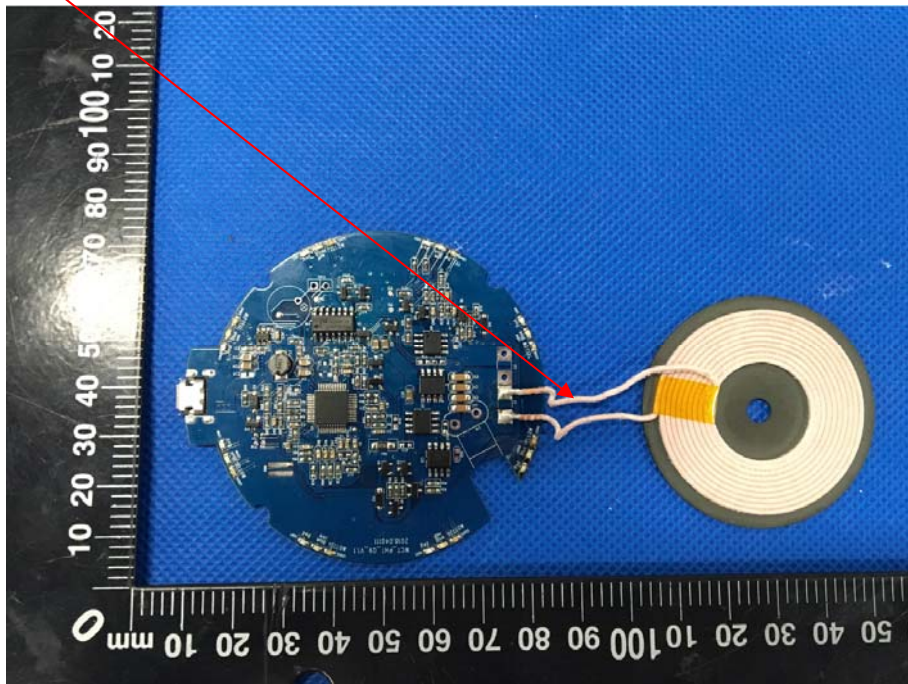

7. PHOTOGRAPH OF TEST

7.1 Radiated Emission

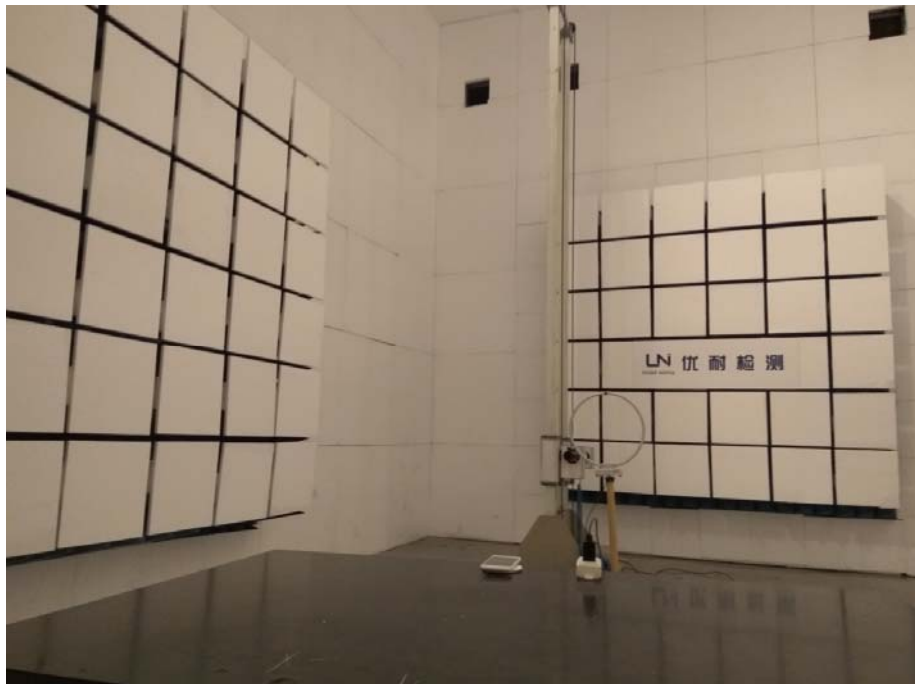
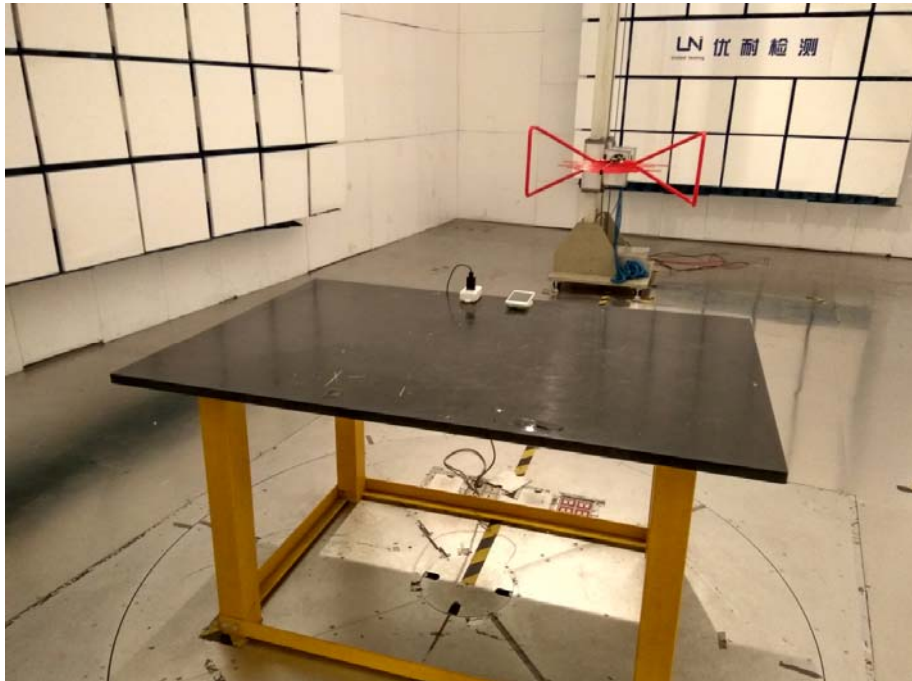

7.2 Conducted Emission



7.3 External photos

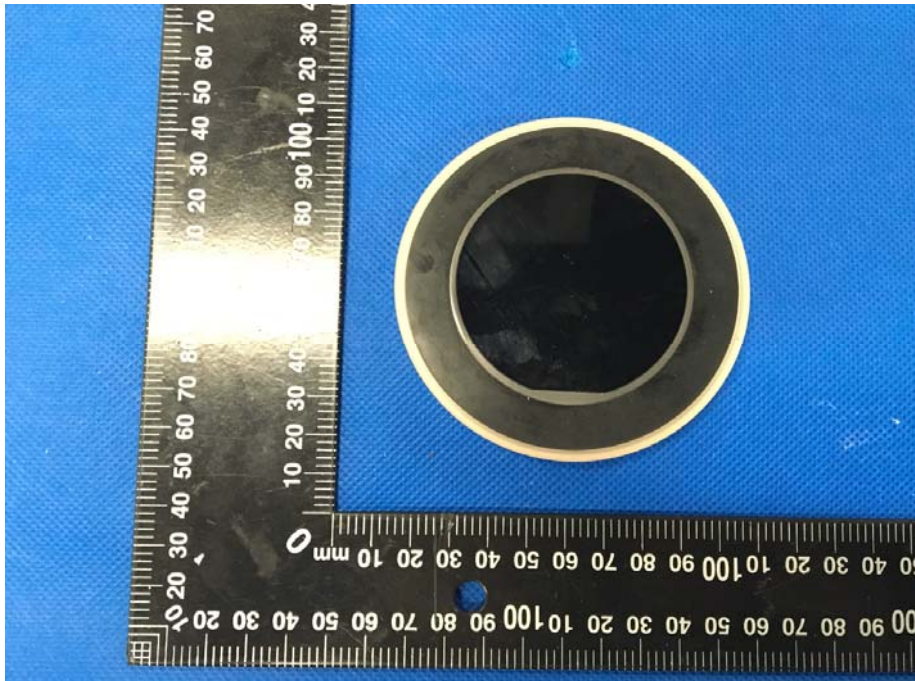
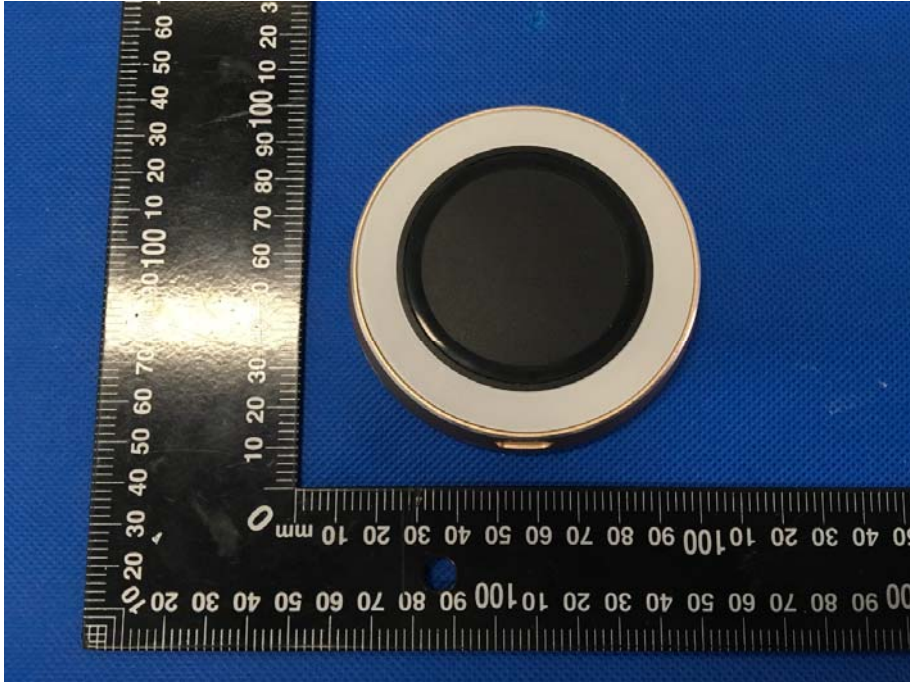

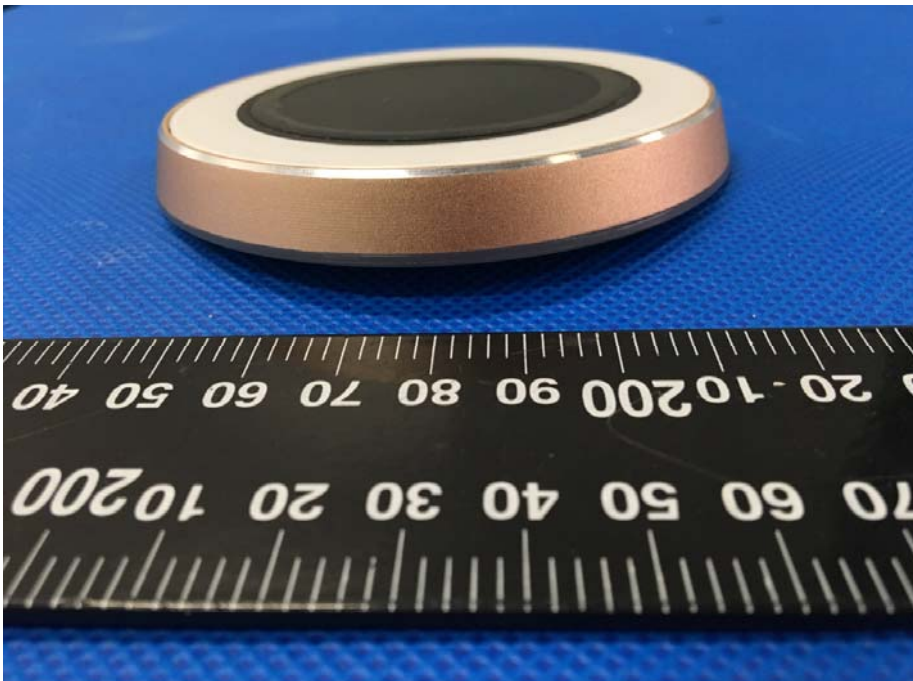
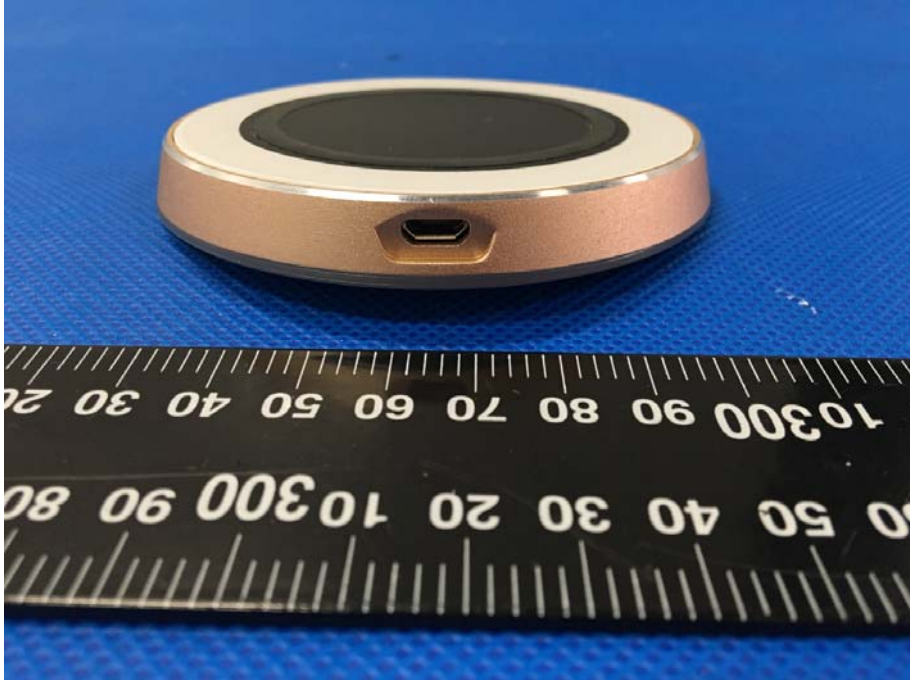

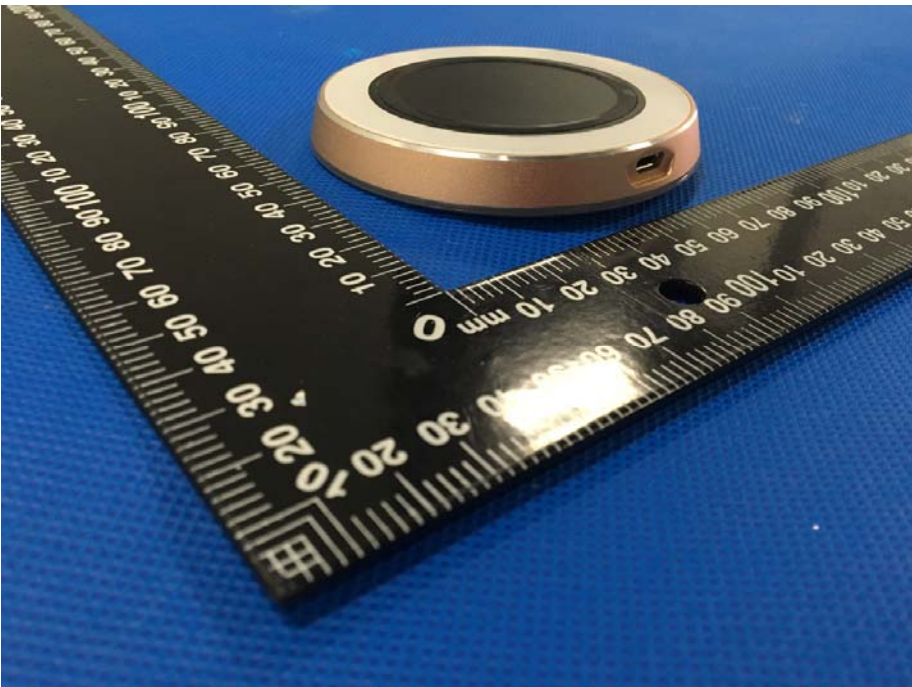
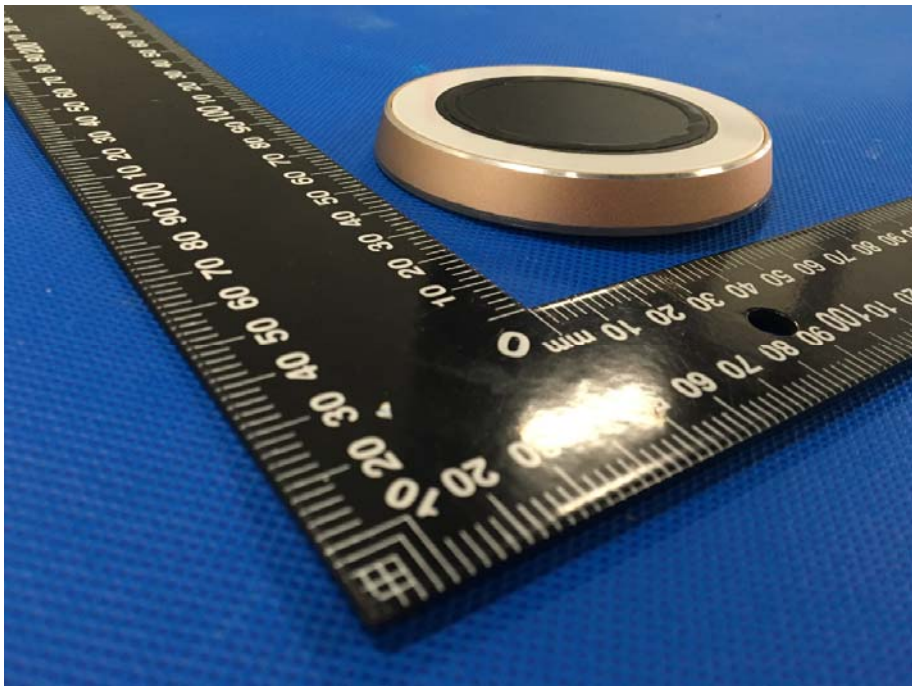

7.4 Internal photos

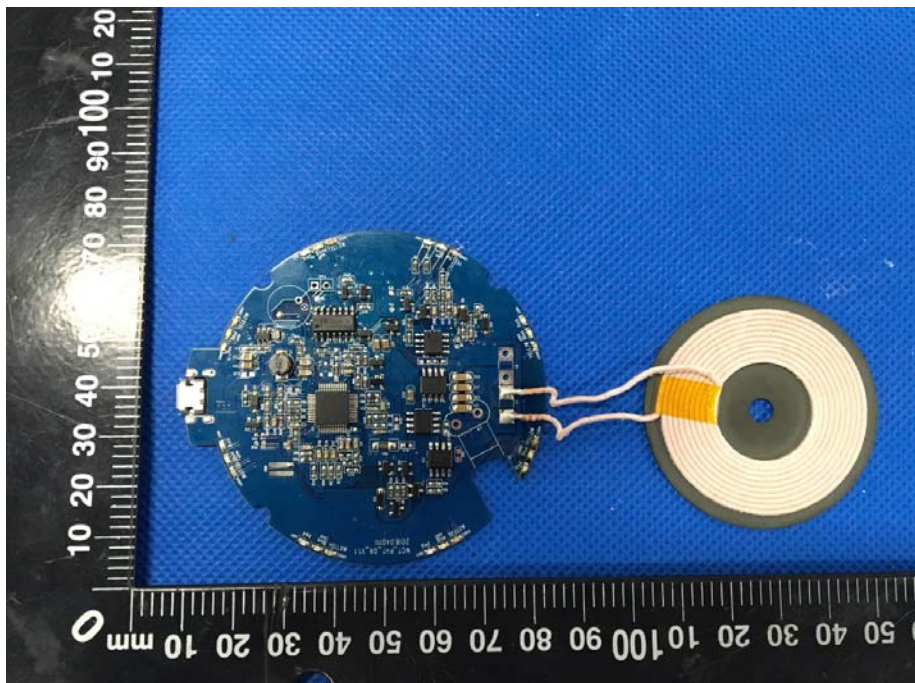
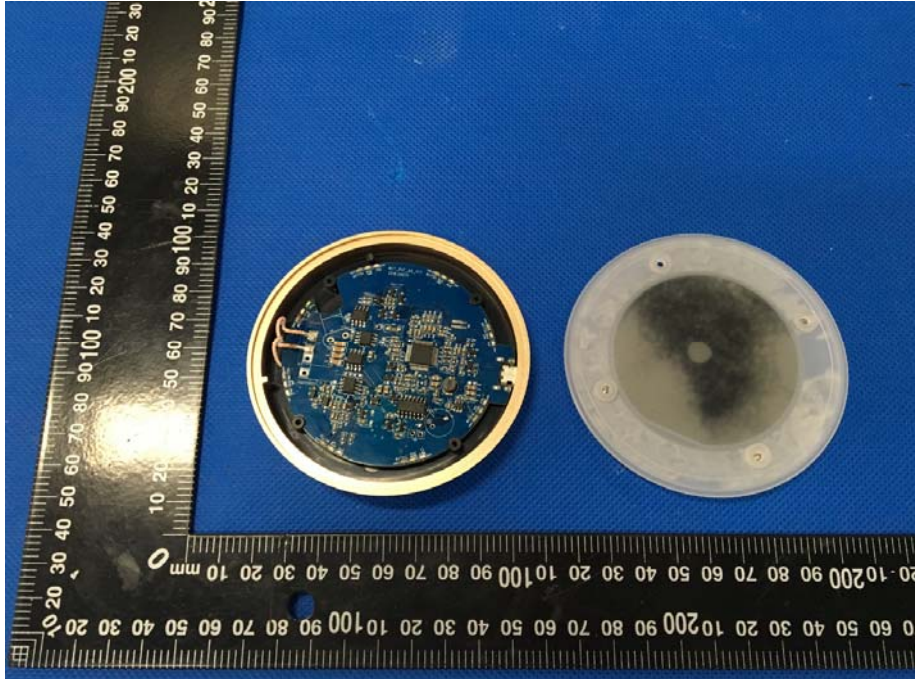

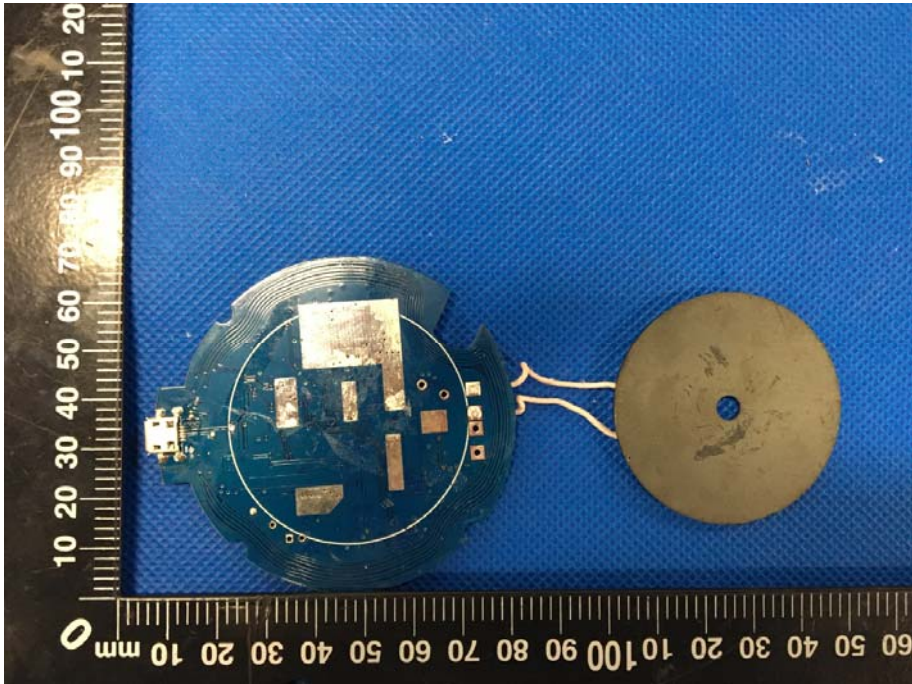

End of Report