



FCC PART 27
FCC PART 22H, PART 24E
TEST REPORT

For

Epik One America Corporation

170 Ocean Lane Dr. #705, Key Biscayne, FL 33149, United States

FCC ID: 2AO6ZX500

Report Type: Original Report	Product Type: Smartphone
Report Number:	RSZ180410004-00C
Report Date:	2018-05-07
Reviewed By:	Rocky Kang RF Engineer <i>Rocky Kang</i>
Prepared By:	Bay Area Compliance Laboratories Corp. (Shenzhen) 6/F., West Wing, Third Phase of Wanli Industrial Building, Shihua Road, Futian Free Trade Zone, Shenzhen, Guangdong, China Tel: +86-755-33320018 Fax: +86-755-33320008 www.baclcorp.com.cn

This report must not be used by the customer to claim product certification, approval, or endorsement by A2LA* or any agency of the Federal Government. * This report may contain data that are not covered by the A2LA accreditation and are marked with an asterisk “*”.

TABLE OF CONTENTS

GENERAL INFORMATION.....	3
PRODUCT DESCRIPTION FOR EQUIPMENT UNDER TEST (EUT)	3
OBJECTIVE	3
RELATED SUBMITTAL(S)/GRANT(S).....	3
TEST METHODOLOGY	3
MEASUREMENT UNCERTAINTY	4
TEST FACILITY	4
SYSTEM TEST CONFIGURATION.....	5
DESCRIPTION OF TEST CONFIGURATION	5
EQUIPMENT MODIFICATIONS	5
SUPPORT EQUIPMENT LIST AND DETAILS	5
BLOCK DIAGRAM OF TEST SETUP	5
SUMMARY OF TEST RESULTS.....	6
TEST EQUIPMENT LIST	7
FCC §1.1307(B) & §2.1093 - RF EXPOSURE INFORMATION.....	9
APPLICABLE STANDARD	9
TEST RESULT	9
FCC §2.1047 - MODULATION CHARACTERISTIC	10
FCC § 2.1046, § 22.913 (A) & § 24.232 (C); §27.50(H) (D) - RF OUTPUT POWER	11
APPLICABLE STANDARD	11
TEST PROCEDURE	11
TEST DATA	11
FCC §2.1049, §22.917, §22.905 & §24.238 & §27.53 - OCCUPIED BANDWIDTH.....	35
APPLICABLE STANDARD	35
TEST PROCEDURE	35
TEST DATA	35
FCC §2.1051, §22.917(A) & §24.238(A); §27.53 (H) (M) - SPURIOUS EMISSIONS AT ANTENNA TERMINALS.....	66
APPLICABLE STANDARD	66
TEST PROCEDURE	66
TEST DATA	66
FCC § 2.1053; § 22.917 (A);§ 24.238 (A); §27.53 (H)(M) SPURIOUS RADIATED EMISSIONS.....	100
APPLICABLE STANDARD	100
TEST PROCEDURE	100
TEST DATA	100
FCC § 22.917 (A);§ 24.238 (A); §27.53 (H)(M) - BAND EDGES	104
APPLICABLE STANDARD	104
TEST PROCEDURE	104
TEST DATA	104
FCC § 2.1055; § 22.355; § 24.235; §27.54 - FREQUENCY STABILITY	155
APPLICABLE STANDARD	155
TEST PROCEDURE	155
TEST DATA	156

GENERAL INFORMATION

Product Description for Equipment under Test (EUT)

The *Epik One America Corporation's* product, model number: *X500 (FCC ID: 2A06ZX500)* or the "EUT" in this report was a *Smartphone*, which was measured approximately: 140.3mm (L) × 66.1mm (W) × 9.8mm (H), rated with input voltage: DC 3.7V from rechargeable Li-ion battery or DC 5.0V from adapter.

Adapter Information:

Model: ZHY-QU050100S

Input: AC 100-240V, 50/60Hz, 0.2A

Output: DC 5.0V, 1 A

**All measurement and test data in this report was gathered from production sample serial number: 1800494 (Assigned by BACL, Shenzhen). The EUT supplied by the applicant were received on 2018-04-10.*

Objective

This test report is prepared on behalf of *Epik One America Corporation* in accordance with Part 2-Subpart J, Part 22-Subpart H and Part 24-Subpart E and Subpart 27 of the Federal Communication Commissions rules.

The objective is to determine the compliance of the EUT with FCC rules for output power, modulation characteristic, occupied bandwidth, and spurious emission at antenna terminal, spurious radiated emission, frequency stability and band edge.

Related Submittal(s)/Grant(s)

FCC Part 15.247 DSS and Part 15.247 DTS submissions with FCC ID: 2A06ZX500.

Test Methodology

All tests and measurements indicated in this document were performed in accordance with the Code of Federal Regulations Title 47 Part 2-Subpart J as well as the following parts:

Part 22 Subpart H - Public Mobile Services

Part 24 Subpart E - Personal Communication Services

Part 27 – Miscellaneous wireless communications services

All emissions measurement was performed at Bay Area Compliance Laboratories Corp. (Shenzhen). The radiated testing was performed at an antenna-to-EUT distance of 3 meters.

Measurement Uncertainty

Parameter		Uncertainty
Occupied Channel Bandwidth		±5%
RF output power, conducted		±1.5dB
Unwanted Emission, conducted		±1.5dB
Emissions, radiated	Below 1GHz	±4.70dB
	Above 1GHz	±4.80dB
Temperature		±1 °C
Supply voltages		±0.4%

Test Facility

The Test site used by Bay Area Compliance Laboratories Corp. (Shenzhen) to collect test data is located on the 6/F., West Wing, Third Phase of Wanli Industrial Building, Shihua Road, Futian Free Trade Zone, Shenzhen, Guangdong, China.

The test site has been approved by the FCC under the KDB 974614 D01 and is listed in the FCC Public Access Link (PAL) database, FCC Registration No.: 342867, the FCC Designation No.: CN1221.

The test site has been registered with ISED Canada under ISED Canada Registration Number 3062B.

SYSTEM TEST CONFIGURATION

Description of Test Configuration

The EUT was configured for testing according to TIA/EIA-603-D.

The final qualification test was performed with the EUT operating at normal mode.

Equipment Modifications

No modification was made to the EUT.

Support Equipment List and Details

Manufacturer	Description	Model	Serial Number
Rohde & Schwarz	Wideband Radio Communication Tester	CMW500	1201.002K50-116218-UY
Rohde & Schwarz	Universal Radio Communication Tester	CMU200	110605

Block Diagram of Test Setup

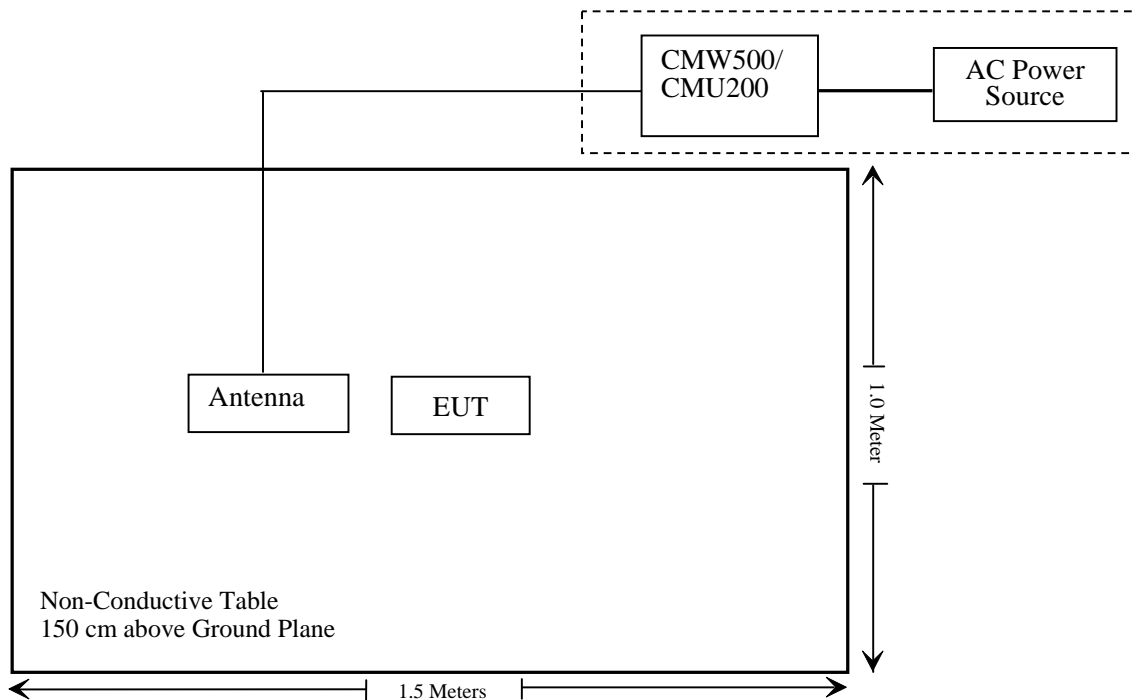

SUMMARY OF TEST RESULTS

FCC Rules	Description of Test	Result
§ 1.1307 , §2.1093	RF Exposure (SAR)	Compliance*
§2.1046; § 22.913 (a); § 24.232 (c); §27.50 (h) (d)	RF Output Power	Compliance
§ 2.1047	Modulation Characteristics	Not Applicable
§ 2.1049; § 22.905; § 22.917; § 24.238; §27.53	Occupied Bandwidth	Compliance
§ 2.1051; § 22.917 (a); § 24.238 (a); §27.53 (h)(m)	Spurious Emissions at Antenna Terminal	Compliance
§ 2.1053; § 22.917 (a); § 24.238 (a); §27.53 (h)(m)	Field Strength of Spurious Radiation	Compliance
§ 22.917 (a); § 24.238 (a); §27.53 (h)(m)	Band Edge	Compliance
§ 2.1055; § 22.355; § 24.235; §27.54;	Frequency stability	Compliance

Note: * Please refer to SAR report released by BACL, report number: RSZ180410004-20

TEST EQUIPMENT LIST

Manufacturer	Description	Model	Serial Number	Calibration Date	Calibration Due Date
Radiated Emission Test					
Sunol Sciences	Horn Antenna	DRH-118	A052604	2017-12-22	2020-12-21
Rohde & Schwarz	Signal ANALYZER	FSIQ26	8386001028	2017-04-24	2018-04-24
Sunol Sciences	Broadband Antenna	JB1	A040904-1	2017-12-22	2020-12-21
Mini	Pre-amplifier	ZVA-183-S+	5969001149	2017-05-21	2018-05-21
HP	Amplifier	HP8447E	1937A01046	2017-11-19	2018-05-21
Anritsu	Signal Generator	68369B	004114	2017-12-07	2018-12-07
Rohde & Schwarz	EMI Test Receiver	ESCI	101120	2018-01-11	2019-01-11
COM POWER	Dipole Antenna	AD-100	041000	NCR	NCR
A.H. System	Horn Antenna	SAS-200/571	135	2015-08-18	2018-08-17
UTiFLEX MICRO-C0AX	RF Cable	UFA147A-2362-100100	MFR64639 231029-003	2018-04-01	2018-10-01
Ducommun technologies	RF Cable	104PEA	218124002	2017-11-19	2018-05-21
Ducommun technologies	RF Cable	RG-214	1	2017-11-19	2018-05-21
Ducommun technologies	RF Cable	RG-214	2	2017-11-22	2018-05-22
Ducommun Technologies	Horn Antenna	ARH-4223-02	1007726-04	2017-12-29	2020-12-28
Ducommun technologies	Horn Antenna	ARH-4223-02	1007726-03	2017-12-29	2020-12-28
Ducommun technologies	Pre-amplifier	ALN-22093530-01	991373-01	2017-08-03	2018-08-03

Manufacturer	Description	Model	Serial Number	Calibration Date	Calibration Due Date
RF Conducted Test					
Rohde & Schwarz	SPECTRUM ANALYZER	FSU26	200120	2017-12-24	2018-12-24
ESPEC	Temperature & Humidity Chamber	EL-10KA	09107726	2017-12-21	2018-12-21
Long Wei	DC Power Supply	TPR-6420D	398363	NCR	NCR
Rohde & Schwarz	Wideband Radio Communication Tester	CMU200	106891	2017-12-14	2018-12-14
Rohde & Schwarz	Wideband Radio Communication Tester	CMW500	1201.002K50-146520-wh	2017-04-24	2018-04-24
Ducommun technologies	RF Cable	RG-214	3	2017-11-22	2018-05-22
WEINSCHEL	10dB Attenuator	5324	AU 3842	2017-11-22	2018-05-23
WEINSCHEL	3dB Attenuator	N/A	N/A	2017-11-22	2018-05-23
N/A	Power Splitter	N/A	N/A	2017-05-21	2018-05-21

* Statement of Traceability: Bay Area Compliance Laboratories Corp. (Shenzhen) attests that all calibrations have been performed in accordance to requirements that traceable to National Primary Standards and International System of Units (SI).

FCC §1.1307(b) & §2.1093 - RF EXPOSURE INFORMATION

Applicable Standard

FCC§1.1310 and §2.1093.

Test Result

Compliance, please refer to the SAR report: RSZ180410004-20.

FCC §2.1047 - MODULATION CHARACTERISTIC

According to FCC § 2.1047(d), Part 22H & 24E & 27 there is no specific requirement for digital modulation, therefore modulation characteristic is not presented.

FCC § 2.1046, § 22.913 (a) & § 24.232 (c); §27.50(h) (d) - RF OUTPUT POWER

Applicable Standard

According to FCC §2.1046 and §22.913 (a), the ERP of mobile transmitters and auxiliary test transmitters must not exceed 7 watts.

According to FCC §2.1046 and §24.232 (C), mobile and portable stations are limited to 2 watts EIRP and the equipment must employ a means for limiting power to the minimum necessary for successful communications.

The peak-to-average power ratio (PAPR) of the transmitter output power must not exceed 13 dB.

According to §27.50(h), Mobile stations are limited to 2.0 watts EIRP. All user stations are limited to 2.0 watts transmitter output power.

According to §27.50(d), the maximum EIRP must not exceed 1Watts (30dBm) for 1710-1755MHz.

Test Procedure

Conducted method:

The RF output of the transmitter was connected to the CMW500/CMU200 through sufficient attenuation.

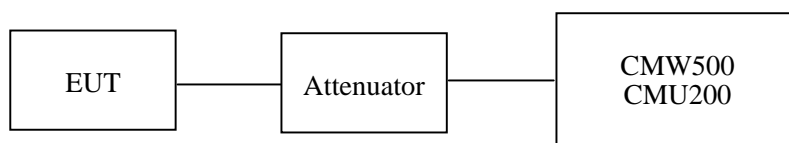

Radiated method:

TIA 603-D section 2.2.17

Test Data

Environmental Conditions

Temperature:	25 °C
Relative Humidity:	52 %
ATM Pressure:	101.0 kPa

The testing was performed by Tracy Hu on 2018-04-14.

Conducted Power

Cellular Band (Part 22H)

Mode	Channel	Frequency (MHz)	Average Output Power (dBm)	Limit (dBm)
GSM	128	824.2	31.14	38.45
	190	836.6	31.16	38.45
	251	848.8	31.24	38.45

Mode	Channel	Frequency (MHz)	Average Output Power (dBm)				Limit (dBm)
			1 slot	2 slots	3 slots	4 slots	
GPRS	128	824.2	31.02	30.24	28.32	27.20	38.45
	190	836.6	31.20	30.30	28.33	27.26	38.45
	251	848.8	31.30	30.28	28.36	27.16	38.45

Mode	Channel	Frequency (MHz)	Average Output Power (dBm)				Limit (dBm)
			1 slot	2 slots	3 slots	4 slots	
EGPRS	128	824.2	25.45	24.12	22.75	20.60	38.45
	190	836.6	25.36	24.20	22.83	20.69	38.45
	251	848.8	25.66	24.18	22.86	20.74	38.45

Mode	Test Condition	Test Mode	3GPP Sub Test	Average Output Power (dBm)		
				Low Frequency	Middle Frequency	High Frequency
WCDMA (Band V)	Normal	RMC12.2k		22.53	22.41	22.36
		HSDPA	1	21.45	21.18	21.01
			2	21.53	21.45	21.35
			3	21.65	21.66	21.50
			4	21.48	21.50	21.34
		HSUPA	1	20.82	20.96	20.83
			2	20.74	20.56	20.69
			3	20.69	20.71	20.63
			4	20.63	20.53	20.48
			5	20.82	20.73	20.63

PCS Band (Part 24E)

Mode	Channel	Frequency (MHz)	Average Output Power (dBm)	Limit (dBm)
GSM	512	1850.2	28.25	33
	661	1880.0	28.35	33
	810	1909.8	28.40	33

Mode	Channel	Frequency (MHz)	Average Output Power (dBm)				Limit (dBm)
			1 slot	2 slots	3 slots	4 slots	
GPRS	512	1850.2	27.86	26.18	24.58	23.44	33
	661	1880.0	27.74	26.19	24.61	23.50	33
	810	1909.8	27.69	26.22	24.68	23.52	33

Mode	Channel	Frequency (MHz)	Average Output Power (dBm)				Limit (dBm)
			1 slot	2 slots	3 slots	4 slots	
EGPRS	512	1850.2	24.02	23.10	21.10	20.32	33
	661	1880.0	24.12	23.16	21.15	20.35	33
	810	1909.8	24.15	23.20	21.17	20.33	33

Mode	Test Condition	Test Mode	3GPP Sub Test	Average Output Power (dBm)		
				Low Frequency	Middle Frequency	High Frequency
WCDMA (Band II)	Normal	RMC12.2k		21.71	21.61	21.70
		HSDPA	1	21.12	21.53	21.16
			2	21.63	21.54	21.58
			3	21.71	21.73	21.63
			4	21.69	21.66	21.73
		HSUPA	1	20.63	20.76	20.87
			2	20.77	20.68	20.76
			3	20.82	20.73	20.69
			4	20.69	20.66	20.52
			5	20.82	20.47	20.46

Peak-to-average ratio (PAR)

Cellular Band

Mode	Channel	PAR (dB)	Limit (dB)
GSM	Low	2.12	13
	Middle	2.32	13
	High	2.37	13

Mode	Channel	PAR (dB)	Limit (dB)
EGPRS	Low	2.63	13
	Middle	2.54	13
	High	2.67	13

Mode	Channel	PAR (dB)	Limit (dB)
RMC (BPSK)	Low	3.32	13
	Middle	3.12	13
	High	3.37	13
HSDPA (16QAM)	Low	3.32	13
	Middle	3.12	13
	High	3.32	13
HSUPA (BPSK)	Low	3.41	13
	Middle	3.12	13
	High	3.35	13

PCS Band

Mode	Channel	PAR (dB)	Limit (dB)
GSM	Low	2.01	13
	Middle	2.12	13
	High	2.08	13

Mode	Channel	PAR (dB)	Limit (dB)
EGPRS	Low	2.53	13
	Middle	2.61	13
	High	2.58	13

Mode	Channel	PAR (dB)	Limit (dB)
RMC (BPSK)	Low	3.63	13
	Middle	3.47	13
	High	3.68	13
HSDPA (16QAM)	Low	3.63	13
	Middle	3.49	13
	High	3.61	13
HSUPA (BPSK)	Low	3.62	13
	Middle	3.43	13
	High	3.62	13

**Radiated Power
GSM Mode:**

Frequency (MHz)	Receiver Reading (dBµV)	Turntable Angle Degree	Rx Antenna		Substituted			Absolute Level (dBm)	FCC Part 22H/24E	
			Height (m)	Polar (H/V)	Level (dBm)	Cable loss (dB)	Antenna Gain (dB)		Limit (dBm)	Margin (dB)
ERP for Cellular Band (Part 22H), Middle Channel										
836.6	79.80	296	2.4	H	17.8	0.7	0.0	17.10	38.45	21.35
836.6	89.88	227	1.8	V	29.4	0.7	0.0	28.70	38.45	9.75
EIRP for PCS Band (Part 24E), Middle Channel										
1880.00	86.66	180	2.2	H	16.6	1.30	9.40	24.70	33	8.3
1880.00	87.35	135	2.1	V	17.1	1.30	9.40	25.20	33	7.8

EDGE Mode:

Frequency (MHz)	Receiver Reading (dBµV)	Turntable Angle Degree	Rx Antenna		Substituted			Absolute Level (dBm)	Limit (dBm)	Margin (dB)
			Height (m)	Polar (H/V)	Level (dBm)	Cable loss (dB)	Antenna Gain (dB)			
ERP, Cellular Band (Part 22H), Middle Channel										
836.6	77.62	40	1.6	H	15.2	0.7	0.0	14.50	38.45	23.95
836.6	84.32	13	1.2	V	23.9	0.7	0.0	23.20	38.45	15.25
EIRP, PCS Band (Part 24E), Middle Channel										
1880.00	83.85	303	2.4	H	13.8	1.30	9.40	21.90	33	11.1
1880.00	84.53	51	1.4	V	14.3	1.30	9.40	22.40	33	10.6

WCDMA Mode:

Frequency (MHz)	Receiver Reading (dBµV)	Turntable Angle Degree	Rx Antenna		Substituted			Absolute Level (dBm)	FCC Part 22H/24E	
			Height (m)	Polar (H/V)	Level (dBm)	Cable loss (dB)	Antenna Gain (dB)		Limit (dBm)	Margin (dB)
ERP for WCDMA Band V (Part 22H), Middle Channel										
836.6	76.36	289	2.0	H	14.0	0.7	0.0	13.30	38.45	25.15
836.6	80.92	45	1.4	V	20.5	0.7	0.0	19.80	38.45	18.65
EIRP for WCDMA Band II (Part 24E), Middle Channel										
1880.00	78.68	295	1.8	H	8.6	1.30	9.40	16.70	33	16.3
1880.00	81.55	200	1.1	V	11.3	1.30	9.40	19.40	33	13.6

Note:

Absolute Level = Substituted Level - Cable loss + Antenna Gain

Margin = Limit- Absolute Level

LTE Band 2:

Maximum Output Power

Bandwidth (MHz)	Modulation	RB size/RB Offset	Low Channel (dBm)	Middle Channel (dBm)	High Channel (dBm)
1.4	QPSK	RB Size=1, RB Offset=0	21.63	21.67	21.52
		RB Size=1, RB Offset=2	22.04	21.89	21.94
		RB Size=1, RB Offset=5	22.21	22.12	21.48
		RB Size=3, RB Offset=0	22.04	22.14	22.13
		RB Size=3, RB Offset=1	22.08	21.37	22.15
		RB Size=3, RB Offset=2	21.91	21.99	22.16
		RB Size=6, RB Offset=0	22.24	21.68	22.19
	16QAM	RB Size=1, RB Offset=0	21.89	21.70	21.31
		RB Size=1, RB Offset=2	20.63	20.42	20.45
		RB Size=1, RB Offset=5	20.73	20.58	20.82
		RB Size=3, RB Offset=0	20.55	20.57	20.61
		RB Size=3, RB Offset=1	20.55	20.54	20.70
		RB Size=3, RB Offset=2	20.62	20.63	20.70
		RB Size=6, RB Offset=0	20.66	20.79	20.65
3.0	QPSK	RB Size=1, RB Offset=0	21.50	21.56	21.37
		RB Size=1, RB Offset=7	21.45	21.62	21.62
		RB Size=1, RB Offset=14	21.40	21.33	21.40
		RB Size=8, RB Offset=0	20.61	20.61	20.74
		RB Size=8, RB Offset=4	20.54	20.75	20.82
		RB Size=8, RB Offset=7	20.46	20.63	20.60
		RB Size=15, RB Offset=0	20.65	20.68	20.81
	16QAM	RB Size=1, RB Offset=0	21.64	21.47	21.60
		RB Size=1, RB Offset=7	21.59	21.34	21.47
		RB Size=1, RB Offset=14	21.54	21.01	21.50
		RB Size=8, RB Offset=0	20.71	20.66	20.85
		RB Size=8, RB Offset=4	20.48	20.80	20.87
		RB Size=8, RB Offset=7	20.71	20.65	20.92
		RB Size=15, RB Offset=0	20.50	20.59	20.58

Bandwidth (MHz)	Modulation	RB size/RB Offset	Low Channel (dBm)	Middle Channel (dBm)	High Channel (dBm)
5.0	QPSK	RB Size=1, RB Offset=0	21.26	21.22	21.58
		RB Size=1, RB Offset=12	21.35	21.39	22.58
		RB Size=1, RB Offset=24	21.64	21.52	21.46
		RB Size=12, RB Offset=0	21.14	20.65	20.99
		RB Size=12, RB Offset=6	20.73	20.75	20.92
		RB Size=12, RB Offset=11	20.46	20.69	20.53
		RB Size=25, RB Offset=0	20.59	20.65	20.56
	16QAM	RB Size=1, RB Offset=0	20.57	20.88	20.72
		RB Size=1, RB Offset=12	20.62	20.67	20.62
		RB Size=1, RB Offset=24	22.04	21.49	22.07
		RB Size=12, RB Offset=0	20.80	20.64	20.79
		RB Size=12, RB Offset=6	20.80	20.85	20.71
		RB Size=12, RB Offset=11	20.79	20.69	20.83
		RB Size=25, RB Offset=0	20.66	20.66	20.86
10.0	QPSK	RB Size=1, RB Offset=0	21.53	21.67	21.44
		RB Size=1, RB Offset=24	21.70	21.33	21.60
		RB Size=1, RB Offset=49	21.61	21.12	21.62
		RB Size=25, RB Offset=0	21.43	21.44	21.40
		RB Size=25, RB Offset=12	21.49	21.37	21.28
		RB Size=25, RB Offset=24	21.18	21.30	21.37
		RB Size=50, RB Offset=0	20.88	20.77	20.94
	16QAM	RB Size=1, RB Offset=0	21.05	20.74	20.81
		RB Size=1, RB Offset=24	20.74	20.72	20.62
		RB Size=1, RB Offset=49	20.72	20.70	20.82
		RB Size=25, RB Offset=0	20.70	20.73	20.53
		RB Size=25, RB Offset=12	20.62	20.57	20.44
		RB Size=25, RB Offset=24	20.57	20.83	20.51
		RB Size=50, RB Offset=0	20.46	20.63	20.60

Bandwidth (MHz)	Modulation	RB size/RB Offset	Low Channel (dBm)	Middle Channel (dBm)	High Channel (dBm)
15.0	QPSK	RB Size=1, RB Offset=0	21.73	21.82	21.74
		RB Size=1, RB Offset=37	21.86	21.71	21.81
		RB Size=1, RB Offset=74	21.62	21.69	21.64
		RB Size=36, RB Offset=0	21.84	21.76	21.64
		RB Size=36, RB Offset=18	21.57	21.66	21.54
		RB Size=36, RB Offset=37	21.45	21.57	21.48
		RB Size=75, RB Offset=0	21.10	21.95	21.92
	16QAM	RB Size=1, RB Offset=0	21.01	21.11	22.13
		RB Size=1, RB Offset=37	21.02	21.32	21.33
		RB Size=1, RB Offset=74	21.06	21.11	21.83
		RB Size=36, RB Offset=0	21.36	21.31	21.09
		RB Size=36, RB Offset=18	20.93	21.15	20.99
		RB Size=36, RB Offset=37	20.90	20.89	20.84
		RB Size=75, RB Offset=0	20.63	20.78	20.94
20.0	QPSK	RB Size=1, RB Offset=0	21.62	22.01	21.78
		RB Size=1, RB Offset=49	21.80	21.90	21.93
		RB Size=1, RB Offset=99	21.82	21.88	21.88
		RB Size=50, RB Offset=0	21.63	21.80	21.63
		RB Size=50, RB Offset=24	21.74	21.82	21.43
		RB Size=50, RB Offset=49	21.66	21.76	21.63
		RB Size=100, RB Offset=0	21.50	21.48	21.54
	16QAM	RB Size=1, RB Offset=0	21.35	21.86	21.67
		RB Size=1, RB Offset=49	21.68	21.68	21.83
		RB Size=1, RB Offset=99	21.66	21.72	21.72
		RB Size=50, RB Offset=0	20.77	20.88	20.94
		RB Size=50, RB Offset=24	20.75	20.94	21.16
		RB Size=50, RB Offset=49	20.56	20.55	20.91
		RB Size=100, RB Offset=0	20.73	20.58	20.79

Peak-to-average ratio (PAR)

Modulation	Middle Channel (dB)	PAR Limit (dB)	Result
QPSK (1RB Size)	5.24	13	Pass
QPSK (100RB Size)	5.57	13	Pass
16QAM (1RB Size)	6.22	13	Pass
16QAM (100RB Size)	6.45	13	Pass

QPSK:

Frequency (MHz)	Receiver Reading (dBµV)	Turn table Angle Degree	Rx Antenna		Substituted			Absolute Level (dBm)	Limit (dBm)
			Height (m)	Polar (H/V)	Level (dBm)	Cable Loss (dB)	Antenna Gain (dB)		
Middle Channel									
1.4 MHz Bandwidth									
1880.00	80.80	297	1.8	H	10.8	1.30	9.40	18.90	33
1880.00	77.97	124	1.4	V	7.7	1.30	9.40	15.80	33
3 MHz Bandwidth									
1880.00	80.36	318	1.3	H	10.3	1.30	9.40	18.40	33
1880.00	78.87	215	1.8	V	8.6	1.30	9.40	16.70	33
5 MHz Bandwidth									
1880.00	79.83	260	1.6	H	9.8	1.30	9.40	17.90	33
1880.00	80.14	304	1.0	V	9.9	1.30	9.40	18.00	33
10 MHz Bandwidth									
1880.00	80.50	150	2.1	H	10.5	1.30	9.40	18.60	33
1880.00	80.99	241	1.8	V	10.7	1.30	9.40	18.80	33
15 MHz Bandwidth									
1880.00	80.27	196	1.3	H	10.2	1.30	9.40	18.30	33
1880.00	80.45	22	1.1	V	10.2	1.30	9.40	18.30	33
20 MHz Bandwidth									
1880.00	80.14	121	2.0	H	10.1	1.30	9.40	18.20	33
1880.00	80.29	4	2.5	V	10.0	1.30	9.40	18.10	33

16QAM:

Frequency (MHz)	Receiver Reading (dBµV)	Turn table Angle Degree	Rx Antenna		Substituted			Absolute Level (dBm)	Limit (dBm)
			Height (m)	Polar (H/V)	Level (dBm)	Cable Loss (dB)	Antenna Gain (dB)		
Middle Channel									
1.4 MHz Bandwidth									
1880.00	80.02	347	1.5	H	10.0	1.30	9.40	18.10	33
1880.00	78.76	170	2.4	V	8.5	1.30	9.40	16.60	33
3 MHz Bandwidth									
1880.00	80.11	269	2.4	H	10.1	1.30	9.40	18.20	33
1880.00	78.49	288	1.7	V	8.2	1.30	9.40	16.30	33
5 MHz Bandwidth									
1880.00	80.46	6	1.4	H	10.4	1.30	9.40	18.50	33
1880.00	78.27	231	1.4	V	8.0	1.30	9.40	16.10	33
10 MHz Bandwidth									
1880.00	80.28	344	1.2	H	10.2	1.30	9.40	18.30	33
1880.00	79.64	115	1.9	V	9.4	1.30	9.40	17.50	33
15 MHz Bandwidth									
1880.00	79.94	330	1.5	H	9.9	1.30	9.40	18.00	33
1880.00	77.62	269	1.7	V	7.4	1.30	9.40	15.50	33
20 MHz Bandwidth									
1880.00	79.92	239	2.4	H	9.9	1.30	9.40	18.00	33
1880.00	77.58	355	1.4	V	7.3	1.30	9.40	15.40	33

LTE Band 4:

Maximum Output Power

Bandwidth (MHz)	Modulation	RB size/RB Offset	Low Channel (dBm)	Middle Channel (dBm)	High Channel (dBm)
1.4	QPSK	RB Size=1, RB Offset=0	21.49	21.48	21.54
		RB Size=1, RB Offset=2	21.78	22.04	21.57
		RB Size=1, RB Offset=5	21.60	21.59	21.82
		RB Size=3, RB Offset=0	21.92	21.76	21.86
		RB Size=3, RB Offset=1	21.80	21.80	21.95
		RB Size=3, RB Offset=2	21.73	21.68	21.77
		RB Size=6, RB Offset=0	21.08	21.05	20.84
	16QAM	RB Size=1, RB Offset=0	20.77	21.07	20.96
		RB Size=1, RB Offset=2	20.73	20.87	21.13
		RB Size=1, RB Offset=5	20.62	20.77	20.57
		RB Size=3, RB Offset=0	21.80	22.05	22.00
		RB Size=3, RB Offset=1	21.87	21.44	21.65
		RB Size=3, RB Offset=2	21.22	20.87	20.72
		RB Size=6, RB Offset=0	20.90	20.63	20.60
3.0	QPSK	RB Size=1, RB Offset=0	21.76	21.99	21.82
		RB Size=1, RB Offset=7	21.82	22.13	21.88
		RB Size=1, RB Offset=14	21.70	21.85	21.71
		RB Size=8, RB Offset=0	21.47	21.38	21.54
		RB Size=8, RB Offset=4	21.56	21.51	21.52
		RB Size=8, RB Offset=7	21.38	21.40	21.71
		RB Size=15, RB Offset=0	21.73	21.87	21.66
	16QAM	RB Size=1, RB Offset=0	21.83	21.63	21.75
		RB Size=1, RB Offset=7	21.41	21.47	21.59
		RB Size=1, RB Offset=14	21.29	21.48	21.54
		RB Size=8, RB Offset=0	20.96	20.88	20.92
		RB Size=8, RB Offset=4	20.87	21.01	20.92
		RB Size=8, RB Offset=7	20.66	20.76	20.77
		RB Size=15, RB Offset=0	20.73	20.59	20.58

Bandwidth (MHz)	Modulation	RB size/RB Offset	Low Channel (dBm)	Middle Channel (dBm)	High Channel (dBm)
5.0	QPSK	RB Size=1, RB Offset=0	21.79	21.64	21.80
		RB Size=1, RB Offset=12	21.92	21.98	22.87
		RB Size=1, RB Offset=24	21.77	21.86	22.74
		RB Size=12, RB Offset=0	21.67	21.82	22.01
		RB Size=12, RB Offset=6	21.89	21.79	22.01
		RB Size=12, RB Offset=11	21.90	22.02	22.13
		RB Size=25, RB Offset=0	21.86	22.01	21.95
	16QAM	RB Size=1, RB Offset=0	22.11	21.87	21.82
		RB Size=1, RB Offset=12	21.81	21.83	21.91
		RB Size=1, RB Offset=24	21.58	21.48	21.40
		RB Size=12, RB Offset=0	20.70	21.13	20.92
		RB Size=12, RB Offset=6	20.99	21.09	20.94
		RB Size=12, RB Offset=11	21.01	21.03	20.74
		RB Size=25, RB Offset=0	20.78	20.74	20.70
10.0	QPSK	RB Size=1, RB Offset=0	21.71	22.46	22.66
		RB Size=1, RB Offset=24	21.33	22.38	22.50
		RB Size=1, RB Offset=49	21.40	22.14	22.07
		RB Size=25, RB Offset=0	21.38	22.00	21.88
		RB Size=25, RB Offset=12	21.60	21.81	21.78
		RB Size=25, RB Offset=24	21.87	21.79	21.95
		RB Size=50, RB Offset=0	21.72	21.85	21.82
	16QAM	RB Size=1, RB Offset=0	21.57	22.68	22.86
		RB Size=1, RB Offset=24	21.55	21.74	21.62
		RB Size=1, RB Offset=49	21.06	21.28	21.74
		RB Size=25, RB Offset=0	20.93	20.82	20.72
		RB Size=25, RB Offset=12	20.78	21.22	20.90
		RB Size=25, RB Offset=24	20.99	20.77	21.25
		RB Size=50, RB Offset=0	20.83	20.91	20.74

Bandwidth (MHz)	Modulation	RB size/RB Offset	Low Channel (dBm)	Middle Channel (dBm)	High Channel (dBm)
15.0	QPSK	RB Size=1, RB Offset=0	21.82	21.81	22.10
		RB Size=1, RB Offset=37	22.04	21.69	21.83
		RB Size=1, RB Offset=74	22.03	22.08	22.01
		RB Size=36, RB Offset=0	20.69	20.75	21.38
		RB Size=36, RB Offset=18	20.46	20.63	21.28
		RB Size=36, RB Offset=37	20.42	21.10	21.23
		RB Size=75, RB Offset=0	21.40	21.64	21.24
	16QAM	RB Size=1, RB Offset=0	21.33	20.97	21.26
		RB Size=1, RB Offset=37	21.08	21.21	21.13
		RB Size=1, RB Offset=74	21.05	20.91	21.04
		RB Size=36, RB Offset=0	21.13	20.97	20.85
		RB Size=36, RB Offset=18	20.93	20.95	20.70
		RB Size=36, RB Offset=37	20.81	20.92	20.80
		RB Size=75, RB Offset=0	20.68	20.95	20.78
20.0	QPSK	RB Size=1, RB Offset=0	21.90	21.99	21.99
		RB Size=1, RB Offset=49	22.19	22.04	22.05
		RB Size=1, RB Offset=99	22.14	21.71	22.12
		RB Size=50, RB Offset=0	20.77	21.80	21.59
		RB Size=50, RB Offset=24	20.55	21.62	21.45
		RB Size=50, RB Offset=49	20.62	20.47	21.12
		RB Size=100, RB Offset=0	20.53	21.00	21.26
	16QAM	RB Size=1, RB Offset=0	21.68	21.47	21.64
		RB Size=1, RB Offset=49	21.60	21.29	21.66
		RB Size=1, RB Offset=99	21.29	21.29	21.27
		RB Size=50, RB Offset=0	20.95	20.80	20.79
		RB Size=50, RB Offset=24	21.27	20.82	20.80
		RB Size=50, RB Offset=49	20.60	20.74	20.60
		RB Size=100, RB Offset=0	20.59	20.48	20.66

Peak-to-average ratio (PAR)

Modulation	Middle Channel (dB)	PAR Limit (dB)	Result
QPSK (1RB Size)	5.24	13	Pass
QPSK (100RB Size)	5.57	13	Pass
16QAM (1RB Size)	6.22	13	Pass
16QAM (100RB Size)	6.45	13	Pass

QPSK:

Frequency (MHz)	Receiver Reading (dBμV)	Turn table Angle Degree	Rx Antenna		Substituted			Absolute Level (dBm)	Limit (dBm)
			Height (m)	Polar (H/V)	Level (dBm)	Cable Loss (dB)	Antenna Gain (dB)		
Middle Channel									
1.4 MHz Bandwidth									
1732.50	83.34	340	1.9	H	10.2	1.30	8.90	17.80	30
1732.50	85.37	246	1.1	V	12.8	1.30	8.90	20.40	30
3 MHz Bandwidth									
1732.50	84.49	343	2.1	H	11.3	1.30	8.90	18.90	30
1732.50	85.63	107	1.1	V	13.1	1.30	8.90	20.70	30
5 MHz Bandwidth									
1732.50	83.69	83	1.5	H	10.5	1.30	8.90	18.10	30
1732.50	85.84	264	2.3	V	13.3	1.30	8.90	20.90	30
10 MHz Bandwidth									
1732.50	84.14	217	2.5	H	11.0	1.30	8.90	18.60	30
1732.50	85.74	203	1.8	V	13.2	1.30	8.90	20.80	30
15 MHz Bandwidth									
1732.50	85.29	349	1.8	H	12.1	1.30	8.90	19.70	30
1732.50	85.76	341	2.2	V	13.2	1.30	8.90	20.80	30
20 MHz Bandwidth									
1732.50	84.59	311	1.5	H	11.4	1.30	8.90	19.00	30
1732.50	86.04	317	1.3	V	13.5	1.30	8.90	21.10	30

16QAM:

Frequency (MHz)	Receiver Reading (dBµV)	Turn table Angle Degree	Rx Antenna		Substituted			Absolute Level (dBm)	Limit (dBm)
			Height (m)	Polar (H/V)	Level (dBm)	Cable Loss (dB)	Antenna Gain (dB)		
Middle Channel									
1.4 MHz Bandwidth									
1732.50	83.28	196	1.8	H	10.1	1.30	8.90	17.70	30
1732.50	83.87	132	1.6	V	11.3	1.30	8.90	18.90	30
3 MHz Bandwidth									
1732.50	83.11	298	1.4	H	9.9	1.30	8.90	17.50	30
1732.50	83.29	185	1.4	V	10.7	1.30	8.90	18.30	30
5 MHz Bandwidth									
1732.50	82.97	74	1.8	H	9.8	1.30	8.90	17.40	30
1732.50	83.56	170	1.2	V	11.0	1.30	8.90	18.60	30
10 MHz Bandwidth									
1732.50	83.64	351	1.9	H	10.5	1.30	8.90	18.10	30
1732.50	83.43	135	1.6	V	10.9	1.30	8.90	18.50	30
15 MHz Bandwidth									
1732.50	83.09	71	1.4	H	9.9	1.30	8.90	17.50	30
1732.50	83.67	191	2.0	V	11.1	1.30	8.90	18.70	30
20 MHz Bandwidth									
1732.50	82.75	147	1.7	H	9.6	1.30	8.90	17.20	30
1732.50	83.39	166	2.1	V	10.8	1.30	8.90	18.40	30

LTE Band 5:

Maximum Output Power

Bandwidth (MHz)	Modulation	RB size/RB Offset	Low Channel (dBm)	Middle Channel (dBm)	High Channel (dBm)
1.4	QPSK	RB Size=1, RB Offset=0	21.55	21.72	21.65
		RB Size=1, RB Offset=2	21.75	21.99	21.78
		RB Size=1, RB Offset=5	22.22	22.29	21.45
		RB Size=3, RB Offset=0	21.96	22.16	22.01
		RB Size=3, RB Offset=1	21.97	21.44	22.18
		RB Size=3, RB Offset=2	22.05	22.21	22.01
		RB Size=6, RB Offset=0	22.23	21.87	22.24
	16QAM	RB Size=1, RB Offset=0	21.83	21.83	21.42
		RB Size=1, RB Offset=2	20.51	20.65	20.54
		RB Size=1, RB Offset=5	20.72	20.71	20.94
		RB Size=3, RB Offset=0	20.68	20.79	20.71
		RB Size=3, RB Offset=1	20.48	20.61	20.83
		RB Size=3, RB Offset=2	20.44	20.52	20.67
		RB Size=6, RB Offset=0	20.66	20.76	20.55
3.0	QPSK	RB Size=1, RB Offset=0	21.40	21.37	21.57
		RB Size=1, RB Offset=7	21.53	21.64	21.68
		RB Size=1, RB Offset=14	21.46	21.60	21.24
		RB Size=8, RB Offset=0	20.64	20.50	20.69
		RB Size=8, RB Offset=4	20.77	20.79	20.65
		RB Size=8, RB Offset=7	20.55	20.54	20.72
		RB Size=15, RB Offset=0	20.75	20.69	20.70
	16QAM	RB Size=1, RB Offset=0	21.38	21.30	21.70
		RB Size=1, RB Offset=7	21.40	21.21	21.49
		RB Size=1, RB Offset=14	21.43	21.14	21.52
		RB Size=8, RB Offset=0	20.65	20.69	20.81
		RB Size=8, RB Offset=4	20.58	20.72	20.88
		RB Size=8, RB Offset=7	20.68	20.73	20.92
		RB Size=15, RB Offset=0	20.63	20.74	20.47

Bandwidth (MHz)	Modulation	RB size/RB Offset	Low Channel (dBm)	Middle Channel (dBm)	High Channel (dBm)
5.0	QPSK	RB Size=1, RB Offset=0	21.25	21.38	21.59
		RB Size=1, RB Offset=12	21.32	21.39	22.48
		RB Size=1, RB Offset=24	21.47	21.63	21.59
		RB Size=12, RB Offset=0	20.95	20.59	20.81
		RB Size=12, RB Offset=6	20.54	20.82	20.66
		RB Size=12, RB Offset=11	20.46	20.62	20.38
		RB Size=25, RB Offset=0	20.68	20.74	20.75
	16QAM	RB Size=1, RB Offset=0	20.63	20.78	20.98
		RB Size=1, RB Offset=12	20.61	20.55	20.59
		RB Size=1, RB Offset=24	21.97	21.39	21.99
		RB Size=12, RB Offset=0	20.76	20.70	20.86
		RB Size=12, RB Offset=6	20.73	20.75	20.79
		RB Size=12, RB Offset=11	20.71	20.69	20.70
		RB Size=25, RB Offset=0	20.57	20.58	20.74
10.0	QPSK	RB Size=1, RB Offset=0	21.56	21.68	21.43
		RB Size=1, RB Offset=24	21.62	21.46	21.46
		RB Size=1, RB Offset=49	21.60	21.08	21.60
		RB Size=25, RB Offset=0	21.48	21.54	21.44
		RB Size=25, RB Offset=12	21.46	21.34	21.32
		RB Size=25, RB Offset=24	21.21	21.09	21.21
		RB Size=50, RB Offset=0	20.64	20.95	20.85
	16QAM	RB Size=1, RB Offset=0	20.91	20.78	20.67
		RB Size=1, RB Offset=24	20.65	20.77	20.77
		RB Size=1, RB Offset=49	20.69	20.56	20.71
		RB Size=25, RB Offset=0	20.64	20.86	20.55
		RB Size=25, RB Offset=12	20.52	20.61	20.72
		RB Size=25, RB Offset=24	20.64	20.64	20.59
		RB Size=50, RB Offset=0	20.49	20.49	20.61

Peak-to-average ratio (PAR)

Modulation	Middle Channel (dB)	PAR Limit (dB)	Result
QPSK (1RB Size)	5.52	13	Pass
QPSK (50RB Size)	5.43	13	Pass
16QAM (1RB Size)	6.22	13	Pass
16QAM (50RB Size)	6.24	13	Pass

QPSK:

Frequency (MHz)	Receiver Reading (dBµV)	Turn table Angle Degree	Rx Antenna		Substituted			Absolute Level (dBm)	Limit (dBm)
			Height (m)	Polar (H/V)	Level (dBm)	Cable Loss (dB)	Antenna Gain (dB)		
Middle Channel									
1.4 MHz Bandwidth									
836.5	79.75	73	2.5	H	17.7	0.7	0.0	17.00	38.45
836.5	80.02	355	1.1	V	19.6	0.7	0.0	18.90	38.45
3 MHz Bandwidth									
836.5	78.82	312	2.2	H	16.8	0.7	0.0	16.10	38.45
836.5	80.43	281	1.5	V	20.0	0.7	0.0	19.30	38.45
5 MHz Bandwidth									
836.5	79.87	201	2.1	H	17.8	0.7	0.0	17.10	38.45
836.5	80.29	147	2.4	V	19.9	0.7	0.0	19.20	38.45
10 MHz Bandwidth									
836.5	79.87	201	2.1	H	17.8	0.7	0.0	17.10	38.45
836.5	80.29	147	2.4	V	19.9	0.7	0.0	19.20	38.45

16QAM:

Frequency (MHz)	Receiver Reading (dBµV)	Turn table Angle Degree	Rx Antenna		Substituted			Absolute Level (dBm)	Limit (dBm)
			Height (m)	Polar (H/V)	Level (dBm)	Cable Loss (dB)	Antenna Gain (dB)		
Middle Channel									
1.4 MHz Bandwidth									
836.5	79.83	61	1.8	H	17.8	0.7	0.0	17.10	38.45
836.5	79.64	315	2.3	V	19.2	0.7	0.0	18.50	38.45
3 MHz Bandwidth									
836.5	80.71	342	1.0	H	18.7	0.7	0.0	18.00	38.45
836.5	80.24	59	2.0	V	19.8	0.7	0.0	19.10	38.45
5 MHz Bandwidth									
836.5	80.2	211	2.4	H	18.2	0.7	0.0	17.50	38.45
836.5	79.52	58	1.6	V	19.1	0.7	0.0	18.40	38.45
10 MHz Bandwidth									
836.5	78.81	47	2.0	H	16.8	0.7	0.0	16.10	38.45
836.5	79.44	62	1.5	V	19.0	0.7	0.0	18.30	38.45

LTE Band 7:

Bandwidth (MHz)	Modulation	RB size/RB Offset	Low Channel (dBm)	Middle Channel (dBm)	High Channel (dBm)
5	QPSK	RB Size=1, RB Offset=0	21.37	21.77	21.73
		RB Size=1, RB Offset=12	21.64	21.70	21.88
		RB Size=1, RB Offset=24	21.63	21.91	21.72
		RB Size=12, RB Offset=0	21.67	21.70	21.82
		RB Size=12, RB Offset=6	21.81	21.55	21.82
		RB Size=12, RB Offset=11	21.58	21.61	21.71
		RB Size=25, RB Offset=0	21.52	21.50	21.72
	16QAM	RB Size=1, RB Offset=0	21.60	21.12	21.33
		RB Size=1, RB Offset=12	21.54	21.42	21.29
		RB Size=1, RB Offset=24	21.83	21.92	21.64
		RB Size=12, RB Offset=0	21.02	21.16	21.05
		RB Size=12, RB Offset=6	20.89	21.16	21.09
		RB Size=12, RB Offset=11	20.64	21.07	20.79
		RB Size=25, RB Offset=0	20.98	21.03	20.79
10	QPSK	RB Size=1, RB Offset=0	21.65	21.71	21.75
		RB Size=1, RB Offset=24	21.51	21.71	21.53
		RB Size=1, RB Offset=49	21.70	21.61	21.71
		RB Size=25, RB Offset=0	21.62	21.71	21.51
		RB Size=25, RB Offset=12	21.70	21.83	21.93
		RB Size=25, RB Offset=24	21.92	21.82	21.86
		RB Size=50, RB Offset=0	21.77	21.67	21.72
	16QAM	RB Size=1, RB Offset=0	21.92	21.97	21.83
		RB Size=1, RB Offset=24	21.99	21.78	21.70
		RB Size=1, RB Offset=49	20.62	20.85	20.75
		RB Size=25, RB Offset=0	21.60	20.73	20.60
		RB Size=25, RB Offset=12	20.61	20.71	20.89
		RB Size=25, RB Offset=24	20.52	20.69	20.99
		RB Size=50, RB Offset=0	20.58	20.60	20.48

Bandwidth (MHz)	Modulation	RB size/RB Offset	Low Channel (dBm)	Middle Channel (dBm)	High Channel (dBm)
15	QPSK	RB Size=1, RB Offset=0	21.54	21.58	21.24
		RB Size=1, RB Offset=37	21.49	21.56	21.45
		RB Size=1, RB Offset=74	21.62	21.54	21.48
		RB Size=36, RB Offset=0	21.63	21.61	21.51
		RB Size=36, RB Offset=18	21.69	21.09	21.75
		RB Size=36, RB Offset=37	21.56	21.46	21.44
		RB Size=75, RB Offset=0	21.34	21.61	21.27
	16QAM	RB Size=1, RB Offset=0	21.53	21.55	21.55
		RB Size=1, RB Offset=37	21.62	21.81	21.64
		RB Size=1, RB Offset=74	21.56	21.60	21.78
		RB Size=36, RB Offset=0	21.90	21.71	21.70
		RB Size=36, RB Offset=18	20.70	20.76	20.98
		RB Size=36, RB Offset=37	20.93	20.73	20.92
		RB Size=75, RB Offset=0	20.72	20.67	21.16
20	QPSK	RB Size=1, RB Offset=0	22.05	22.20	21.98
		RB Size=1, RB Offset=49	21.19	21.99	21.15
		RB Size=1, RB Offset=99	22.04	21.71	21.90
		RB Size=50, RB Offset=0	22.19	22.11	22.06
		RB Size=50, RB Offset=24	22.09	22.08	22.25
		RB Size=50, RB Offset=49	21.06	22.15	21.22
		RB Size=100, RB Offset=0	21.75	22.74	21.83
	16QAM	RB Size=1, RB Offset=0	21.40	22.52	21.22
		RB Size=1, RB Offset=49	21.94	21.88	21.83
		RB Size=1, RB Offset=99	22.15	21.93	22.22
		RB Size=50, RB Offset=0	20.96	20.97	21.13
		RB Size=50, RB Offset=24	21.05	20.89	20.90
		RB Size=50, RB Offset=49	20.99	21.13	20.99
		RB Size=100, RB Offset=0	20.95	20.95	20.85

Peak-to-average ratio (PAR)

Modulation	Middle Channel (dB)	PAR Limit (dB)	Result
QPSK (1RB Size)	5.58	13	Pass
QPSK (100RB Size)	5.72	13	Pass
16QAM (1RB Size)	6.26	13	Pass
16QAM (100RB Size)	6.34	13	Pass

EIRP:

QPSK:

Frequency (MHz)	Receiver Reading (dBµV)	Turn table Angle Degree	Rx Antenna		Substituted			Absolute Level (dBm)	Limit (dBm)
			Height (m)	Polar (H/V)	Level (dBm)	Cable Loss (dB)	Antenna Gain (dB)		
Middle Channel									
5MHz Bandwidth									
2535.00	82.14	291	2.4	H	12.7	2.60	10.20	20.30	33
2535.00	79.26	328	1.7	V	10.4	2.60	10.20	18.00	33
10 MHz Bandwidth									
2535.00	82.77	14	2.2	H	13.3	2.60	10.20	20.90	33
2535.00	79.15	34	1.1	V	10.3	2.60	10.20	17.90	33
15 MHz Bandwidth									
2535.00	81.95	51	1.3	H	12.5	2.60	10.20	20.10	33
2535.00	79.03	285	1.2	V	10.2	2.60	10.20	17.80	33
20 MHz Bandwidth									
2535.00	82.21	210	1.7	H	12.7	2.60	10.20	20.30	33
2535.00	79.44	186	1.5	V	10.6	2.60	10.20	18.20	33

16QAM:

Frequency (MHz)	Receiver Reading (dBµV)	Turn table Angle Degree	Rx Antenna		Substituted			Absolute Level (dBm)	Limit (dBm)
			Height (m)	Polar (H/V)	Level (dBm)	Cable Loss (dB)	Antenna Gain (dB)		
Middle Channel									
1.4 MHz Bandwidth									
2535.00	81.91	264	1.5	H	12.4	2.60	10.20	20.00	33
2535.00	79.03	145	1.3	V	10.2	2.60	10.20	17.80	33
3 MHz Bandwidth									
2535.00	82.64	236	1.7	H	13.2	2.60	10.20	20.80	33
2535.00	79.15	335	1.5	V	10.3	2.60	10.20	17.90	33
5MHz Bandwidth									
2535.00	81.86	117	2.0	H	12.4	2.60	10.20	20.00	33
2535.00	79.34	184	1.5	V	10.5	2.60	10.20	18.10	33
10 MHz Bandwidth									
2535.00	81.74	127	2.4	H	12.3	2.60	10.20	19.90	33
2535.00	78.50	59	1.3	V	9.6	2.60	10.20	17.20	33

Note:

All above data were tested with no amplifier

Absolute Level = Substituted Level - Cable loss + Antenna Gain

Margin = Limit- Absolute Level

FCC §2.1049, §22.917, §22.905 & §24.238 & §27.53 - OCCUPIED BANDWIDTH

Applicable Standard

FCC 47 §2.1049, §22.917, §22.905, §24.238 and §27.53.

Test Procedure

The RF output of the transmitter was connected to the simulator and the spectrum analyzer through sufficient attenuation.

The resolution bandwidth of the spectrum analyzer was set at 1% to 5% of the anticipated emission bandwidth and the 26 dB & 99% bandwidth was recorded.

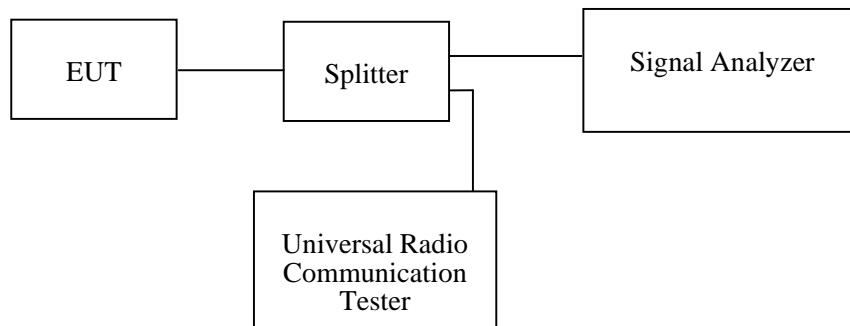

Test Data

Environmental Conditions

Temperature:	21~25 °C
Relative Humidity:	51!52 %
ATM Pressure:	100.5~101.0 kPa

The testing was performed by Tracy Hu from 2018-04-14 to 2018-05-15.

EUT operation mode: Transmitting

Test Result: Compliance. Please refer to the following tables and plots.

Cellular Band (Part 22H)

Mode	Frequency (MHz)	99% Occupied Bandwidth (kHz)	26 dB Emission Bandwidth (kHz)
GSM(GMSK)	836.6	246.79	322.12
EGPRS(8PSK)	836.6	248.40	315.71

Mode	Frequency (MHz)	99% Occupied Bandwidth (MHz)	26 dB Emission Bandwidth (MHz)
RMC (BPSK)	836.6	4.183	4.728
HSUPA (BPSK)	836.6	4.199	4.728
HSDPA (16QAM)	836.6	4.183	4.728

PCS Band (Part 24E)

Mode	Frequency (MHz)	99% Occupied Bandwidth (kHz)	26 dB Emission Bandwidth (kHz)
GSM(GMSK)	1880.0	243.60	314.10
EGPRS(8PSK)	1880.0	246.79	310.90

Mode	Frequency (MHz)	99% Occupied Bandwidth (MHz)	26 dB Emission Bandwidth (MHz)
RMC (BPSK)	1880.0	4.167	4.744
HSUPA (BPSK)	1880.0	4.167	4.728
HSDPA (16QAM)	1880.0	4.167	4.744

Cellular Band (Part 22H)

26 dB Emissions & 99% Occupied Bandwidth for GSM (GMSK) Mode

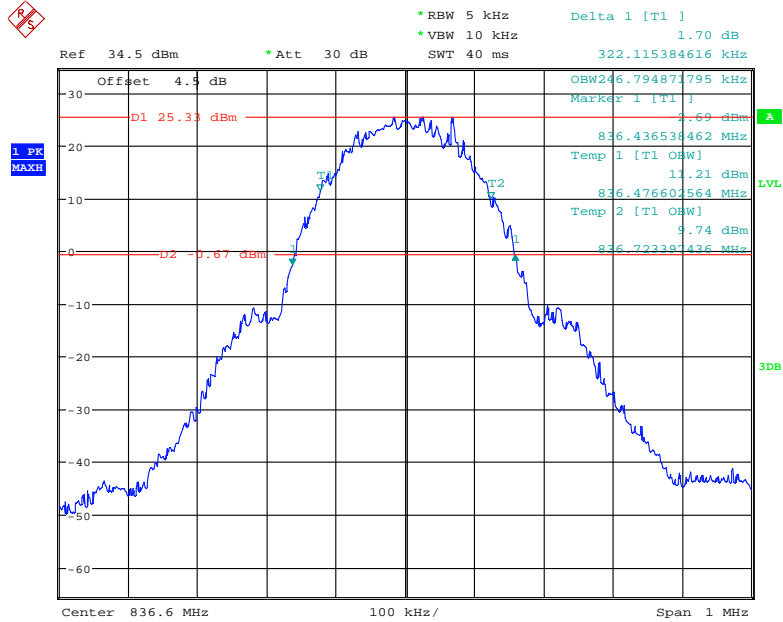

Date: 14.APR.2018 11:06:08

26 dB Emissions & 99% Occupied Bandwidth for EDGE Mode

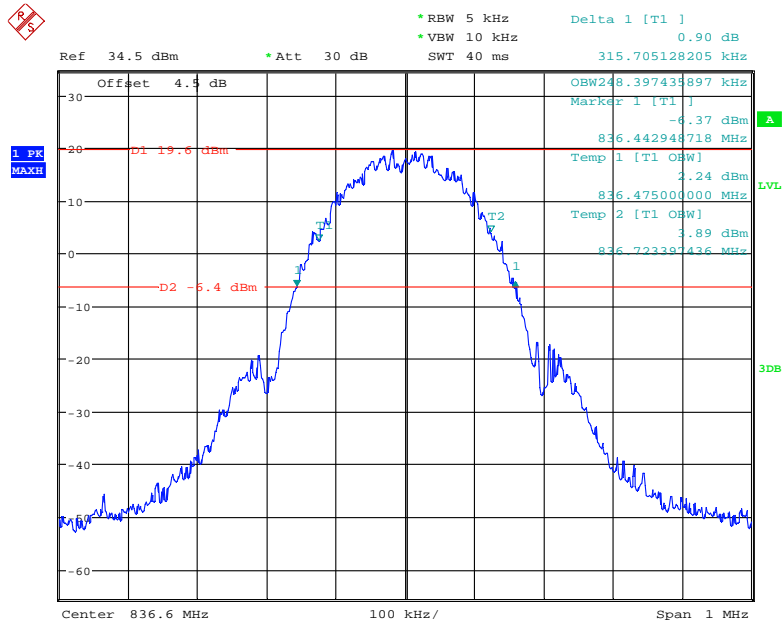

Date: 14.APR.2018 11:26:48

26 dB Emissions & 99% Occupied Bandwidth for RMC (BPSK) Mode

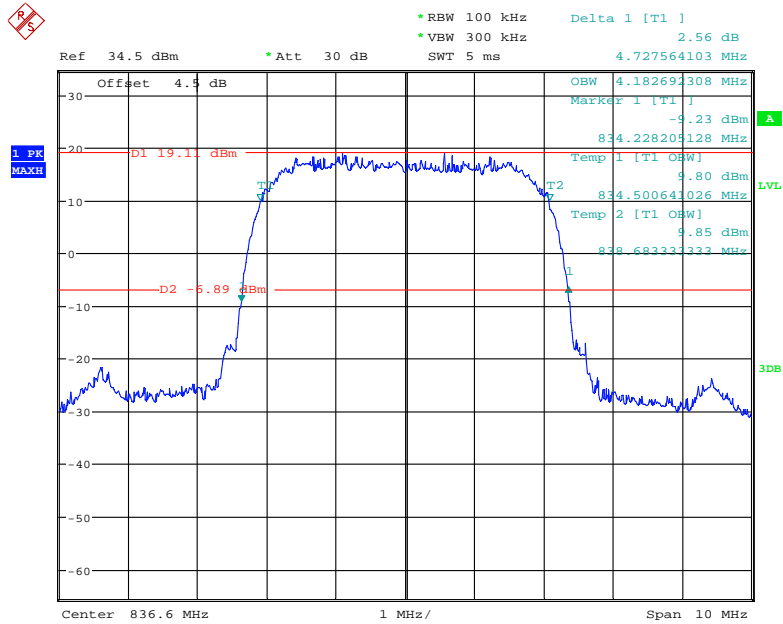

Date: 14.APR.2018 14:20:20

26 dB Emissions & 99% Occupied Bandwidth for HSUPA (BPSK) Mode

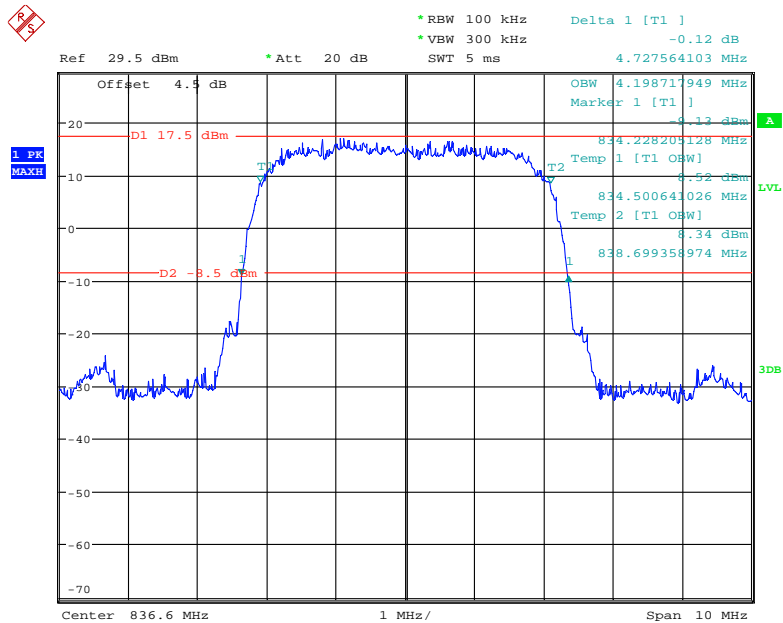

Date: 14.APR.2018 14:40:18

26 dB Emissions & 99% Occupied Bandwidth for HSDPA (16QAM) Mode

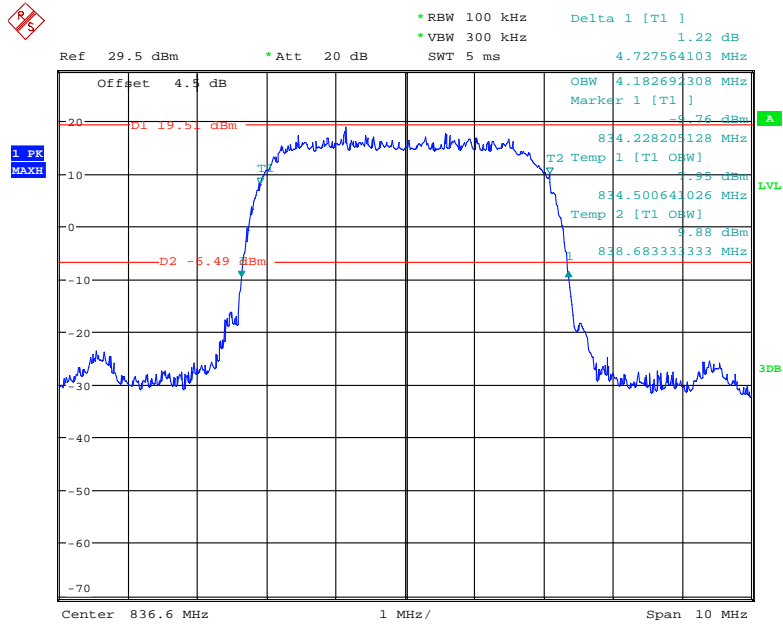

Date: 14.APR.2018 14:52:02

PCS Band (Part 24E)

26 dB Emissions & 99% Occupied Bandwidth for GSM (GMSK) Mode

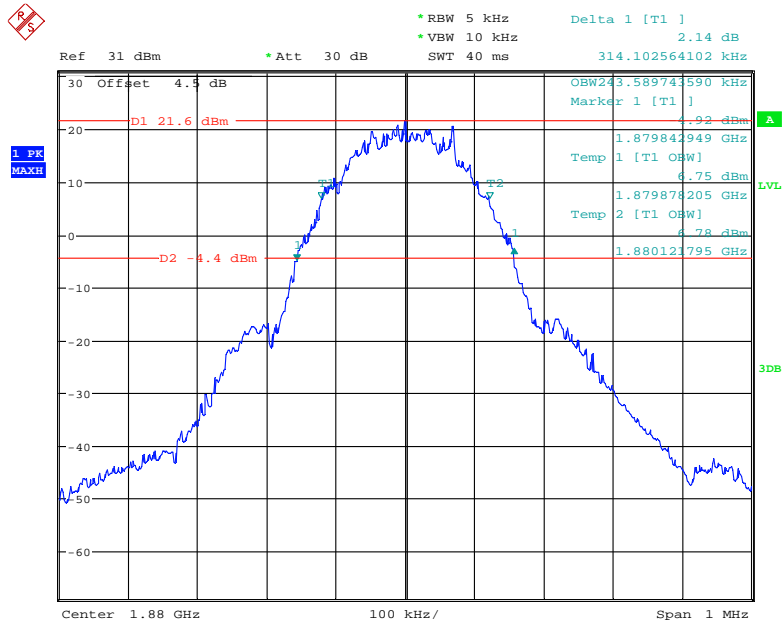

Date: 14.APR.2018 11:19:22

26 dB Emissions & 99% Occupied Bandwidth for EDGE Mode

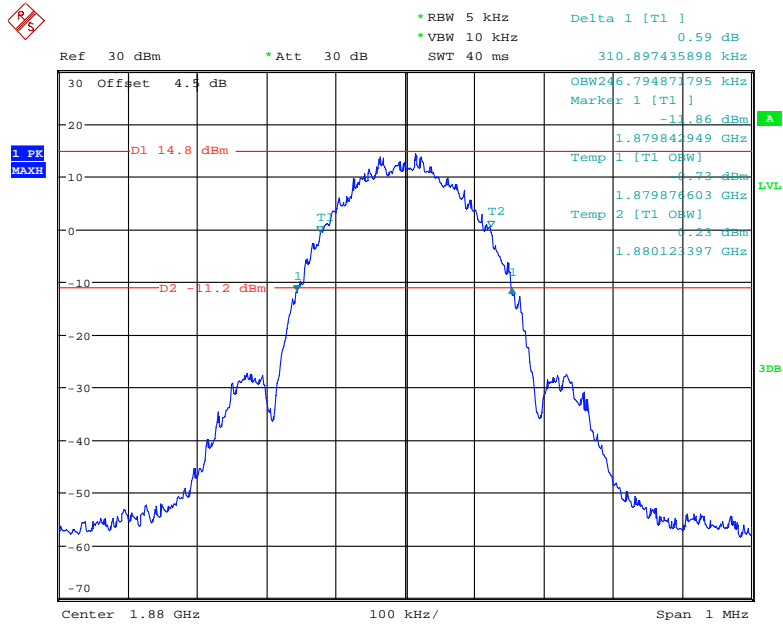

Date: 14.APR.2018 11:35:44

26 dB Emissions & 99% Occupied Bandwidth for RMC (BPSK) Mode

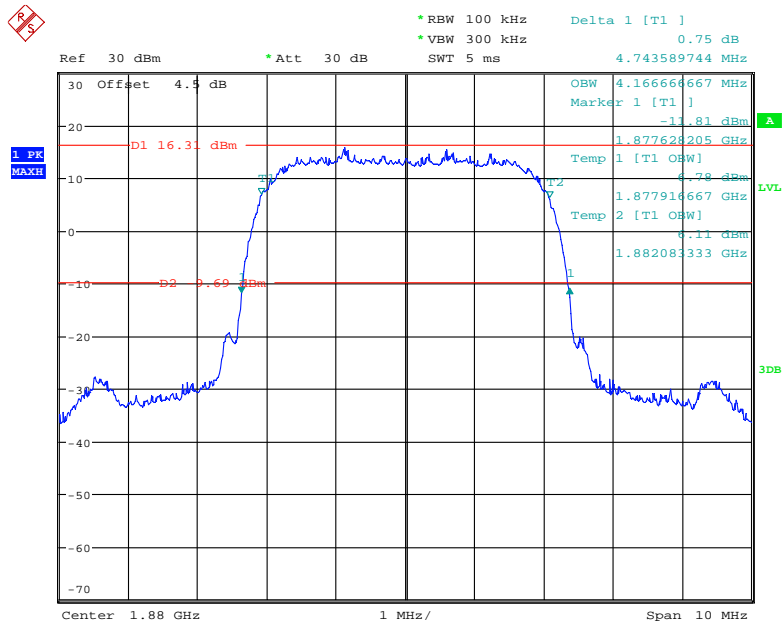

Date: 14.APR.2018 14:10:27

26 dB Emissions & 99% Occupied Bandwidth for HSUPA (BPSK) Mode

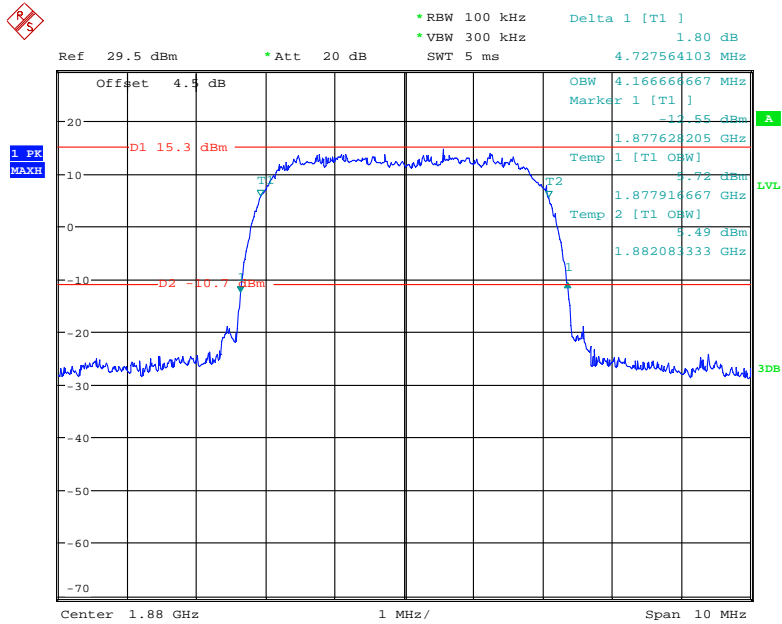

Date: 14.APR.2018 14:43:06

26 dB Emissions & 99% Occupied Bandwidth for HSDPA (16QAM) Mode

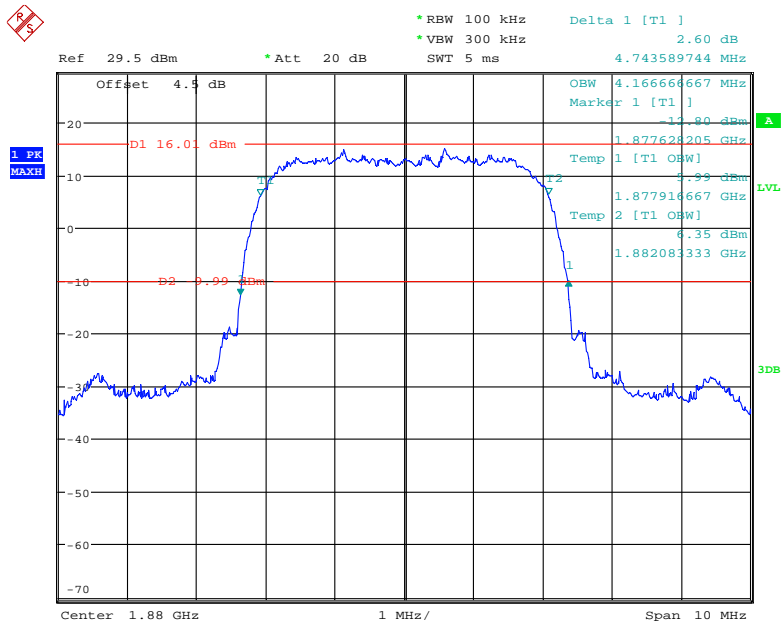

Date: 14.APR.2018 14:55:37

LTE Band 2: (Middle Channel)

Bandwidth (MHz)	Modulation	99% Occupied Bandwidth (MHz)	26 dB Emission Bandwidth (MHz)
1.4	QPSK	1.096	1.313
	16QAM	1.106	1.327
3.0	QPSK	2.683	2.875
	16QAM	2.683	2.894
5.0	QPSK	4.535	5.154
	16QAM	4.519	5.346
10.0	QPSK	8.974	9.978
	16QAM	8.974	9.913
15.0	QPSK	13.558	15.154
	16QAM	13.462	14.913
20.0	QPSK	17.949	19.359
	16QAM	17.949	19.487

QPSK (1.4 MHz) - 26 dB Bandwidth & 99% Occupied Bandwidth, Middle channel

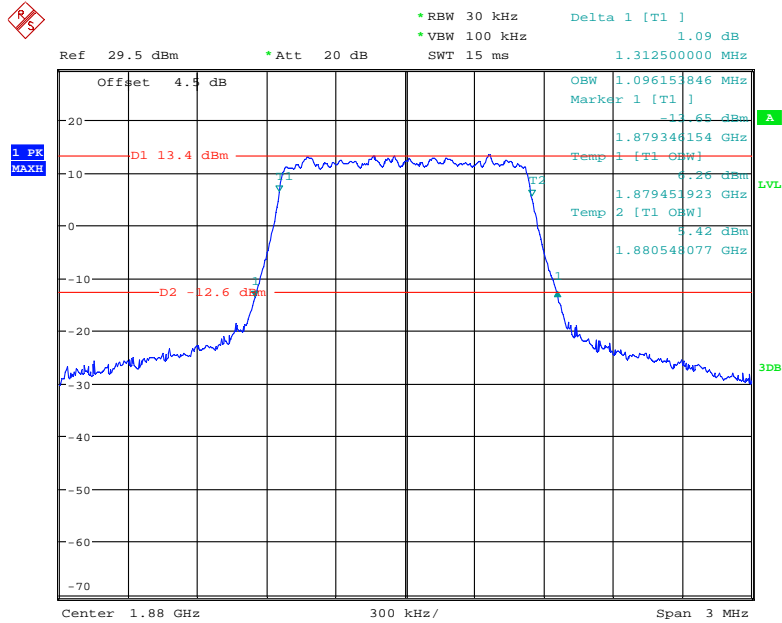

Date: 17.APR.2018 09:30:24

16-QAM (1.4 MHz) - 26 dB Bandwidth & 99% Occupied Bandwidth, Middle channel

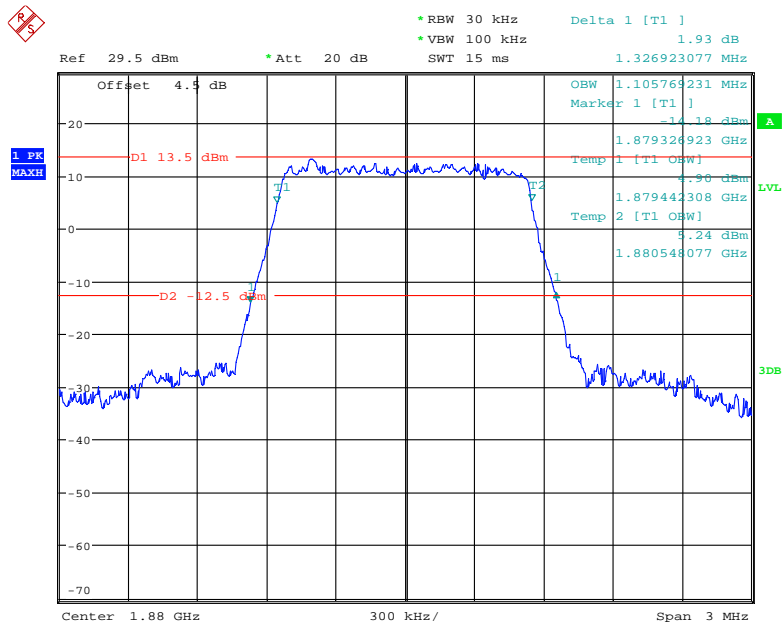

Date: 17.APR.2018 09:48:42

QPSK (3.0 MHz) - 26 dB Bandwidth & 99% Occupied Bandwidth, Middle channel

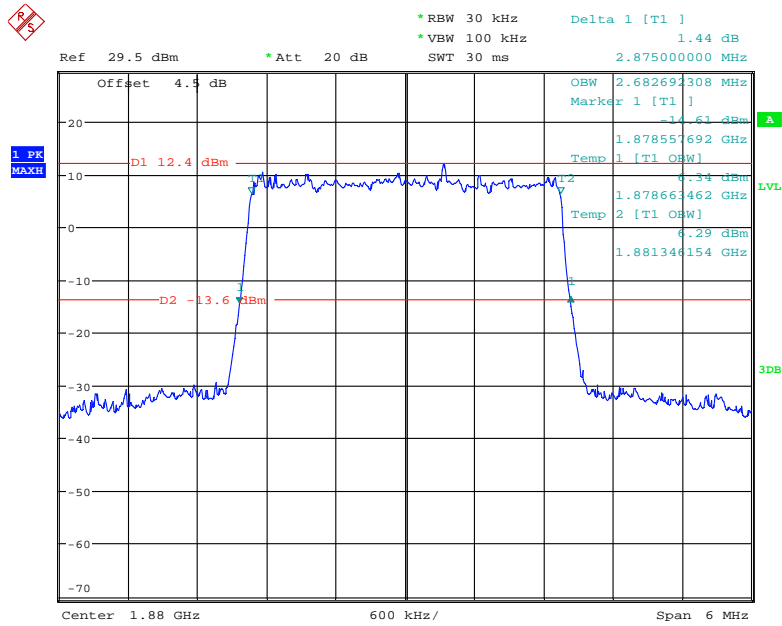

Date: 17.APR.2018 09:50:17

16-QAM (3.0 MHz) - 26 dB Bandwidth & 99% Occupied Bandwidth, Middle channel

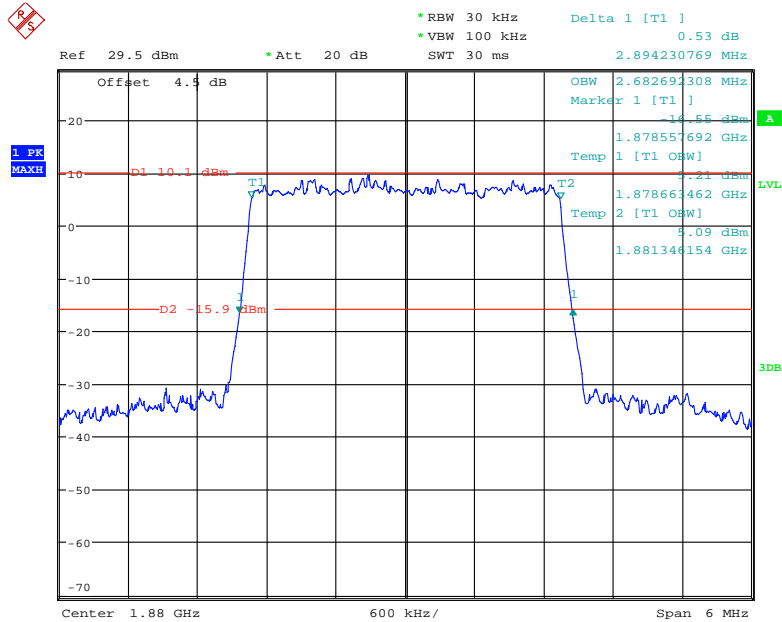

Date: 17.APR.2018 09:51:43

QPSK (5.0 MHz) - 26 dB Bandwidth & 99% Occupied Bandwidth, Middle channel

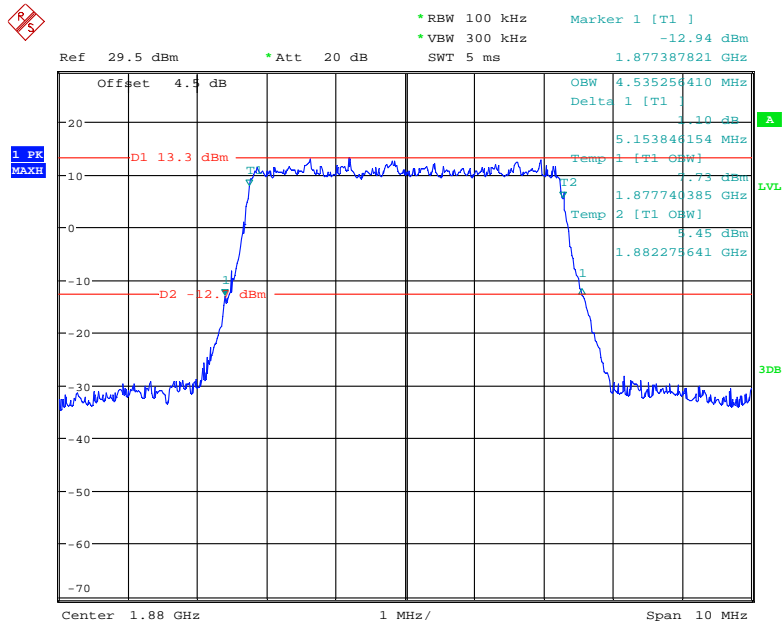

Date: 17.APR.2018 09:53:53

16-QAM (5.0 MHz) - 26 dB Bandwidth & 99% Occupied Bandwidth, Middle channel

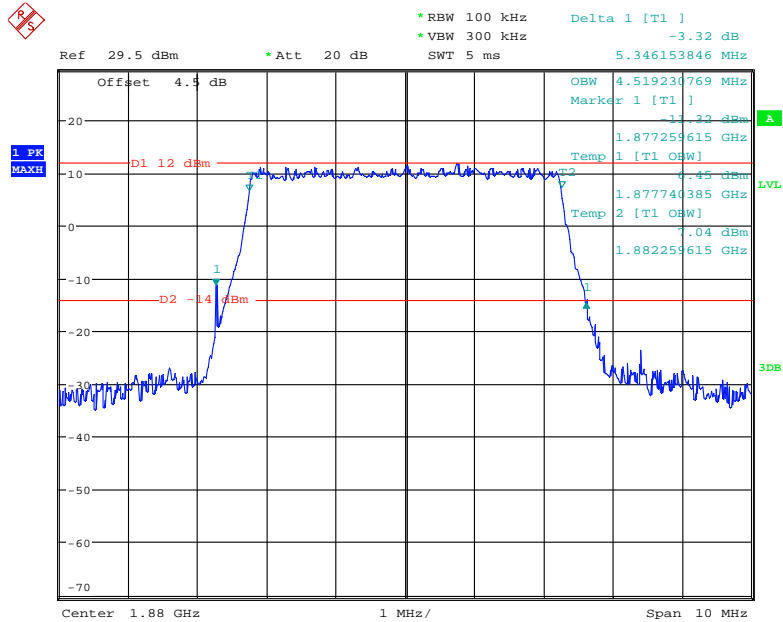

Date: 17.APR.2018 09:52:58

QPSK (10.0 MHz) - 26 dB Bandwidth & 99% Occupied Bandwidth, Middle channel

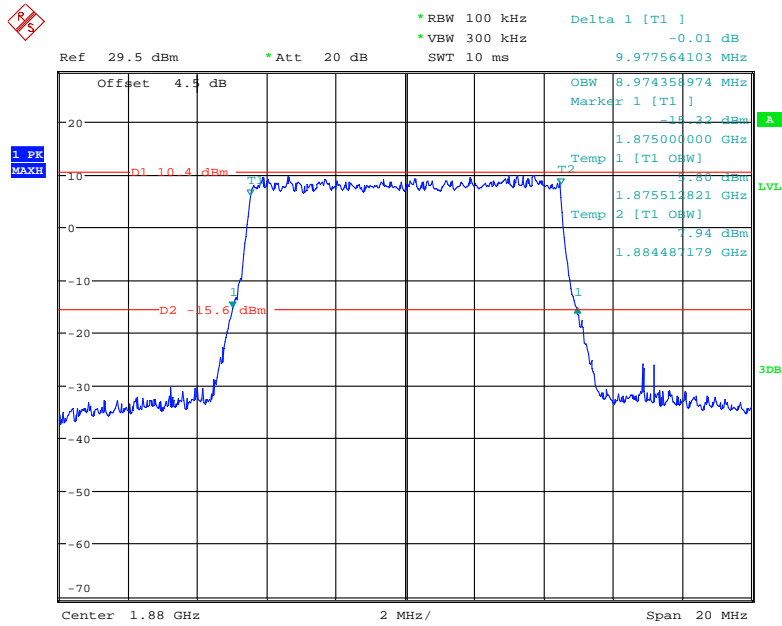

Date: 17.APR.2018 09:55:21

16-QAM (10.0 MHz) - 26 dB Bandwidth & 99% Occupied Bandwidth, Middle channel

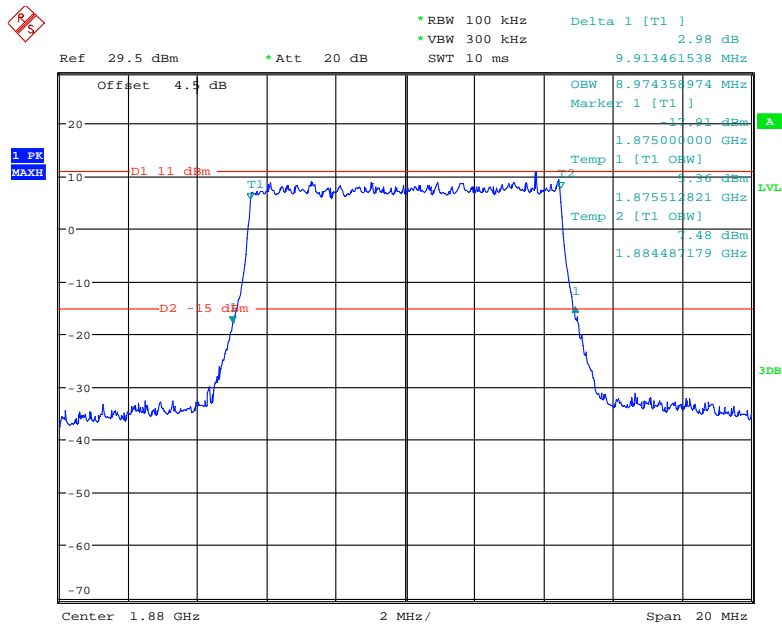

Date: 17.APR.2018 09:56:41

QPSK (15.0 MHz) - 26 dB Bandwidth & 99% Occupied Bandwidth, Middle channel

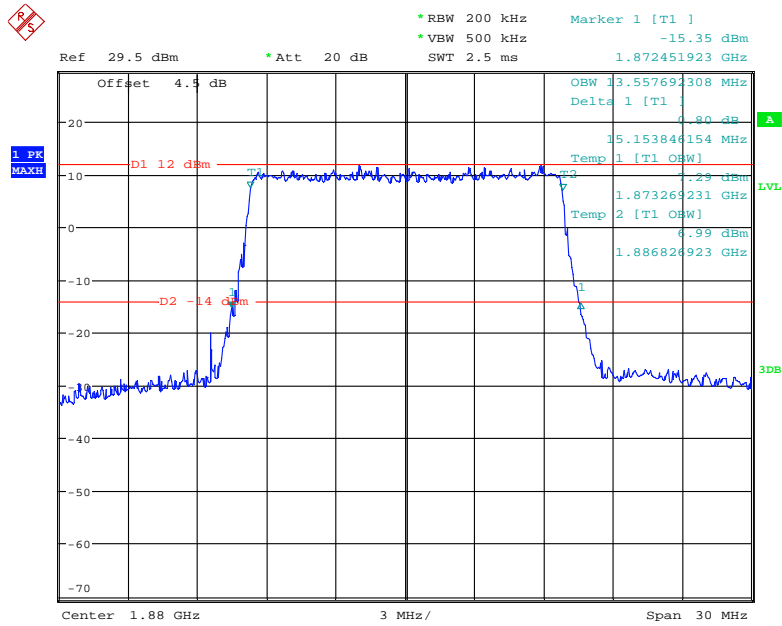

Date: 17.APR.2018 09:58:02

16-QAM (15.0 MHz) - 26 dB Bandwidth & 99% Occupied Bandwidth, Middle channel

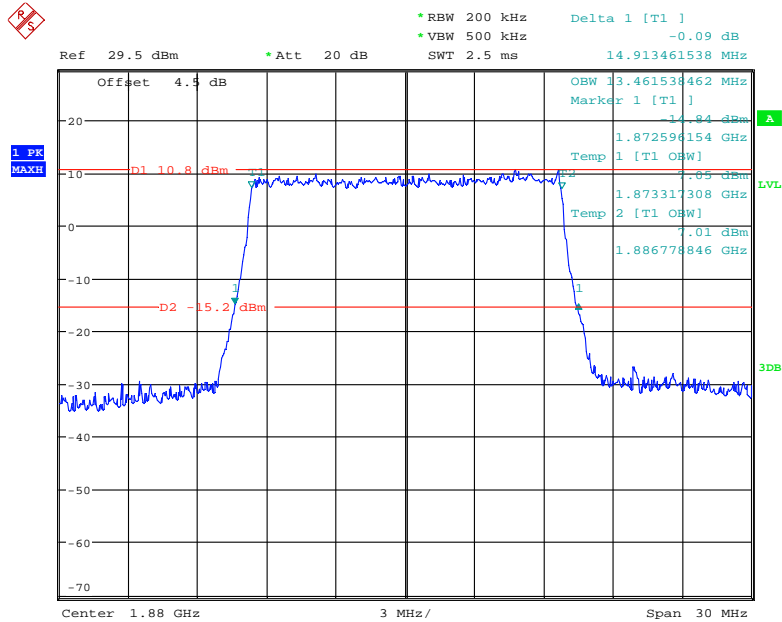

Date: 17.APR.2018 09:58:59

QPSK (20.0 MHz) - 26 dB Bandwidth & 99% Occupied Bandwidth, Middle channel

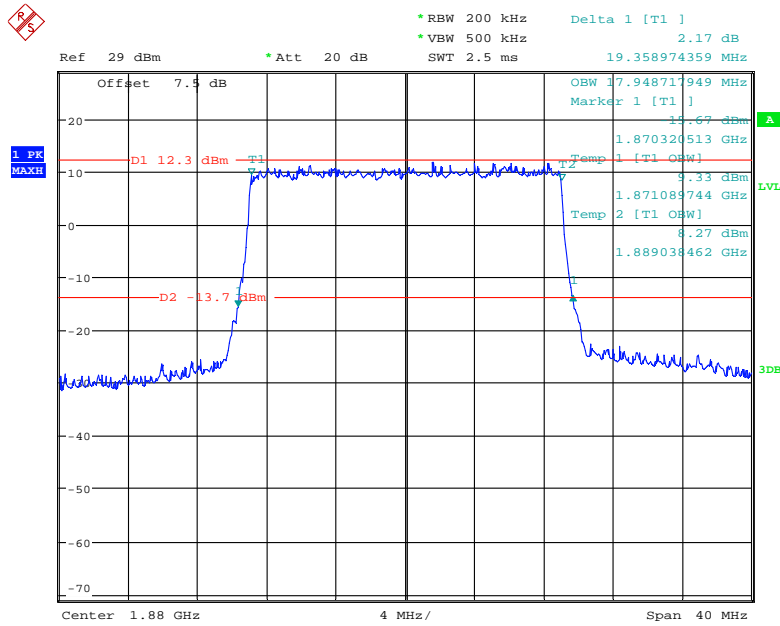

Date: 24.APR.2018 14:51:37

16-QAM (20.0 MHz) - 26 dB Bandwidth & 99% Occupied Bandwidth, Middle channel

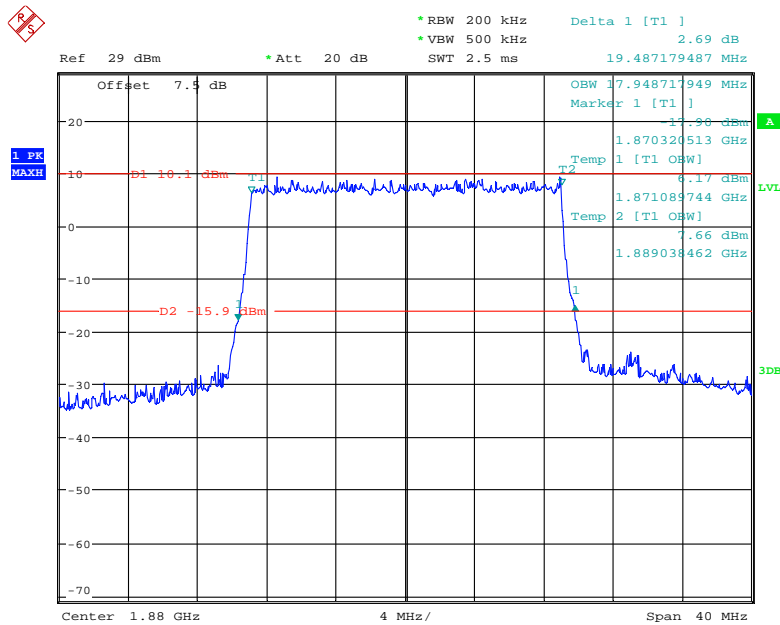

Date: 24.APR.2018 14:54:16

LTE Band 4: (Middle Channel)

Bandwidth (MHz)	Modulation	99% Occupied Bandwidth (MHz)	26 dB Emission Bandwidth (MHz)
1.4	QPSK	1.096	1.317
	16QAM	1.106	1.317
3.0	QPSK	2.692	2.875
	16QAM	2.692	2.875
5.0	QPSK	4.551	5.183
	16QAM	4.535	5.215
10.0	QPSK	8.947	10.000
	16QAM	8.974	9.776
15.0	QPSK	13.462	14.872
	16QAM	13.462	14.824
20.0	QPSK	17.821	19.247
	16QAM	17.949	19.311

QPSK (1.4 MHz) - 26 dB Bandwidth & 99% Occupied Bandwidth, Middle channel

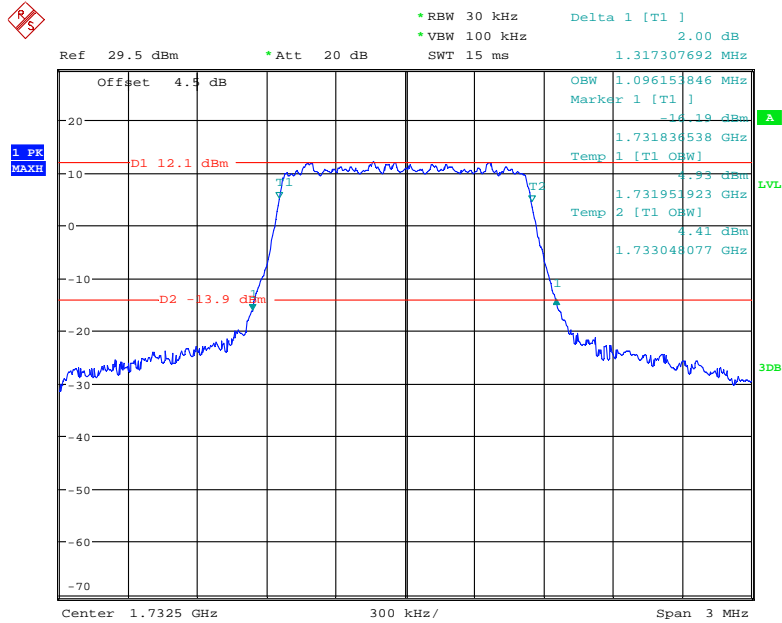

Date: 17.APR.2018 10:06:22

16-QAM (1.4 MHz) - 26 dB Bandwidth & 99% Occupied Bandwidth, Middle channel

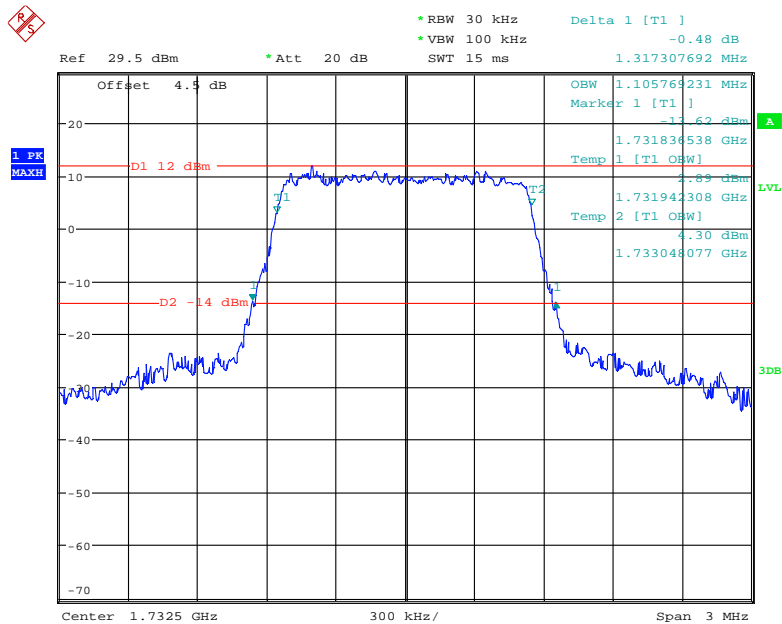

Date: 17.APR.2018 10:07:05

QPSK (3.0 MHz) - 26 dB Bandwidth & 99% Occupied Bandwidth, Middle channel

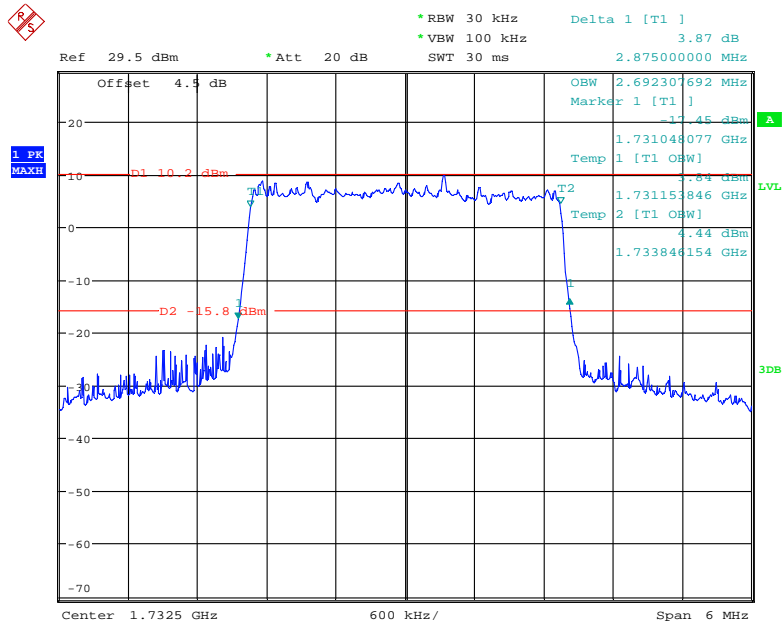

Date: 17.APR.2018 10:09:50

16-QAM (3.0 MHz) - 26 dB Bandwidth & 99% Occupied Bandwidth, Middle channel

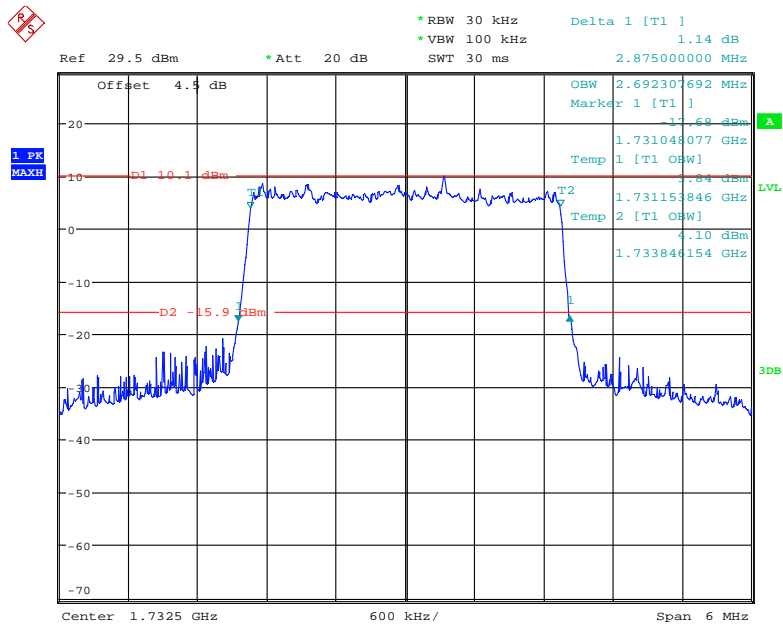

Date: 17.APR.2018 10:09:09

QPSK (5.0 MHz) - 26 dB Bandwidth & 99% Occupied Bandwidth, Middle channel

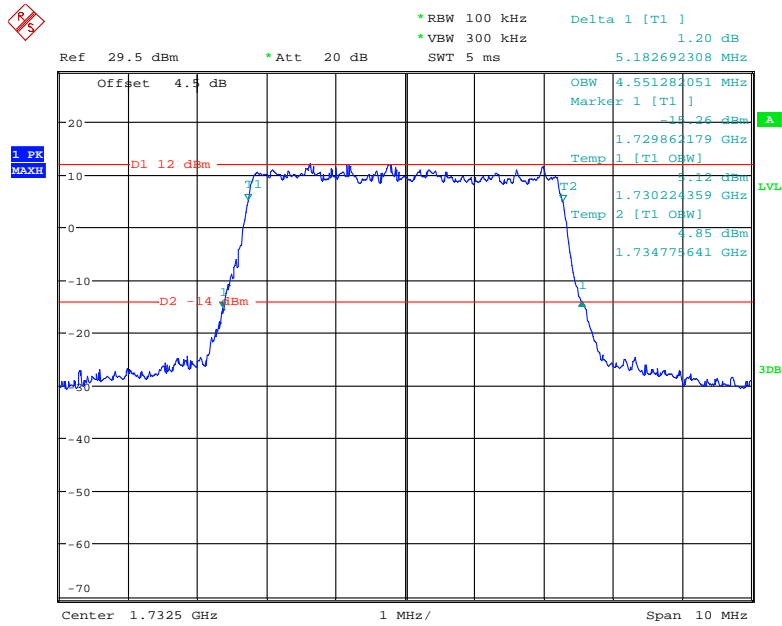

Date: 17.APR.2018 10:10:55

16-QAM (5.0 MHz) - 26 dB Bandwidth & 99% Occupied Bandwidth, Middle channel

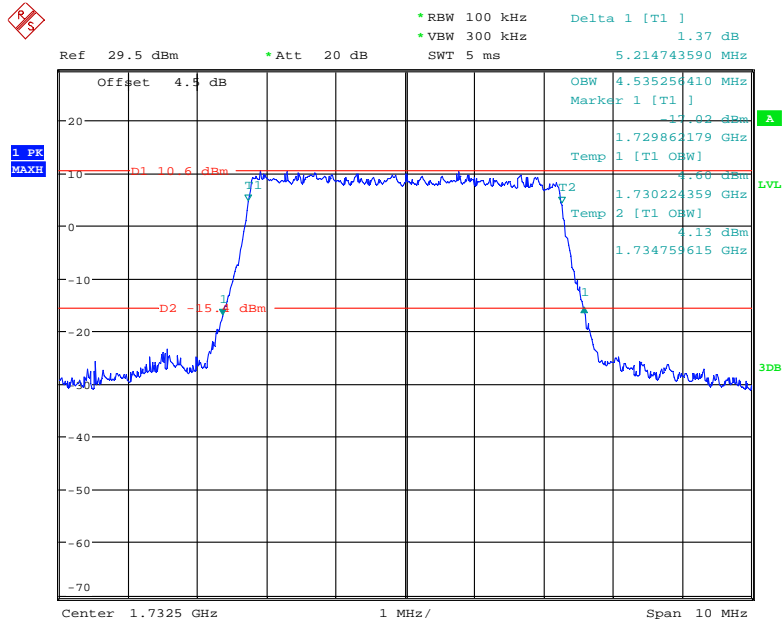

Date: 17.APR.2018 10:11:47

QPSK (10.0 MHz) - 26 dB Bandwidth & 99% Occupied Bandwidth, Middle channel

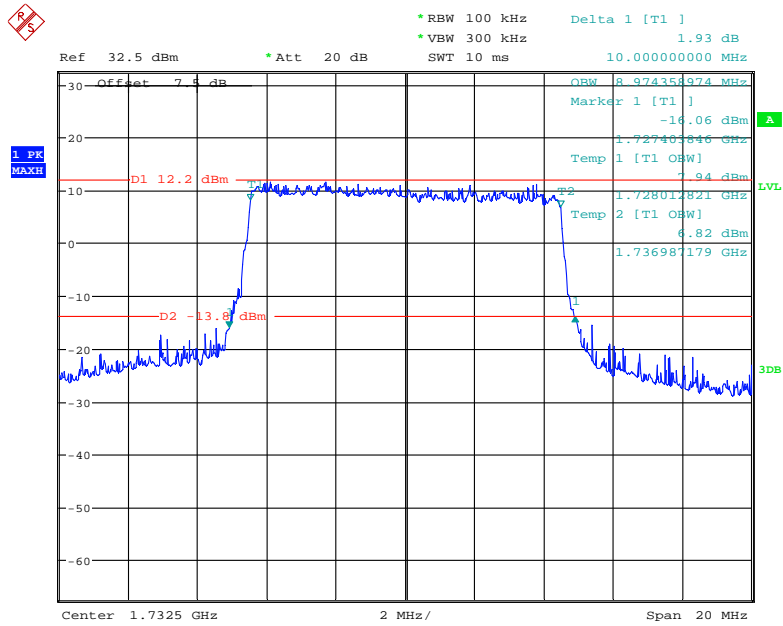

Date: 24.APR.2018 14:59:52

16-QAM (10.0 MHz) - 26 dB Bandwidth & 99% Occupied Bandwidth, Middle channel

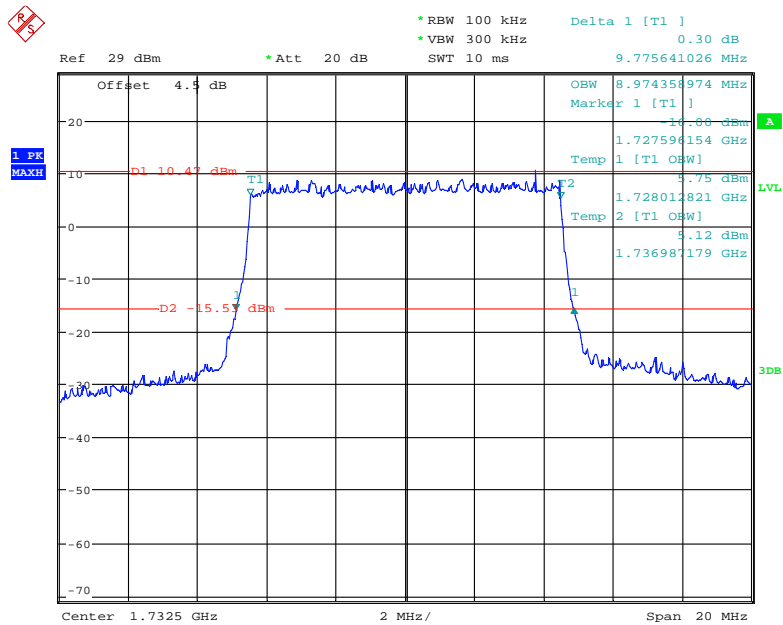

Date: 17.APR.2018 10:59:15

QPSK (15.0 MHz) - 26 dB Bandwidth & 99% Occupied Bandwidth, Middle channel

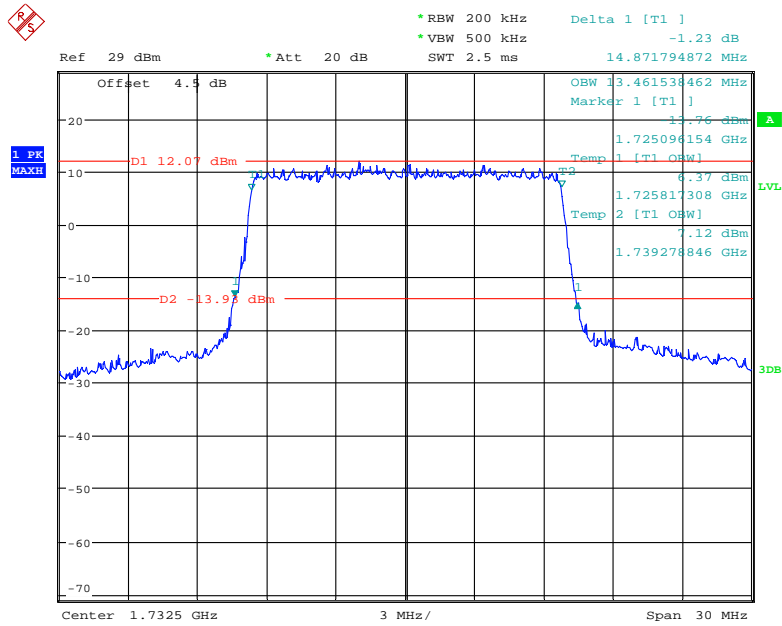

Date: 17.APR.2018 11:01:04

16-QAM (15.0 MHz) - 26 dB Bandwidth & 99% Occupied Bandwidth, Middle channel

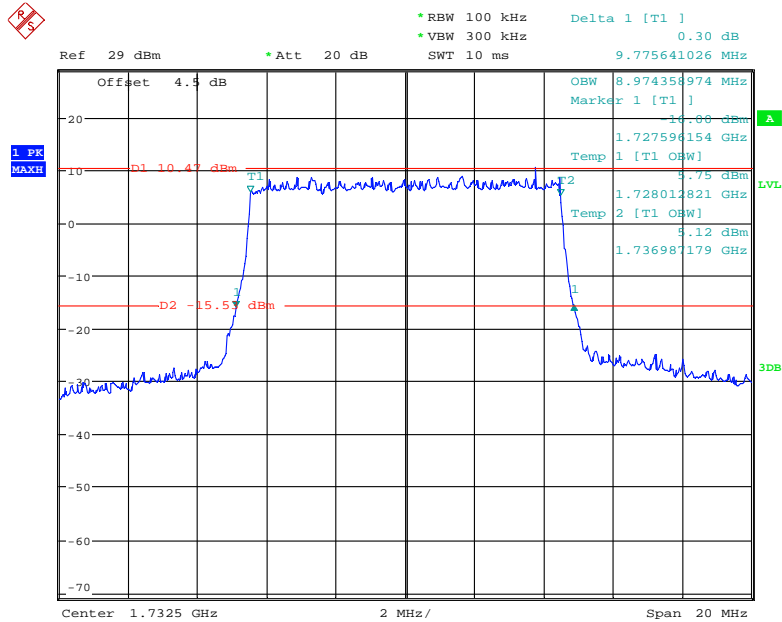

Date: 17.APR.2018 10:59:15

QPSK (20.0 MHz) - 26 dB Bandwidth & 99% Occupied Bandwidth, Middle channel

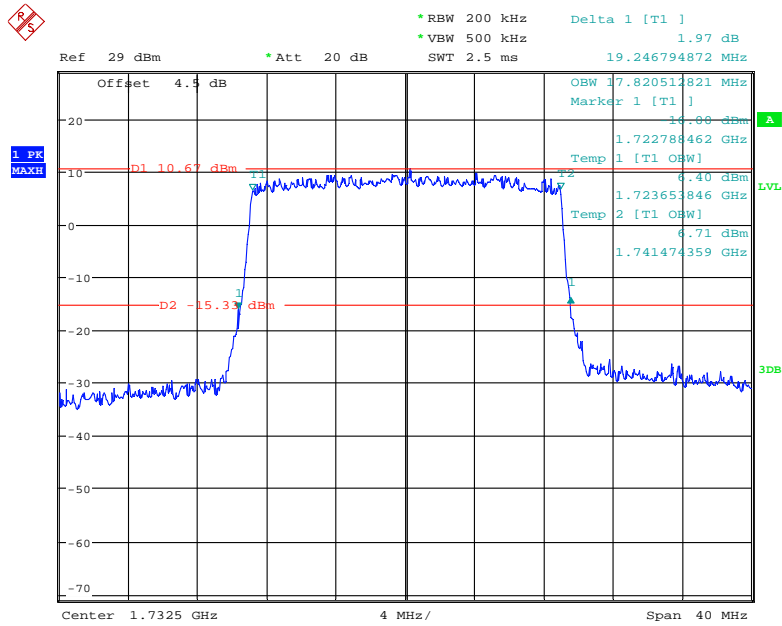

Date: 17.APR.2018 11:09:36

16-QAM (20.0 MHz) - 26 dB Bandwidth & 99% Occupied Bandwidth, Middle channel

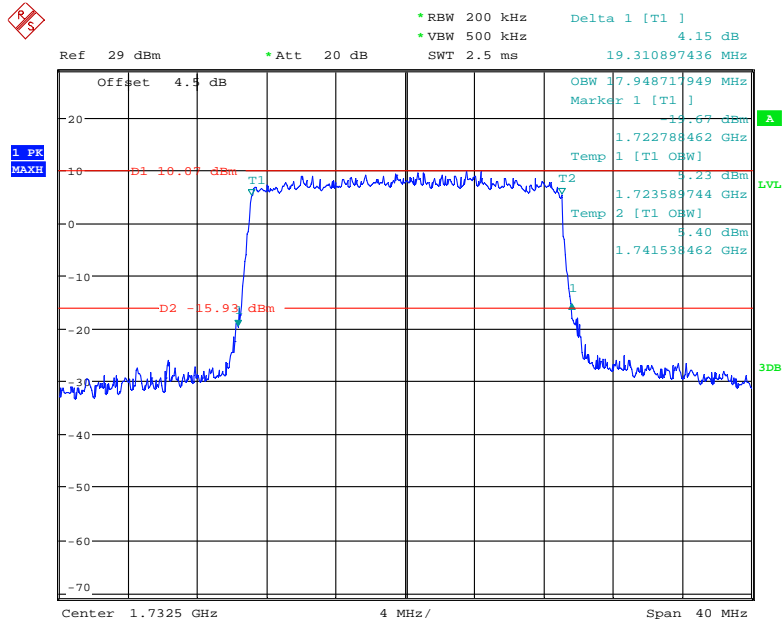

Date: 17.APR.2018 11:08:44

LTE Band 5: (Middle Channel)

Bandwidth (MHz)	Modulation	99% Occupied Bandwidth (MHz)	26 dB Emission Bandwidth (MHz)
1.4	QPSK	1.115	1.356
	16QAM	1.111	1.332
3.0	QPSK	2.702	2.952
	16QAM	2.702	2.995
5.0	QPSK	4.535	5.056
	16QAM	4.519	5.072
10.0	QPSK	8.974	9.896
	16QAM	8.974	9.736

QPSK (1.4 MHz) - 26 dB Emissions & 99% Occupied Bandwidth, Middle channel

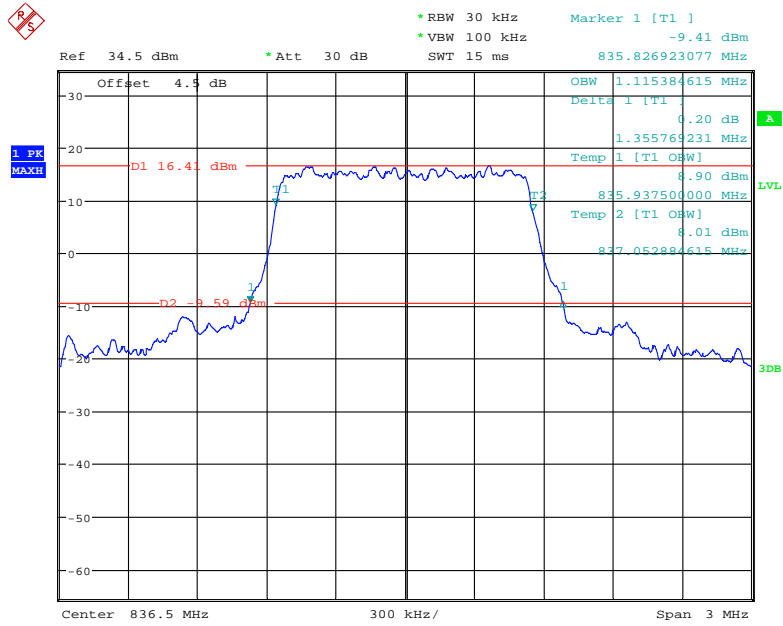

Date: 15.MAY.2018 19:18:24

16-QAM (1.4 MHz) -26 dB Emissions & 99% Occupied Bandwidth, Middle channel

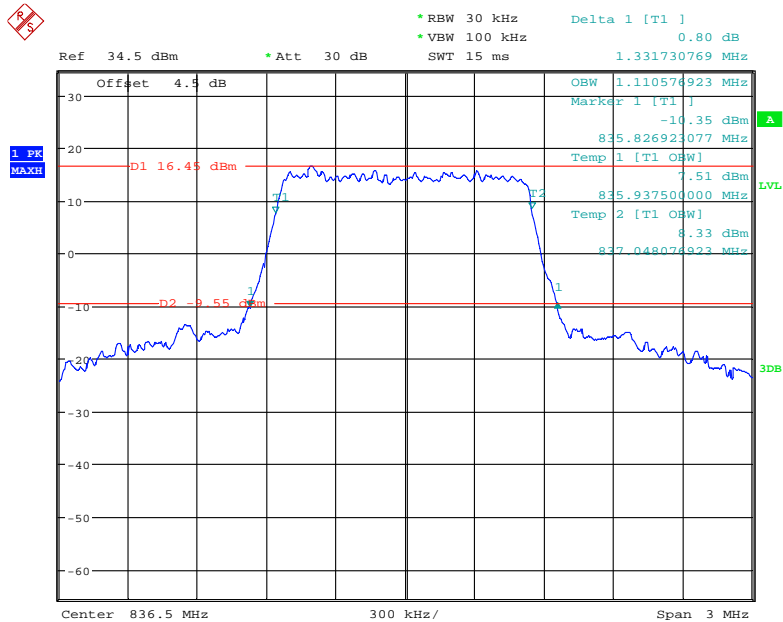

Date: 15.MAY.2018 19:20:34

QPSK (3.0 MHz) - 26 dB Emissions & 99% Occupied Bandwidth, Middle channel

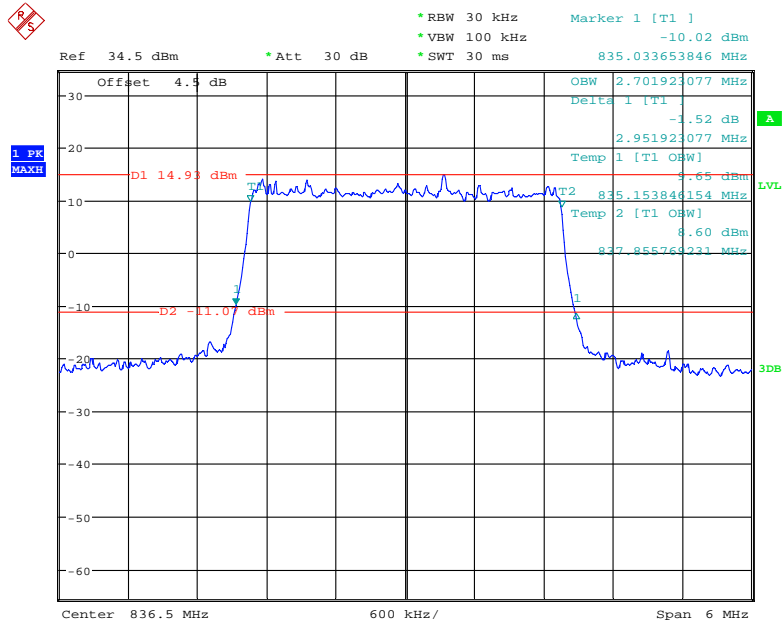

Date: 15.MAY.2018 19:27:11

16-QAM (3.0 MHz) - 26 dB Emissions & 99% Occupied Bandwidth, Middle channel

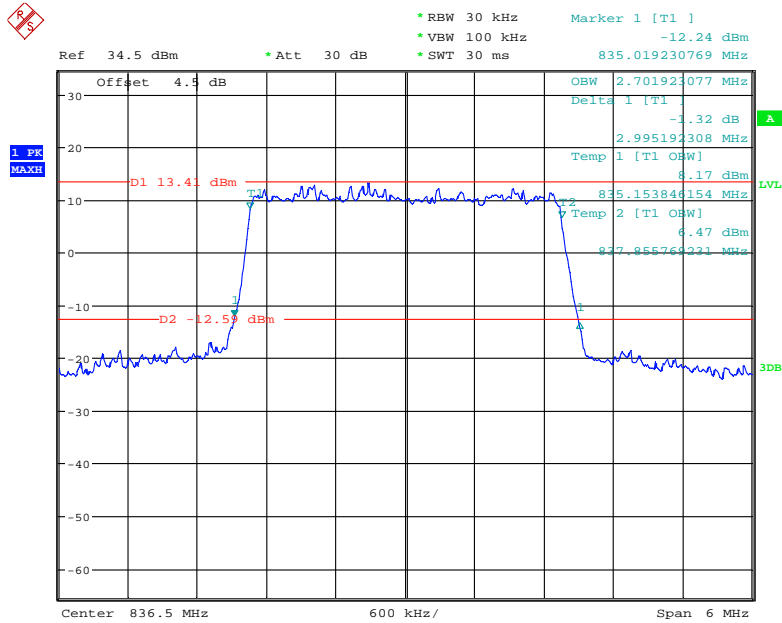

Date: 15.MAY.2018 19:30:23

QPSK (5.0 MHz) - 26 dB Emissions & 99% Occupied Bandwidth, Middle channel

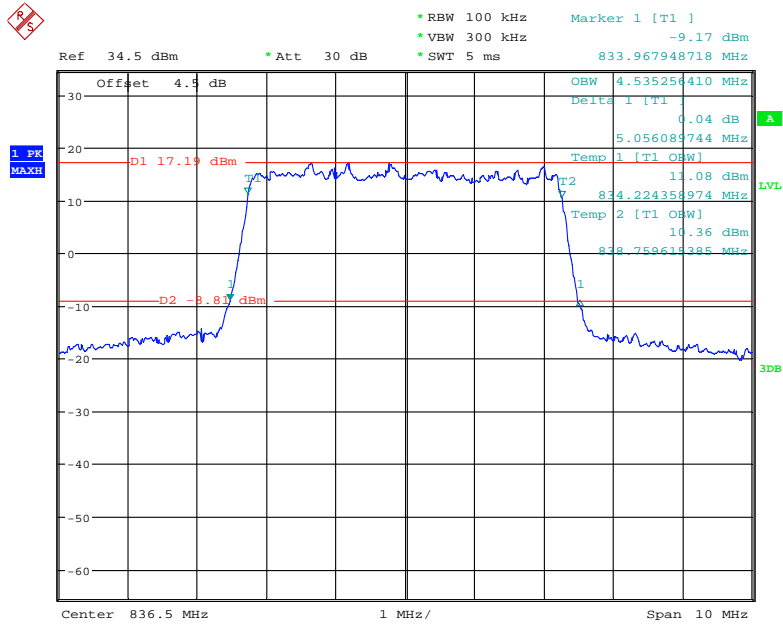

Date: 15.MAY.2018 19:35:02

16-QAM (5.0 MHz) - 26 dB Emissions & 99% Occupied Bandwidth, Middle channel

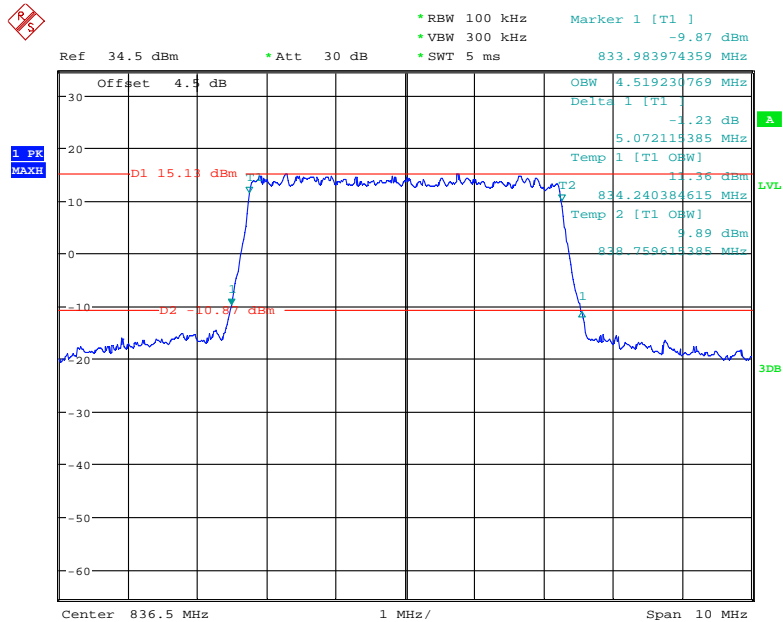

Date: 15.MAY.2018 19:38:30

QPSK (10.0 MHz) - 26 dB Emissions & 99% Occupied Bandwidth, Middle channel

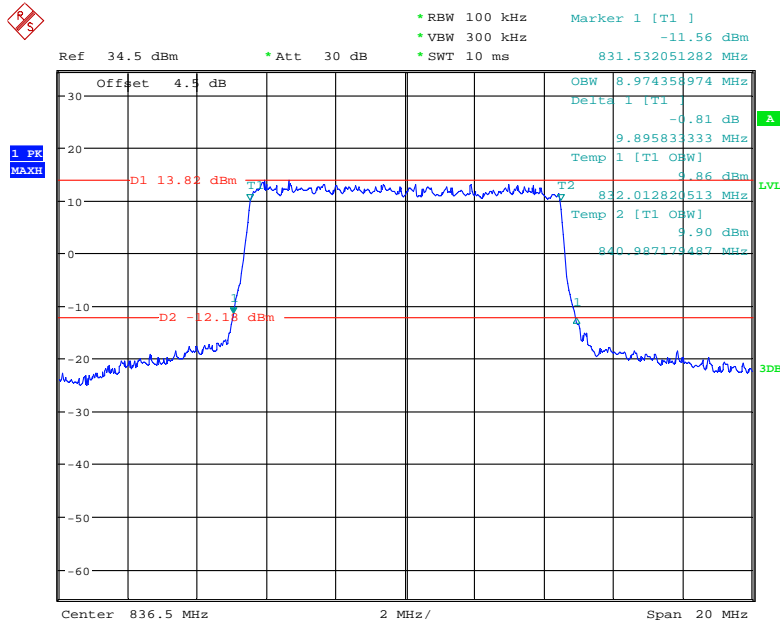

Date: 15.MAY.2018 19:42:29

16-QAM (10.0 MHz) - 26 dB Emissions & 99% Occupied Bandwidth, Middle channel

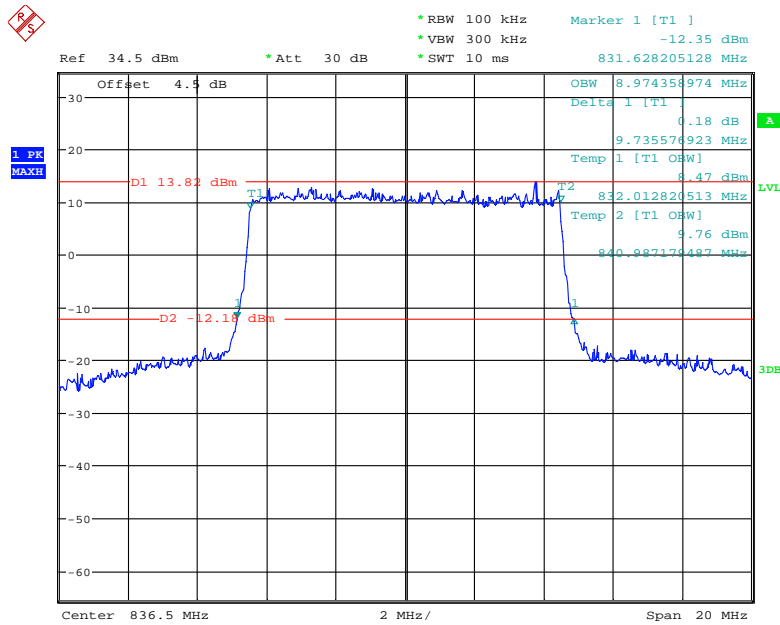

Date: 15.MAY.2018 19:44:23

LTE BAND 7:

Bandwidth (MHz)	Modulation	99% Occupied Bandwidth (MHz)	26 dB Emission Bandwidth (MHz)
5.0	QPSK	4.551	5.160
	16QAM	4.551	5.192
10.0	QPSK	8.947	10.032
	16QAM	8.947	10.032
15.0	QPSK	13.510	15.272
	16QAM	13.462	14.888
20.0	QPSK	17.885	19.311
	16QAM	18.013	19.696

QPSK (5.0 MHz) - 26 dB Emissions & 99% Occupied Bandwidth, Middle channel

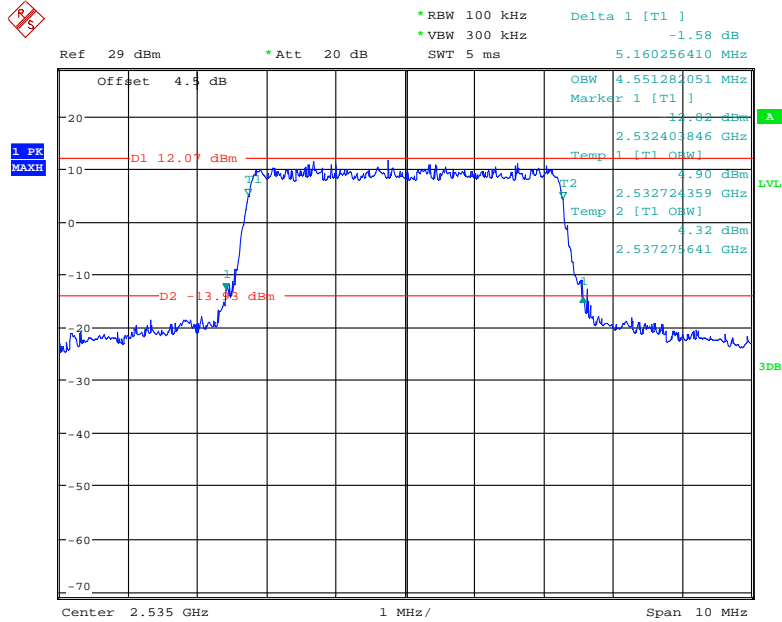

Date: 17.APR.2018 11:28:20

16-QAM (5.0 MHz) - 26 dB Emissions & 99% Occupied Bandwidth, Middle channel

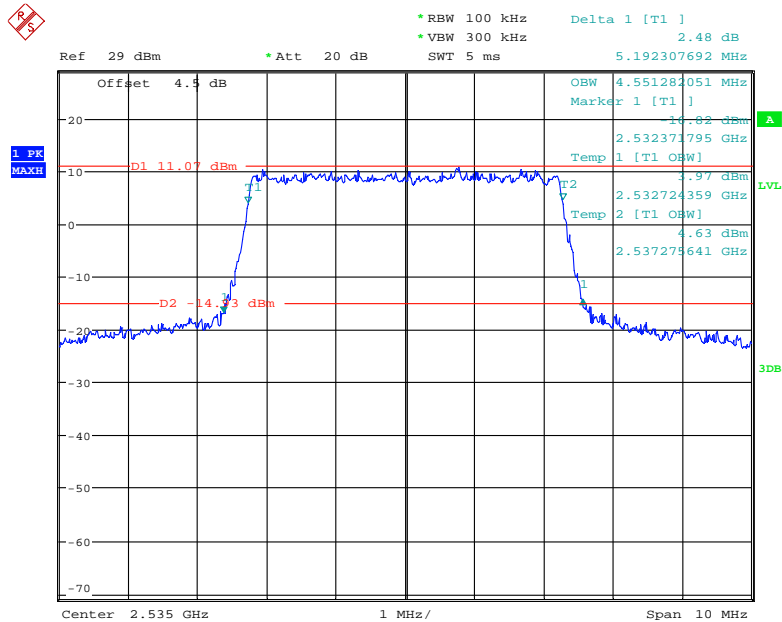

Date: 17.APR.2018 11:26:59

QPSK (10.0 MHz) - 26 dB Emissions & 99% Occupied Bandwidth, Middle channel

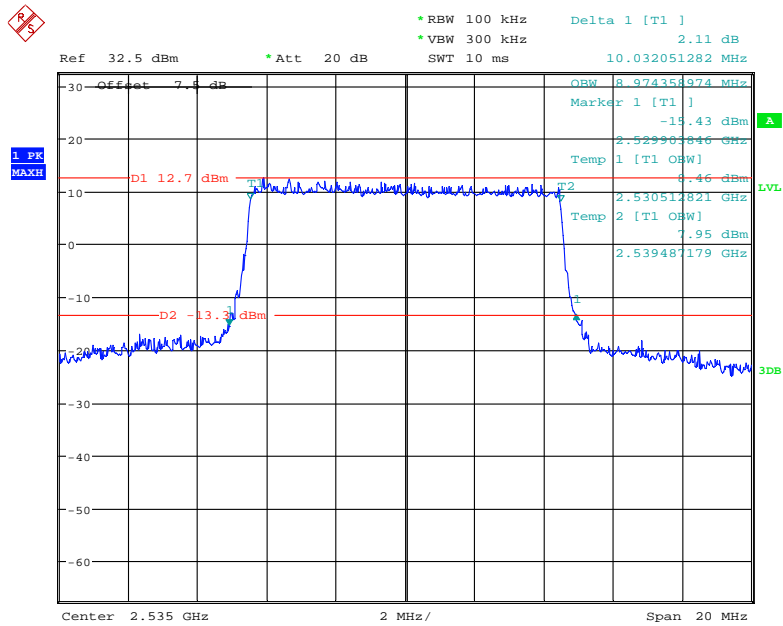

Date: 24.APR.2018 15:04:16

16-QAM (10.0 MHz) - 26 dB Emissions & 99% Occupied Bandwidth, Middle channel

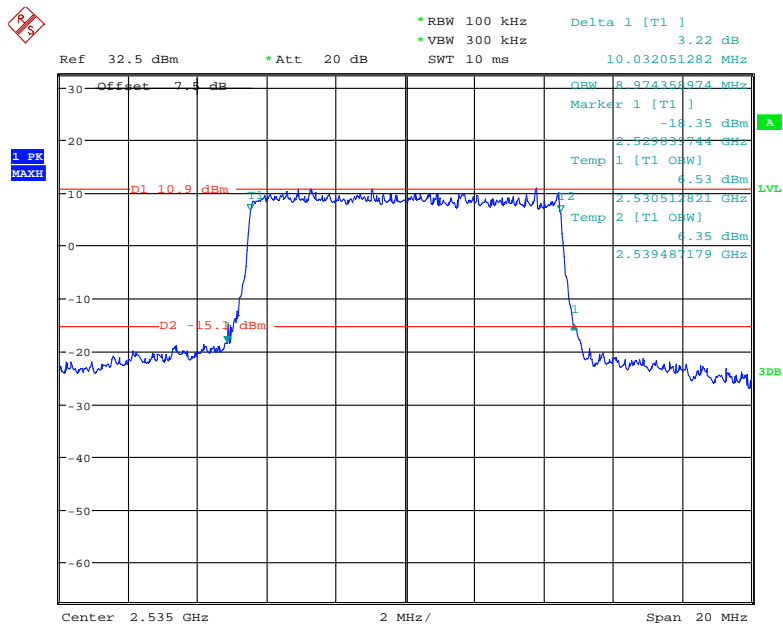

Date: 24.APR.2018 15:02:55

QPSK (15.0 MHz) - 26 dB Emissions & 99% Occupied Bandwidth, Middle channel

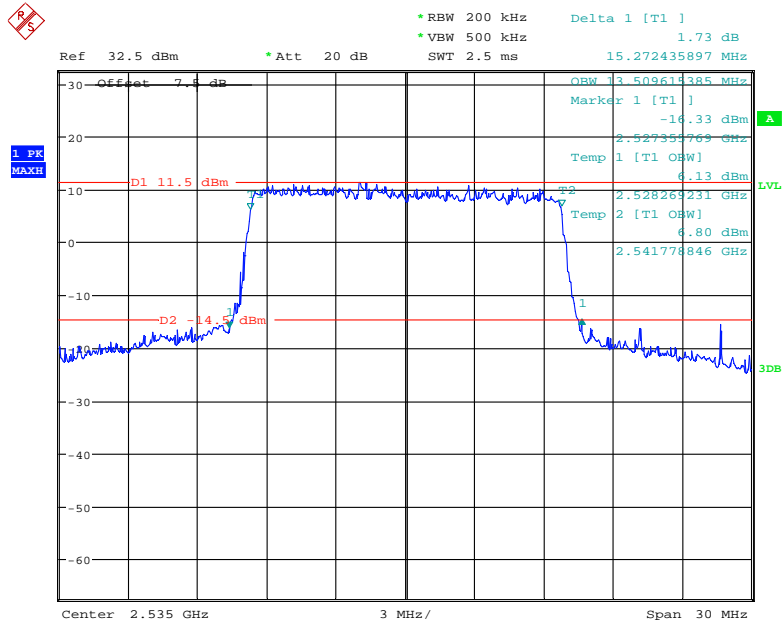

Date: 24.APR.2018 15:07:01

16-QAM (15.0 MHz) - 26 dB Emissions & 99% Occupied Bandwidth, Middle channel

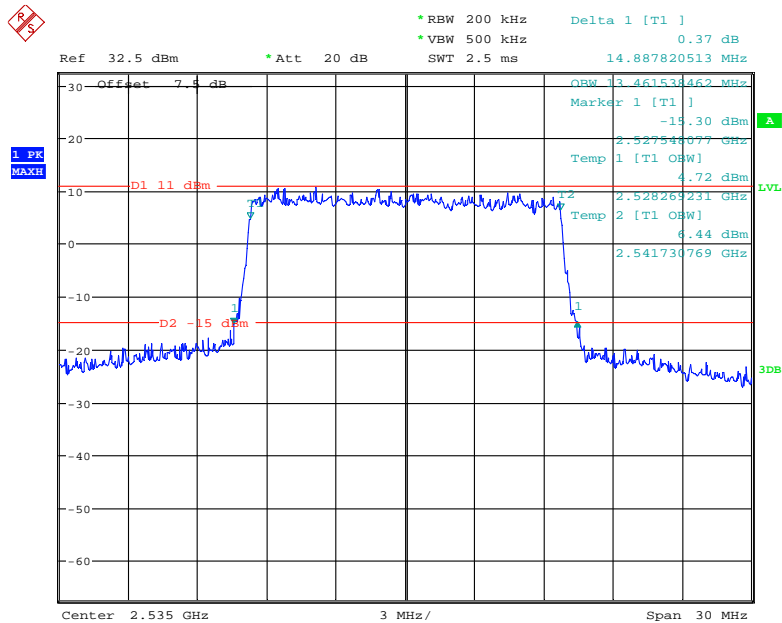

Date: 24.APR.2018 15:05:39

QPSK (20.0 MHz) - 26 dB Emissions & 99% Occupied Bandwidth, Middle channel

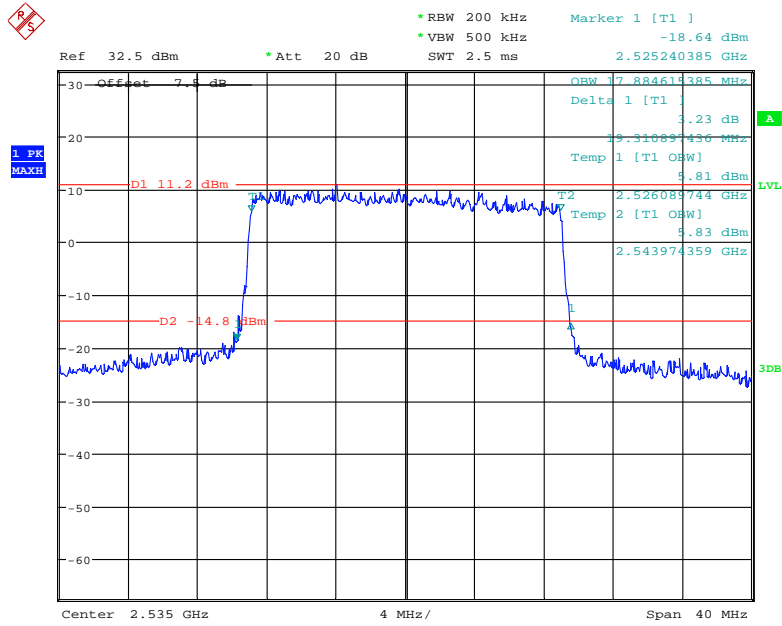

Date: 24.APR.2018 15:11:20

16-QAM (20.0 MHz) - 26 dB Emissions & 99% Occupied Bandwidth, Middle channel

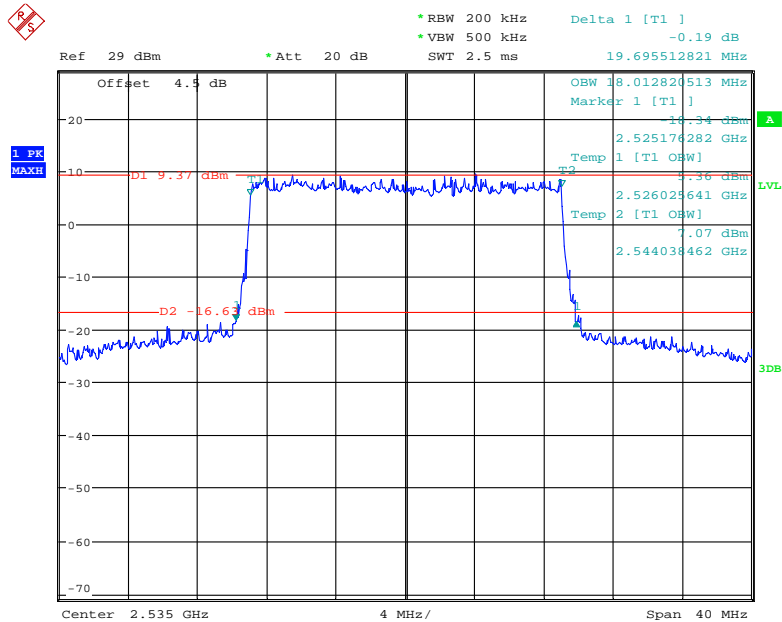

Date: 17.APR.2018 11:42:46

FCC §2.1051, §22.917(a) & §24.238(a); §27.53 (h) (m) - SPURIOUS EMISSIONS AT ANTENNA TERMINALS

Applicable Standard

FCC §2.1051, §22.917(a) and §24.238(a) and §27.53(h) (m).

The spectrum was to be investigated to the tenth harmonics of the highest fundamental frequency as specified in § 2.1051.

Test Procedure

The RF output of the transceiver was connected to a spectrum analyzer and simulator through appropriate attenuation. The resolution bandwidth of the spectrum analyzer was set at 1MHz. Sufficient scans were taken to show any out of band emissions up to 10th harmonic.

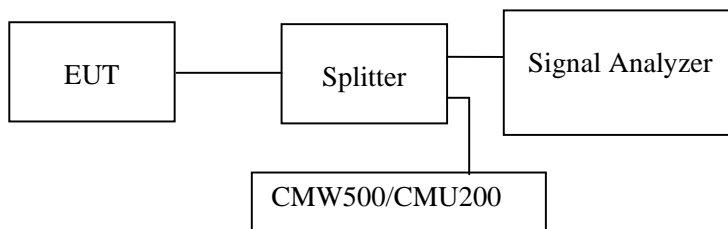

Test Data

Environmental Conditions

Temperature:	25~26 °C
Relative Humidity:	52~54 %
ATM Pressure:	101.0 kPa

The testing was performed by Tracy Hu from 2018-04-14 to 2018-04-24.

Test result: Compliance.

EUT operation mode: transmitting

Please refer to the following plots.

Cellular Band (Part 22H)

30 MHz – 1 GHz (GSM Mode)

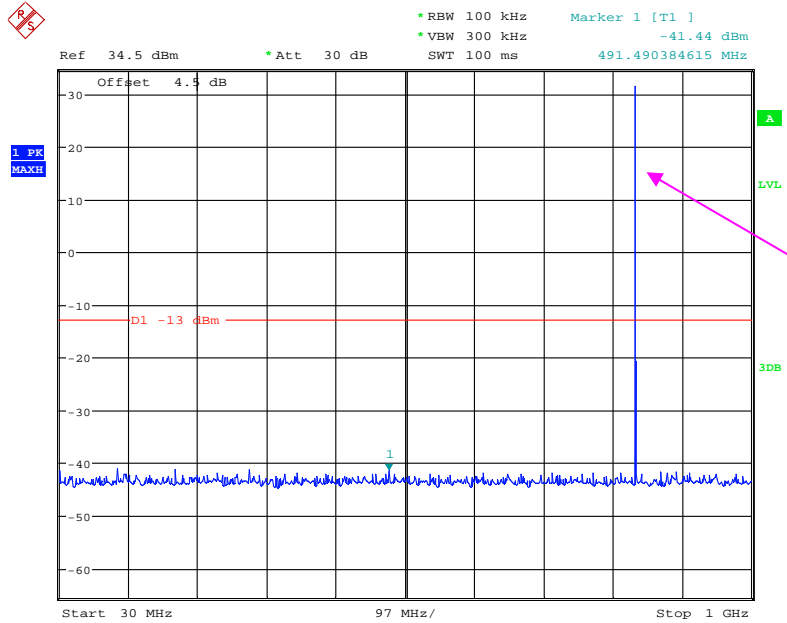

Fundamental test

1 GHz – 10 GHz (GSM Mode)

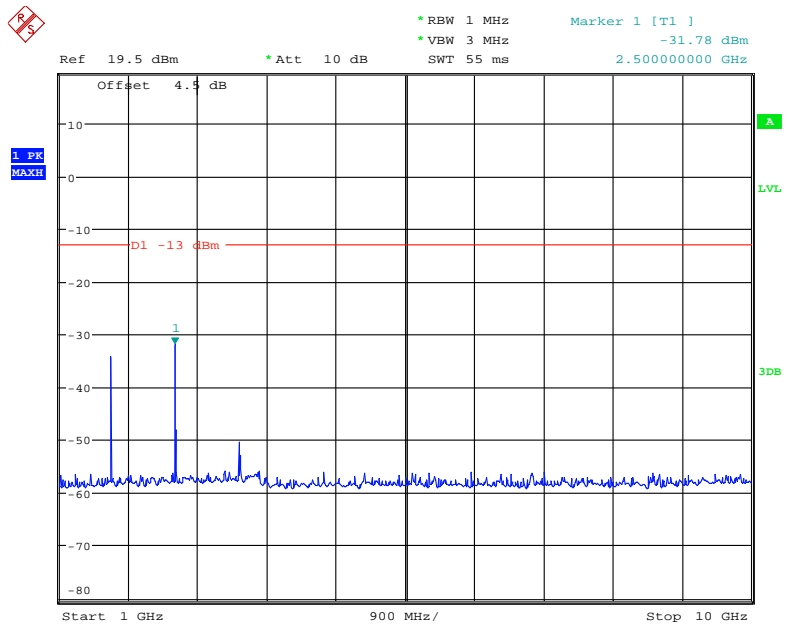

Date: 14.APR.2018 11:14:18

30 MHz – 1 GHz (WCDMA Mode)

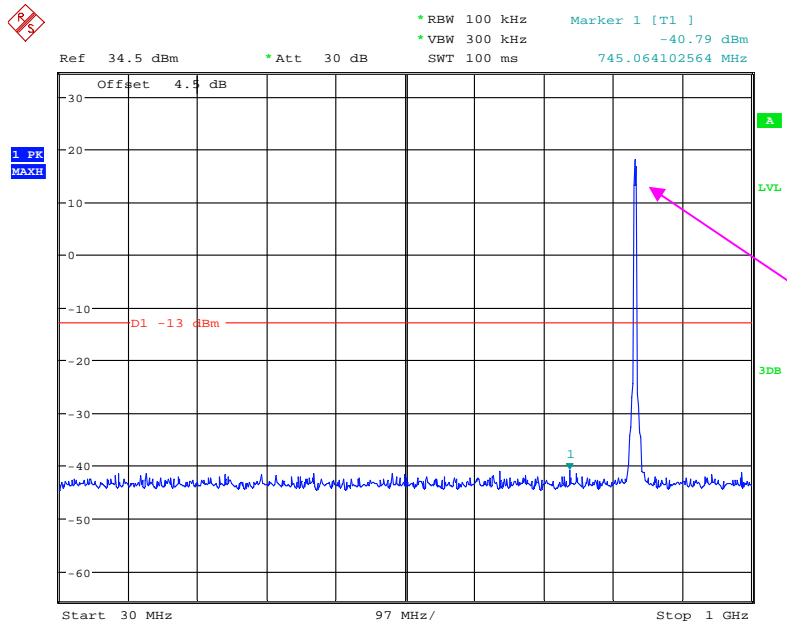

Date: 14.APR.2018 14:19:14

1 GHz – 10 GHz (WCDMA Mode)

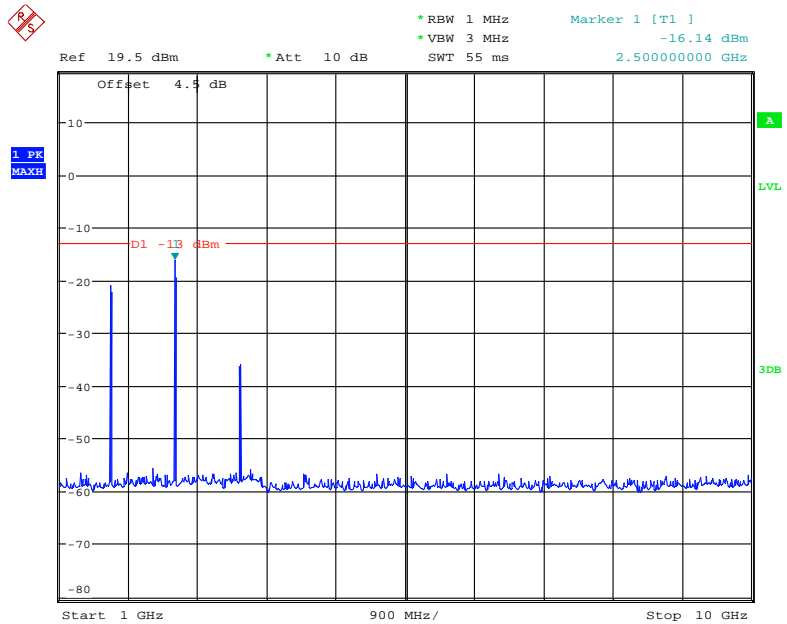

Date: 14.APR.2018 14:18:31

PCS Band (Part 24E)

30 MHz – 1 GHz (GSM Mode)

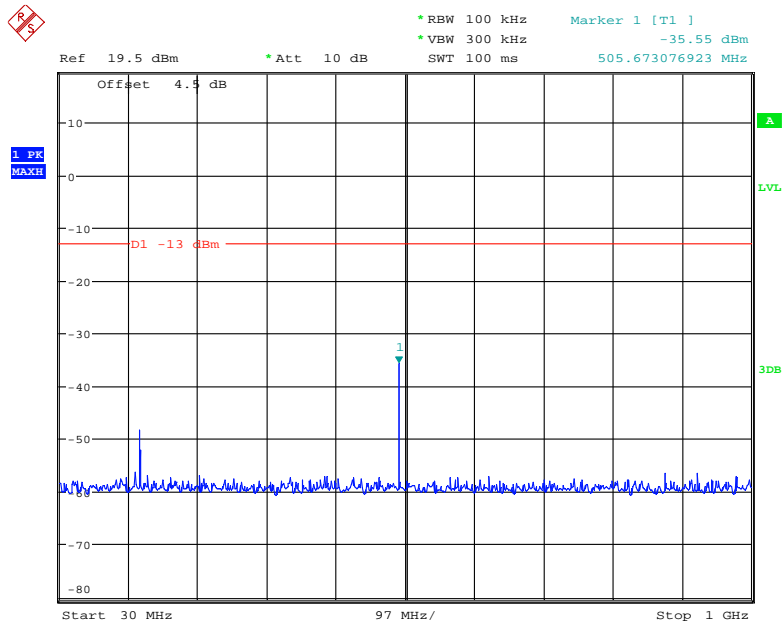

Date: 14.APR.2018 11:23:37

1 GHz – 2 GHz (GSM Mode)

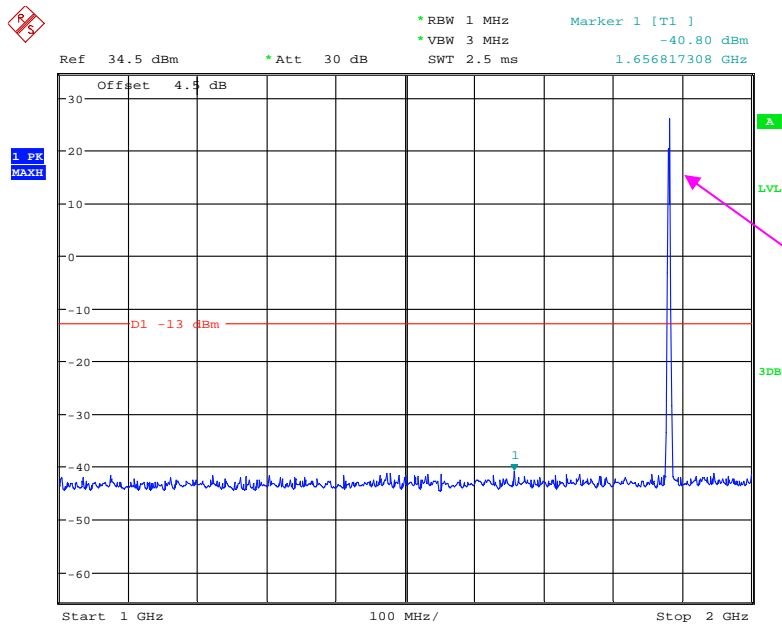

Date: 14.APR.2018 11:22:12

2 GHz – 20 GHz (GSM Mode)

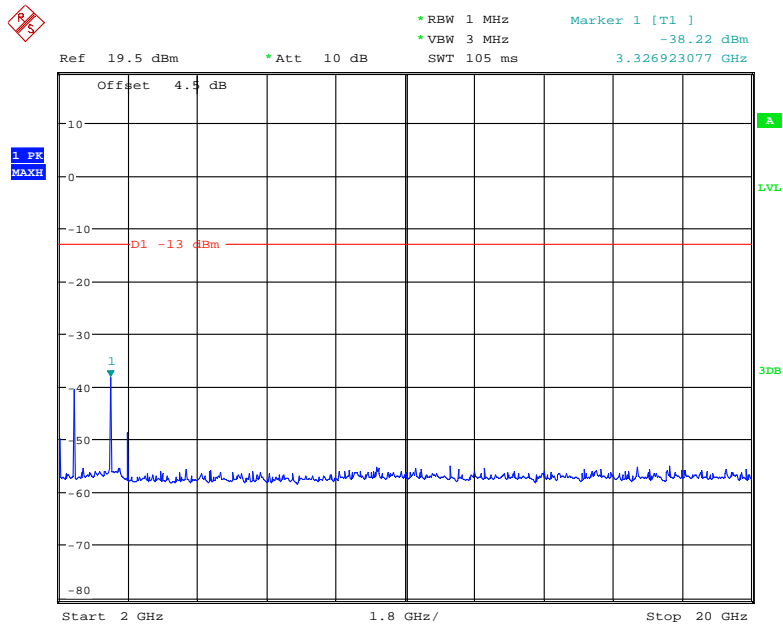

Date: 14.APR.2018 11:23:07

30 MHz – 1 GHz (WCDMA Mode)

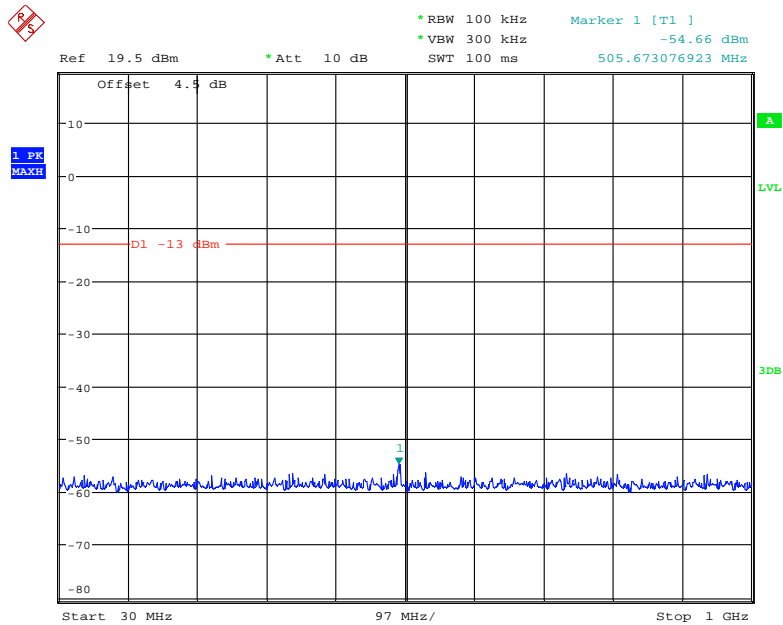

Date: 14.APR.2018 14:15:54

1 GHz – 2 GHz (WCDMA Mode)

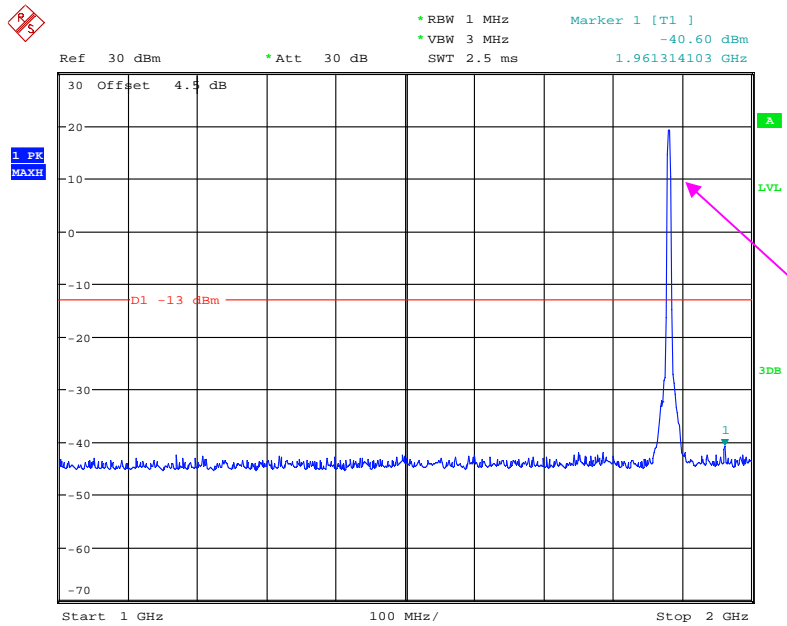

Date: 14.APR.2018 14:14:22

2 GHz – 20 GHz (WCDMA Mode)

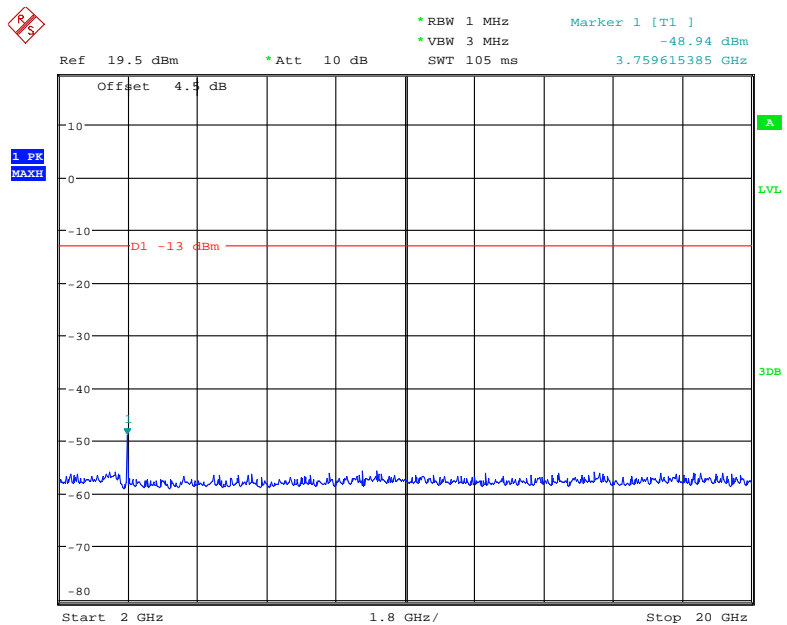

Date: 14.APR.2018 14:15:04

LTE Band 2:

30 MHz - 1 GHz (1.4 MHz, Middle Channel)

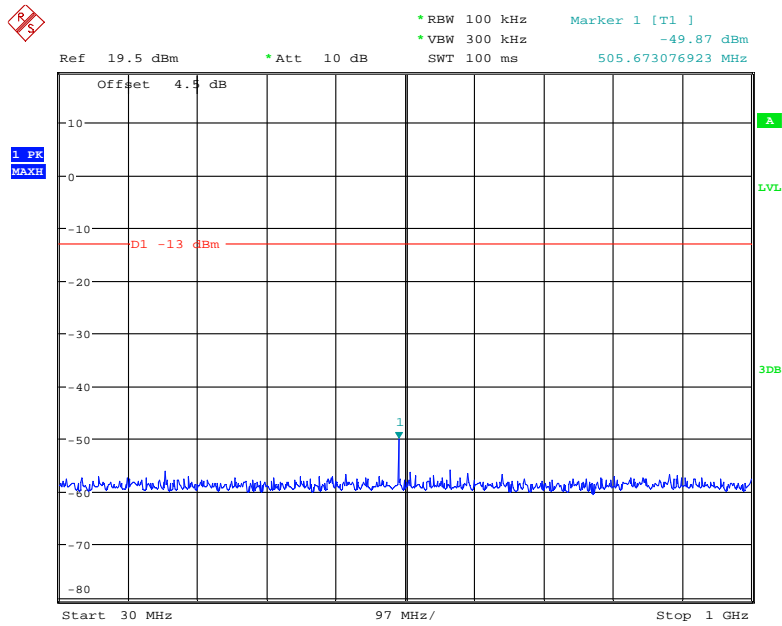

Date: 18.APR.2018 11:29:04

1 GHz - 2 GHz (1.4 MHz, Middle Channel)

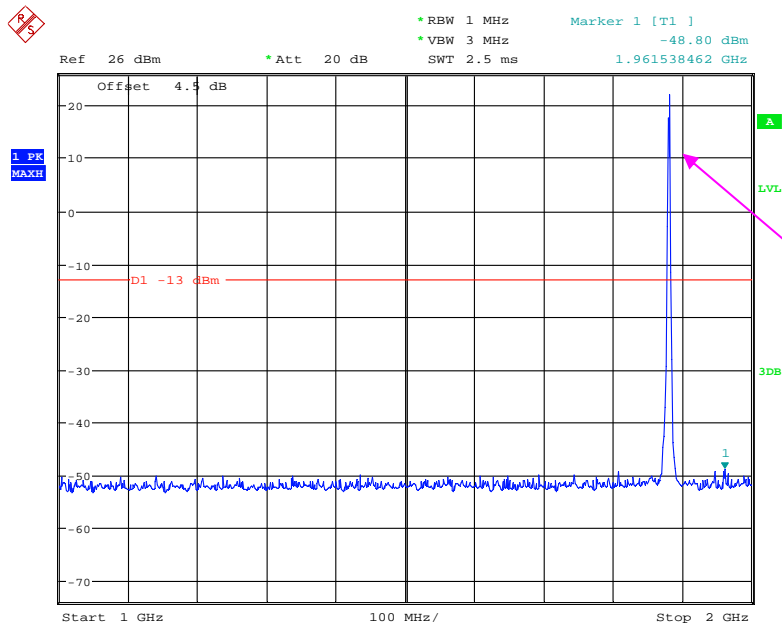

Date: 18.APR.2018 11:14:02

2 GHz – 20 GHz (1.4 MHz, Middle Channel)

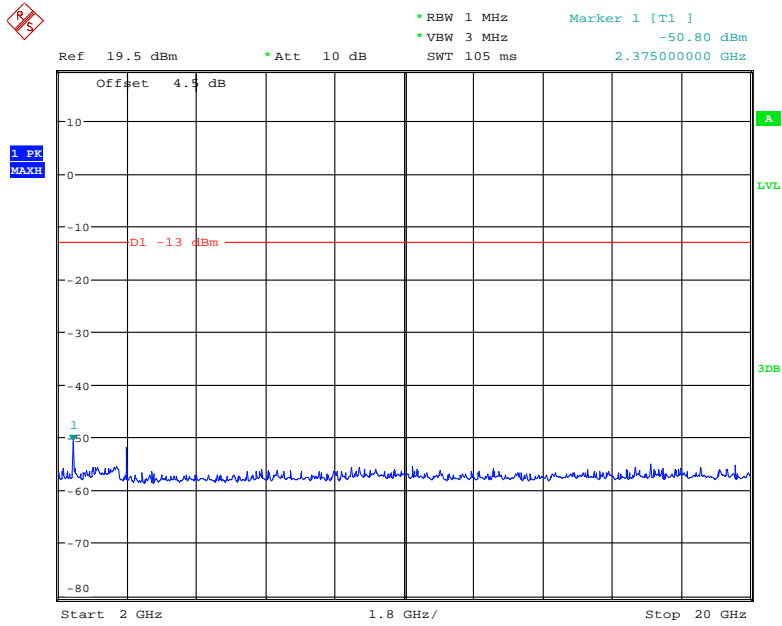

Date: 18.APR.2018 11:25:05

30 MHz - 1 GHz (3.0 MHz, Middle Channel)

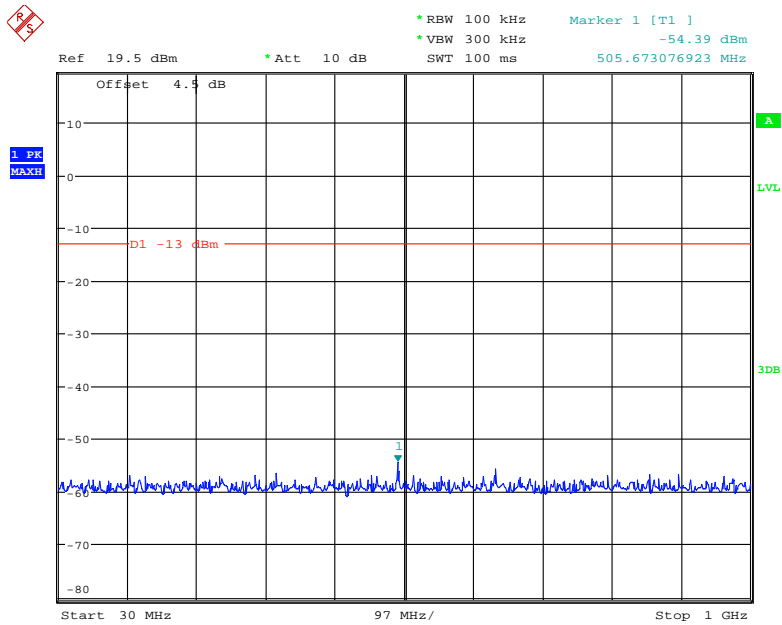

Date: 18.APR.2018 11:29:33

1 GHz – 2 GHz (3.0 MHz, Middle Channel)

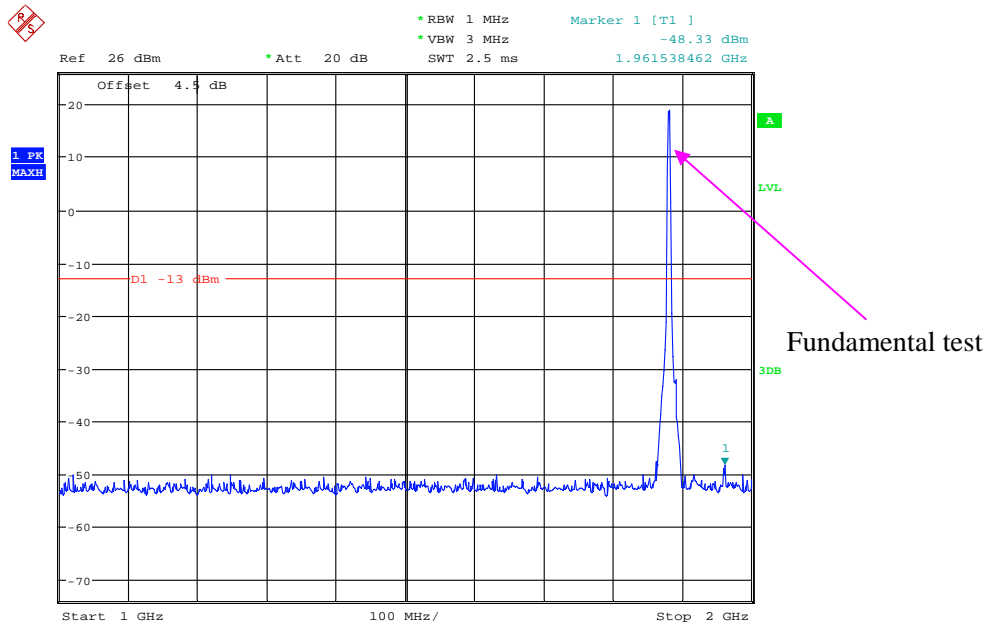

Date: 18.APR.2018 11:14:50

2 GHz – 20 GHz (3.0 MHz, Middle Channel)

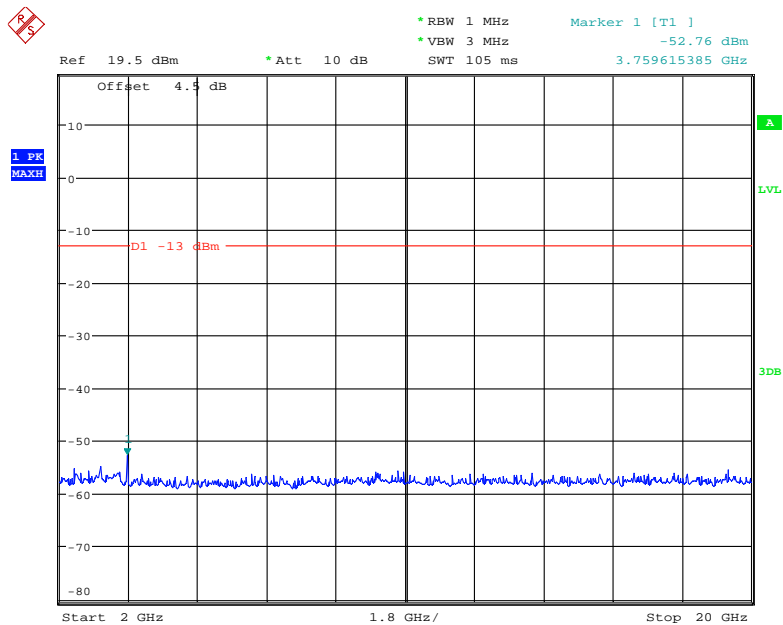

Date: 18.APR.2018 11:25:32

30 MHz - 1 GHz (5.0 MHz, Middle Channel)

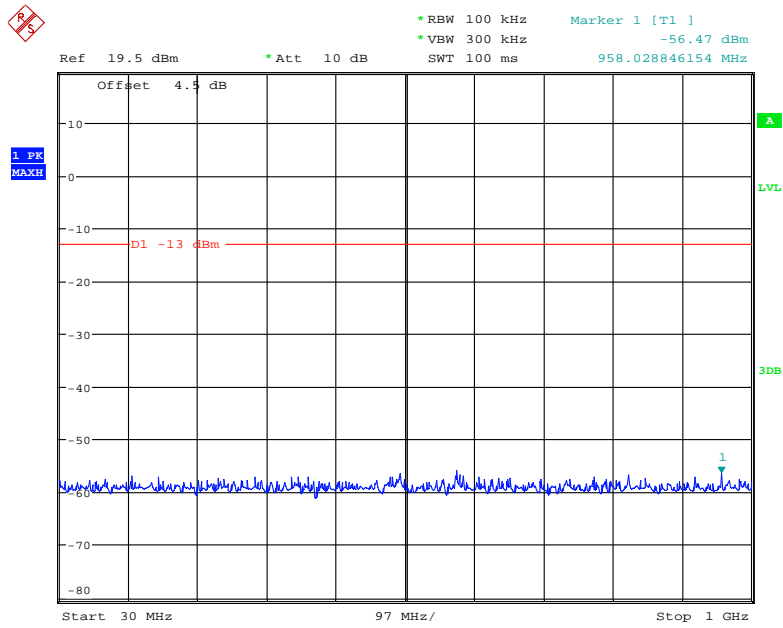

Date: 18.APR.2018 11:30:17

1 GHz - 2 GHz (5.0 MHz, Middle Channel)

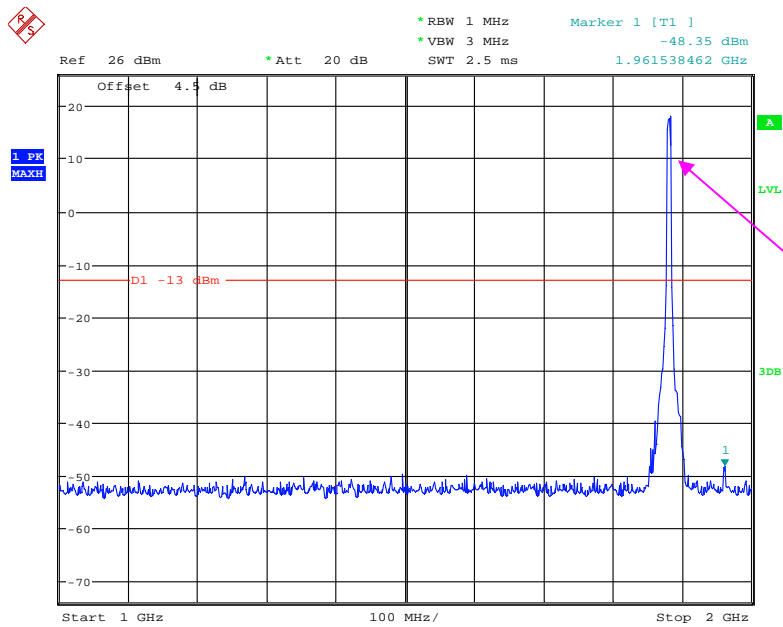

Date: 18.APR.2018 11:15:16

2 GHz – 20 GHz (5.0 MHz, Middle Channel)

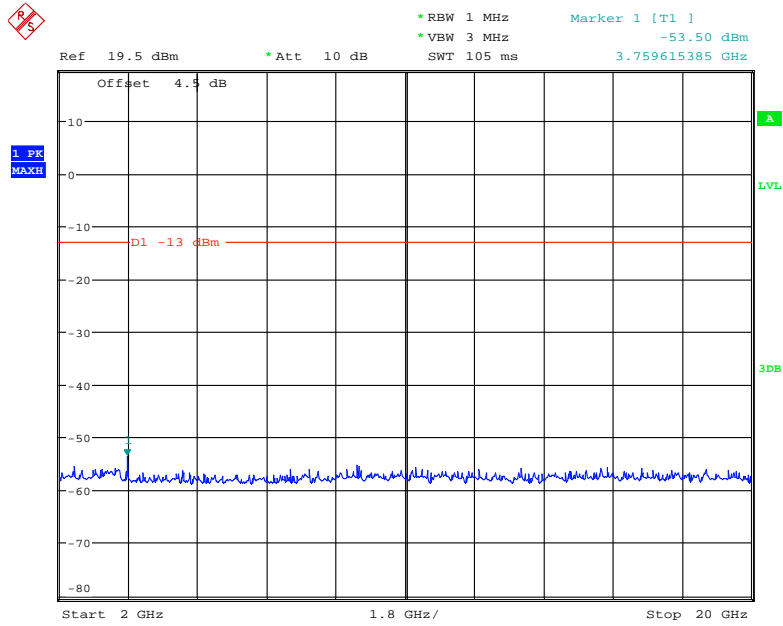

Date: 18.APR.2018 11:25:53

30 MHz - 1 GHz (10.0 MHz, Middle Channel)

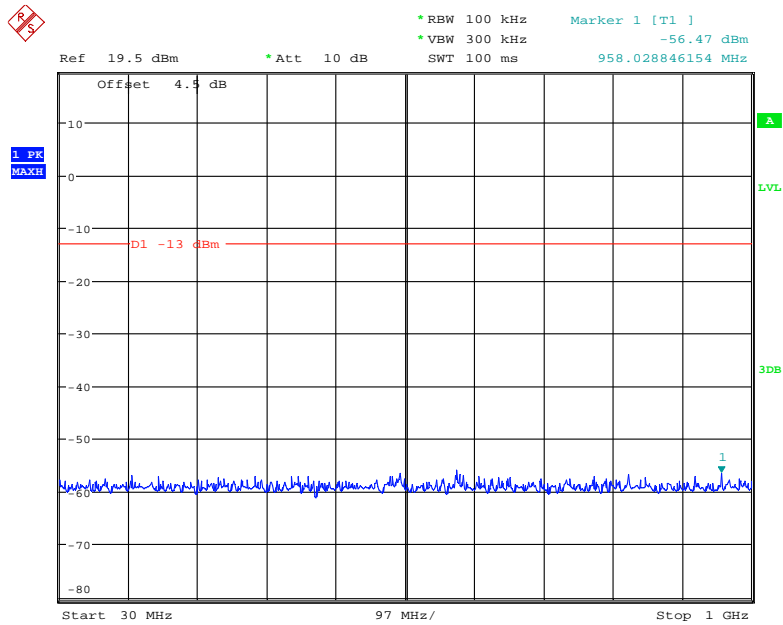

Date: 18.APR.2018 11:30:17

1 GHz – 2 GHz (10.0 MHz, Middle Channel)

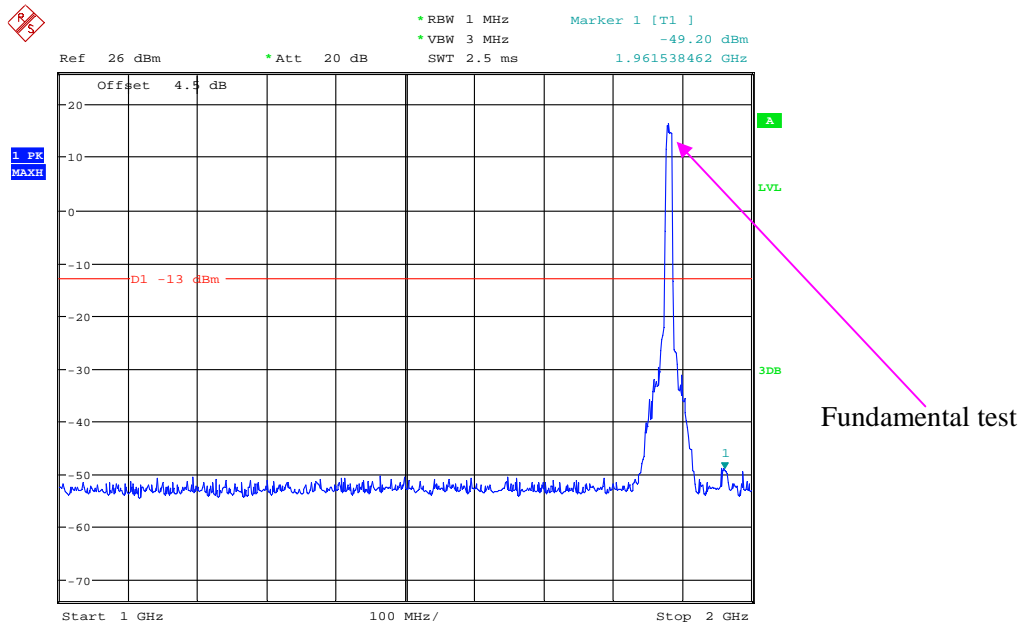

Date: 18.APR.2018 11:15:41

2 GHz – 20 GHz (10.0 MHz, Middle Channel)

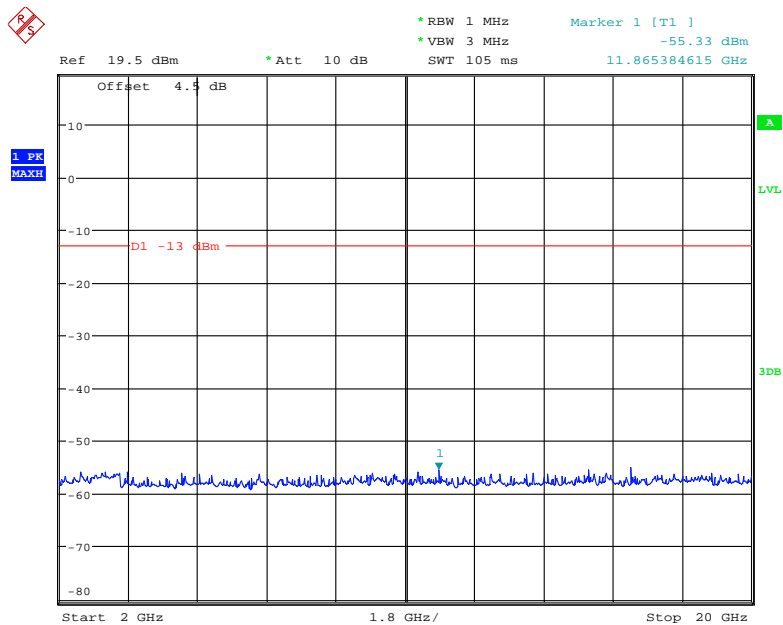

Date: 18.APR.2018 11:26:18

30 MHz - 1 GHz (15.0 MHz, Middle Channel)

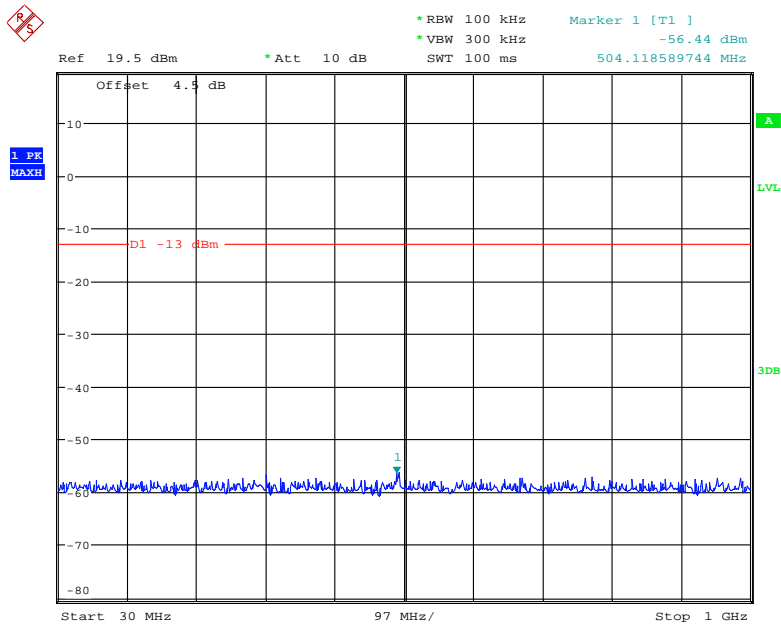

Date: 18.APR.2018 11:30:37

1 GHz - 2 GHz (15.0 MHz, Middle Channel)

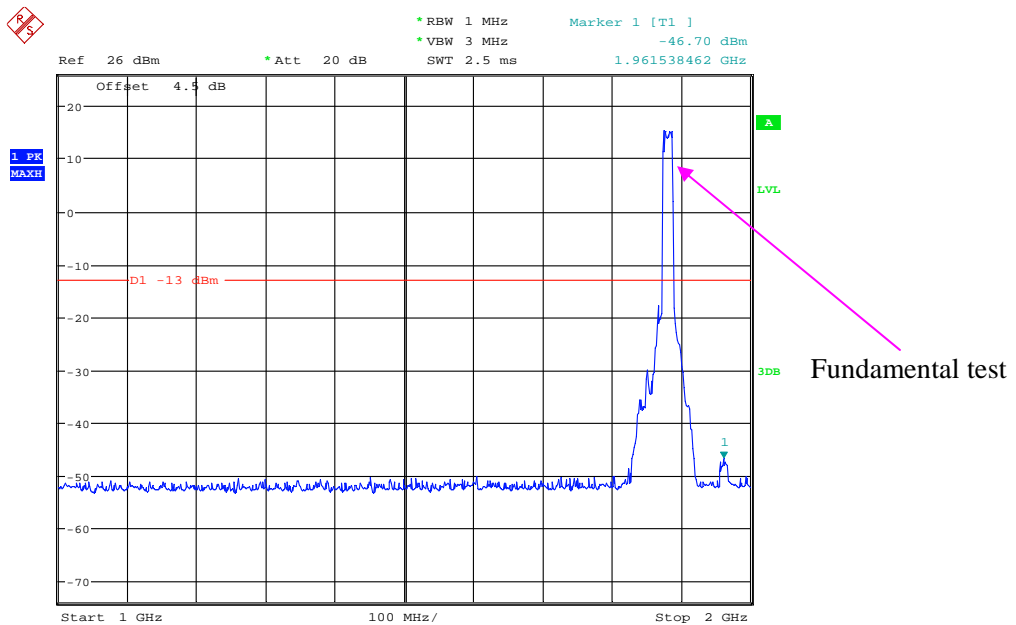

Date: 18.APR.2018 11:16:23

2 GHz – 20 GHz (15.0 MHz, Middle Channel)

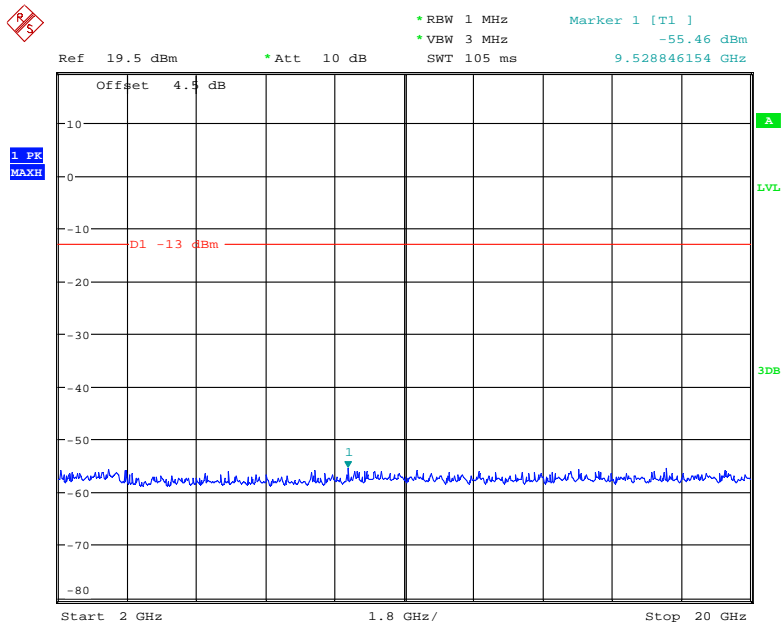

Date: 18.APR.2018 11:26:52

30 MHz - 1 GHz (20.0 MHz, Middle Channel)

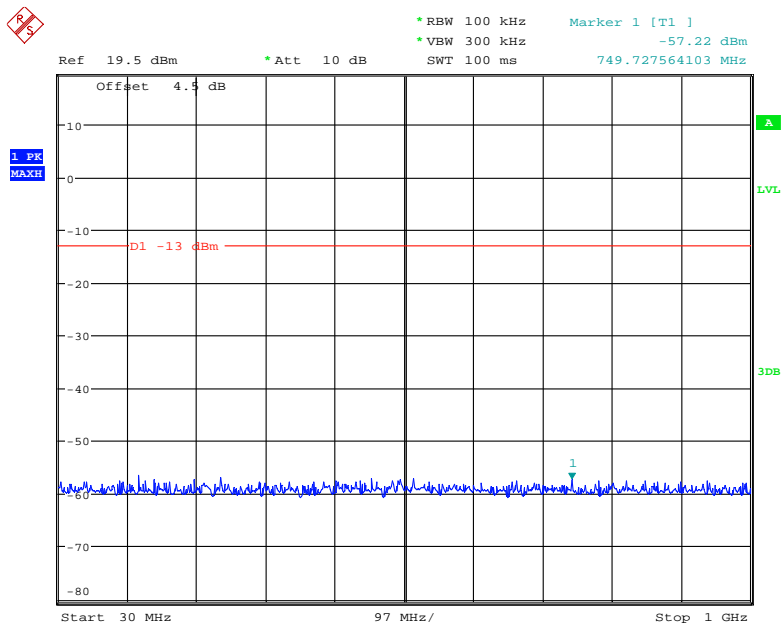

Date: 18.APR.2018 11:30:54

1 GHz – 2 GHz (20.0 MHz, Middle Channel)

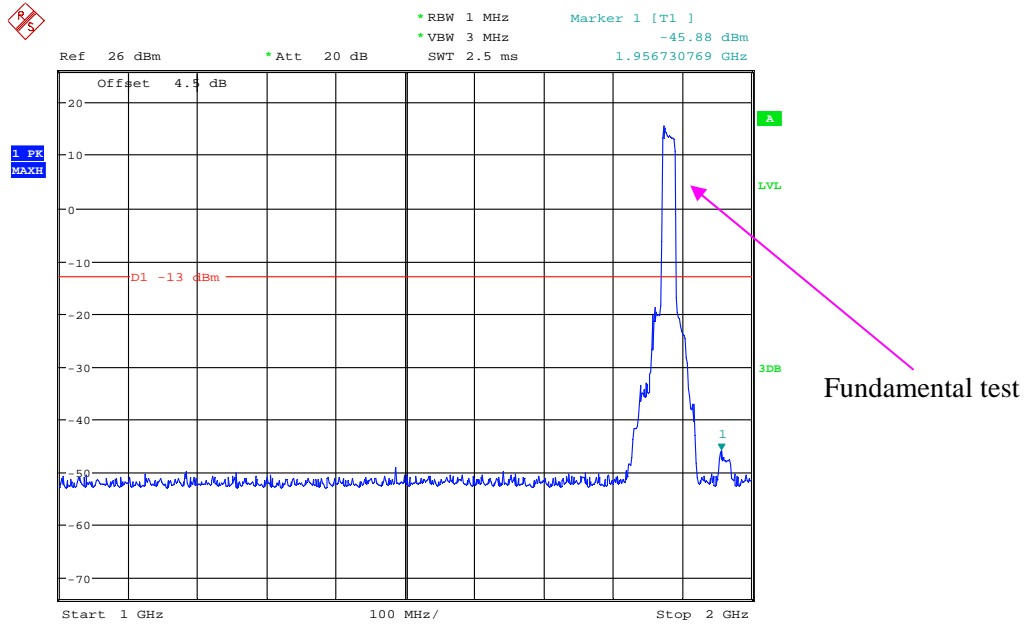

Date: 18.APR.2018 11:16:52

2 GHz – 20 GHz (20.0 MHz, Middle Channel)

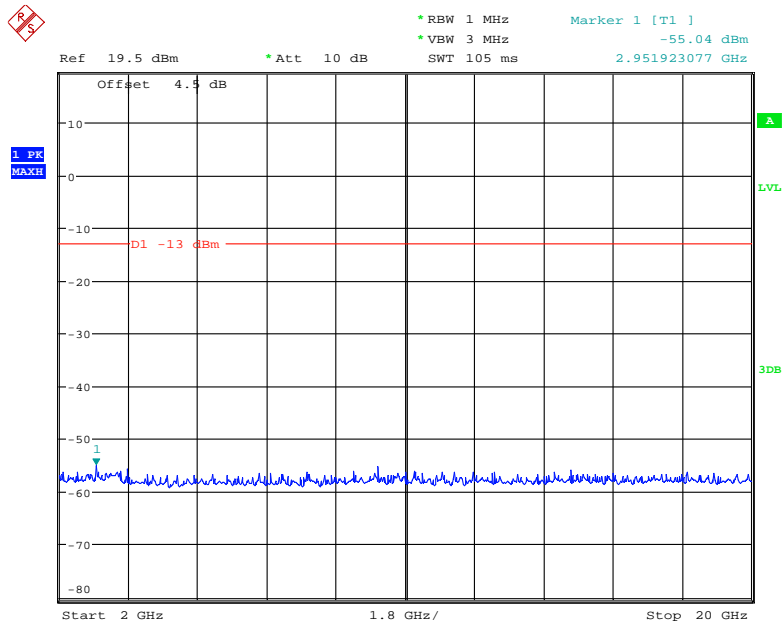

Date: 18.APR.2018 11:27:11

LTE Band 4:

30 MHz - 1 GHz (1.4 MHz, Middle Channel)

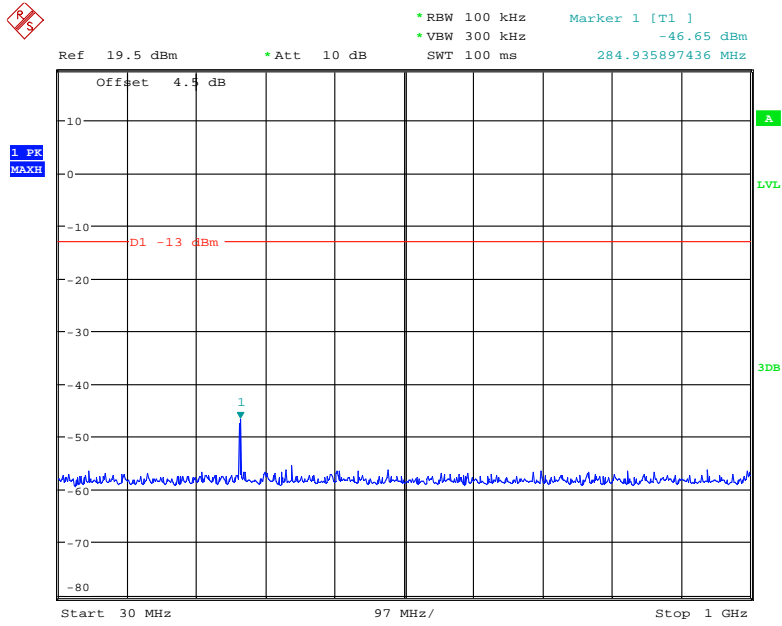

Date: 18.APR.2018 11:39:54

1 GHz - 2 GHz (1.4 MHz, Middle Channel)

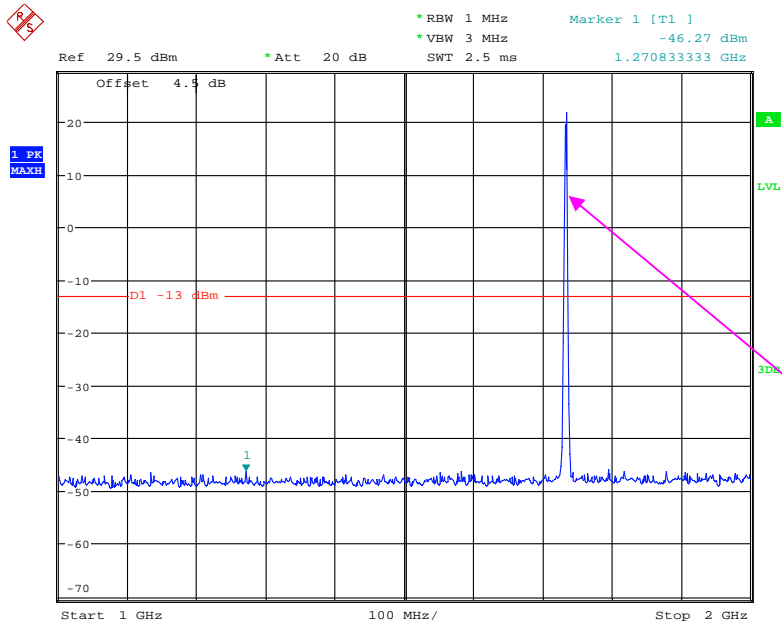

Fundamental test

Date: 18.APR.2018 11:32:49

2 GHz – 20 GHz (1.4 MHz, Middle Channel)

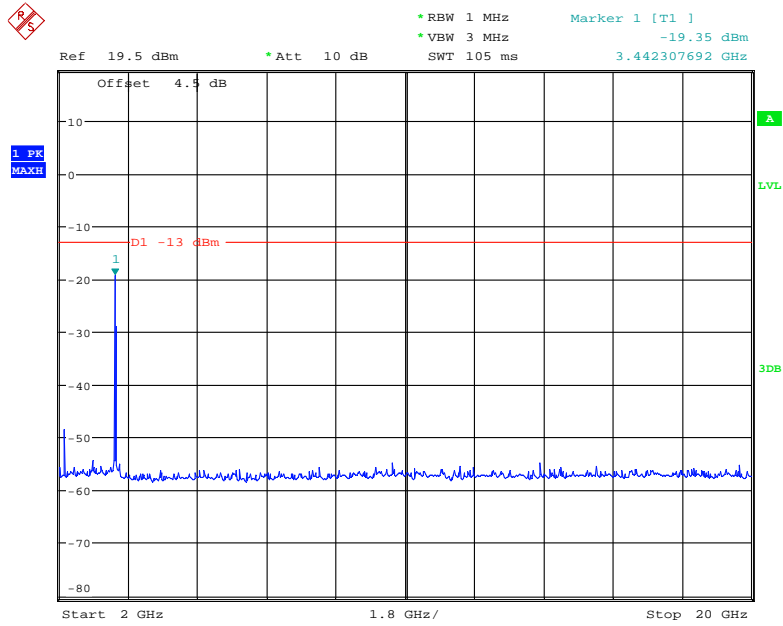

Date: 18.APR.2018 11:37:16

30 MHz - 1 GHz (3.0 MHz, Middle Channel)

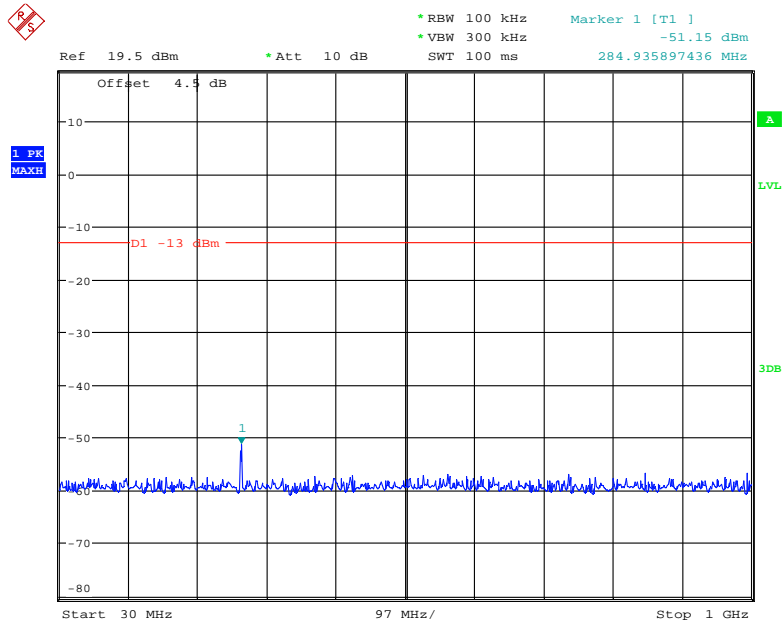

Date: 18.APR.2018 11:40:19

1 GHz – 2 GHz (3.0 MHz, Middle Channel)

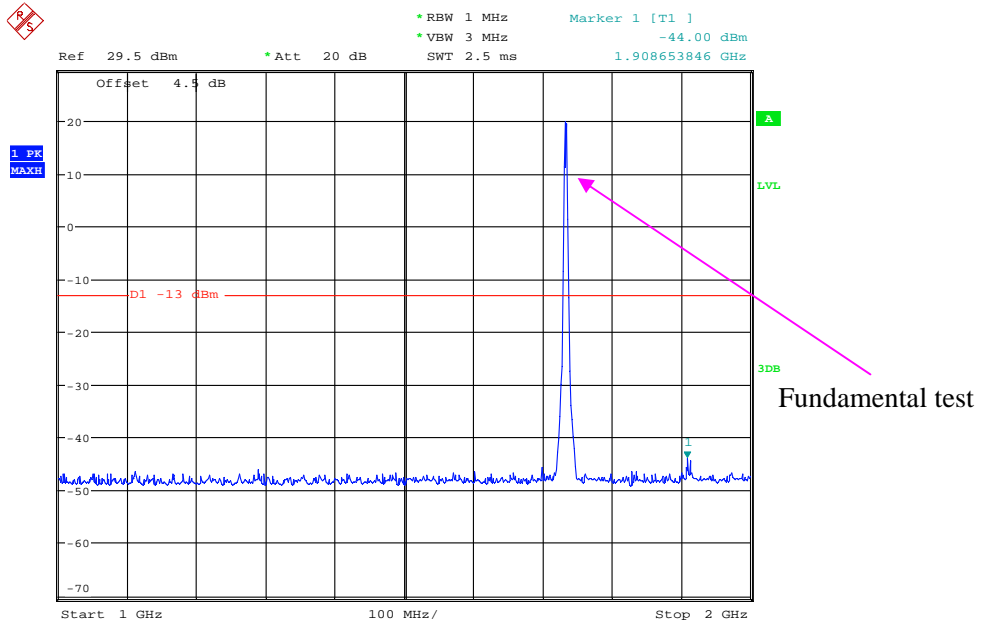

Date: 18.APR.2018 11:33:38

2 GHz – 20 GHz (3.0 MHz, Middle Channel)

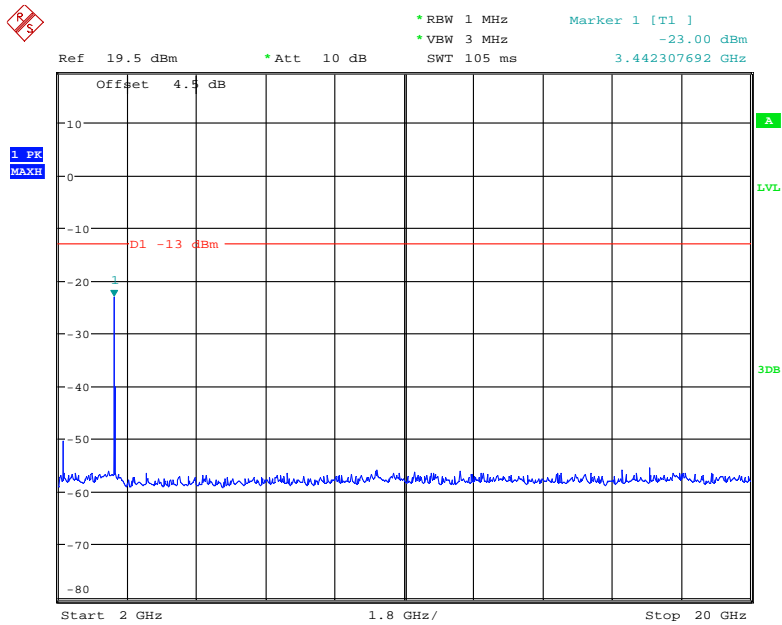

Date: 18.APR.2018 11:37:41

30 MHz - 1 GHz (5.0 MHz, Middle Channel)

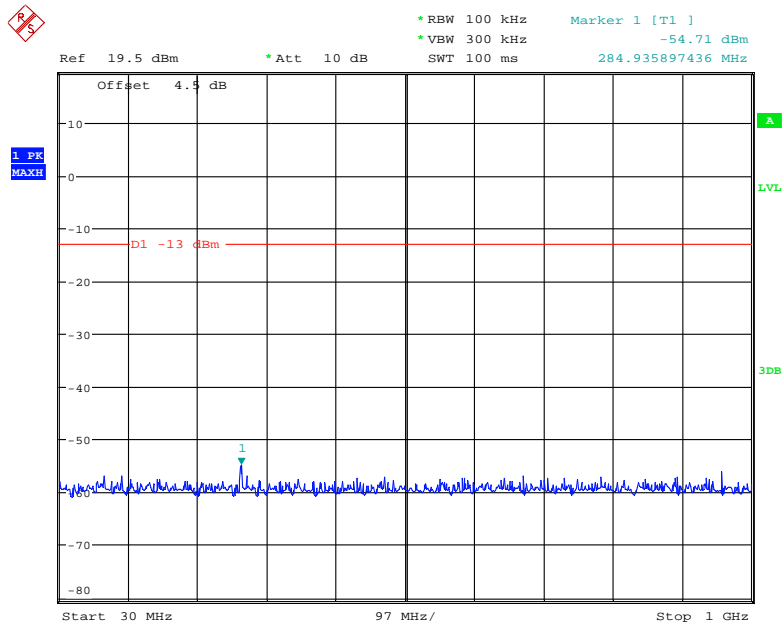

Date: 18.APR.2018 11:40:35

1 GHz - 2 GHz (5.0 MHz, Middle Channel)

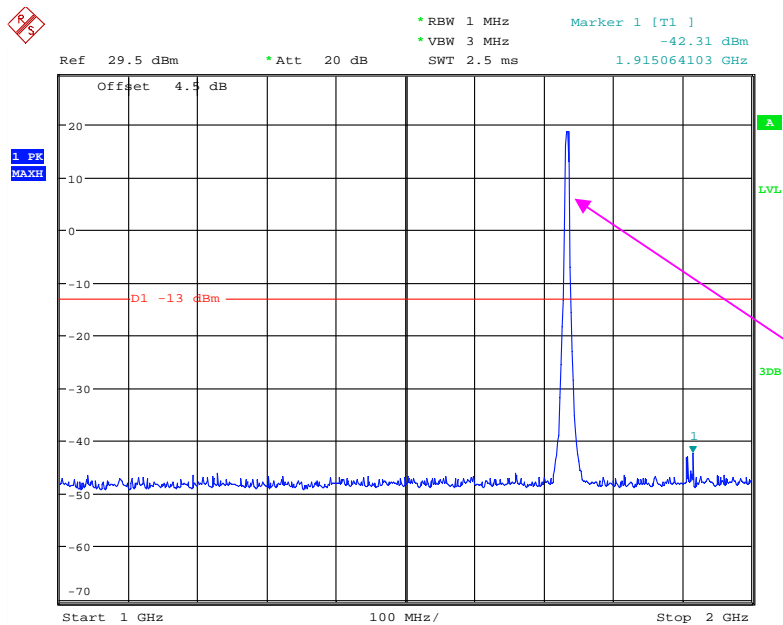

Date: 18.APR.2018 11:34:17

2 GHz – 20 GHz (5.0 MHz, Middle Channel)

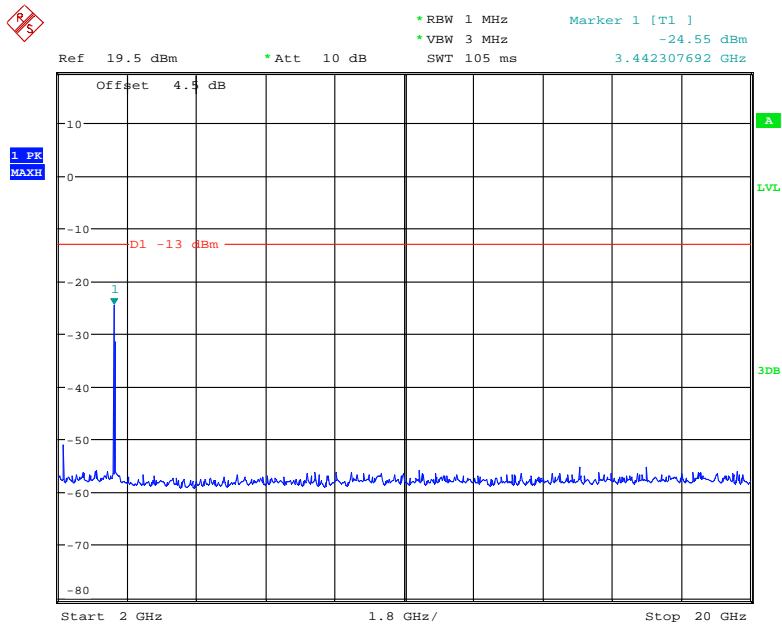

Date: 18.APR.2018 11:37:58

30 MHz - 1 GHz (10.0 MHz, Middle Channel)

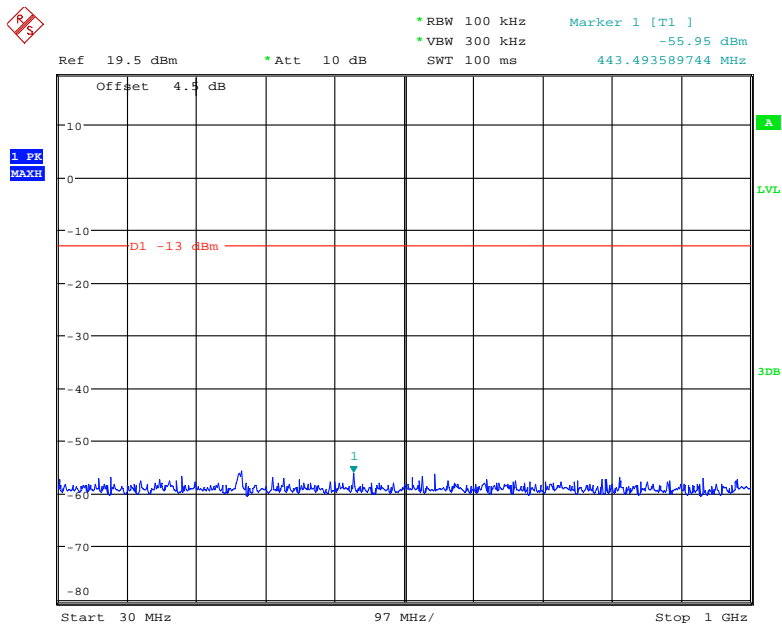

Date: 18.APR.2018 11:40:53

1 GHz – 2 GHz (10.0 MHz, Middle Channel)

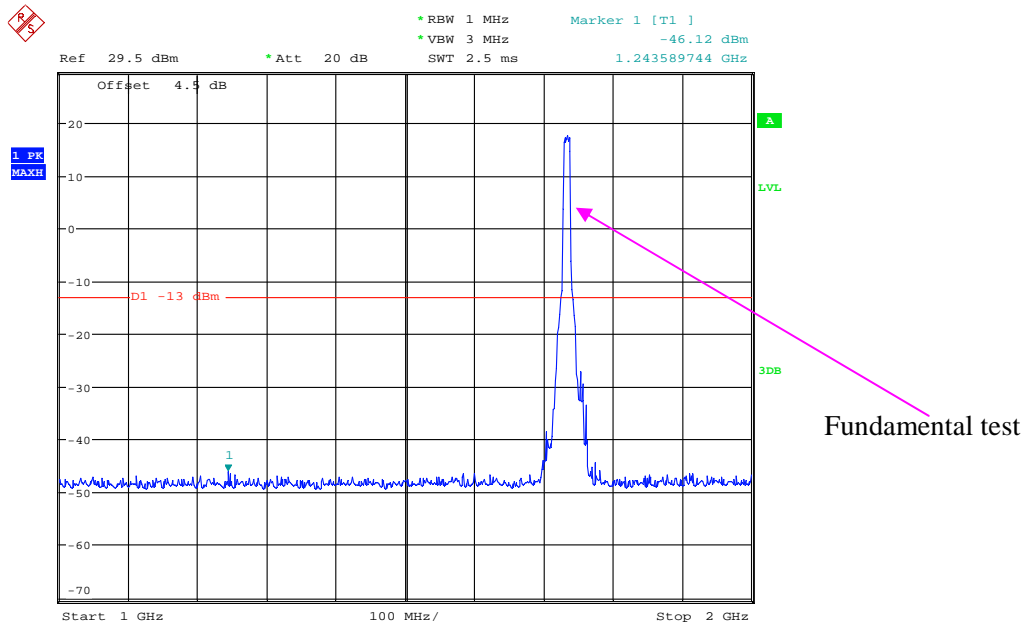

Date: 18.APR.2018 11:34:45

2 GHz – 20 GHz (10.0 MHz, Middle Channel)

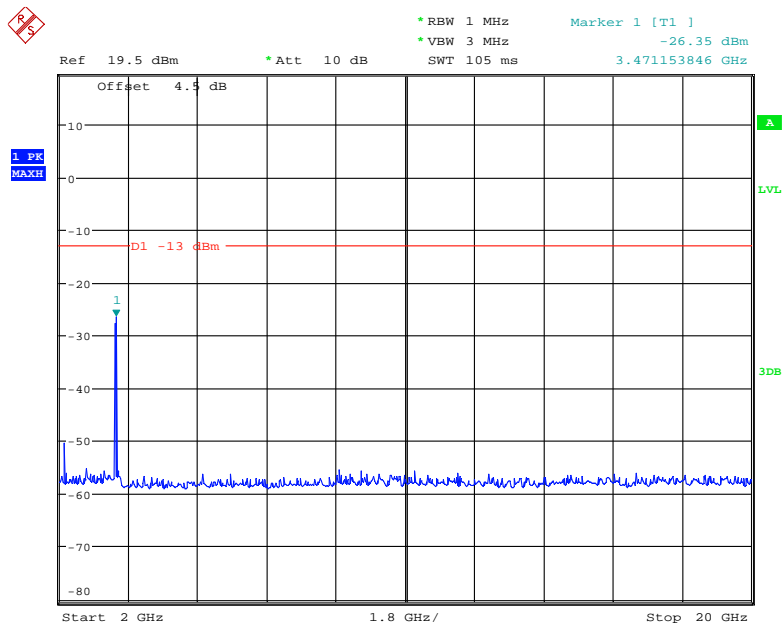

Date: 18.APR.2018 11:38:16

30 MHz - 1 GHz (15.0 MHz, Middle Channel)

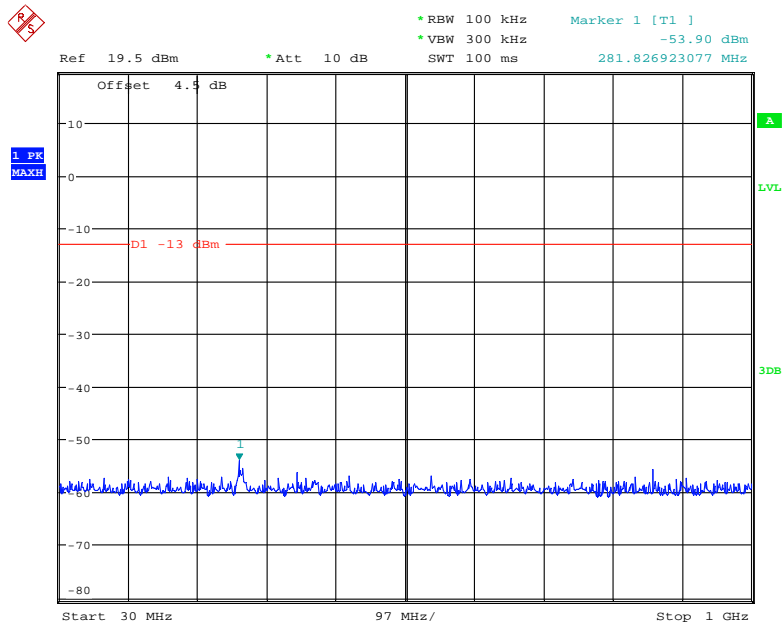

Date: 18.APR.2018 11:41:11

1 GHz - 2 GHz (15.0 MHz, Middle Channel)

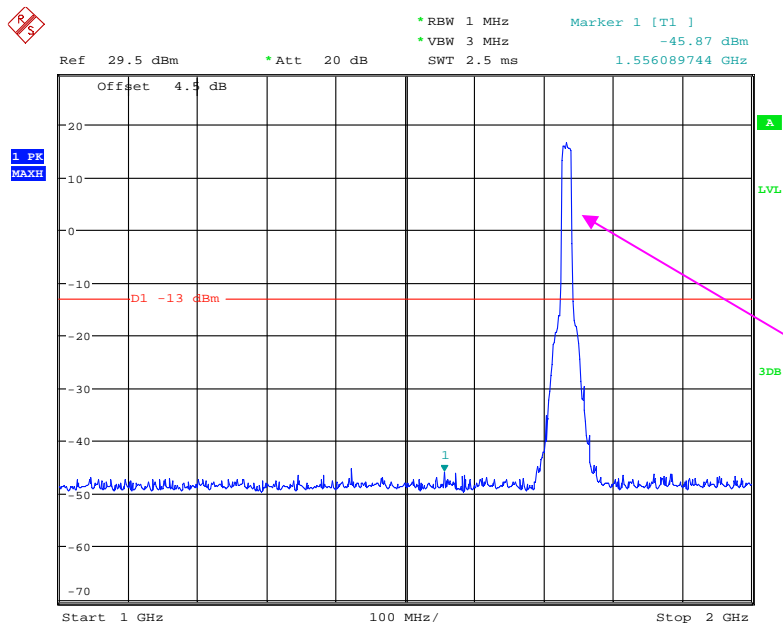

Date: 18.APR.2018 11:35:08

2 GHz – 20 GHz (15.0 MHz, Middle Channel)

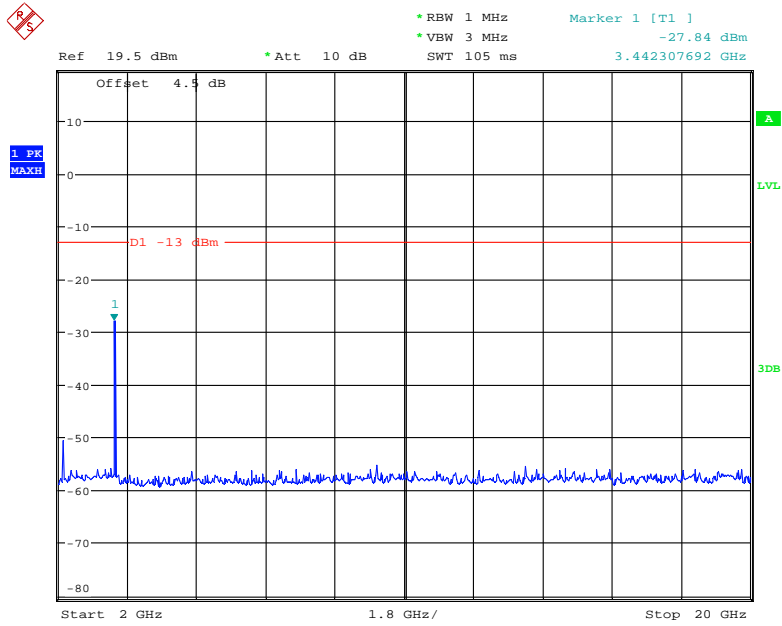

Date: 18.APR.2018 11:38:39

30 MHz - 1 GHz (20.0 MHz, Middle Channel)

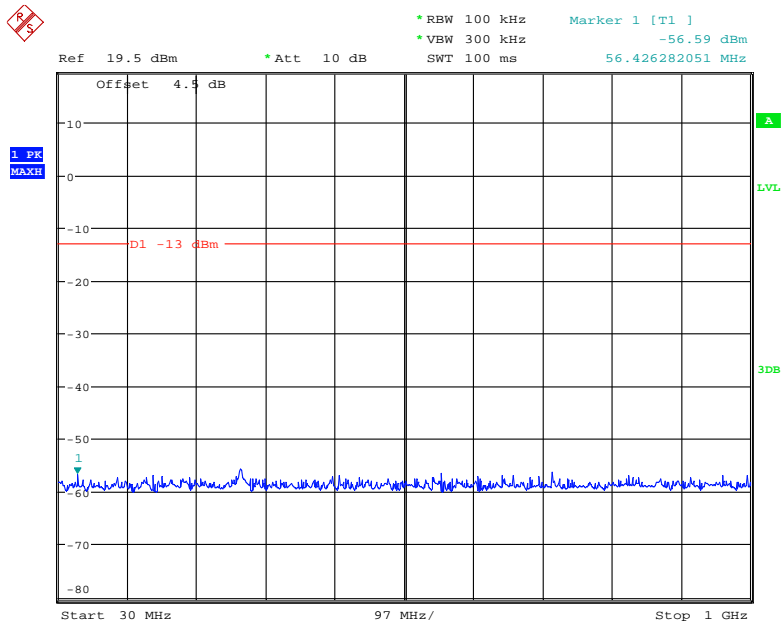

Date: 18.APR.2018 11:41:33

1 GHz – 2 GHz (20.0 MHz, Middle Channel)

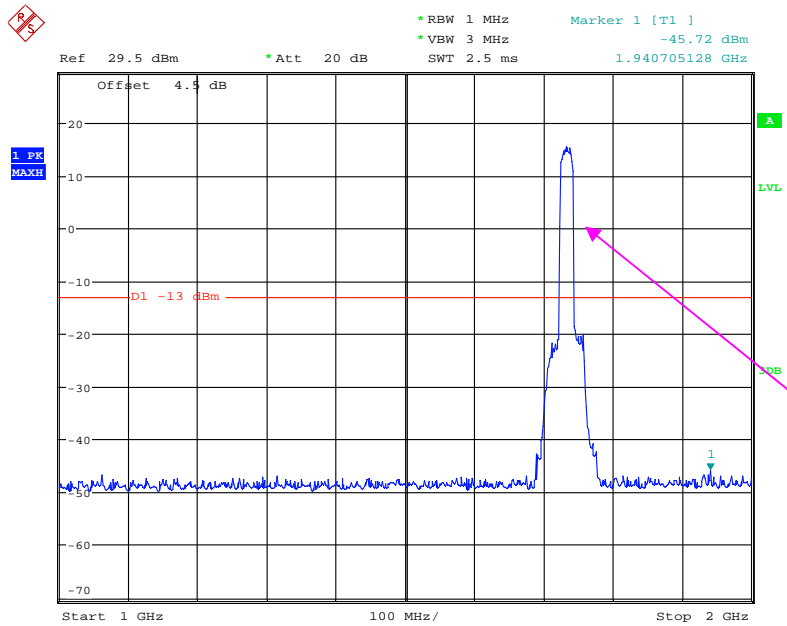

Fundamental test

Date: 18.APR.2018 11:35:31

2 GHz – 20 GHz (20.0 MHz, Middle Channel)

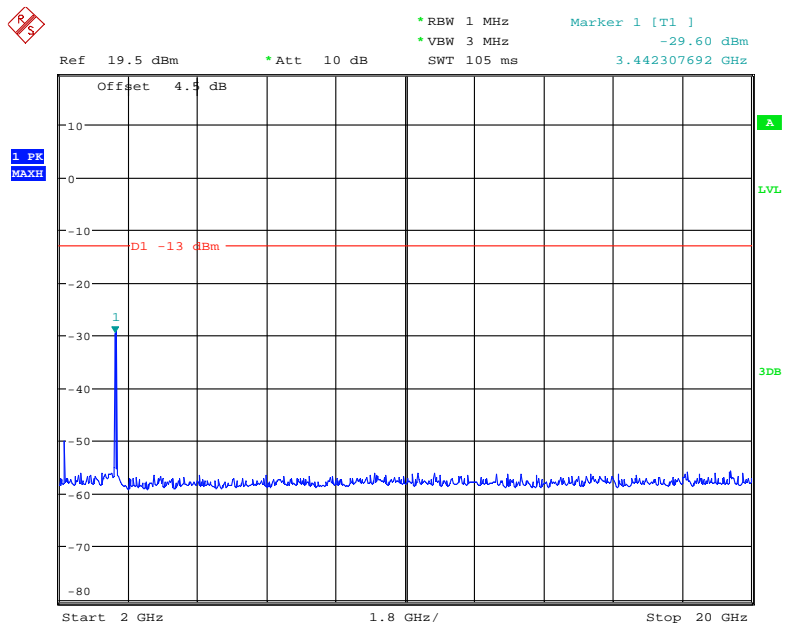

Date: 18.APR.2018 11:38:58

LTE Band 5:

30 MHz - 1 GHz (1.4 MHz, Middle Channel)

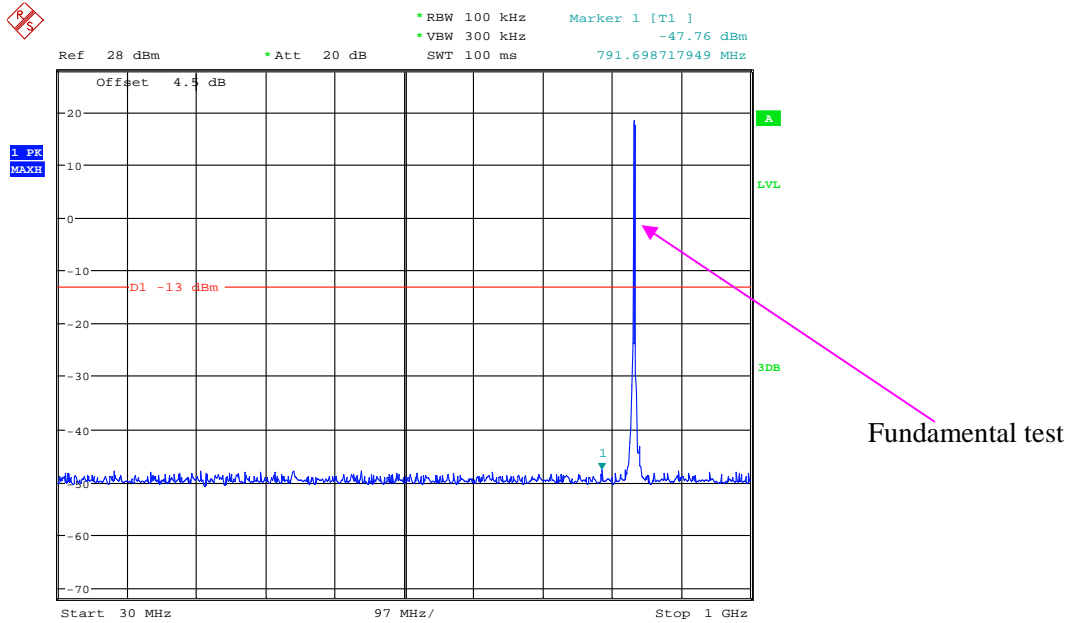

Date: 18.APR.2018 11:48:34

1 GHz - 9 GHz (1.4 MHz, Middle Channel)

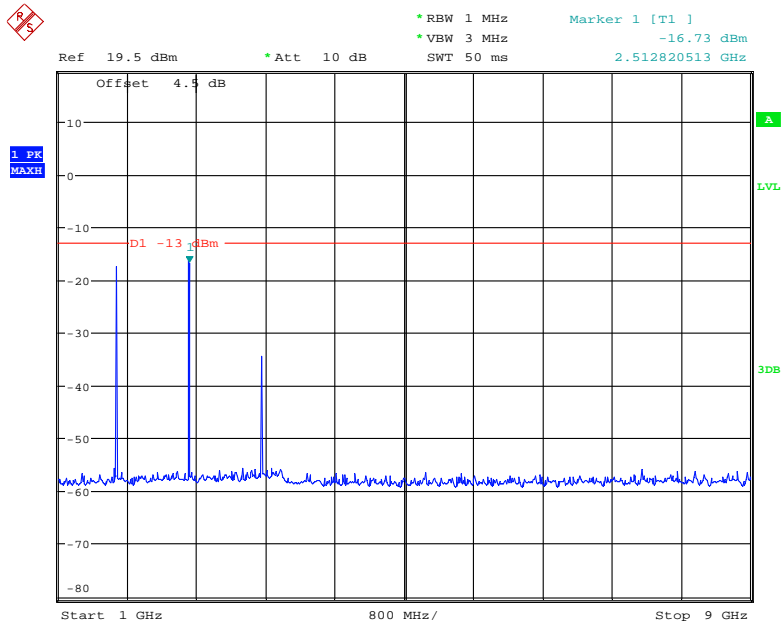

Date: 18.APR.2018 11:43:56

30 MHz - 1 GHz (3.0 MHz, Middle Channel)

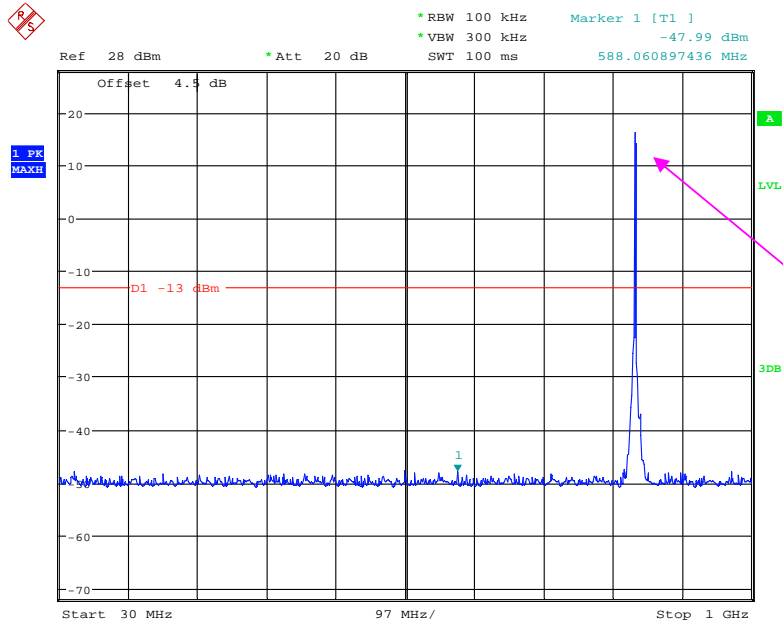

Date: 18.APR.2018 11:49:23

1 GHz - 9 GHz (3.0 MHz, Middle Channel)

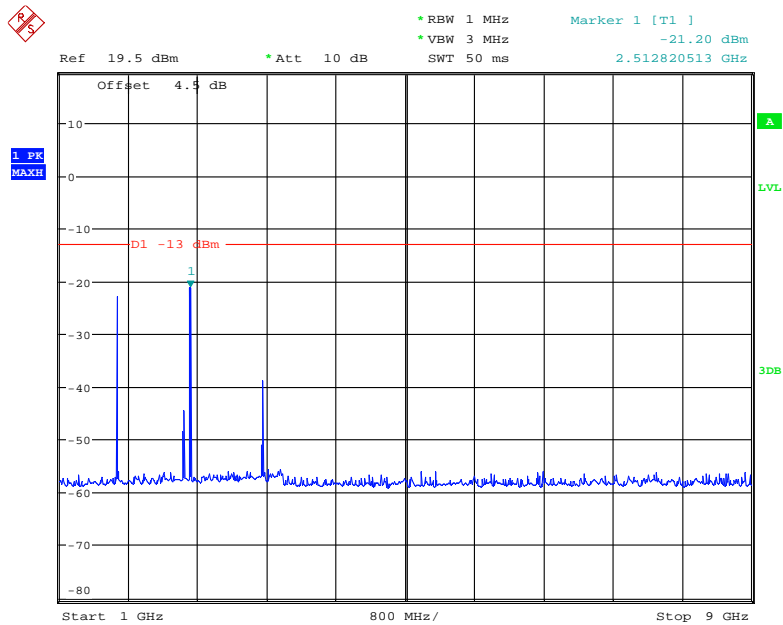

Date: 18.APR.2018 11:44:18

30 MHz - 1 GHz (5.0 MHz, Middle Channel)

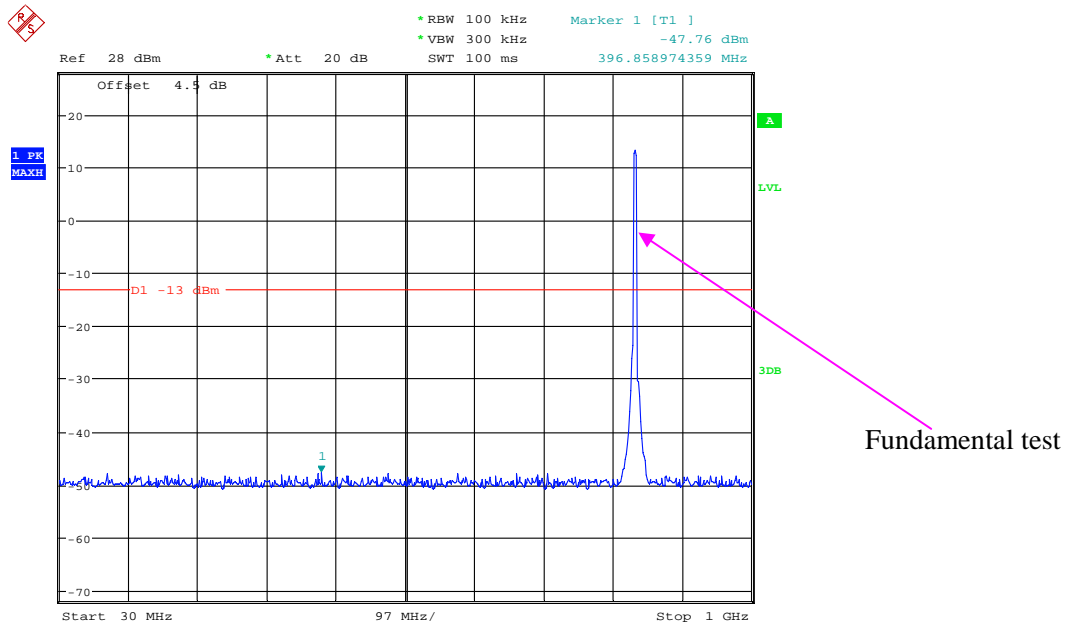

Date: 18.APR.2018 11:49:54

1 GHz - 9 GHz (5.0 MHz, Middle Channel)

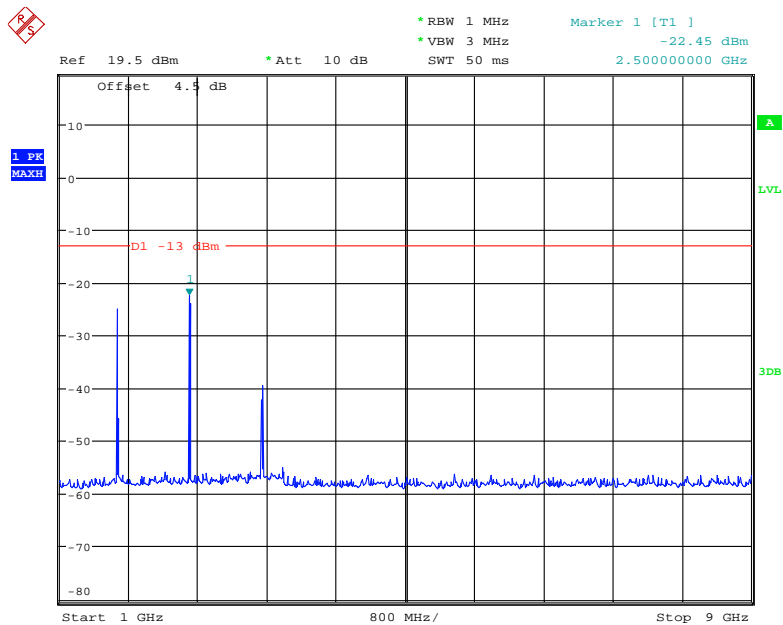

Date: 18.APR.2018 11:44:38

30 MHz - 1 GHz (10.0 MHz, Middle Channel)

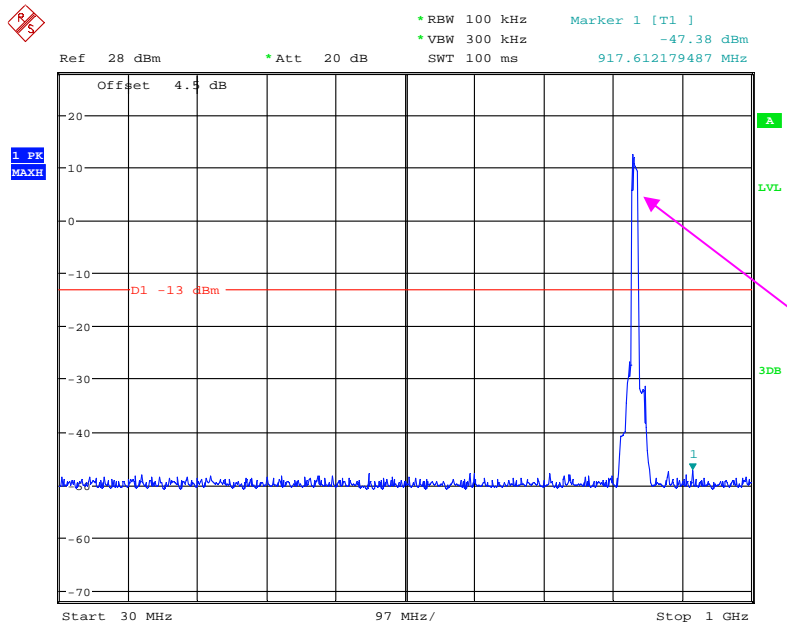

Fundamental test

Date: 18.APR.2018 11:50:26

1 GHz - 9 GHz (10.0 MHz, Middle Channel)

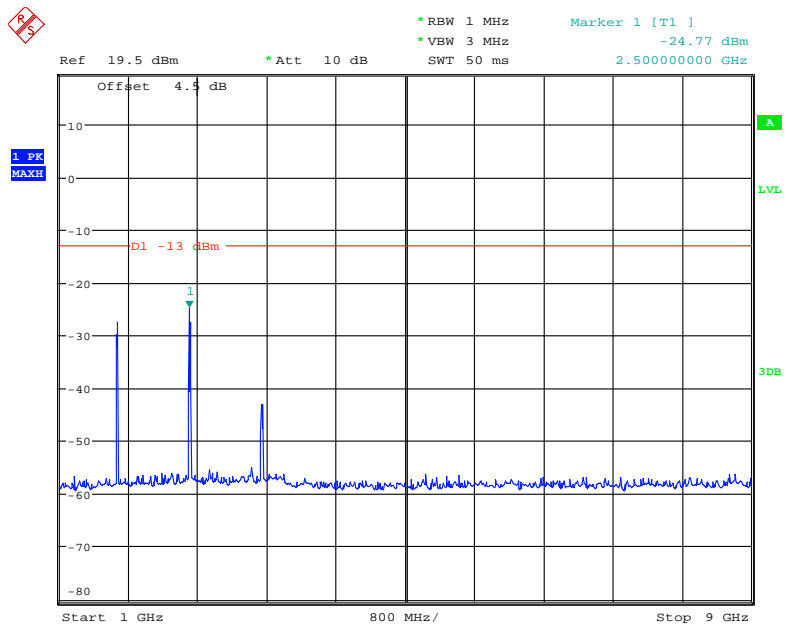

Date: 18.APR.2018 11:44:55

LTE Band 7:

30 MHz – 1 GHz (5.0 MHz, Middle Channel)

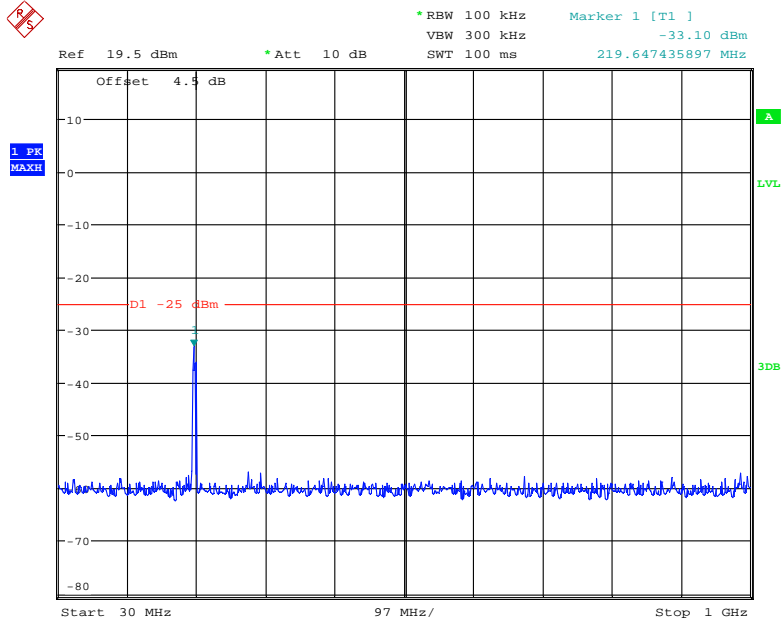

Date: 24.APR.2018 15:22:22

1 GHz – 3GHz (5.0 MHz, Middle Channel)

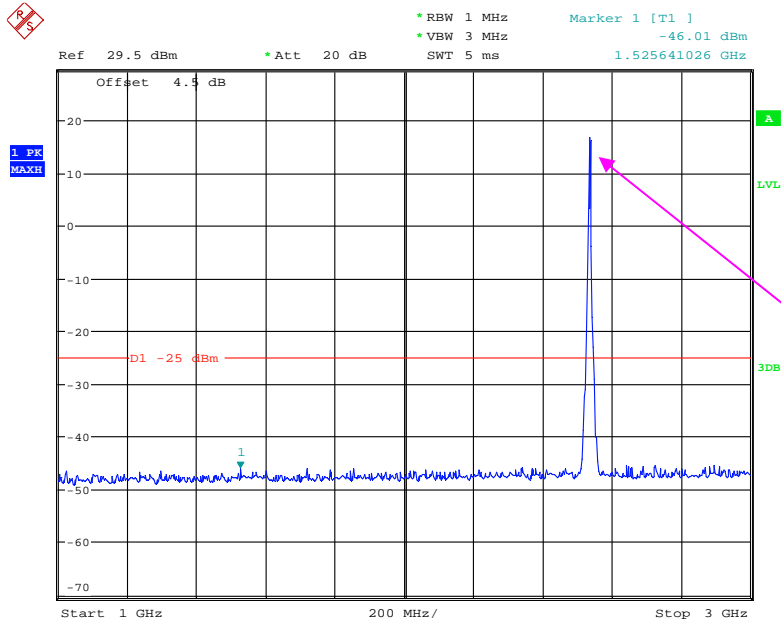

Fundamental test

Date: 24.APR.2018 15:15:08

3 GHz – 26 GHz (5.0 MHz, Middle Channel)

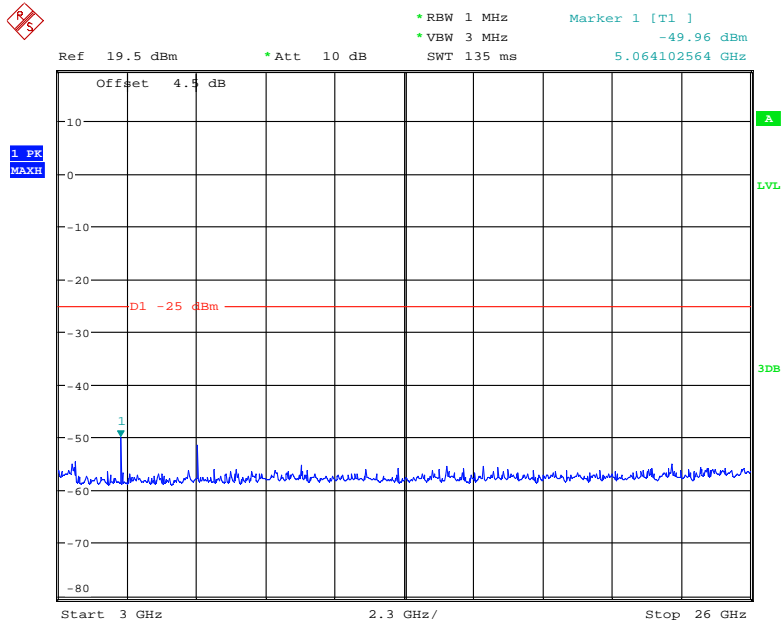

Date: 24.APR.2018 15:17:16

30 MHz – 1 GHz (10.0 MHz, Middle Channel)

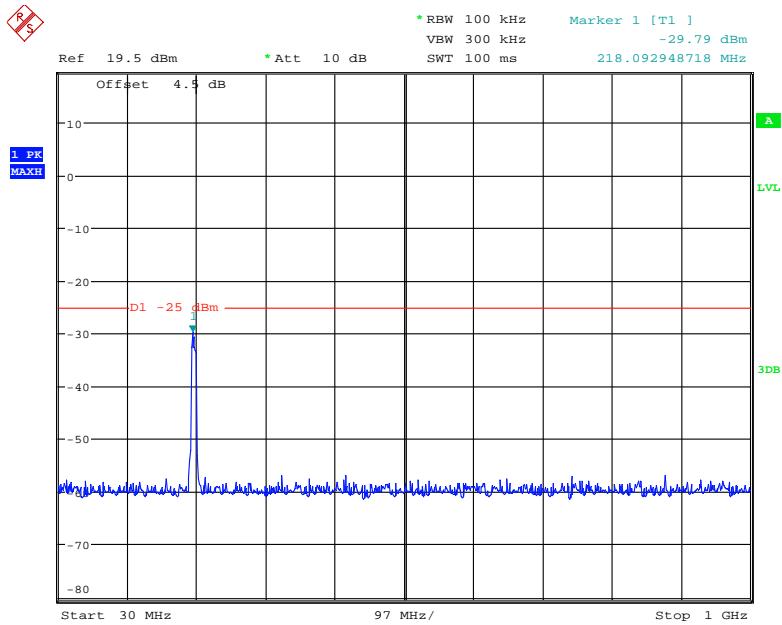

Date: 24.APR.2018 15:19:15

1 GHz – 3GHz (10.0 MHz, Middle Channel)

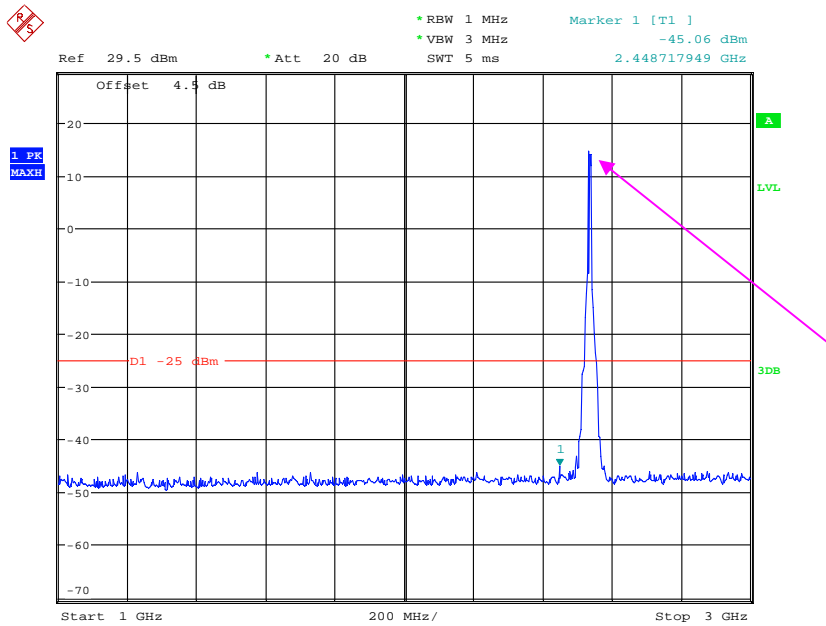

Date: 24.APR.2018 15:15:45

3 GHz – 26 GHz (10.0 MHz, Middle Channel)

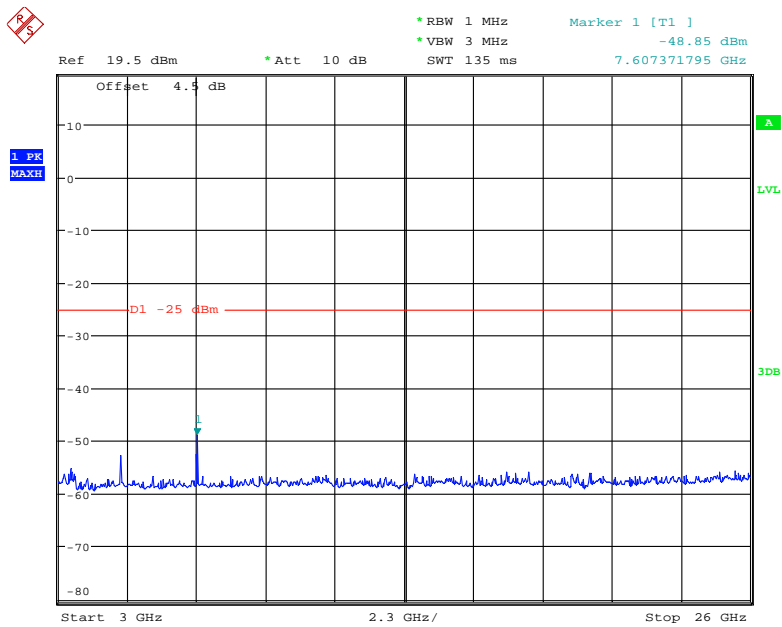

Date: 24.APR.2018 15:17:34

30 MHz – 1 GHz (15.0 MHz, Middle Channel)

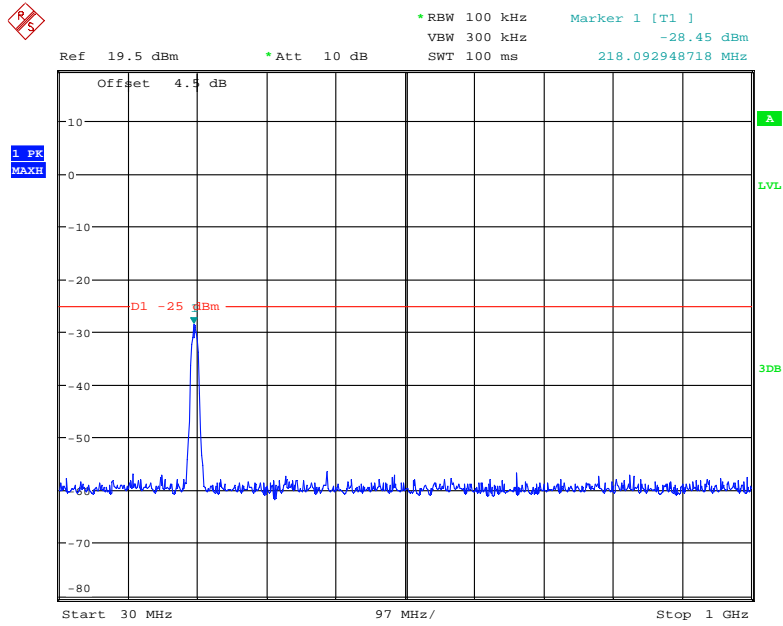

Date: 24.APR.2018 15:19:03

1 GHz – 3GHz (15.0 MHz, Middle Channel)

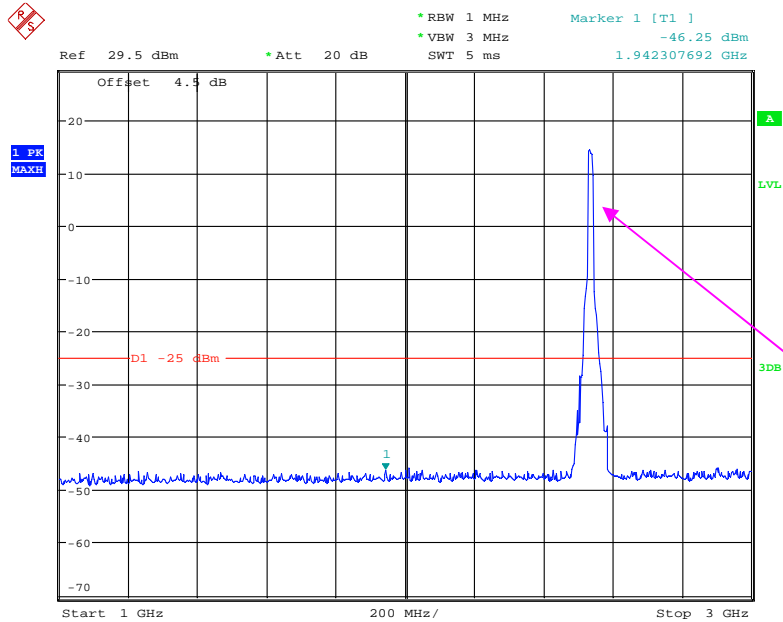

Date: 24.APR.2018 15:16:11

3 GHz – 26 GHz (15.0 MHz, Middle Channel)

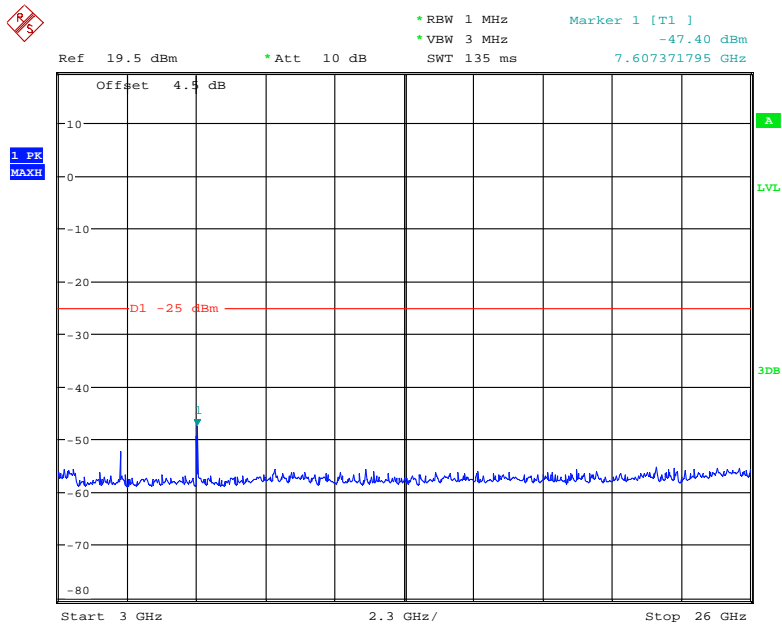

Date: 24.APR.2018 15:17:48

30 MHz – 1 GHz (20.0 MHz, Middle Channel)

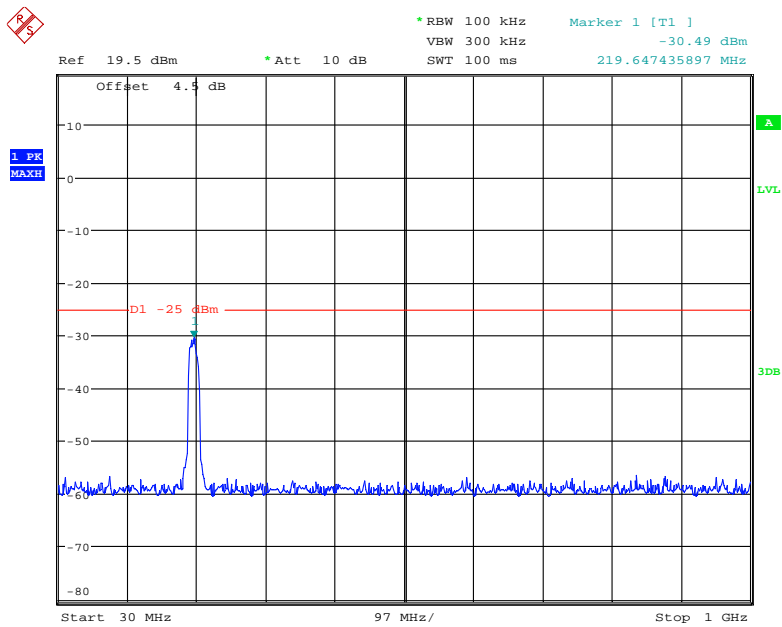

Date: 24.APR.2018 15:18:44

1 GHz – 3GHz (20.0 MHz, Middle Channel)

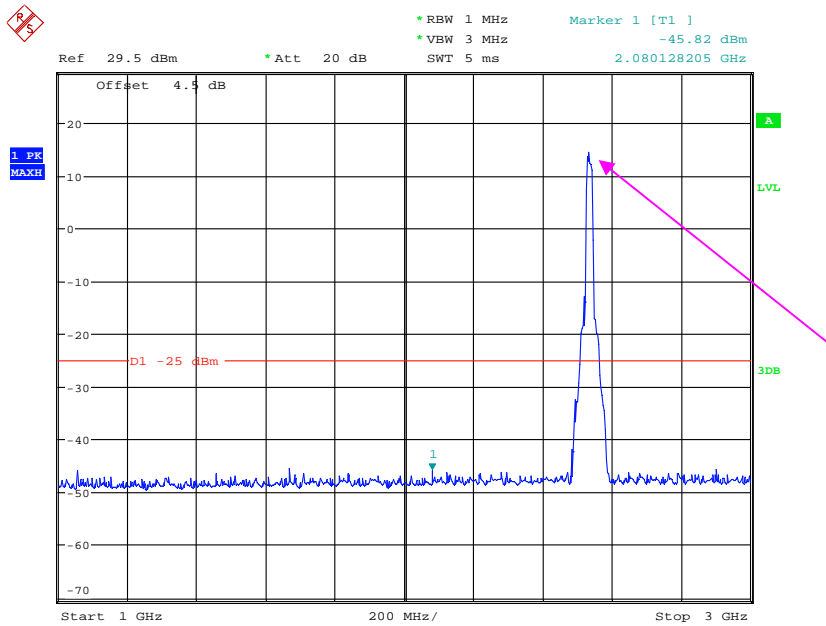

Date: 24.APR.2018 15:16:28

3 GHz – 26 GHz (20.0 MHz, Middle Channel)

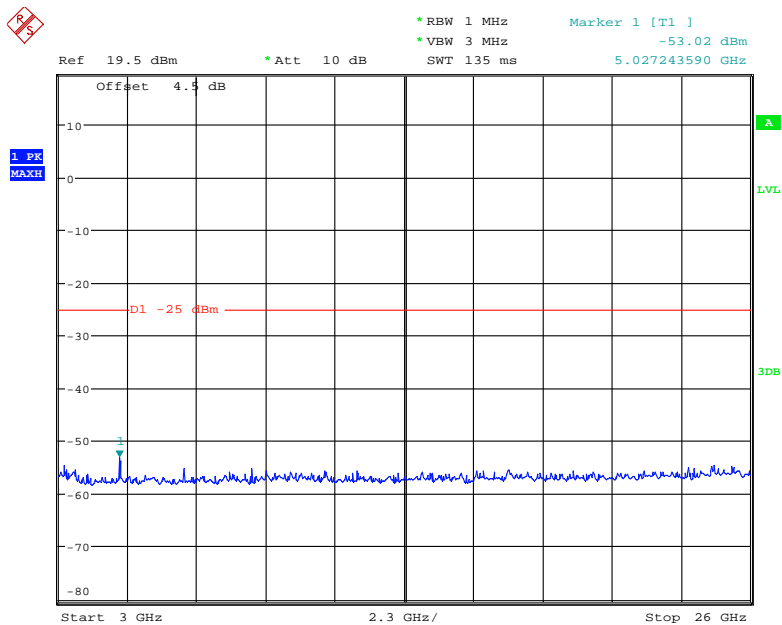

Date: 24.APR.2018 15:18:11

FCC § 2.1053; § 22.917 (a); § 24.238 (a); § 27.53 (h)(m) SPURIOUS RADIATED EMISSIONS

Applicable Standard

FCC § 2.1053, § 22.917(a) and § 24.238(a) and § 27.53(h)(m)

Test Procedure

The transmitter was placed on a wooden turntable, and it was transmitting into a non-radiating load which was also placed on the turntable.

The measurement antenna was placed at a distance of 3 meters from the EUT. During the tests, the receiving antenna height and polarization as well as EUT azimuth were varied in order to identify the maximum level of emissions from the EUT. The test was performed by placing the EUT on 3-orthogonal axis.

The frequency range up to tenth harmonic of the fundamental frequency was investigated.

Test Data**Environmental Conditions**

Temperature:	25 °C
Relative Humidity:	52 %
ATM Pressure:	101.0 kPa

The testing was performed by Tracy Hu on 2018-04-14.

EUT operation mode: Transmitting

Pre-scan with Low, Middle and High channel, the worst case as below:

30 MHz ~ 10 GHz:

Cellular Band (Part 22H)

Frequency (MHz)	Receiver Reading (dBµV)	Turntable Angle Degree	Rx Antenna		Substituted			Absolute Level (dBm)	FCC Part 22H	
			Height (m)	Polar (H/V)	Level (dBm)	Cable Loss (dB)	Antenna Gain (dB)		Limit (dBm)	Margin (dB)
GSM Mode, middle channel										
168.35	33.69	245	2.4	H	-63.30	0.28	0	-63.58	-13	50.58
168.35	32.82	25	1.8	V	-64.20	0.28	0	-64.48	-13	51.48
1673.20	65.05	93	1.3	H	-42.0	1.30	8.90	-34.40	-13	21.40
1673.20	65.17	317	1.7	V	-41.3	1.30	8.90	-33.70	-13	20.70
2509.80	62.69	205	1.6	H	-40.8	2.60	10.20	-33.20	-13	20.20
2509.80	60.01	189	1.4	V	-42.9	2.60	10.20	-35.30	-13	22.30
4183.00	62.59	314	2.4	H	-38.8	1.50	11.80	-28.50	-13	15.50
4183.00	65.47	46	1.9	V	-35.1	1.50	11.80	-24.80	-13	11.80
WCDMA Mode, Middle channel										
168.35	33.63	142	1.7	H	-63.40	0.28	0	-63.68	-13	50.68
168.35	31.57	277	1.7	V	-65.40	0.28	0	-65.68	-13	52.68
1673.2	66.59	290	1.6	H	-40.9	1.30	8.90	-33.30	-13	20.30
1673.2	68.51	173	2.3	V	-38.4	1.30	8.90	-30.80	-13	17.80
2509.8	63.87	80	1.5	H	-40.3	2.60	10.20	-32.70	-13	19.70
2509.8	63.58	88	1.2	V	-40.0	2.60	10.20	-32.40	-13	19.40

30 MHz ~ 20 GHz:

PCS Band (Part 24E)

Frequency (MHz)	Receiver Reading (dBµV)	Turntable Angle Degree	Rx Antenna		Substituted			Absolute Level (dBm)	FCC Part 24E	
			Height (m)	Polar (H/V)	Level (dBm)	Cable Loss (dB)	Antenna Gain (dB)		Limit (dBm)	Margin (dB)
GSM Mode, middle channel										
168.35	33.94	222	2.1	H	-63.10	0.28	0	-63.38	-13	50.38
168.35	31.88	81	1.9	V	-65.10	0.28	0	-65.38	-13	52.38
3760.00	57.09	169	1.5	H	-44.1	1.50	11.80	-33.80	-13	20.80
3760.00	56.3	168	1.8	V	-44.5	1.50	11.80	-34.20	-13	21.20
5640.00	52.16	200	2.3	H	-45.4	1.70	12.40	-34.70	-13	21.70
5640.00	53.87	95	1.0	V	-43.4	1.70	12.40	-32.70	-13	19.70
WCDMA Mode Band II, Middle channel										
168.35	32.74	307	1.8	H	-64.30	0.28	0	-64.58	-13	51.58
168.35	32.46	230	1.8	V	-64.50	0.28	0	-64.78	-13	51.78
3760.00	58.83	85	1.8	H	-42.4	1.50	11.80	-32.10	-13	19.10
3760.00	58.76	117	1.5	V	-42.0	1.50	11.80	-31.70	-13	18.70
5640.00	58.85	242	1.9	H	-38.7	1.70	12.40	-28.00	-13	15.00
5640.00	56.58	41	2.3	V	-40.7	1.70	12.40	-30.00	-13	17.00

LTE Band:

Test mode: Transmitting (Pre-scan with all the bandwidth, and worse case as below)

Frequency (MHz)	Receiver Reading (dBμV)	Turntable Angle Degree	Rx Antenna		Substituted			Absolute Level (dBm)	Limit (dBm)	Margin (dB)
			Height (m)	Polar (H/V)	Level (dBm)	Cable Loss (dB)	Antenna Gain (dB)			
Band 2										
Test frequency range:30 MHz ~ 20 GHz										
168.35	33.02	272	1.6	H	-64.00	0.28	0	-64.28	-13	51.28
168.35	32.03	299	1.3	V	-65.00	0.28	0	-65.28	-13	52.28
3760.00	51.34	44	1.8	H	-49.9	1.50	11.80	-39.60	-13	26.60
3760.00	51.29	5	2.0	V	-49.5	1.50	11.80	-39.20	-13	26.20
Band 4										
Test frequency range:30 MHz ~ 20 GHz										
168.35	32.60	8	2.1	H	-64.40	0.28	0	-64.68	-13	51.68
168.35	32.26	218	1.0	V	-64.70	0.28	0	-64.98	-13	51.98
3465.00	47.07	66	1.2	H	-53.3	1.50	12.00	-42.80	-13	29.80
3465.00	47.98	154	1.8	V	-53.2	1.50	12.00	-42.70	-13	29.70
5197.50	47.49	213	2.3	H	-51.1	1.60	12.10	-40.60	-13	27.60
5197.50	48.83	315	1.8	V	-49.3	1.60	12.10	-38.80	-13	25.80
Band 5										
Test frequency range:30 MHz ~ 9 GHz										
168.35	32.53	242	2.2	H	-64.50	0.28	0	-64.78	-13	51.78
168.35	31.56	180	1.6	V	-65.40	0.28	0	-65.68	-13	52.68
1673.00	47.02	72	2.3	H	-60.1	1.30	8.90	-52.50	-13	39.50
1673.00	46.77	290	1.1	V	-59.7	1.30	8.90	-52.10	-13	39.10
2509.50	47.65	69	2.3	H	-55.9	2.60	10.20	-48.30	-13	35.30
2509.50	48.09	150	1.4	V	-54.8	2.60	10.20	-47.20	-13	34.20
Band 7										
Test frequency range: 30 MHz ~ 26 GHz										
218.96	33.14	113	1.7	H	-63.90	0.28	0	-64.18	-25	39.18
218.96	31.46	149	1.5	V	-65.50	0.28	0	-65.78	-25	40.78
5070.00	57.08	58	1.3	H	-40.8	1.60	12.10	-30.30	-25	5.30
5070.00	56.72	164	2.2	V	-41.2	1.60	12.10	-30.70	-25	5.70

Note:

- 1) Absolute Level = Substituted Level - Cable loss + Antenna Gain
- 2) Margin = Limit- Absolute Level

FCC § 22.917 (a);§ 24.238 (a); §27.53 (h)(m) - BAND EDGES

Applicable Standard

According to § 22.917(a), the power of any emissions outside of the authorized operating frequency ranges must be attenuated below the transmitting power (P) by a factor of at least $43 + 10 \log(P)$ dB.

According to §24.238(a), the power of any emissions outside of the authorized operating frequency ranges must be attenuated below the transmitting power (P) by a factor of at least $43 + 10 \log(P)$ dB.

According to FCC §27.53 (h)(m), the power of any emission outside of the authorized operating frequency ranges must be attenuated below the transmitting power (P) by a factor of at least $43 + 10 \log(P)$ dB.

Test Procedure

The RF output of the transmitter was connected to the input of the spectrum analyzer through sufficient attenuation.

The center of the spectrum analyzer was set to block edge frequency

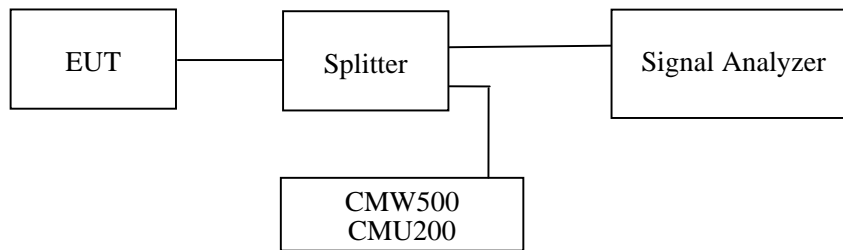

Test Data

Environmental Conditions

Temperature:	21~25 °C
Relative Humidity:	51~52 %
ATM Pressure:	100.5~101.0 kPa

The testing was performed by Tracy Hu on 2018-04-14 and 2018-04-18.

EUT operation mode: Transmitting

Test Result: Compliance. Please refer to the following plots.

Cellular Band, Left Band Edge for GSM (GMSK) Mode

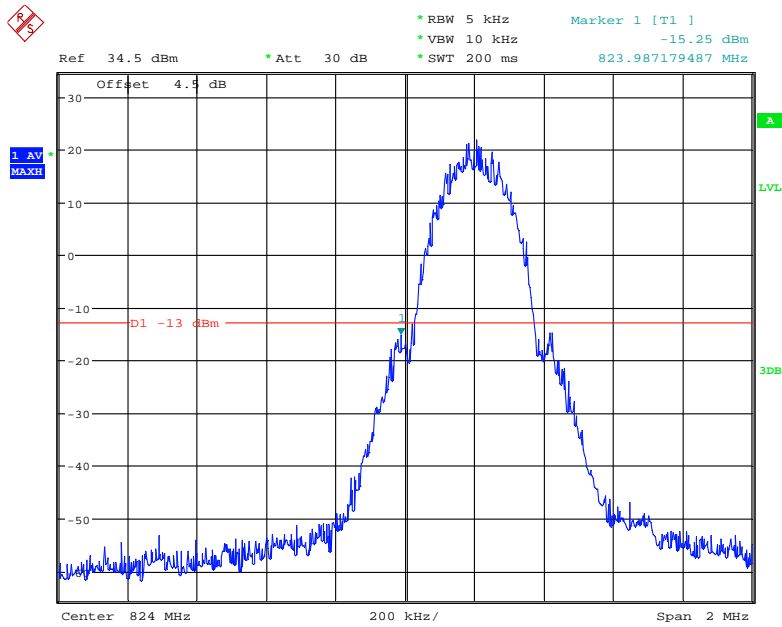

Date: 14.APR.2018 11:09:39

Cellular Band, Right Band Edge for GSM (GMSK) Mode

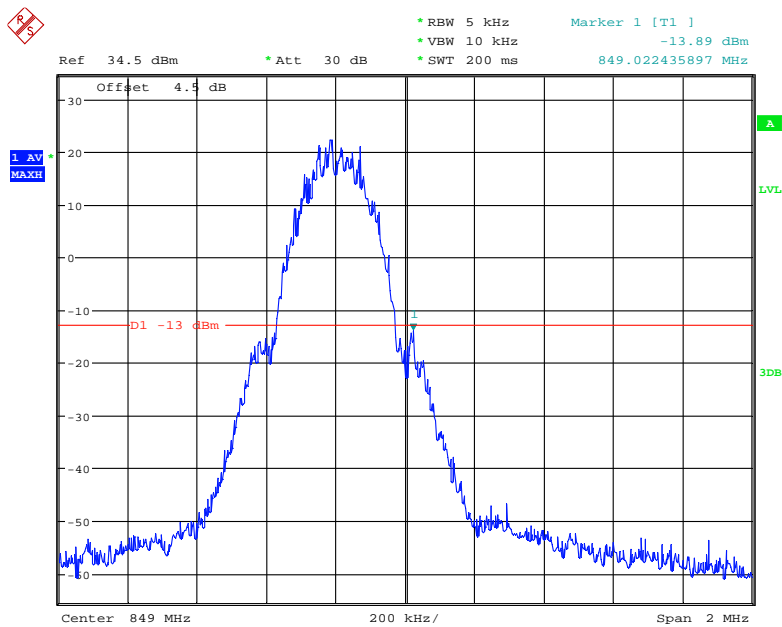

Date: 14.APR.2018 11:10:44

Cellular Band, Left Band Edge for EDGE Mode

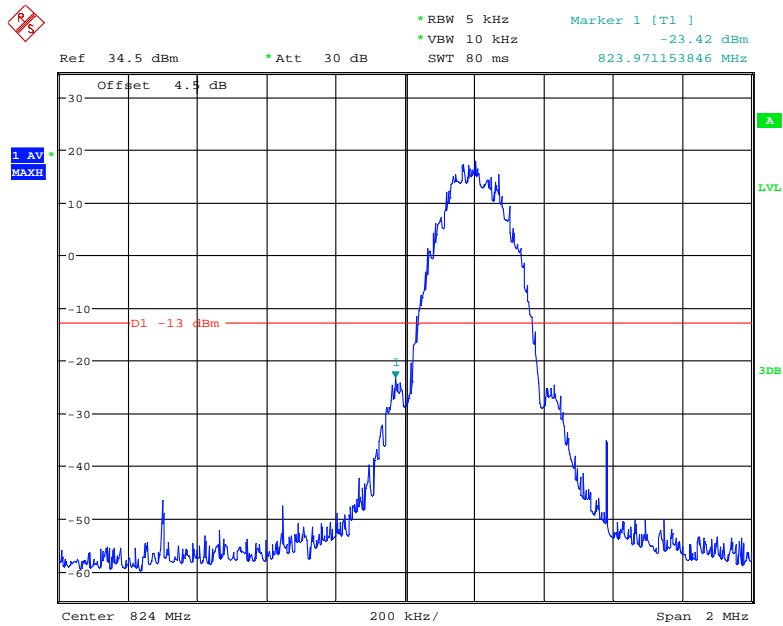

Date: 14.APR.2018 11:27:46

Cellular Band, Right Band Edge for EDGE Mode

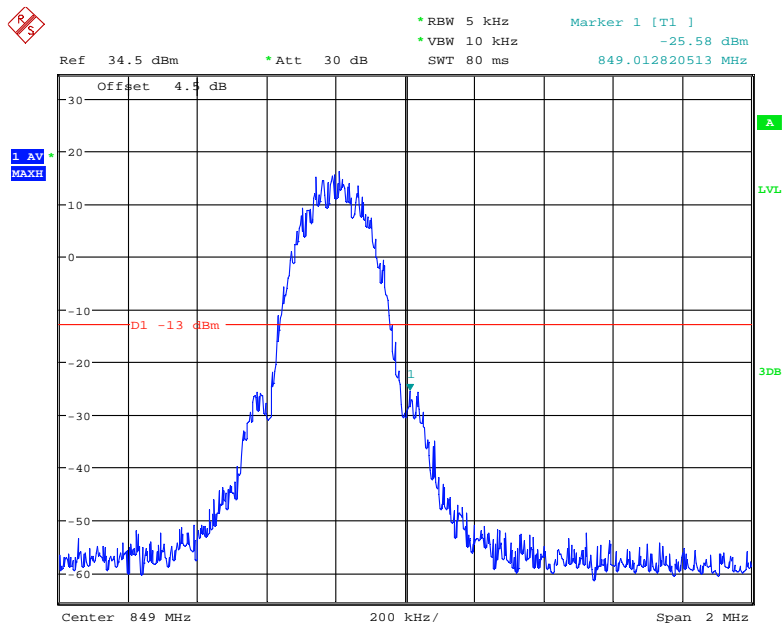

Date: 14.APR.2018 11:28:17

Cellular Band, Left Band Edge for WCDMA (BPSK) Mode

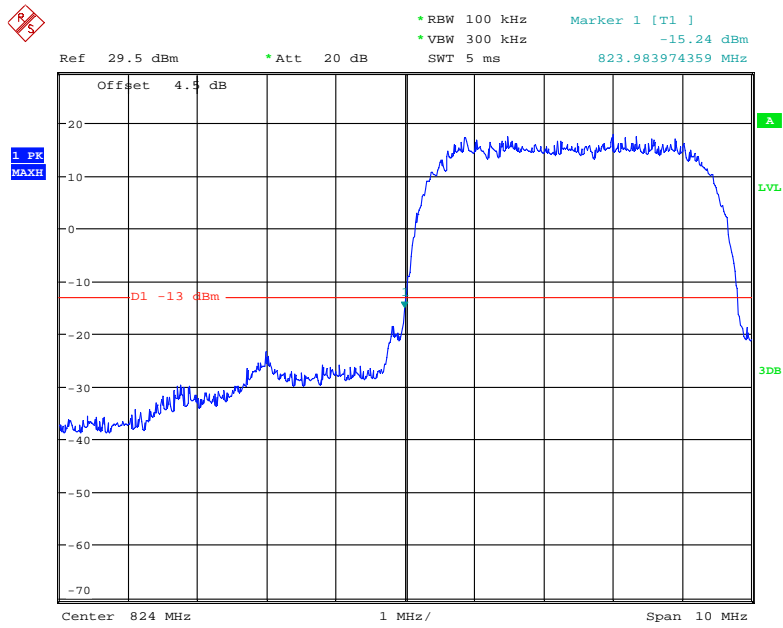

Date: 14.APR.2018 14:47:06

Cellular Band, Right Band Edge for WCDMA (BPSK) Mode

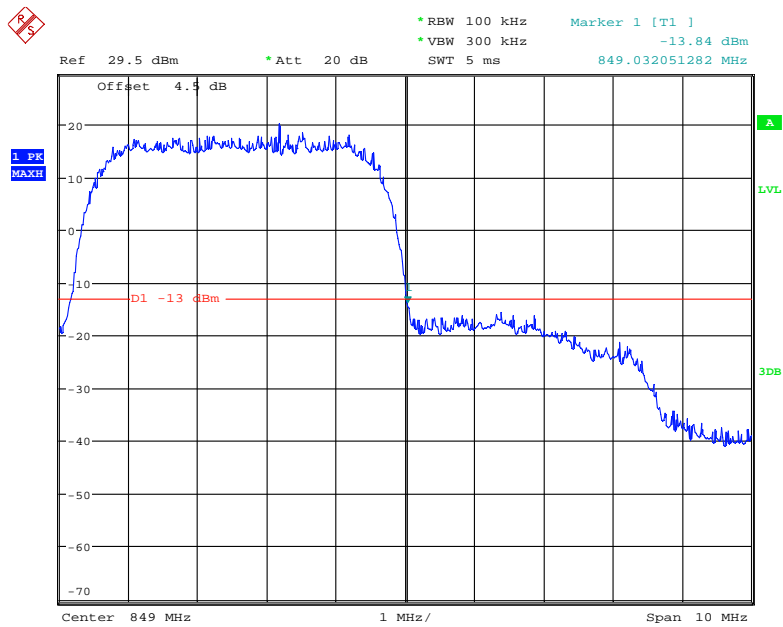

Date: 14.APR.2018 14:48:13

Cellular Band, Left Band Edge for HSDPA (16QAM) Mode

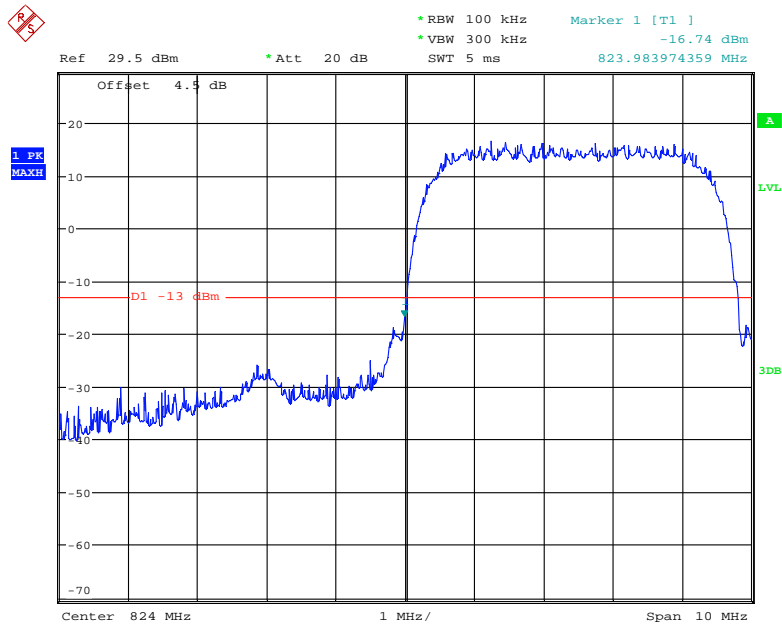

Date: 14.APR.2018 14:50:51

Cellular Band, Right Band Edge for HSDPA (16QAM) Mode

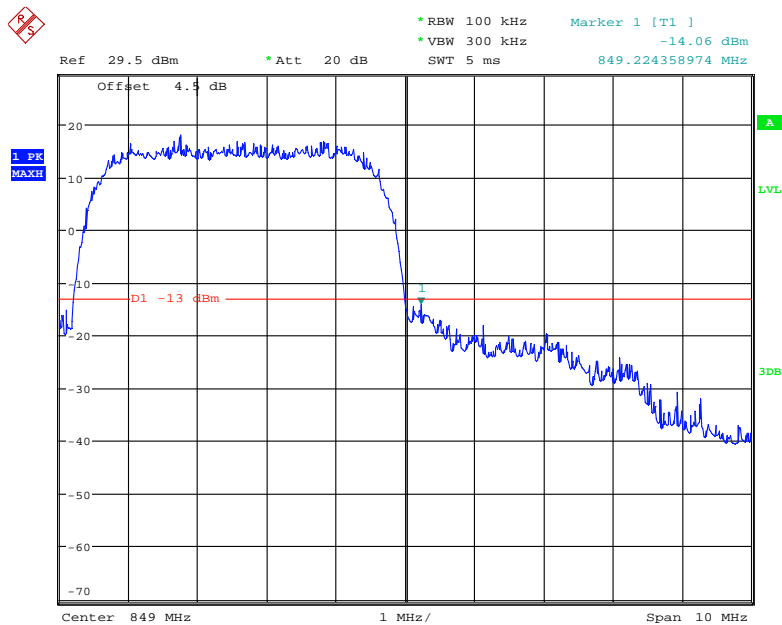

Date: 14.APR.2018 14:50:21

Cellular Band, Left Band Edge for HSUPA (BPSK) Mode

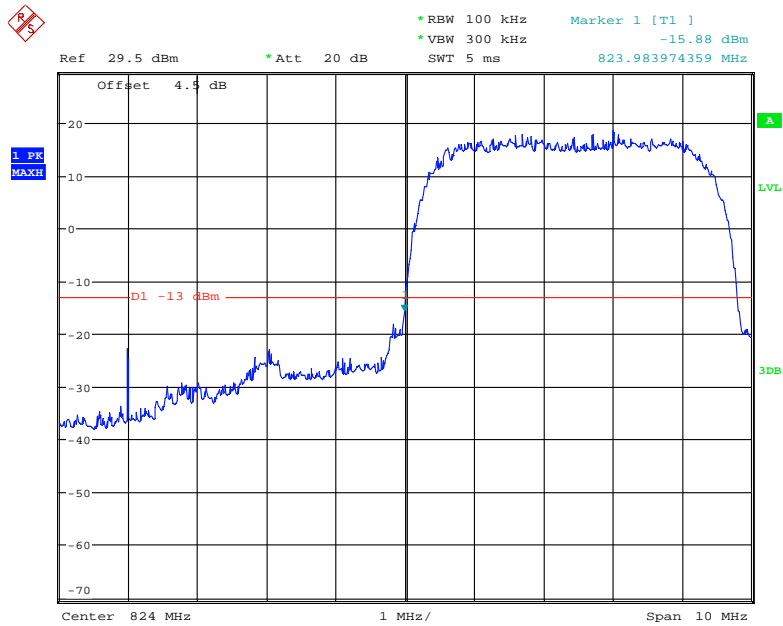

Date: 14.APR.2018 14:46:37

Cellular Band, Right Band Edge for HSUPA (BPSK) Mode

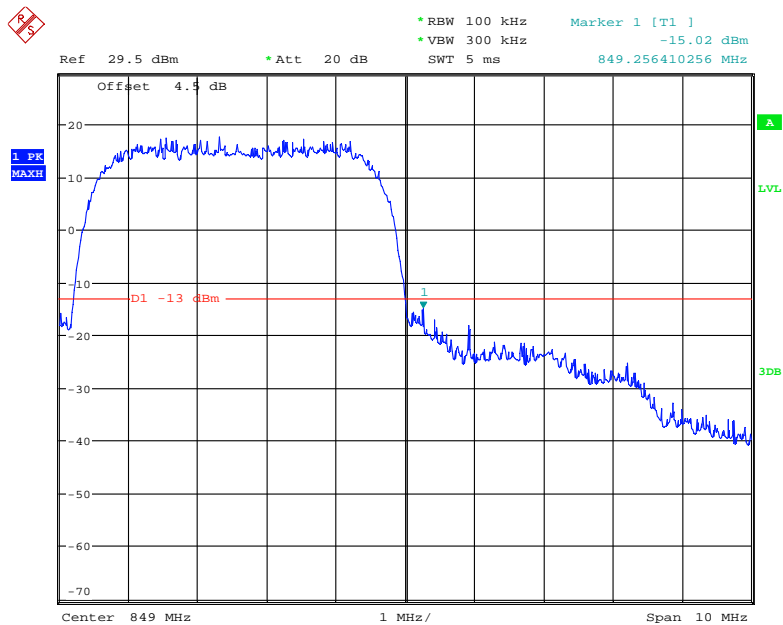

Date: 14.APR.2018 14:39:25

PCS Band, Left Band Edge for GSM (GMSK) Mode

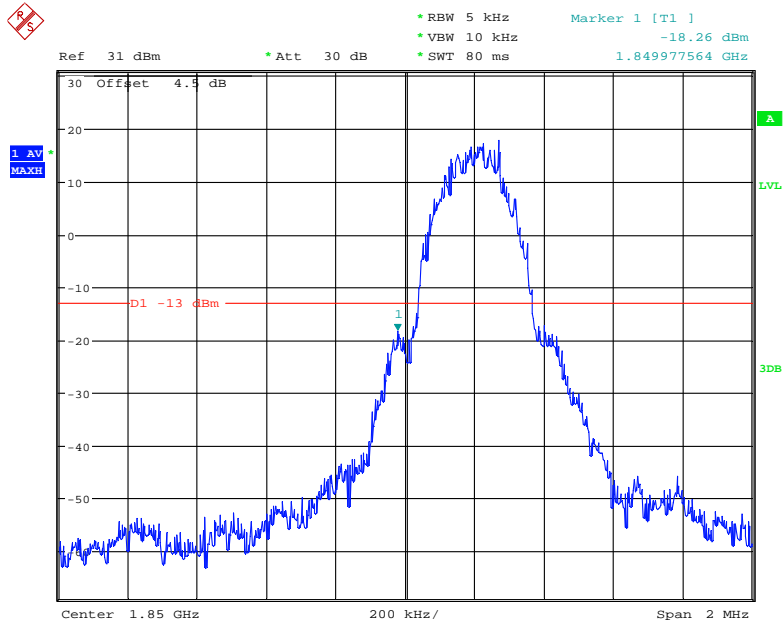

Date: 14.APR.2018 11:20:29

PCS Band, Right Band Edge for GSM (GMSK) Mode

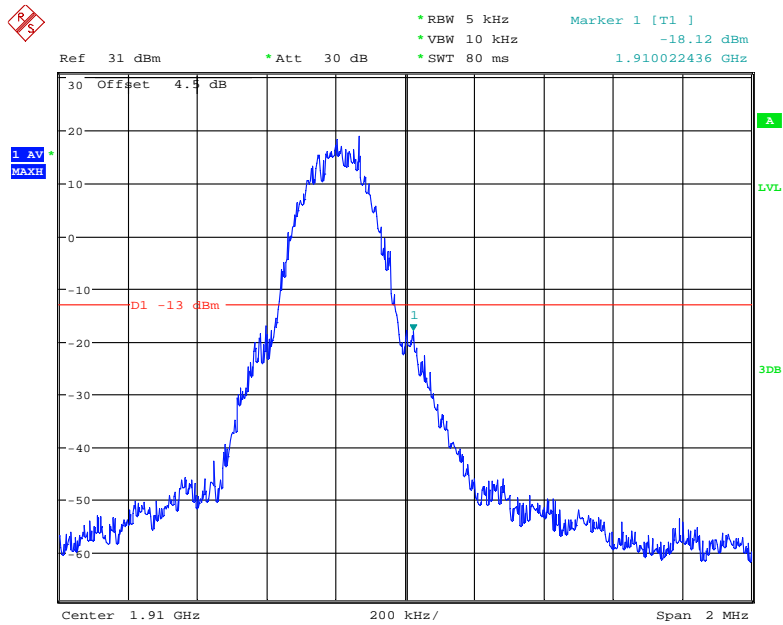

Date: 14.APR.2018 11:21:07

PCS Band, Left Band Edge for EDGE Mode

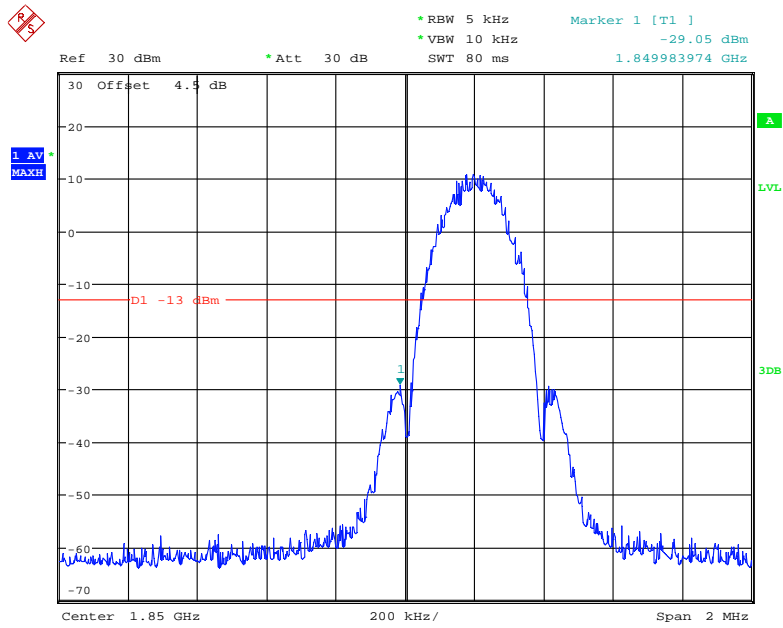

Date: 14.APR.2018 11:36:38

PCS Band, Right Band Edge for EDGE Mode

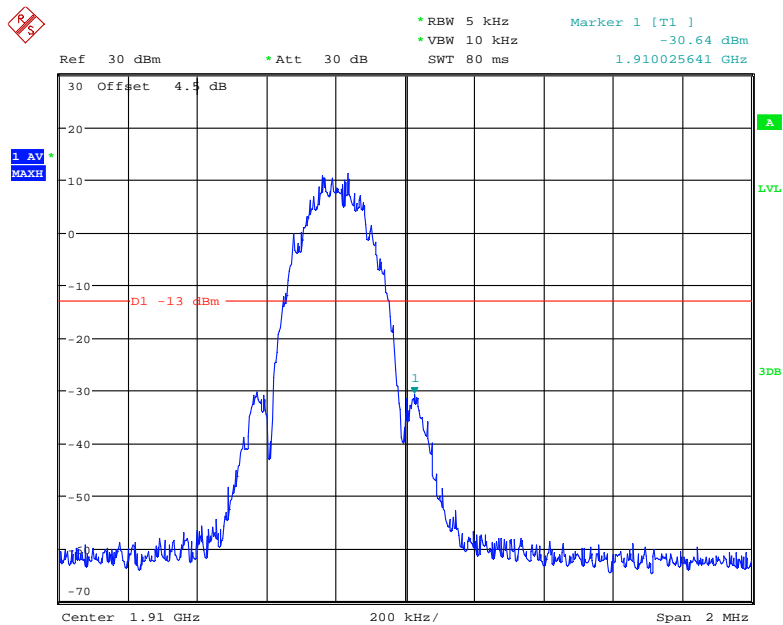

Date: 14.APR.2018 11:37:21

PCS Band, Left Band Edge for WCDMA (BPSK) Mode

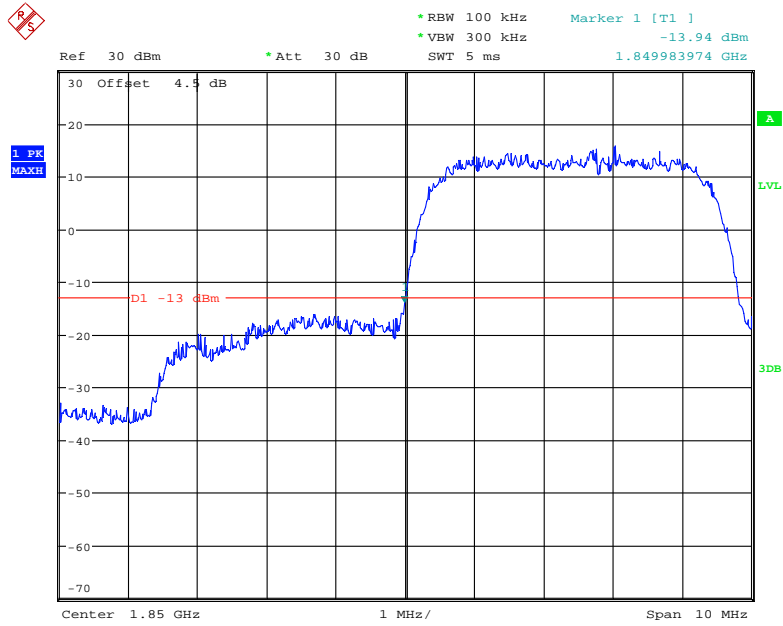

Date: 14.APR.2018 14:12:44

PCS Band, Right Band Edge for WCDMA (BPSK) Mode

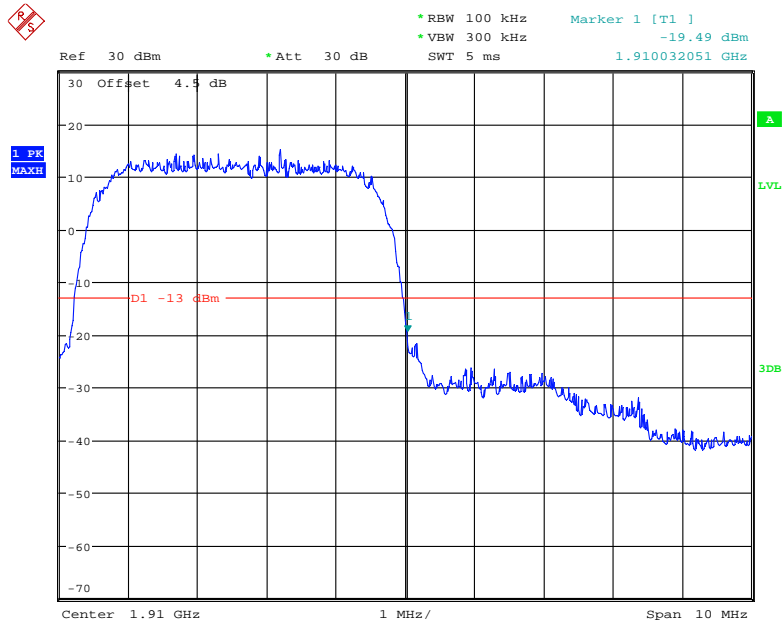

Date: 14.APR.2018 14:13:29

PCS Band, Left Band Edge for HSDPA (16QAM) Mode

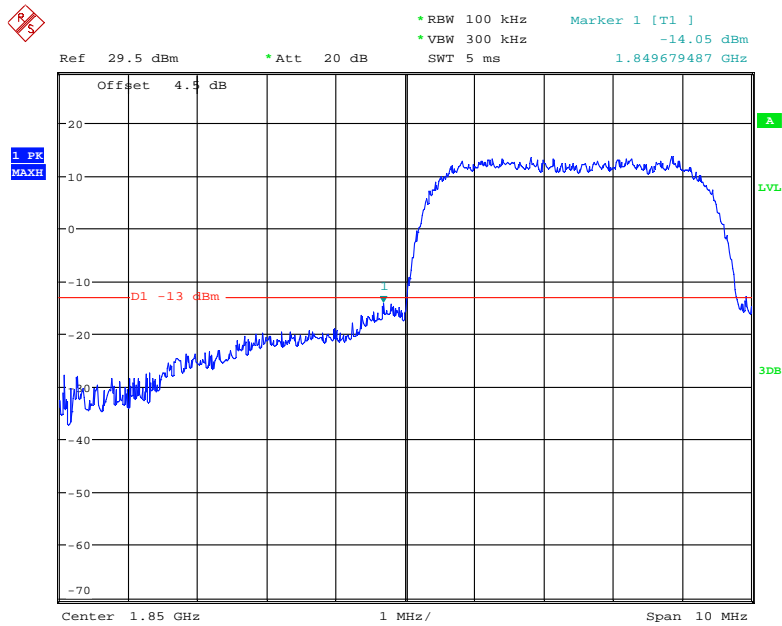

Date: 14.APR.2018 14:56:19

PCS Band, Right Band Edge for HSDPA (16QAM) Mode

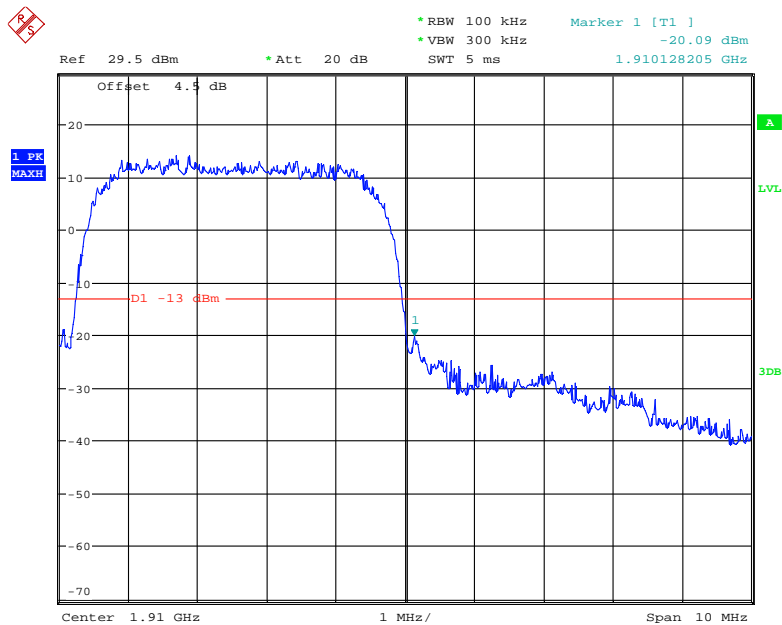

Date: 14.APR.2018 14:57:07

PCS Band, Left Band Edge for HSUPA (BPSK) Mode

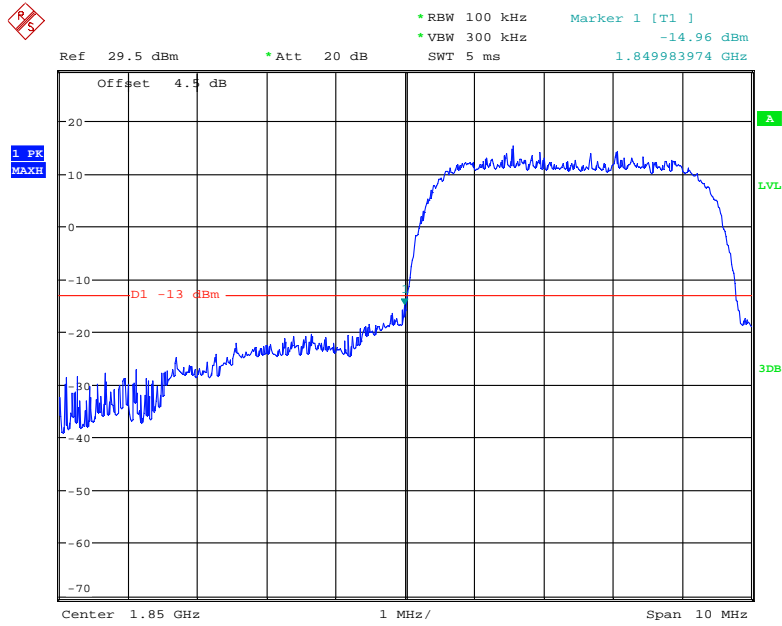

Date: 14.APR.2018 14:43:59

PCS Band, Right Band Edge for HSUPA (BPSK) Mode

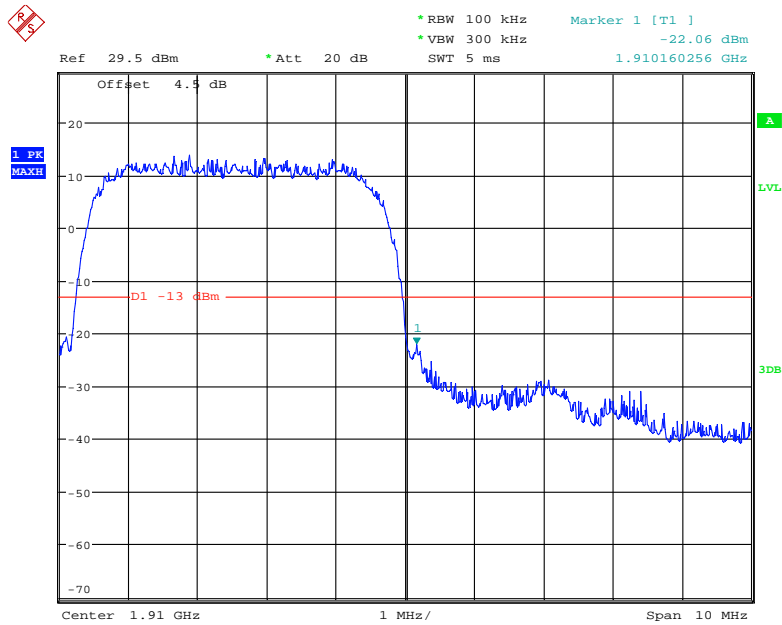

Date: 14.APR.2018 14:44:36

Band 2:

QPSK (1.4 MHz, FULL RB) - Left Band Edge

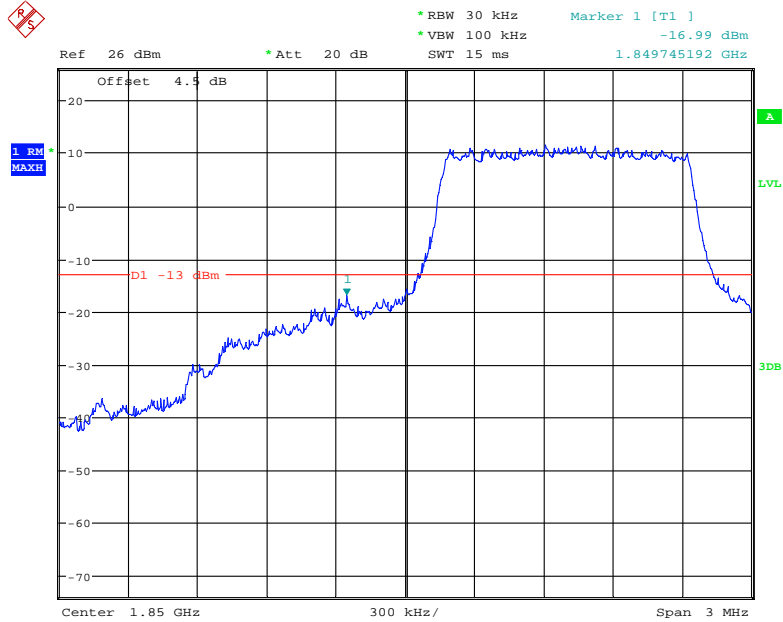

Date: 18.APR.2018 08:58:51

QPSK (1.4 MHz, FULL RB) - Right Band Edge

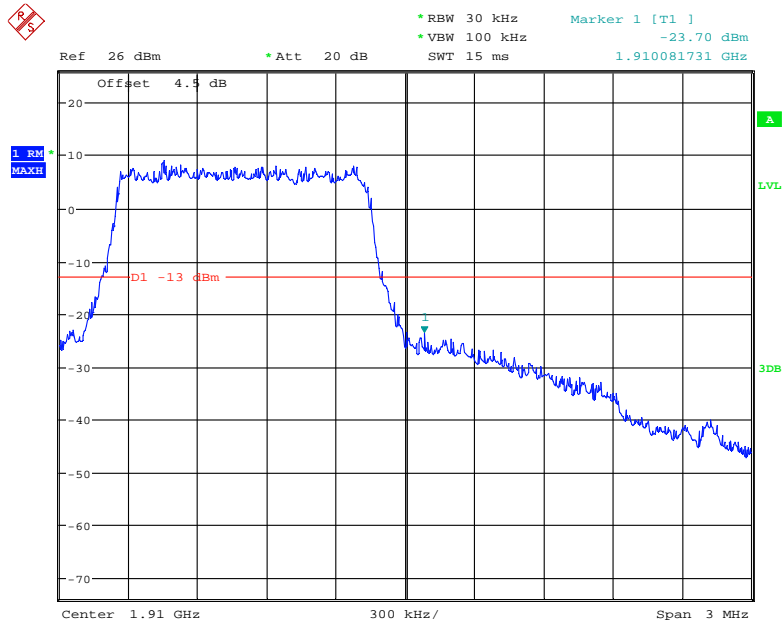

Date: 18.APR.2018 09:08:08

16-QAM (1.4 MHz, FULL RB) - Left Band Edge

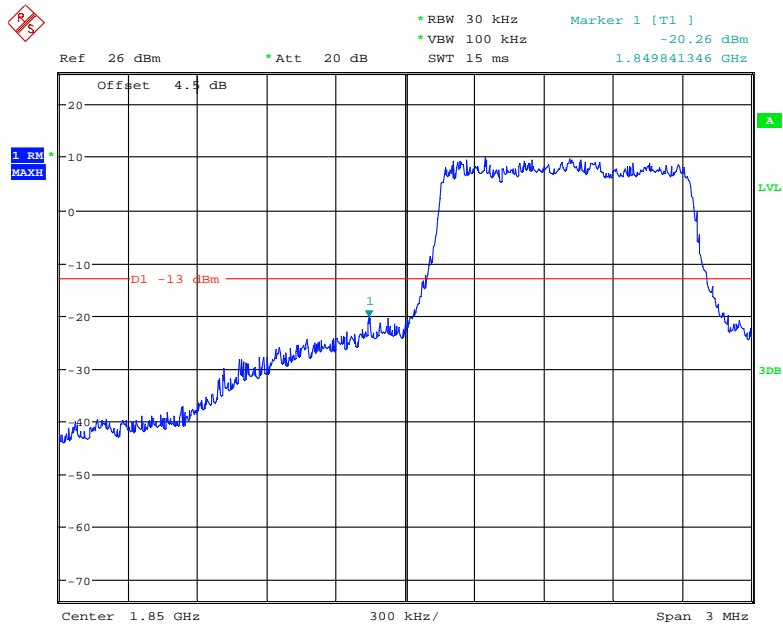

Date: 18.APR.2018 09:00:04

16-QAM (1.4 MHz, FULL RB) - Right Band Edge

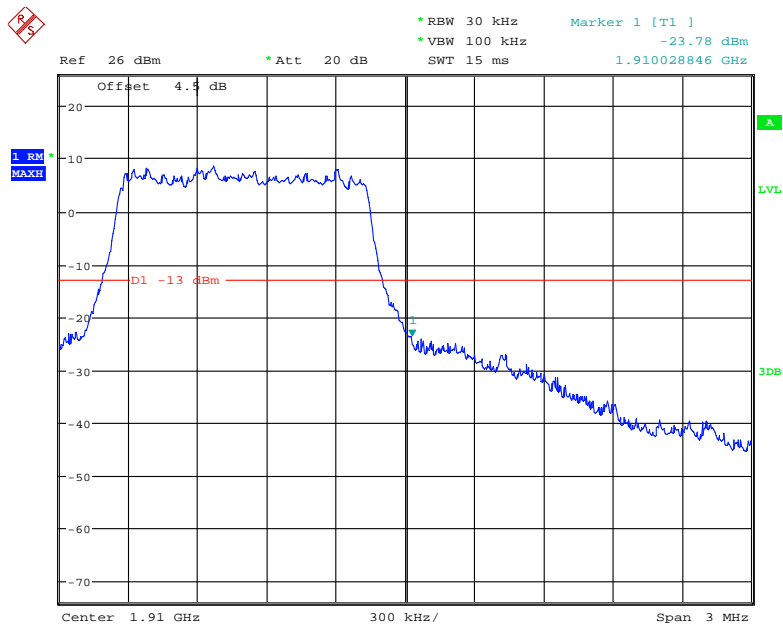

Date: 18.APR.2018 09:07:18

QPSK (3.0 MHz, FULL RB) - Left Band Edge

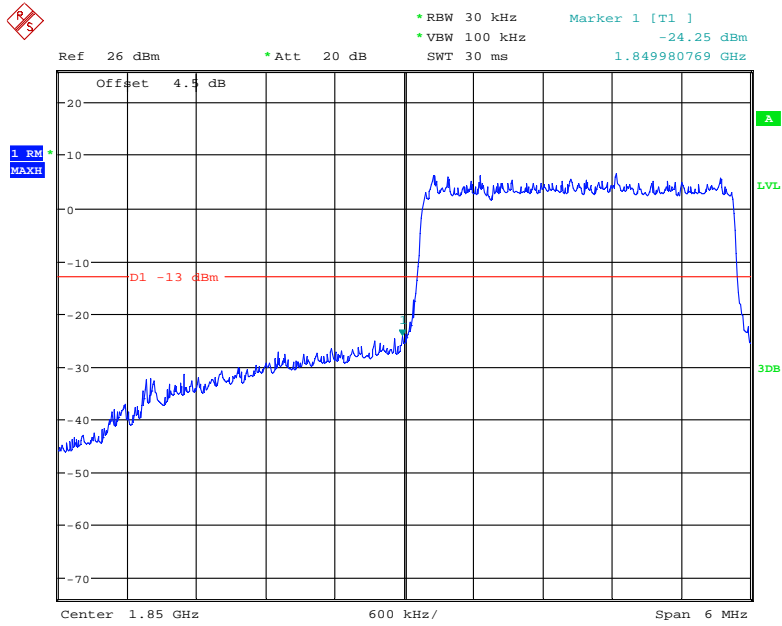

Date: 18.APR.2018 09:10:10

QPSK (3.0 MHz, FULL RB) - Right Band Edge

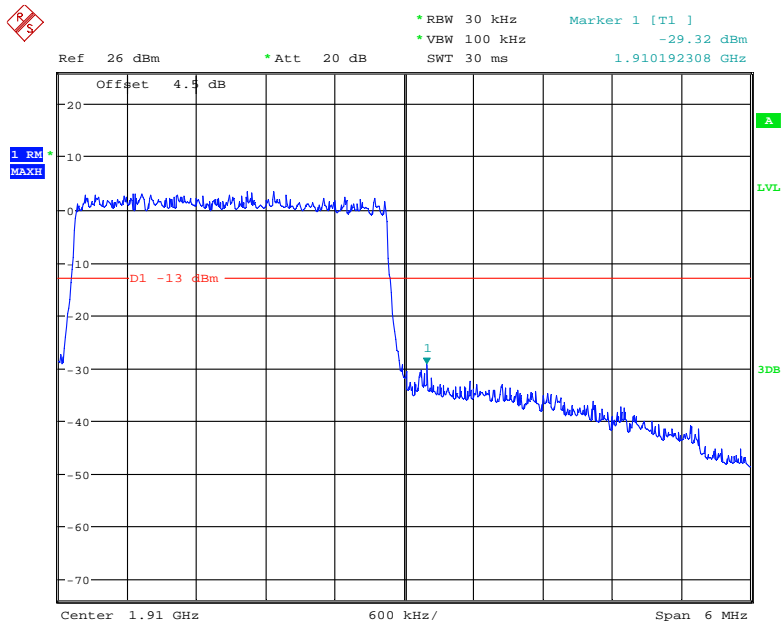

Date: 18.APR.2018 09:12:58

16-QAM (3.0 MHz, FULL RB) - Left Band Edge

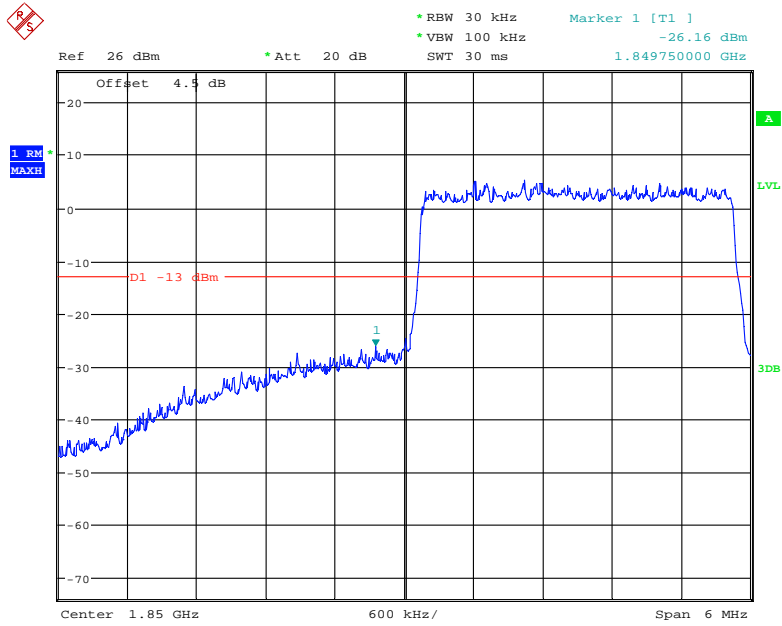

Date: 18.APR.2018 09:11:12

16-QAM (3.0 MHz, FULL RB) - Right Band Edge

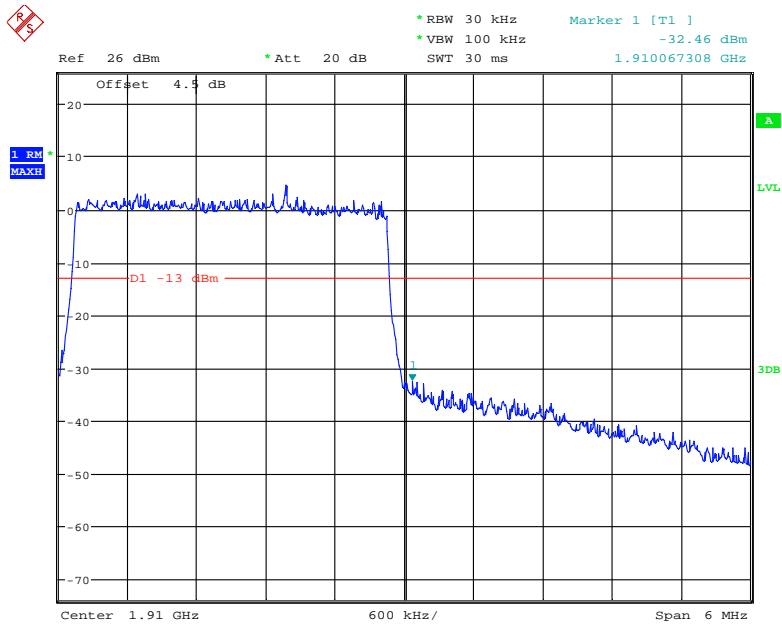

Date: 18.APR.2018 09:12:26

QPSK (5.0 MHz, FULL RB) - Left Band Edge

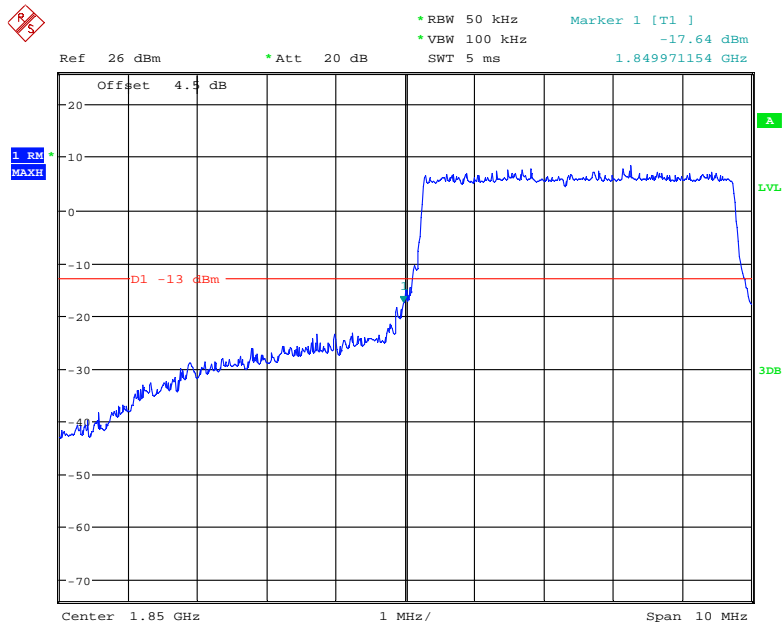

Date: 18.APR.2018 09:15:33

QPSK (5.0 MHz, FULL RB) - Right Band Edge

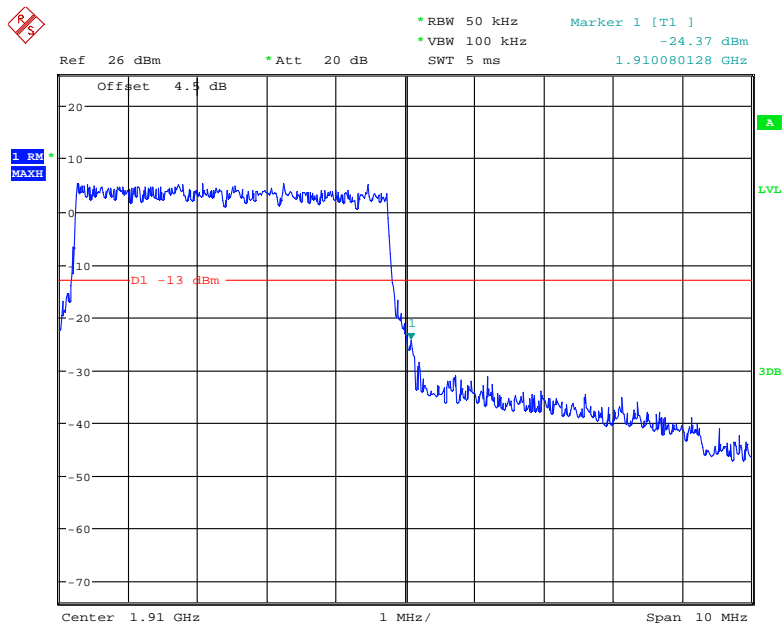

Date: 18.APR.2018 09:18:34

16-QAM (5.0 MHz, FULL RB) - Left Band Edge

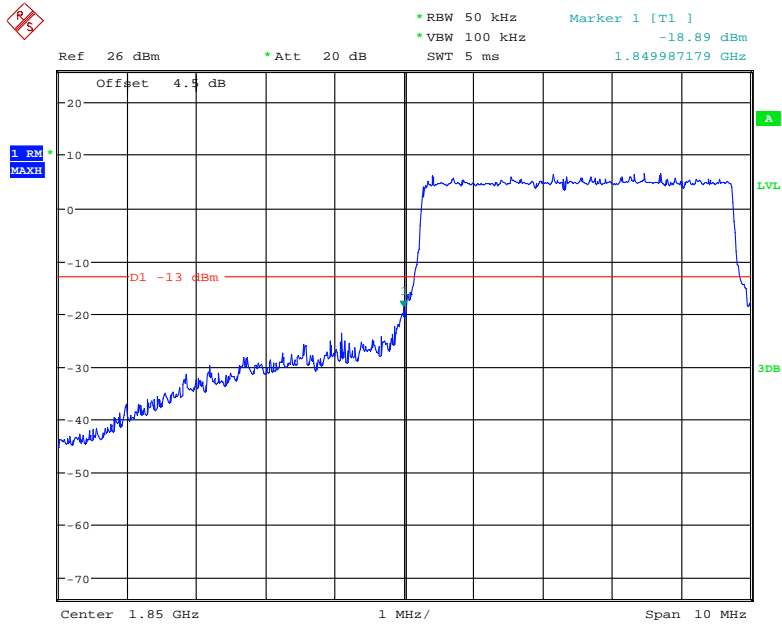

Date: 18.APR.2018 09:16:25

16-QAM (5.0 MHz, FULL RB) - Right Band Edge

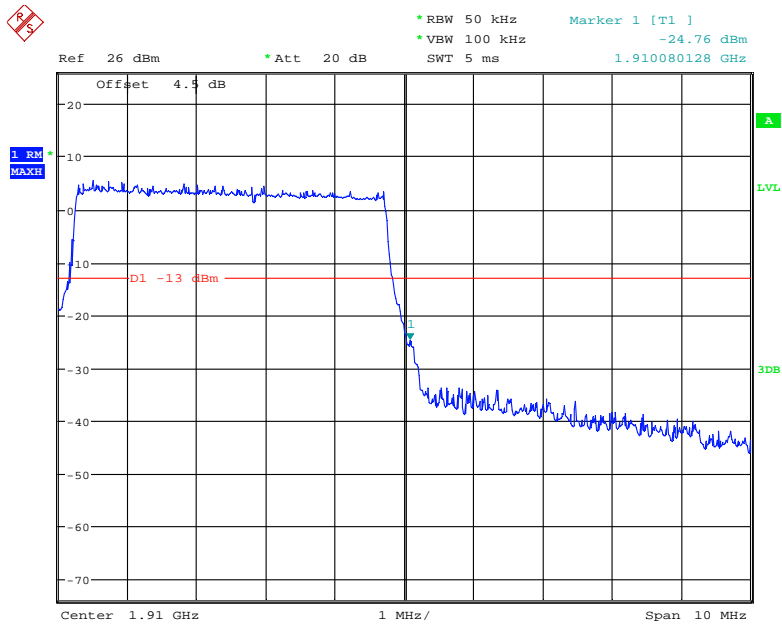

Date: 18.APR.2018 09:18:02

QPSK (10.0 MHz, FULL RB) - Left Band Edge

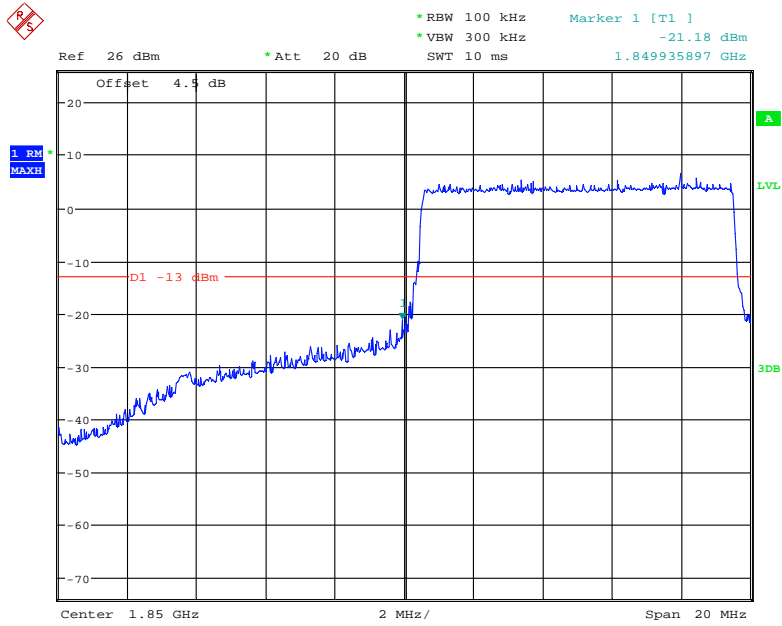

Date: 18.APR.2018 09:21:24

QPSK (10.0 MHz, FULL RB) - Right Band Edge

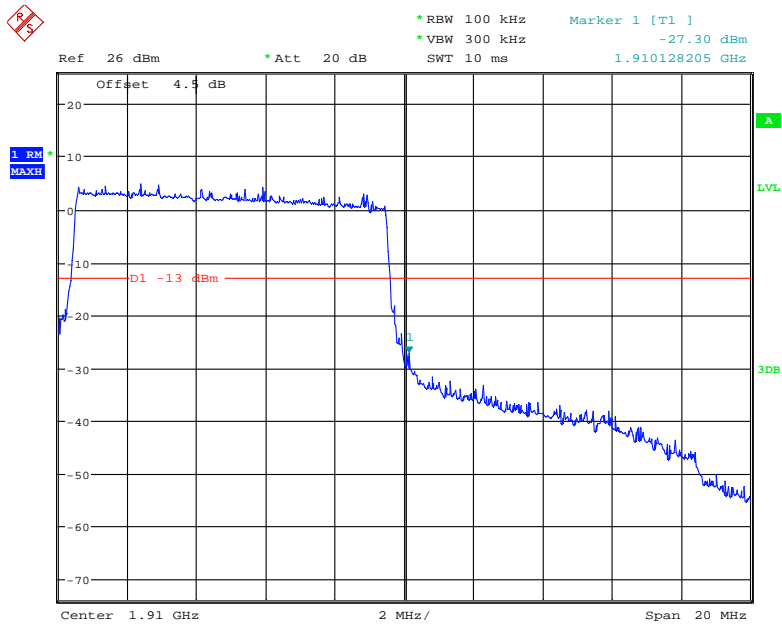

Date: 18.APR.2018 09:22:46

16-QAM (10.0 MHz, FULL RB) - Left Band Edge

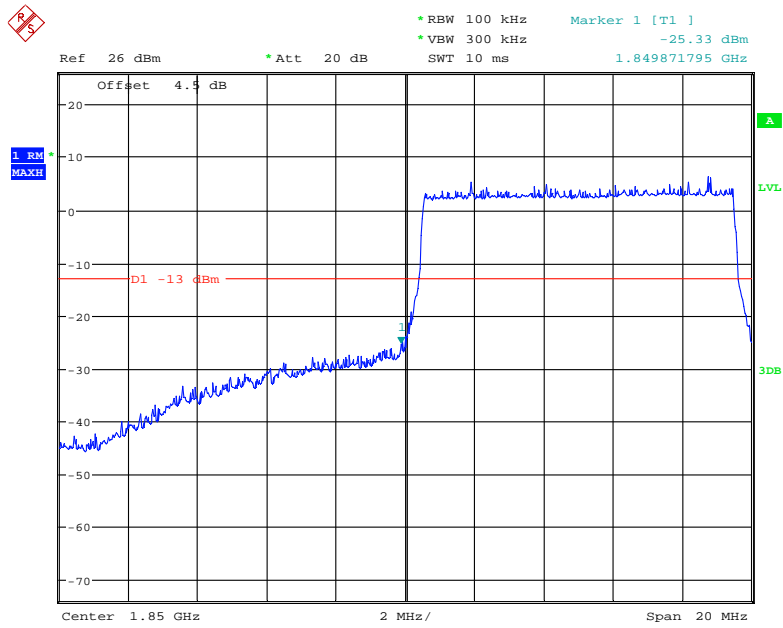

Date: 18.APR.2018 09:20:41

16-QAM (10.0 MHz, FULL RB) - Right Band Edge

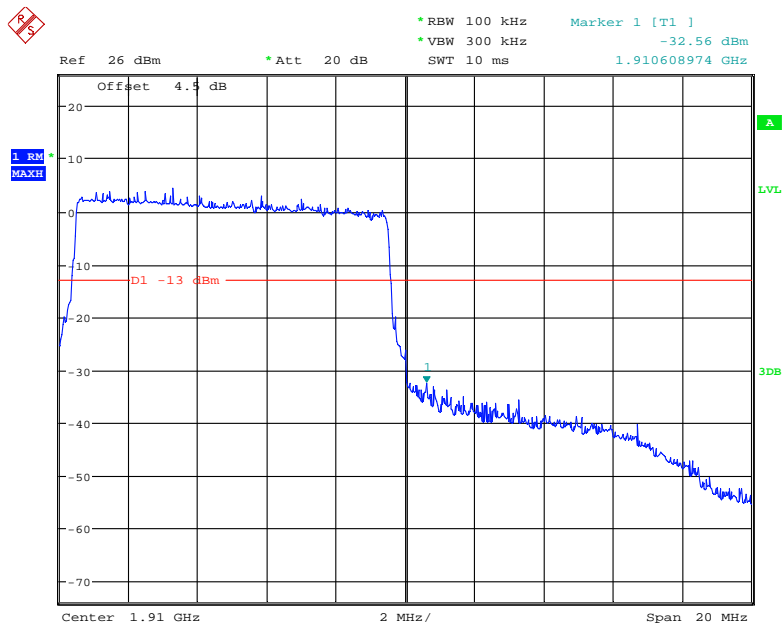

Date: 18.APR.2018 09:23:33

QPSK (15.0 MHz, FULL RB) - Left Band Edge

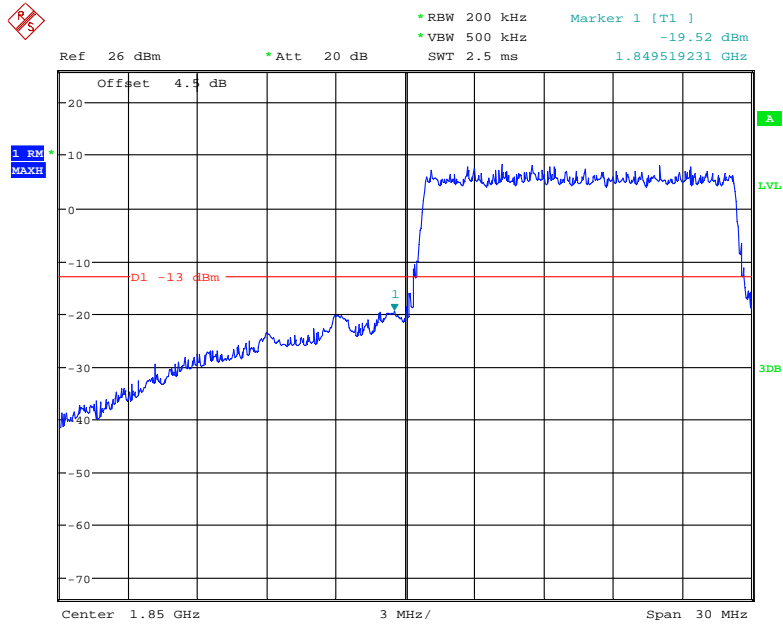

Date: 18.APR.2018 09:25:28

QPSK (15.0 MHz, FULL RB) - Right Band Edge

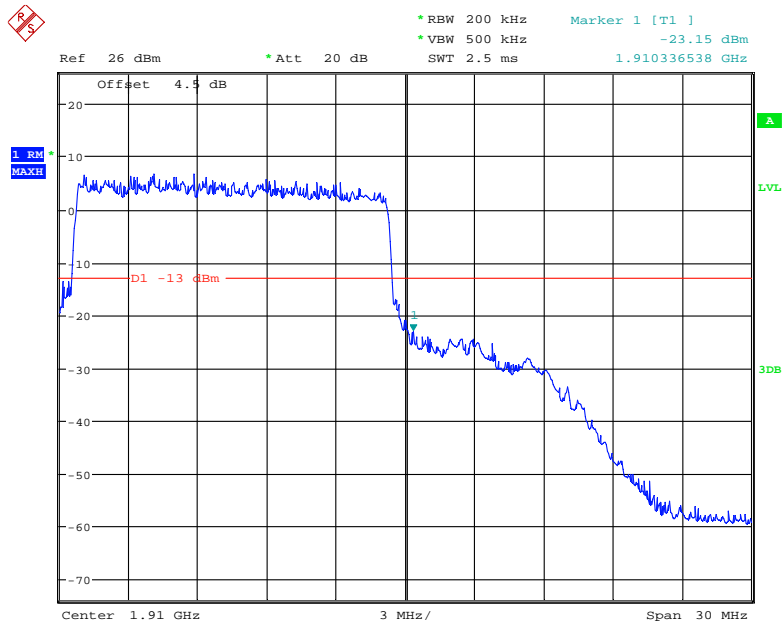

Date: 18.APR.2018 09:28:28

16-QAM (15.0 MHz, FULL RB) - Left Band Edge

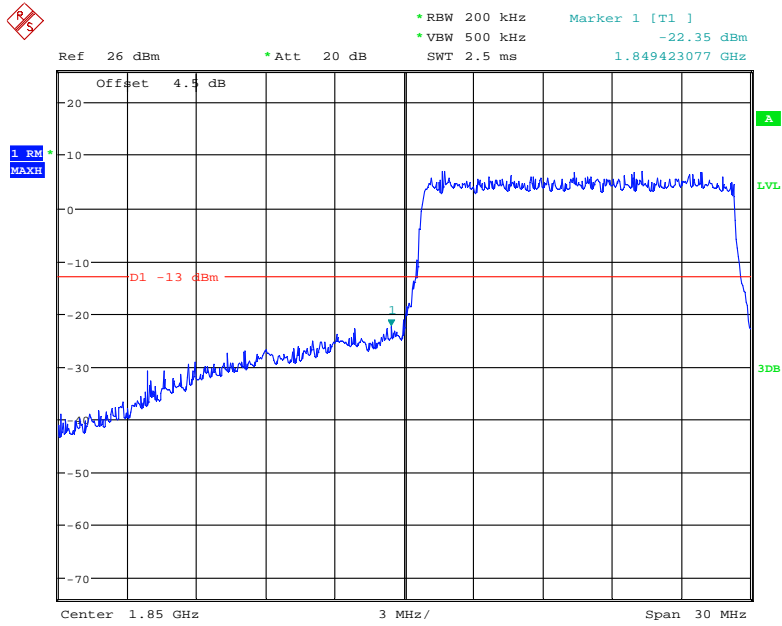

Date: 18.APR.2018 09:26:17

16-QAM (15.0 MHz, FULL RB) - Right Band Edge

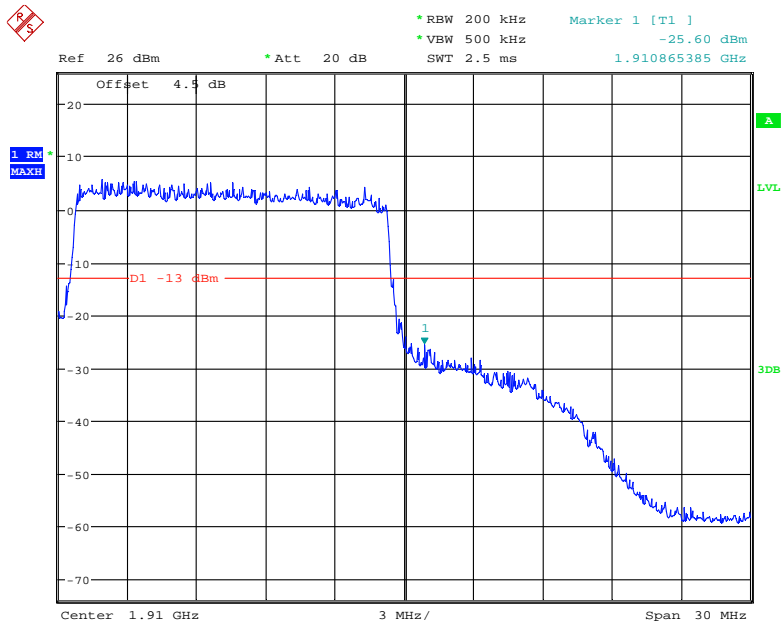

Date: 18.APR.2018 09:27:44

QPSK (20.0 MHz, FULL RB) - Left Band Edge

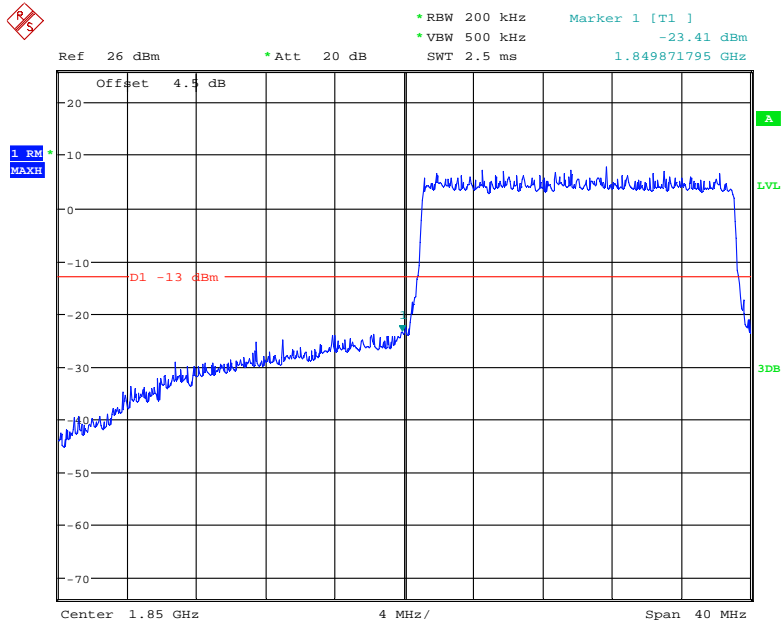

Date: 18.APR.2018 09:30:18

QPSK (20.0 MHz, FULL RB) - Right Band Edge

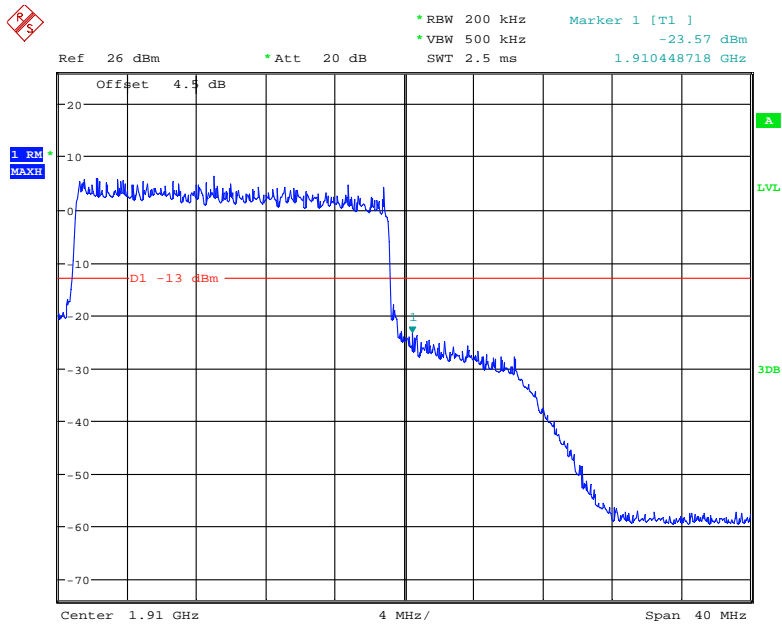

Date: 18.APR.2018 09:32:45

16-QAM (20.0 MHz, FULL RB) - Left Band Edge

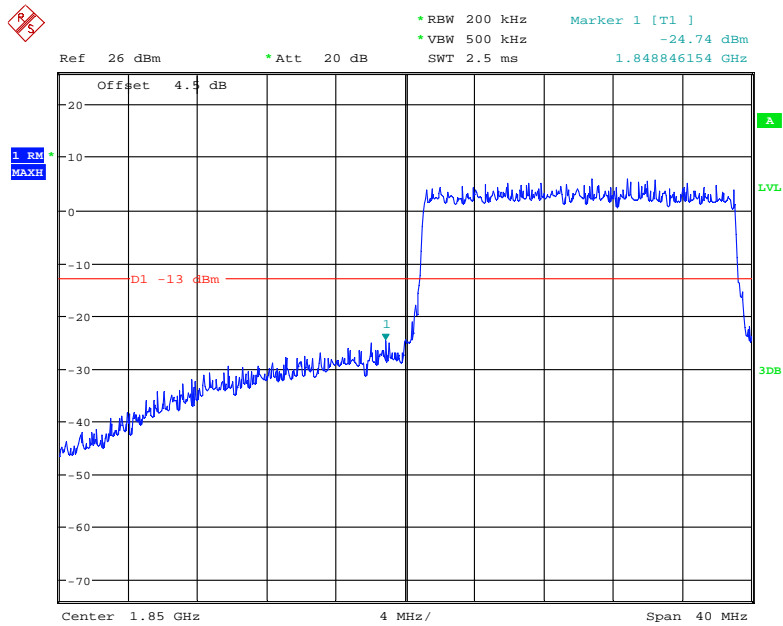

Date: 18.APR.2018 09:30:52

16-QAM (20.0 MHz, FULL RB) - Right Band Edge

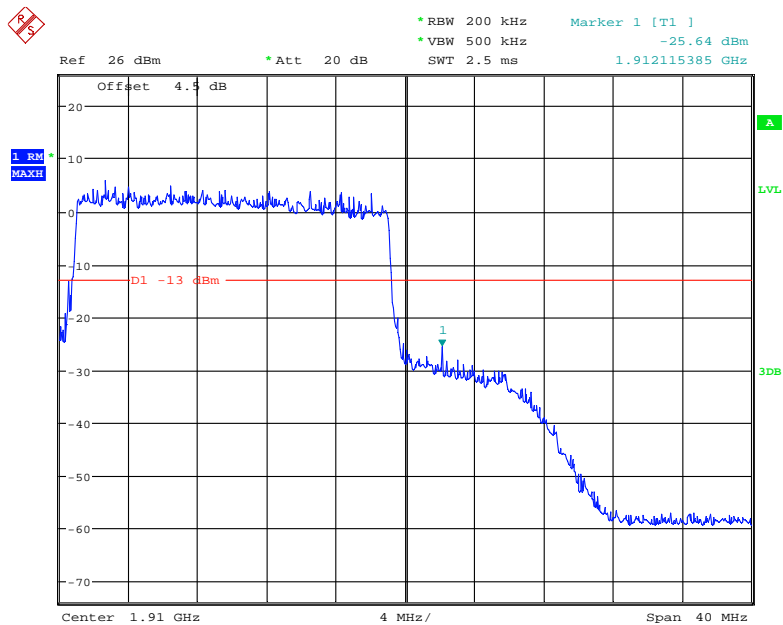

Date: 18.APR.2018 09:31:49

Band 4:

QPSK (1.4 MHz, FULL RB) - Left Band Edge

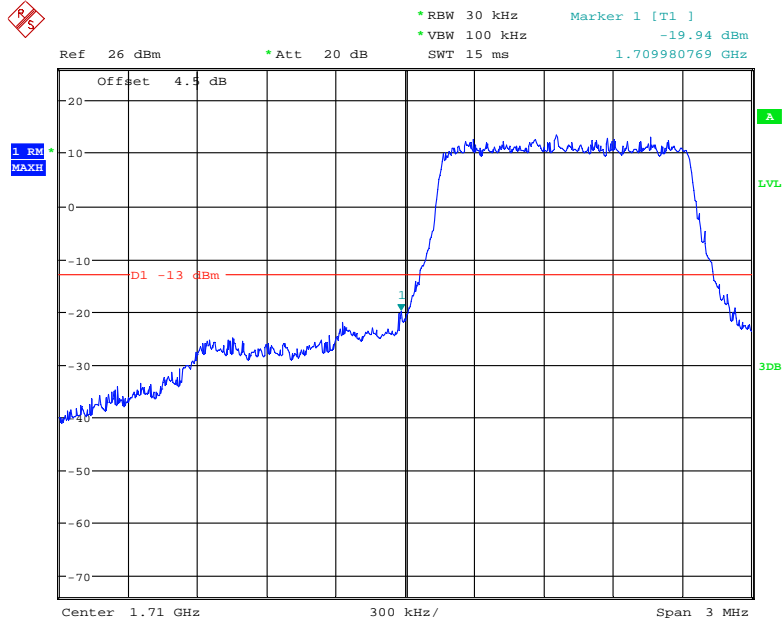

Date: 18.APR.2018 09:36:27

QPSK (1.4 MHz, FULL RB) - Right Band Edge

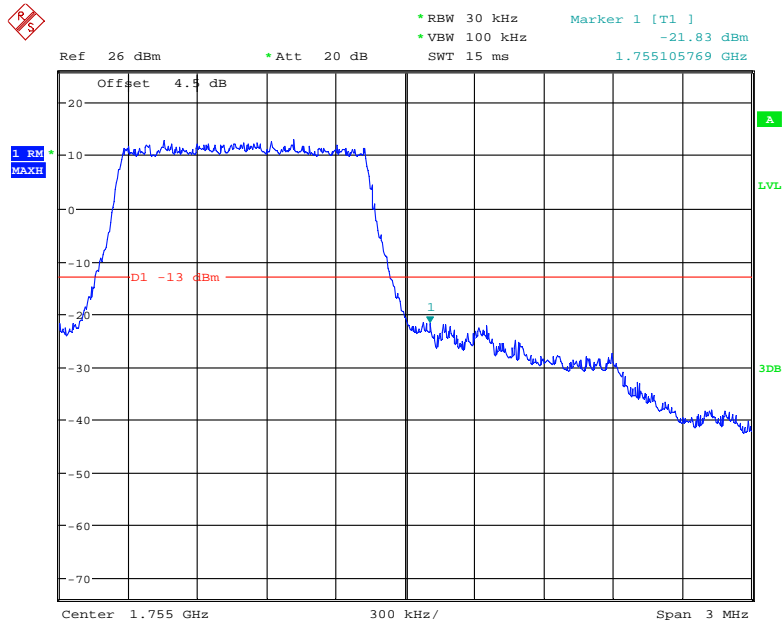

Date: 18.APR.2018 10:51:19

16-QAM (1.4 MHz, FULL RB) - Left Band Edge

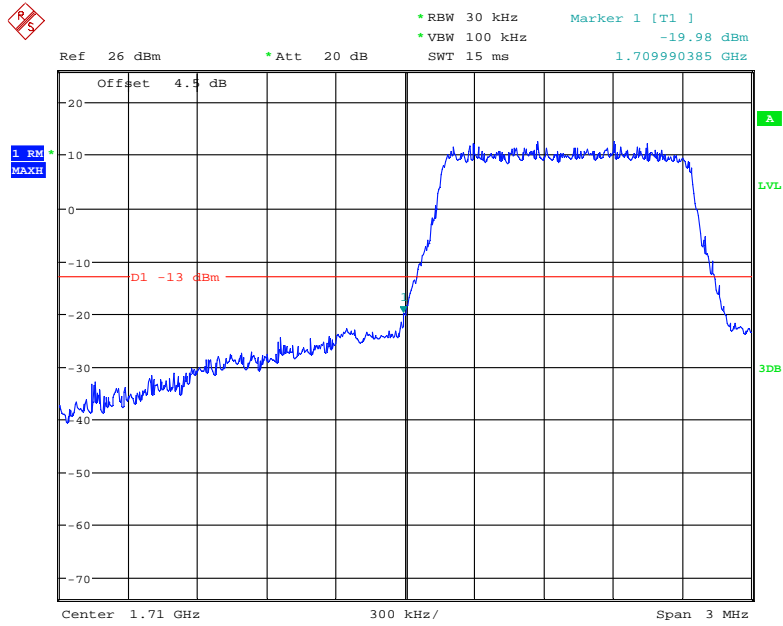

Date: 18.APR.2018 09:37:23

16-QAM (1.4 MHz, FULL RB) - Right Band Edge

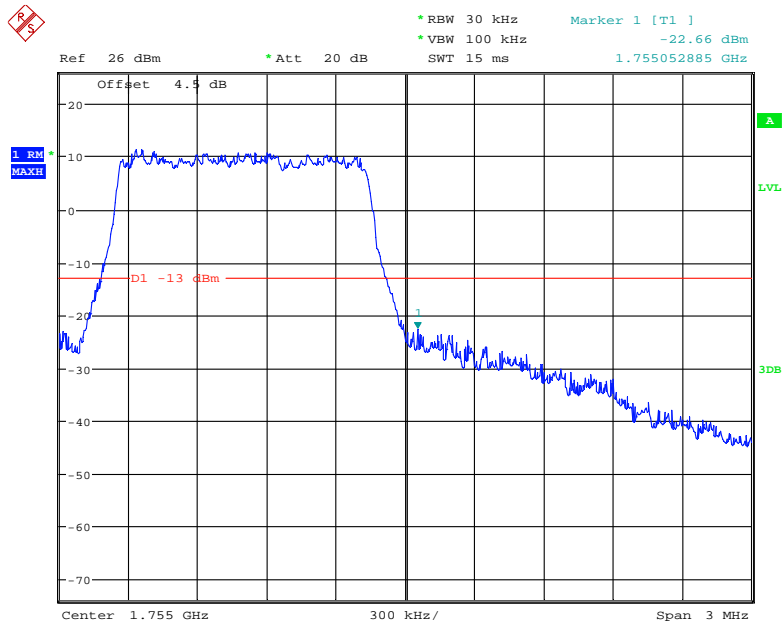

Date: 18.APR.2018 09:38:35

QPSK (3.0 MHz, FULL RB) - Left Band Edge

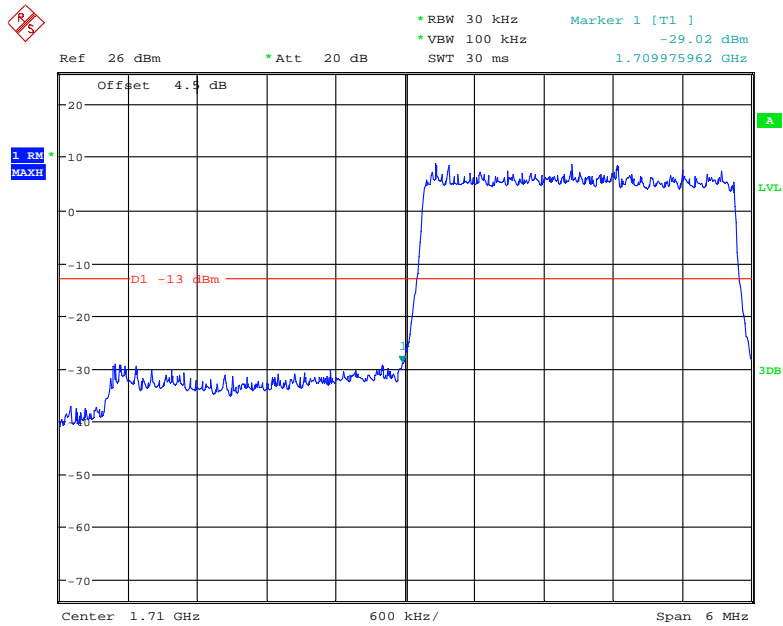

Date: 18.APR.2018 09:42:09

QPSK (3.0 MHz, FULL RB) - Right Band Edge

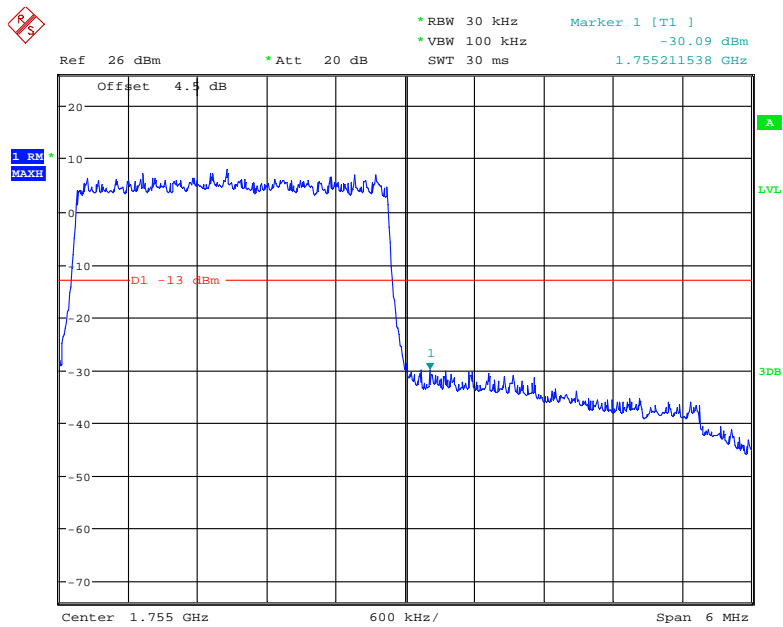

Date: 18.APR.2018 09:45:32

16-QAM (3.0 MHz, FULL RB) - Left Band Edge

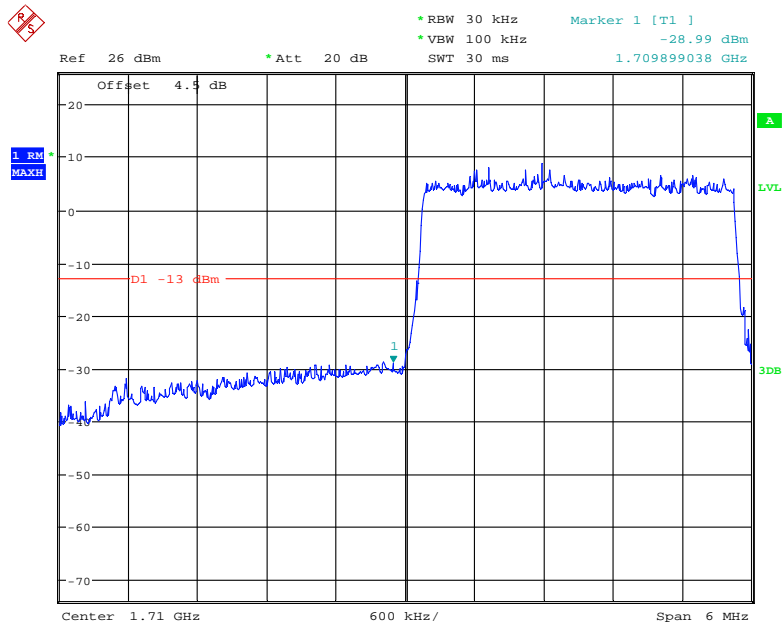

Date: 18.APR.2018 09:42:46

16-QAM (3.0 MHz, FULL RB) - Right Band Edge

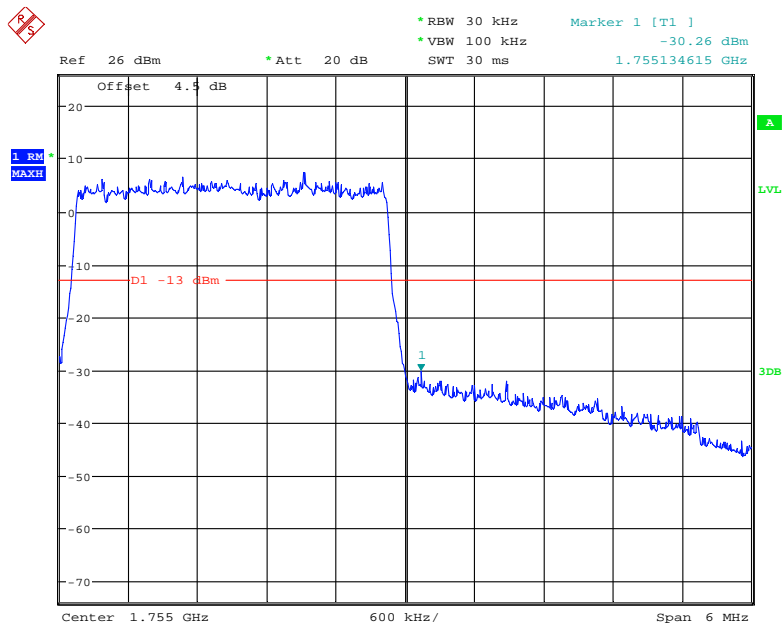

Date: 18.APR.2018 09:44:56

QPSK (5.0 MHz, FULL RB) - Left Band Edge

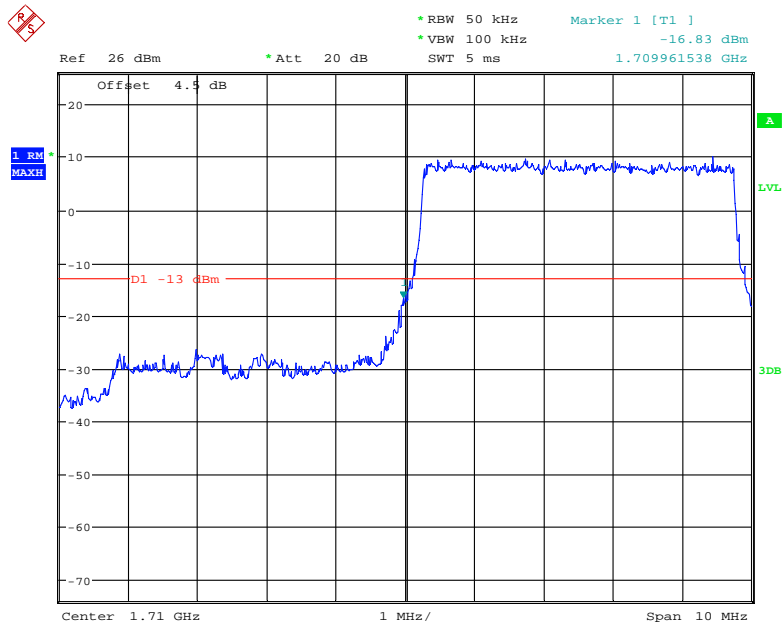

Date: 18.APR.2018 10:54:00

QPSK (5.0 MHz, FULL RB) - Right Band Edge

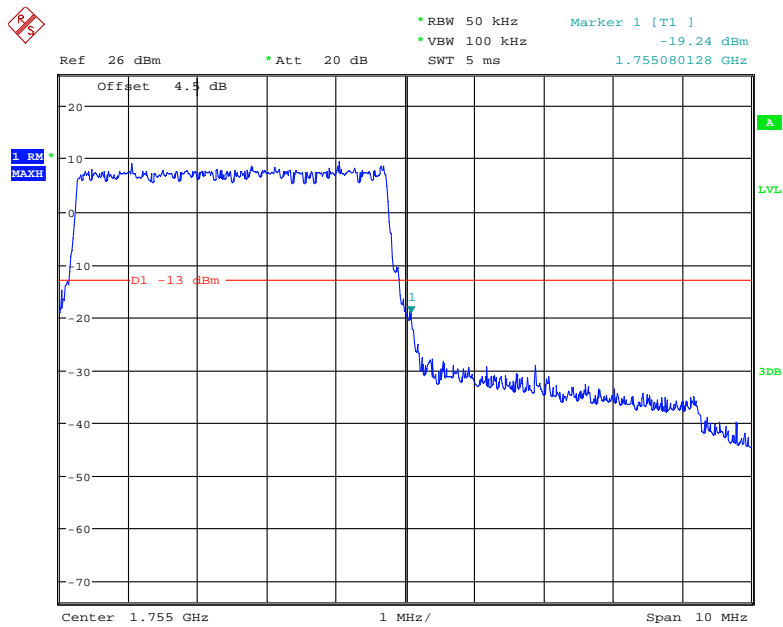

Date: 18.APR.2018 10:56:00

16-QAM (5.0 MHz, FULL RB) - Left Band Edge

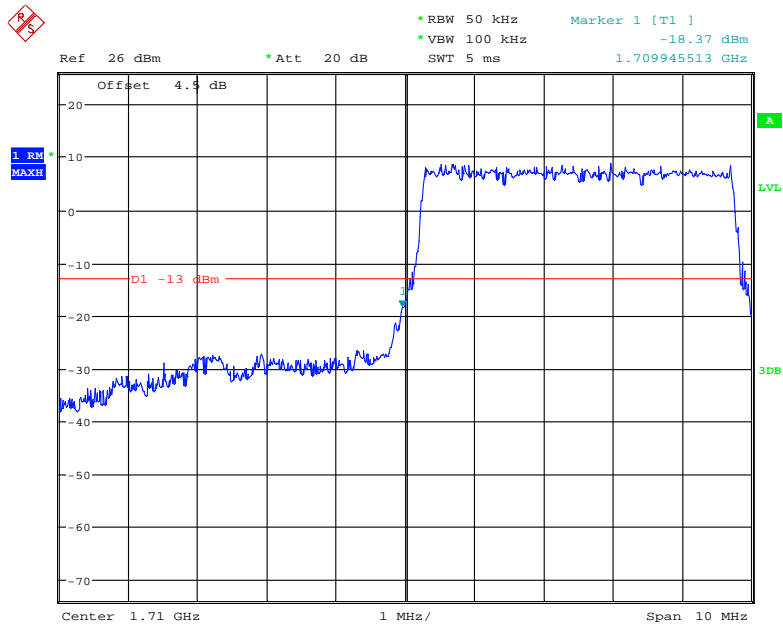

Date: 18.APR.2018 10:54:30

16-QAM (5.0 MHz, FULL RB) - Right Band Edge

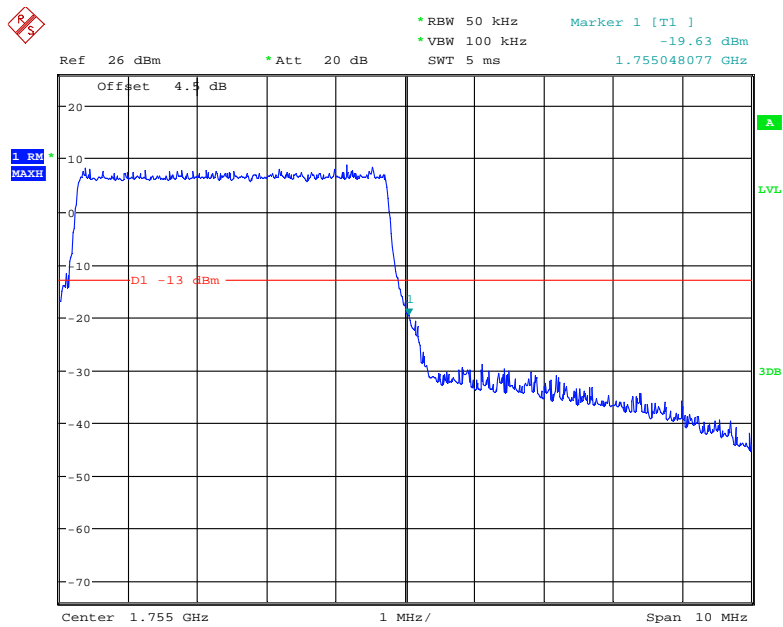

Date: 18.APR.2018 10:55:33

QPSK (10.0 MHz, FULL RB) - Left Band Edge

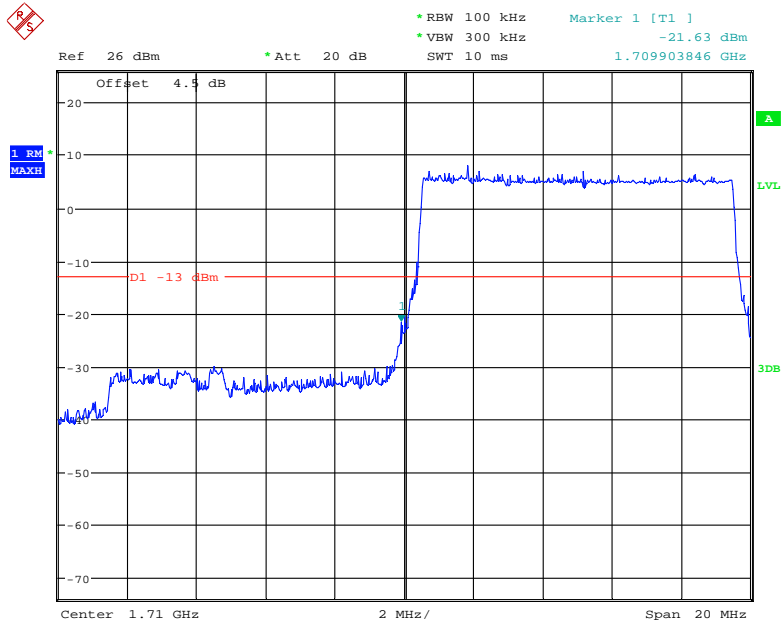

Date: 18.APR.2018 09:51:25

QPSK (10.0 MHz, FULL RB) - Right Band Edge

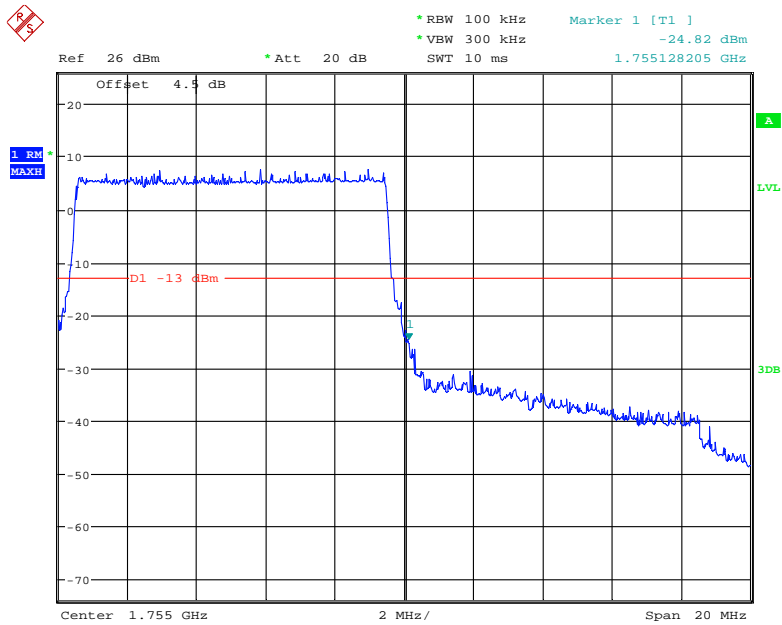

Date: 18.APR.2018 09:52:28

16-QAM (10.0 MHz, FULL RB) - Left Band Edge

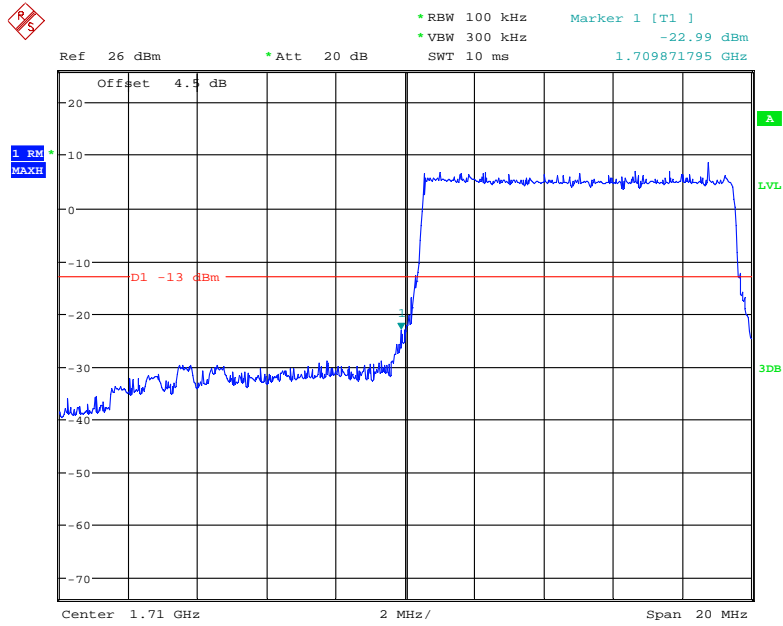

Date: 18.APR.2018 09:50:47

16-QAM (10.0 MHz, FULL RB) - Right Band Edge

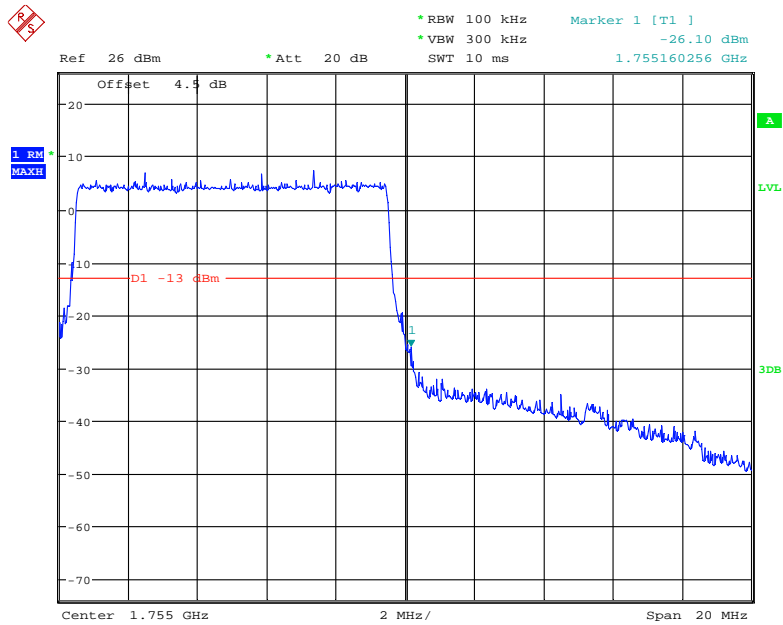

Date: 18.APR.2018 09:52:58

QPSK (15.0 MHz, FULL RB) - Left Band Edge

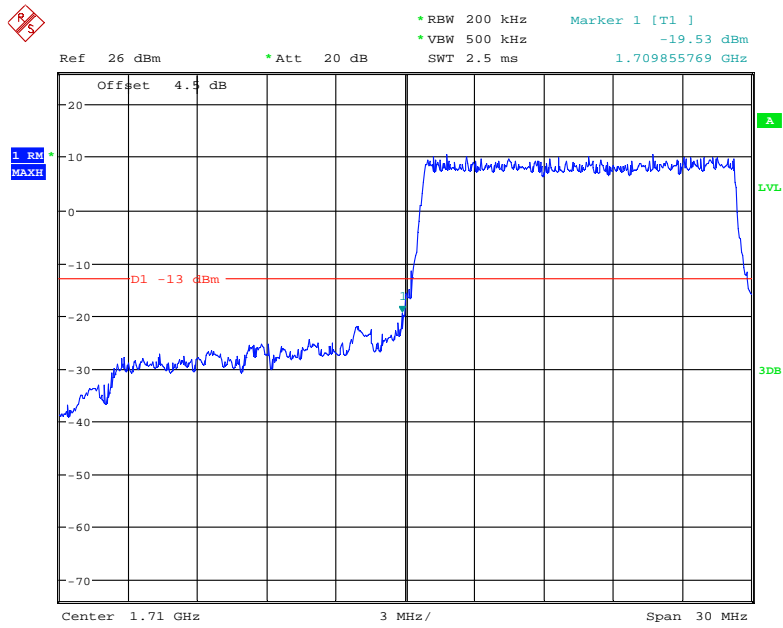

Date: 18.APR.2018 09:55:21

QPSK (15.0 MHz, FULL RB) - Right Band Edge

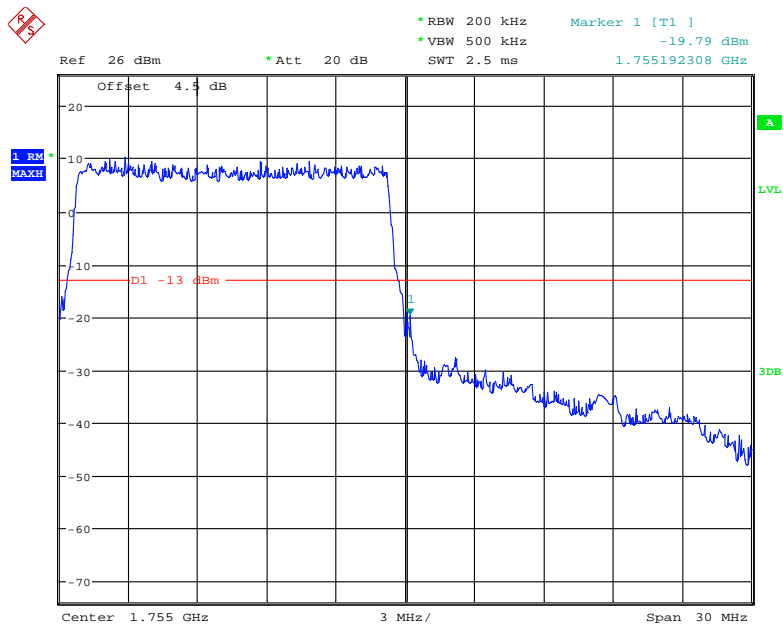

Date: 18.APR.2018 09:57:35

16-QAM (15.0 MHz, FULL RB) - Left Band Edge

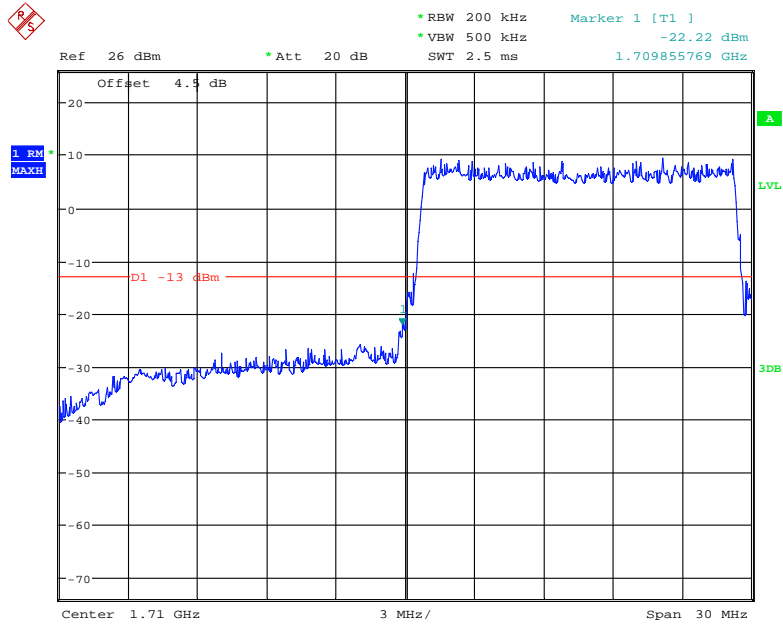

Date: 18.APR.2018 09:55:51

16-QAM (15.0 MHz, FULL RB) - Right Band Edge

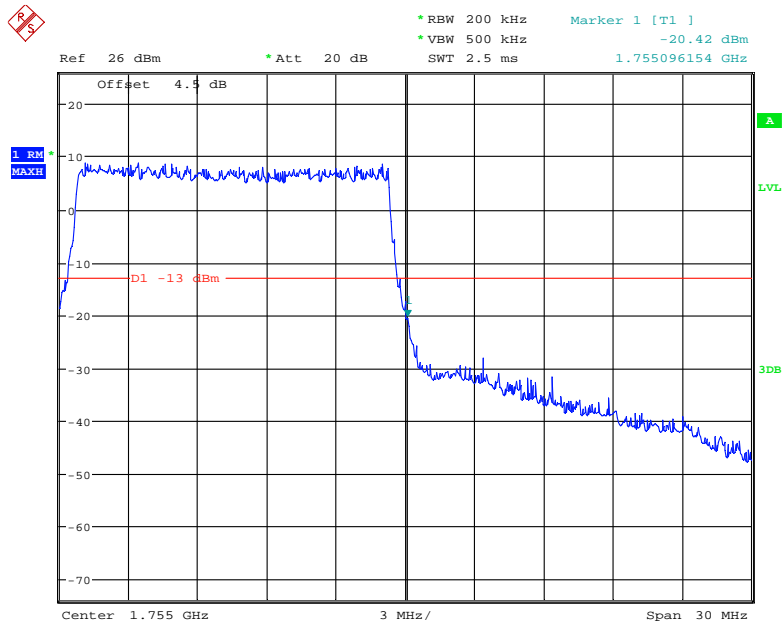

Date: 18.APR.2018 09:56:51

QPSK (20.0 MHz, FULL RB) - Left Band Edge

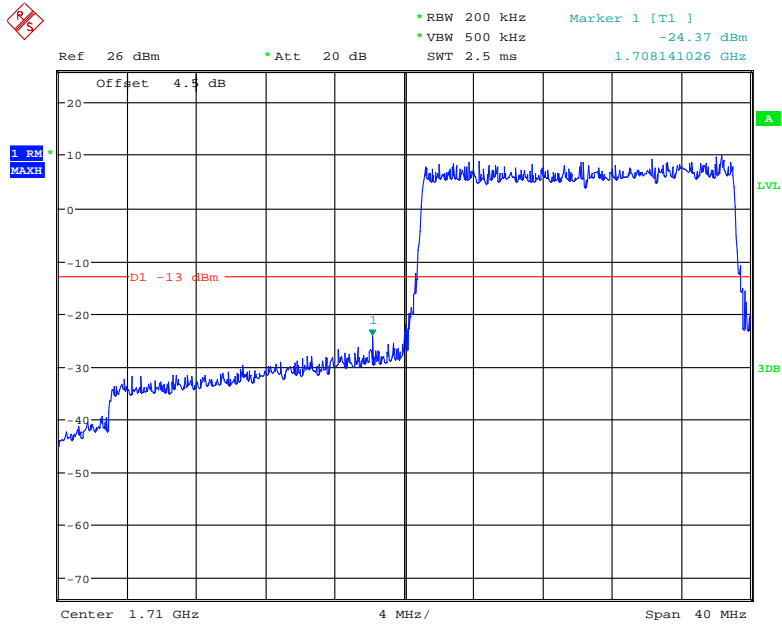

Date: 18.APR.2018 09:59:34

QPSK (20.0 MHz, FULL RB) - Right Band Edge

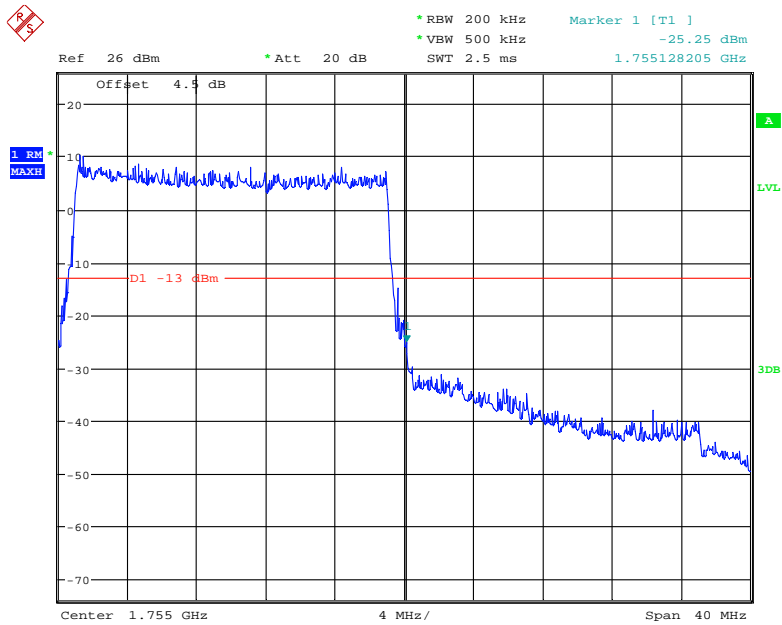

Date: 18.APR.2018 10:01:29

16-QAM (20.0 MHz, FULL RB) - Left Band Edge

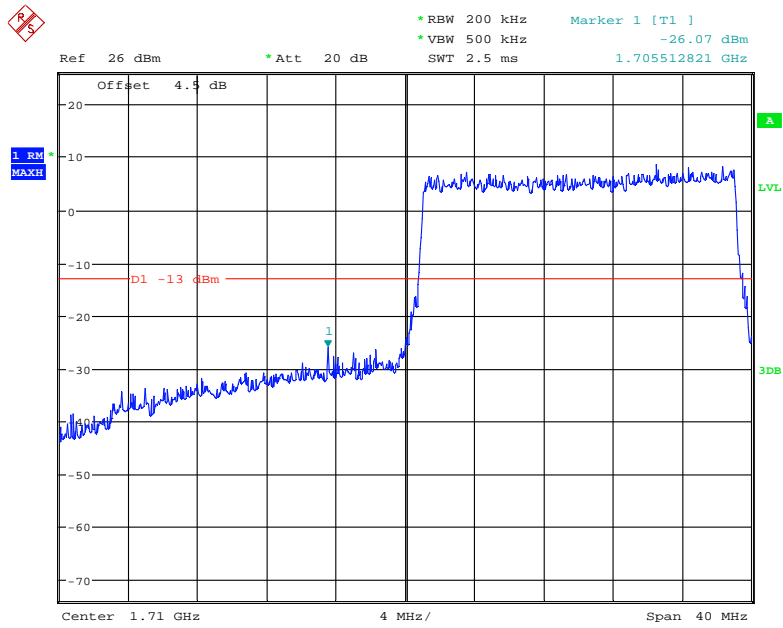

Date: 18.APR.2018 10:00:09

16-QAM (20.0 MHz, FULL RB) - Right Band Edge

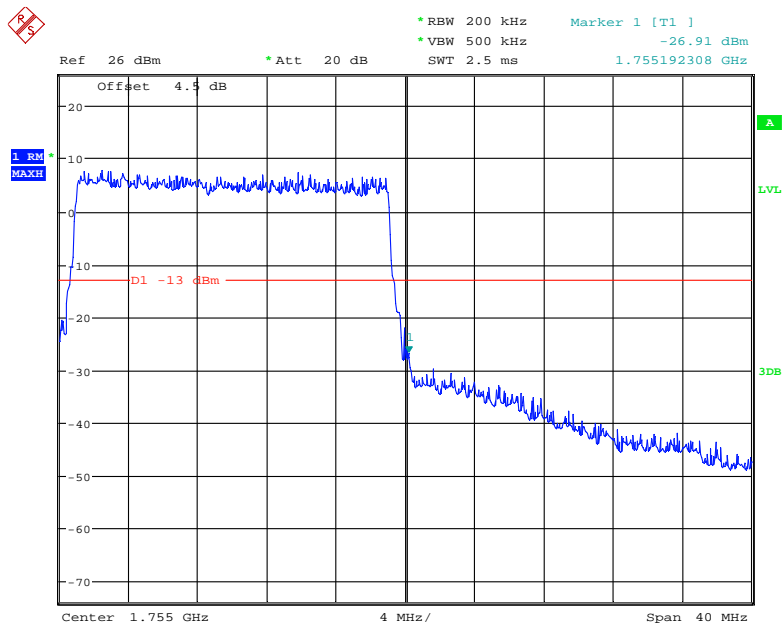

Date: 18.APR.2018 10:00:59

LTE Band 5:

QPSK (1.4 MHz, FULL RB) - Left Band Edge

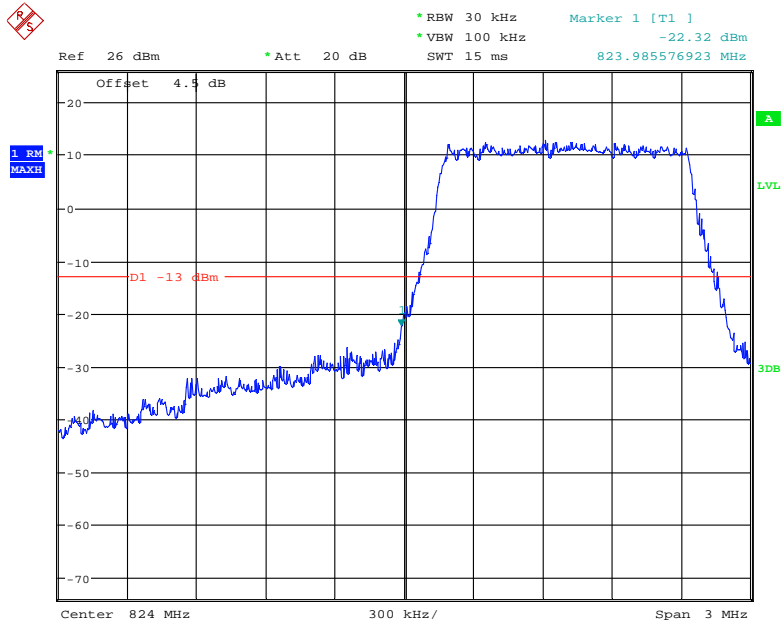

Date: 18.APR.2018 10:03:05

QPSK (1.4 MHz, FULL RB) - Right Band Edge

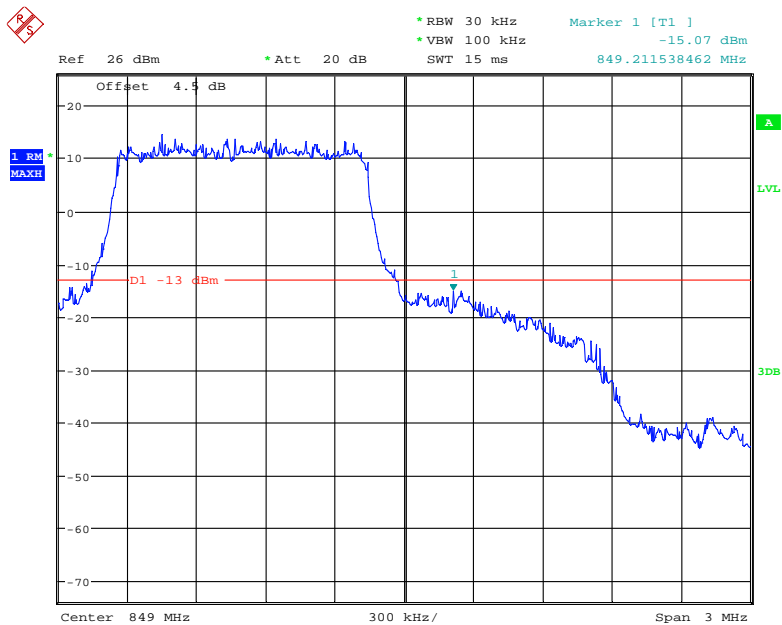

Date: 18.APR.2018 10:05:44

16-QAM (1.4 MHz, FULL RB) - Left Band Edge

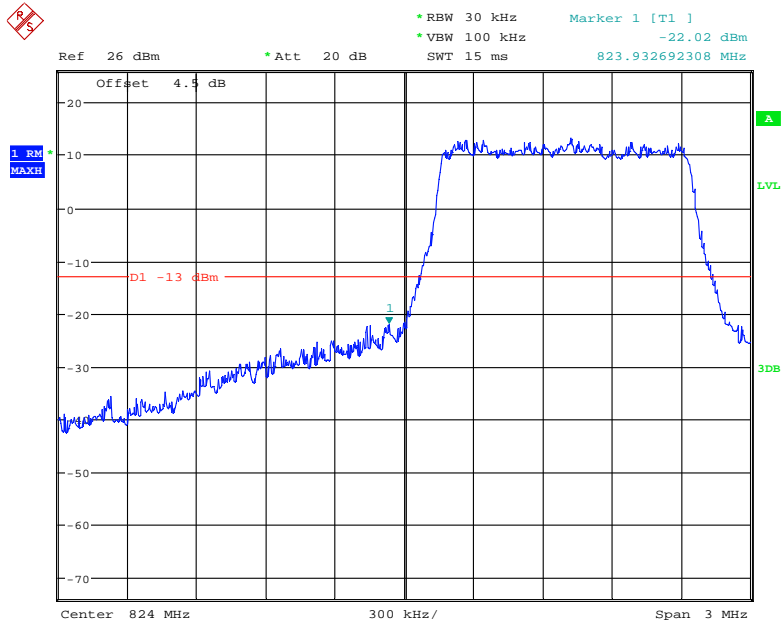

Date: 18.APR.2018 10:03:57

16-QAM (1.4 MHz, FULL RB) - Right Band Edge

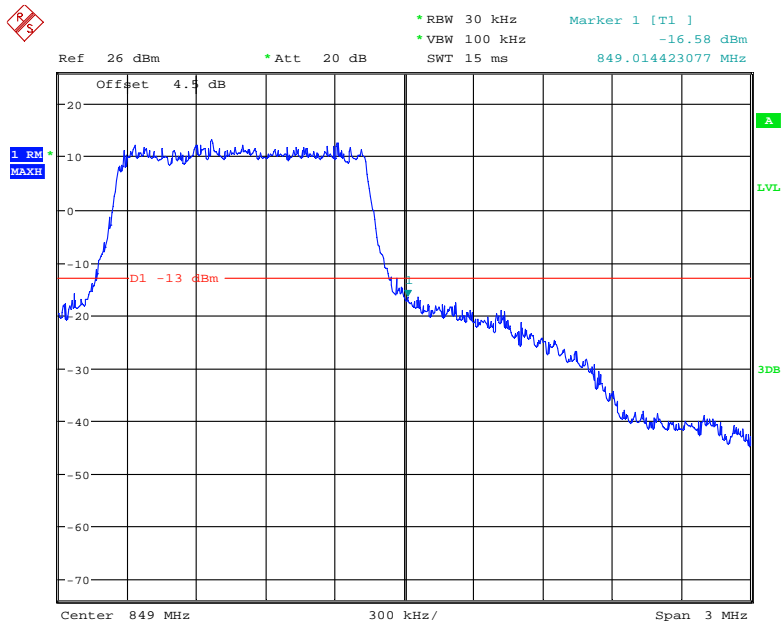

Date: 18.APR.2018 10:05:05

QPSK (3.0 MHz, FULL RB) - Left Band Edge

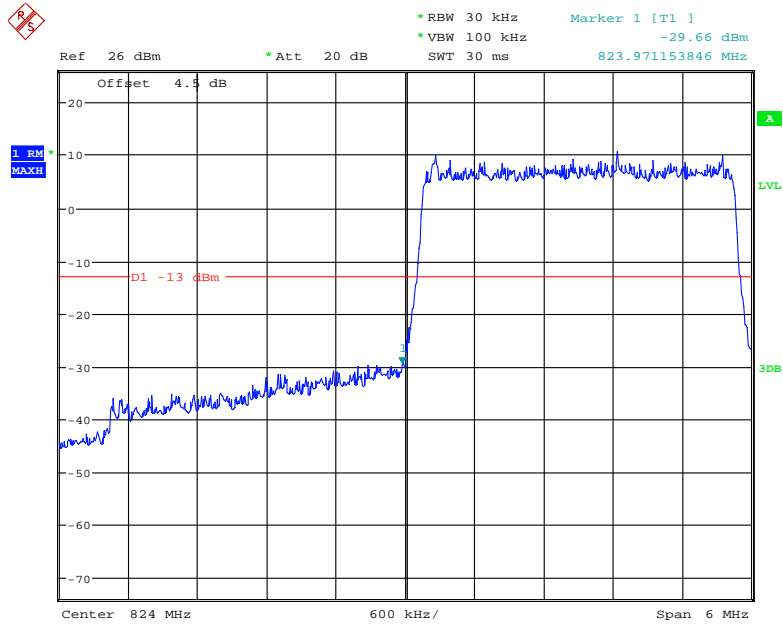

Date: 18.APR.2018 10:07:39

QPSK (3.0 MHz, FULL RB) - Right Band Edge

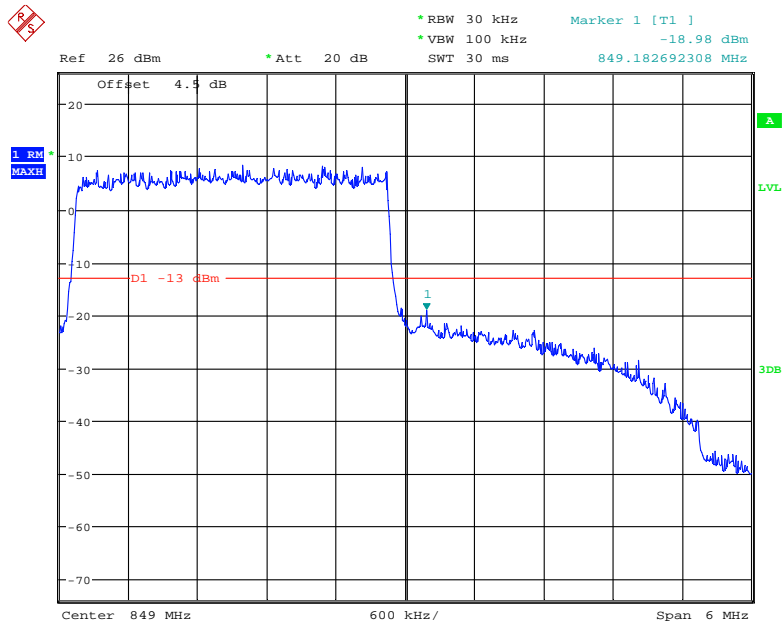

Date: 18.APR.2018 10:09:54

16-QAM (3.0 MHz, FULL RB) - Left Band Edge

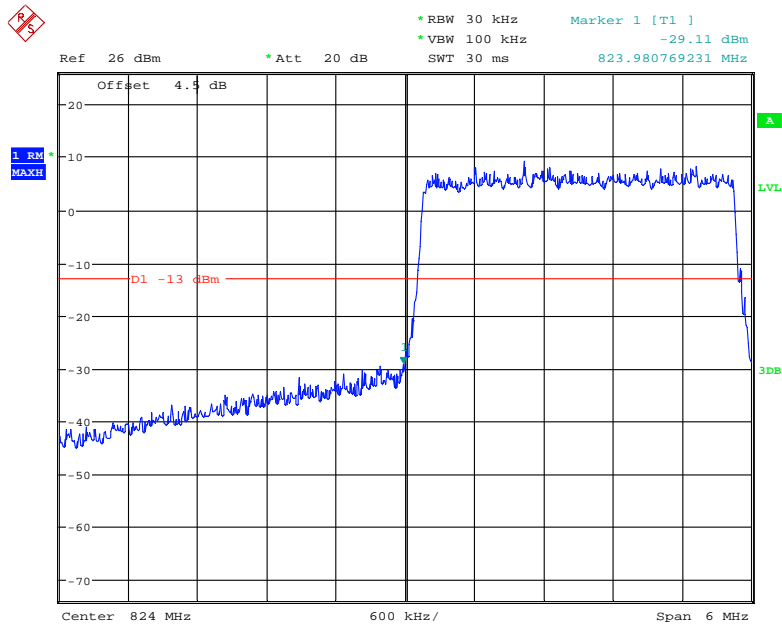

Date: 18.APR.2018 10:08:21

16-QAM (3.0 MHz, FULL RB) - Right Band Edge

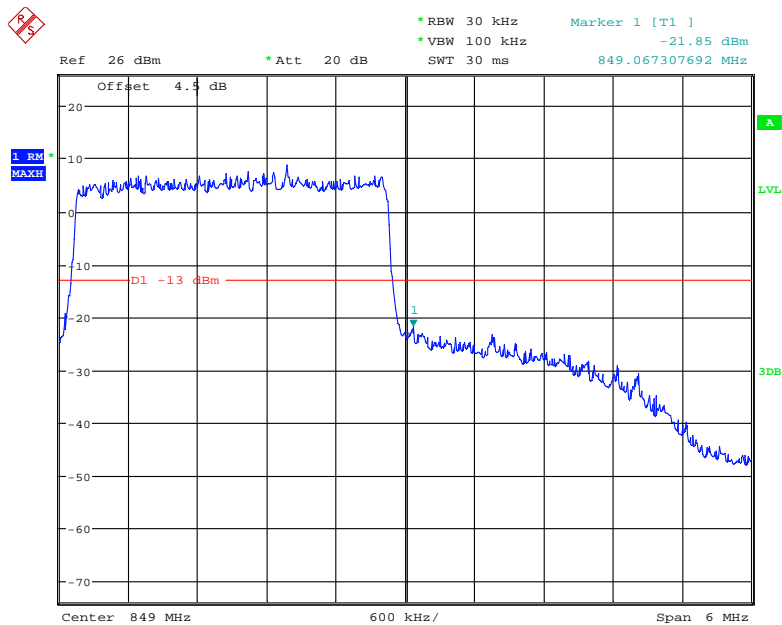

Date: 18.APR.2018 10:09:31

QPSK (5.0 MHz, FULL RB) - Left Band Edge

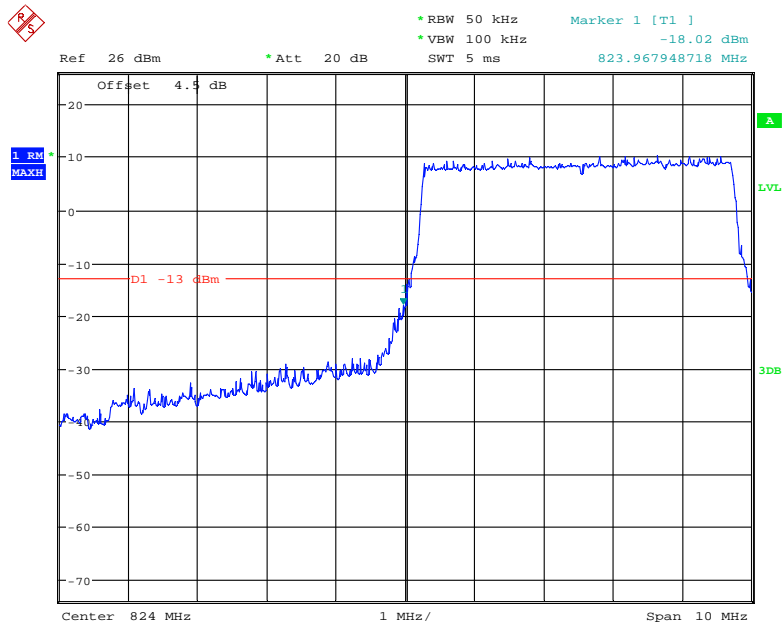

Date: 18.APR.2018 10:57:33

QPSK (5.0 MHz, FULL RB) - Right Band Edge

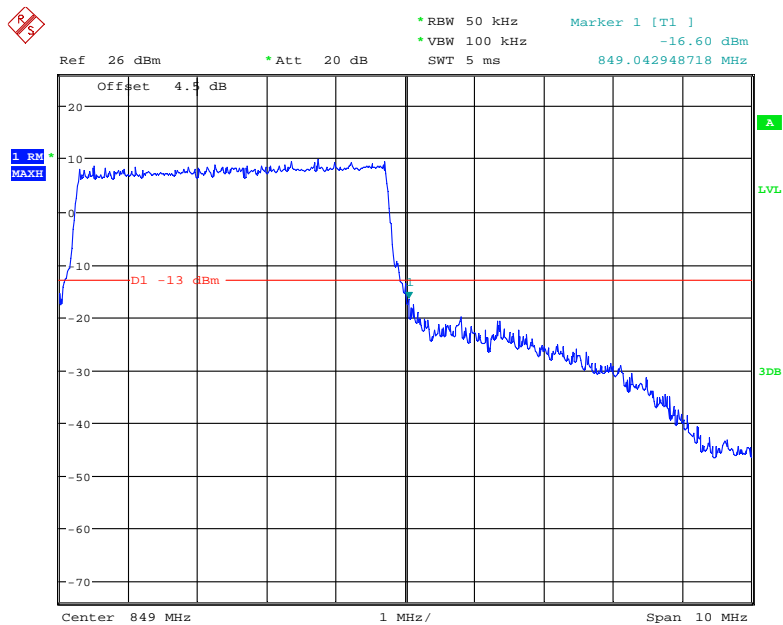

Date: 18.APR.2018 11:00:55

16-QAM (5.0 MHz, FULL RB) - Left Band Edge

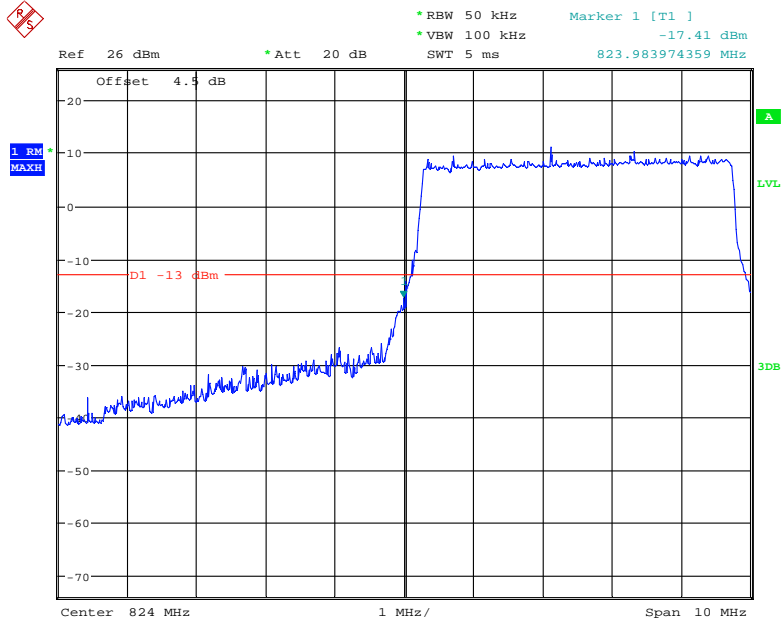

Date: 18.APR.2018 10:58:09

16-QAM (5.0 MHz, FULL RB) - Right Band Edge

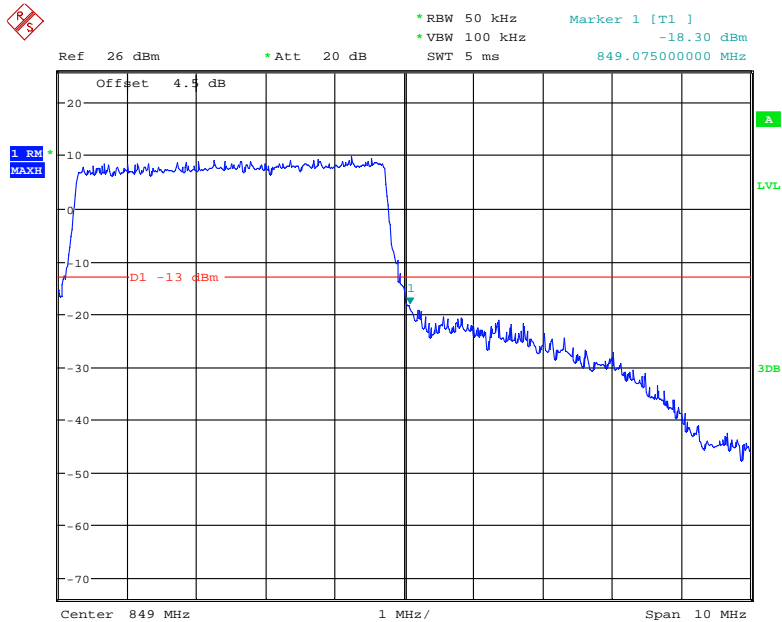

Date: 18.APR.2018 10:59:34

QPSK (10.0 MHz, FULL RB) - Left Band Edge

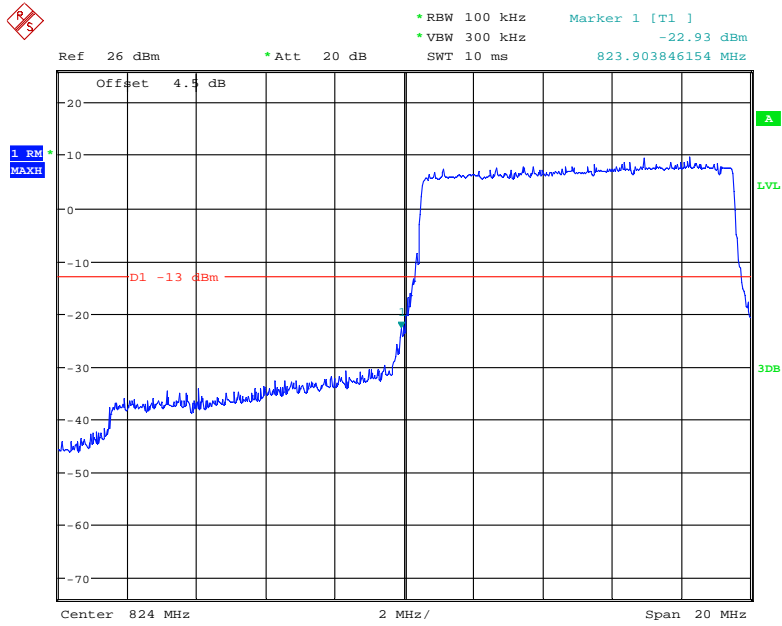

Date: 18.APR.2018 10:19:01

QPSK (10.0 MHz, FULL RB) - Right Band Edge

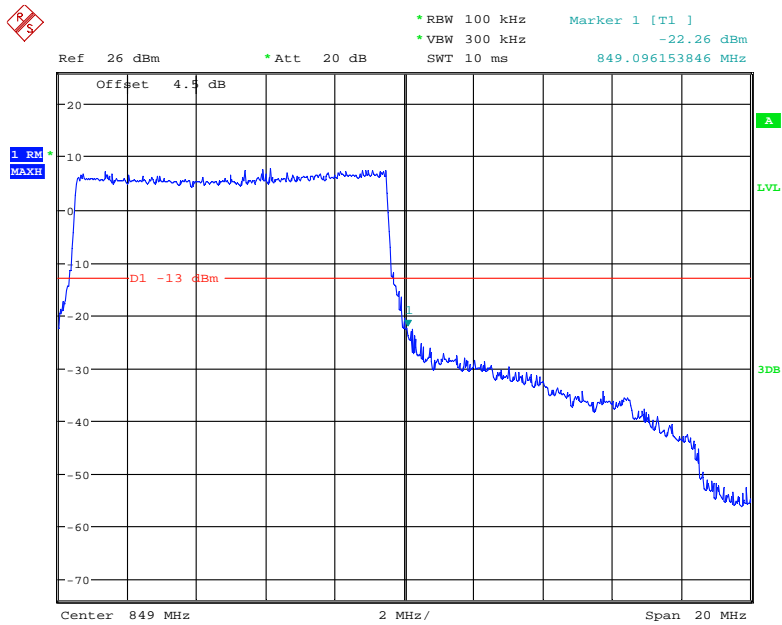

Date: 18.APR.2018 10:20:01

16-QAM (10.0 MHz, FULL RB) - Left Band Edge

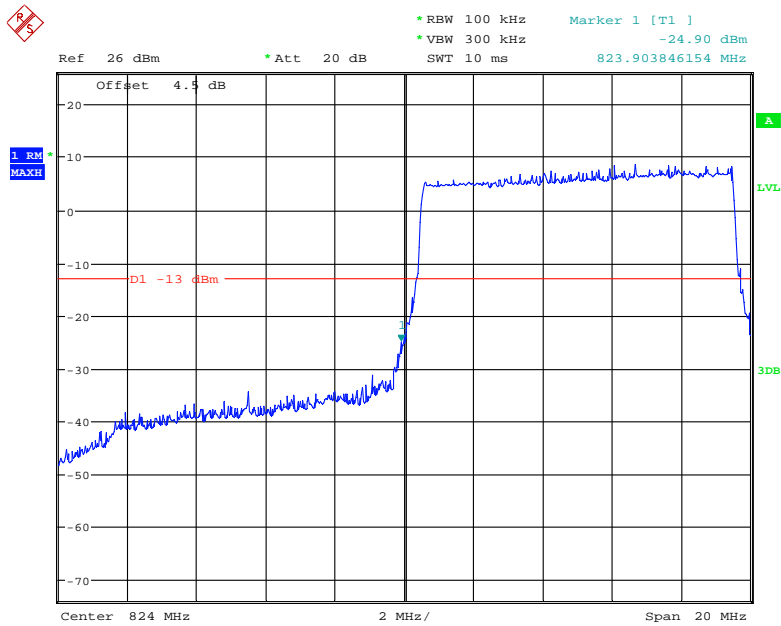

Date: 18.APR.2018 10:18:18

16-QAM (10.0 MHz, FULL RB) - Right Band Edge

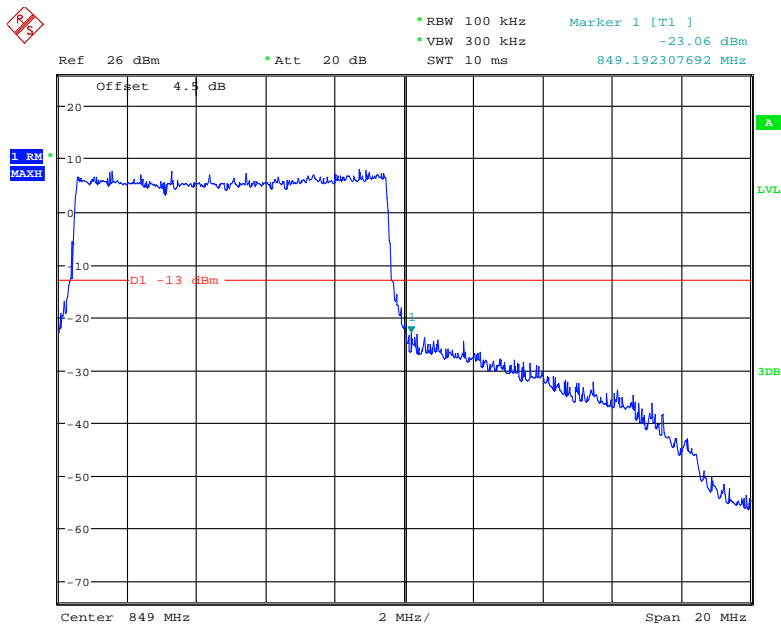

Date: 18.APR.2018 10:20:35

LTE Band 7:

QPSK (5.0 MHz, FULL RB) - Left Band Edge

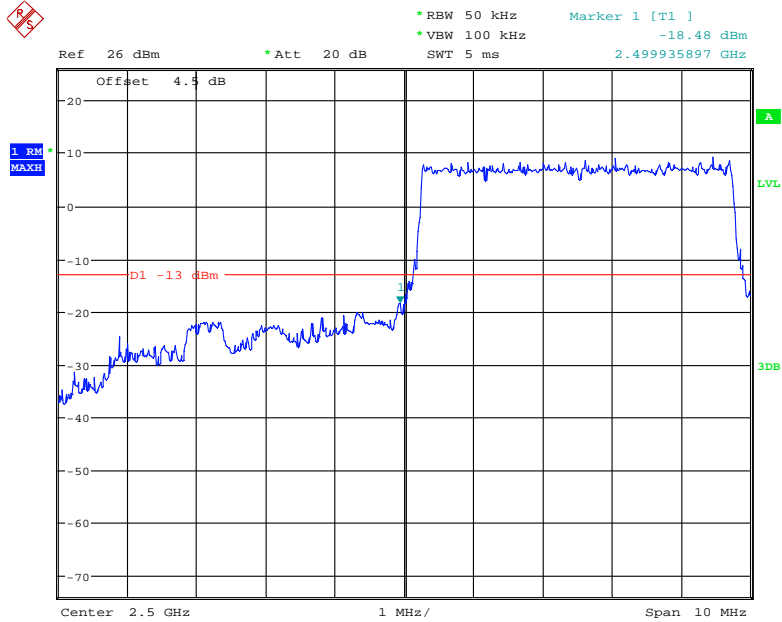

Date: 18.APR.2018 10:23:25

QPSK (5.0 MHz, FULL RB) - Right Band Edge

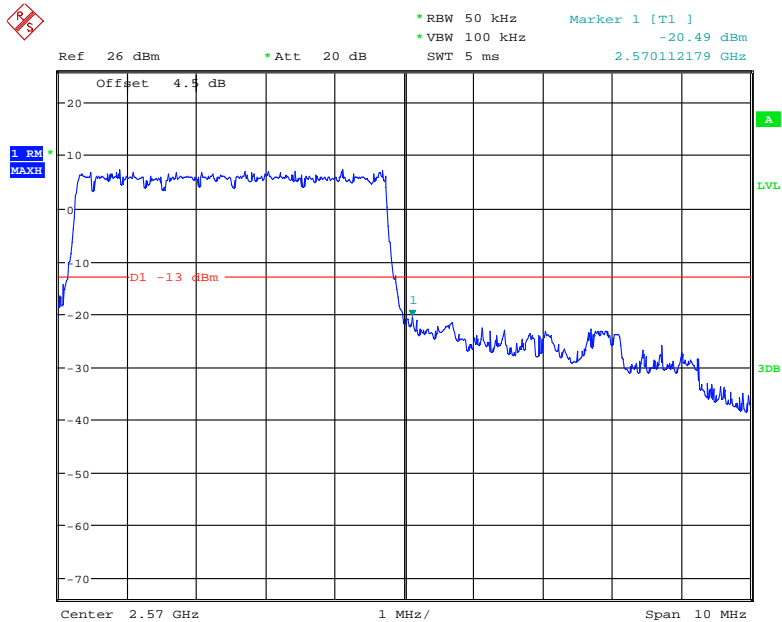

Date: 18.APR.2018 10:25:33

16-QAM (5.0 MHz, FULL RB) - Left Band Edge

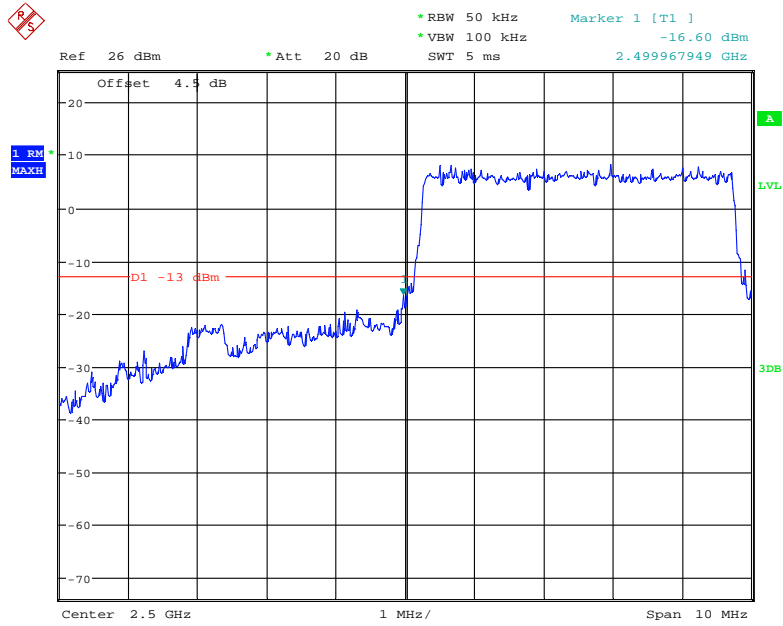

Date: 18.APR.2018 10:24:04

16-QAM (5.0 MHz, FULL RB) - Right Band Edge

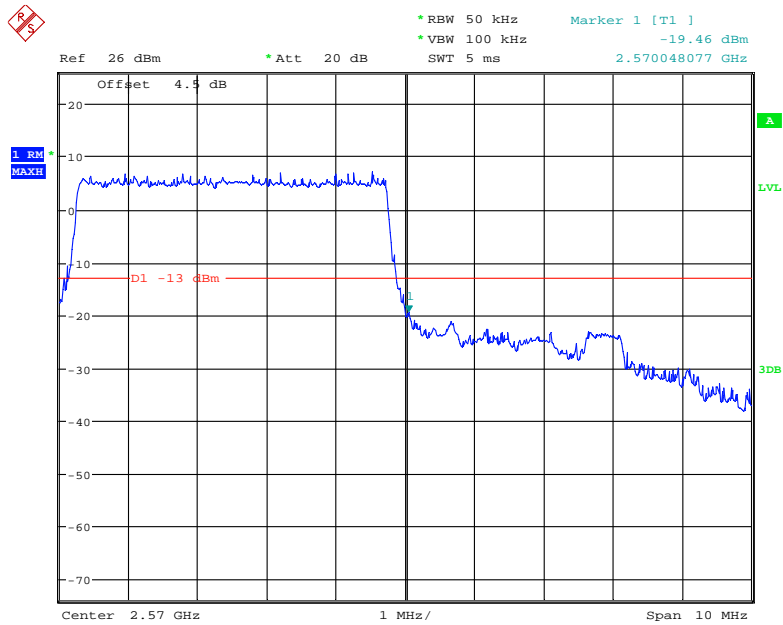

Date: 18.APR.2018 10:25:03

QPSK (10.0 MHz, FULL RB) - Left Band Edge

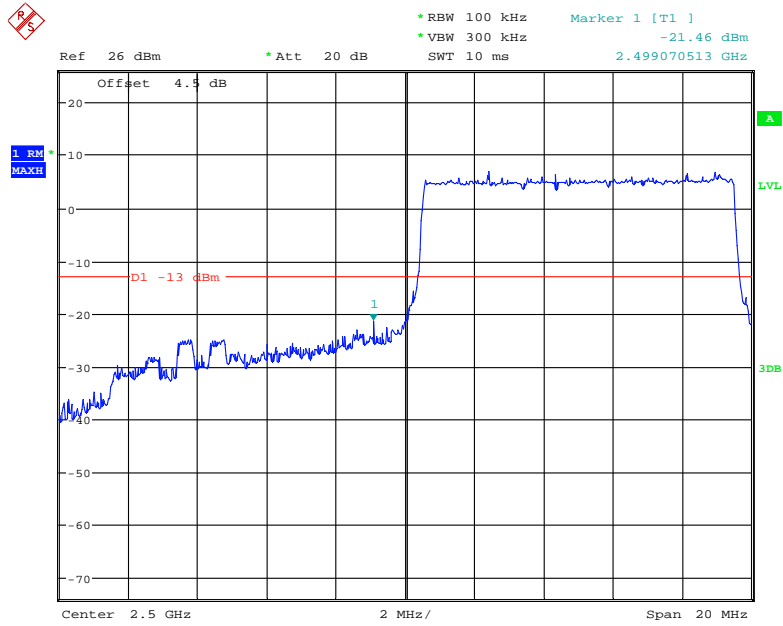

Date: 18.APR.2018 10:32:08

QPSK (10.0 MHz, FULL RB) - Right Band Edge

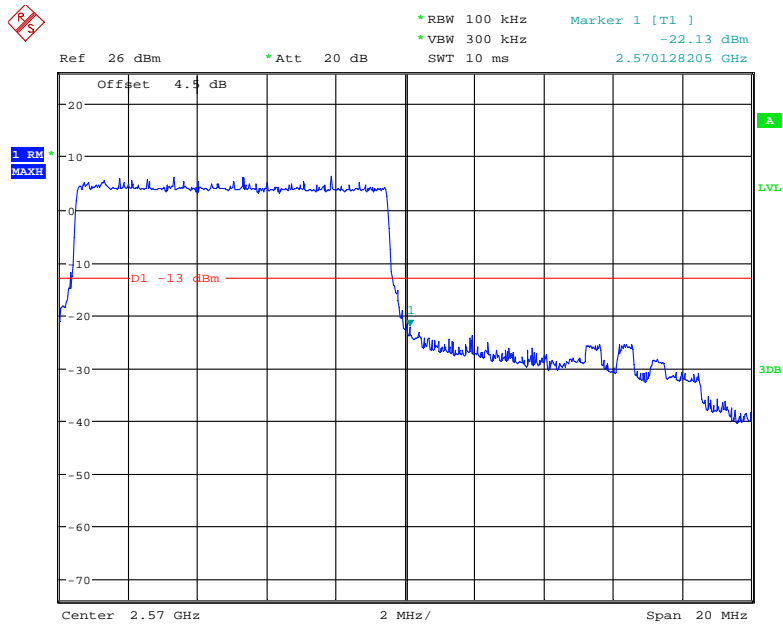

Date: 18.APR.2018 10:33:28

16-QAM (10.0 MHz, FULL RB) - Left Band Edge

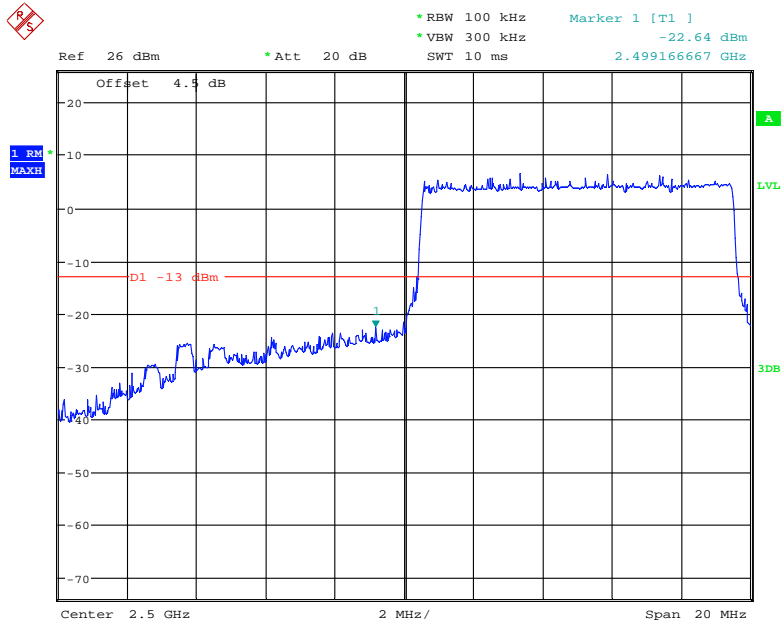

Date: 18.APR.2018 10:31:41

16-QAM (10.0 MHz, FULL RB) - Right Band Edge



Date: 18.APR.2018 10:33:57

QPSK (15 MHz, FULL RB) - Left Band Edge

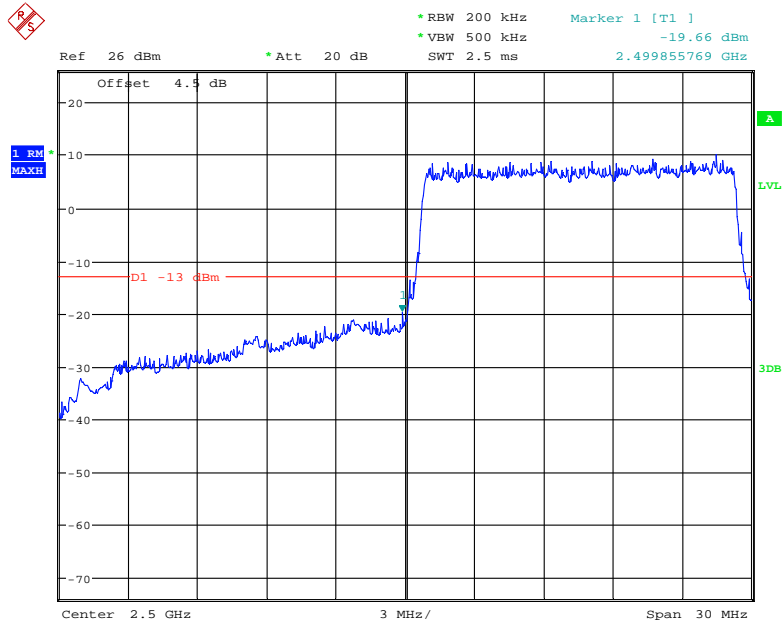

Date: 18.APR.2018 10:35:40

QPSK (15 MHz, FULL RB) - Right Band Edge

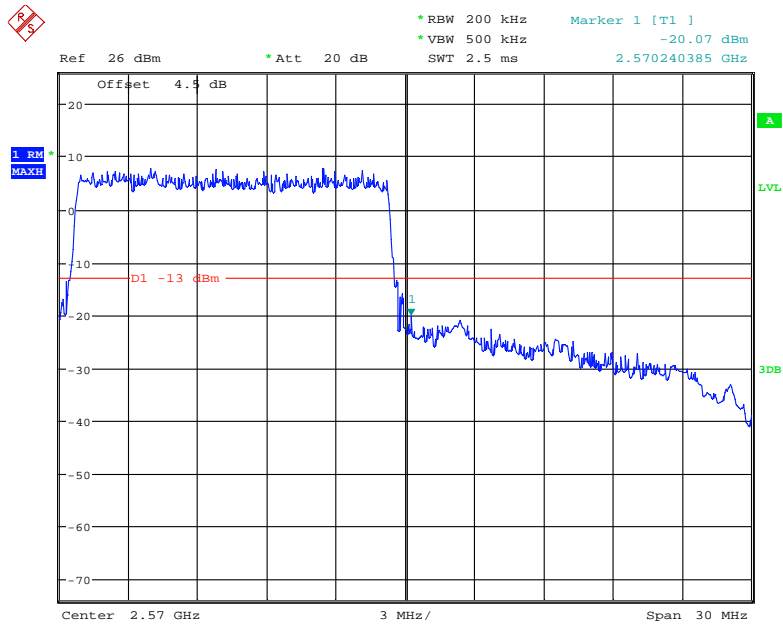

Date: 18.APR.2018 10:37:45

16-QAM (15 MHz, FULL RB) - Left Band Edge

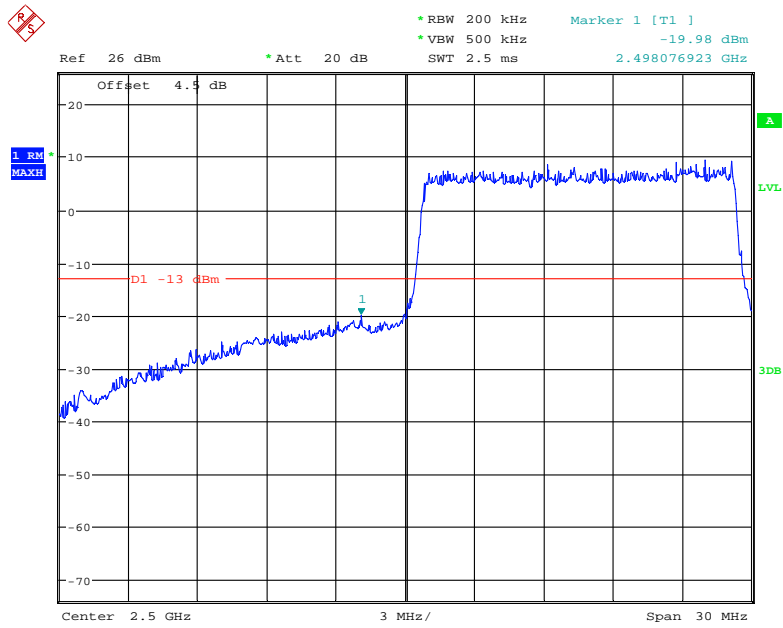

Date: 18.APR.2018 10:36:34

16-QAM (15 MHz, FULL RB) - Right Band Edge

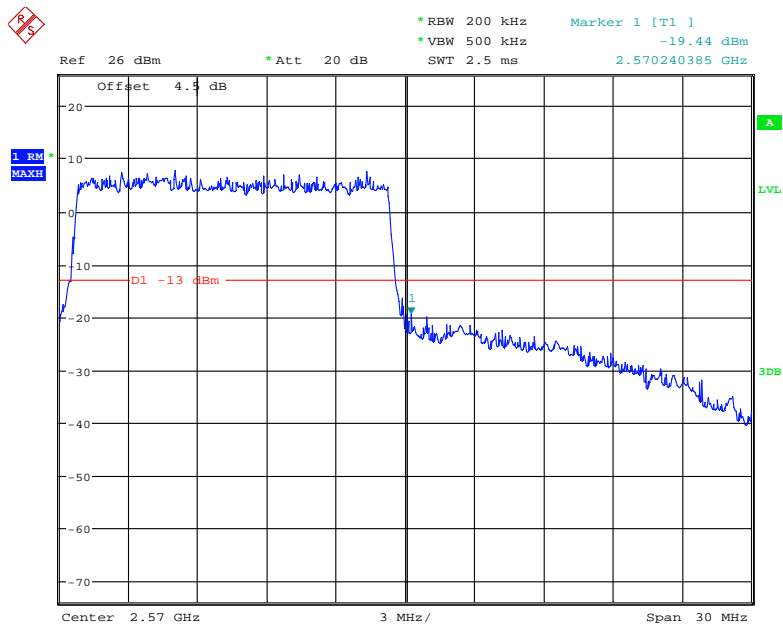

Date: 18.APR.2018 10:37:20

QPSK (20 MHz, FULL RB) - Left Band Edge

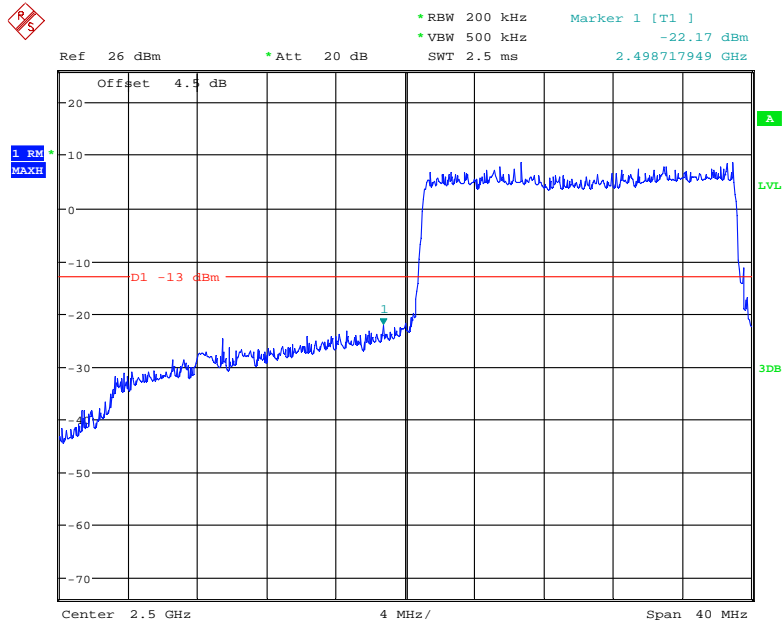

Date: 18.APR.2018 10:39:36

QPSK (20 MHz, FULL RB) - Right Band Edge

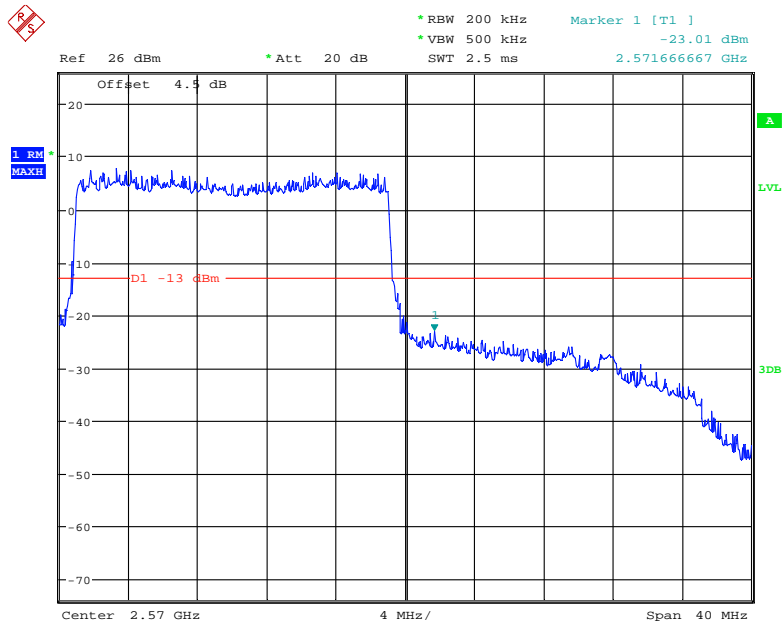

Date: 18.APR.2018 10:41:35

16-QAM (20 MHz, FULL RB) - Left Band Edge

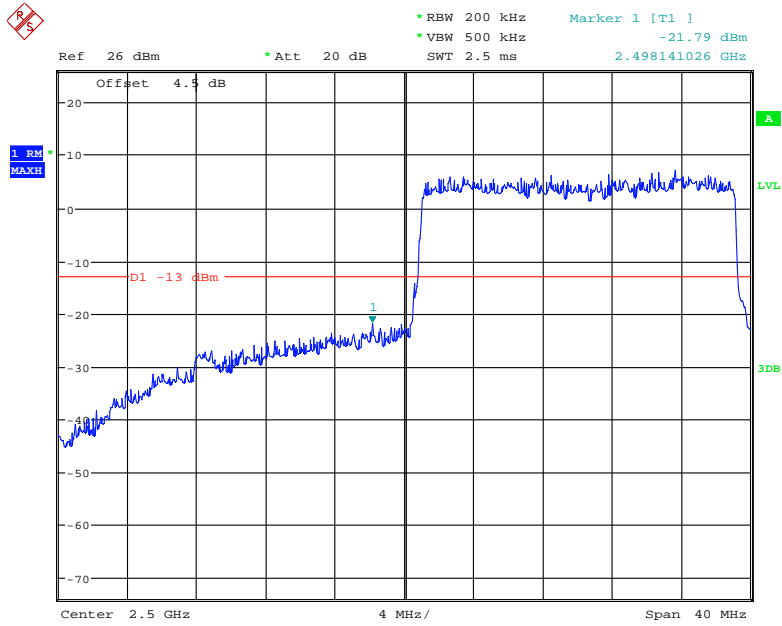

Date: 18.APR.2018 10:40:02

16-QAM (20 MHz, FULL RB) - Right Band Edge

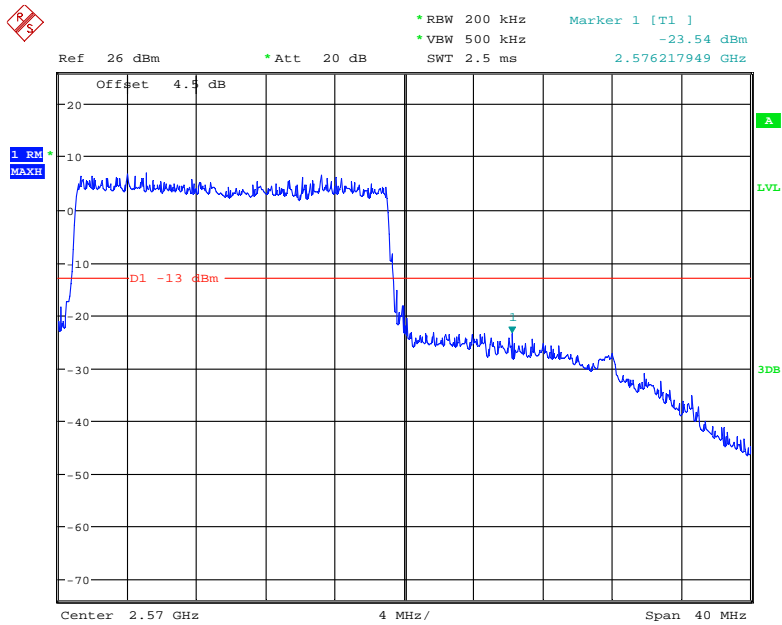

Date: 18.APR.2018 10:40:55

FCC § 2.1055; § 22.355; § 24.235; §27.54 - FREQUENCY STABILITY

Applicable Standard

FCC § 2.1055, §22.355, §24.235 and & §27.54.

According to FCC §2.1055, the frequency stability shall be sufficient to ensure that the fundamental emissions stay within the authorized bands of operation.

According to §22.355, the carrier frequency of each transmitter in the Public Mobile Services must be maintained within the tolerances given in Table below:

Frequency Tolerance for Transmitters in the Public Mobile Services

Frequency Range (MHz)	Base, fixed (ppm)	Mobile ≤ 3 watts (ppm)	Mobile > 3 watts (ppm)
25 to 50	20.0	20.0	50.0
50 to 450	5.0	5.0	50.0
450 to 512	2.5	5.0	5.0
821 to 896	1.5	2.5	2.5
928 to 929.	5.0	N/A	N/A
929 to 960.	1.5	N/A	N/A
2110 to 2220	10.0	N/A	N/A

According to §24.235, the frequency stability shall be sufficient to ensure that the fundamental emissions stays within the authorized frequency block.

Test Procedure

Frequency Stability vs. Temperature: The equipment under test was connected to an external DC power supply and the RF output was connected to communication test set via feed-through attenuators. The EUT was placed inside the temperature chamber. The DC leads and RF output cable exited the chamber through an opening made for the purpose.

After the temperature stabilized for approximately 20 minutes, the frequency output was recorded from the communication test set.

Frequency Stability vs. Voltage: For hand carried, battery powered equipment; reduce primary supply voltage to the battery operating end point which shall be specified by the manufacturer.

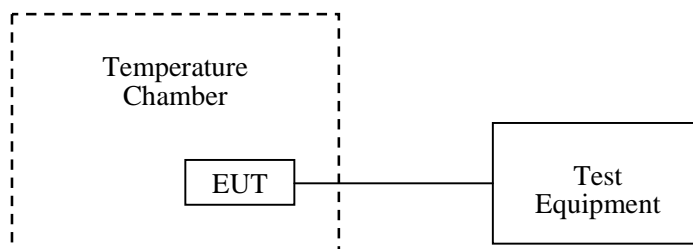

Test Data

Environmental Conditions

Temperature:	25 °C
Relative Humidity:	52 %
ATM Pressure:	101.0 kPa

The testing was performed by Tracy Hu on 2018-04-14.

EUT operation mode: Transmitting

Test Result: Compliance. Please refer to the following tables.

Cellular Band (Part 22H)

GSM Mode

Middle Channel, $f_0=836.6\text{MHz}$				
Temperature (°C)	Voltage Supplied (V _{DC})	Frequency Error (Hz)	Frequency Error (ppm)	Limit (ppm)
-30	3.7	2	0.002391	2.5
-20		-1	-0.001195	2.5
-10		10	0.011953	2.5
0		-2	-0.002391	2.5
10		-3	-0.003586	2.5
20		8	0.009563	2.5
30		13	0.015539	2.5
40		2	0.002391	2.5
50		-2	-0.002391	2.5
25		V min.= 3.5	1	0.001195
	V max.= 4.2	2	0.002391	2.5

EDGE Mode

Middle Channel, $f_0=836.6\text{MHz}$				
Temperature (°C)	Voltage Supplied (V _{DC})	Frequency Error (Hz)	Frequency Error (ppm)	Limit (ppm)
-30	3.7	5	0.005977	2.5
-20		3	0.003586	2.5
-10		4	0.004781	2.5
0		-3	-0.003586	2.5
10		9	0.010758	2.5
20		13	0.015539	2.5
30		2	0.002391	2.5
40		4	0.004781	2.5
50		8	0.009563	2.5
25		V min.= 3.5	8	0.009563
	V max.= 4.2	6	0.007172	2.5

WCDMA Mode

Middle Channel, $f_0=836.6\text{MHz}$				
Temperature (°C)	Voltage Supplied (V _{DC})	Frequency Error (Hz)	Frequency Error (ppm)	Limit (ppm)
-30	3.7	9	0.010758	2.5
-20		8	0.009563	2.5
-10		-9	-0.010758	2.5
0		9	0.010758	2.5
10		7	0.008367	2.5
20		-13	-0.015539	2.5
30		2	0.002391	2.5
40		4	0.004781	2.5
50		6	0.007172	2.5
25	V min.= 3.5	8	0.009563	2.5
	V max.= 4.2	6	0.007172	2.5

PCS Band (Part 24E)

GSM Mode

Middle Channel, $f_0=1880.0\text{ MHz}$				
Temperature (°C)	Voltage Supplied (V _{DC})	Frequency Error (Hz)	Frequency Error (ppm)	Result
-30	3.7	7	0.003723	pass
-20		4	0.002128	pass
-10		11	0.005851	pass
0		-4	-0.002128	pass
10		12	0.006383	pass
20		-7	-0.003723	pass
30		9	0.004787	pass
40		5	0.002660	pass
50		3	0.001596	pass
25	V min.= 3.5	8	0.004255	pass
	V max.= 4.2	-3	-0.001596	pass

EDGE Mode

Middle Channel, $f_o = 1880.0$ MHz				
Temperature (°C)	Voltage Supplied (V _{DC})	Frequency Error (Hz)	Frequency Error (ppm)	Limit (ppm)
-30	3.7	5	0.005977	pass
-20		3	0.003586	pass
-10		4	0.004781	pass
0		-3	-0.003586	pass
10		9	0.010758	pass
20		13	0.015539	pass
30		2	0.002391	pass
40		4	0.004781	pass
50		8	0.009563	pass
25		V min.= 3.5	8	0.009563
	V max.= 4.2	6	0.007172	pass

WCDMA Mode

Middle Channel, $f_o = 1880.0$ MHz				
Temperature (°C)	Voltage Supplied (V _{DC})	Frequency Error (Hz)	Frequency Error (ppm)	Result
-30	3.7	3	0.001596	pass
-20		7	0.003723	pass
-10		6	0.003191	pass
0		5	0.002660	pass
10		-4	-0.002128	pass
20		-17	-0.009043	pass
30		-9	-0.004787	pass
40		8	0.004255	pass
50		-7	-0.003723	pass
25		V min.= 3.5	7	0.003723
	V max.= 4.2	5	0.002660	pass

**LTE:
QPSK:**

Band 2:

10.0 MHz Middle Channel, $f_0 = 1880\text{MHz}$				
Temperature (°C)	Voltage Supplied (V _{DC})	Frequency Error (Hz)	Frequency Error (ppm)	Result
-30	3.7	-2	-0.001064	pass
-20		3	0.001596	pass
-10		1	0.000532	pass
0		13	0.006915	pass
10		7	0.003723	pass
20		-3	-0.001596	pass
30		-1	-0.000532	pass
40		4	0.002128	pass
50		4	0.002128	pass
20		V min.= 3.5	7	0.003723
	V max.= 4.2	-4	-0.002128	pass

Band 4:

10.0 MHz Middle Channel, $f_0 = 1732.5\text{ MHz}$				
Temperature (°C)	Voltage Supplied (V _{DC})	Frequency Error (Hz)	Frequency Error (ppm)	Result
-30	3.7	1	0.00058	pass
-20		9	0.00519	pass
-10		-6	-0.00346	pass
0		2	0.00115	pass
10		-7	-0.00404	pass
20		1	0.00058	pass
30		-5	-0.00289	pass
40		4	0.00231	pass
50		-5	-0.00289	pass
20		V min.= 3.5	5	0.00289
	V max.= 4.2	-7	-0.00404	pass

LTE Band 5:

10.0 MHz Middle Channel, $f_0 = 836.5$ MHz				
Temperature (°C)	Voltage Supplied (V _{DC})	Frequency Error (Hz)	Frequency Error (ppm)	Limit (ppm)
-30	3.7	2	0.002391	2.5
-20		11	0.013150	2.5
-10		1	0.001195	2.5
0		6	0.007173	2.5
10		1	0.001195	2.5
20		3	0.003586	2.5
30		11	0.013150	2.5
40		5	0.005977	2.5
50		3	0.003586	2.5
20	V min.= 3.5	6	0.007173	2.5
	V max.= 4.2	2	0.002391	2.5

LTE Band 7:

10.0 MHz Middle Channel, $f_0 = 2535$ MHz				
Temperature (°C)	Voltage Supplied (V _{DC})	Frequency Error (Hz)	Frequency Error (ppm)	Result
-30	3.7	5	0.00197	pass
-20		1	0.00039	pass
-10		12	0.00473	pass
0		1	0.00039	pass
10		3	0.00118	pass
20		9	0.00355	pass
30		-3	-0.00118	pass
40		12	0.00473	pass
50		3	0.00118	pass
20	V min.= 3.5	4	0.00158	pass
	V max.= 4.2	2	0.00079	pass

16QAM:

Band 2:

10.0 MHz Middle Channel, $f_0 = 1880\text{MHz}$				
Temperature (°C)	Voltage Supplied (V _{DC})	Frequency Error (Hz)	Frequency Error (ppm)	Result
-30	3.7	5	0.002660	pass
-20		4	0.002128	pass
-10		4	0.002128	pass
0		2	0.001064	pass
10		-5	-0.002660	pass
20		5	0.002660	pass
30		1	0.000532	pass
40		13	0.006915	pass
50		-1	-0.000532	pass
20		V min.= 3.5	-3	-0.001596
	V max.= 4.2	8	0.004255	pass

Band 4:

10.0 MHz Middle Channel, $f_0 = 1732.5\text{ MHz}$				
Temperature (°C)	Voltage Supplied (V _{DC})	Frequency Error (Hz)	Frequency Error (ppm)	Result
-30	3.7	-4	-0.00231	pass
-20		6	0.00346	pass
-10		4	0.00231	pass
0		8	0.00462	pass
10		11	0.00635	pass
20		12	0.00693	pass
30		8	0.00462	pass
40		1	0.00058	pass
50		14	0.00808	pass
20		V min.= 3.5	1	0.00058
	V max.= 4.2	8	0.00462	pass

LTE Band 5:

10.0 MHz Middle Channel, $f_0 = 836.5$ MHz				
Temperature (°C)	Voltage Supplied (V _{DC})	Frequency Error (Hz)	Frequency Error (ppm)	Limit (ppm)
-30	3.7	2	0.002391	2.5
-20		-4	-0.004782	2.5
-10		2	0.002391	2.5
0		4	0.004782	2.5
10		13	0.015541	2.5
20		6	0.007173	2.5
30		10	0.011955	2.5
40		8	0.009564	2.5
50		5	0.005977	2.5
20		V min.= 3.5	8	0.009564
	V max.= 4.2	-4	-0.004782	2.5

LTE Band 7:

10.0 MHz Middle Channel, $f_0 = 2535$ MHz				
Temperature (°C)	Voltage Supplied (V _{DC})	Frequency Error (Hz)	Frequency Error (ppm)	Result
-30	3.7	2	0.00079	pass
-20		4	0.00158	pass
-10		1	0.00039	pass
0		10	0.00394	pass
10		11	0.00434	pass
20		3	0.00118	pass
30		-2	-0.00079	pass
40		8	0.00316	pass
50		-4	-0.00158	pass
20		V min.= 3.5	7	0.00276
	V max.= 4.2	-2	-0.00079	pass

******* END OF REPORT *******