



FCC TEST REPORT

FCC ID: 2A06H-CKWL1021

Product Name:	wireless charging pad
Trademark:	Innotech
Model Number:	CKWL1021 LDLC QI BASE, CKWL1021-01, CKWL1021-02, CKWL1021-05, CKWL1021-06, CKWL1021-07, CKWL1021-08, CKWL1021-09, CKWL1021-10
Prepared For :	BeiHai Innotech Technology Co., Ltd
Address :	Building No. A02, CECT Industrial Park, BeiHai Industrial Zone, BeiHai, Guangxi, P. R. China
Prepared By :	Shenzhen BCTC Testing Co., Ltd.
Address :	BCTC Building & 1-2F, East of B Building, Pengzhou Industrial, Fuyuan 1st Road, Qiaotou Community, Fuyong Street, Bao'an District, Shenzhen, China
Test Date:	Apr. 20 – Apr. 27, 2018
Date of Report :	Apr. 27, 2018
Report No.:	BCTC-LH180300662E



TABLE OF CONTENTS

TEST REPORT DECLARATION	3
1.GENERAL INFORMATION	4
1.1. Report information.....	4
1.2. Measurement Uncertainty	4
1.3. Test Facility.....	4
1.4. Test Uncertainty.....	4
2.PRODUCT DESCRIPTION	5
2.1. EUT Description.....	5
2.2. Test mode.....	5
2.3. Block Diagram of EUT Configuration.....	5
2.4. Test Conditions.....	6
2.5. Description Of Support Units (Conducted Mode)	6
3.TEST RESULTS SUMMARY	6
4.TEST EQUIPMENT USED.....	7
4.1. For Conducted Emission Test	7
4.2. For Radiated Emission Measurement.....	7
5.CONDUCTED EMISSION TEST.....	8
5.1. Block Diagram of Test Setup	8
5.2. Test Standard.....	8
5.3. Conducted Emission Limit.....	8
5.4. EUT Configuration on Test.....	8
5.5. Operating Condition of EUT.....	9
5.6. Test Procedure.....	9
5.7. Test Result.....	9
6.RADIATED EMISSION MEASUREMENT	14
6.1. Block Diagram of Test Setup	14
6.2. Test Standard and Limit	15
6.3. EMI Test Receiver Setup	15
6.4. Test Procedure.....	16
6.5. Test Result.....	16
7. EUT TEST PHOTOS.....	22
8. EUT PHOTOS	24



TEST REPORT DECLARATION

Applicant : BeiHai Innotech Technology Co., Ltd
Address : Building No. A02, CECT Industrial Park, BeiHai Industrial Zone, BeiHai, Guangxi, P. R. China
EUT Description : wireless charging pad
Model Number CKWL1021
LDLC QI BASE, CKWL1021-01, CKWL1021-02, CKWL1021-05, CKWL1021-06, CKWL1021-07, CKWL1021-08, CKWL1021-09, CKWL1021-10

Test Standards:

FCC Part 15 C

This device described above has been tested by BCTC, and the test results show that the equipment under And it is applicable only to the tested sample identified in the report.

This report shall not be reproduced except in full, without the written approval of BCTC, this document may be altered or revised by BCTC, personal only, and shall be noted in the revision of the document.

Prepared by(Engineer): Eric Yang
Reviewer(Supervisor): Jade Yang
Approved(Manager): Carson Zhang

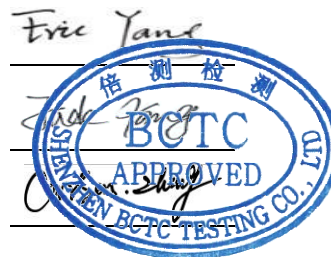



1. GENERAL INFORMATION

1.1. Report information

- 1.1.1. This report is not a certificate of quality; it only applies to the sample of the specific product/equipment given at the time of its testing. The results are not used to indicate or imply that they are application to the similar items. In addition, such results must not be used to indicate or imply that BCTC approves recommends or endorses the manufacture, supplier or use of such product/equipment, or that BCTC in any way guarantees the later performance of the product/equipment.
- 1.1.2. The sample/s mentioned in this report is/are supplied by Applicant, BCTC therefore assumes no responsibility for the accuracy of information on the brand name, model number, origin of manufacture or any information supplied.
- 1.1.3. Additional copies of the report are available to the Applicant at an additional fee. No third part can obtain a copy of this report through BCTC, unless the applicant has authorized BCTC in writing to do so.

1.2. Measurement Uncertainty

Available upon request.

1.3. Test Facility

Site Description
Name of Firm : Shenzhen BCTC Testing Co., Ltd.

Site Location : BCTC Building & 1-2F, East of B Building,
Pengzhou Industrial, Fuyuan 1st Road, Qiaotou
Community, Fuyong Street, Bao'an District,
Shenzhen, China

1.4. Test Uncertainty

Conducted Emission = ± 2.66 dB
Uncertainty
Radiated Emission Uncertainty = ± 4.15 dB

2. PRODUCT DESCRIPTION

2.1.EUT Description

Description : **wireless charging pad**

Applicant : **BeiHai Innotech Technology Co., Ltd**
 Building No. A02, CECT Industrial Park, BeiHai Industrial Zone,
 BeiHai, Guangxi, P. R. China

Manufacturer : **BeiHai Innotech Technology Co., Ltd**
 Building No. A02, CECT Industrial Park, BeiHai Industrial Zone,
 BeiHai, Guangxi, P. R. China

Trademark : **Innotech**

Model Number : CKWL1021

Serial Model : LDLC QI BASE, CKWL1021-01, CKWL1021-02,
 CKWL1021-05, CKWL1021-06, CKWL1021-07,
 CKWL1021-08, CKWL1021-09, CKWL1021-10

Model Difference : All the model are the same circuit and RF module, except
 model names

Power Supply : Input: 5V/2A 9V/2A
 Output: 5W / 7.5W / 10W Max

Work Frequency : 110-148KHz

Operation Frequency each of channel

Channel List					
Channel	Frequency (kHz)	Channel	Frequency (kHz)	Channel	Frequency (kHz)
00	110	03	125	06	140
01	115	04	130	07	145
02	120	05	135	08	148

2.2.Test mode

Test Modes	keeping TX+Charging mode
------------	--------------------------

2.3.Block Diagram of EUT Configuration

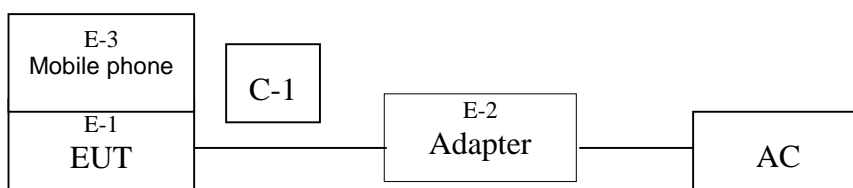



2.4. Test Conditions

Temperature: 23~25°C

Relative Humidity: 55~63 %

2.5. Description Of Support Units (Conducted Mode)

The EUT has been tested as an independent unit together with other necessary accessories or support units. The following support units or accessories were used to form a representative test configuration during the tests.

Item	Equipment	Mfr/Brand	Model/Type No.	Series No.	Note
E-1	wireless charging pad	Innotech	CKWL1021	N/A	EUT
E-2	Adapter	N/A	S018BYU1200150	N/A	AC100-240V50/60Hz 600mA Output: 5V $\overline{\text{---}}$ 3A 9V $\overline{\text{---}}$ 2A
E-3	Mobile phone	N/A	SamSung-S7	N/A	

Item	Shielded Type	Ferrite Core	Length	Note
C-1	NO	NO	1.2M	USB cable unshielded

Note:

- (1) The support equipment was authorized by Declaration of Confirmation.
- (2) For detachable type I/O cable should be specified the length in cm in 『Length』 column.
- (3) “YES” is means “shielded” “with core”; “NO” is means “unshielded” “without core”.

3. TEST RESULTS SUMMARY

Table 1 Test Results Summary

Test Items	Test Results
Conducted disturbance	Pass
Radiated disturbance	Pass

Remark: “N/A” means “Not applicable.”



4. TEST EQUIPMENT USED

4.1. For Conducted Emission Test

Item	Equipment	Manufacturer	Type No.	Serial No.	Last calibration	Calibrated until
1	Test Receiver	R&S	ESCI	1166.5950K03-1 01165-ha	2017.08.27	2018.08.26
2	LISN	SCHWARZBECK	NSLK8127	8127739	2017.08.27	2018.08.26
3	LISN	R&S	NSLK8126	8126487	2017.08.27	2018.08.26
4	RF cables	R&S	R204	R20X	2017.08.27	2018.08.26
5	Attenuator	R&S	ESH3-Z2	143206	2017.08.27	2018.08.26

4.2. For Radiated Emission Measurement

Item	Equipment	Manufacturer	Type No.	Serial No.	Last calibration	Calibrated until
5	Horn Antenna (14GHz-40GHz)	SCHWARZBECK	BBHA 9170	9170-181	2017.09.03	2018.09.02
6	Amplifier (9KHz-6GHz)	SCHWARZBECK	BBV9744	9744-0037	2017.08.27	2018.08.26
7	Amplifier (1GHz-18GHz)	SCHWARZBECK	BBV9718	9718-309	2017.08.27	2018.08.26
8	Amplifier (18GHz-40GHz)	SCHWARZBECK	BBV 9721	9721-205	2017.08.27	2018.08.26
9	Loop Antenna (9KHz-30MHz)	SCHWARZBECK	FMZB1519B	00014	2017.09.03	2018.09.02
10	RF cables1 (9kHz-1GHz)	R&S	R203	R20X	2017.08.27	2018.08.26
11	RF cables2 (1GHz-40GHz)	R&S	R204	R21X	2017.08.27	2018.08.26
12	Antenna connector	Florida RF Labs	N/A	RF 01#	2017.08.27	2018.08.26
13	Power Metter	ANRITSU	ML2487A	6K00001568	2017.08.27	2018.08.26
14	Power Sensor (AV)	ANRITSU	ML2491A	030989	2017.08.27	2018.08.26
15	Signal Analyzer 9kHz-26.5GHz	Agilent	N9010A	MY48030494	2017.08.27	2018.08.26
16	Test Receiver 20kHz-40GHz	R&S	ESU 40	100376	2017.08.27	2018.08.26
17	D.C. Power Supply	LongWei	PS-305D	010964729	2017.08.27	2018.08.26

5. CONDUCTED EMISSION TEST

5.1. Block Diagram of Test Setup

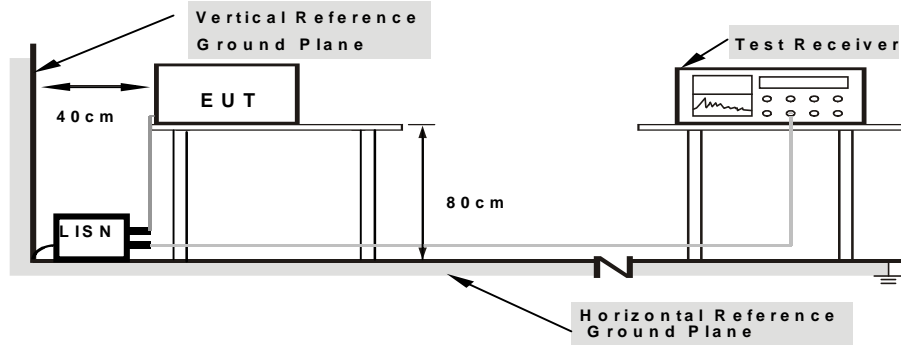

Note: 1.Support units were connected to second LISN.
 2.Both of LISNs (AMN) are 80 cm from EUT and at least 80 cm from other units and other metal planes

The setup of EUT is according with per ANSI C63.10-2013 measurement procedure. The specification used was with the FCC Part 15.207 limits.

(EUT: **wireless charging pad**)

5.2. Test Standard

FCC§15.207

5.3. Conducted Emission Limit

Frequency MHz	Limits dB(μV)	
	Quasi-peak Level	Average Level
0.15 ~ 0.50	66 ~ 56*	56 ~ 46*
0.50 ~ 5.00	56	46
5.00 ~ 30.00	60	50

Notes: 1. *Decreasing linearly with logarithm of frequency.

5.4. EUT Configuration on Test

The following equipments are installed on conducted emission test to meet FCC Part 15.207 requirement and operating in a manner, which tends to maximize its emission characteristics in a normal application.

5.4.1. milestone dual

Model Number: **CKWL1021**



5.5. Operating Condition of EUT

5.5.1. Setup the EUT and simulators as shown in Section 5.1.

5.5.2. Turn on the power of all equipments.

5.5.3. Let the EUT work in test modes (EUT Working) and test it.

5.6. Test Procedure

The EUT is put on a table of non-conducting material that is 80cm high. The vertical conducting wall of shielding is located 40cm to the rear of the EUT. The power line of the EUT is connected to the AC mains through a Artificial Mains Network (A.M.N.). A EMI test receiver (R&S Test Receiver ESHS30) is used to test the emissions form both sides of AC line. The bandwidth of EMI test receiver is set at 9kHz.

The bandwidth of the test receiver (R&S Test Receiver ESHS30) is set at 10KHz.

We pretest AC 120V and AC 240V, the worst voltage was AC 120V and the data recording in the report.

5.7. Test Result

PASS

Please refer to the following pages.



EUT:	wireless charging pad	Model Name :	CKWL1021
Temperature:	26 °C	Relative Humidity:	54%
Pressure:	1010hPa	Phase :	L
Test Voltage :	DC 5V For Adapter (adapter input:AC120V/60Hz)	Test Mode:	Normal Link

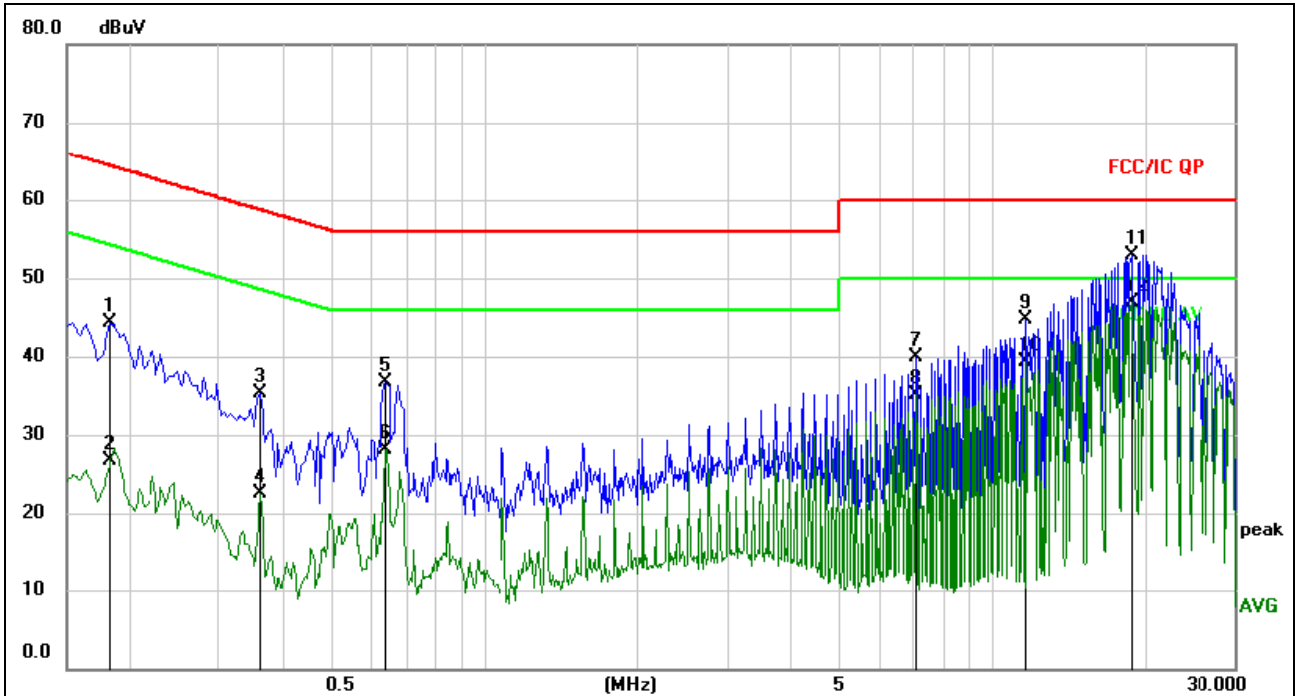

Remark:
 1. All readings are Quasi-Peak and Average values.
 2. Factor = Insertion Loss + Cable Loss.

No.	Mk.	Freq. MHz	Reading Level dBuV	Correct Factor dB	Measure- ment dBuV	Limit dBuV	Over dB	Detector	Comment
1		0.1815	34.71	9.66	44.37	64.42	-20.05	QP	
2		0.1815	16.98	9.66	26.64	54.42	-27.78	AVG	
3		0.3615	25.63	9.67	35.30	58.69	-23.39	QP	
4		0.3615	12.83	9.67	22.50	48.69	-26.19	AVG	
5		0.6360	27.10	9.68	36.78	56.00	-19.22	QP	
6		0.6360	18.51	9.68	28.19	46.00	-17.81	AVG	
7		7.0622	30.20	9.80	40.00	60.00	-20.00	QP	
8		7.0622	25.24	9.80	35.04	50.00	-14.96	AVG	
9		11.5594	34.83	9.82	44.65	60.00	-15.35	QP	
10		11.5594	29.41	9.82	39.23	50.00	-10.77	AVG	
11		18.8025	43.00	9.86	52.86	60.00	-7.14	QP	
12	*	18.8025	37.07	9.86	46.93	50.00	-3.07	AVG	



EUT:	wireless charging pad	Model Name. :	CKWL1021
Temperature:	26 °C	Relative Humidity:	54%
Pressure:	1010hPa	Phase :	N
Test Voltage :	DC 5V For Adapter (adapter input:AC120V/60Hz)	Test Mode:	Normal Link

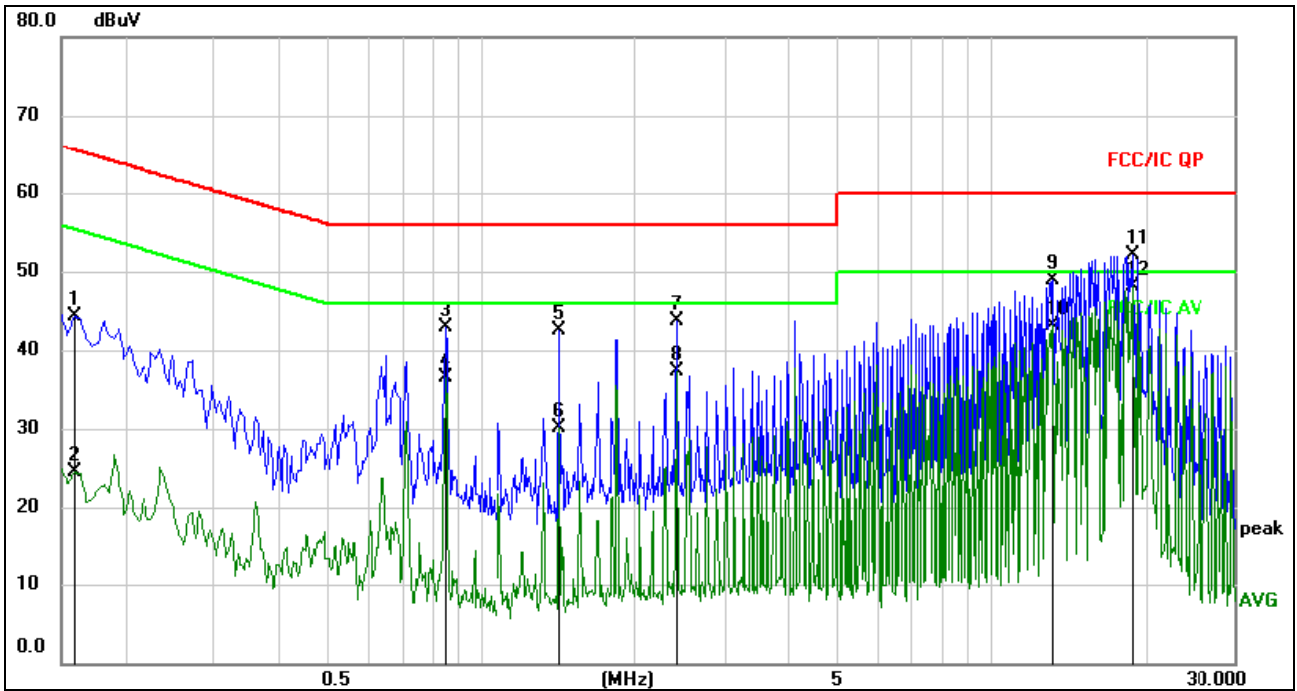

Remark:
 1. All readings are Quasi-Peak and Average values.
 2. Factor = Insertion Loss + Cable Loss.

No.	Mk.	Freq. MHz	Reading Level dBuV	Correct Factor dB	Measure- ment dBuV	Limit dBuV	Over dB	Detector	Comment
1		0.1590	34.67	9.67	44.34	65.52	-21.18	QP	
2		0.1590	14.80	9.67	24.47	55.52	-31.05	AVG	
3		0.8520	33.16	9.69	42.85	56.00	-13.15	QP	
4		0.8520	26.85	9.69	36.54	46.00	-9.46	AVG	
5		1.4181	32.73	9.70	42.43	56.00	-13.57	QP	
6		1.4181	20.44	9.70	30.14	46.00	-15.86	AVG	
7		2.4089	33.92	9.72	43.64	56.00	-12.36	QP	
8		2.4089	27.63	9.72	37.35	46.00	-8.65	AVG	
9		13.2585	39.11	9.84	48.95	60.00	-11.05	QP	
10		13.2585	33.23	9.84	43.07	50.00	-6.93	AVG	
11		18.8385	42.23	9.86	52.09	60.00	-7.91	QP	
12	*	18.8385	38.33	9.86	48.19	50.00	-1.81	AVG	



EUT:	wireless charging pad	Model Name :	CKWL1021
Temperature:	26 °C	Relative Humidity:	54%
Pressure:	1010hPa	Phase :	L
Test Voltage :	DC 9V For Adapter (adapter input:AC120V/60Hz)	Test Mode:	Charging

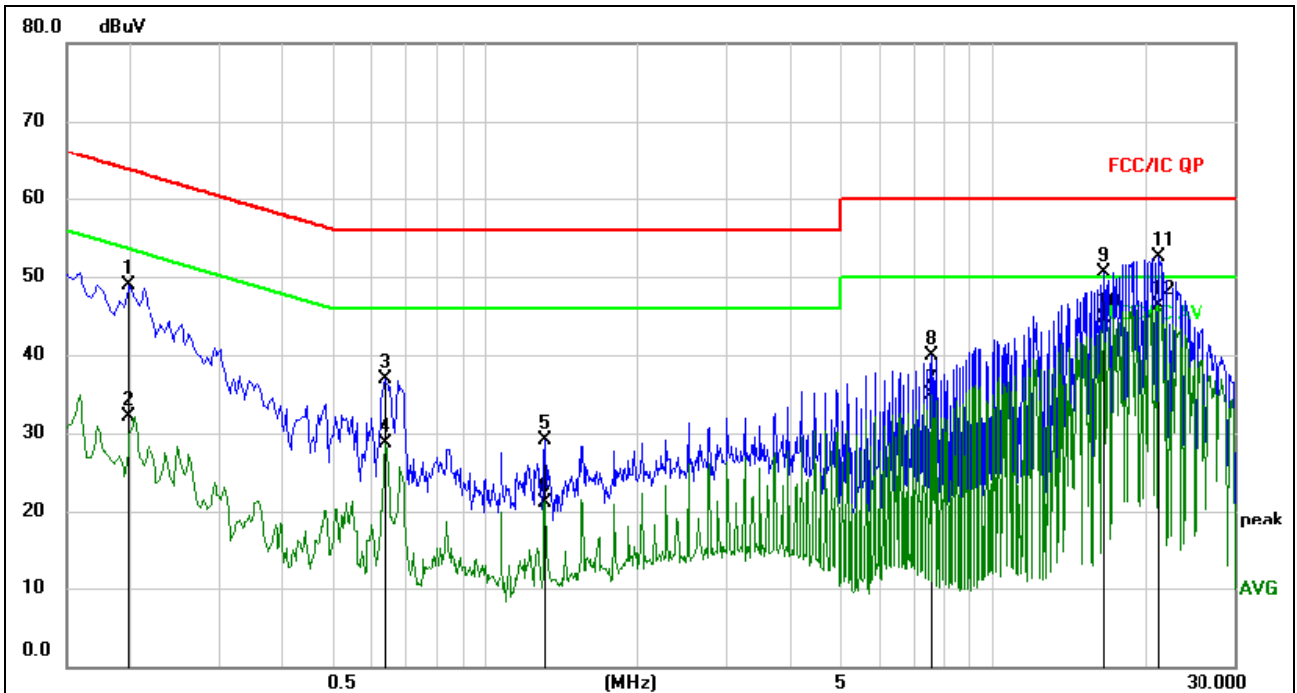

Remark:
 1. All readings are Quasi-Peak and Average values.
 2. Factor = Insertion Loss + Cable Loss.

No.	Mk.	Freq. MHz	Reading Level dBuV	Correct Factor dB	Measure- ment dBuV	Limit dBuV	Over dB	Detector	Comment
1		0.1986	39.33	9.65	48.98	63.67	-14.69	QP	
2		0.1986	22.51	9.65	32.16	53.67	-21.51	AVG	
3		0.6360	27.24	9.68	36.92	56.00	-19.08	QP	
4		0.6360	19.10	9.68	28.78	46.00	-17.22	AVG	
5		1.3168	19.33	9.70	29.03	56.00	-26.97	QP	
6		1.3168	11.50	9.70	21.20	46.00	-24.80	AVG	
7		7.5795	25.05	9.81	34.86	50.00	-15.14	AVG	
8		7.5795	30.17	9.81	39.98	50.00	-10.02	AVG	
9		16.4856	40.58	9.89	50.47	60.00	-9.53	QP	
10		16.4856	34.74	9.89	44.63	50.00	-5.37	AVG	
11		21.1740	42.71	9.84	52.55	60.00	-7.45	QP	
12	*	21.1740	36.49	9.84	46.33	50.00	-3.67	AVG	



EUT:	wireless charging pad	Model Name :	CKWL1021
Temperature:	26 °C	Relative Humidity:	54%
Pressure:	1010hPa	Phase :	N
Test Voltage :	DC 9V For Adapter (adapter input:AC120V/60Hz)	Test Mode:	Charging

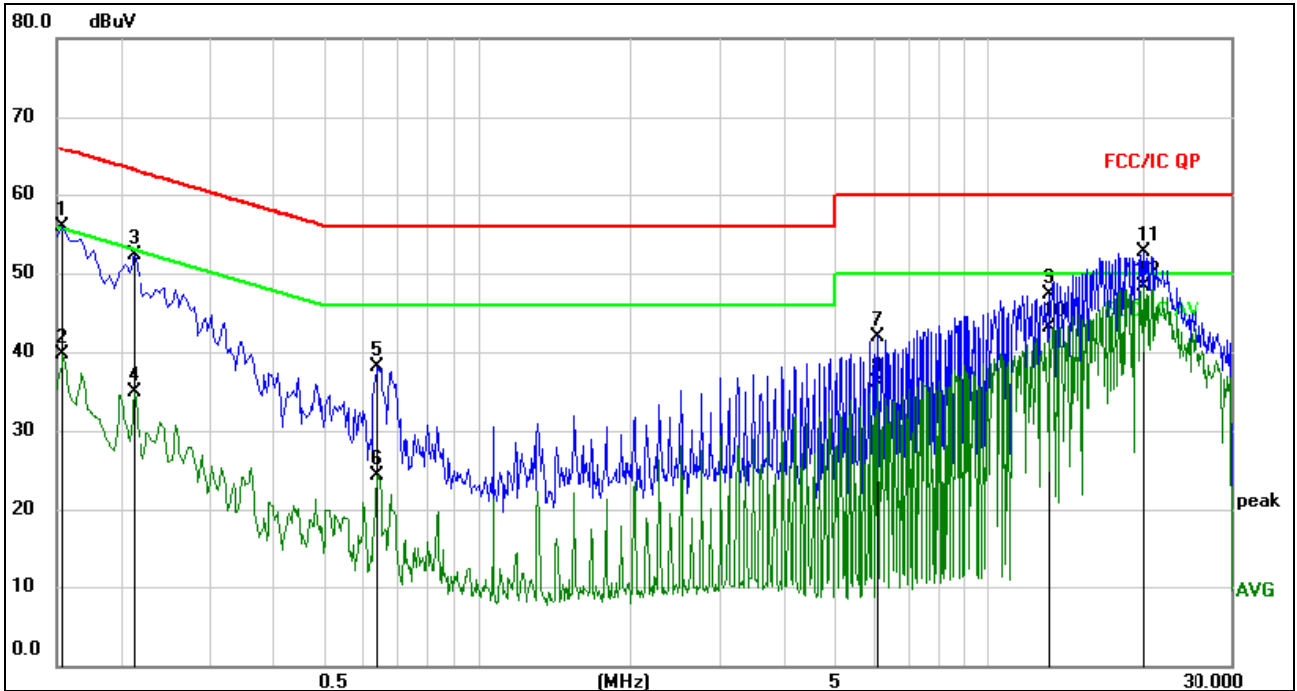

Remark:
 1. All readings are Quasi-Peak and Average values.
 2. Factor = Insertion Loss + Cable Loss.

No.	Mk.	Freq. MHz	Reading Level dBuV	Correct Factor dB	Measure- ment dBuV	Limit dBuV	Over dB	Detector	Comment
1		0.1545	46.18	9.67	55.85	65.75	-9.90	QP	
2		0.1545	29.99	9.67	39.66	55.75	-16.09	AVG	
3		0.2128	42.73	9.65	52.38	63.10	-10.72	QP	
4		0.2128	25.28	9.65	34.93	53.10	-18.17	AVG	
5		0.6372	28.52	9.68	38.20	56.00	-17.80	QP	
6		0.6372	14.64	9.68	24.32	46.00	-21.68	AVG	
7		6.0885	32.22	9.78	42.00	60.00	-18.00	QP	
8		6.0885	26.41	9.78	36.19	50.00	-13.81	AVG	
9		13.2090	37.44	9.84	47.28	60.00	-12.72	QP	
10		13.2090	33.26	9.84	43.10	50.00	-6.90	AVG	
11		20.1345	42.87	9.84	52.71	60.00	-7.29	QP	
12	*	20.1345	38.42	9.84	48.26	50.00	-1.74	AVG	

6. RADIATED EMISSION MEASUREMENT

6.1. Block Diagram of Test Setup

6.1.1. Block Diagram of connection between the EUT and the simulators

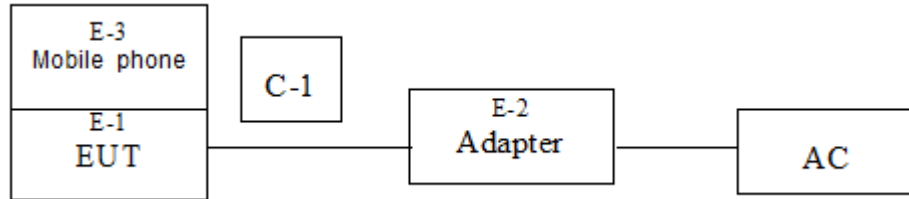

(EUT: wireless charging pad)

6.1.2. Anechoic Chamber Test Setup Diagram

(A) Radiated Emission Test-Up Frequency Below 30MHz

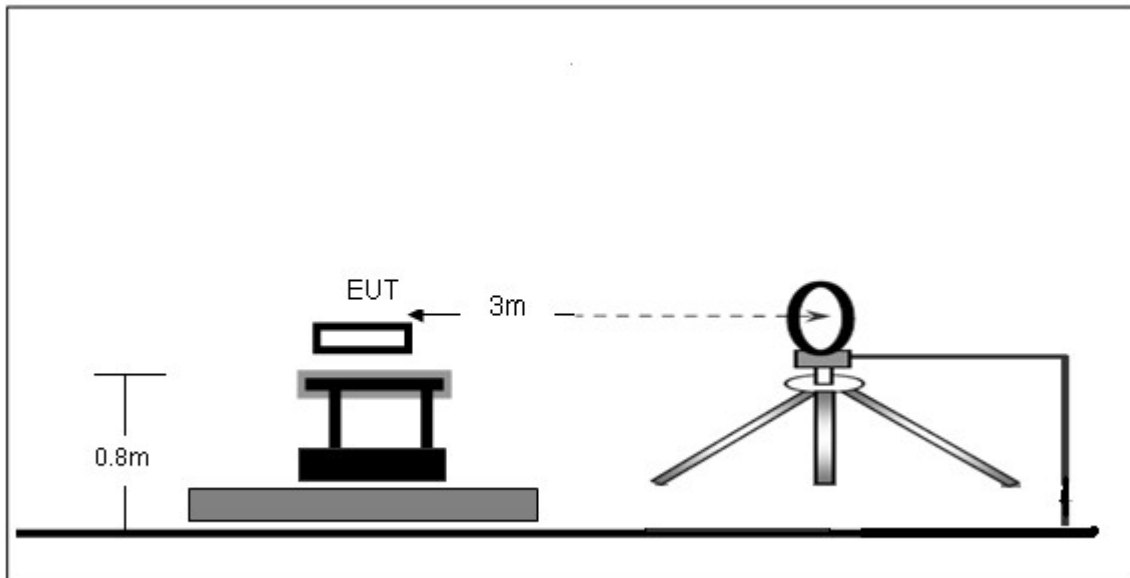

(B) Radiated Emission Test-Up Frequency 30MHz~1GHz

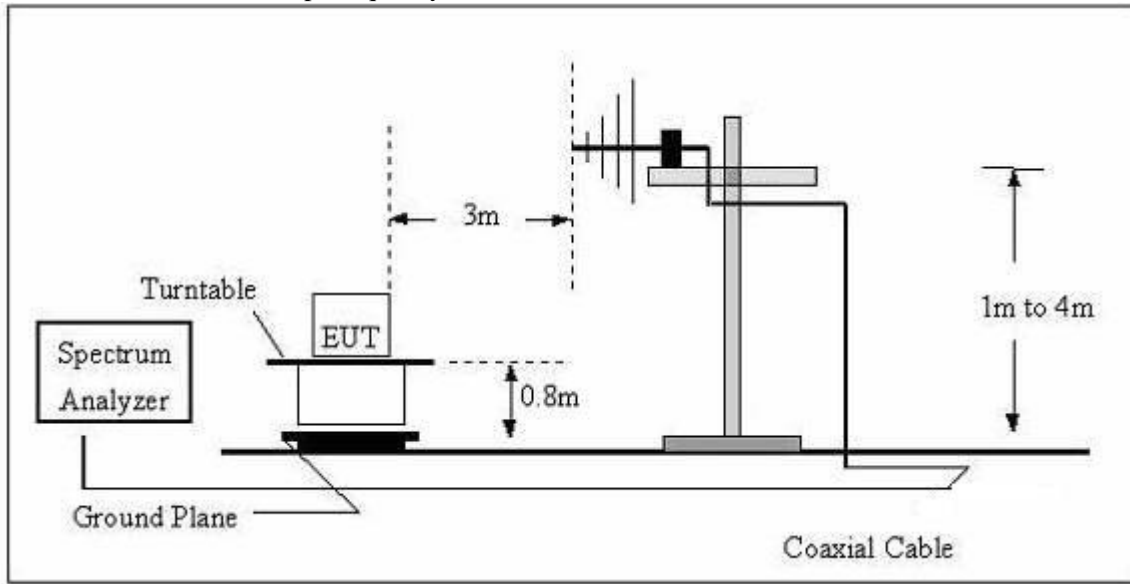

The radiated emission tests were performed in the 3 meters chamber test site, using the setup accordance with the ANSI C63.10-2013. The specification used was the FCC 15.209 and FCC 15.205 limits.

6.2. Test Standard and Limit

FCC §15.209; §15.205

Test Standard	FCC Part15 C Section 15.209 and 15.205				
Test Limit	Frequency (MHz)	Field strength (microvolt/meter)	Limit (dBuV/m)	Remark	Measurement distance (m)
	0.009MHz~0.490MHz	2400/F(kHz)	-	-	300
	0.490MHz-1.705MHz	24000/F(kHz)	-	-	30
	1.705MHz-30MHz	30	-	-	30
	30MHz~88MHz	100	40.0	Quasi-peak	3
	88MHz~216MHz	150	43.5	Quasi-peak	3
	216MHz~960MHz	200	46.0	Quasi-peak	3
	960MHz~1000MHz	500	54.0	Quasi-peak	3
	Above 1000MHz	500	54.0	Average	3
		-	74.0	Peak	3

6.3. EMI Test Receiver Setup

The system was investigated from 9kHz to1GHz.

During the radiated emission test, the EMI test receiver setup was set with the following configurations:



Frequency Range	RBW	Video B/W	Detector
9 kHz – 150 kHz	200 kHz	1 kHz	QP
150 kHz – 30MHz	9kHz	30kHz	QP
30 MHz – 1000 MHz	120 kHz	300 kHz	QP

Note: For the frequency bands 9-90 kHz and 110-490 kHz, the test was based on average detector.

6.4. Test Procedure

The EUT is placed on a turn table which is 0.8 meter above ground. The turn table can rotate 360 degrees to determine the position of the maximum emission level. The EUT is set 3 meters away from the receiving antenna which is mounted on a antenna tower. The antenna can move up and down between 1 to 4 meters to find out the maximum emission level. Broadband antenna (calibrated by dipole antenna) are used as a receiving antenna. Both horizontal and vertical polarization of the antenna are set on measurement.

6.5. Test Result

PASS

Please refer to the following pages.



9kHz-30MHz

EUT:	wireless charging pad	Model Name :	CKWL1021
Temperature:	26 °C	Relative Humidity:	54%
Pressure:	1010 hPa	Polarization :	Horizontal
Test Voltage :	DC 9V For Adapter(adapter intpu:AC120V/60Hz)		
Test Mode :	Normal Link		

Frequency (kHz)	Meter Reading (dBμV)	Factor (dB)	Emission Level (dBμV/m)	Limits (dBμV/m)	Margin (dB)	Detector Type
18.3500	39.02	20.15	59.17	142.33	-83.16	PK
18.3500	34.61	20.15	54.76	122.33	-67.57	AV
48.5700	58.57	20.33	78.90	133.88	-54.98	PK
48.5700	55.54	20.33	75.87	113.88	-38.01	AV
220.6400	69.02	20.55	89.57	120.73	-31.16	PK
220.6400	65.32	20.55	85.87	100.73	-14.86	AV
796.3400	40.89	20.64	61.53	69.58	-8.05	QP
920.2100	36.24	21.26	58.50	68.33	-10.83	QP
1350.2600	31.63	21.26	52.89	65.00	-12.11	QP

Note:

Pre-scan in the all of mode, the worst case in of was recorded.

Factor = antenna factor + cable loss – pre-amplifier.

Margin = Emission Level- Limit.



30MHz-1GHz

EUT:	wireless charging pad	Model Name :	CKWL1021
Temperature:	26 °C	Relative Humidity:	54%
Pressure:	1010 hPa	Polarization :	Horizontal
Test Voltage :	DC 5V For Adapter(adapter input:AC120V/60Hz)		
Test Mode :	Normal Link		

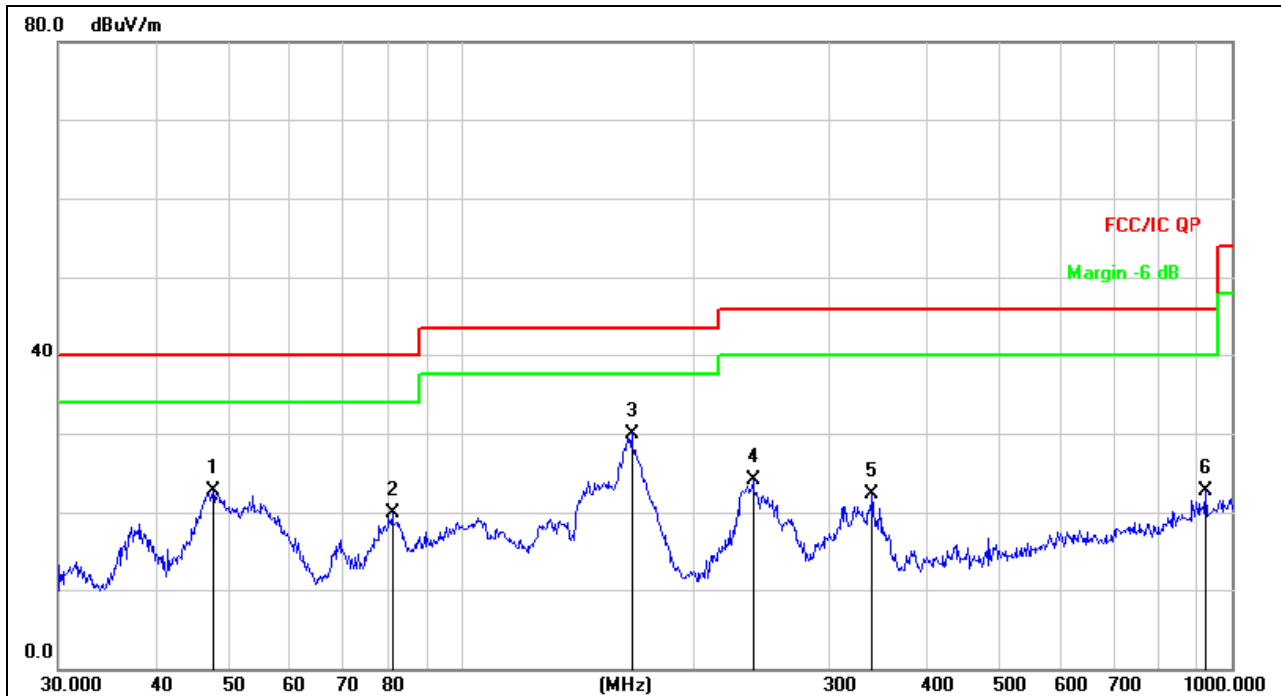

Remark:
Factor = Antenna Factor + Cable Loss – Pre-amplifier.

No.	Mk.	Freq. MHz	Reading Level dBuV	Correct Factor dB	Measure- ment dBuV/m	Limit dB/m	Over dB	Detector
1		47.4918	36.78	-13.99	22.79	40.00	-17.21	QP
2		81.2116	39.35	-19.36	19.99	40.00	-20.01	QP
3	*	166.0680	48.78	-18.78	30.00	43.50	-13.50	QP
4		239.1473	39.60	-15.55	24.05	46.00	-21.95	QP
5		340.7817	34.97	-12.73	22.24	46.00	-23.76	QP
6		925.7563	25.03	-2.26	22.77	46.00	-23.23	QP



EUT:	wireless charging pad	Model Name :	CKWL1021
Temperature:	26 °C	Relative Humidity:	54%
Pressure:	1010 hPa	Polarization :	Vertical
Test Voltage :	DC 5V For Adapter(adapter input:AC120V/60Hz)		
Test Mode :	Normal Link		

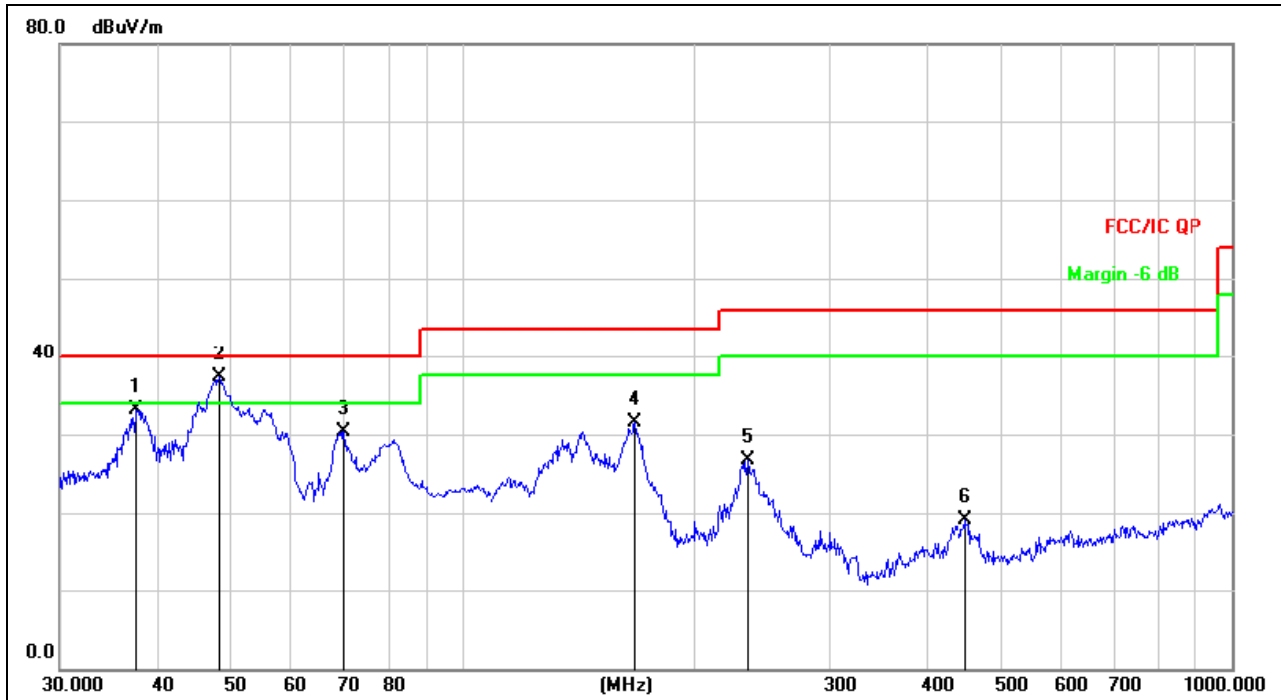

Remark:
Factor = Antenna Factor + Cable Loss – Pre-amplifier.

No.	Mk.	Freq. MHz	Reading Level dBuV	Correct Factor dB	Measure- ment dBuV/m	Limit dB/m	Over dB	Detector
1		37.6798	48.67	-15.55	33.12	40.00	-6.88	QP
2	*	48.1626	51.32	-13.98	37.34	40.00	-2.66	QP
3		70.0903	47.95	-17.61	30.34	40.00	-9.66	QP
4		167.2368	50.20	-18.72	31.48	43.50	-12.02	QP
5		234.9909	42.41	-15.72	26.69	46.00	-19.31	QP
6		449.5557	29.66	-10.60	19.06	46.00	-26.94	QP



EUT:	wireless charging pad	Model Name :	CKWL1021
Temperature:	26 °C	Relative Humidity:	54%
Pressure:	1010 hPa	Polarization :	Horizontal
Test Voltage :	DC 9V For Adapter(adapter input:AC120V/60Hz)		
Test Mode :	Normal Link		

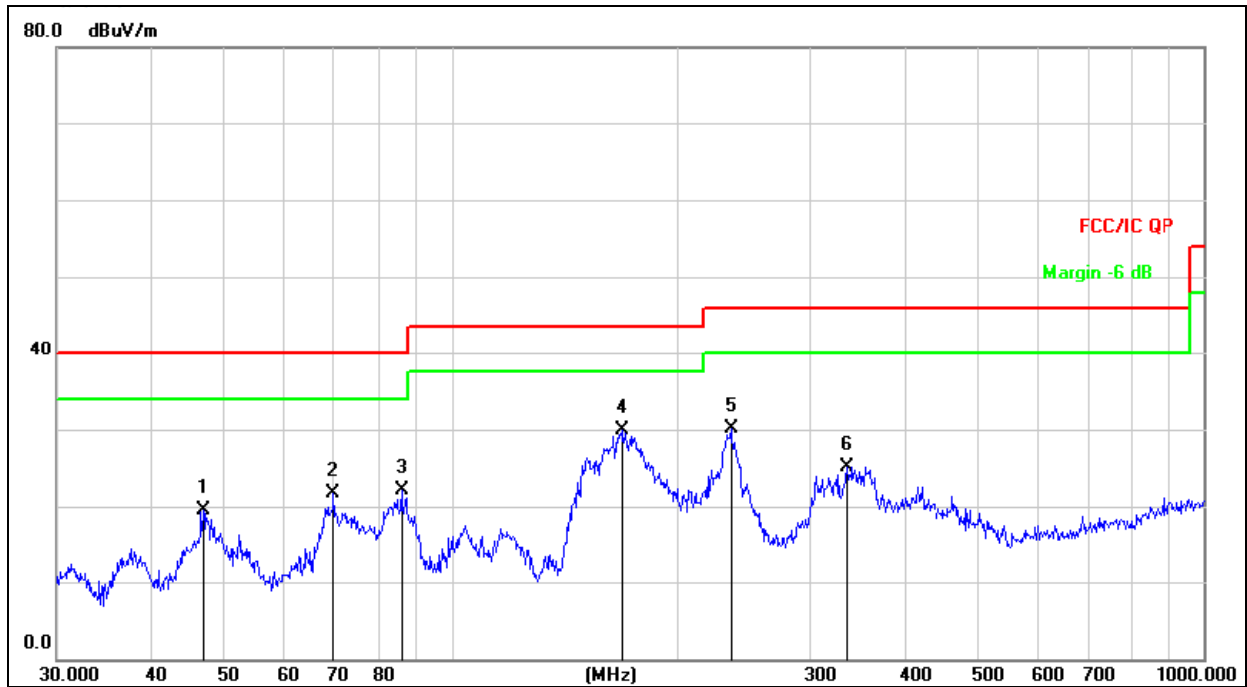

Remark:
Factor = Antenna Factor + Cable Loss – Pre-amplifier.

No.	Mk.	Freq.	Reading Level	Correct Factor	Measurement	Limit	Over	Detector
		MHz	dBuV	dB	dBuV/m	dB/m	dB	
1		46.8303	33.42	-14.00	19.42	40.00	-20.58	QP
2		69.8449	39.18	-17.56	21.62	40.00	-18.38	QP
3		85.8984	40.49	-18.33	22.16	40.00	-17.84	QP
4	*	168.4138	48.62	-18.66	29.96	43.50	-13.54	QP
5		235.8164	45.74	-15.69	30.05	46.00	-15.95	QP
6		334.8589	38.27	-13.07	25.20	46.00	-20.80	QP



EUT:	wireless charging pad	Model Name :	CKWL1021
Temperature:	26 °C	Relative Humidity:	54%
Pressure:	1010 hPa	Polarization :	Vertical
Test Voltage :	DC 9V For Adapter(adapter input:AC120V/60Hz)		
Test Mode :	Normal Link		

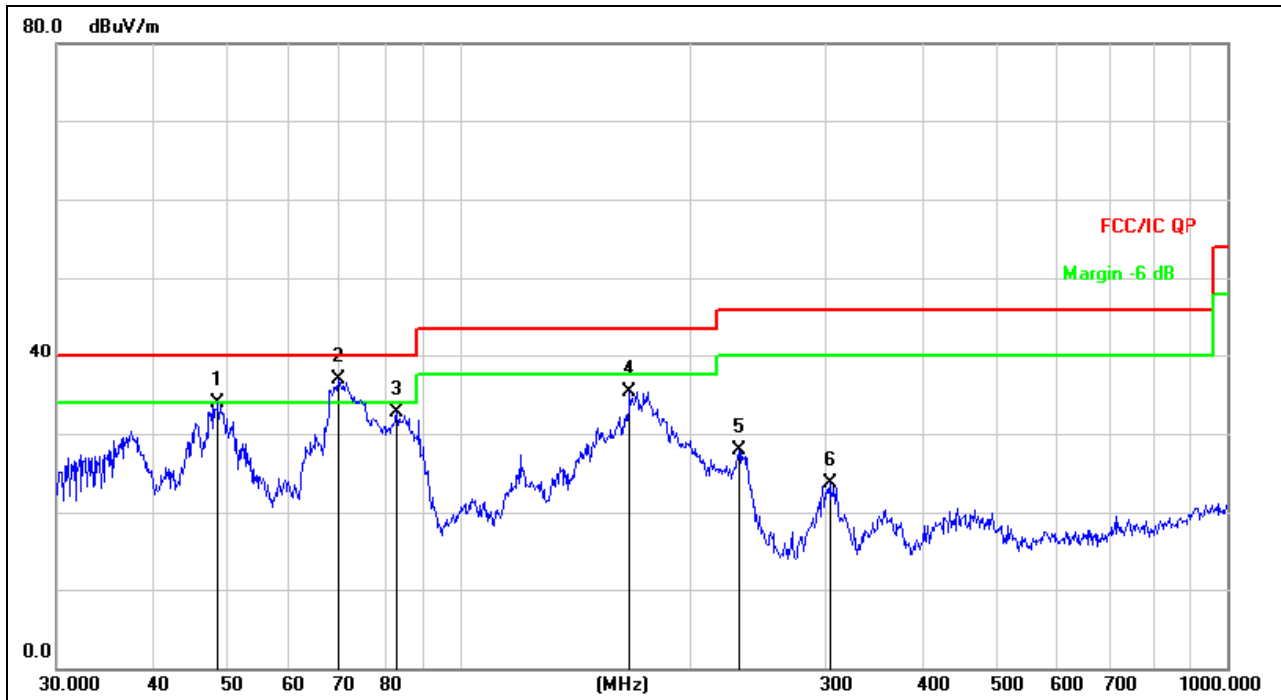

Remark:
Factor = Antenna Factor + Cable Loss – Pre-amplifier.

No.	Mk.	Freq. MHz	Reading Level dBuV	Correct Factor dB	Measure- ment dBuV/m	Limit dB/m	Over dB	Detector
1		48.5016	47.88	-13.97	33.91	40.00	-6.09	QP
2	*	69.8450	54.47	-17.56	36.91	40.00	-3.09	QP
3		82.9385	51.68	-18.98	32.70	40.00	-7.30	QP
4		166.6514	53.97	-18.75	35.22	43.50	-8.28	QP
5		231.7178	43.67	-15.86	27.81	46.00	-18.19	QP
6		303.5437	37.23	-13.47	23.76	46.00	-22.24	QP

7. EUT TEST PHOTOS

Conducted Measurement Photos



Radiated Measurement Photos
9KHz-30MHz



30MHz-1GHz

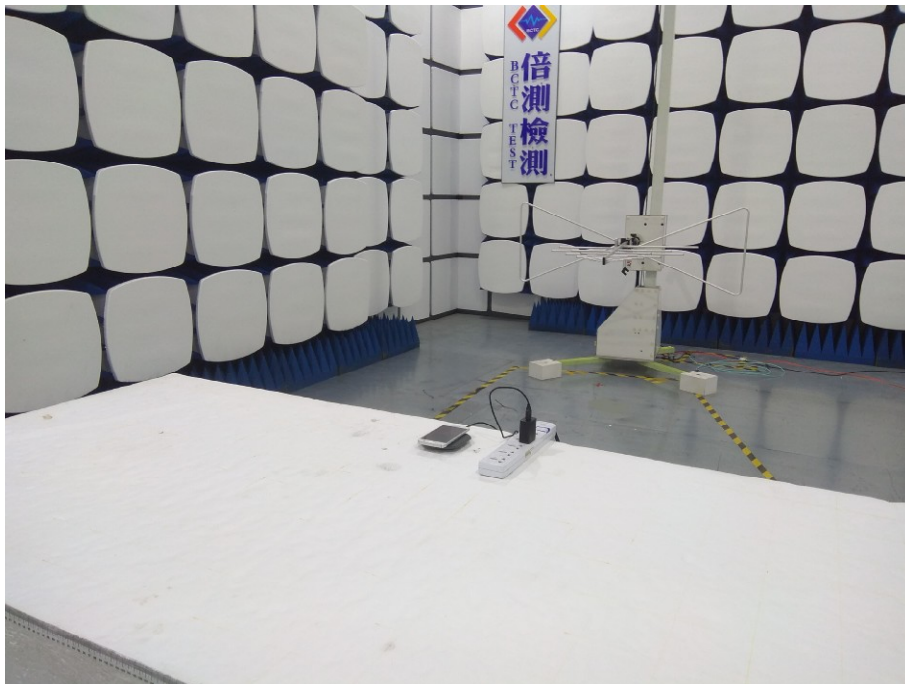

8. EUT PHOTOS



***** END OF REPORT *****