



承認書 APPROVAL SHEET



| | |
|--------------------|-------------------------------------|
| 客戶/Customer: | BeiHai Innotech Technology Co., Ltd |
| 品名/Model: | 自粘線圈 Self-bonded coil |
| 發行號碼/Issue No.: | AP-DG-1804018 |
| 規格/Description: | BT-R5010HU-A11S186 |
| 版本號/Version: | A.0.0 |
| 客戶料號/Customer P/N: | N/A |
| 製作日期/Issue Date: | 2018-04-25 |

| |
|---------------------------------|
| 承認說明/Approval Remark: |
| 客戶回簽/Customer Approval Feedback |
| |

尊敬的客戶:請確認好此份規格承認書後並及時簽回一份給我司。若未簽回,後續貴司正式下單,視同承認此承認書。謝謝! Dear customer: please confirm this specification and signback for us in time.If not sign back, follow-up your company official order shall be regarded as to recognize it. Thank you!

深圳市有勵電子有限公司
BTCOIL ELECTRONICS LIMITED
No.55,the Second Industrial Zone, Houting Village, Shajing Town,
Baoan District, Shenzhen City.PRC 518104
深圳市寶安區沙井鎮後亭村第二工業區第55棟 518104
Tel: 86-755-27223880 Fax: 86-755-27223836
E-mail: qc@btcoil.com

東莞市有勵電子有限公司
BTCOIL ELECTRONICS(Dongguan) LIMITED
No.336,the 3rd Zone Wushiling, Yangwu Village, Dalang Town,
Dongguan City, Guangdong Province.PRC 523789
廣東省東莞市大朗鎮洋烏村烏石嶺三區336號 523789
Tel: 86-769-8923 8020 Fax: 86-769-8310 0273
E-mail: qc-dg@btoil.com

中山有匯電子有限公司
BTCOIL ELECTRONICS (Zhongshan) LIMITED
3/F building C, Baishawan Industrial Zone,Yangtze river North
Road,Zhongshan City,Guangdong Province.PRC 528403
中山市東區長江北路北段白沙灣工業園C幢三樓
Tel: 86-760-23889250 Fax: 86-760-23889253
E-mail: qc-zs@btoil.com

有勵電子(昆山)有限公司
BTCOIL ELECTRONICS (Kunshan) LIMITED
No. 168, Xinji Road,Bacheng Town,Kunshan City,Jiangsu Province.
PRC 215300
江蘇省昆山市巴城鎮欣基路168號
Tel: 86-512-5706 5767 Fax: 86-512-5706 5769
E-mail: qc-ks@btoil.com

業務單位/Sales Dep:

| 核准 APPROVED | 審查 CHECKED |
|----------------|---------------|
| 黄爱生 | 叶世麟 |

工程單位/Engineering Unit

| 核准 APPROVED | 審查 CHECKED | 製圖 DRAWN |
|----------------|---------------|-------------|
| 刘春雨 | 欧奇林 | 廖水秀 |

承認書 APPROVAL SHEET

| | | | | | |
|----------------------|-----|----------------------|--------------------|-------------------|---------------|
| 客戶 Customer | 嘉信高 | 規格 Description | BT-R5010HU-A11S186 | 發行號碼 Issue No. | AP-DG-1804018 |
| 客戶料號 Customer P/N | N/A | 客戶圖號 Customer Doc | N/A | 版本號 Version | A.0.0 |

1.尺寸 Dimension(unit: mm):

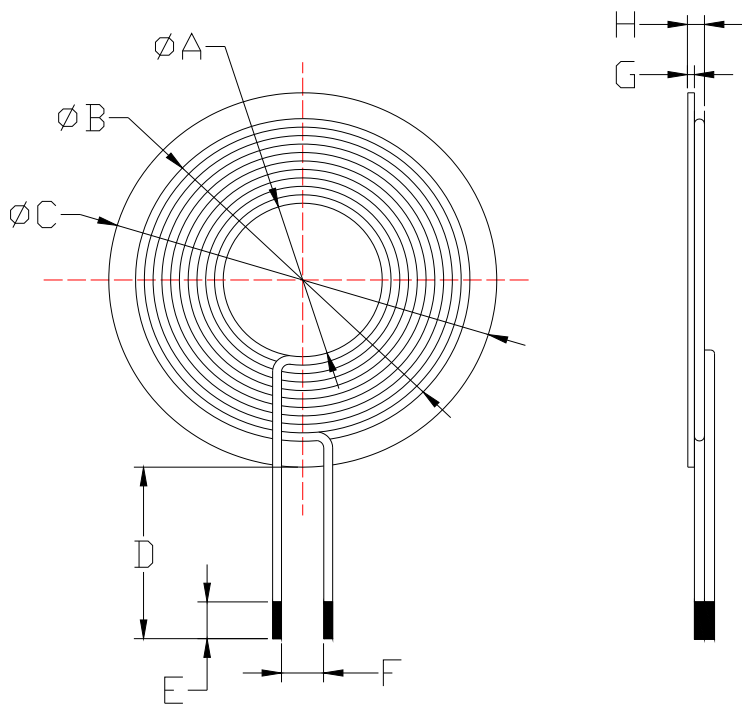

| 位置 Position | 尺寸 Dimension | 公差 Tolerance |
|----------------|-----------------|-----------------|
| A | 20.5 | ± 0.5 |
| B | 43.0 | ± 0.1 |
| C | 50.0 | ± 1.0 |
| D | 25.0 | ± 2.0 |
| E | 4.5 | ± 1.5 |
| F | 5.0 | ± 2.0 |
| G | 1.0 | ± 0.15 |
| H | 2.7 | MAX |
| | | |
| | | |

2.备注 Note:

- (1) Anti-clockwise way of winding. Turns:10TS,single layer.
- (2) Two leads are cross.
- (3) Inductance:6.3uH $\pm 10\%$ (100KHz/1V), Resistance:50.0 m Ω MAX (25 $^{\circ}$ C) ;
- (4) Materials meet the RoHS and Reach standard.

3.材料清單 Raw material:

| No. | 材料 Material | 規格型號 DescriptionPart No. | 供應商1 Supplier1 | 供應商2 Supplier2 | 供應方式 Method of Supply | 備註 Note |
|-----|------------------------------------|--|-------------------|-------------------|--------------------------|------------|
| 1 | 丙酮丝包线 Acetone silk-covered wire | $\Phi 0.08*105P$ 2UEW-F/BT UDTC/155 (L20.5*0.08*105P*10TS) | BTB-253 | | 自購 Self-buying | |
| 2 | 磁片 | PC95 50.0*1.0MM | BTB-346 | BTB-326 | 自購 Self-buying | |
| 3 | 無鉛錫 Lead-free tin | M20E Sn99.3Cu0.7 | BTB-330 | | 自購 Self-buying | |
| 4 | 胶水 Glue | AS-1008W 白胶 | BTB-326 | | 自購 Self-buying | |

(製圖)DRAWN: 廖水秀 (審查)CHECKED: 欧奇林 (核准) APPROVED: 刘春雨 (客户)Customer: