

onn.™

MED LED Speaker
Quick Start Guide

What's in the Box?

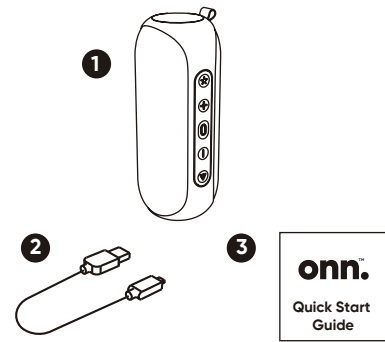

- 1. Bluetooth Speaker
- 2. Charging Cable
- 3. Quick Start Guide

Get to Know MED LED Speaker

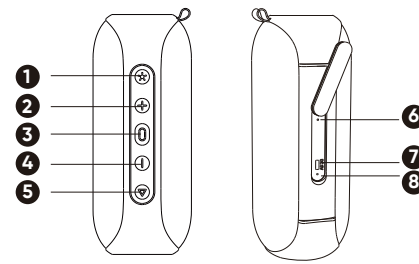

- 1. Light key
- 2. Volume +
- 3. Power
- 4. Volume -
- 5. Play / Pause
- 6. Reset key
- 7. Charging port
- 8. Charging indicator

Power on/off & Bluetooth Pairing

01

Press power button for 2s to turn on or turn off.

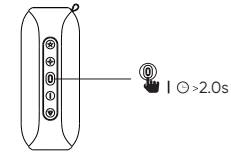

Bluetooth will be activated upon powering on the device. Use phone to search device's pairing name " onn. DUAL LED SPK GRY ", Click pairing name for connection and pairing.

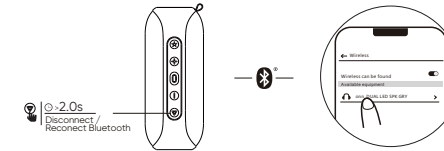

Play music/Light mode

02

Short press "♥" button to execute play and pause.
Short press volume "-" to reduce volume.
Long press volume "-" to previous song.
Short press volume "+" to increase volume.
Long press volume "+" to next song.

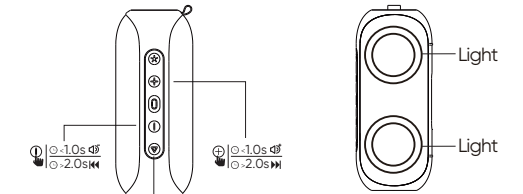

- * Short press x1 Lighting effect switch
- * Short press x2 Lighting on / off

Answer/End/Reject a call

03

Short press "♥" button to answer incoming calls.
Short press "♥" to end the call.
Short press "♥" button x2 to make the last call.
Long press "♥" button for 2s to reject a call.

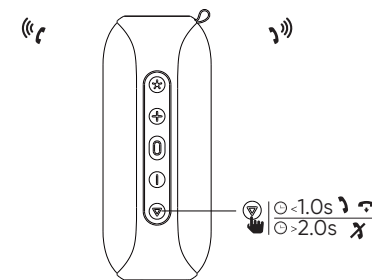

Pairing two speakers together

04

Power on one speaker, then short press "@" x2 to enter into TWS pairing mode, this device will be the master. Then power on 2nd speaker, it will connect to the master automatically.
After two speakers are paired successfully, use your mobile device to pair with master speaker utilizing bluetooth pairing method.

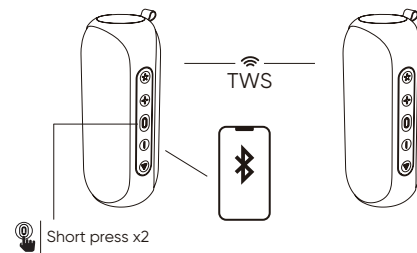

Clear pairing records and reset speaker

05

Press "♥" for 8s, all pairing records will be cleared.
In case you face any difficulties with your product, simply insert an insulated pointed object (eg-toothpick) inside the reset key to restart & reboot your device.

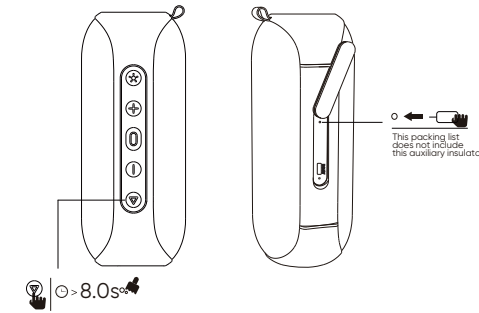

Charging and connect outside audio

06

We do not recommend using a USB charging device that is not 5V DC output.
To preserve battery lifespan, fully charge at least once every 45 days.

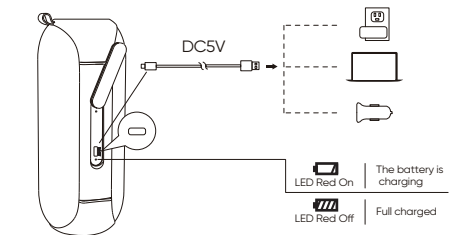

Need help?
We're here for you every day from 7 a.m. - 9 p.m. CST.
Give us a call at 1-888-516-2630

©2021 Walmart
onn. is a trademark of Walmart
All Rights Reserved.



We'd love to hear from you. Scan with your Walmart app and let us know what you think.

80

80*5P



赣州得辉达科技有限公司
GANZHOU DEHUIDA ELECTRONICS CO.,LTD.

机型:BM2020
料号:
品名:警告书
版本: 1.0

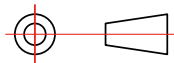

A 4 单位: mm

材质要求: 如描述	绘图:
表面处理: 如描述	审核:
比例: 1: 1	批准:
页数: 1	生效日期: 2021.10.21

版本	描述	日期
1.0	初步发行	2021.10.21

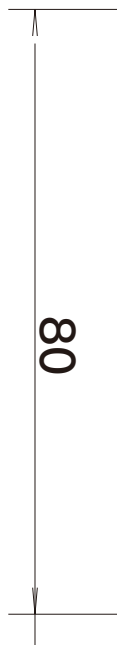

80

WARNING

Changes or modifications to this unit not expressly approved by the party responsible for compliance could void the user's authority to operate the equipment.
NOTE: This equipment has been tested and found to comply with the limits for a Class B digital device, pursuant to Part 15 of the FCC Rules. These limits are designed to provide reasonable protection against harmful interference in a residential installation. This equipment generates, uses and can radiate radio frequency energy and, if not installed and used in accordance with the instructions, may cause harmful interference to radio communications.

However, there is no guarantee that interference will not occur in a particular installation. If this equipment does cause harmful interference to radio or television reception, which can be determined by turning the equipment off and on, the user is encouraged to try to correct the interference by one or more of the following measures:

- Reorient or relocate the receiving antenna.
- Increase the separation between the equipment and receiver.
- Connect the equipment into an outlet on a circuit different from that to which the receiver is connected.
- Consult the dealer or an experienced radio/TV technician for help.

This device complies with Part 15 of the FCC Rules. Operation is subject to the following two conditions:
(1) this device may not cause harmful interference, and
(2) this device must accept any interference received, including interference that may cause undesired operation.

Need help?
We're here for you every day from 7 a.m. – 9 p.m. CST. Give us a call at 1-888-516-2630

Party sync mode compatible model list:

<u>AAABLU100006839</u>	<u>AAABLU100006889</u>
<u>AAAGRY100006839</u>	<u>AAAGRY100006889</u>
<u>AAAAQU100006839</u>	<u>100008734</u>
<u>AAAGRY100006897</u>	<u>100008736</u>
<u>AAAAQU100006897</u>	<u>AAAGRY100006896</u>
<u>AAAGRY100006902</u>	<u>AAAGRY100006838</u>
<u>AAAGRY100077176</u>	<u>AAALAV100077176</u>
<u>AAAGRY100076173</u>	<u>AAABLU100076173</u>
<u>AAALAV100076173</u>	

80

技术要求:

1. W80*H80mm 80g书纸双面印黑 沃尔玛通用 环保。
2. 其它未标注尺寸及公差请参照图档及公差表。

ROHS HF REACH CA65

尺寸公差: +/-1mm