



FCC RADIO TEST REPORT

Applicant : SACKit ApS

Address : Lyngvej 1, DK-9000 Aalborg

Equipment : Bluetooth Speaker

Model No. : WOOFit Go XQ , WOOFit Go Qi, WOOFit Go
xx(x=A-Z,a-z or blank)

Trade Name : CVTE , SACKit , MUVIT , Symfoni , Sandstrom

FCC ID : 2A05W-WOOFITGOXQ

I HEREBY CERTIFY THAT :

The sample was received on Apr. 15, 2020 and the testing was completed on Apr. 23, 2020 at CerpPASS Technology (Suzhou) Co., Ltd. The test result refers exclusively to the test presented test model / sample. Without written approval of CerpPASS Technology (Suzhou) Co., Ltd., the test report shall not be reproduced except in full.

Approved by:



Miro Chueh
EMC/RF Manager

Laboratory Accreditation:

CerpPASS Technology Corporation Test Laboratory

TAF LAB Code: 1439

CerpPASS Technology (SuZhou) Co., Ltd.

A2LA LAB Code: 4981.01



Contents

1. Summary of Test Procedure and Test Results.....	5
1.1 Applicable Standards	5
2. Test Configuration of Equipment under Test.....	6
2.1 Feature of Equipment under Test.....	6
2.2 Carrier Frequency of Channels.....	6
2.3 Test Mode and Test Software.....	7
2.4 Description of Test System.....	7
2.5 General Information of Test.....	8
2.6 Measurement Uncertainty	9
3. Test Equipment and Ancillaries Used for Tests	10
4. Antenna Requirements.....	11
4.1 Standard Applicable	11
4.2 Antenna Construction and Directional Gain.....	11
5. Test of Conducted Emission.....	12
5.1 Test Limit	12
5.2 Test Procedures	12
5.3 Typical Test Setup	13
5.4 Test Result and Data.....	14
6. Test of Spurious Emission (Radiated)	16
6.1 Test Limit	16
6.2 Test Procedures	16
6.3 Typical Test Setup	17
6.4 Test Result and Data (9kHz ~ 30MHz).....	18
6.5 Test Result and Data (30MHz ~ 1GHz).....	18
6.6 Test Result and Data (1GHz ~ 25GHz).....	20
6.7 Restricted Bands of Operation.....	26
7. Test of Spurious Emission (Conducted).....	27
7.1 Test Limit	27
7.2 Test Procedure	27
7.3 Test Setup Layout	27
7.4 Test Result and Data.....	27
8. 6dB Bandwidth Measurement Data	29
8.1 Test Limit	29
8.2 Test Procedures	29
8.3 Test Setup Layout	29
8.4 Test Result and Data.....	29
9. Maximum Peak and Average Output Power.....	31
9.1 Test Limit	31
9.2 Test Procedures	31
9.3 Test Setup Layout	31
9.4 Test Result and Data.....	31
10. Power Spectral Density	32
10.1 Test Limit	32
10.2 Test Procedures	32



10.3 Test Setup Layout 32
10.4 Test Result and Data 33



1. Summary of Test Procedure and Test Results

1.1 Applicable Standards

ANSI C63.4:2014

ANSI C63.10:2013

FCC Rules and Regulations Part 15 Subpart C §15.247

FCC Rule	Description of Test	Result
15.203	Antenna Requirement	PASS
15.207	AC Power Line Conducted Emission	PASS
15.209 15.205	Radiated Spurious Emission	PASS
15.247(d)	Conducted Spurious Emission	PASS
15.247(a)(2)	6dB Bandwidth	PASS
15.247(b)	Maximum Peak Output Power	PASS
15.247(e)	Power Spectral Density	PASS

*The principle of judgment is made according to the laboratory's reporting control and measurement uncertainty standard procedures.



2. Test Configuration of Equipment under Test

2.1 Feature of Equipment under Test

Equipment	Bluetooth Speaker
Model Name	WOOFit Go XQ , WOOFit Go Qi, WOOFit Go xx(x=A-Z,a-z or blank) Model WOOFit Go XQ is the representative for final test.
Model Discrepancy	All models are electrically identical, different model names are for marketing purpose.
Modulation Type	GFSK
Frequency Range	2400 – 2483.5 MHz
Channel Number	40
Data Rate	1Mbps
Power Source	3.7V 3.5Wh Li-ion Battery (build-in) DC 5V charged by USB port

2.2 Carrier Frequency of Channels

Channel	Frequency (MHz)	Channel	Frequency (MHz)	Channel	Frequency (MHz)
*00	2402	14	2430	28	2458
01	2404	15	2432	29	2460
02	2406	16	2434	30	2462
03	2408	17	2436	31	2464
04	2410	18	2438	32	2466
05	2412	*19	2440	33	2468
06	2414	20	2442	34	2470
07	2416	21	2444	35	2472
08	2418	22	2446	36	2474
09	2420	23	2448	37	2476
10	2422	24	2450	38	2478
11	2424	25	2452	*39	2480
12	2426	26	2454	--	--
13	2428	27	2456	--	--

Note: Channels remarked * are selected to perform test.



2.3 Test Mode and Test Software

- a. During testing, the interface cables and equipment positions were varied according to ANSI C63.10.
- b. The complete test system included Notebook and EUT for RF test.
- c. An executive program, " **FCC_assist.exe**" under Android was executed to transmit and receive data via Bluetooth.
- d. The following test modes were performed for the test:
Test Mode 1. GFSK (1Mbps)

2.4 Description of Test System

Device	Manufacturer	Model No.	Description
Notebook	Sony	PCG-71811P	R33021

Used cable

Cable	Quantity	Description
Type-C Cable	1	0.3m Non Shielding



2.5 General Information of Test

<input type="checkbox"/>	Test Site	CerpPASS Technology Corporation Test Laboratory Address: No.10, Ln. 2, Lianfu St., Luzhu Dist., Taoyuan City 33848, Taiwan (R.O.C.) Tel:+886-3-3226-888 Fax:+886-3-3226-881
	TAF	1439
	FCC	TW1079, TW1061
	IC	4934E-1, 4934E-2
	VCCI	T-2205 for Telecommunication Test C-4663 for Conducted emission test R-4399, R-4218 for Radiated emission test G-812, G-813 for radiated disturbance above 1GHz
<input checked="" type="checkbox"/>	Test Site	CerpPASS Technology (Suzhou) Co.,Ltd Address: No.66,Tangzhuang Road, Suzhou Industrial Park, Jiangsu 215006, China Tel: +86-512-6917-5888 Fax: +86-512-6917-5666
	CNAS	L5515
	FCC	CN1243
	A2LA	4981.01
	IC	7290A
	VCCI	T-11945 for Telecommunication Test C-12919 for Conducted emission test R-12670 for Radiated emission test G-10227 for radiated disturbance above 1GHz



2.6 Measurement Uncertainty

ISO/IEC 17025 requires that an estimate of the measurement uncertainties associated with the emissions test results be included in the report. The measurement uncertainties given below are based on a 95% confidence level (based on a coverage factor (k=2)).

RF Conducted Measurement

Test Item	Uncertainty	Limit
Radio Frequency	$\pm 8.7 \times 10^{-7}$	$\pm 1 \times 10^{-5}$
RF output power, conducted	$\pm 0.63\text{dB}$	$\pm 1.5\text{dB}$
Power density, conducted	$\pm 1.21\text{dB}$	$\pm 3\text{dB}$
Unwanted emissions, conducted	30-1000MHz	$\pm 0.51\text{dB}$
	1-25GHz	$\pm 0.67\text{dB}$
All emissions, radiated	30-1000MHz	$\pm 2.28\text{dB}$
	1-25GHz	$\pm 2.59\text{dB}$
Temperature	$\pm 0.8^\circ\text{C}$	$\pm 1^\circ\text{C}$
Humidity	$\pm 3\%$	$\pm 5\%$
DC and low frequency voltages	$\pm 3\%$	$\pm 3\%$



3. Test Equipment and Ancillaries Used for Tests

Instrument/Ancillary	Manufacturer	Model No.	Serial No.	Calibration Date	Valid Date.
EMI Receiver	R&S	ESCI3	100563	2019.06.21	2020.06.20
LISN	Schwarzbeck	NSLK 8127	8127-920	2019.09.25	2020.09.24
Pulse Limiter	R&S	ESH3-Z2	100529	2020.03.11	2021.03.10
Software	Farad	Ez-EMC	ver.ct3a1	N/A	N/A

Instrument/Ancillary	Manufacturer	Model No.	Serial No.	Calibration Date	Valid Date.
Bilog Antenna	Sunol	JB1	A072414-2 -2	2019.07.13	2020.07.13
EMI Receiver	R&S	ESCI3	101183	2019.06.28	2020.06.27
EMI Receiver	R&S	ESCI7	100968	2019.07.28	2020.07.27
Preamplifier	EM Electronics corp.	EM330	60618	2020.03.11	2021.03.10
Horn Antenna	Schwarzbeck	BBHA9120 D	9120D-619	2019.07.13	2020.07.13
Horn Antenna	Schwarzbeck	BBHA9170	9170-348	2019.06.23	2020.06.22
Spectrum Analyzer	R&S	FSP40	100324	2019.07.13	2020.07.12
Preamplifier	EMCI	EMCI 030-00-3230	SN016723	2020.03.11	2021.03.10
Preamplifier	EM Electronics corp.	EM01G18G	SN060714	2020.03.23	2021.03.22
Spectrum Analyzer	KEYSIGHT	N9010A	MY53400169	2019.08.25	2020.08.24
Software	E3	AUDIX	Version: 8.14.806b	N/A	N/A



4. Antenna Requirements

4.1 Standard Applicable

For intentional device, according to FCC 47 CFR Section 15.203, an intentional radiator shall be designed to ensure that no antenna other than that furnished by the responsible party shall be used with the device.

And according to FCC 47 CFR Section 15.247 (b), if transmitting antennas of directional gain greater than 6dBi are used, the power shall be reduced by the amount in dB that the directional gain of the antenna exceeds 6dBi.

4.2 Antenna Construction and Directional Gain

Antenna Type	Antenna Gain
PCB Antenna	1.5dBi



5. Test of Conducted Emission

5.1 Test Limit

Conducted Emissions were measured from 150 kHz to 30 MHz with a bandwidth of 9 KHz on the 120 VAC power and return leads of the EUT according to the methods defined in ANSI C63.10-2013. The EUT was placed on a nonmetallic stand in a shielded room 0.8 meters above the ground plane as shown in section 6.2.2. The interface cables and equipment positioning were varied within limits of reasonable applications to determine the position produced maximum conducted emissions

Frequency (MHz)	Quasi Peak (dB μ V)	Average (dB μ V)
0.15 – 0.5	66-56*	56-46*
0.5 – 5.0	56	46
5.0 – 30.0	60	50

*Decreases with the logarithm of the frequency.

5.2 Test Procedures

- a. The EUT was placed 0.4 meter from the conducting wall of the shielding room was kept at least 80 centimeters from any other grounded conducting surface.
- b. Connect EUT to the power mains through a line impedance stabilization network (LISN).
- c. All the support units are connecting to the other LISN.
- d. The LISN provides 50 ohm coupling impedance for the measuring instrument.
- e. The FCC states that a 50 ohm, 50 micro-Henry LISN should be used.
- f. Both sides of AC line were checked for maximum conducted interference.
- g. The frequency range from 150 kHz to 30 MHz was searched.
- h. Set the test-receiver system to Peak Detect Function and Specified Bandwidth with Maximum Hold Mode.



5.3 Typical Test Setup

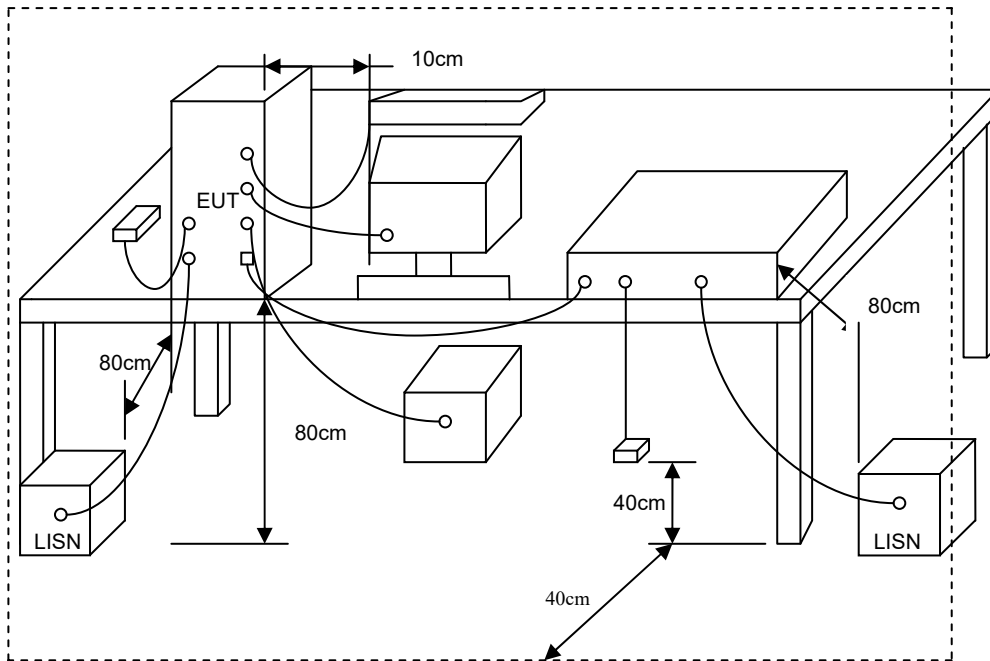



5.4 Test Result and Data

Test Mode :	Normal Link		
AC Power :	AC 120V/60Hz	Phase:	LINE
Temperature :	26°C	Humidity:	60%
Pressure(mbar) :	1002	Date:	2020-04-20

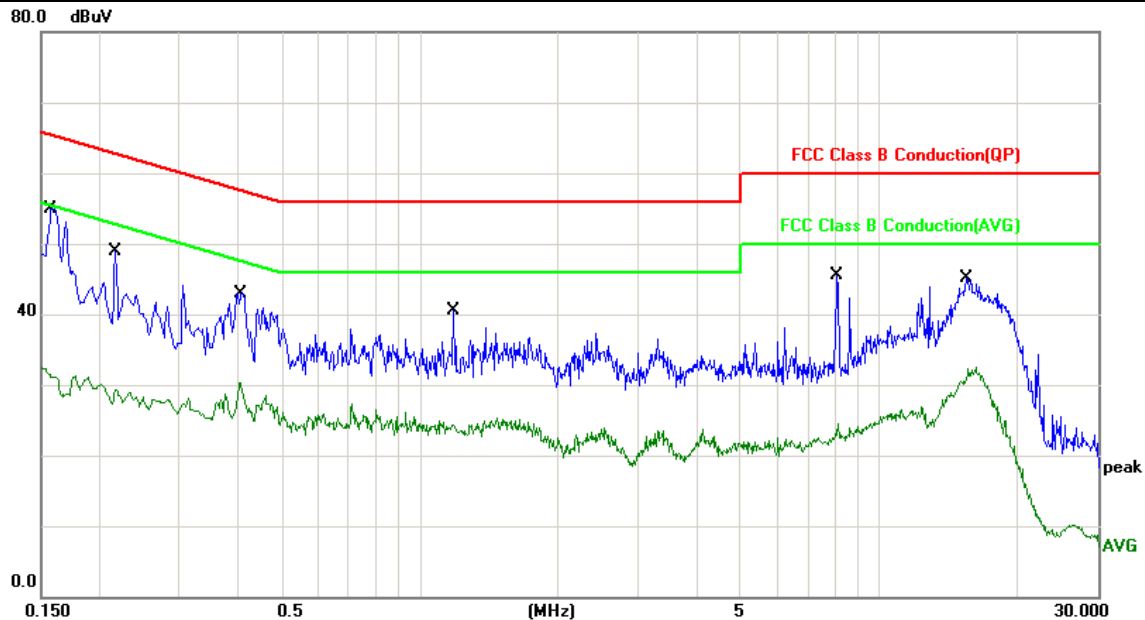

No.	Frequency (MHz)	Factor (dB)	Reading (dBuV)	Level (dBuV)	Limit (dBuV)	Margin (dB)	Detector
1	0.1580	10.06	40.33	50.39	65.56	-15.17	QP
2	0.1580	10.06	22.32	32.38	55.56	-23.18	AVG
3	0.2180	10.05	36.32	46.37	62.89	-16.52	QP
4	0.2180	10.05	19.49	29.54	52.89	-23.35	AVG
5	0.4100	9.94	30.97	40.91	57.65	-16.74	QP
6	0.4100	9.94	19.55	29.49	47.65	-18.16	AVG
7	1.1900	10.31	19.16	29.47	56.00	-26.53	QP
8	1.1900	10.31	13.37	23.68	46.00	-22.32	AVG
9	8.1180	10.25	17.57	27.82	60.00	-32.18	QP
10	8.1180	10.25	11.73	21.98	50.00	-28.02	AVG
11	15.5140	10.39	27.31	37.70	60.00	-22.30	QP
12	15.5140	10.39	19.70	30.09	50.00	-19.91	AVG

Note: Measurement Level = Reading Level + Correct Factor



Test Mode :	Normal Link		
AC Power :	AC 120V/60Hz	Phase:	NEUTRAL
Temperature :	26°C	Humidity:	60%
Pressure(mbar) :	1002	Date:	2020-04-20

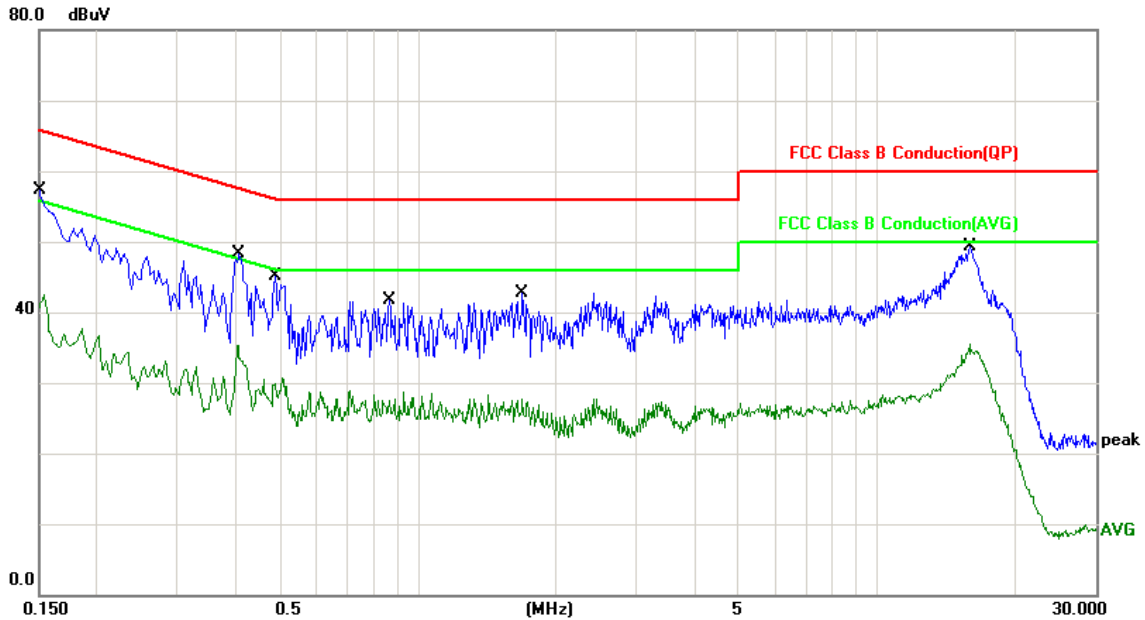

No.	Frequency (MHz)	Factor (dB)	Reading (dBuV)	Level (dBuV)	Limit (dBuV)	Margin (dB)	Detector
1	0.1500	10.06	40.08	50.14	65.99	-15.85	QP
2	0.1500	10.06	26.12	36.18	55.99	-19.81	AVG
3	0.4100	9.94	36.07	46.01	57.65	-11.64	QP
4	0.4100	9.94	24.14	34.08	47.65	-13.57	AVG
5	0.4900	9.90	33.27	43.17	56.17	-13.00	QP
6	0.4900	9.90	22.95	32.85	46.17	-13.32	AVG
7	0.8700	10.10	26.80	36.90	56.00	-19.10	QP
8	0.8700	10.10	16.25	26.35	46.00	-19.65	AVG
9	1.6980	10.15	27.25	37.40	56.00	-18.60	QP
10	1.6980	10.15	16.37	26.52	46.00	-19.48	AVG
11	16.0540	10.41	31.69	42.10	60.00	-17.90	QP
12	16.0540	10.41	23.25	33.66	50.00	-16.34	AVG

Note: Measurement Level = Reading Level + Correct Factor



6. Test of Spurious Emission (Radiated)

6.1 Test Limit

In any 100kHz bandwidth outside the frequency band in which the spread spectrum or digitally modulated intentional radiator is operating, the radio frequency power that is produced by the intentional radiator shall be at least 20dB below that in the 100kHz bandwidth within the band that contains the highest level of the desired power, based on either an RF conducted or a radiated measurement. If the transmitter measurement is based on the maximum conducted output power, the attenuation required under this paragraph shall be 30dB instead of 20dB. In addition, radiated emissions which fall in section 15.205(a) the restricted bands must also comply with the radiated emission limit specified in section 15.209(a).

Frequency (MHz)	Field Strength (microvolt/meter)	Measurement Distance (meters)
0.009 ~ 0.490	2400/F(kHz)	300
0.490 ~ 1.705	24000/F(kHz)	30
1.705 ~ 30.0	30	30
30 ~ 88	100	3
88 ~ 216	150	3
216 ~ 960	200	3
Above 960	500	3

6.2 Test Procedures

- The EUT was placed on a rotatable table top 0.8 meter above ground.
- The EUT was set 3 meters from the interference receiving antenna which was mounted on the top of a variable height antenna tower.
- The table was rotated 360 degrees to determine the position of the highest radiation.
- The antenna is a broadband antenna and its height is varied between one meter and four meters above ground to find the maximum value of the field strength both horizontal polarization and vertical polarization of the antenna are set to make the measurement.
- For each suspected emission the EUT was arranged to its worst case and then tune the antenna tower (from 1 M to 4 M) and turn table (from 0 degree to 360 degrees) to find the maximum reading.
- Set the test-receiver system to Peak or CISPR quasi-peak Detect Function and specified bandwidth with Maximum Hold Mode.
- If the emission level of the EUT in peak mode was 3 dB lower than the limit specified, then testing will be stopped and peak values of EUT will be reported, otherwise, the emissions which do not have 3 dB margin will be repeated one by one using the quasi-peak method and reported.
- For testing above 1GHz, the emission level of the EUT in peak mode was 20dB lower than average limit (that means the emission level in peak mode also complies with the limit in average mode), then testing will be stopped and peak values of EUT will be reported, otherwise, the emissions will be measured in average mode again and reported.
- "Cone of radiation" has been considered to be 3dB bandwidth of the measurement antenna.



6.3 Typical Test Setup

Below 30MHz test setup

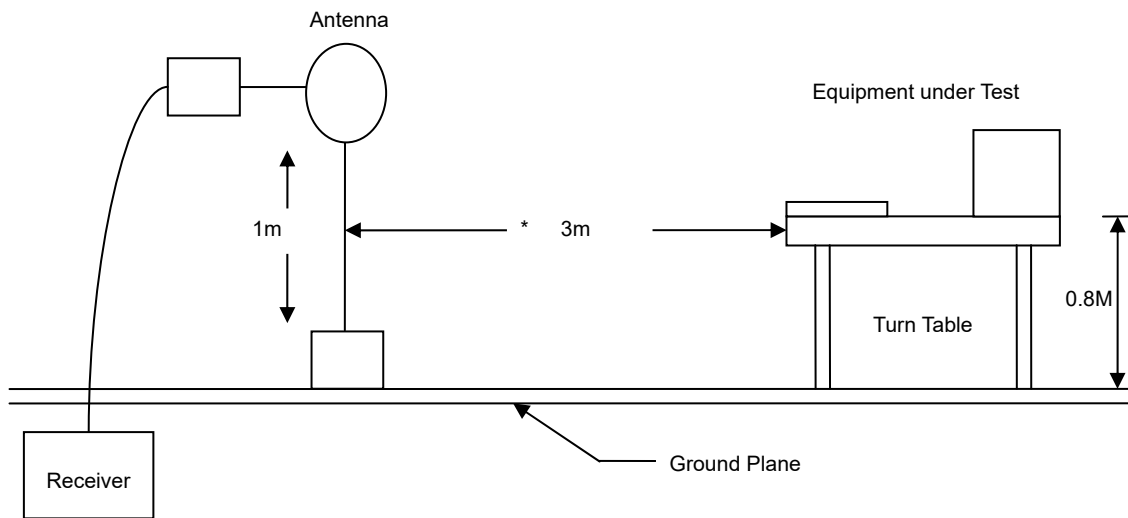

30MHz- 1GHz Test Setup

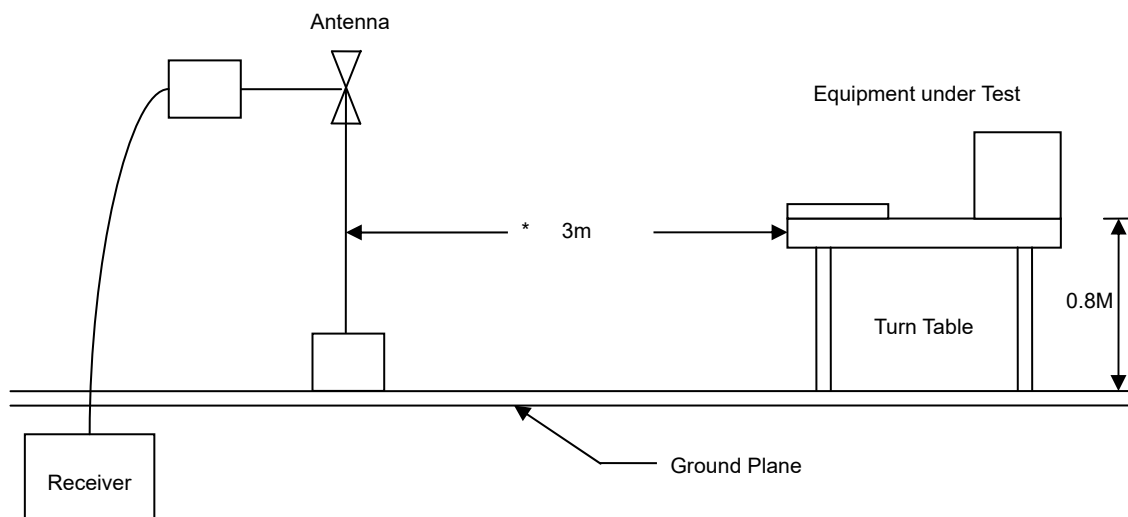

Above 1GHz Test Setup

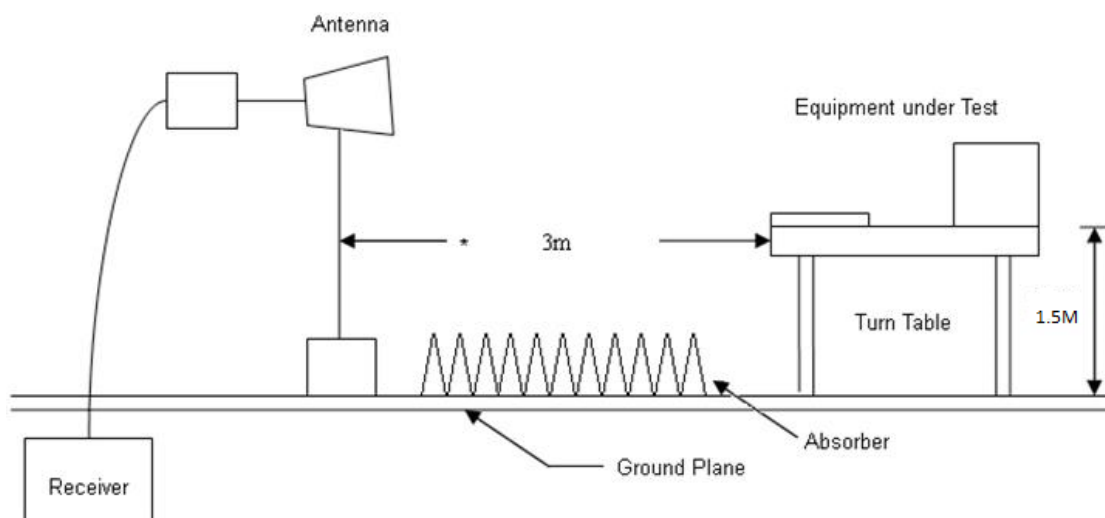



6.4 Test Result and Data (9kHz ~ 30MHz)

The 9kHz - 30MHz spurious emission is under limit 20dB more.

6.5 Test Result and Data (30MHz ~ 1GHz)

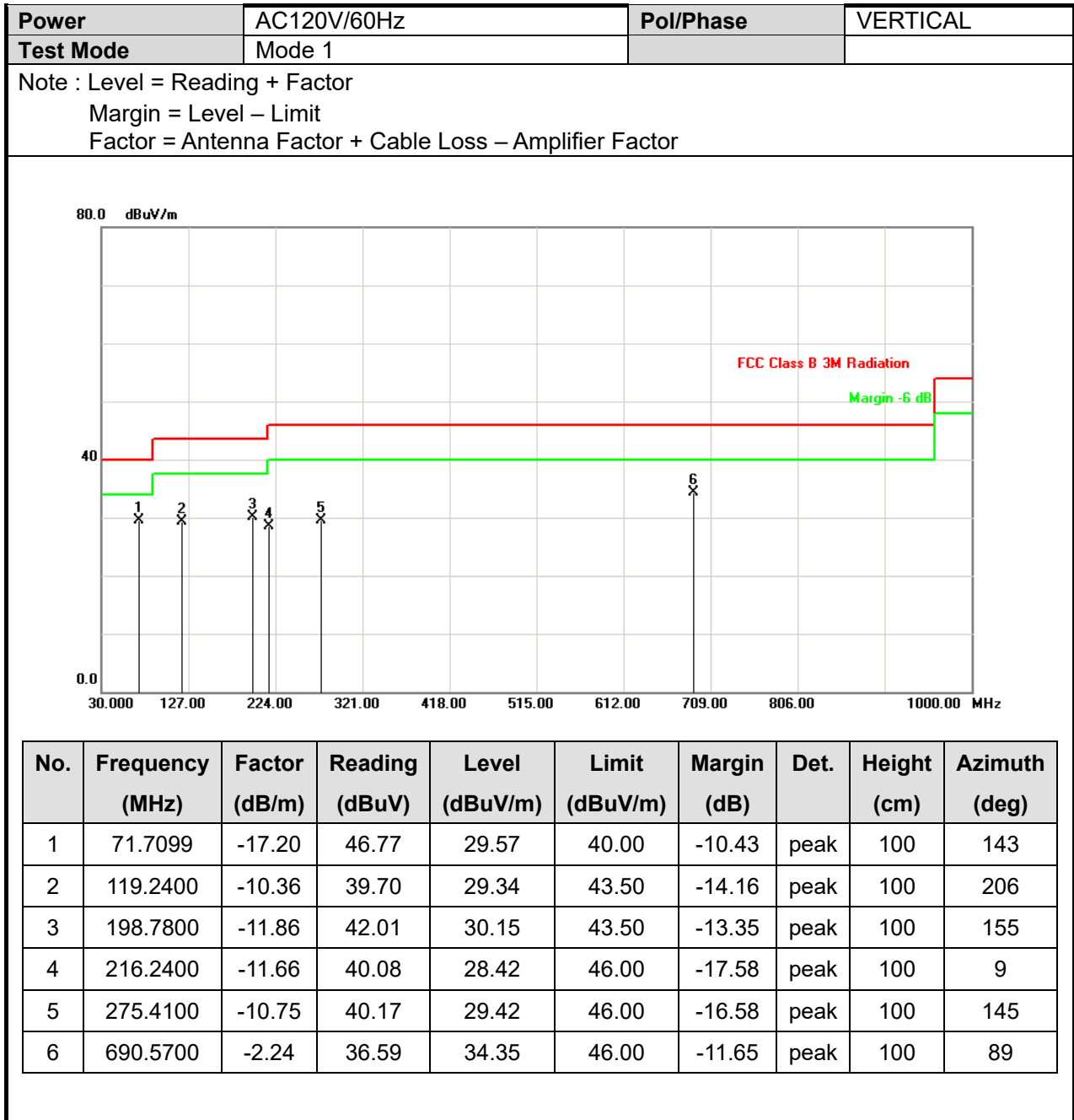

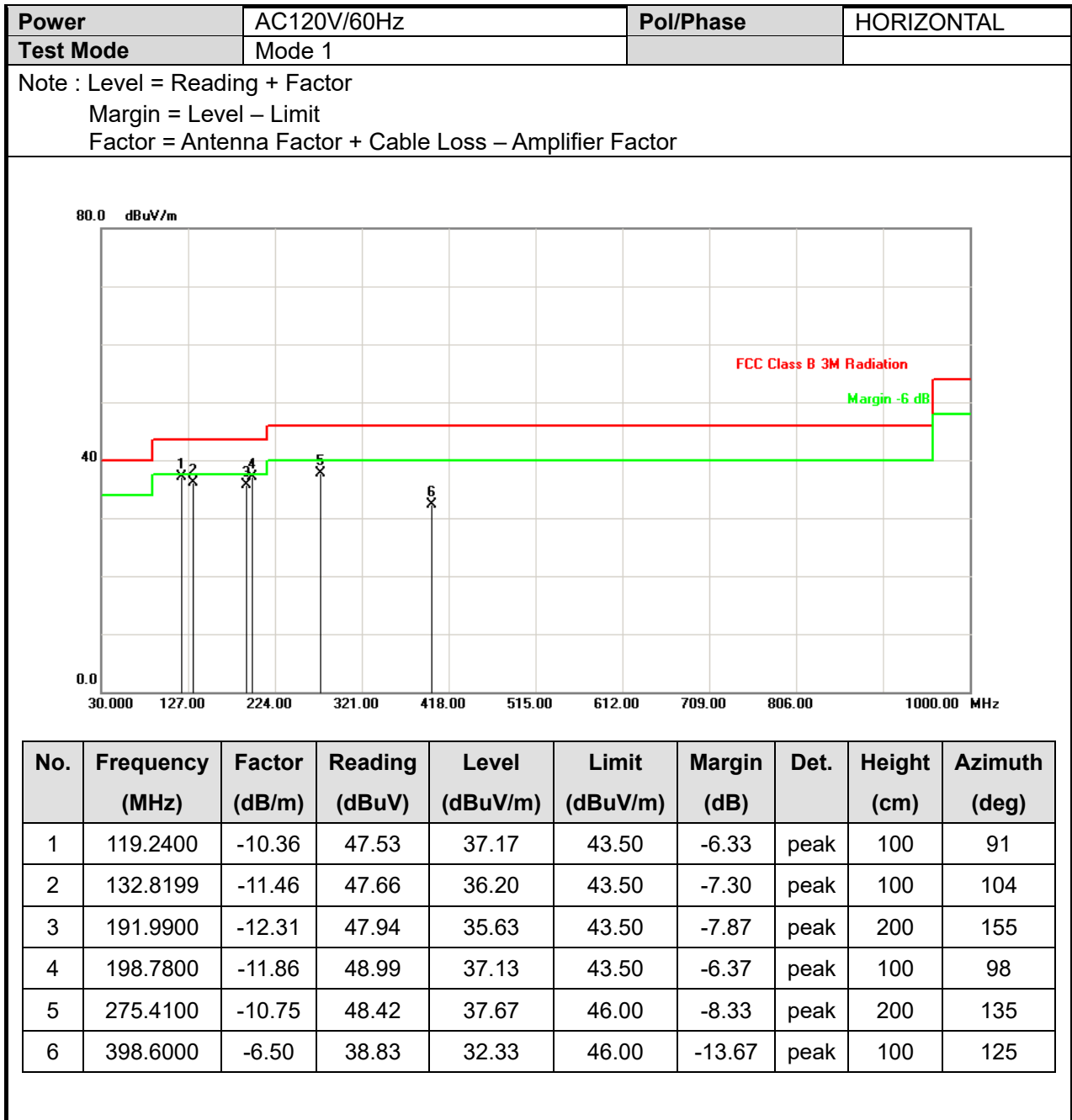



6.6 Test Result and Data (1GHz ~ 25GHz)

Power	DC 3.7V	Pol/Phase	VERTICAL
Test Mode	Mode 1, CH 00	Operation mode	TX

Note : Level = Reading + Factor
 Margin = Level – Limit
 Factor = Antenna Factor + Cable Loss – Amplifier Factor
 The 18000MHz - 25000MHz spurious emission is under limit 20dB more.

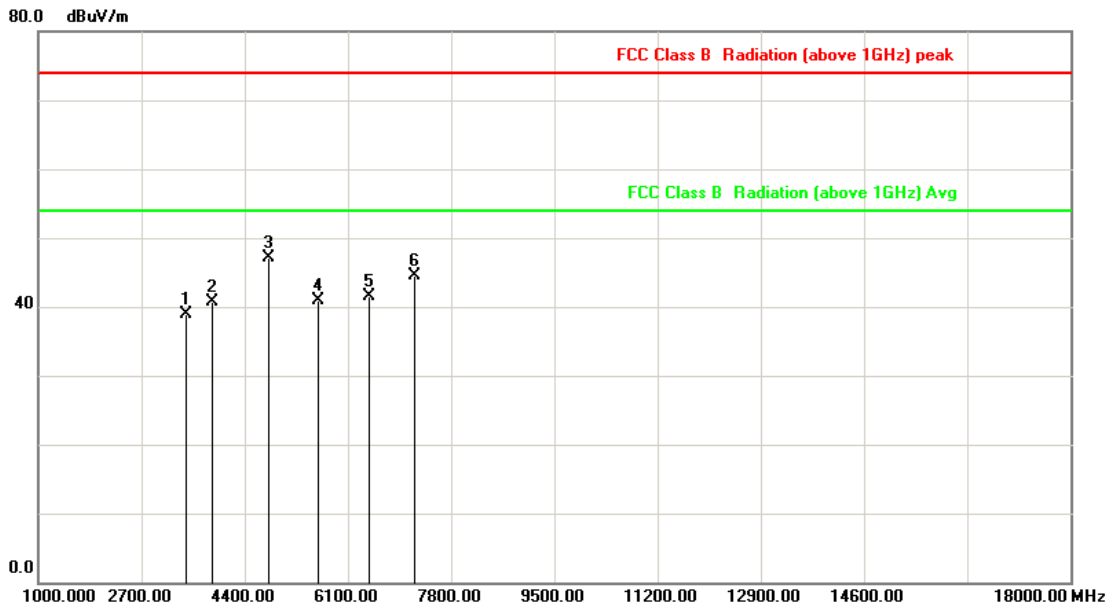

No.	Frequency (MHz)	Factor (dB/m)	Reading (dBuV)	Level (dBuV/m)	Limit (dBuV/m)	Margin (dB)	Det.
1	3436.667	-3.93	42.74	38.81	74.00	-35.19	peak
2	3861.667	-2.36	43.13	40.77	74.00	-33.23	peak
3	4804.000	1.23	45.91	47.14	74.00	-26.86	peak
4	5618.333	2.31	38.58	40.89	74.00	-33.11	peak
5	6440.000	3.44	38.11	41.55	74.00	-32.45	peak
6	7206.000	5.88	38.60	44.48	74.00	-29.52	peak



Power	DC 3.7V	Pol/Phase	HORIZONTAL
Test Mode	Mode 1, CH 00	Operation mode	TX

Note : Level = Reading + Factor
 Margin = Level – Limit
 Factor = Antenna Factor + Cable Loss – Amplifier Factor
 The 18000MHz - 25000MHz spurious emission is under limit 20dB more.

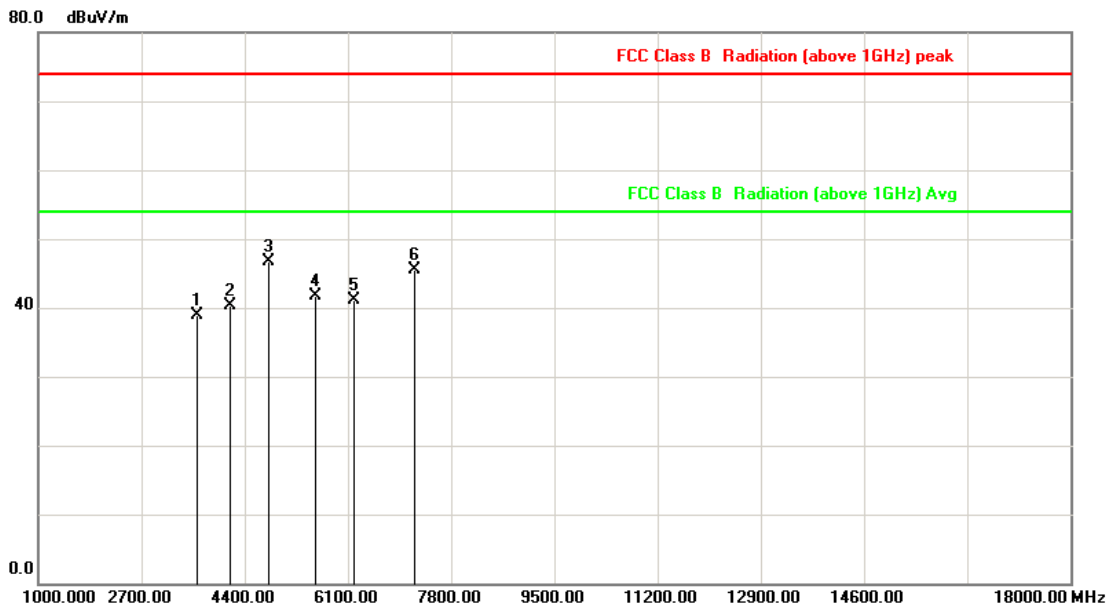

No.	Frequency (MHz)	Factor (dB/m)	Reading (dBuV)	Level (dBuV/m)	Limit (dBuV/m)	Margin (dB)	Det.
1	3606.667	-3.24	42.19	38.95	74.00	-35.05	peak
2	4173.333	-1.01	41.23	40.22	74.00	-33.78	peak
3	4804.000	1.23	45.52	46.75	74.00	-27.25	peak
4	5561.667	2.17	39.52	41.69	74.00	-32.31	peak
5	6213.333	3.35	37.85	41.20	74.00	-32.80	peak
6	7206.000	5.88	39.63	45.51	74.00	-28.49	peak



Power	DC 3.7V	Pol/Phase	VERTICAL
Test Mode	Mode 1, CH 19	Operation mode	TX

Note : Level = Reading + Factor
Margin = Level – Limit
Factor = Antenna Factor + Cable Loss – Amplifier Factor
The 18000MHz - 25000MHz spurious emission is under limit 20dB more.

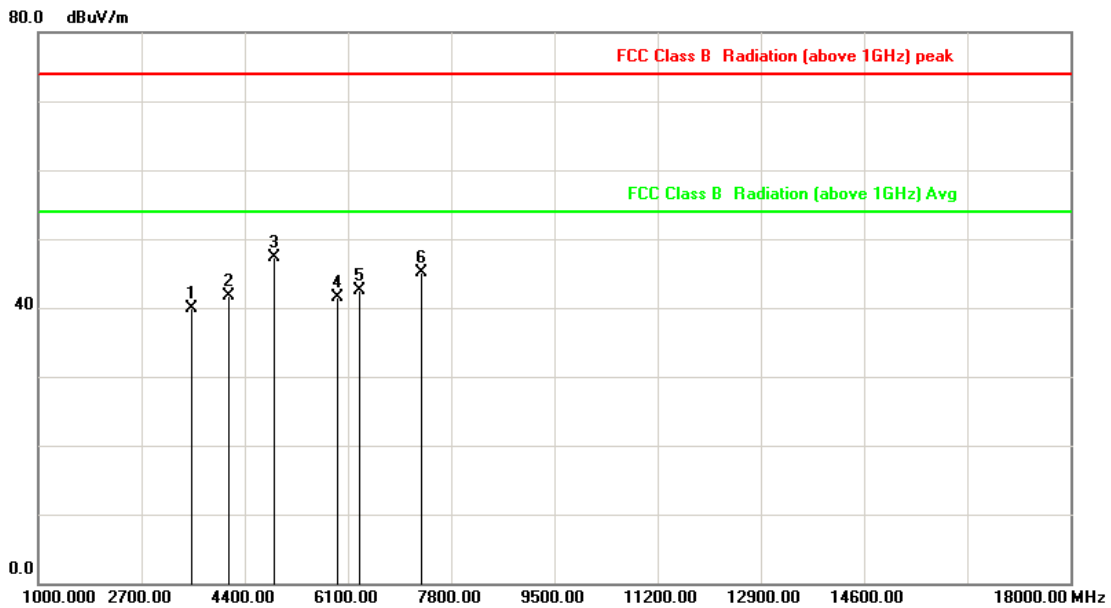

No.	Frequency (MHz)	Factor (dB/m)	Reading (dBuV)	Level (dBuV/m)	Limit (dBuV/m)	Margin (dB)	Det.
1	3521.667	-3.53	43.48	39.95	74.00	-34.05	peak
2	4145.000	-1.15	42.78	41.63	74.00	-32.37	peak
3	4880.000	1.37	45.96	47.33	74.00	-26.67	peak
4	5930.000	3.09	38.44	41.53	74.00	-32.47	peak
5	6298.333	3.38	39.16	42.54	74.00	-31.46	peak
6	7320.000	6.33	38.76	45.09	74.00	-28.91	peak



Power	DC 3.7V	Pol/Phase	HORIZONTAL
Test Mode	Mode 1, CH 19	Operation mode	TX

Note : Level = Reading + Factor
 Margin = Level – Limit
 Factor = Antenna Factor + Cable Loss – Amplifier Factor
 The 18000MHz - 25000MHz spurious emission is under limit 20dB more.

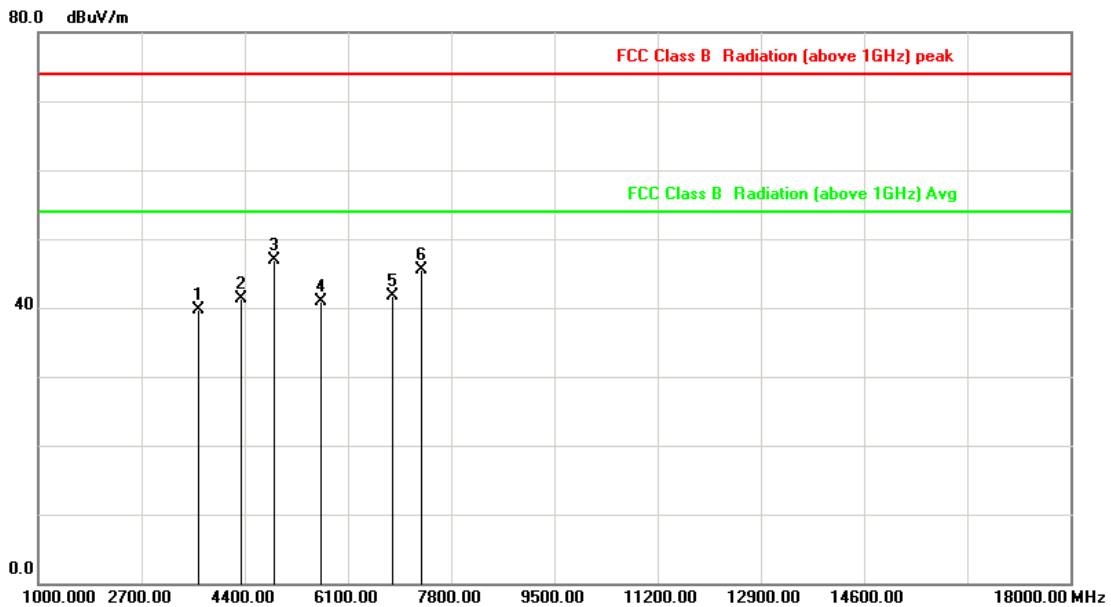

No.	Frequency (MHz)	Factor (dB/m)	Reading (dBuV)	Level (dBuV/m)	Limit (dBuV/m)	Margin (dB)	Det.
1	3635.000	-3.14	42.80	39.66	74.00	-34.34	peak
2	4343.333	-0.14	41.48	41.34	74.00	-32.66	peak
3	4880.000	1.37	45.62	46.99	74.00	-27.01	peak
4	5646.667	2.38	38.62	41.00	74.00	-33.00	peak
5	6836.667	4.55	37.09	41.64	74.00	-32.36	peak
6	7320.000	6.33	39.21	45.54	74.00	-28.46	peak



Power	DC 3.7V	Pol/Phase	VERTICAL
Test Mode	Mode 1, CH 39	Operation mode	TX

Note : Level = Reading + Factor
Margin = Level – Limit
Factor = Antenna Factor + Cable Loss – Amplifier Factor
The 18000MHz - 25000MHz spurious emission is under limit 20dB more.

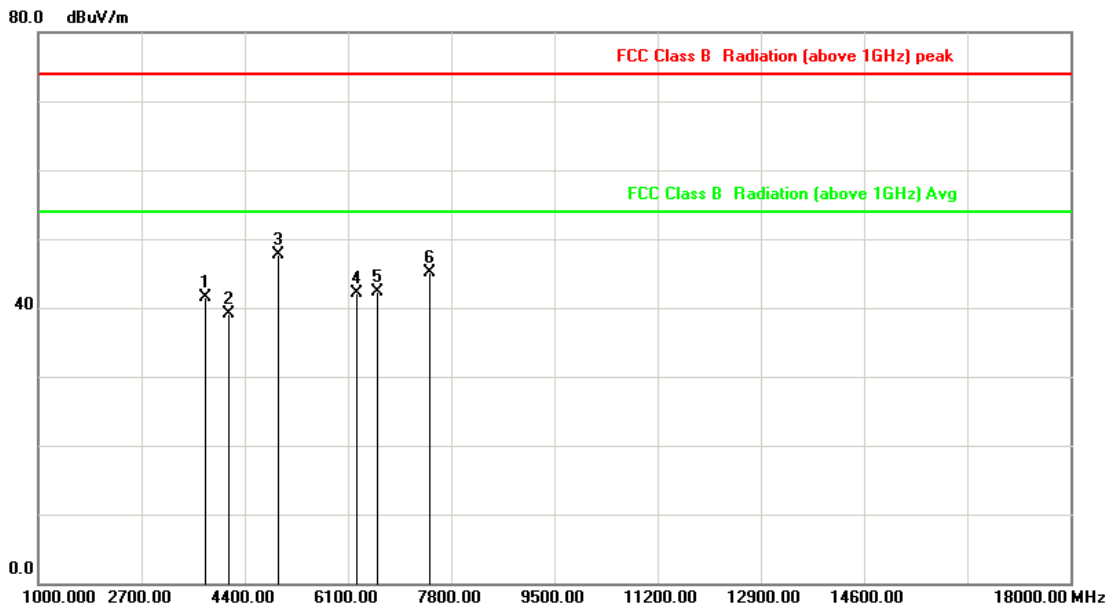

No.	Frequency (MHz)	Factor (dB/m)	Reading (dBuV)	Level (dBuV/m)	Limit (dBuV/m)	Margin (dB)	Det.
1	3748.333	-2.75	44.24	41.49	74.00	-32.51	peak
2	4145.000	-1.15	40.28	39.13	74.00	-34.87	peak
3	4960.000	1.52	46.21	47.73	74.00	-26.27	peak
4	6241.667	3.36	38.83	42.19	74.00	-31.81	peak
5	6581.667	3.72	38.55	42.27	74.00	-31.73	peak
6	7440.000	6.80	38.22	45.02	74.00	-28.98	peak



Power	DC 3.7V	Pol/Phase	HORIZONTAL
Test Mode	Mode 1, CH 39	Operation mode	TX

Note : Level = Reading + Factor
 Margin = Level – Limit
 Factor = Antenna Factor + Cable Loss – Amplifier Factor
 The 18000MHz - 25000MHz spurious emission is under limit 20dB more.

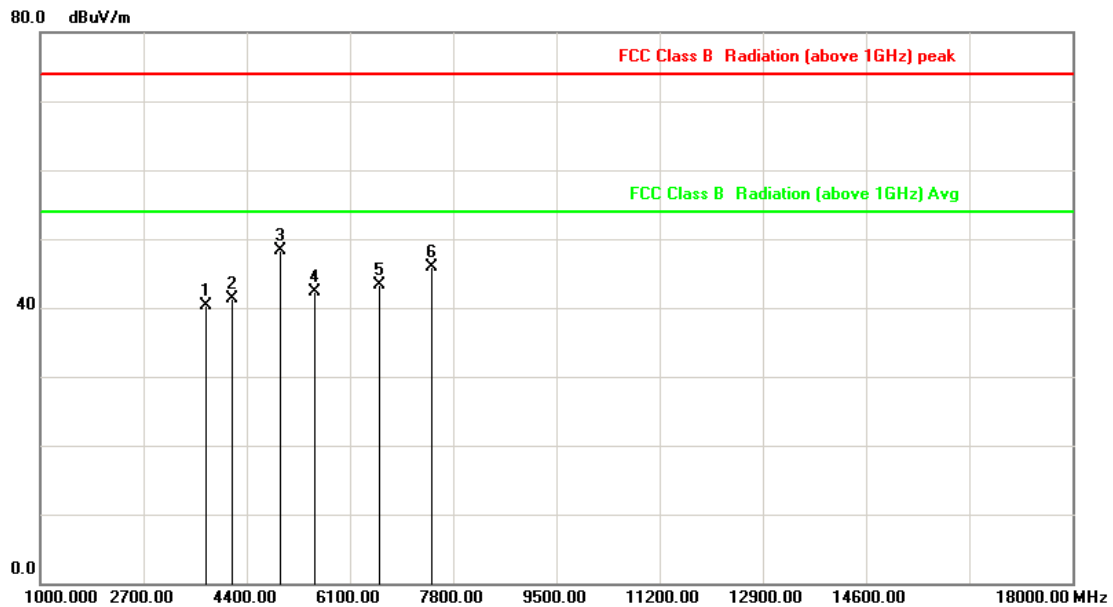

No.	Frequency (MHz)	Factor (dB/m)	Reading (dBuV)	Level (dBuV/m)	Limit (dBuV/m)	Margin (dB)	Det.
1	3720.000	-2.85	43.06	40.21	74.00	-33.79	peak
2	4173.333	-1.01	42.23	41.22	74.00	-32.78	peak
3	4960.000	1.52	46.75	48.27	74.00	-25.73	peak
4	5533.333	2.10	40.12	42.22	74.00	-31.78	peak
5	6581.667	3.72	39.60	43.32	74.00	-30.68	peak
6	7440.000	6.80	39.17	45.97	74.00	-28.03	peak



6.7 Restricted Bands of Operation

Only spurious emissions are permitted in any of the frequency bands listed below:

MHz	MHz	MHz	GHz
0.09000 – 0.11000	16.42000 – 16.42300	399.9 – 410.0	4.500 – 5.250
0.49500 – 0.505**	16.69475 – 16.69525	608.0 – 614.0	5.350 – 5.460
2.17350 – 2.19050	16.80425 – 16.80475	960.0 – 1240.0	7.250 – 7.750
4.12500 – 4.12800	25.50000 – 25.67000	1300.0 – 1427.0	8.025 – 8.500
4.17725 – 4.17775	37.50000 – 38.25000	1435.0 – 1626.5	9.000 – 9.200
4.20725 – 4.20775	73.00000 – 74.60000	1645.5 – 1646.5	9.300 – 9.500
6.21500 – 6.21800	74.80000 – 75.20000	1660.0 – 1710.0	10.600 – 12.700
6.26775 – 6.26825	108.00000 – 121.94000	1718.8 – 1722.2	13.250 – 13.400
6.31175 – 6.31225	123.00000 – 138.00000	2200.0 – 2300.0	14.470 – 14.500
8.29100 – 8.29400	149.90000 – 150.05000	2310.0 – 2390.0	15.350 – 16.200
8.36200 – 8.36600	156.52475 – 156.52525	2483.5 – 2500.0	17.700 – 21.400
8.37625 – 8.38675	156.70000 – 156.90000	2655.0 – 2900.0	22.010 – 23.120
8.41425 – 8.41475	162.01250 – 167.17000	3260.0 – 3267.0	23.600 – 24.000
12.29000 – 12.29300	167.72000 – 173.20000	3332.0 – 3339.0	31.200 – 31.800
12.51975 – 12.52025	240.00000 – 285.00000	3345.8 – 3358.0	36.430 – 36.500
12.57675 – 12.57725	322.00000 – 335.40000	3600.0 – 4400.0	Above 38.6
13.36000 – 13.41000			

** : Until February 1, 1999, this restricted band shall be 0.490-0.510 MHz



7. Test of Spurious Emission (Conducted)

7.1 Test Limit

Below -20dB of the highest emission level of operating band (In 100 kHz Resolution Bandwidth)

7.2 Test Procedure

- a. The transmitter output was connected to the spectrum analyzer via a low loss cable.
- b. Set RBW of spectrum analyzer to 100 KHz and VBW of spectrum analyzer to 300 KHz with convenient frequency span including 100 KHz bandwidth from band edge.
- c. Peak conducted output power measured within any 100 kHz outside the authorized frequency band shall be attenuated by at least 20dB relative to the maximum measured in-band peak PSD level.
- d. The band edges was measured and recorded.

7.3 Test Setup Layout

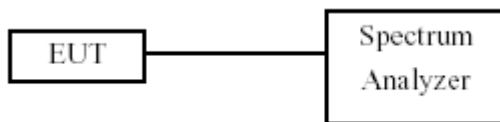

7.4 Test Result and Data

Note: Test plots refer to the following pages.



Modulation Type: GFSK
CH00

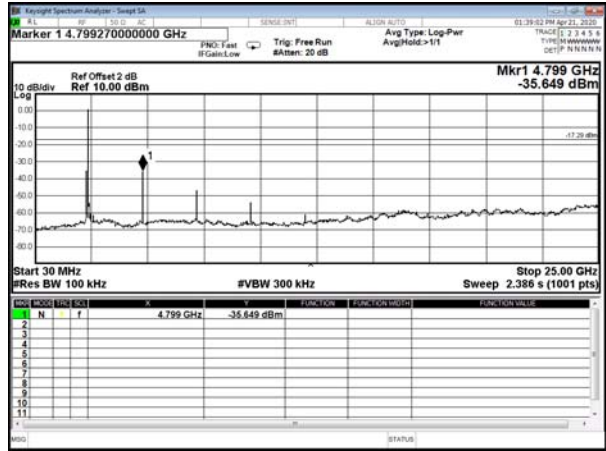
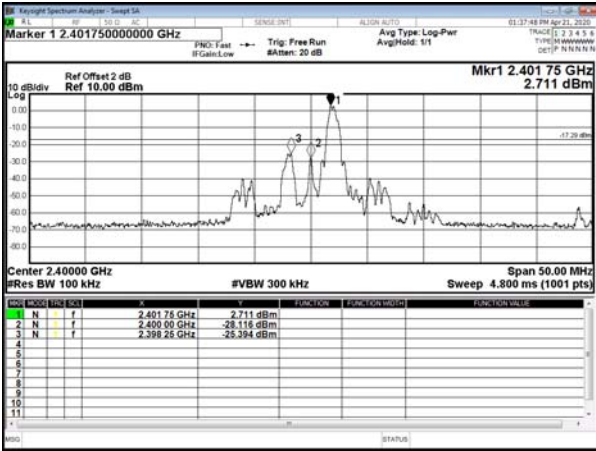

Modulation Type: GFSK
CH19

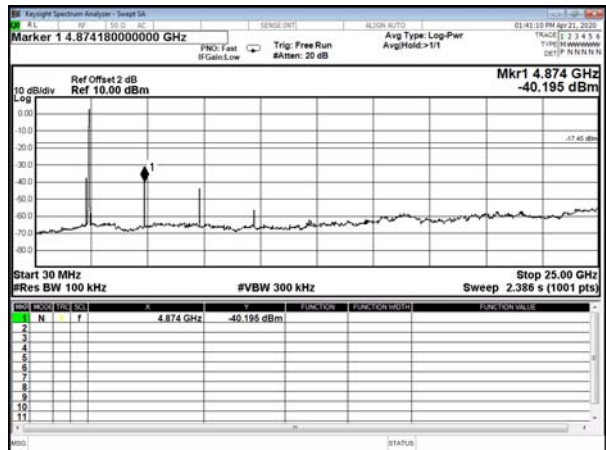
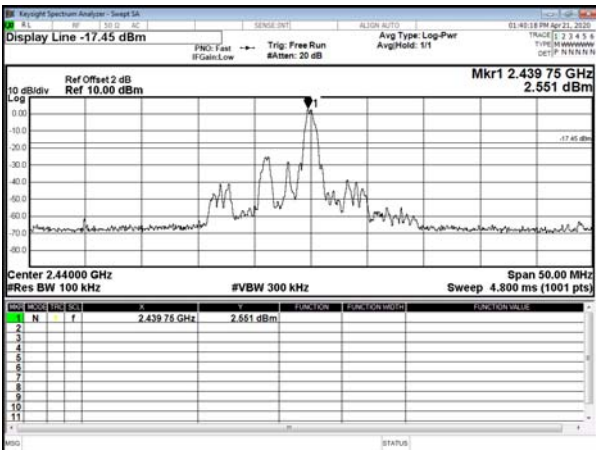

Modulation Type: GFSK
CH39

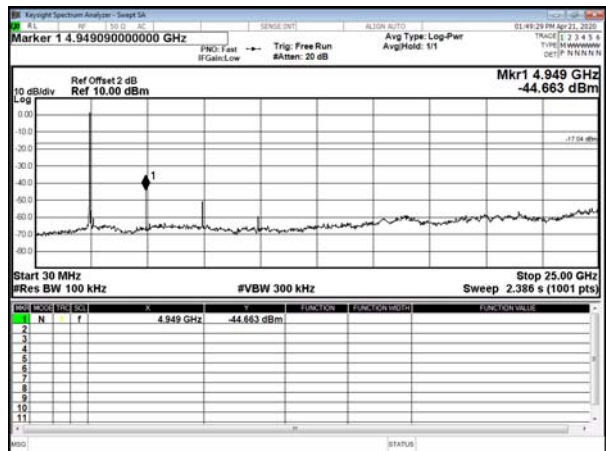
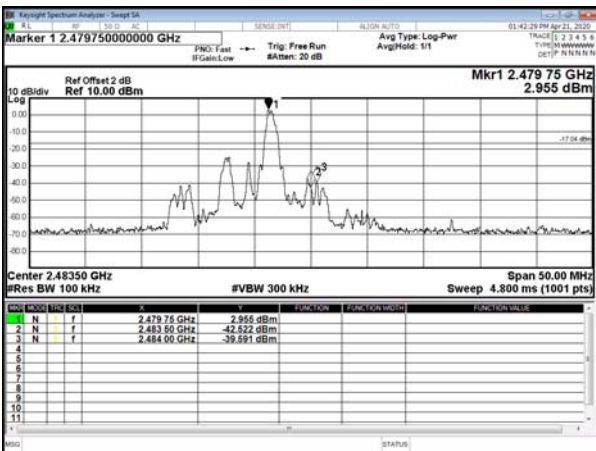



8. 6dB Bandwidth Measurement Data

8.1 Test Limit

The minimum of 6dB Bandwidth Measurement is 0.5 MHz.

8.2 Test Procedures

- a. The transmitter output was connected to the spectrum analyzer.
- b. Set RBW of spectrum analyzer to 1~5% of the emission bandwidth and VBW \geq 3x RBW.
- c. The 6 dB bandwidth is defined as the total spectrum the power of which is higher than peak power minus 6 dB.
- d. The 6dB Bandwidth was measured and recorded.

8.3 Test Setup Layout

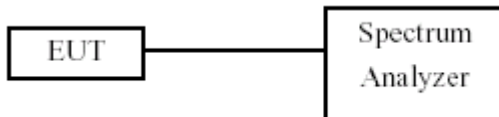

8.4 Test Result and Data

Modulation Type	Channel	Frequency (MHz)	6dB Bandwidth (KHz)	Limit (KHz)
GFSK	00	2402	504	500
	19	2440	503	500
	39	2480	505	500



Modulation Standard: GFSK (1Mbps)
Channel: 00

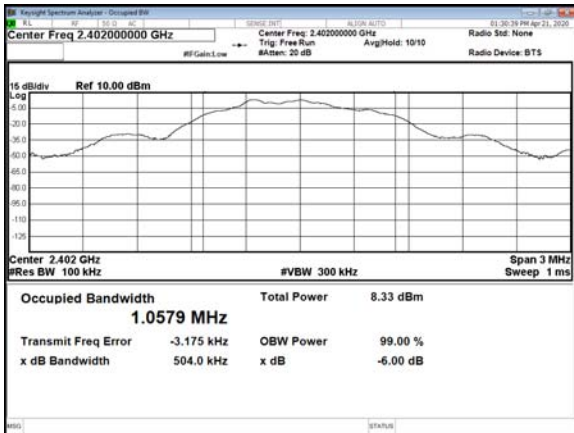

Modulation Standard: GFSK (1Mbps)
Channel: 19

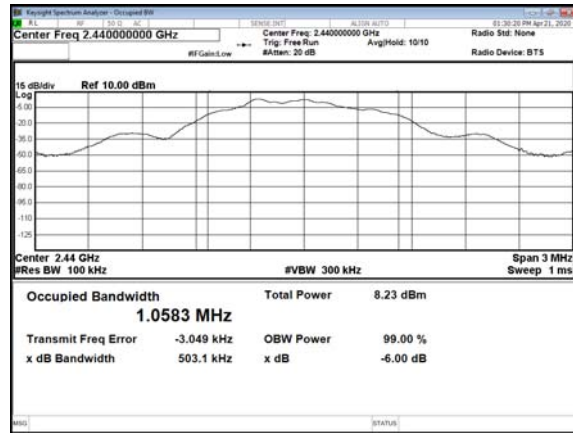

Modulation Standard: GFSK (1Mbps)
Channel: 39

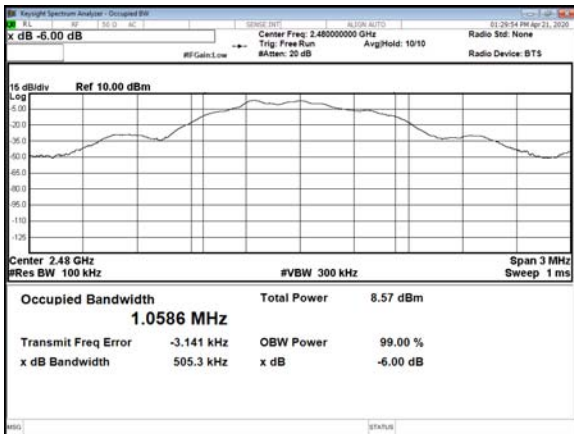



9. Maximum Peak and Average Output Power

9.1 Test Limit

The Maximum Peak Output Power Measurement is 30dBm.

9.2 Test Procedures

The antenna port (RF output) of the EUT was connected to the input (RF input) of a power meter. Power was read directly from the meter and cable loss connection was added to the reading to obtain power at the EUT antenna terminal. The EUT Output Power was set to maximum to produce the worse case test result.

9.3 Test Setup Layout

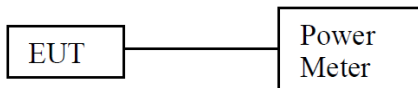

9.4 Test Result and Data

Modulation Standard	Channel	Frequency (MHz)	Power Output (dBm)	Peak Power Output (mW)
GFSK	00	2402	4.07	2.553
	19	2440	3.84	2.421
	39	2480	4.19	2.624



10. Power Spectral Density

10.1 Test Limit

The Maximum of Power Spectral Density Measurement is 8dBm.

10.2 Test Procedures

- a. The transmitter output was connected to spectrum analyzer.
- b. The spectrum analyzer's resolution bandwidth were set at 3KHz RBW and 10KHz VBW as that of the fundamental frequency. Set the sweep time=auto couple.
- c. The power spectral density was measured and recorded.

10.3 Test Setup Layout

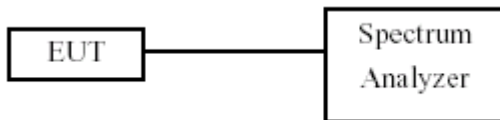



10.4 Test Result and Data

Modulation Standard	Channel	Frequency (MHz)	Maximum Power Density of 3 kHz Bandwidth (dBm)	Limit
GFSK	00	2402	-15.587	8.00
	19	2440	-15.663	8.00
	39	2480	-15.330	8.00

Modulation Standard: GFSK (1Mbps)
Channel: 00



Modulation Standard: GFSK (1Mbps)
Channel: 19



Modulation Standard: GFSK (1Mbps)
Channel: 39



----- End of the report -----