



# **Compology Camera (R13/R13S) Installation Guide (Screw Mount & Tape Mount System)**



# The Basics

**NOTICE:**

*This device contains licence-exempt transmitter(s)/receiver(s) that comply with Innovation, Science and Economic Development Canada's licence-exempt RSS(s).*

*Operation is subject to the following two conditions:*

- 1. this device may not cause harmful interference.*
- 2. this device must accept any interference, including interference that may cause undesired operation of the device.*

*Le présent appareil est conforme aux CNR d'Industrie Canada applicables aux appareils radio exempts de licence. L'exploitation est autorisée aux deux conditions suivantes:*

- (1) l'appareil ne doit pas produire de brouillage, et*
- (2) l'appareil doit accepter tout brouillage radioélectrique subi, même si le brouillage est susceptible d'en compromettre le fonctionnement.*

**NOTICE:**

*Changes or modifications made to this equipment not expressly approved by Compology may void the FCC authorization to operate this equipment.*

As in FCC / ISED RSS-102 standards, to comply with FCC RF exposure requirements for mobile transmitting devices, this device shall be installed to provide a separation distance of 20cm (~8 inches) or more from all persons  
And the transmitters on this device do not transmit simultaneously.

# Compology Conduct

As a Compology Technician, it is important to be a positive representative of Compology and the companies we work with. The following are rules you must follow when performing any work on behalf of Compology

## Attire, grooming

- Look professional (no torn, stained clothing)
- Wear your Compology logo'd apparel if appropriate

## Identification

- Carry personal identification
- Carry Compology identification/Business cards (if provided)
- Wear your Compology high vis vest and hard hat

## Behavior

- Do's
  - Be polite & friendly
  - Smile!
  - Practice safety!
- Donts
  - Foul language
  - Pressure customer/insist to do install
  - Avoid interaction with customers
  - Use customer facilities

# On-site Behavior

## **Customer objections**

- Never argue with customers
- If an individual has an objection to your being there or having a camera installed, give them contact information for the project point of contact and leave the site
  - Maintain a polite & positive attitude
  - Contact Compology and let them know you were unable to complete the install, the circumstances and whom you dealt with on location

## **Unable to install & reporting**

- Immediately notify Compology & Customer if a business/individual shows objections to having a camera installed on their container.

## **Site tidiness and clean up**

- Leave No Trace policy: Pick up any debris created during installs (empty boxes, drill bits, etc).
- No loitering on site, leave promptly

## **Zero tolerance items**

- Theft
- Smoking
- Alcohol or drug use

# On-site Behavior (continued)

## Complaints

As a Technician, you will visit businesses and residences to service Compology equipment, and there can be times when you receive a complaints from them.

- A complaint is any of the following scenarios:
  - Does not want sensor installed/did not approve installation
  - Was not notified ahead of time
  - Starts asking questions about issues with their waste services

## Responses

- If a complaint is related to sensor installation, offer to come back another time after they have spoken with the Hauler. Provide letter of authorization and contact information
- If a complaint is related to hauler service, provide contact information for Hauler representative and verify that they are comfortable with installation.

## Reporting

- Report all complaints to the Compology project manager same day.
  - Information needed when giving report:
    - Business/Location Name
    - Address
    - Date & Time
    - Name of individual making complaint
    - Any other useful information
  - Compology main number: 415-848-9169

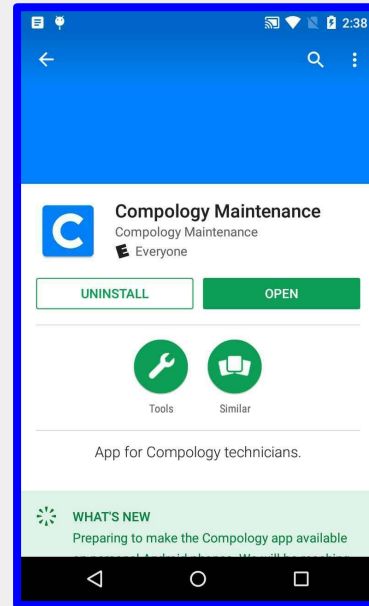

# Compology Tech App

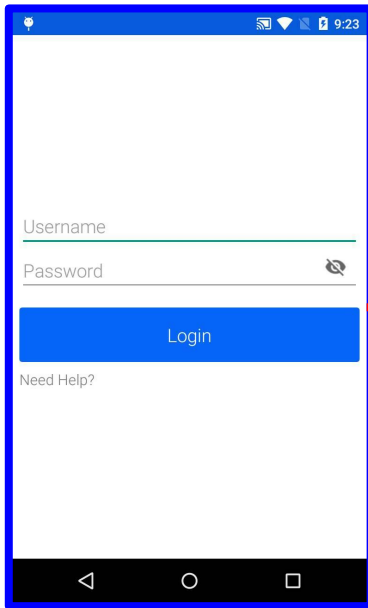

**1. Login**

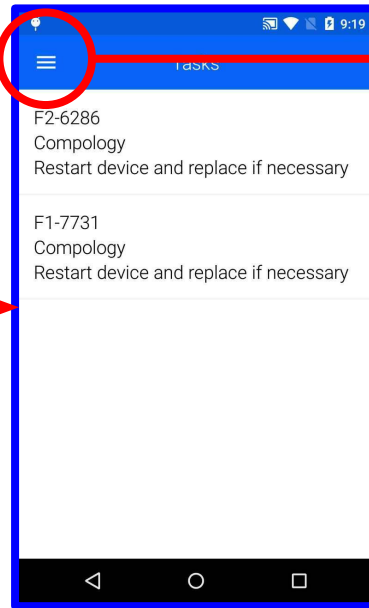

**2. Click Icon**

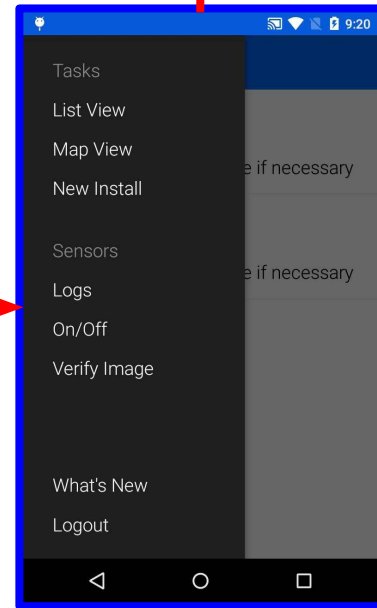

## Main Menu

**3. Main Menu**

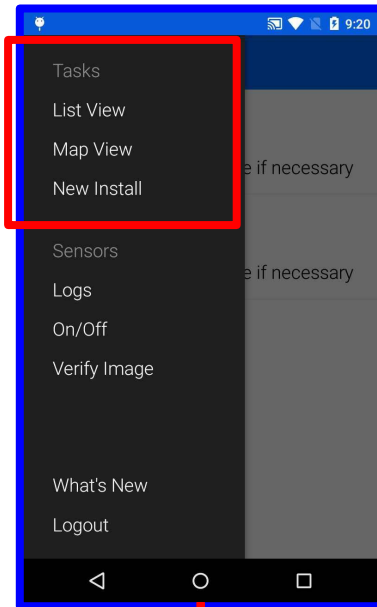

# Tasks

*Start here to complete maintenance tasks or installs*

- **List View** – View of maintenance tasks in a list
- **Map View** – View of maintenance tasks on a map
- **New Install** – Create a new bin and assign a sensor

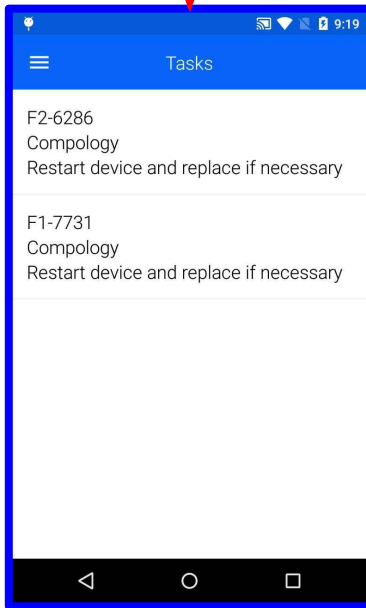

**List View**

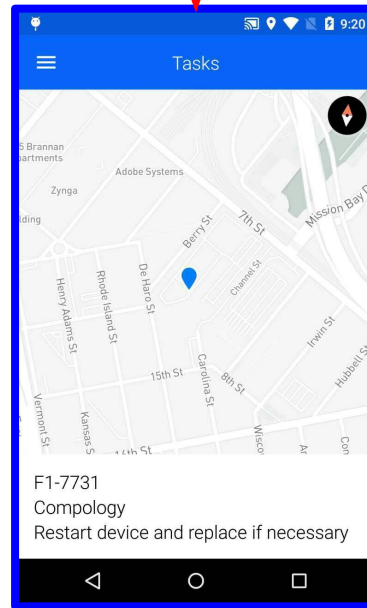

**Map View**

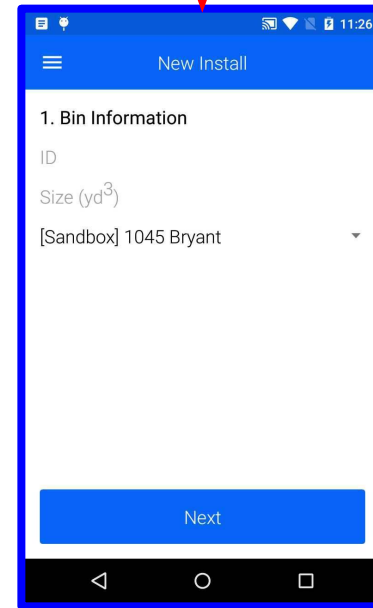

**New Install**



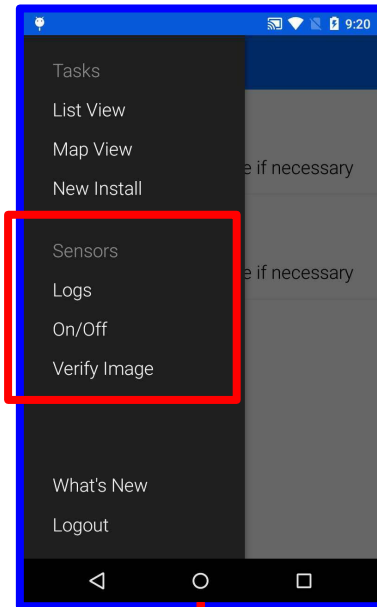

## Sensor Tools

*Tap phone to sensor to interact and get info*

- **Logs** – View diagnostic info on a sensor
- **On/Off** – Turn sensor on or off
- **Verify Image** – See the latest image from a sensor

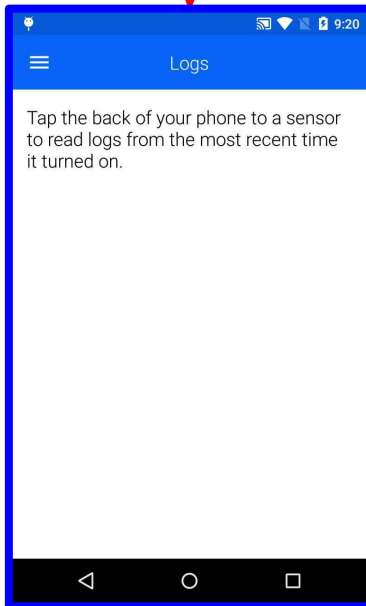

**Logs**

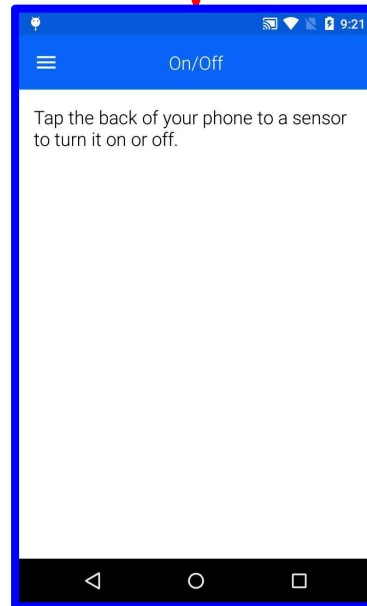

**On/Off**

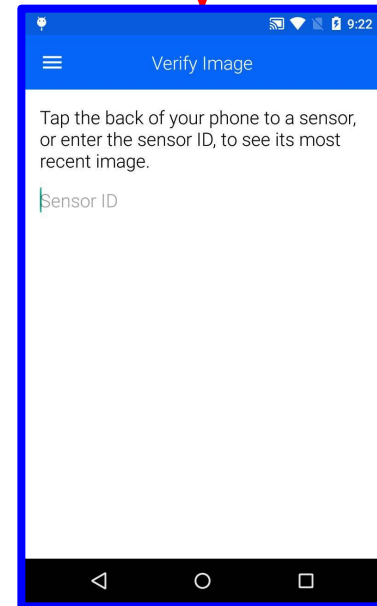

**Verify Image**

# New Install

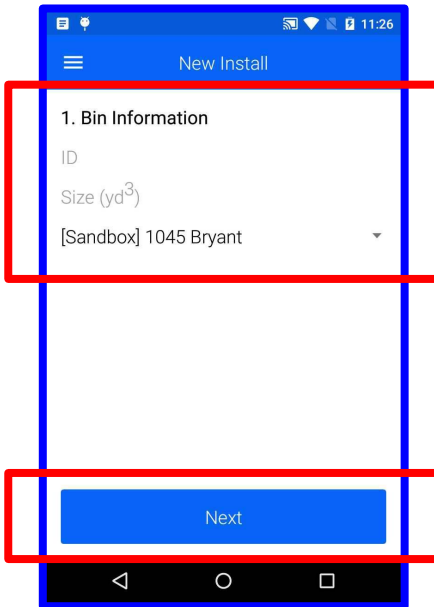

## 1. ENTER BIN INFORMATION

- **ID** – Enter number/name on outside of bin
- **Size** – Enter the size of bin in cubic yards
- **Organization** – Select the organization for this bin
- **Content** – Select the type of material in container

**CLICK & HOLD**

**IMPORTANT:** You will need to select an organization if you are assigned to multiple. Make sure you select the correct one!

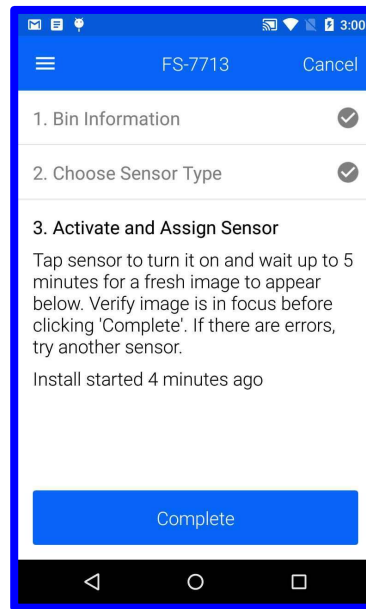

**TAP PHONE TO  
SENSOR TO ACTIVATE**

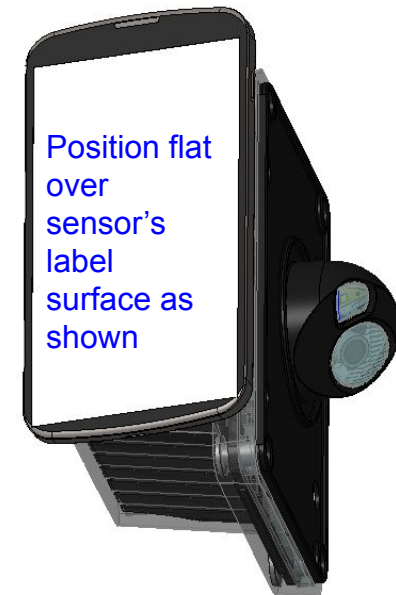

ID of the sensor waiting to be assigned to the bin. Tapping any sensor will turn on or off that sensor and change the ID

**4. VERIFY GREEN IMAGE & NO ERRORS**

**5. COMPLETE**

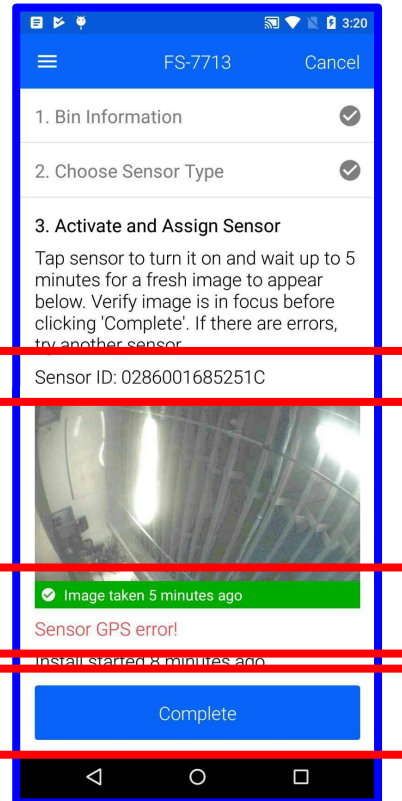

**If new image does not appear within 15 minutes:**

1. Restart the current sensor by tapping sensor to turn off and then on
2. Wait for new image
3. If no new image appears, try new sensor

**IMPORTANT:** Do not install sensor if new image does not appear

**If you see 'Sensor GPS Error':**

1. Move to a location where you can see the sky,
2. Restart current sensor and wait for new image
3. If GPS error remains, try new sensor

**IMPORTANT:** Do not install sensor with GPS error.

# Turning Sensor On/Off

**On/Off** will be used to turn a sensor on or off when not in a task. You can use it to restart a sensor you want to check.

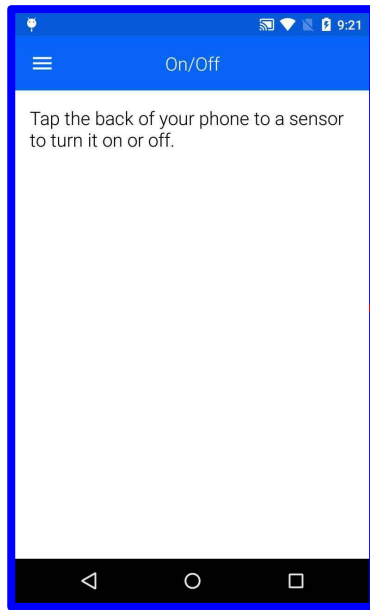

### TURNING ON

Wait 5-10s, blue light will blink slowly 5X, and then flash a blue light every 2s during startup sequence

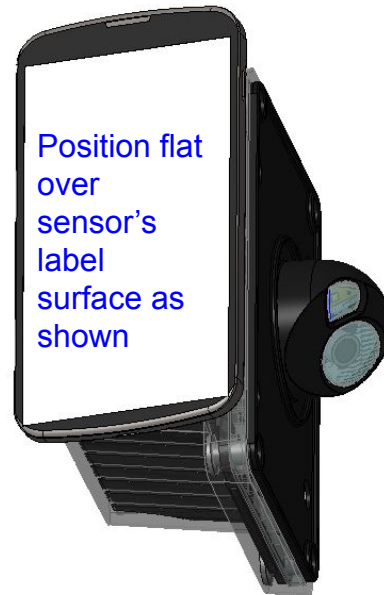
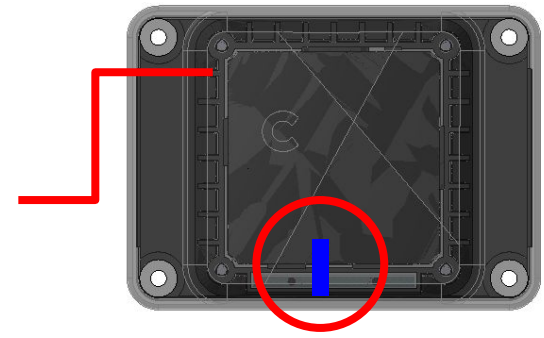

“DING!”

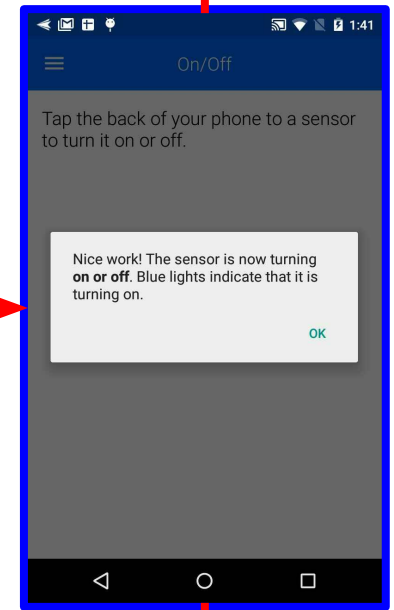

**IMPORTANT:** Make sure any sensors in your bag or inventory are OFF and all sensors you are installing into bins are ON. Pay careful attention to the indicator lights.

### TURNING OFF

Immediately, yellow light will blink 10X very quickly and then turn off

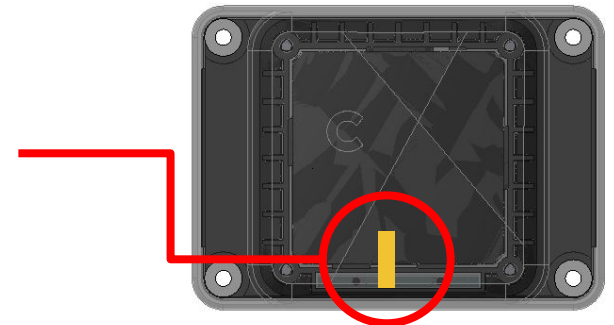

# Checking Sensor Logs

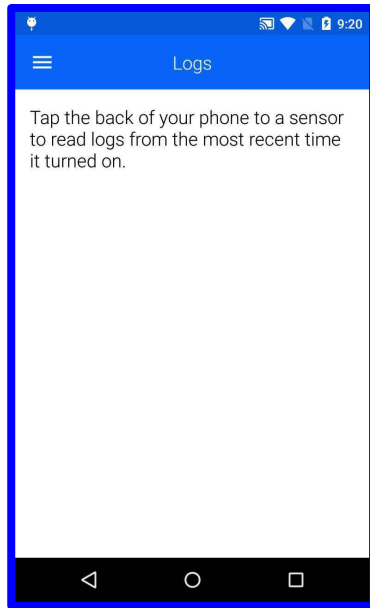

**“DING!”**

**Green = Good**  
**Red = Error**



**Logs** should be used to identify root issues when a sensor is not uploading an image. It can only be taken after a sensor has gone through its startup sequence and the indicator light is no longer flashing.

### Most common errors:

- **MODEM\_CONNECT** (cannot get cell signal). In this situation, restart sensor and try again before replacing
- **GPS\_LOCK** (cannot get GPS signal). Move to a location where you can see the sky and try again before replacing sensor
- **SYSTEM** will be an error if anything has failed



# Verify Image

**Verify Image** should be used after a sensor is restarted to check to see if an image was uploaded successfully

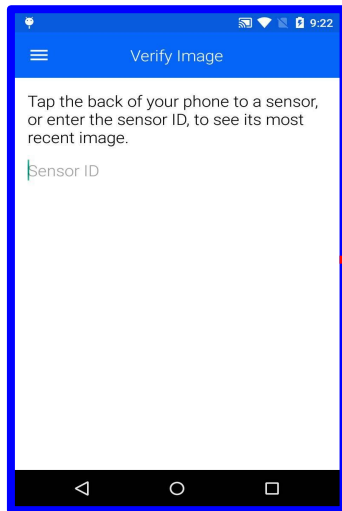

“DING!”



**SENSOR ID**

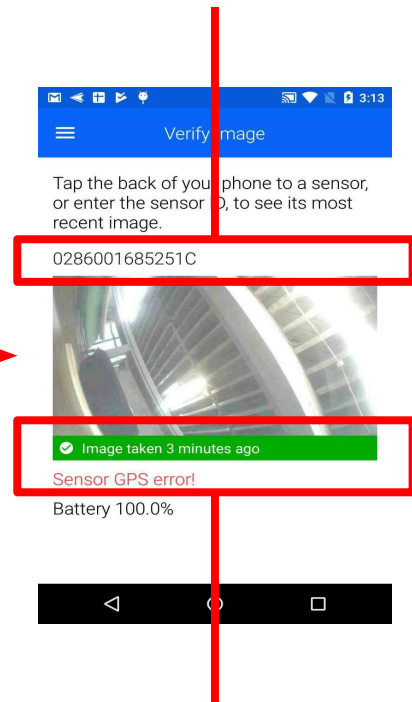

**VERIFY GREEN IMAGE & NO ERRORS**

# Physical Install Overview

# Safety

Safety is extremely important. Always wear proper protective equipment required on job sites. The links below are OSHA regulations on proper ladder and power tool use and safety.

## Ladders:

<https://www.osha.gov/laws-regs/regulations/standardnumber/1926/1926.1053>

## Power Tools:

<https://www.osha.gov/laws-regs/regulations/standardnumber/1926/1926.302>

## Camera Types

- **R13S** - Inside dumpster mounted camera (used primarily for front loads)
- **R13** - Outside dumpster mounted camera (used primarily for roll offs)

**R13S**



**R13**



## Required Tools

- Cordless drill
- Drill template (shipped with cameras\*)
- 1/8" drill bit
- 1/8"- 1/2" step bit
- 44mm hole saw (R13 Installation only)
- 3/8" tri-groove socket
- Washers, bolts & nuts for mounting (shipped with cameras\*)

*\*Additional parts can be shipped/emailed by request via [support@compology.com](mailto:support@compology.com)*

**compology**  
RECOMMENDED INSTALLATION  
LOCATIONS

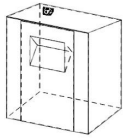

**2YD CLOTHES RECYCLE BIN  
UNSHIELDED SENSOR**  
SENSOR INSIDE BACK FACE  
TOP LEFT CORNER

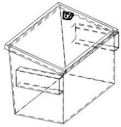
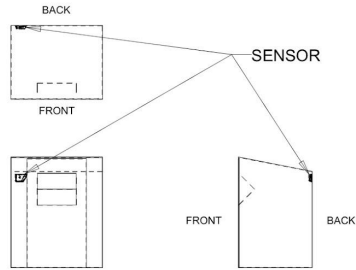

**2YD FRONT LOAD BIN  
UNSHIELDED SENSOR**  
SENSOR INSIDE RIGHT FACE  
TOP BACK CORNER

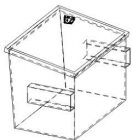
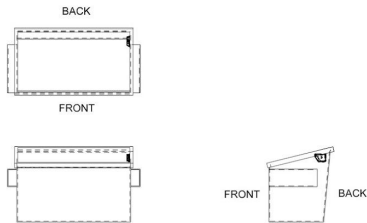

**3YD FRONT LOAD BIN  
UNSHIELDED SENSOR**  
SENSOR INSIDE RIGHT FACE  
TOP BACK CORNER

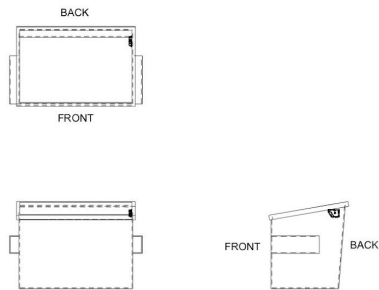

**compology**  
RECOMMENDED INSTALLATION  
LOCATIONS

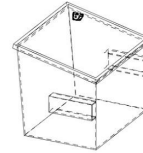

**4YD FRONT LOAD BIN  
UNSHIELDED SENSOR**  
SENSOR INSIDE RIGHT FACE  
TOP BACK CORNER

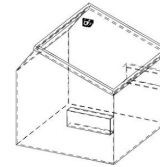
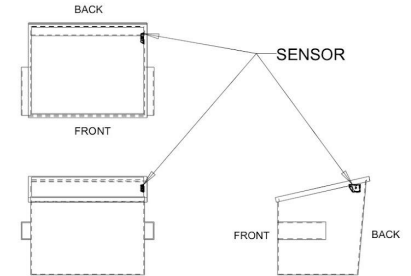

**6YD FRONT LOAD BIN  
UNSHIELDED SENSOR**  
SENSOR INSIDE RIGHT FACE  
REACHABLE HEIGHT AND PLACEMENT

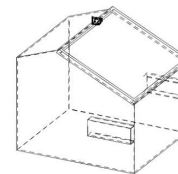
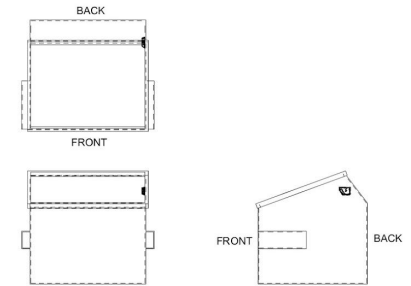

**8YD FRONT LOAD BIN  
UNSHIELDED SENSOR**  
SENSOR INSIDE RIGHT FACE  
REACHABLE HEIGHT AND PLACEMENT

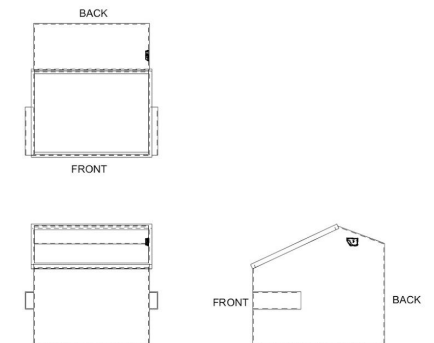

# **R13**

# **Install Instructions**

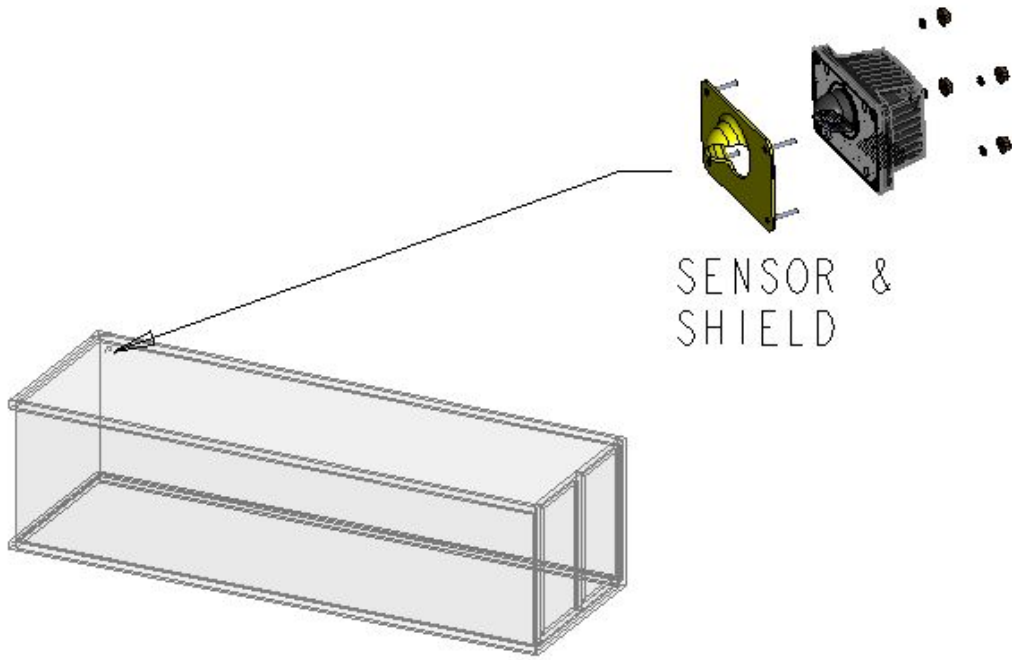

SENSOR &  
SHIELD

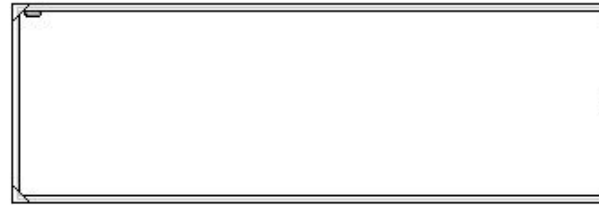

TOP VIEW



SIDE VIEW

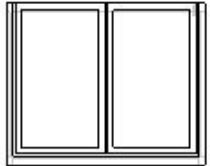

DOOR END

30YD ROLL OFF BIN

SENSOR LONG FACE  
OPPOSITE DOOR END  
TOP BACK CORNER



1. COMPLETE 'NEW INSTALL' WITH COMPOLOGY TECHNICIAN APP
2. POSITION TEMPLATE BELOW BIN'S TOP BOX BEAM
3. DRILL FIVE 3/16" HOLES (ALL CORNERS PLUS TURRET CENTER)

See 'Mounting Locations' document for positioning

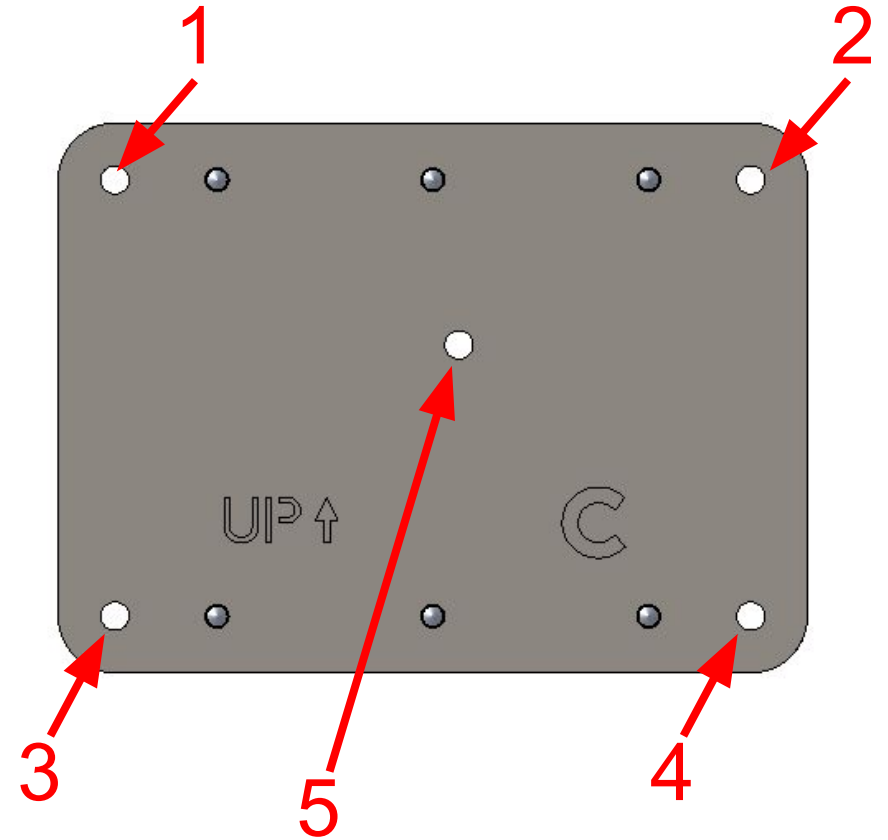
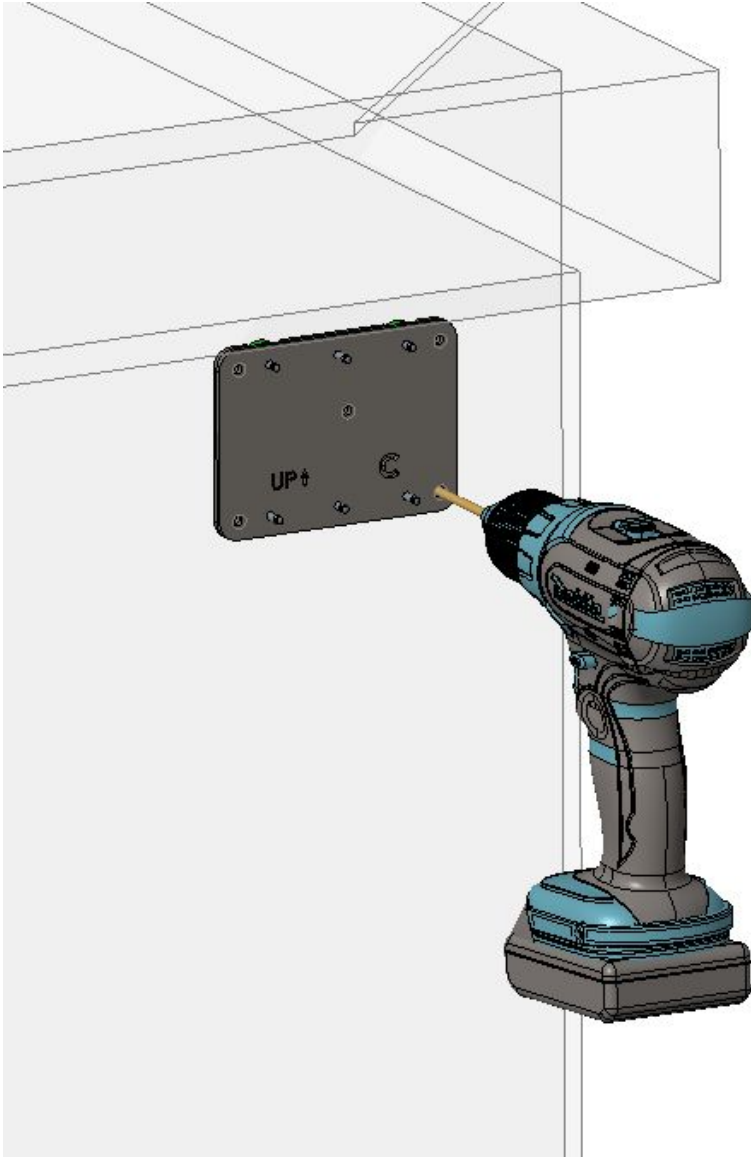

#### 4. OPEN UP CORNER HOLES USING STEP BIT

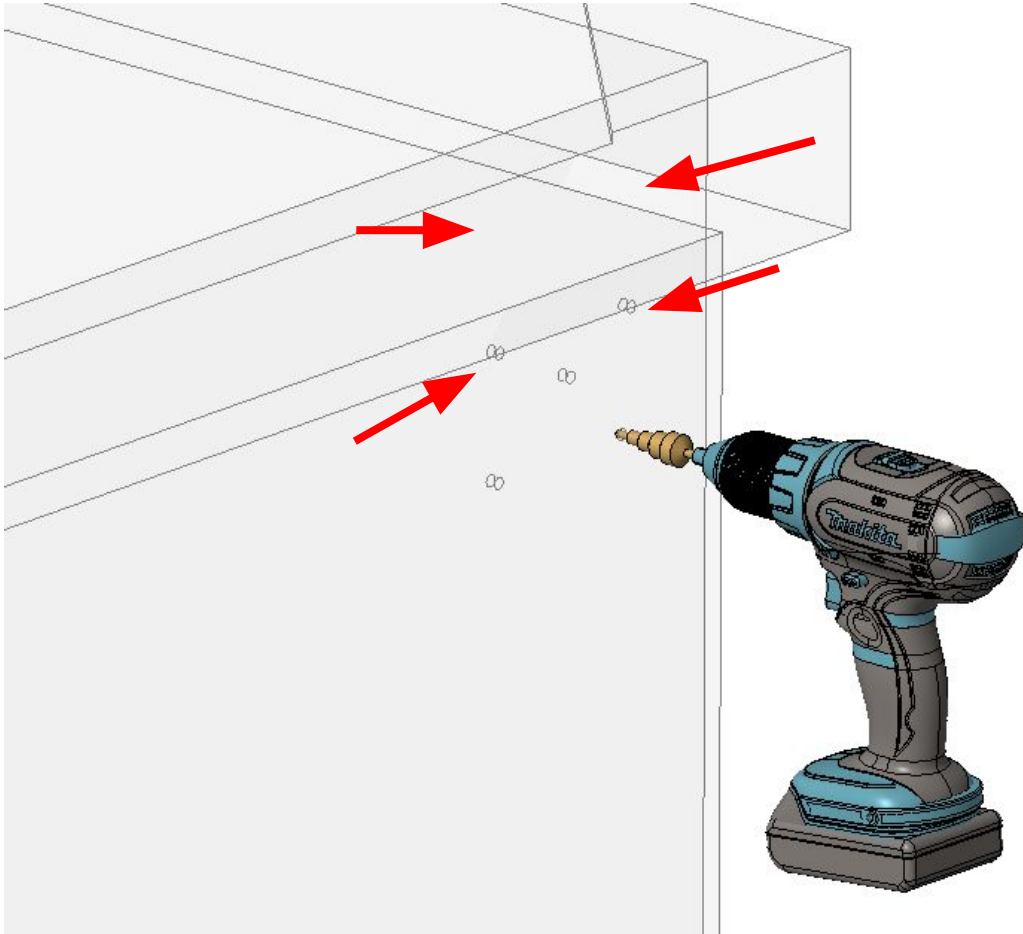

## 5. DRILL OUT CENTER HOLE WITH HOLE SAW

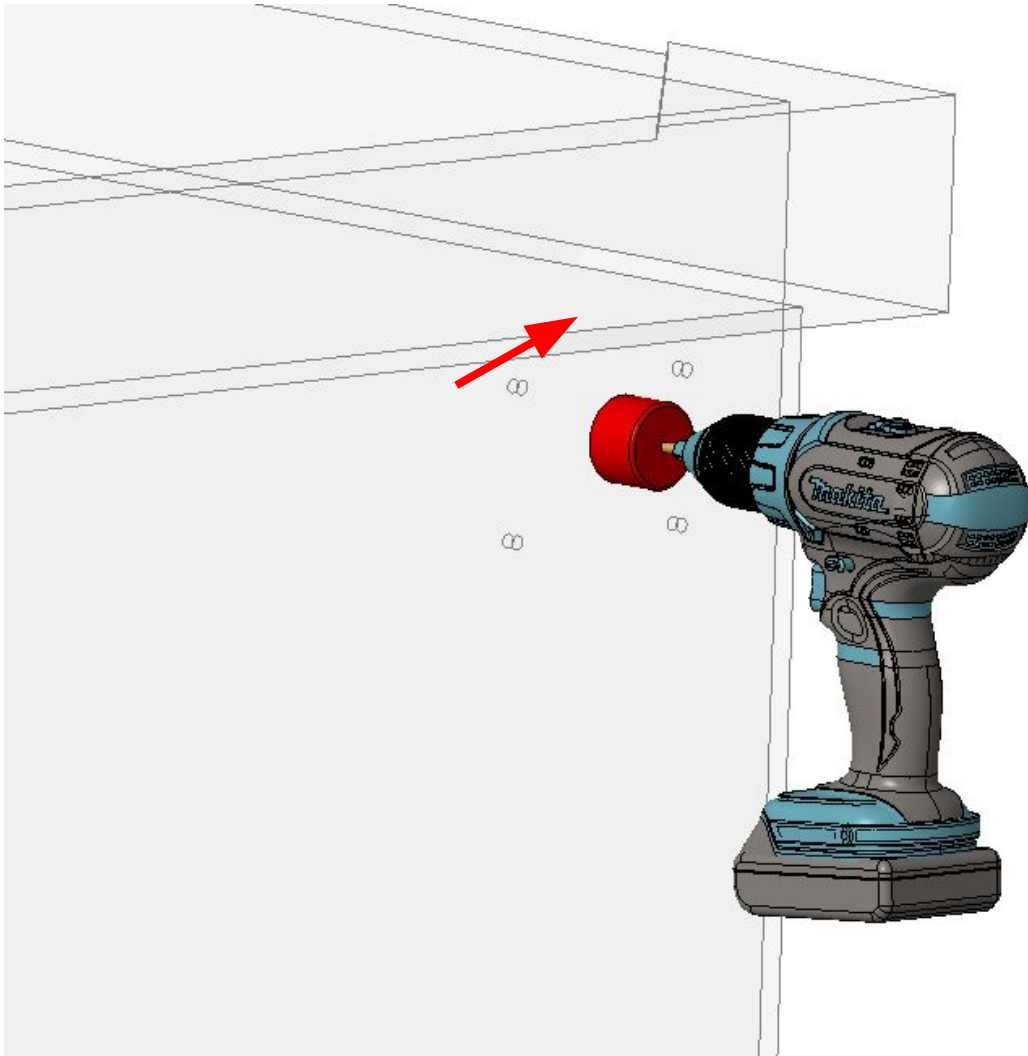

**6. REMOVE TAPE LINERS AND PLACE SHIELD ON INSIDE OF BIN. STUDS SHOULD ALL PENETRATE HOLES**

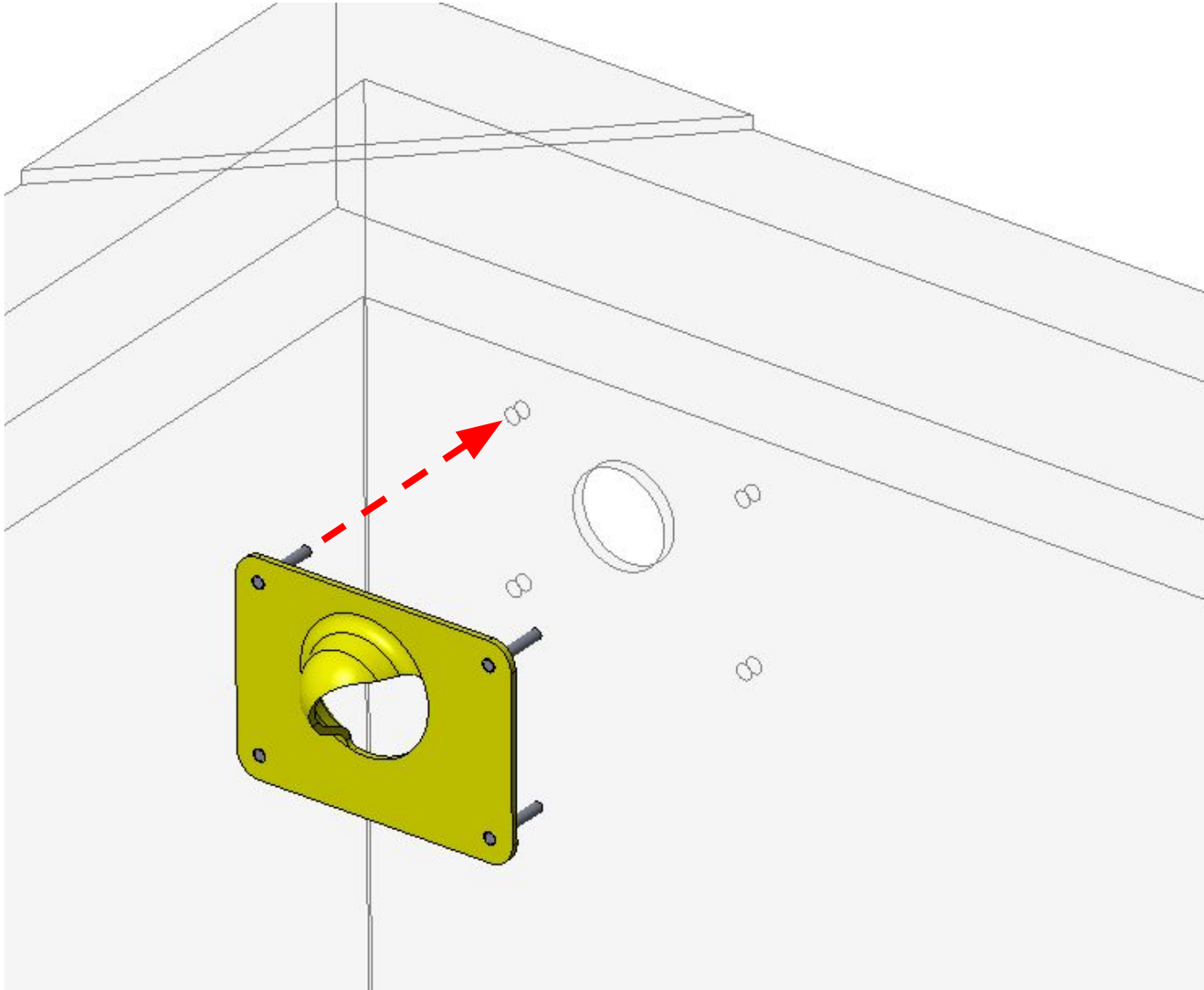

7. PLACE CAMERA ON STUDS (OUTSIDE OF BIN)
8. SECURE USING LOCK WASHERS AND SECURITY NUTS

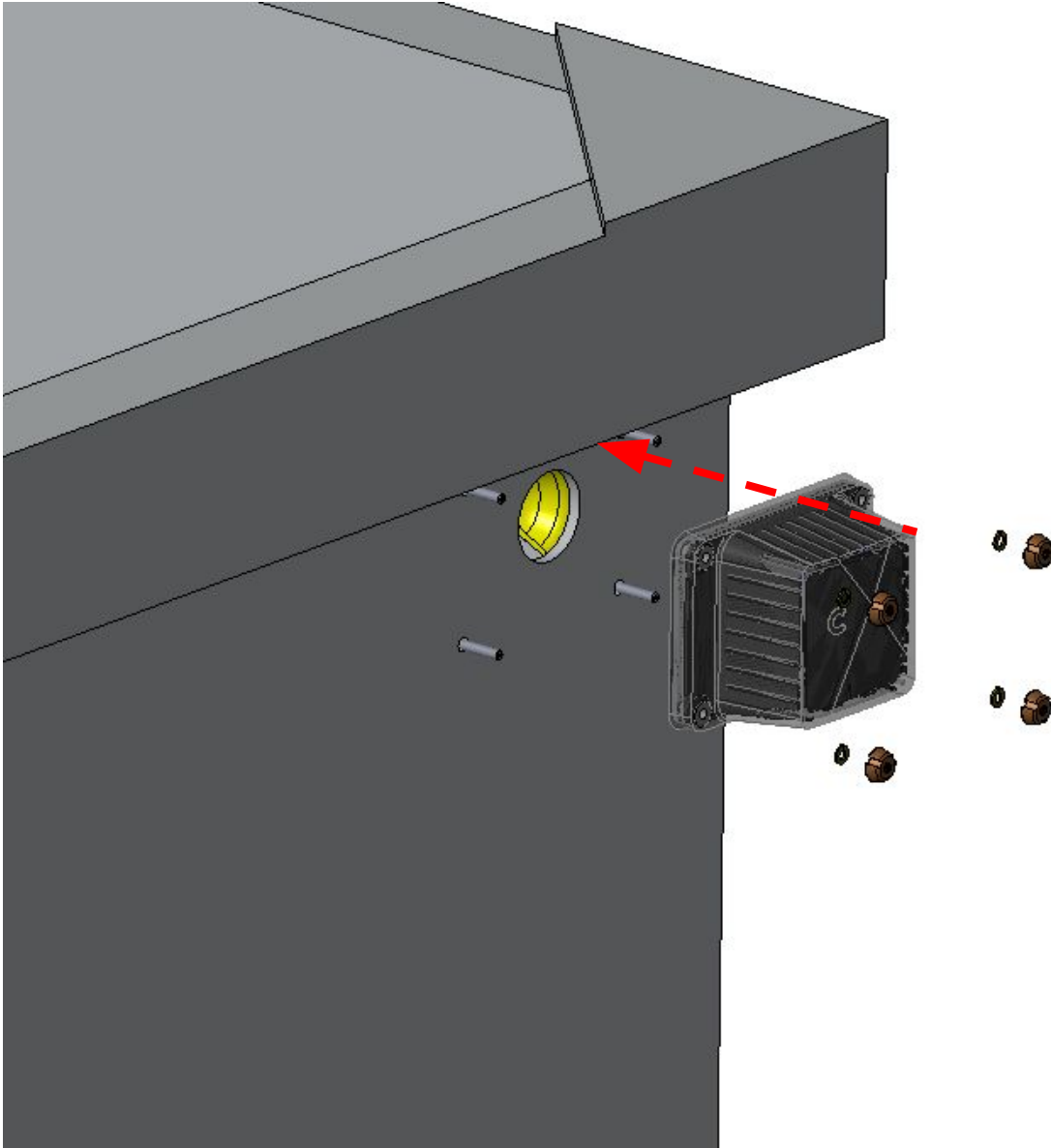

# **R13S Camera Installation (Bolts Mount)**

## How to Install the R13S Compology Camera (Bolts)



1. Consult the [container placement guide](#) and find the optimal location for camera. Peel tape covers on the back of the Cardboard Template (in box on top of camera). Place template in correct location on dumpster exterior surface



2. Drill two holes where indicated using 1/4" (6.35 mm or larger) bit



3. Remove and compost (or recycle) the template



4. Mount camera using screws and lock washers. Hand tighten securely with Pin-Torx T25 driver. Do not over-tighten





# **R13S Camera Installation (Adhesive Mount)**

## How to Install the R13S Compology Camera (Adhesive)



1. If the camera and bracket are separate, remove screw covers on camera using a flat head screwdriver.



2. Attach bracket using 2x M5 screws (included in adhesive kit). Replace screw covers.



3. Prepare bin surface using scour pad, making sure to remove any loose paint, rust or grime in mounting location. Ideally the surface should be clean, painted metal.



4. Take the alcohol swab and clean off any dust from the scouring process.

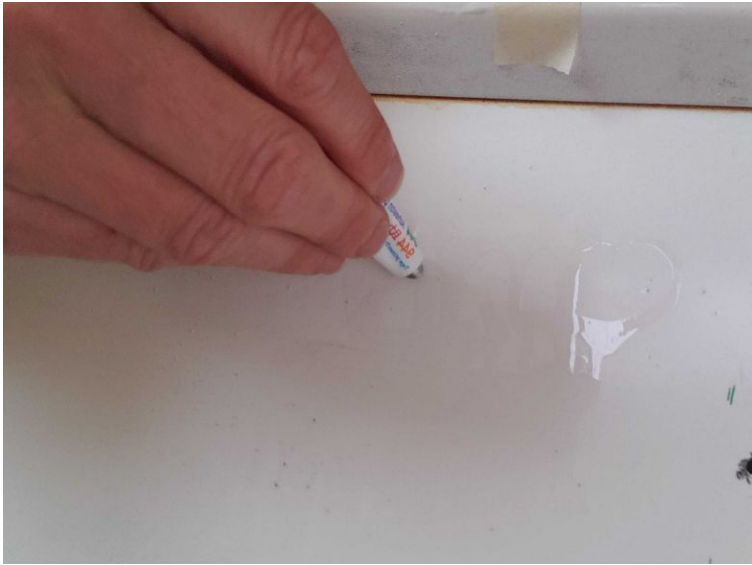

5. Open the primer tube by piercing the seal with the point on the lid. Spread a liberal amount of primer onto the mounting surface. **Take care not to get any primer on your skin or in your eyes, and keep away from open flames.**

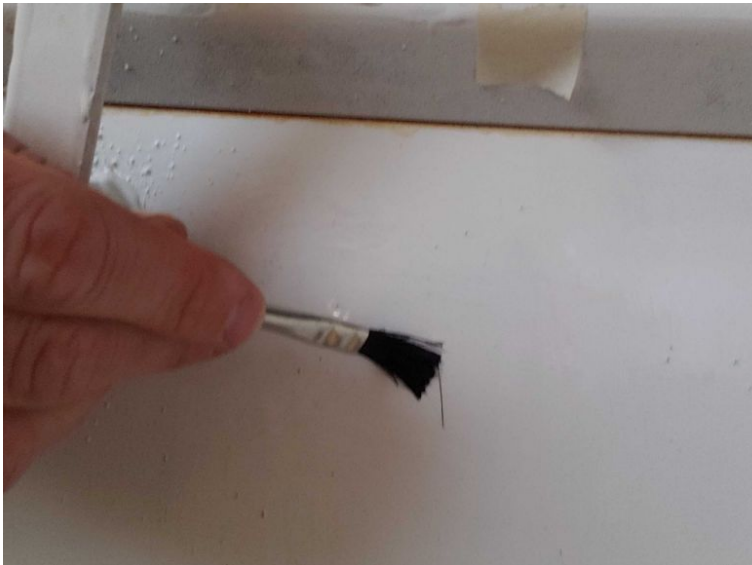

6. Using the small brush, ensure that the primer is evenly spread over the entire mounting area.



7. Peel off adhesive cover on template



8. Press firmly into place, exerting as much force as you can. **Hold for at least 30 seconds.**

# General Information

## Compology Contacts

Blake Miller

[blake@compology.com](mailto:blake@compology.com)

Reggie Williams

[reggie@compology.com](mailto:reggie@compology.com)

Dana Beck

[dana@compology.com](mailto:dana@compology.com)

Operations

[ops@compology.com](mailto:ops@compology.com)

## Compology HQ

40 Boardman Place

San Francisco, CA 94103

415-848-9169