

FCC 47 CFR PART 15 SUBPART E

CERTIFICATION TEST REPORT

For

OTT Dongle

MODEL No.: D2000

FCC ID: 2AO2A-S905X216

Trade Mark: inspur

REPORT NO.: ES180131012W04

ISSUE DATE: March 06, 2018

Prepared for

Inspur Software Group Ltd.

No. 2877 Kehang Rd., Jinan, Shandong, 250104 China

Prepared by

EMTEK(SHENZHEN) CO., LTD.

Bldg 69, Majialong Industry Zone, Nanshan District,
Shenzhen, Guangdong, China

TEL: 86-755-26954280

FAX: 86-755-26954282

1 TEST RESULT CERTIFICATION

Applicant:	Inspur Software Group Ltd. No. 2877 Kehang Rd., Jinan, Shandong, 250104 China
Manufacturer:	Inspur Software Group Ltd. No. 2877 Kehang Rd., Jinan, Shandong, 250104 China
Product Description:	OTT Dongle
Model Number:	D2000
Trade Mark:	inspur
File Number:	ES180131012W04

Measurement Procedure Used:

APPLICABLE STANDARDS	
STANDARD	TEST RESULT
FCC 47 CFR Part 2, Subpart J FCC 47 CFR Part 15, Subpart E	PASS

The above equipment was tested by EMTEK(SHENZHEN) CO., LTD.. The test data, data evaluation, test procedures, and equipment configurations shown in this report were made in accordance with the procedures given in ANSI C63.10 (2013) and the energy emitted by the sample EUT tested as described in this report is in compliance with the requirements of FCC Rules Part 2 and Part 15.407

The test results of this report relate only to the tested sample identified in this report.

Date of Test : January 31, 2018 to March 06, 2018

Prepared by: 
Yaping Shen/Editor

Reviewer: 
Sevin Li /Supervisor

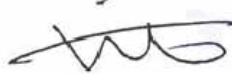
Approve & Authorized Signer : 
Lisa Wang/Manager



TABLE OF CONTENTS

1 TEST RESULT CERTIFICATION2

2 EUT TECHNICAL DESCRIPTION4

3 SUMMARY OF TEST RESULT6

4 TEST METHODOLOGY.....7

4.1 GENERAL DESCRIPTION OF APPLIED STANDARDS7

4.2 MEASUREMENT EQUIPMENT USED7

4.3 DESCRIPTION OF TEST MODES8

5 FACILITIES AND ACCREDITATIONS13

5.1 FACILITIES.....13

5.2 LABORATORY ACCREDITATIONS AND LISTINGS13

6 TEST SYSTEM UNCERTAINTY14

7 SETUP OF EQUIPMENT UNDER TEST15

7.1 RADIO FREQUENCY TEST SETUP15

7.2 RADIO FREQUENCY TEST SETUP15

7.3 CONDUCTED EMISSION TEST SETUP17

7.4 BLOCK DIAGRAM CONFIGURATION OF TEST SYSTEM.....18

7.5 SUPPORT EQUIPMENT.....18

8 TEST REQUIREMENTS19

8.1 BANDWIDTH MEASUREMENT19

8.2 MAXIMUM CONDUCTED OUTPUT POWER.....96

8.3 MAXIMUM PEAK POWER DENSITY101

8.4 FREQUENCY STABILITY106

8.5 UNDESIRABLE RADIATED SPURIOUS EMISSION.....127

8.6 POWER LINE CONDUCTED EMISSIONS.....170

8.7 ANTENNA APPLICATION173

2 EUT TECHNICAL DESCRIPTION

Characteristics	Description																																												
IEEE 802.11 WLAN Mode Supported	<input checked="" type="checkbox"/> 802.11a(20MHz channel bandwidth) <input checked="" type="checkbox"/> 802.11n(20MHz channel bandwidth) <input checked="" type="checkbox"/> 802.11n(40MHz channel bandwidth) <input checked="" type="checkbox"/> 802.11ac(20MHz channel bandwidth) <input checked="" type="checkbox"/> 802.11ac(40MHz channel bandwidth) <input checked="" type="checkbox"/> 802.11ac(80MHz channel bandwidth)																																												
Data Rate	802.11 a:6,9,12,18,24,36,48,54Mbps; 802.11n(HT20)/ac(HT20): MCS0-MCS7; 802.11n(HT40): MCS0-MCS7; 802.11ac(HT40):MCS0-MCS9; 802.11ac(VHT80):MCS0-MCS9;																																												
Modulation	OFDM with BPSK/QPSK/16QAM/64QAM for 802.11a/n; OFDM with BPSK/QPSK/16QAM/64QAM/256QAM for 802.11ac;																																												
Operating Frequency Range	<table border="1"> <thead> <tr> <th>WIFI 5G Band</th> <th>Mode</th> <th>Frequency Range(MHz)</th> <th>Number of channels</th> </tr> </thead> <tbody> <tr> <td rowspan="3">UNII Band I</td> <td>802.11a/n(HT20)/ac(VHT20)</td> <td>5180-5240</td> <td>4</td> </tr> <tr> <td>802.11n(HT40)/ac(VHT40)</td> <td>5190-5230</td> <td>2</td> </tr> <tr> <td>802.11 ac(VHT80)</td> <td>5210</td> <td>1</td> </tr> <tr> <td rowspan="3">UNII Band II-A</td> <td>802.11a/n(HT20)/ac(VHT20)</td> <td>5260-5320</td> <td>4</td> </tr> <tr> <td>802.11n(HT40)/ac(VHT40)</td> <td>5270-5310</td> <td>2</td> </tr> <tr> <td>802.11 ac(VHT80)</td> <td>5290</td> <td>1</td> </tr> <tr> <td rowspan="3">UNII Band II-C</td> <td>802.11a/n(HT20)/ac(VHT20)</td> <td>5500-5700</td> <td>11</td> </tr> <tr> <td>802.11n(HT40)/ac(VHT40)</td> <td>5510-5670</td> <td>5</td> </tr> <tr> <td>802.11 ac(VHT80)</td> <td>5530-5610</td> <td>2</td> </tr> <tr> <td rowspan="3">UNII Band III</td> <td>802.11a/n(HT20)/ac(VHT20)</td> <td>5745-5825</td> <td>5</td> </tr> <tr> <td>802.11n(HT40)/ac(VHT40)</td> <td>5755-5795</td> <td>2</td> </tr> <tr> <td>802.11 ac(VHT80)</td> <td>5775</td> <td>1</td> </tr> </tbody> </table>	WIFI 5G Band	Mode	Frequency Range(MHz)	Number of channels	UNII Band I	802.11a/n(HT20)/ac(VHT20)	5180-5240	4	802.11n(HT40)/ac(VHT40)	5190-5230	2	802.11 ac(VHT80)	5210	1	UNII Band II-A	802.11a/n(HT20)/ac(VHT20)	5260-5320	4	802.11n(HT40)/ac(VHT40)	5270-5310	2	802.11 ac(VHT80)	5290	1	UNII Band II-C	802.11a/n(HT20)/ac(VHT20)	5500-5700	11	802.11n(HT40)/ac(VHT40)	5510-5670	5	802.11 ac(VHT80)	5530-5610	2	UNII Band III	802.11a/n(HT20)/ac(VHT20)	5745-5825	5	802.11n(HT40)/ac(VHT40)	5755-5795	2	802.11 ac(VHT80)	5775	1
	WIFI 5G Band	Mode	Frequency Range(MHz)	Number of channels																																									
	UNII Band I	802.11a/n(HT20)/ac(VHT20)	5180-5240	4																																									
		802.11n(HT40)/ac(VHT40)	5190-5230	2																																									
		802.11 ac(VHT80)	5210	1																																									
	UNII Band II-A	802.11a/n(HT20)/ac(VHT20)	5260-5320	4																																									
		802.11n(HT40)/ac(VHT40)	5270-5310	2																																									
		802.11 ac(VHT80)	5290	1																																									
	UNII Band II-C	802.11a/n(HT20)/ac(VHT20)	5500-5700	11																																									
		802.11n(HT40)/ac(VHT40)	5510-5670	5																																									
		802.11 ac(VHT80)	5530-5610	2																																									
	UNII Band III	802.11a/n(HT20)/ac(VHT20)	5745-5825	5																																									
802.11n(HT40)/ac(VHT40)		5755-5795	2																																										
802.11 ac(VHT80)		5775	1																																										
Transmit Power Max	19.63 dBm for UNII Band I 19.24 dBm for UNII Band II-A 18.99 dBm for UNII Band II-C 19.16 dBm for UNII Band III																																												
Antenna Type	Antenna 1: Metal antenna Antenna 2: Metal antenna																																												
Smart system	<input checked="" type="checkbox"/> SISO <input checked="" type="checkbox"/>MIMO																																												
Antenna Gain	4.5 dBi																																												
Direction Gain	7.51 dBi																																												

Power supply	<input type="checkbox"/> DC 3.7V internal rechargeable lithium battery
	<input checked="" type="checkbox"/> DC 5V from Adapter
	<input checked="" type="checkbox"/> Adapter: Model: EJVD+100050-2000 Input: AC 100-240V 50/60Hz 0.3A Output: DC 5V 2A

Note: for more details, please refer to the User's manual of the EUT.

3 SUMMARY OF TEST RESULT

FCC Part Clause	Test Parameter	Verdict	Remark
15.407 (a) 15.407 (e)	99% , 6dB and 26dB Bandwidth	PASS	
15.407 (a)	Maximum Conducted Output Power	PASS	
15.407 (a)	Peak Power Spectral Density	PASS	
15.407 (b)	Radiated Spurious Emission	PASS	
15.407(g)	Frequency Stability	PASS	
15.407 (b)(6) 15.207	Power Line Conducted Emission	PASS	
15.407(a) 15.203	Antenna Application	PASS	
NOTE1: N/A (Not Applicable)			
NOTE2: According to FCC OET KDB 789033 D2 General UNII Test Procedures New Rules v01r02, In addition, the radiated test is also performed to ensure the emissions emanating from the device cabinet also comply with the applicable limits.			

RELATED SUBMITTAL(S) / GRANT(S):

This submittal(s) (test report) is intended for FCC ID: 2AO2A-S905X216 filing to comply with Section 15.247 of the FCC Part 15, Subpart E Rules.

4 TEST METHODOLOGY

4.1 GENERAL DESCRIPTION OF APPLIED STANDARDS

According to its specifications, the EUT must comply with the requirements of the following standards:

FCC 47 CFR Part 2, Subpart J

FCC 47 CFR Part 15, Subpart E

FCC KDB 789033 D2 General UNII Test Procedures New Rules v01r04

FCC KDB 662911 D01 Multiple Transmitter Output v02r01

FCC KDB 662911 D02 MIMO With Cross Polarized Antenna V01

4.2 MEASUREMENT EQUIPMENT USED

4.2.1 Conducted Emission Test Equipment

EQUIPMENT TYPE	MFR	MODEL NUMBER	SERIAL NUMBER	LAST CAL.	DUE CAL.
Test Receiver	Rohde & Schwarz	ESCI	26115-010-0027	May 20, 2017	May 19, 2018
L.I.S.N.	Rohde & Schwarz	ENV216	101161	May 20, 2017	May 19, 2018
50Ω Coaxial Switch	Anritsu	MP59B	6100175589	May 21, 2017	May 20, 2018
Voltage Probe	Rohde & Schwarz	ESH2-Z3	100122	May 21, 2017	May 20, 2018
Pulse Limiter	Rohde & Schwarz	ESH3-Z2	100006	May 20, 2017	May 19, 2018
I.S.N	Teseq GmbH	ISN T800	30327	May 21, 2017	May 20, 2018

4.2.2 Radiated Emission Test Equipment

EQUIPMENT TYPE	MFR	MODEL NUMBER	SERIAL NUMBER	LAST CAL.	DUE CAL.
EMI Test Receiver	Rohde & Schwarz	ESU	1302.6005.26	May 21, 2017	May 20, 2018
Pre-Amplifier	HP	8447F	2944A07999	May 20, 2017	May 19, 2018
Bilog Antenna	Schwarzbeck	VULB9163	142	May 20, 2017	May 19, 2018
Loop Antenna	ARA	PLA-1030/B	1029	May 20, 2017	May 19, 2018
Horn Antenna	Schwarzbeck	BBHA 9170	BBHA9170399	May 21, 2017	May 20, 2018
Horn Antenna	Schwarzbeck	BBHA 9120	D143	May 20, 2017	May 19, 2018
Cable	Schwarzbeck	AK9513	ACRX1	May 21, 2017	May 20, 2018
Cable	Rosenberger	N/A	FP2RX2	May 21, 2017	May 20, 2018
Cable	Schwarzbeck	AK9513	CRPX1	May 21, 2017	May 20, 2018
Cable	Schwarzbeck	AK9513	CRRX2	May 21, 2017	May 20, 2018

4.2.3 Radio Frequency Test Equipment

EQUIPMENT TYPE	MFR	MODEL NUMBER	SERIAL NUMBER	LAST CAL.	DUE CAL.
Spectrum Analyzer	Agilent	E4407B	88156318	May 21, 2017	May 20, 2018
Signal Analyzer	Agilent	N9010A	My53470879	May 21, 2017	May 20, 2018
Power meter	Anritsu	ML2495A	0824006	May 21, 2017	May 20, 2018
Power sensor	Anritsu	MA2411B	0738172	May 21, 2017	May 20, 2018
Spectrum Analyzer	Agilent	E4407B	88156318	May 21, 2017	May 20, 2018

Remark: Each piece of equipment is scheduled for calibration once a year.

4.3 DESCRIPTION OF TEST MODES

The EUT has been tested under its typical operating condition.

The EUT configuration for testing is installed on RF field strength measurement to meet the Commissions requirement and operating in a manner which intends to maximize its emission characteristics in a continuous normal application.

The Transmitter was operated in the normal operating mode. The TX frequency was fixed which was for the purpose of the measurements.

Test of channel included the lowest and middle and highest frequency to perform the test, then record on this report.

Those data rates (802.11a: 6 Mbps; 802.11n (HT20): MCS0; 802.11n (HT20): MCS15; 802.11n (HT40): MCS0; 802.11n (HT40): MCS15; 802.11ac (HT20): MCS0; 802.11ac (HT20): MCS15; 802.11ac (HT40): MCS0; 802.11ac (HT40): MCS19; 802.11ac (HT80): MCS0; 802.11ac (HT80): MCS19;) were used for all test.

Pre-defined engineering program for regulatory testing used to control the EUT for staying in continuous transmitting and receiving mode is programmed.

Wifi 5G with UNII Band I

Frequency and Channel list for 802.11a/n(HT20)/ac(VHT20):

Channel	Frequency (MHz)	Channel	Frequency (MHz)	Channel	Frequency (MHz)
36	5180	44	5220		
40	5200	48	5240		

Frequency and Channel list for 802.11n(HT40)/ac(VHT40):

Channel	Frequency (MHz)	Channel	Frequency (MHz)	Channel	Frequency (MHz)
38	5190				
46	5230				

Frequency and Channel list for 802.11ac(VHT80):

Channel	Frequency (MHz)	Channel	Frequency (MHz)	Channel	Frequency (MHz)
42	5210				

Test Frequency and Channel for 802.11a/n(HT20)/ac(VHT20):

Lowest Frequency		Middle Frequency		Highest Frequency	
Channel	Frequency (MHz)	Channel	Frequency (MHz)	Channel	Frequency (MHz)
36	5180	40	5200	48	5240

Test Frequency and channel for 802.11n(VHT40)/ac(VHT40):

Lowest Frequency		Middle Frequency		Highest Frequency	
Channel	Frequency (MHz)	Channel	Frequency (MHz)	Channel	Frequency (MHz)
38	5190	N/A	N/A	46	5230

Test Frequency and channel for 802.11ac(HT80):

Lowest Frequency		Middle Frequency		Highest Frequency	
Channel	Frequency (MHz)	Channel	Frequency (MHz)	Channel	Frequency (MHz)
42	5210	N/A	N/A	N/A	N/A

Wifi 5G with UNII Band II-A

Frequency and Channel list for 802.11a/n(HT20)/ac(VHT20):

Channel	Frequency (MHz)	Channel	Frequency (MHz)	Channel	Frequency (MHz)
52	5260	60	5300		
56	5280	64	5320		

Frequency and Channel list for 802.11n(VHT40)/ac(VHT40):

Channel	Frequency (MHz)	Channel	Frequency (MHz)	Channel	Frequency (MHz)
54	5270				
62	5310				

Frequency and Channel list for 802.11ac(VHT80):

Channel	Frequency (MHz)	Channel	Frequency (MHz)	Channel	Frequency (MHz)
58	5290				

Test Frequency and Channel for 802.11a/n(HT20)/ac(VHT20):

Lowest Frequency		Middle Frequency		Highest Frequency	
Channel	Frequency (MHz)	Channel	Frequency (MHz)	Channel	Frequency (MHz)
52	5260	56	5280	64	5320

Test Frequency and channel for 802.11n(HT40)/ac(VHT40):

Lowest Frequency		Middle Frequency		Highest Frequency	
Channel	Frequency (MHz)	Channel	Frequency (MHz)	Channel	Frequency (MHz)
54	5270	N/A	N/A	62	5310

Test Frequency and channel for 802.11ac(VHT80):

Lowest Frequency		Middle Frequency		Highest Frequency	
Channel	Frequency (MHz)	Channel	Frequency (MHz)	Channel	Frequency (MHz)
58	5290	N/A	N/A	N/A	N/A

Wifi 5G with UNII Band II-C

Frequency and Channel list for 802.11a/n(HT20)/ac(VHT20):

Channel	Frequency (MHz)	Channel	Frequency (MHz)	Channel	Frequency (MHz)
100	5500	116	5580	132	5660
104	5520	120	5600	136	5680
108	5540	124	5620	140	5700
112	5560	128	5640		

Frequency and Channel list for 802.11n(VHT40)/ac(VHT40):

Channel	Frequency (MHz)	Channel	Frequency (MHz)	Channel	Frequency (MHz)
102	5510	126	5630		
110	5550	134	5670		
118	5590				

Frequency and Channel list for 802.11ac(VHT80):

Channel	Frequency (MHz)	Channel	Frequency (MHz)	Channel	Frequency (MHz)
106	5530				
122	5610				

Test Frequency and Channel for 802.11a/n(HT20)/ac(VHT20):

Lowest Frequency		Middle Frequency		Highest Frequency	
Channel	Frequency (MHz)	Channel	Frequency (MHz)	Channel	Frequency (MHz)
100	5500	120	5600	140	5700

Test Frequency and channel for 802.11n(VHT40)/ac(VHT40):

Lowest Frequency		Middle Frequency		Highest Frequency	
Channel	Frequency (MHz)	Channel	Frequency (MHz)	Channel	Frequency (MHz)
102	5510	118	5590	134	5670

Test Frequency and channel for 802.11ac(VHT80):

Lowest Frequency		Middle Frequency		Highest Frequency	
Channel	Frequency (MHz)	Channel	Frequency (MHz)	Channel	Frequency (MHz)
106	5530	N/A	N/A	122	5610

Wifi 5G with UNII Band III

Frequency and Channel list for 802.11a/n(HT20)/ac(VHT20):

Channel	Frequency (MHz)	Channel	Frequency (MHz)	Channel	Frequency (MHz)
149	5745	157	5785	165	5825
153	5765	161	5805		

Frequency and Channel list for 802.11n(HT40)/ac(VHT40):

Channel	Frequency (MHz)	Channel	Frequency (MHz)	Channel	Frequency (MHz)
151	5755				
159	5795				

Frequency and Channel list for 802.11ac(VHT80):

Channel	Frequency (MHz)	Channel	Frequency (MHz)	Channel	Frequency (MHz)
155	5775				

Test Frequency and Channel for 802.11a/n(HT20)/ac(VHT20):

Lowest Frequency		Middle Frequency		Highest Frequency	
Channel	Frequency (MHz)	Channel	Frequency (MHz)	Channel	Frequency (MHz)
149	5745	157	5785	165	5825

Test Frequency and channel for 802.11n(HT40)/ac(VHT40):

Lowest Frequency		Middle Frequency		Highest Frequency	
Channel	Frequency (MHz)	Channel	Frequency (MHz)	Channel	Frequency (MHz)
151	5755	N/A	N/A	159	5795

Test Frequency and channel for 802.11ac(VHT80):

Lowest Frequency		Middle Frequency		Highest Frequency	
Channel	Frequency (MHz)	Channel	Frequency (MHz)	Channel	Frequency (MHz)
155	5775				

5 FACILITIES AND ACCREDITATIONS

5.1 FACILITIES

All measurement facilities used to collect the measurement data are located at

Bldg 69, Majialong Industry Zone District, Nanshan District, Shenzhen, China

The sites are constructed in conformance with the requirements of ANSI C63.7, ANSI C63.10 and CISPR Publication 22.

5.2 LABORATORY ACCREDITATIONS AND LISTINGS

Site Description

EMC Lab.

: Accredited by CNAS,2016.10.24

The certificate is valid until 2022.10.28

The Laboratory has been assessed and proved to be in compliance with CNAS-CL01:2006 (identical to ISO/IEC 17025:2005)

The Certificate Registration Number is L2291.

Accredited by TUV Rheinland Shenzhen 2016.5.19

The Laboratory has been assessed according to the requirements ISO/IEC 17025.

Accredited by FCC, August 03, 2017

Designation Number: CN1204

Test Firm Registration Number: 882943

Accredited by A2LA, July 31, 2017

The Certificate Registration Number is 4321.01.

Accredited by Industry Canada, November 29, 2012

The Certificate Registration Number is 4480A.

Name of Firm

: EMTEK(SHENZHEN) CO., LTD.

Site Location

: Bldg 69, Majialong Industry Zone,
Nanshan District, Shenzhen, Guangdong, China

6 TEST SYSTEM UNCERTAINTY

The following measurement uncertainty levels have been estimated for tests performed on the apparatus:

Parameter	Uncertainty
Radio Frequency	$\pm 1 \times 10^{-5}$
Maximum Peak Output Power Test	$\pm 1.0\text{dB}$
Conducted Emissions Test	$\pm 2.0\text{dB}$
Radiated Emission Test	$\pm 2.0\text{dB}$
Power Density	$\pm 2.0\text{dB}$
Occupied Bandwidth Test	$\pm 1.0\text{dB}$
Band Edge Test	$\pm 3\text{dB}$
All emission, radiated	$\pm 3\text{dB}$
Antenna Port Emission	$\pm 3\text{dB}$
Temperature	± 0.5
Humidity	$\pm 3\%$

Measurement Uncertainty for a level of Confidence of 95%

7 SETUP OF EQUIPMENT UNDER TEST

7.1 RADIO FREQUENCY TEST SETUP

The WLAN component's antenna ports(s) of the EUT are connected to the measurement instrument per an appropriate attenuator. The EUT is controlled by PC/software to emit the specified signals for the purpose of measurements.

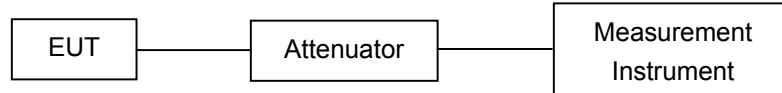

7.2 RADIO FREQUENCY TEST SETUP

The test site semi-anechoic chamber has met the requirement of NSA tolerance 4 dB according to the standards: ANSI C63.10. The test distance is 3m. The setup is according to the requirements in Section 13.1.4.1 of ANSI C63.10-2013 and CAN/CSA-CEI/IEC CISPR 22.

Below 30MHz :

The EUT is placed on a turntable 0.8 meters above the ground in the chamber, 3 meter away from the antenna (loop antenna). The Antenna should be positioned with its plane vertical at the specified distance from the EUT and rotated about its vertical axis for maximum response at each azimuth about the EUT. The center of the loop shall be 1 m above the ground. For certain applications, the loop antenna plane may also need to be positioned horizontally at the specified distance from the EUT.

Above 30MHz :

The EUT is placed on a turntable 0.8 meters above the ground in the chamber, 3 meter away from the antenna. The maximal emission value is acquired by adjusting the antenna height, polarisation and turntable azimuth. Normally, the height range of antenna is 1 m to 4 m, the azimuth range of turntable is 0° to 360°, and the receive antenna has two polarizations Vertical (V) and Horizontal (H).

Above 1GHz :

(Note: the FCC's permission to use 1.5m as an alternative per TCBC Conf call of Dec. 2, 2014.)

The EUT is placed on a turntable 1.5 meters above the ground in the chamber, 3 meter away from the antenna. The maximal emission value is acquired by adjusting the antenna height, polarisation and turntable azimuth. Normally, the height range of antenna is 1 m to 4 m, the azimuth range of turntable is 0° to 360°, and the receive antenna has two polarizations Vertical (V) and Horizontal (H).

(a) Radiated Emission Test Set-Up, Frequency Below 30MHz

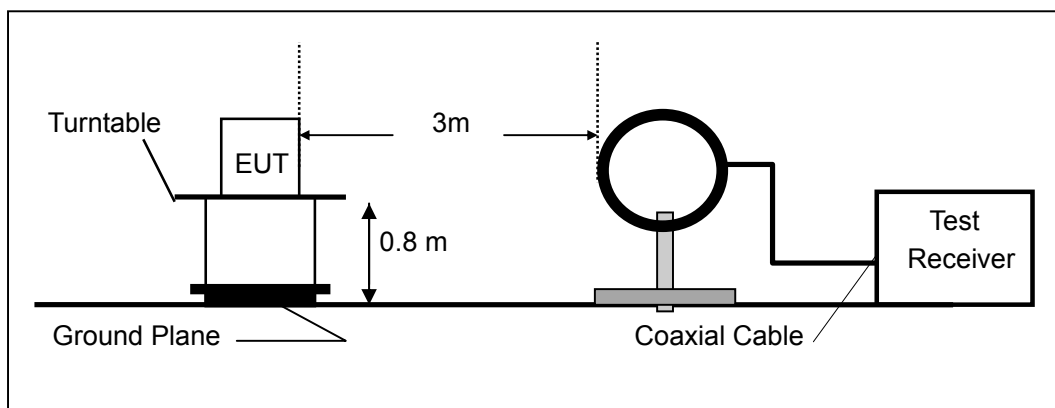

(b) Radiated Emission Test Set-Up, Frequency Below 1000MHz

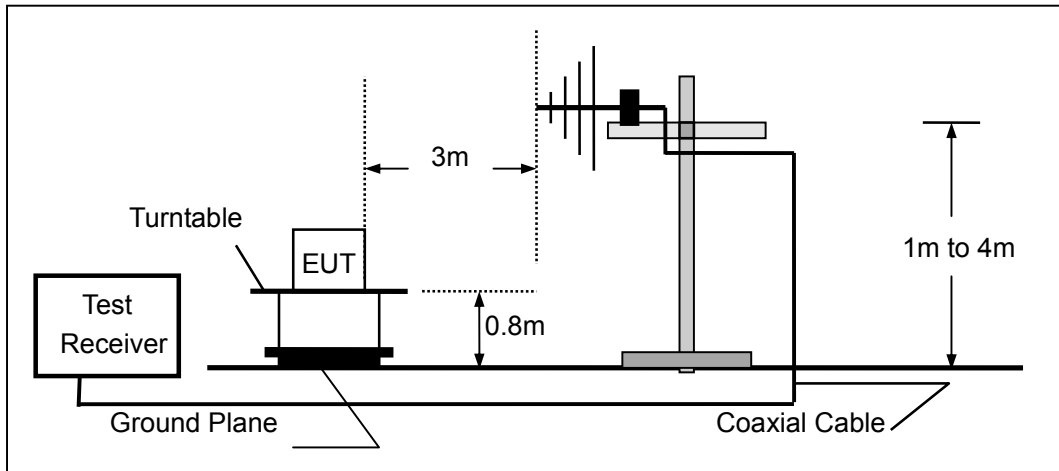

(c) Radiated Emission Test Set-Up, Frequency above 1000MHz

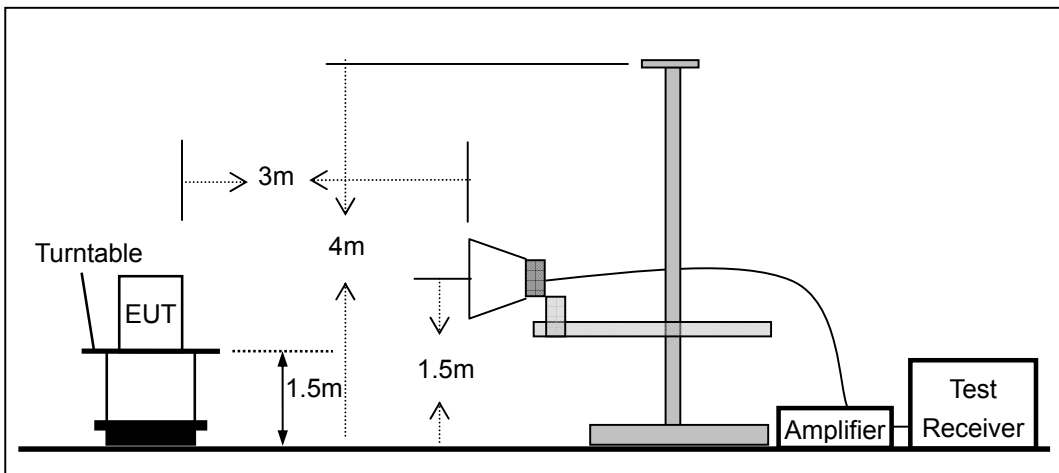

7.3 CONDUCTED EMISSION TEST SETUP

The mains cable of the EUT (maybe per AC/DC Adapter) must be connected to LISN. The LISN shall be placed 0.8 m from the boundary of EUT and bonded to a ground reference plane for LISN mounted on top of the ground reference plane. This distance is between the closest points of the LISN and the EUT. All other units of the EUT and associated equipment shall be at least 0.8m from the LISN.

Ground connections, where required for safety purposes, shall be connected to the reference ground point of the LISN and, where not otherwise provided or specified by the manufacturer, shall be of same length as the mains cable and run parallel to the mains connection at a separation distance of not more than 0.1 m.

According to the requirements in Section 13.1.4.1 of ANSI C63.10-2013 Conducted emissions from the EUT measured in the frequency range between 0.15 MHz and 30 MHz using CISPR Quasi-Peak and average detector mode.

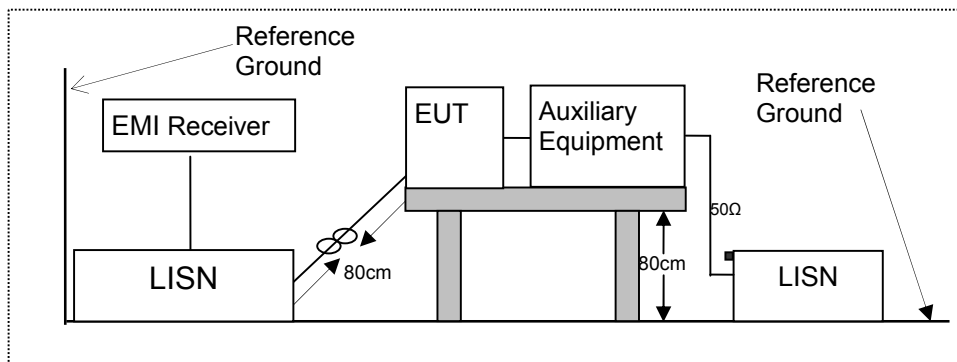

7.4 BLOCK DIAGRAM CONFIGURATION OF TEST SYSTEM

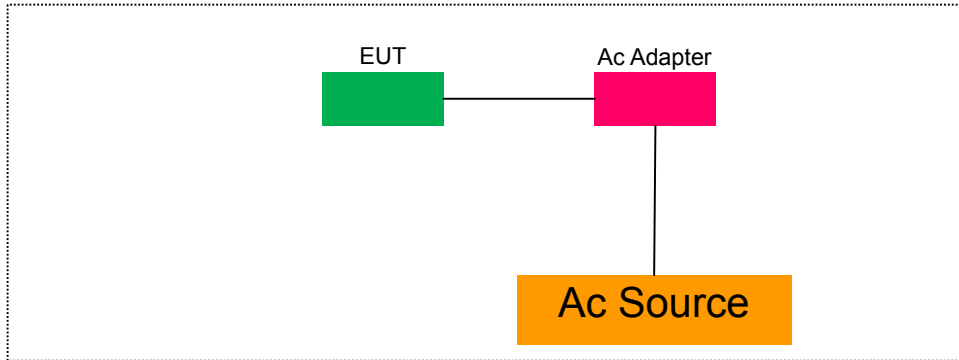

7.5 SUPPORT EQUIPMENT

Item	Equipment	Mfr/Brand	Model/Type No.	FCC ID	Series No.	Note
N/A	N/A	N/A	N/A	N/A	N/A	N/A

Notes:

1. All the equipment/cables were placed in the worst-case configuration to maximize the emission during the test.
2. Grounding was established in accordance with the manufacturer's requirements and conditions for the intended use.

8 TEST REQUIREMENTS

8.1 BANDWIDTH MEASUREMENT

8.1.1 Applicable Standard

According to FCC Part 15.407(a)(1) for UNII Band I
According to FCC Part 15.407(a)(2) for UNII Band II-A and UNII Band II-C
According to FCC Part 15.407(a)(3) for UNII Band III
According to FCC Part 15.407(e) for UNII Band III
According to 789033 D02 Section II(C)
According to 789033 D02 Section II(D)

8.1.2 Conformance Limit

No limit requirement.
The minimum 6 dB emission bandwidth of at least 500 KHz for the UNII Band III.

8.1.3 Test Configuration

Test according to clause 6.1 radio frequency test setup

8.1.4 Test Procedure

Connect the antenna port(s) to the spectrum analyzer input. Using the spectrum analyzer Channel Bandwidth mode, configure the spectrum analyzer as shown below

■ The following procedure shall be used for measuring (26 dB) power bandwidth:

Center Frequency: test Frequency

Set RBW = approximately 1% of the emission bandwidth.

Set the VBW > RBW.

Detector = Peak.

Trace mode = max hold.

X dB Bandwidth: 26 dB

Measure the maximum width of the emission that is 26 dB down from the maximum of the emission.

Compare this with the RBW setting of the analyzer. Readjust RBW and repeat measurement as needed until the RBW/EBW ratio is approximately 1%.

■ Minimum Emission Bandwidth for the UNII Band III

Center Frequency: test Frequency

Set RBW = 100 kHz

Set VBW $\geq 3 \cdot$ RBW

Detector = Peak

Trace mode = max hold

Sweep = auto couple

X dB Bandwidth: 6 dB

Note: The automatic bandwidth measurement capability of a spectrum analyzer or EMI receiver may be employed if it implements the functionality described above.

■ The following procedure shall be used for measuring (99 %) power bandwidth:

Set center frequency to the nominal EUT channel center frequency.

Set span = 1.5 times to 5.0 times the OBW.

Set RBW = 1 % to 5 % of the OBW

Set VBW $\geq 3 \cdot$ RBW

Video averaging is not permitted. Where practical, a sample detection and single sweep mode shall be used. Otherwise, peak detection and max hold mode (until the trace stabilizes) shall be used.

Use the 99 % power bandwidth function of the instrument (if available).

If the instrument does not have a 99 % power bandwidth function, the trace data points are recovered and directly summed in power units. The recovered amplitude data points, beginning at the lowest frequency, are placed in a running sum until 0.5 % of the total is reached; that frequency is recorded as the lower frequency. The process is repeated until 99.5 % of the total is reached; that frequency is recorded as the upper frequency. The 99% occupied bandwidth is the difference between these two frequencies.

8.1.5 Test Results

		<input checked="" type="checkbox"/> 802.11a mode	
Temperature :	28	Test Date :	February 07, 2018
Humidity :	65 %	Test By:	King Kong

Band	Channel Number	Channel Freq. (MHz)	26dB EBW		99% OBW		Limit (MHz)	Verdict
			Ant0	Ant1	Ant0	Ant1		
UNII Band I	CH36	5180	21.63	21.48	16.820	16.783	N/A	N/A
	CH40	5200	21.51	21.48	16.785	16.773	N/A	N/A
	CH48	5240	21.38	21.39	16.792	16.755	N/A	N/A
UNII Band II-A	CH52	5260	21.55	21.52	16.792	16.819	N/A	N/A
	CH56	5280	21.55	21.46	16.782	16.780	N/A	N/A
	CH64	5320	21.51	21.53	16.783	16.805	N/A	N/A
UNII Band II-C	CH100	5500	21.48	21.43	16.772	16.782	N/A	N/A
	CH120	5600	21.45	21.53	16.716	16.765	N/A	N/A
	CH140	5700	21.49	21.58	16.804	16.805	N/A	N/A
UNII Band III	CH149	5745	21.48	21.44	16.764	16.790	N/A	N/A
	CH157	5785	21.39	21.44	16.793	16.848	N/A	N/A
	CH165	5825	21.48	21.52	16.827	16.786	N/A	N/A

Note:
N/A (Not Applicable)

		<input checked="" type="checkbox"/> 802.11n(VHT20) mode	
Temperature :	28	Test Date :	February 07, 2018
Humidity :	65 %	Test By:	King Kong

Band	Channel Number	Channel Freq. (MHz)	26dB EBW		99% OBW		Limit (MHz)	Verdict
			Ant0	Ant1	Ant0	Ant1		
UNII Band I	CH36	5180	21.80	21.60	17.927	17.915	N/A	N/A
	CH40	5200	21.89	21.80	17.916	17.896	N/A	N/A
	CH48	5240	21.67	21.71	17.940	17.896	N/A	N/A
UNII Band II-A	CH52	5260	21.91	21.80	17.879	17.931	N/A	N/A
	CH56	5280	21.76	21.88	17.893	17.918	N/A	N/A
	CH64	5320	21.50	21.55	17.915	17.915	N/A	N/A
UNII Band II-C	CH100	5500	21.55	21.89	17.893	17.893	N/A	N/A
	CH120	5600	21.54	21.78	17.898	17.882	N/A	N/A
	CH140	5700	21.65	21.74	17.909	17.961	N/A	N/A
UNII Band III	CH149	5745	21.52	21.78	17.915	17.909	N/A	N/A
	CH157	5785	21.48	21.77	17.912	17.916	N/A	N/A
	CH165	5825	21.60	21.92	17.934	17.967	N/A	N/A

Note:
N/A (Not Applicable)

☒ 802.11ac(VHT20) mode								
Temperature :		28	Test Date :		February 07, 2018			
Humidity :		65 %	Test By:		King Kong			
Band	Channel Number	Channel Freq. (MHz)	26dB EBW		99% OBW		Limit (MHz)	Verdict
			Ant0	Ant1	Ant0	Ant1		
UNII Band I	CH36	5180	21.50	21.31	17.792	17.761	N/A	N/A
	CH40	5200	21.18	21.32	17.814	17.818	N/A	N/A
	CH48	5240	21.26	21.33	17.809	17.791	N/A	N/A
UNII Band II-A	CH52	5260	21.40	21.20	17.792	17.802	N/A	N/A
	CH56	5280	21.38	21.26	17.812	17.785	N/A	N/A
	CH64	5320	21.09	21.16	17.763	17.804	N/A	N/A
UNII Band II-C	CH100	5500	21.37	21.01	17.790	17.775	N/A	N/A
	CH120	5600	21.38	21.27	17.878	17.789	N/A	N/A
	CH140	5700	21.43	21.52	17.814	17.790	N/A	N/A
UNII Band III	CH149	5745	21.29	21.18	17.806	17.793	N/A	N/A
	CH157	5785	21.29	21.34	17.829	17.799	N/A	N/A
	CH165	5825	21.15	21.21	17.814	17.833	N/A	N/A
Note: N/A (Not Applicable)								

☒ 802.11n(VHT40) mode								
Temperature :		28	Test Date :		February 07, 2018			
Humidity :		65 %	Test By:		King Kong			
Band	Channel Number	Channel Freq. (MHz)	26dB EBW		99% OBW		Limit (MHz)	Verdict
			Ant0	Ant1	Ant0	Ant1		
UNII Band I	CH38	5190	40.32	40.40	36.447	36.490	N/A	N/A
	CH46	5230	40.13	40.04	36.470	36.437	N/A	N/A
UNII Band II-A	CH54	5270	40.11	40.17	36.430	36.438	N/A	N/A
	CH62	5310	40.07	40.34	36.433	36.444	N/A	N/A
UNII Band II-C	CH102	5510	40.33	40.07	36.386	36.397	N/A	N/A
	CH118	5590	40.21	40.16	36.444	36.412	N/A	N/A
	CH134	5670	40.13	40.05	36.417	36.399	N/A	N/A
UNII Band III	CH151	5755	40.20	40.17	36.408	36.482	N/A	N/A
	CH159	5795	39.98	40.27	36.527	36.510	N/A	N/A
Note: N/A (Not Applicable)								

☒ 802.11ac(VHT40) mode								
Temperature :		28	Test Date :		February 07, 2018			
Humidity :		65 %	Test By:		King Kong			
Band	Channel Number	Channel Freq. (MHz)	26dB EBW		99% OBW		Limit (MHz)	Verdict
			Ant0	Ant1	Ant0	Ant1		
UNII Band I	CH38	5190	39.64	39.86	36.451	36.406	N/A	N/A
	CH46	5230	39.70	40.04	36.310	36.458	N/A	N/A
UNII Band II-A	CH54	5270	39.97	39.77	36.468	36.392	N/A	N/A
	CH62	5310	39.76	39.77	36.405	36.413	N/A	N/A
UNII Band II-C	CH102	5510	39.49	39.51	36.398	36.346	N/A	N/A
	CH118	5590	39.51	39.98	39.343	36.407	N/A	N/A
	CH134	5670	39.57	39.80	36.391	36.441	N/A	N/A
UNII Band III	CH151	5755	39.81	40.23	36.360	36.411	N/A	N/A
	CH159	5795	39.73	40.06	36.518	36.525	N/A	N/A
Note: N/A (Not Applicable)								

<input checked="" type="checkbox"/> 802.11ac(VHT80) mode			
Temperature :	28	Test Date :	February 07, 2018
Humidity :	65 %	Test By:	King Kong

Band	Channel Number	Channel Freq. (MHz)	26dB EBW		99% OBW		Limit (MHz)	Verdict
			Ant0	Ant1	Ant0	Ant1		
UNII Band I	CH42	5210	81.70	81.43	76.038	75.940	N/A	N/A
UNII Band II-A	CH58	5290	81.38	81.66	75.946	75.969	N/A	N/A
UNII Band II-C	CH106	5530	81.68	81.66	76.140	75.969	N/A	N/A
	CH122	5610	80.87	81.57	75.990	76.124	N/A	N/A
UNII Band III	CH155	5775	81.09	81.55	75.870	75.931	N/A	N/A

Note:
N/A (Not Applicable)

<input checked="" type="checkbox"/> UNII Band III			
Temperature :	28	Test Date :	February 07, 2018
Humidity :	65 %	Test By:	King Kong

Operation Mode	Channel Number	Channel Freq. (MHz)	6dB EBW		Limit (kHz)	Verdict
			Ant0	Ant1		
802.11a	CH149	5745	16.41	16.41	500	PASS
	CH157	5785	16.42	16.42	500	PASS
	CH165	5825	16.41	16.42	500	PASS
802.11n (VHT20)	CH149	5745	17.61	17.61	500	PASS
	CH157	5785	17.62	17.61	500	PASS
	CH165	5825	17.63	17.64	500	PASS
802.11ac (VHT20)	CH149	5745	17.71	17.74	500	PASS
	CH157	5785	17.75	17.73	500	PASS
	CH165	5825	17.75	17.72	500	PASS
802.11n (VHT40)	CH151	5755	36.36	36.37	500	PASS
	CH159	5795	36.38	36.17	500	PASS
802.11ac (VHT40)	CH151	5755	36.50	36.49	500	PASS
	CH159	5795	36.52	36.51	500	PASS
802.11ac (VHT80)	CH155	5775	75.82	75.86	500	PASS

Note:
N/A (Not Applicable)

Emission Bandwidth&99% Occupied Bandwidth	UNII Band I
Test Model 802.11a	Frequency(MHz) 5180
Ant0	



Ant1



Emission Bandwidth&99% Occupied Bandwidth	UNII Band I	
Test Model	802.11a	Frequency(MHz)
Ant0		5200



Ant1



Emission Bandwidth&99% Occupied Bandwidth		UNII Band I	
Test Model	802.11a	Frequency(MHz)	5240
Ant0			



Ant1



Emission Bandwidth&99% Occupied Bandwidth		UNII Band II-A	
Test Model	802.11a	Frequency(MHz)	5260
Ant0			

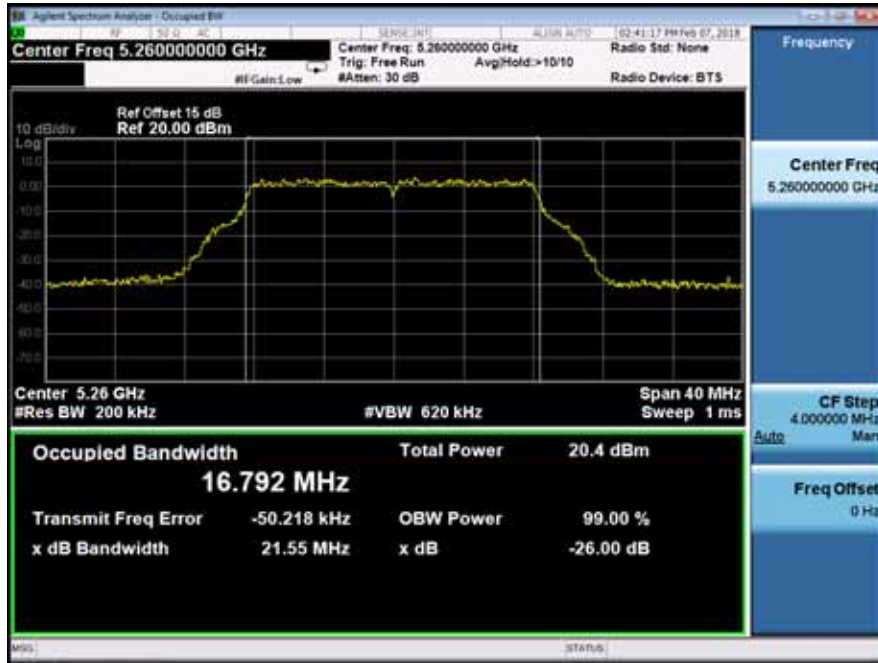

Ant1

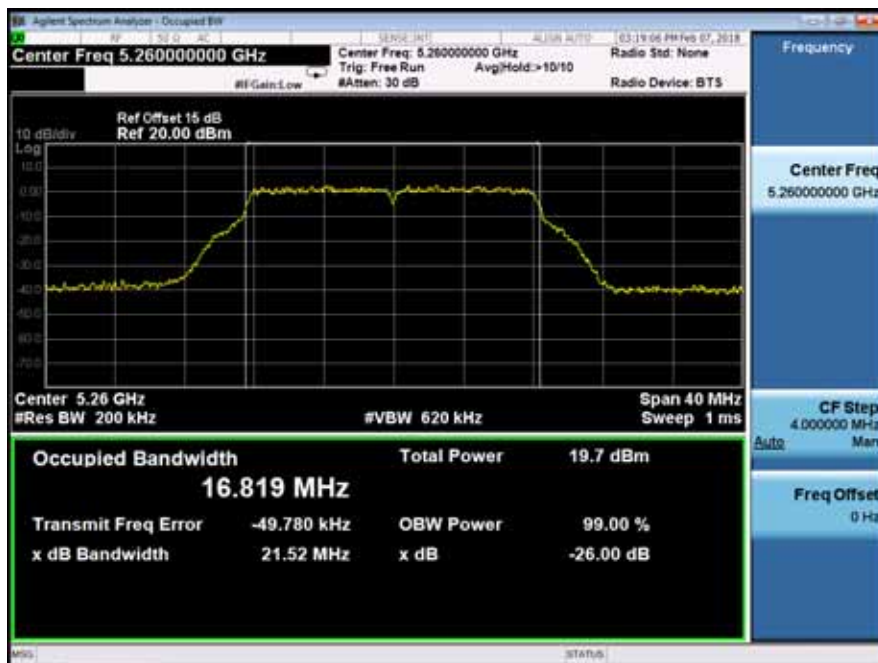

Emission Bandwidth&99% Occupied Bandwidth	UNII Band II-A
Test Model 802.11a	Frequency(MHz) 5280
Ant0	



Ant1

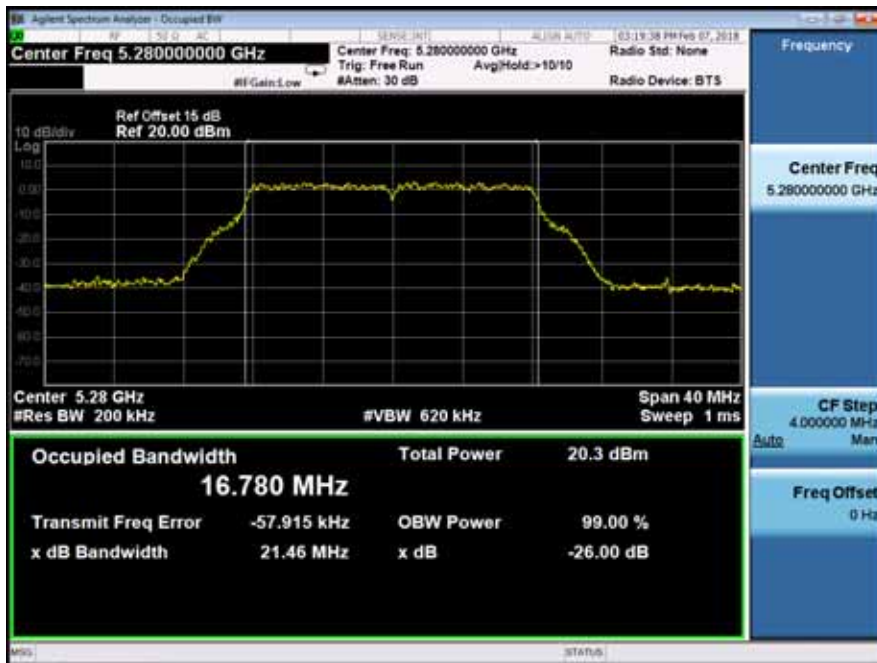

Emission Bandwidth&99% Occupied Bandwidth	UNII Band II-A
Test Model 802.11a	Frequency(MHz) 5320
Ant0	



Ant1



Emission Bandwidth&99% Occupied Bandwidth	UNII Band II-C
Test Model 802.11a	Frequency(MHz) 5500
Ant0	



Ant1

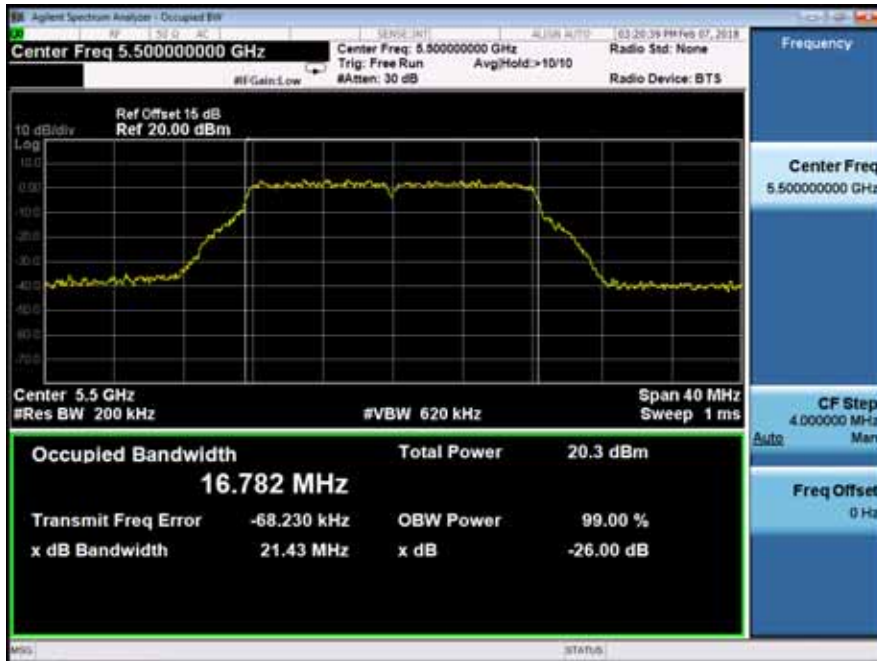

Emission Bandwidth&99% Occupied Bandwidth	UNII Band II-C
Test Model 802.11a	Frequency(MHz) 5600
Ant0	



Ant1



Emission Bandwidth&99% Occupied Bandwidth	UNII Band II-C
Test Model 802.11a	Frequency(MHz) 5700
Ant0	



Ant1



Emission Bandwidth&99% Occupied Bandwidth	UNII Band III
Test Model 802.11a	Frequency(MHz) 5745
Ant0	



Ant1



Emission Bandwidth&99% Occupied Bandwidth	UNII Band III
Test Model 802.11a	Frequency(MHz) 5785
Ant0	



Ant1



Emission Bandwidth&99% Occupied Bandwidth	UNII Band III
Test Model 802.11a	Frequency(MHz) 5825

Ant0



Ant1



Emission Bandwidth&99% Occupied Bandwidth	UNII Band I
Test Model 802.11n(VHT20) mode	Frequency(MHz) 5180
Ant0	



Ant1



Emission Bandwidth&99% Occupied Bandwidth	UNII Band I
Test Model 802.11n(VHT20) mode	Frequency(MHz) 5200
Ant0	



Ant1

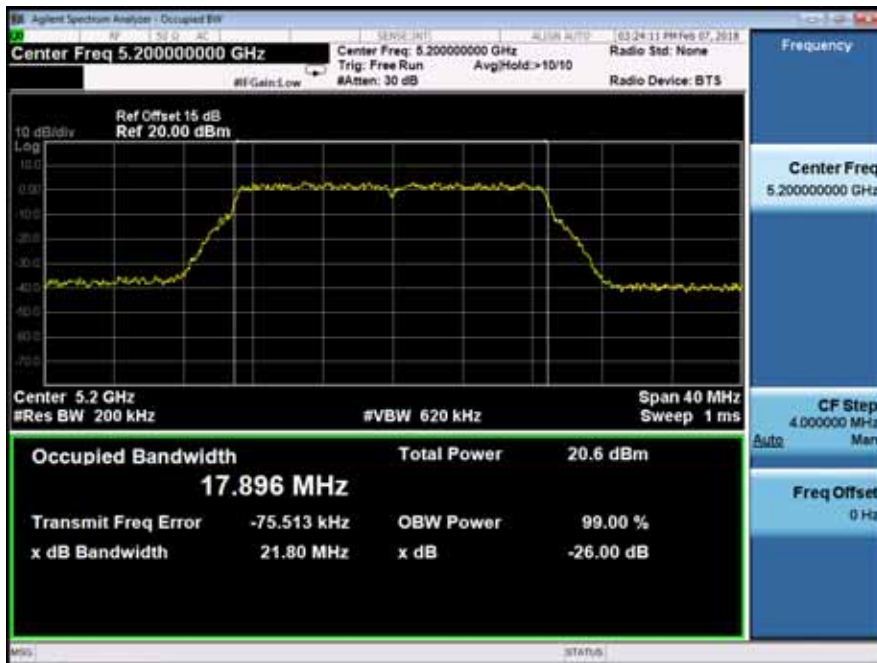

Emission Bandwidth&99% Occupied Bandwidth	UNII Band I
Test Model 802.11n(VHT20) mode	Frequency(MHz) 5240
Ant0	



Ant1

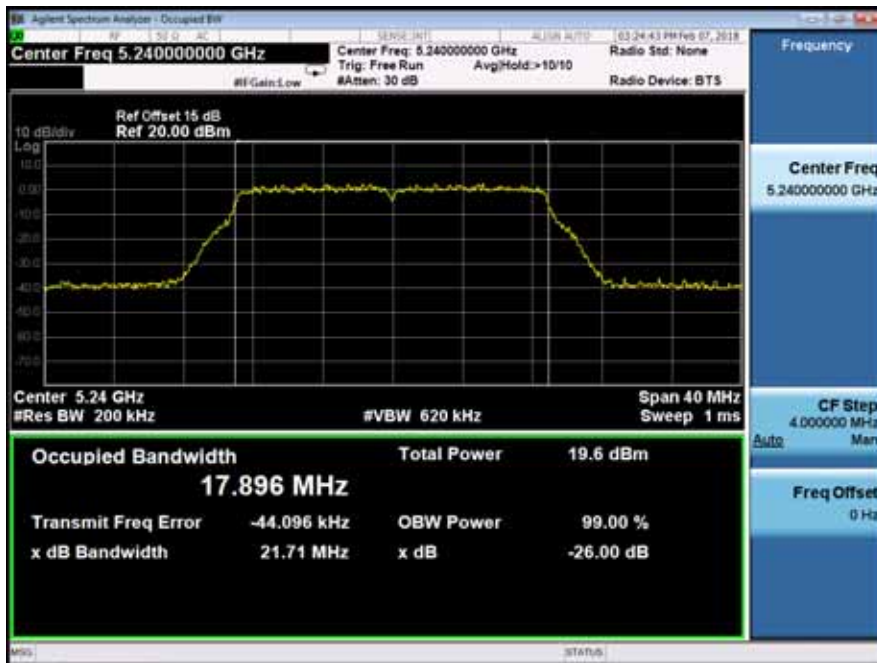

Emission Bandwidth&99% Occupied Bandwidth	UNII Band II-A
Test Model 802.11n(VHT20) mode	Frequency(MHz) 5260
Ant0	



Ant1

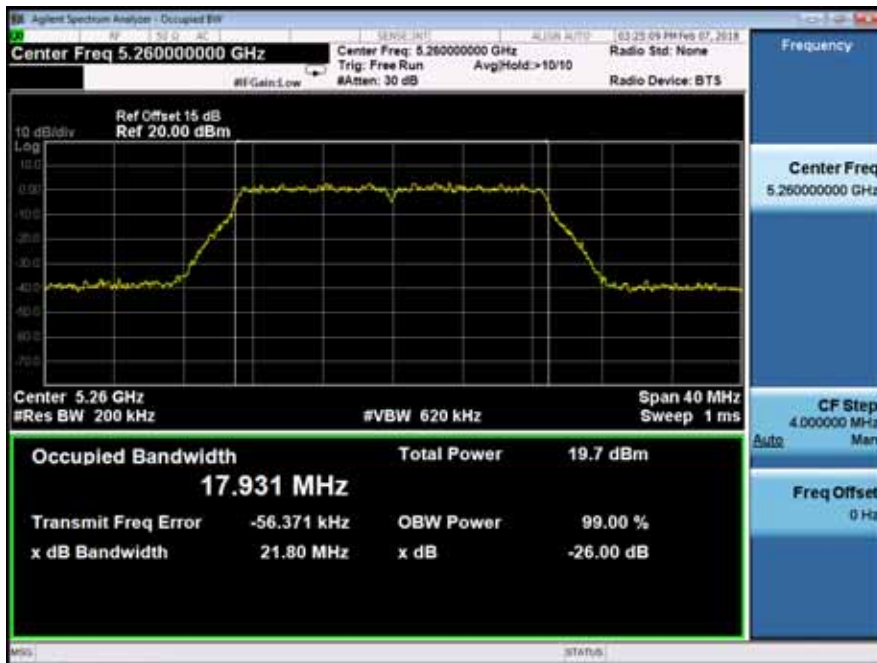

Emission Bandwidth&99% Occupied Bandwidth	UNII Band II-A
Test Model 802.11n(VHT20) mode	Frequency(MHz) 5280
Ant0	



Ant1

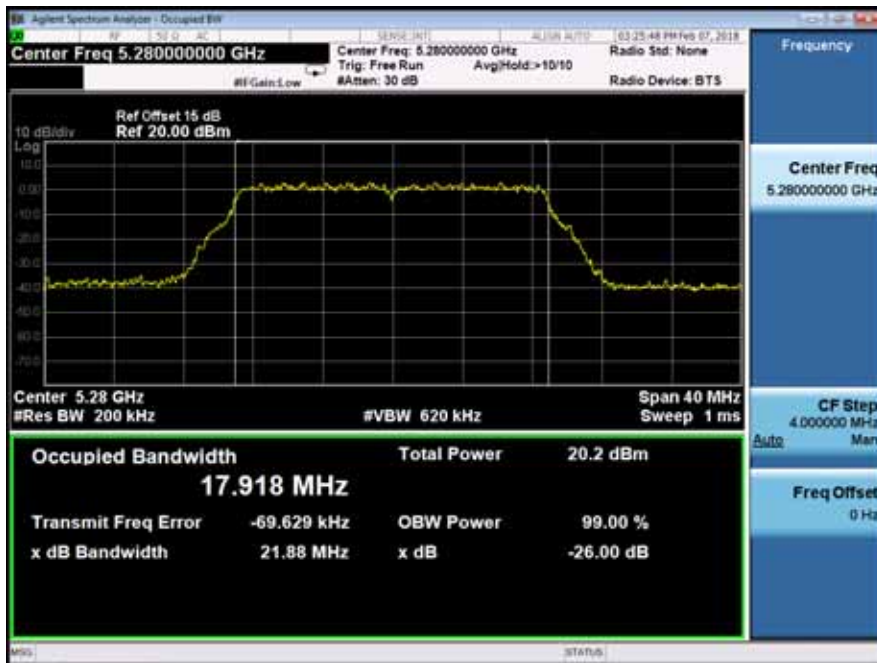

Emission Bandwidth&99% Occupied Bandwidth	UNII Band II-A
Test Model 802.11n(VHT20) mode	Frequency(MHz) 5320
Ant0	



Ant1



Emission Bandwidth&99% Occupied Bandwidth	UNII Band II-C
Test Model 802.11n(VHT20) mode	Frequency(MHz) 5500
Ant0	



Ant1



Emission Bandwidth&99% Occupied Bandwidth	UNII Band II-C
Test Model 802.11n(VHT20) mode	Frequency(MHz) 5600
Ant0	



Ant1



Emission Bandwidth&99% Occupied Bandwidth	UNII Band II-C
Test Model 802.11n(VHT20) mode	Frequency(MHz) 5700
Ant0	



Ant1

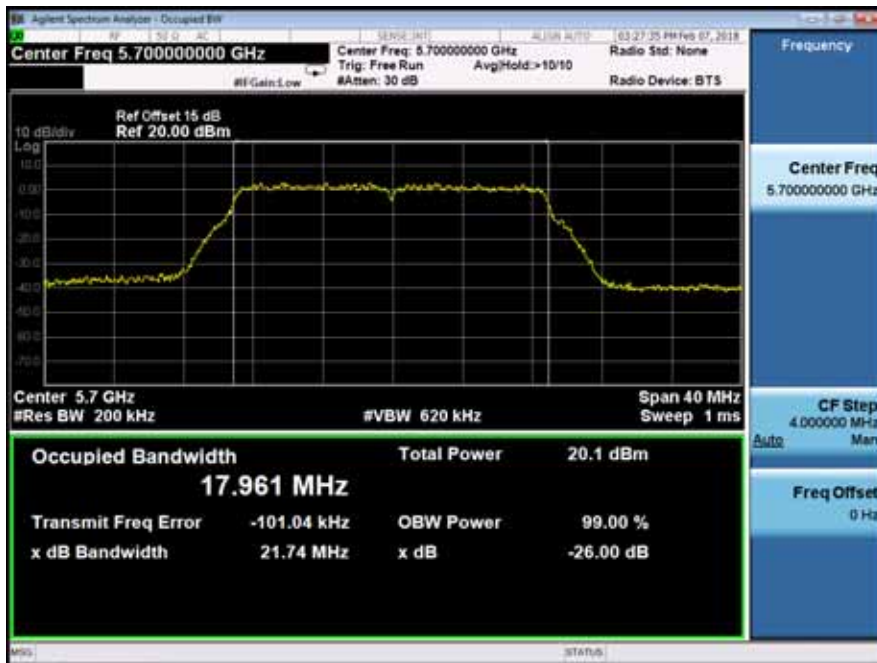

Emission Bandwidth&99% Occupied Bandwidth	UNII Band III
Test Model 802.11n(VHT20) mode	Frequency(MHz) 5745
Ant0	



Ant1

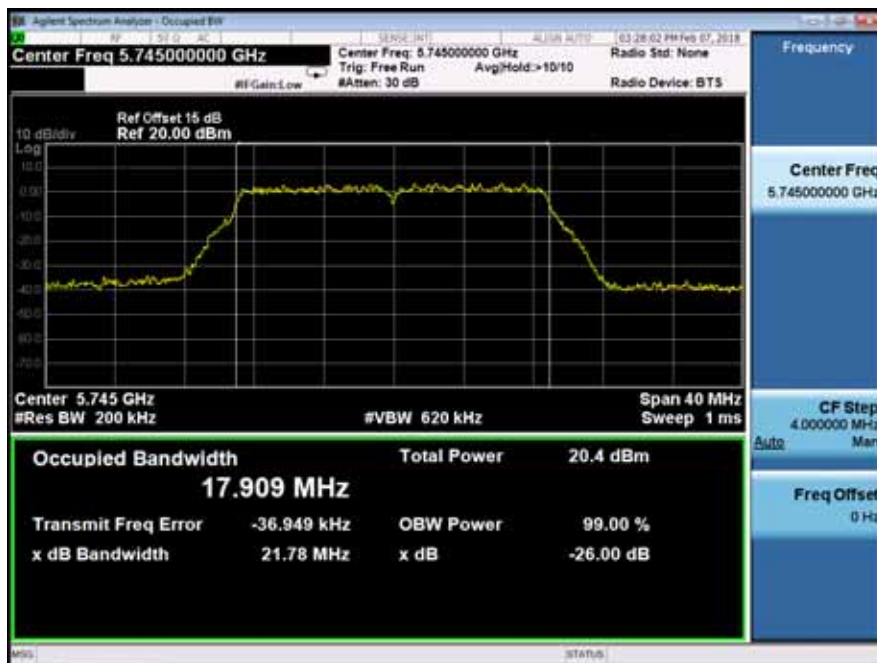

Emission Bandwidth&99% Occupied Bandwidth	UNII Band III
Test Model 802.11n(VHT20) mode	Frequency(MHz) 5785
Ant0	



Ant1

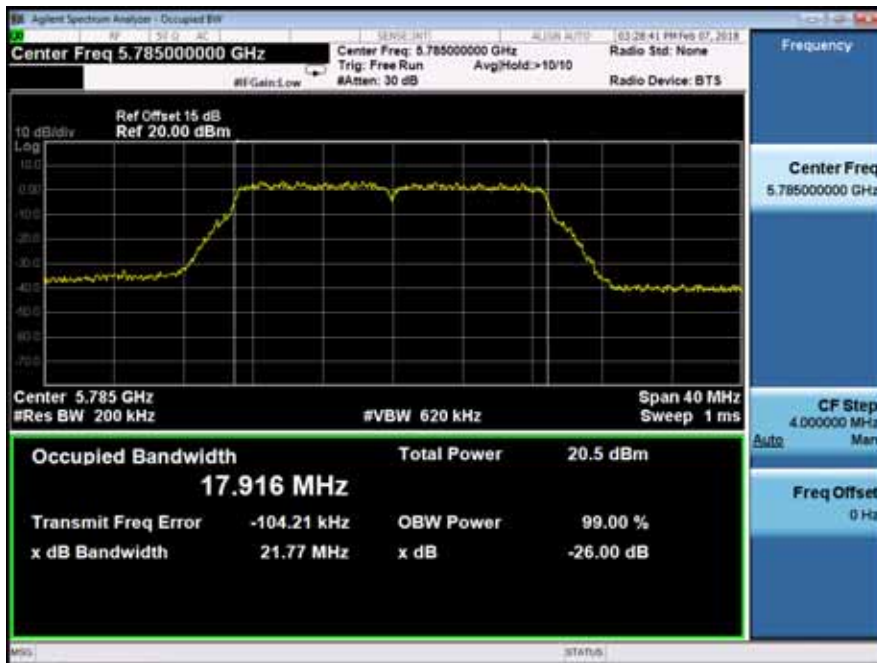

Emission Bandwidth&99% Occupied Bandwidth	UNII Band III
Test Model 802.11n(VHT20) mode	Frequency(MHz) 5825

Ant0



Ant1

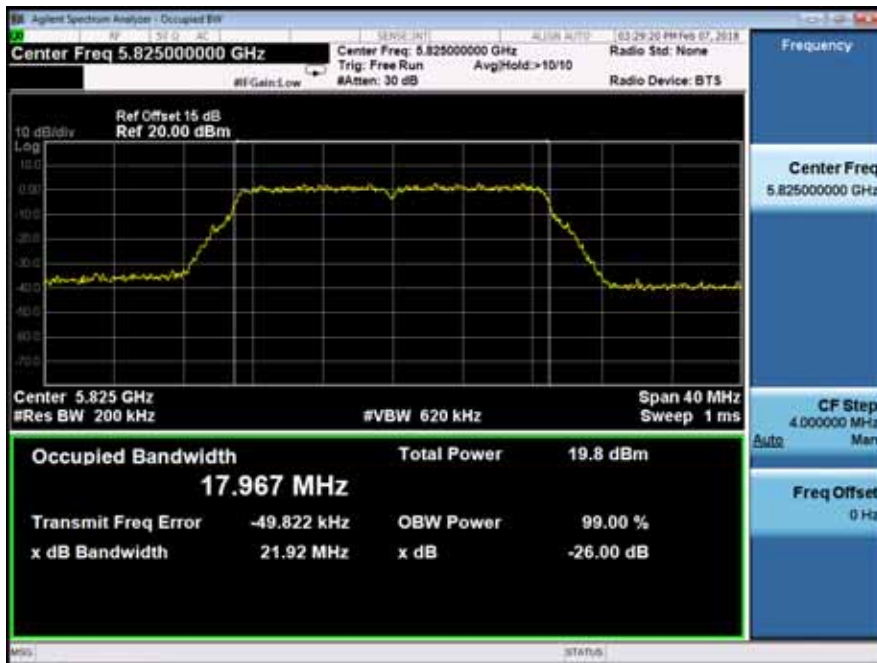

Emission Bandwidth&99% Occupied Bandwidth	UNII Band I
Test Model 802.11ac(VHT20) mode	Frequency(MHz) 5180
Ant0	

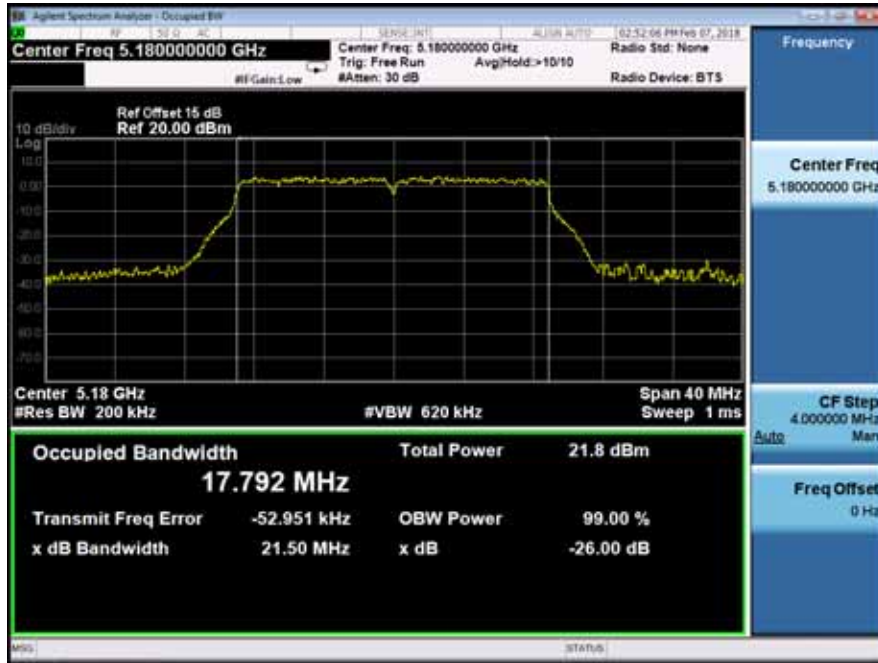

Ant1

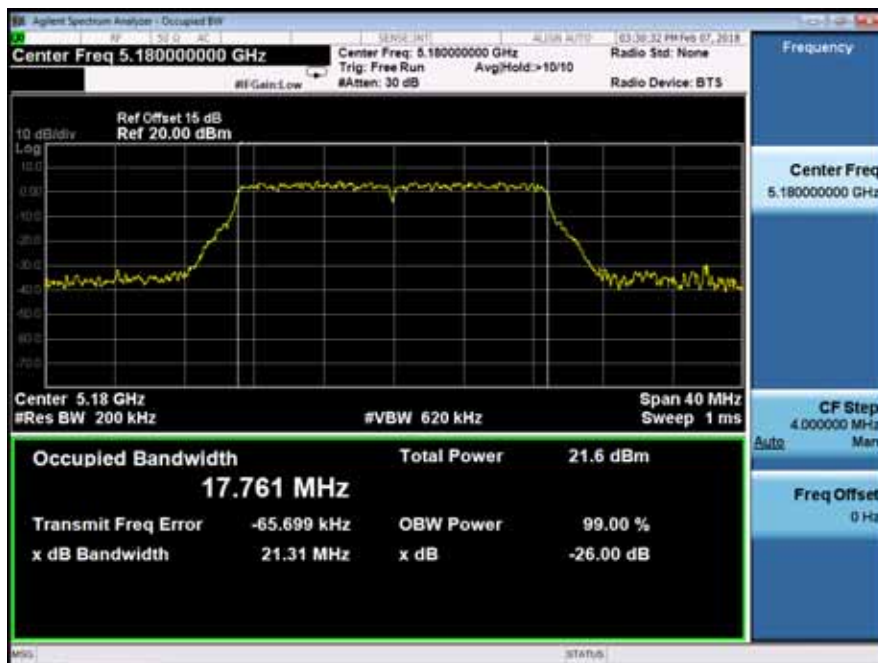

Emission Bandwidth&99% Occupied Bandwidth	UNII Band I
Test Model 802.11ac(VHT20) mode	Frequency(MHz) 5200
Ant0	

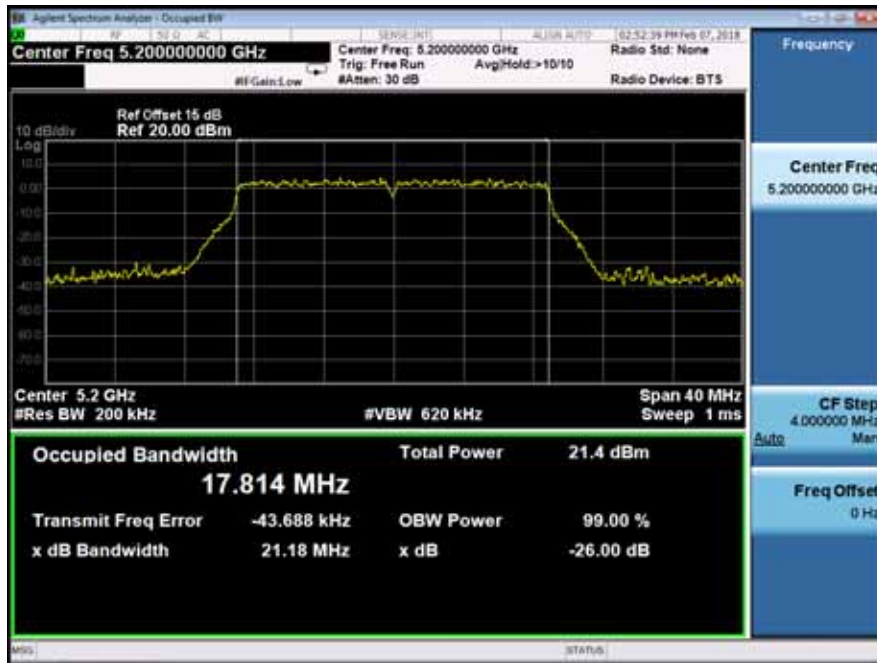

Ant1

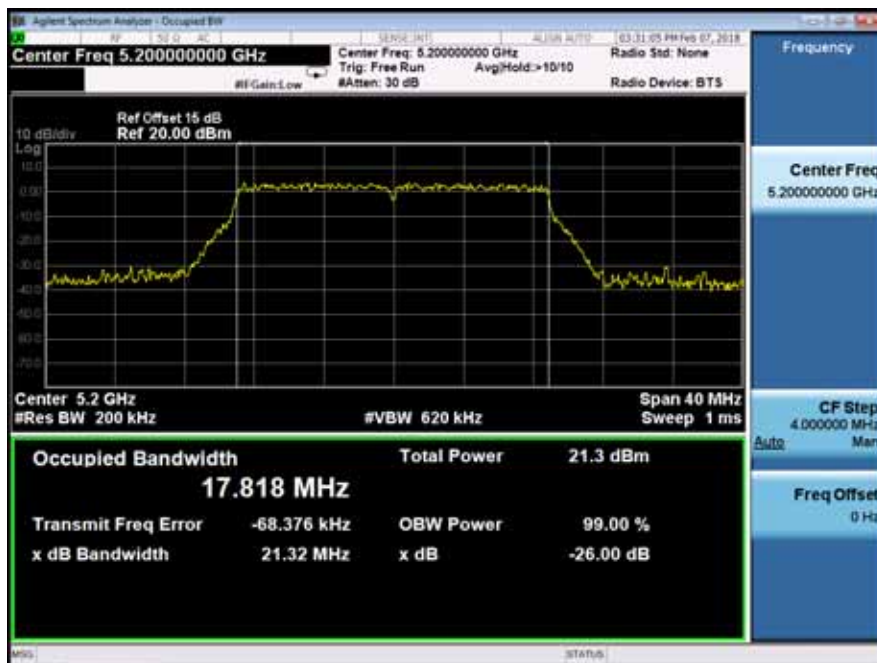

Emission Bandwidth&99% Occupied Bandwidth	UNII Band I
Test Model 802.11ac(VHT20) mode	Frequency(MHz) 5240
Ant0	



Ant1

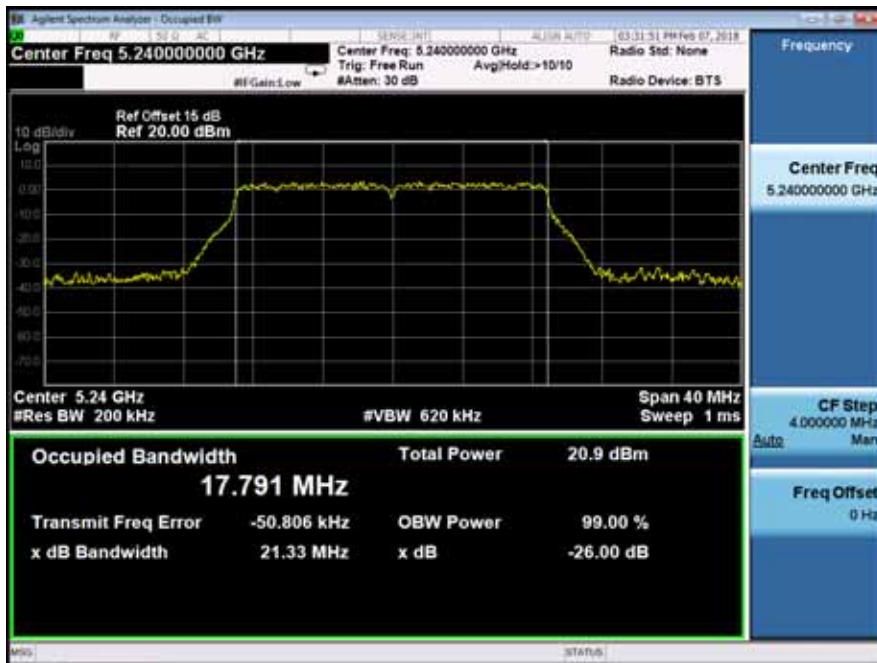

Emission Bandwidth&99% Occupied Bandwidth	UNII Band II-A
Test Model 802.11ac(VHT20) mode	Frequency(MHz) 5260
Ant0	



Ant1

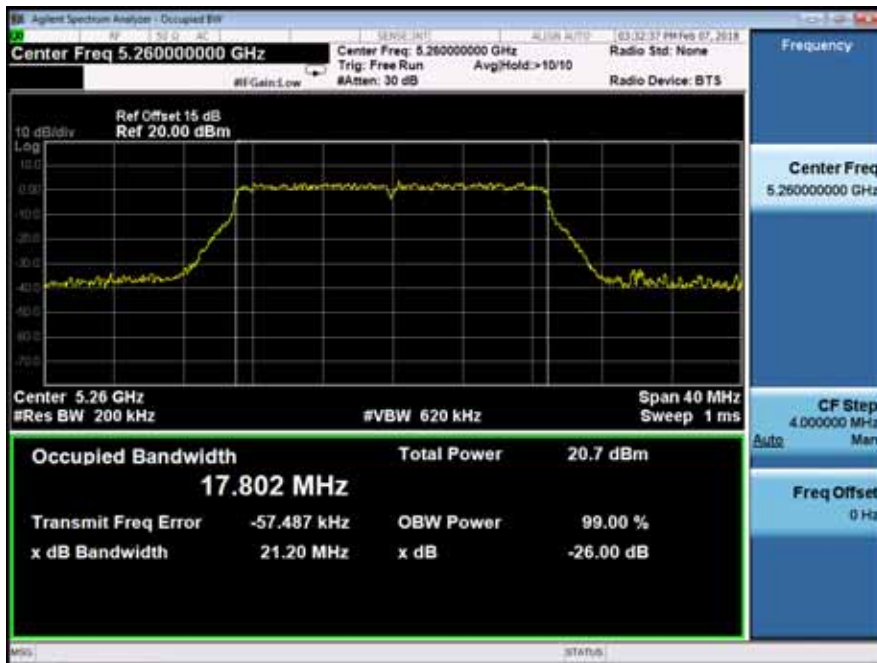

Emission Bandwidth&99% Occupied Bandwidth	UNII Band II-A
Test Model 802.11ac(VHT20) mode	Frequency(MHz) 5280
Ant0	



Ant1

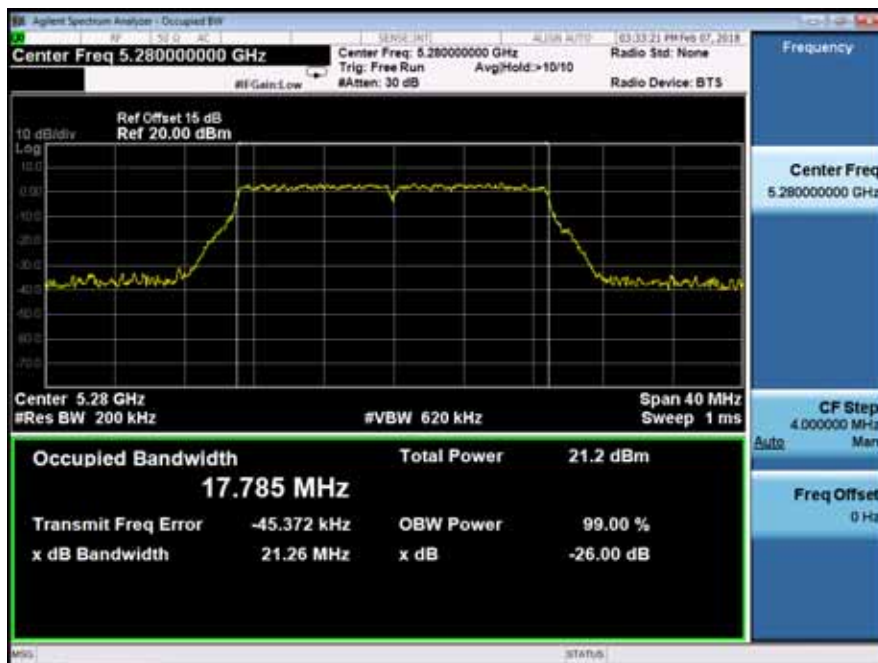

Emission Bandwidth&99% Occupied Bandwidth	UNII Band II-A
Test Model 802.11ac(VHT20) mode	Frequency(MHz) 5320
Ant0	



Ant1

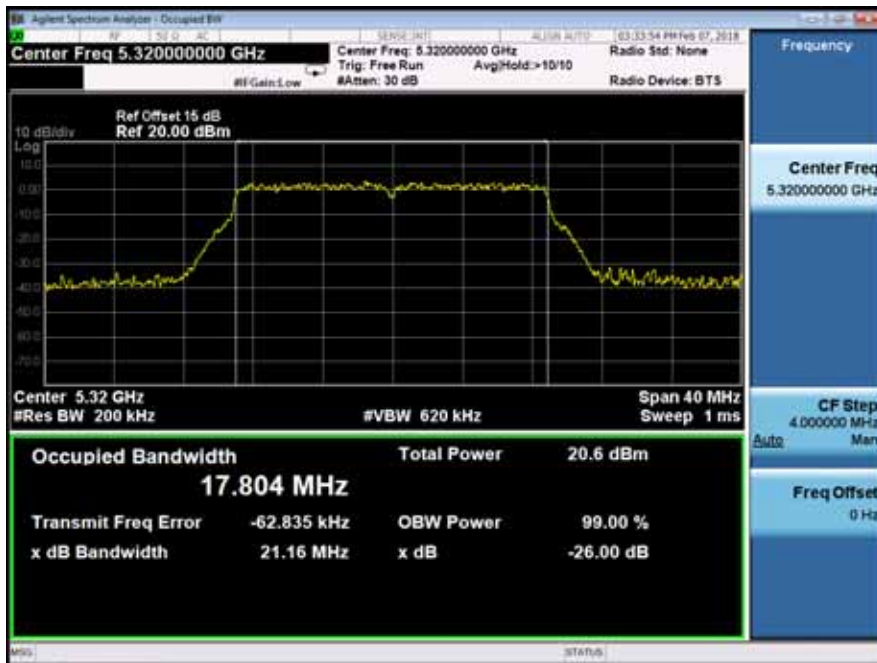

Emission Bandwidth&99% Occupied Bandwidth	UNII Band II-C
Test Model 802.11ac(VHT20) mode	Frequency(MHz) 5500
Ant0	



Ant1

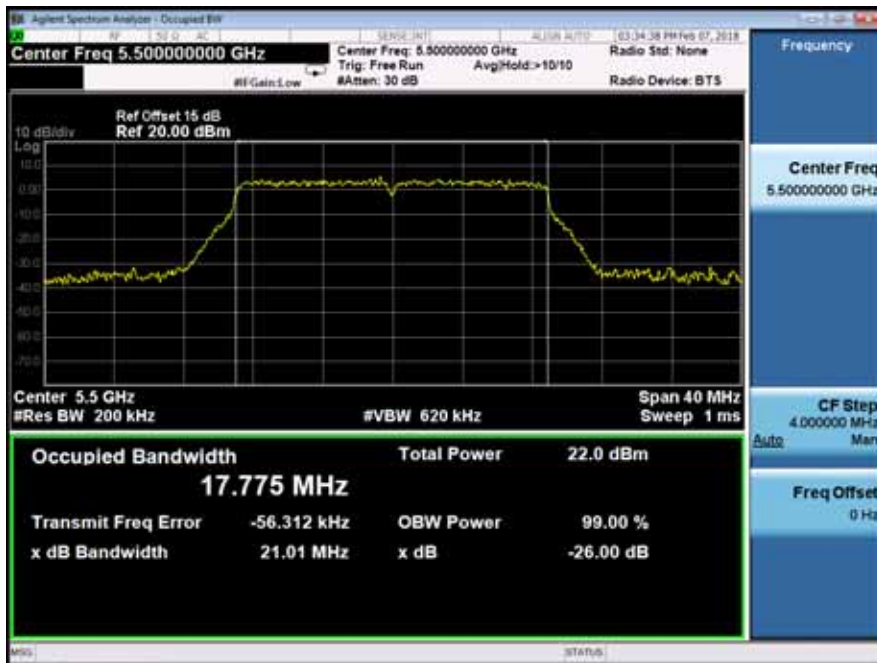

Emission Bandwidth&99% Occupied Bandwidth	UNII Band II-C
Test Model 802.11ac(VHT20) mode	Frequency(MHz) 5600
Ant0	



Ant1

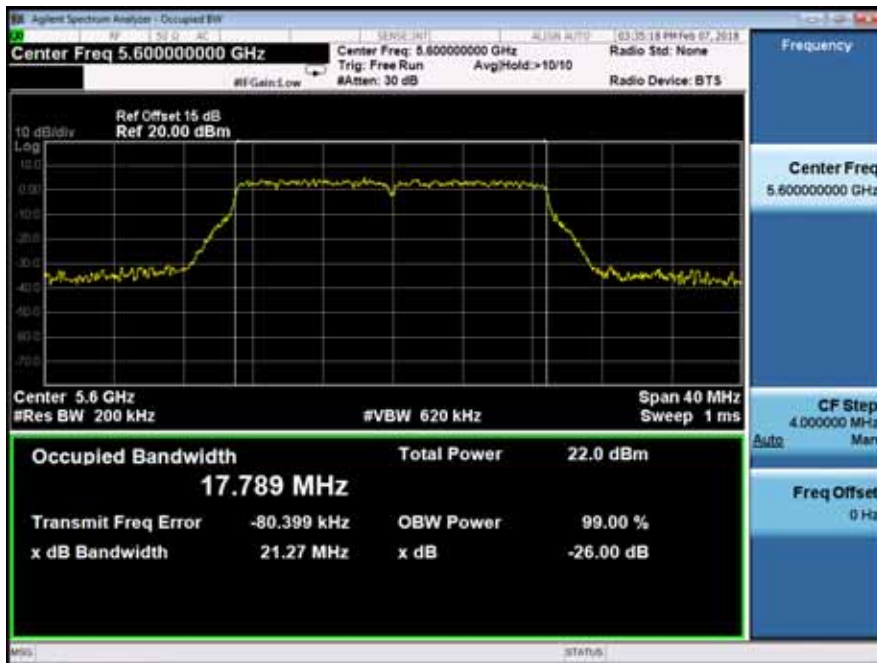

Emission Bandwidth&99% Occupied Bandwidth	UNII Band II-C
Test Model 802.11ac(VHT20) mode	Frequency(MHz) 5700
Ant0	



Ant1

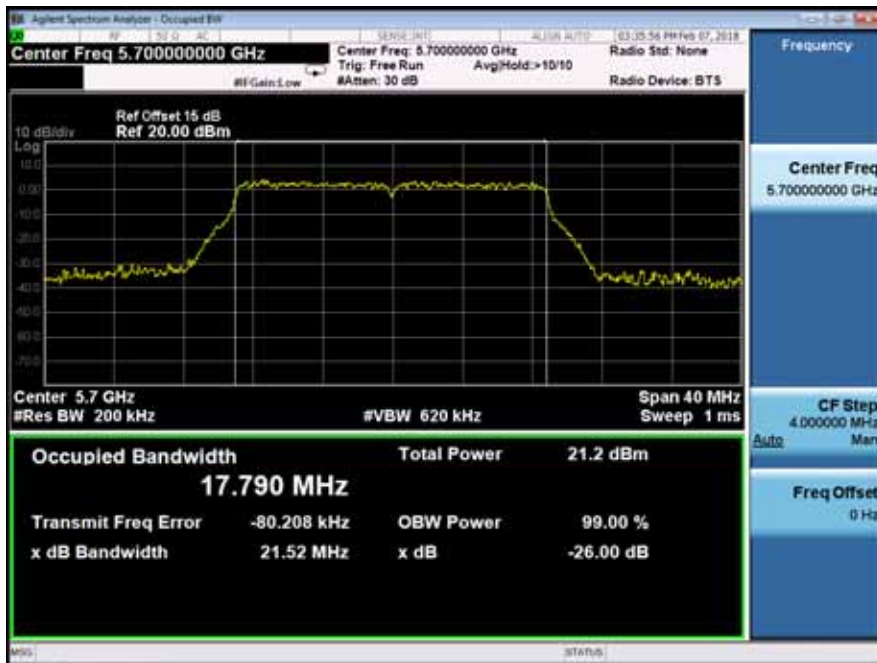

Emission Bandwidth&99% Occupied Bandwidth	UNII Band III
Test Model 802.11ac(VHT20) mode	Frequency(MHz) 5745
Ant0	

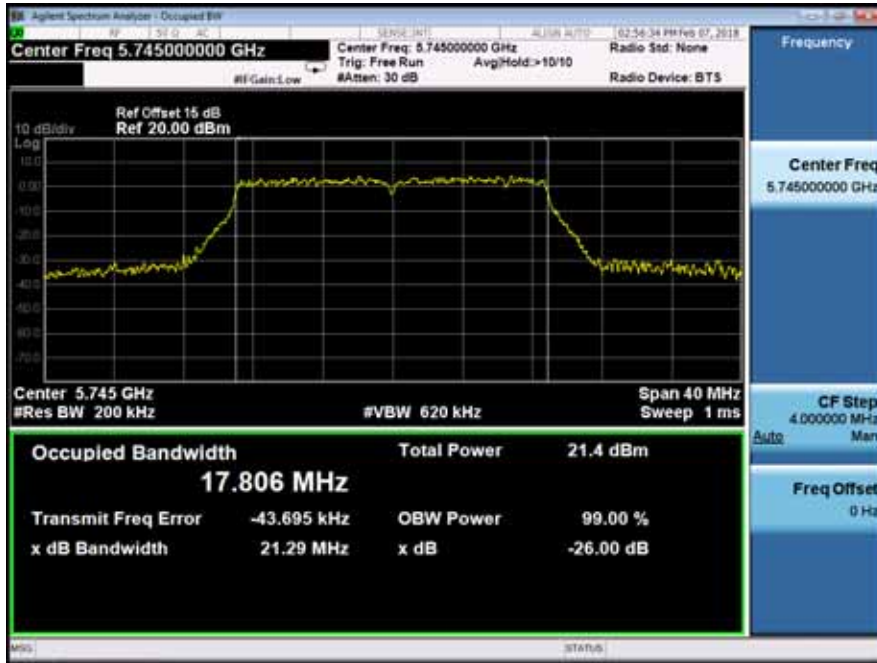

Ant1

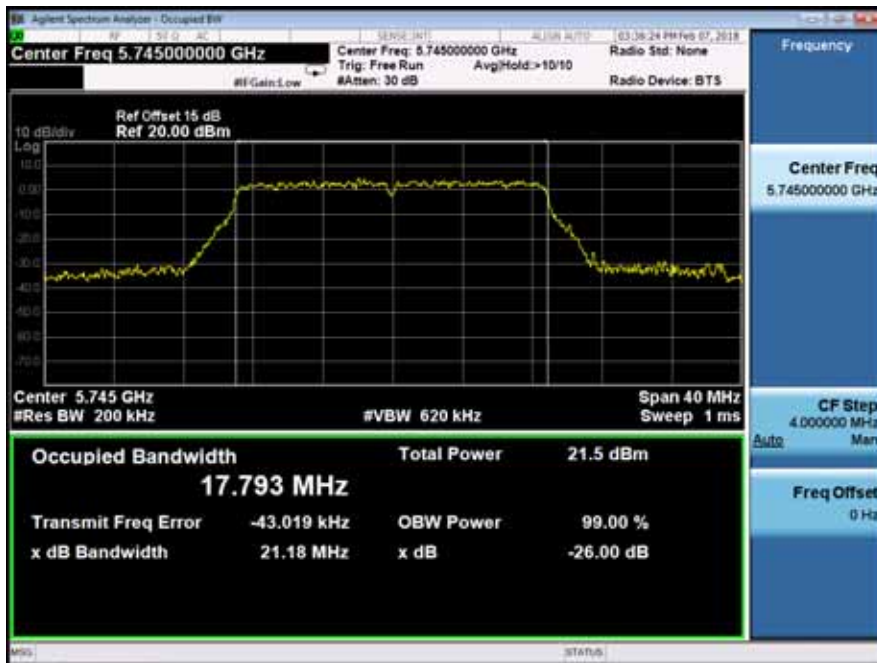

Emission Bandwidth&99% Occupied Bandwidth	UNII Band III
Test Model 802.11ac(VHT20) mode	Frequency(MHz) 5785
Ant0	



Ant1

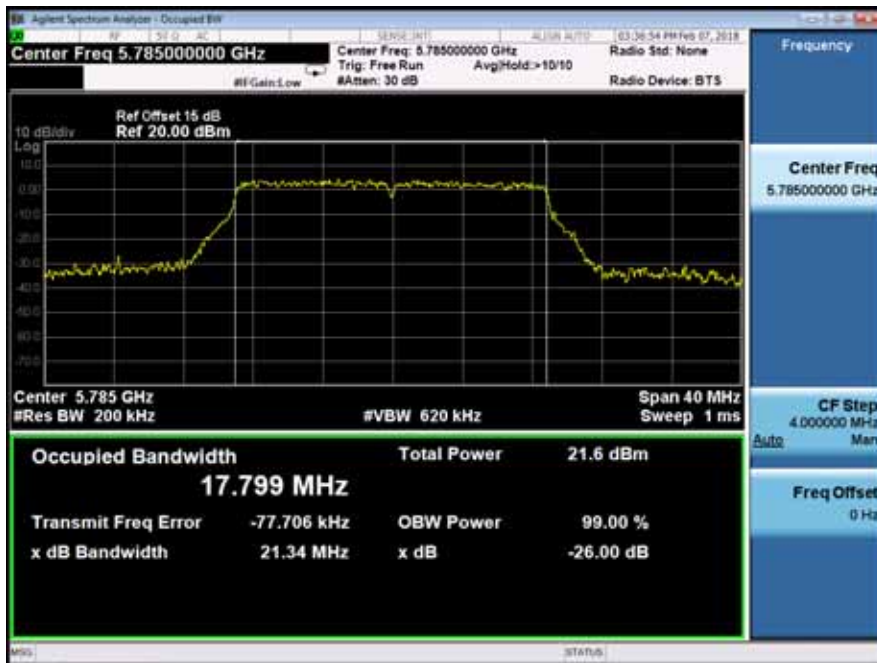

Emission Bandwidth&99% Occupied Bandwidth	UNII Band III
Test Model 802.11ac(VHT20) mode	Frequency(MHz) 5825
Ant0	

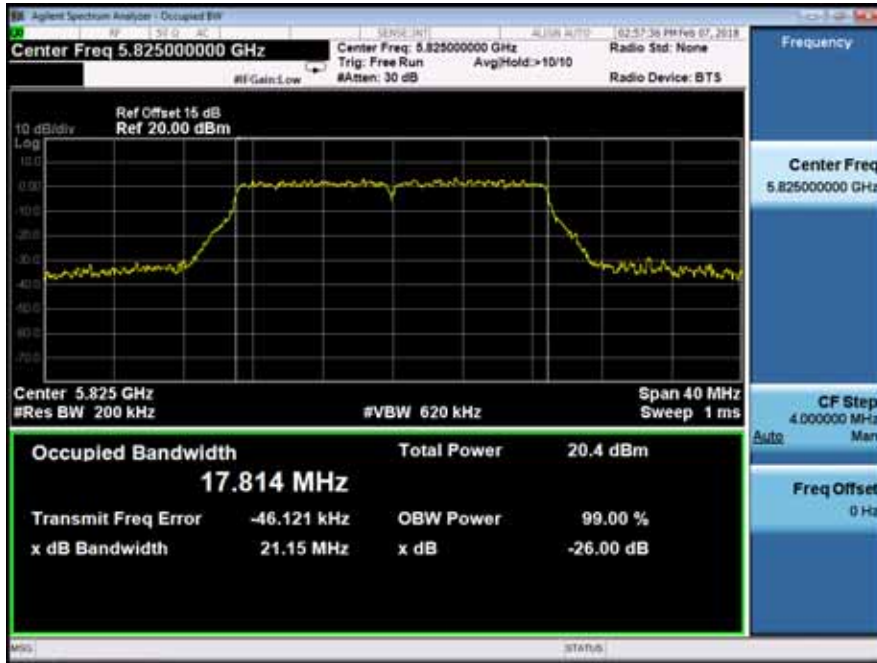

Ant1

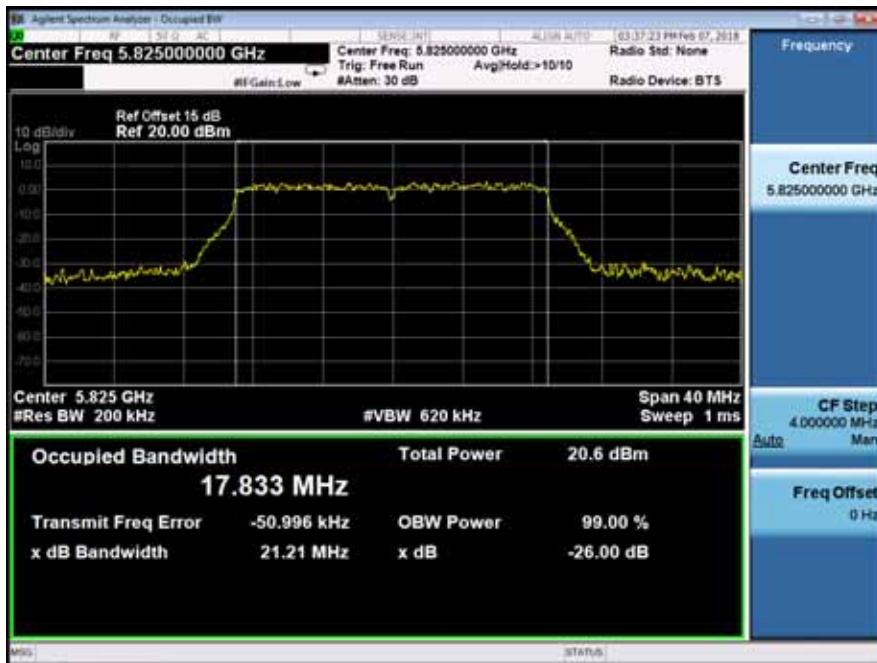

Emission Bandwidth&99% Occupied Bandwidth	UNII Band I
Test Model 802.11n(VHT40) mode	Frequency(MHz) 5190
Ant0	



Ant1

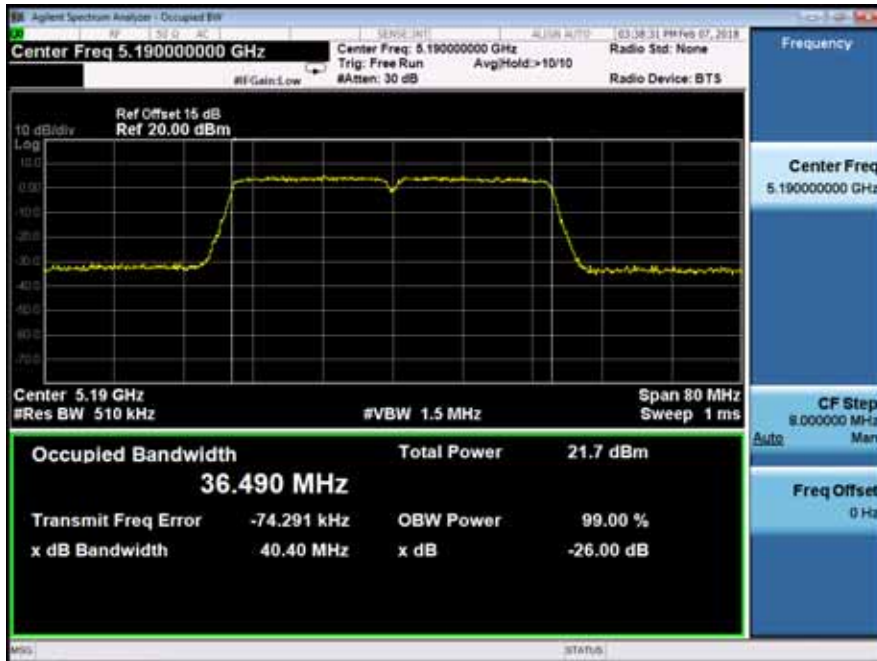

Emission Bandwidth&99% Occupied Bandwidth	UNII Band I
Test Model 802.11n(VHT40) mode	Frequency(MHz) 5230
Ant0	



Ant1

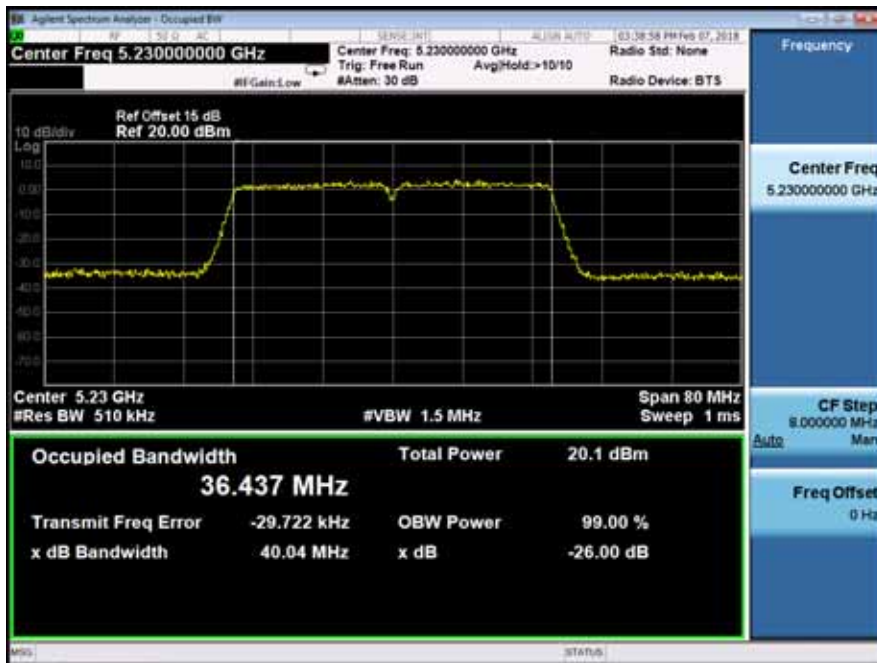

Emission Bandwidth&99% Occupied Bandwidth	UNII Band II-A	
Test Model	802.11n(VHT40) mode	Frequency(MHz)
Ant0		5270



Ant1

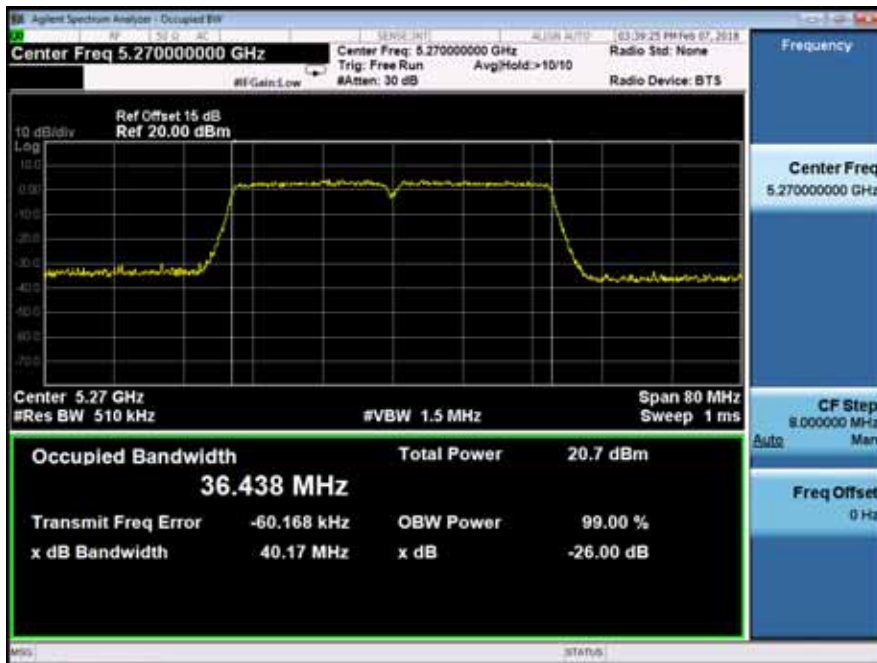

Emission Bandwidth&99% Occupied Bandwidth	UNII Band II-A
Test Model 802.11n(VHT40) mode	Frequency(MHz) 5310
Ant0	



Ant1



Emission Bandwidth&99% Occupied Bandwidth	UNII Band II-C
Test Model 802.11n(VHT40) mode	Frequency(MHz) 5510
Ant0	



Ant1



Emission Bandwidth&99% Occupied Bandwidth	UNII Band II-C
Test Model 802.11n(VHT40) mode	Frequency(MHz) 5590
Ant0	



Ant1

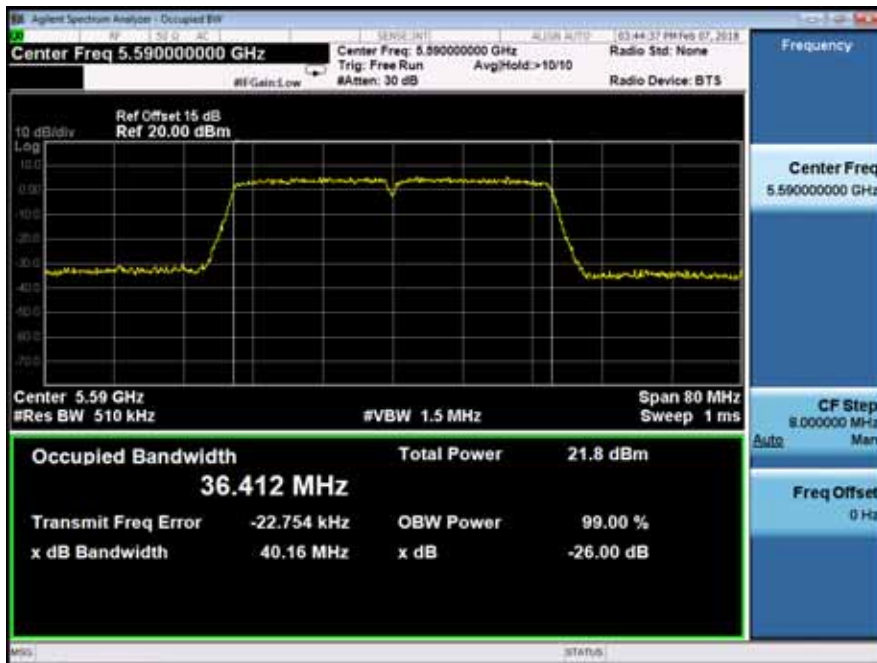

Emission Bandwidth&99% Occupied Bandwidth	UNII Band II-C
Test Model 802.11n(VHT40) mode	Frequency(MHz) 5670
Ant0	

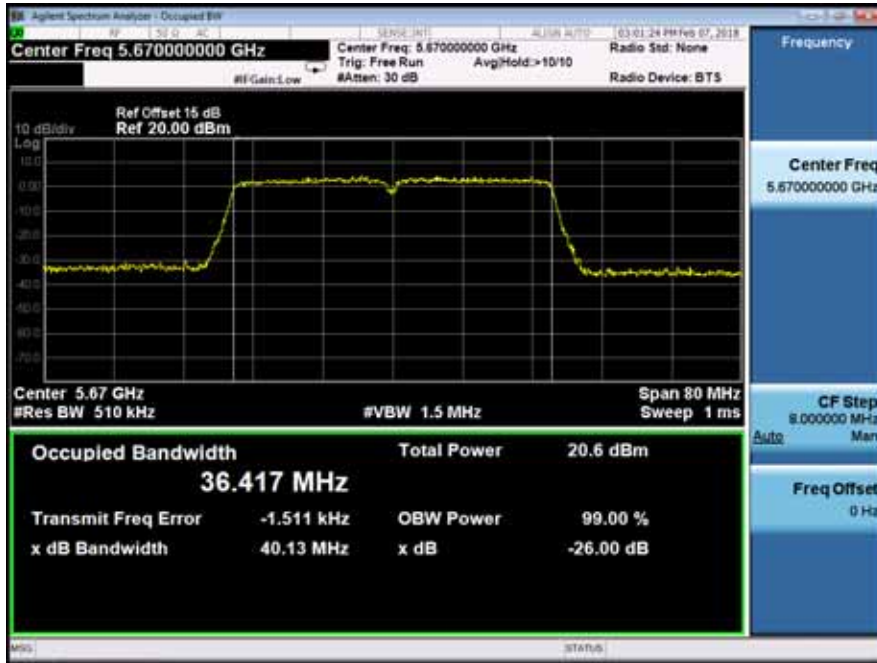

Ant1



Emission Bandwidth&99% Occupied Bandwidth	UNII Band III
Test Model 802.11n(VHT40) mode	Frequency(MHz) 5755
Ant0	



Ant1

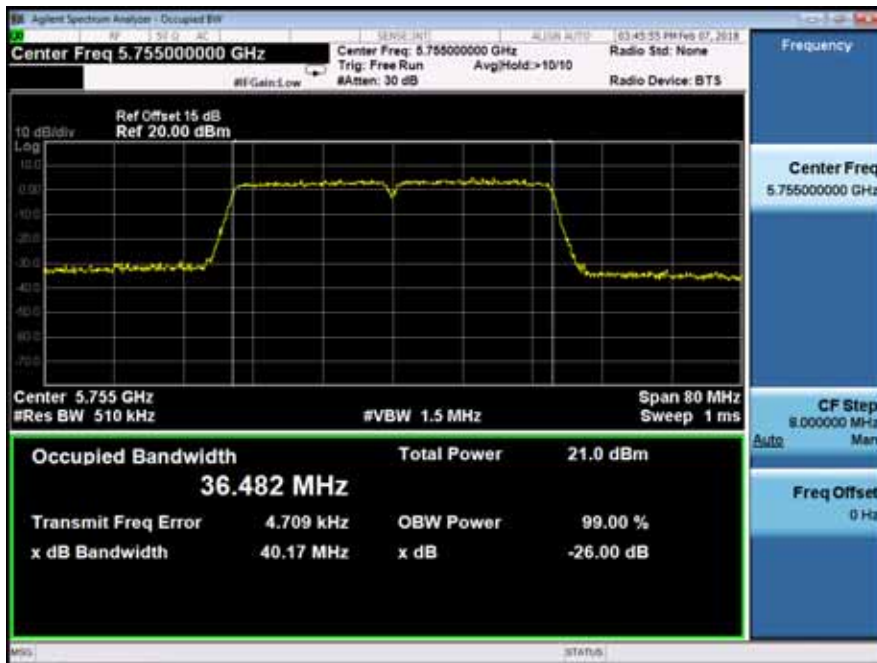

Emission Bandwidth&99% Occupied Bandwidth	UNII Band III	
Test Model	802.11n(VHT40) mode	Frequency(MHz)
Ant0		5795

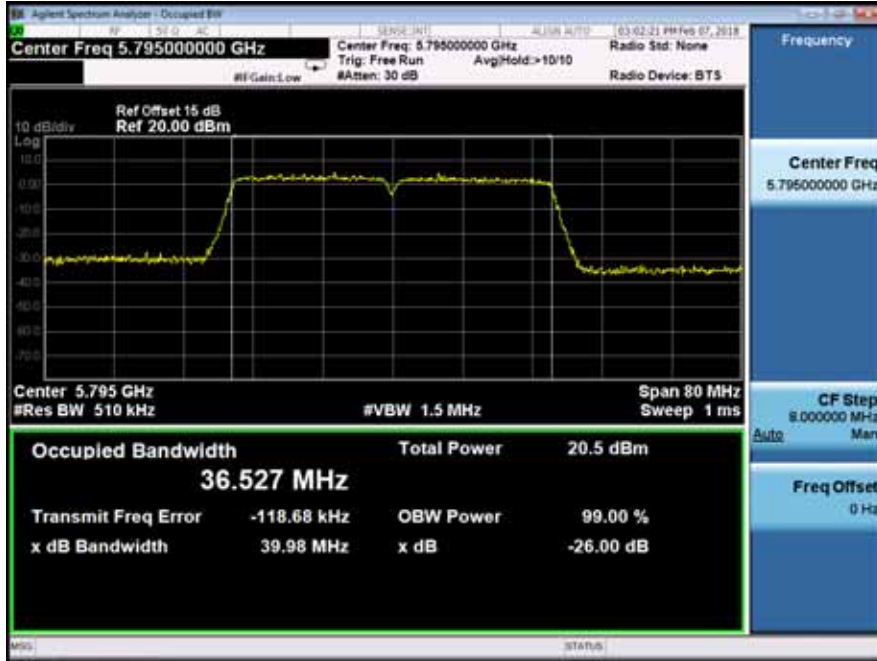

Ant1

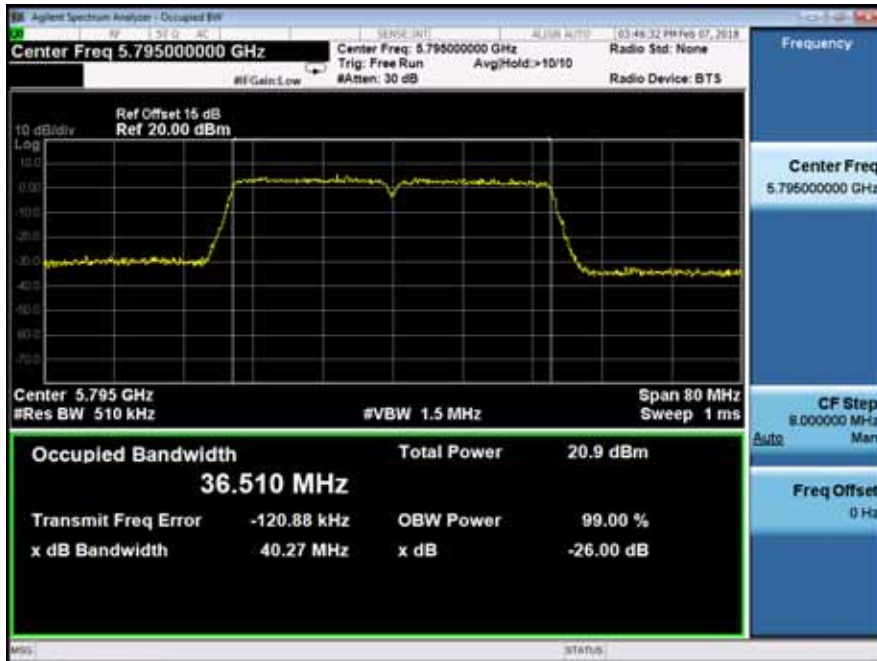

Emission Bandwidth&99% Occupied Bandwidth	UNII Band I
Test Model 802.11ac(VHT40) mode	Frequency(MHz) 5190
Ant0	

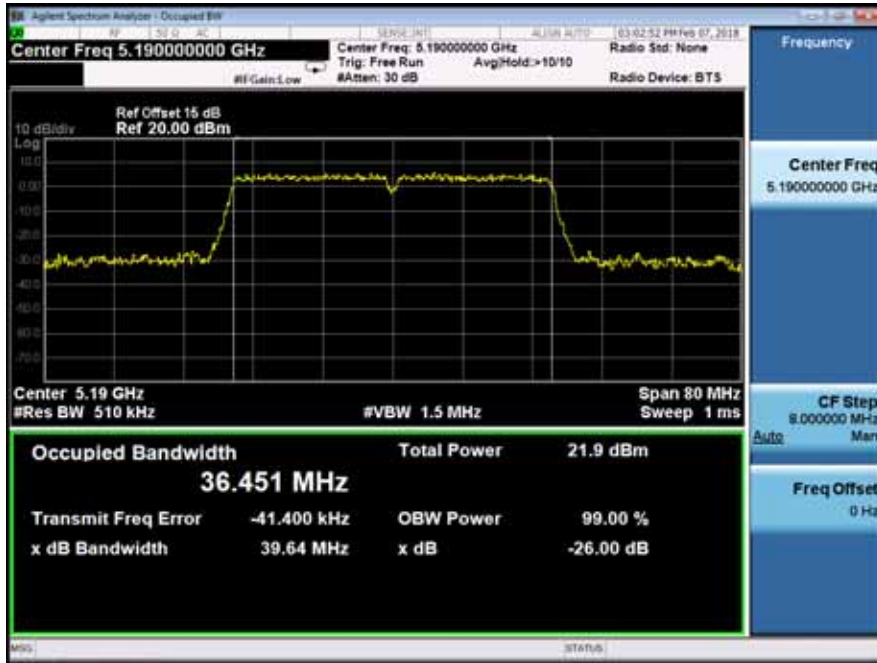

Ant1

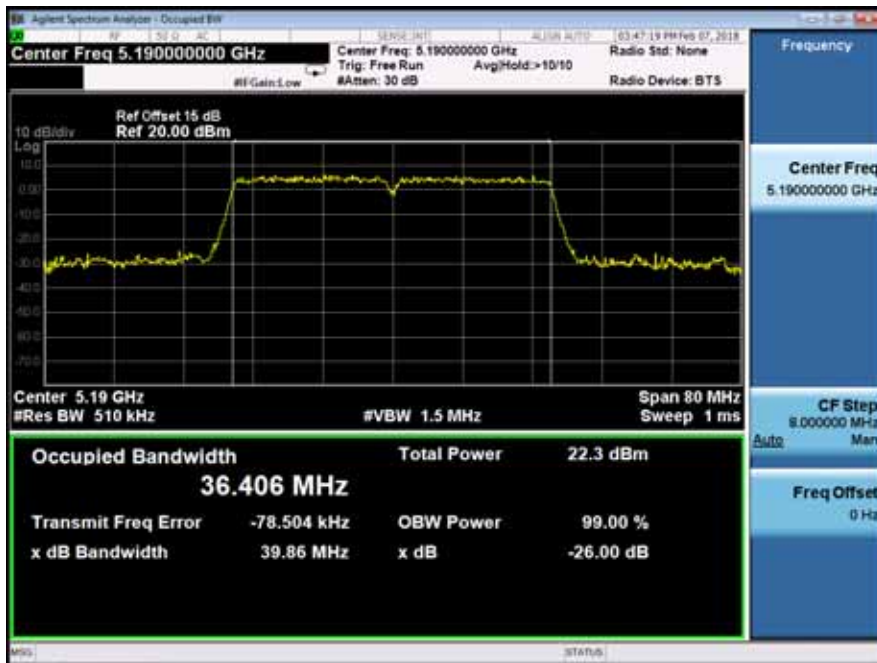

Emission Bandwidth&99% Occupied Bandwidth	UNII Band I
Test Model 802.11ac(VHT40) mode	Frequency(MHz) 5230

Ant0



Ant1

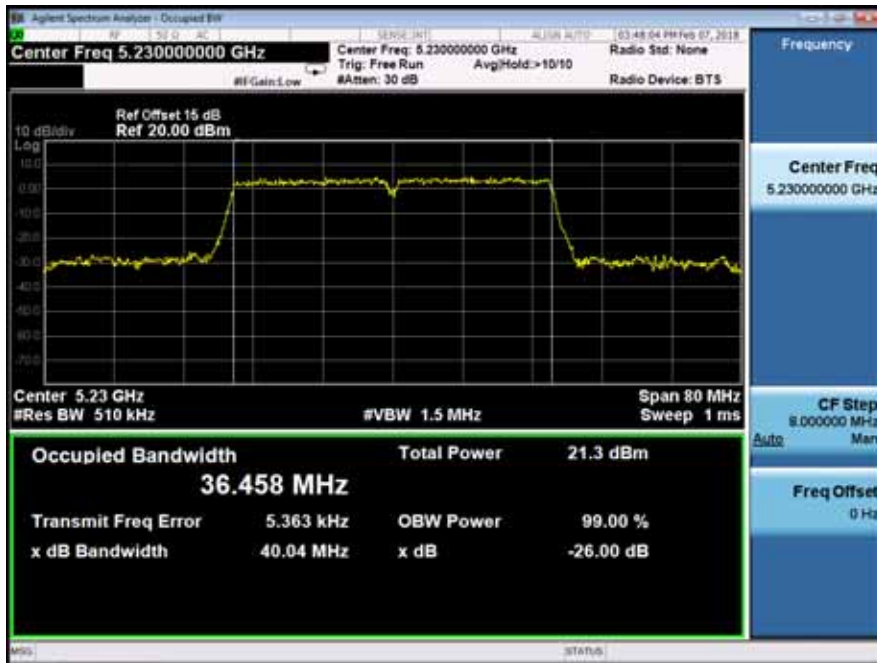

Emission Bandwidth&99% Occupied Bandwidth	UNII Band II-A
Test Model 802.11ac(VHT40) mode	Frequency(MHz) 5270
Ant0	

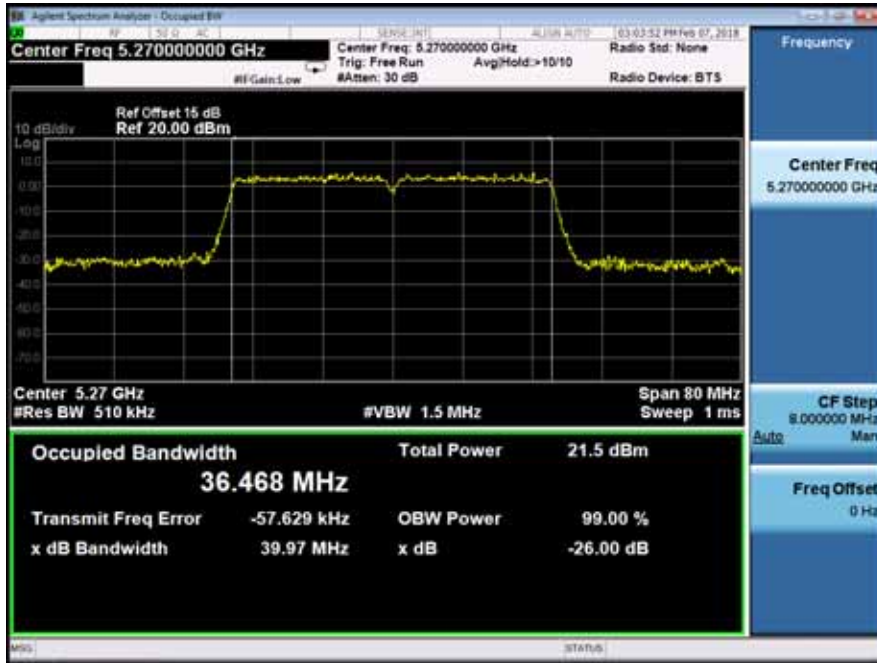

Ant1

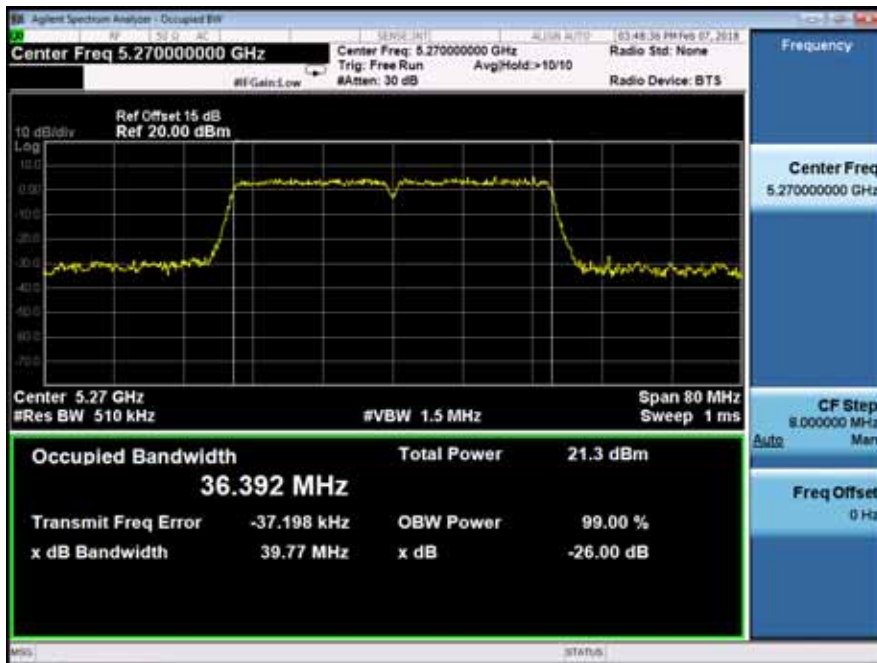

Emission Bandwidth&99% Occupied Bandwidth	UNII Band II-A
Test Model 802.11ac(VHT40) mode	Frequency(MHz) 5310
Ant0	



Ant1

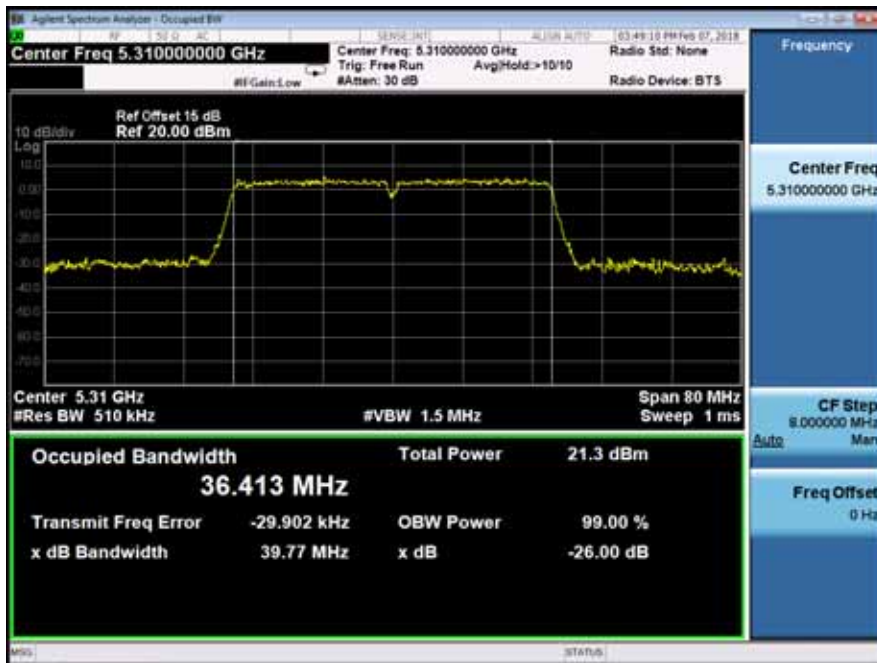

Emission Bandwidth&99% Occupied Bandwidth	UNII Band II-C
Test Model 802.11ac(VHT40) mode	Frequency(MHz) 5510

Ant0

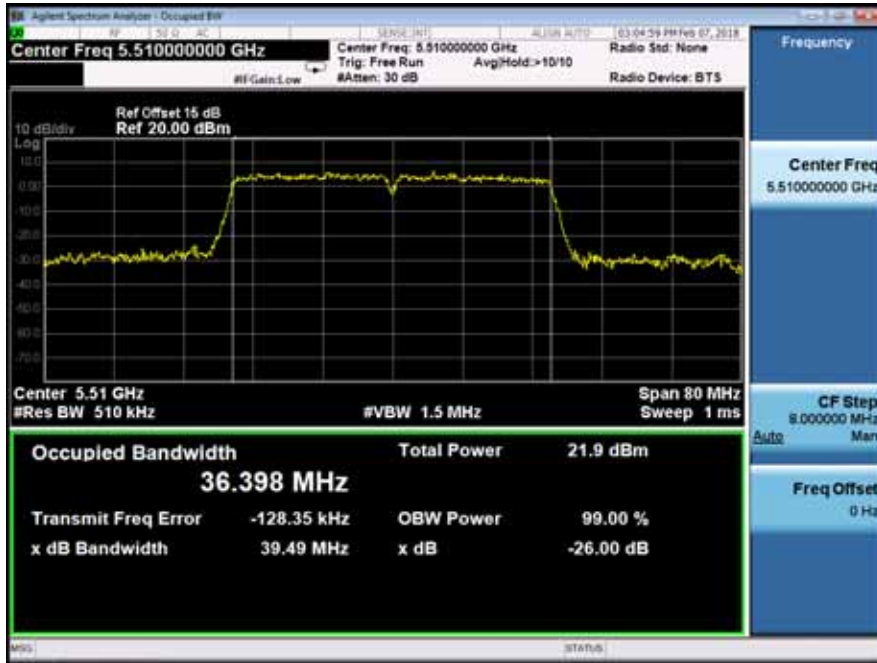

Ant1

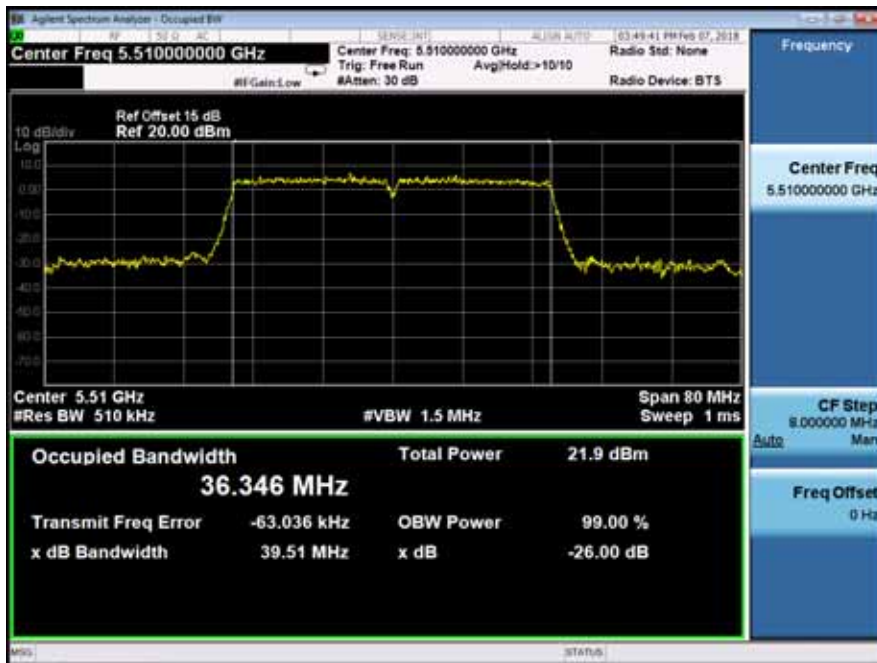

Emission Bandwidth&99% Occupied Bandwidth	UNII Band II-C
Test Model 802.11ac(VHT40) mode	Frequency(MHz) 5590
Ant0	

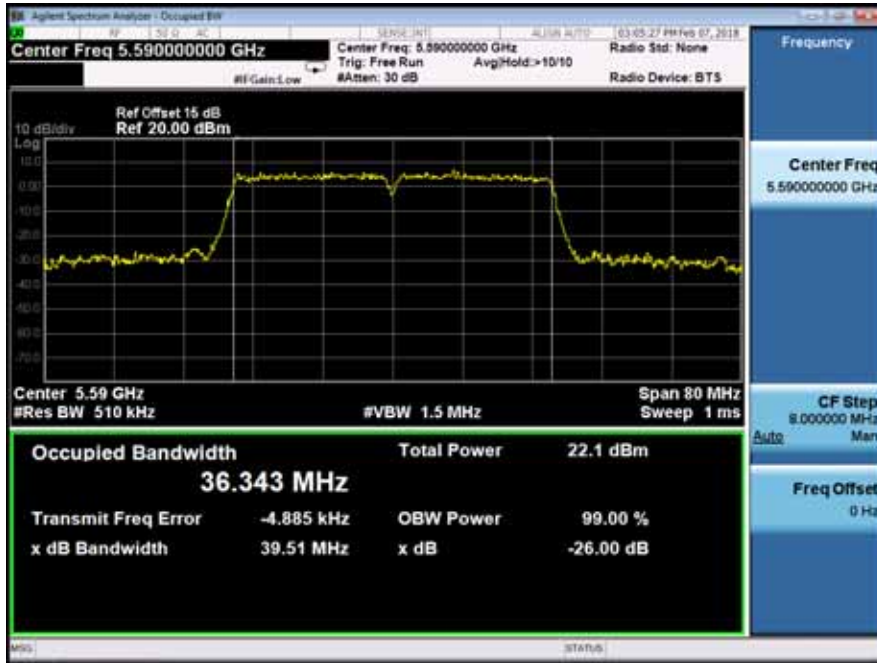

Ant1

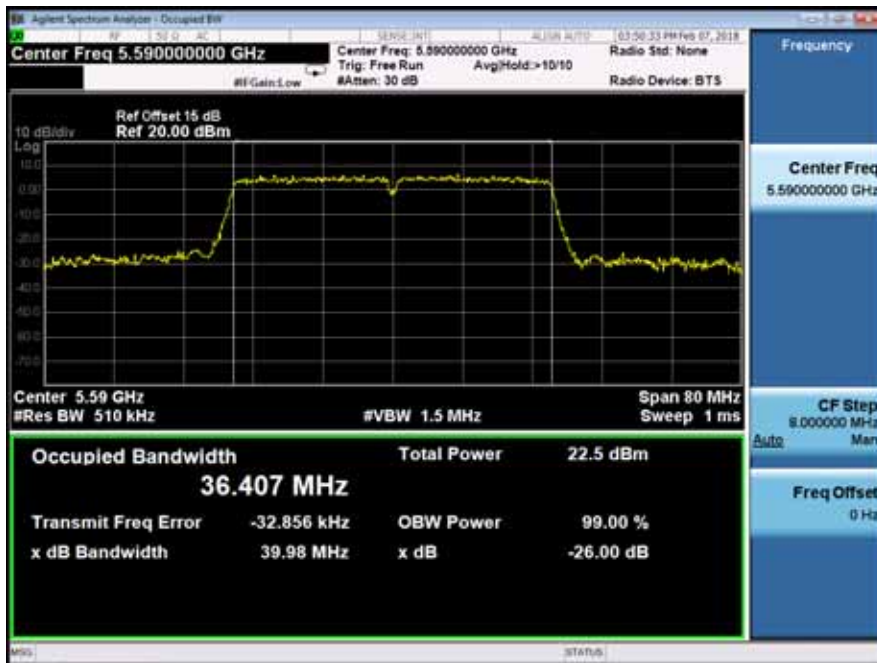

Emission Bandwidth&99% Occupied Bandwidth	UNII Band II-C
Test Model 802.11ac(VHT40) mode	Frequency(MHz) 5670
Ant0	



Ant1

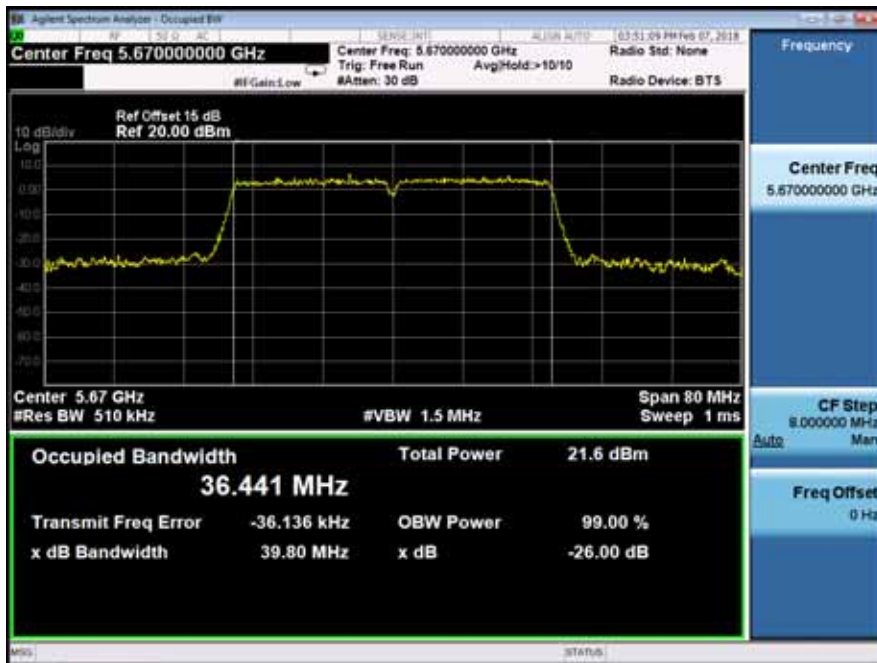

Emission Bandwidth&99% Occupied Bandwidth	UNII Band III
Test Model 802.11ac(VHT40) mode	Frequency(MHz) 5755
Ant0	



Ant1

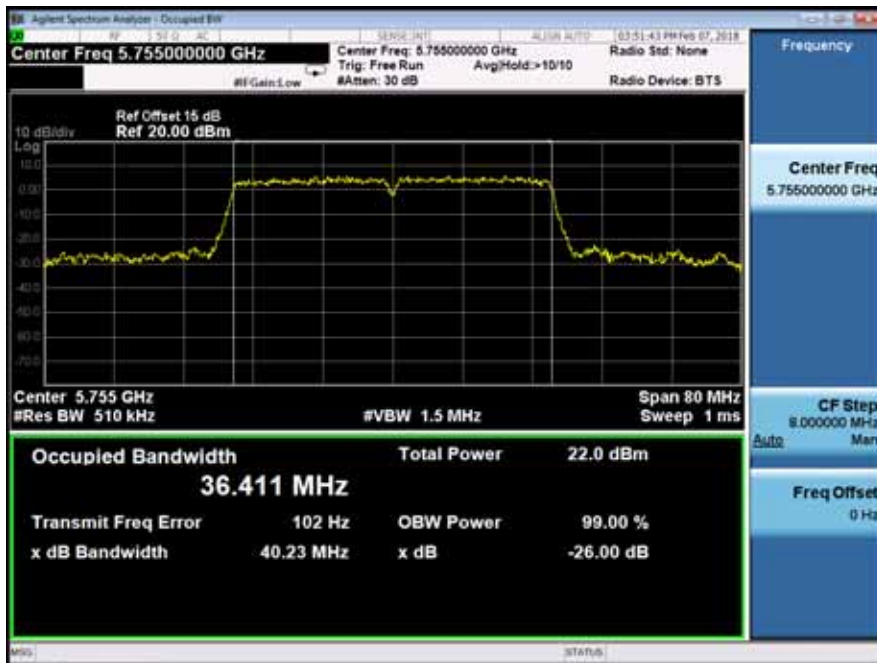

Emission Bandwidth&99% Occupied Bandwidth	UNII Band III
Test Model 802.11ac(VHT40) mode	Frequency(MHz) 5795
Ant0	

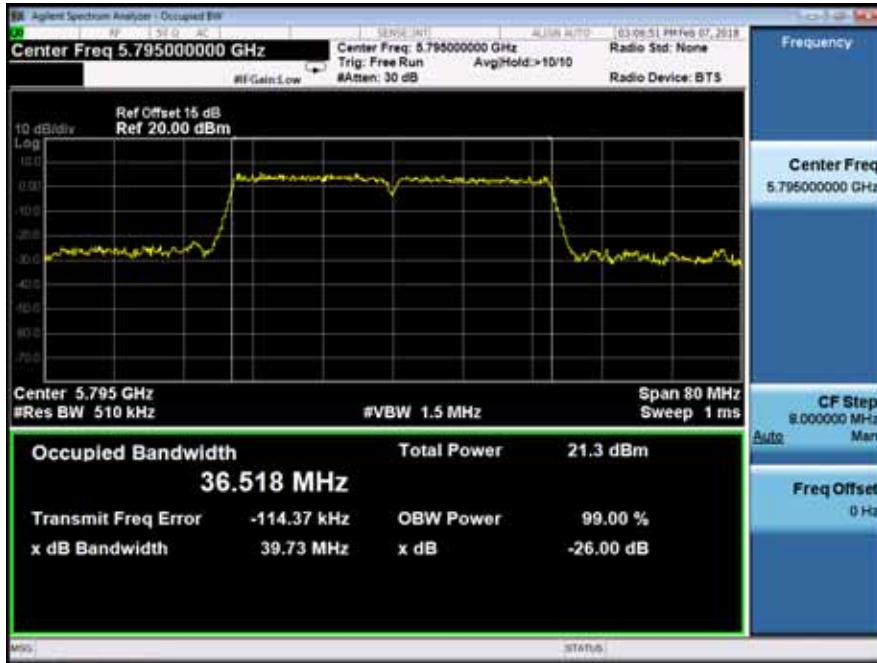

Ant1



Emission Bandwidth&99% Occupied Bandwidth	UNII Band I
Test Model 802.11ac(VHT80) mode	Frequency(MHz) 5210
Ant0	



Ant1

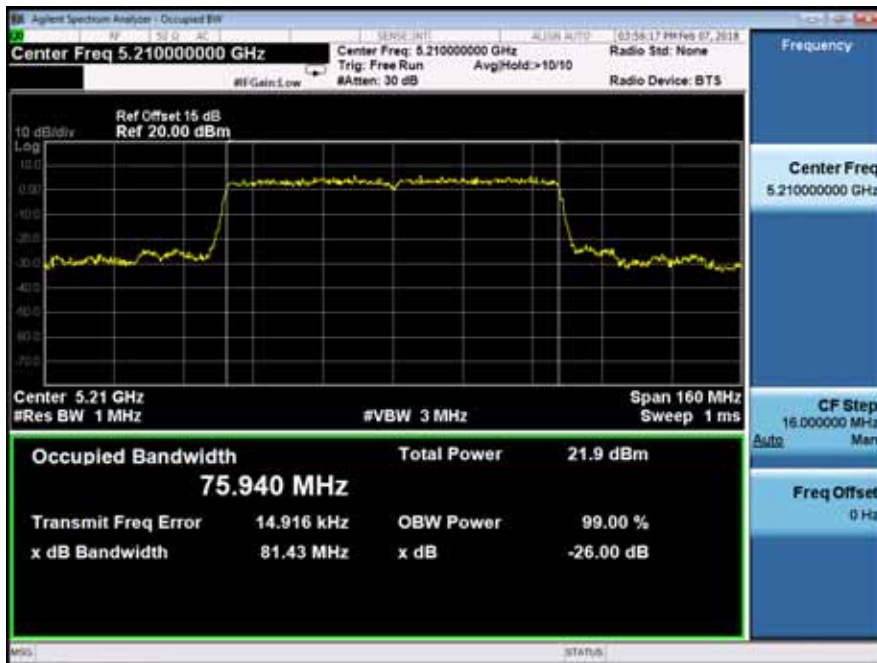

Emission Bandwidth&99% Occupied Bandwidth	UNII Band II-A
Test Model 802.11ac(VHT80) mode	Frequency(MHz) 5290
Ant0	

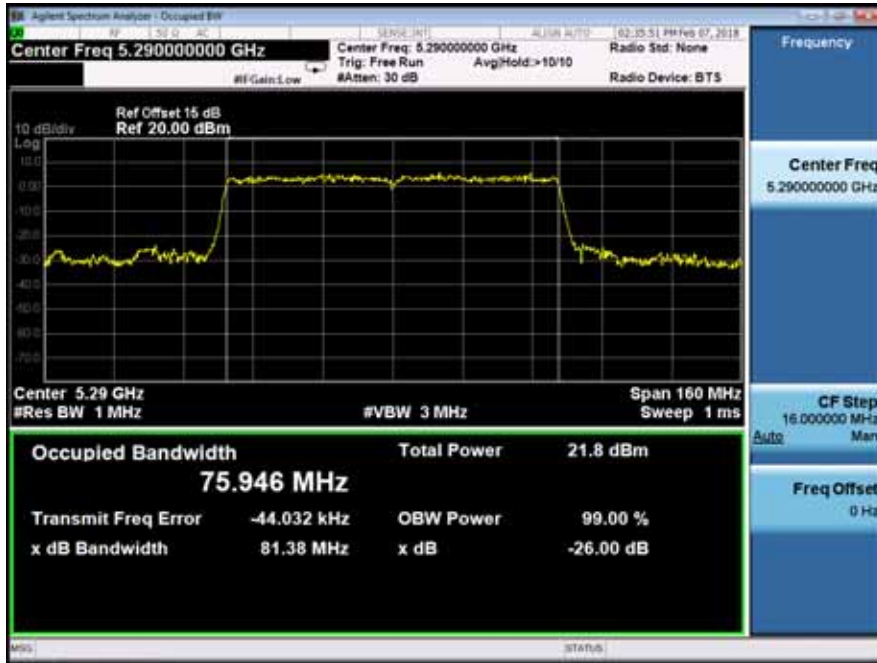

Ant1

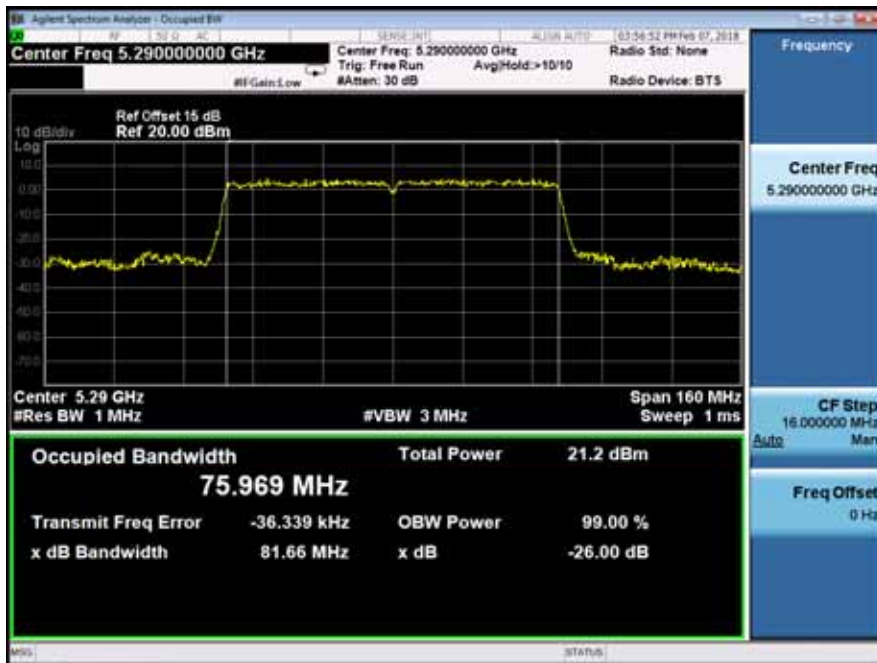

Emission Bandwidth&99% Occupied Bandwidth	UNII Band II-C
Test Model 802.11ac(VHT80) mode	Frequency(MHz) 5530
Ant0	



Ant1

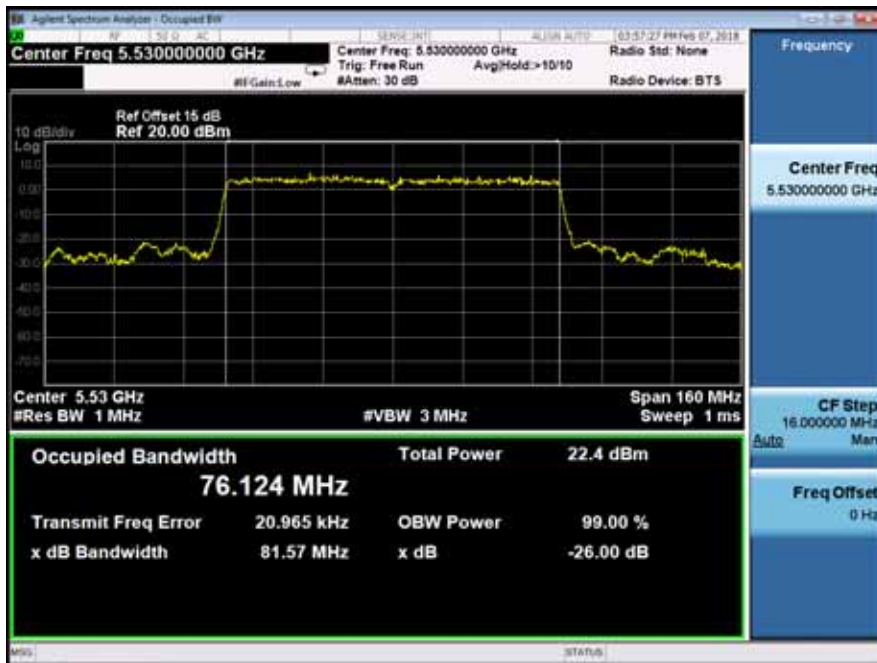

Emission Bandwidth&99% Occupied Bandwidth	UNII Band II-C
Test Model 802.11ac(VHT80) mode	Frequency(MHz) 5610

Ant0



Ant1

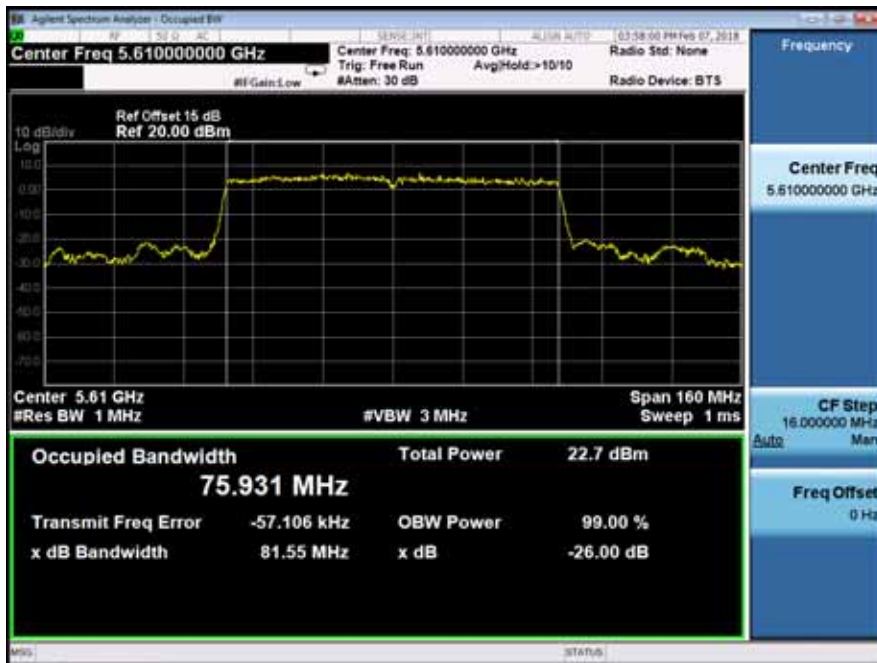

Emission Bandwidth&99% Occupied Bandwidth	UNII Band III
Test Model 802.11ac(VHT80) mode	Frequency(MHz) 5775

Ant0



Ant1



Minimum Emission Bandwidth	UNII Band III	
Test Model	802.11a mode	Frequency(MHz)
Ant0		5745



Ant1



Minimum Emission Bandwidth	UNII Band III	
Test Model	802.11a mode	5785
Ant0		



Ant1



Minimum Emission Bandwidth	UNII Band III	
Test Model	802.11a mode	Frequency(MHz)
Ant0		5825



Ant1



Minimum Emission Bandwidth	UNII Band III	
Test Model	802.11n(VHT20) mode	Frequency(MHz)
Ant0		5745



Ant1



Minimum Emission Bandwidth	UNII Band III	
Test Model	802.11n(VHT20) mode	Frequency(MHz)
Ant0		5785

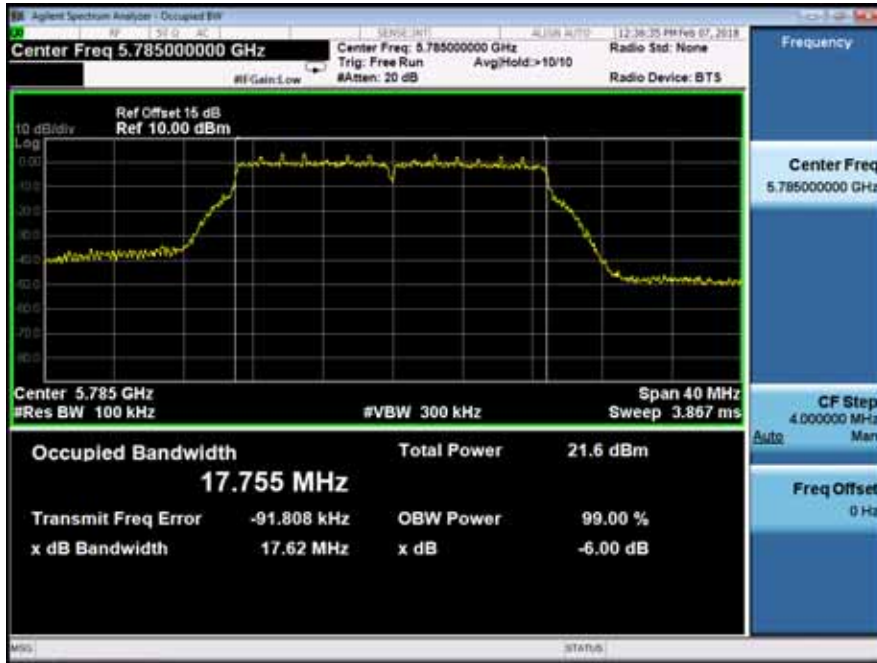

Ant1



Minimum Emission Bandwidth	UNII Band III	
Test Model	802.11n(VHT20) mode	Frequency(MHz)
Ant0		5825

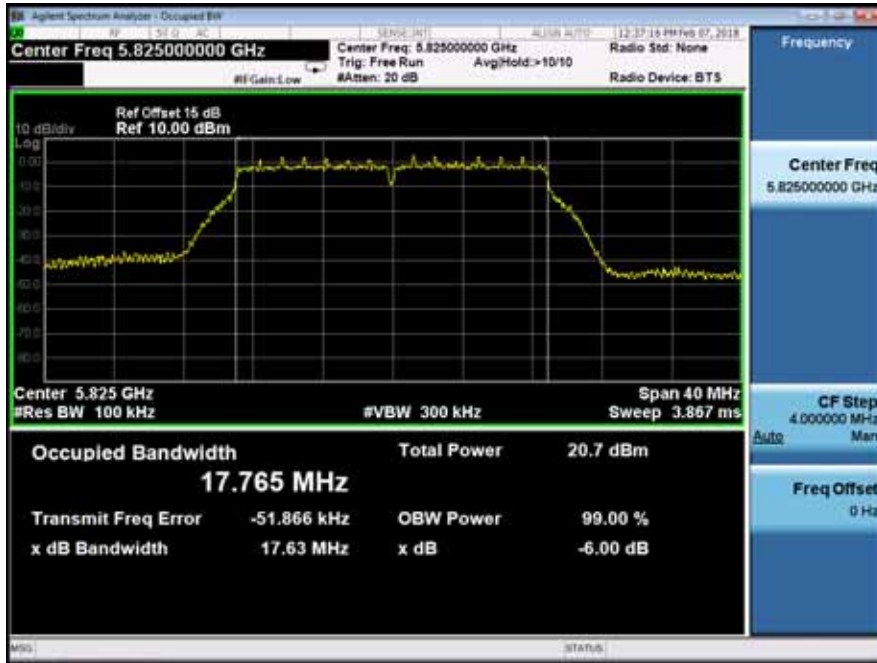

Ant1

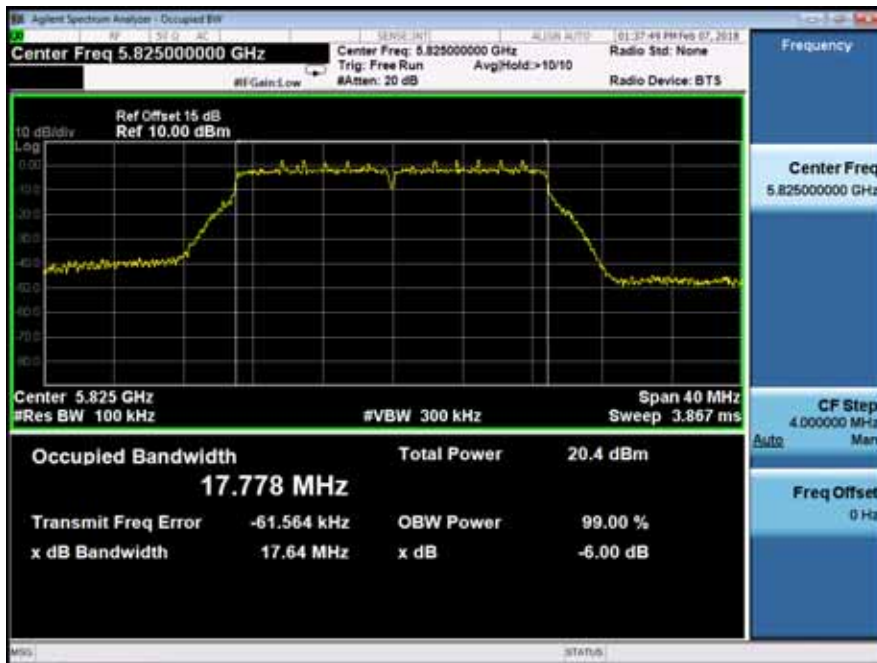

Minimum Emission Bandwidth	UNII Band III	
Test Model	802.11ac(VHT20) mode	Frequency(MHz)
Ant0		5745

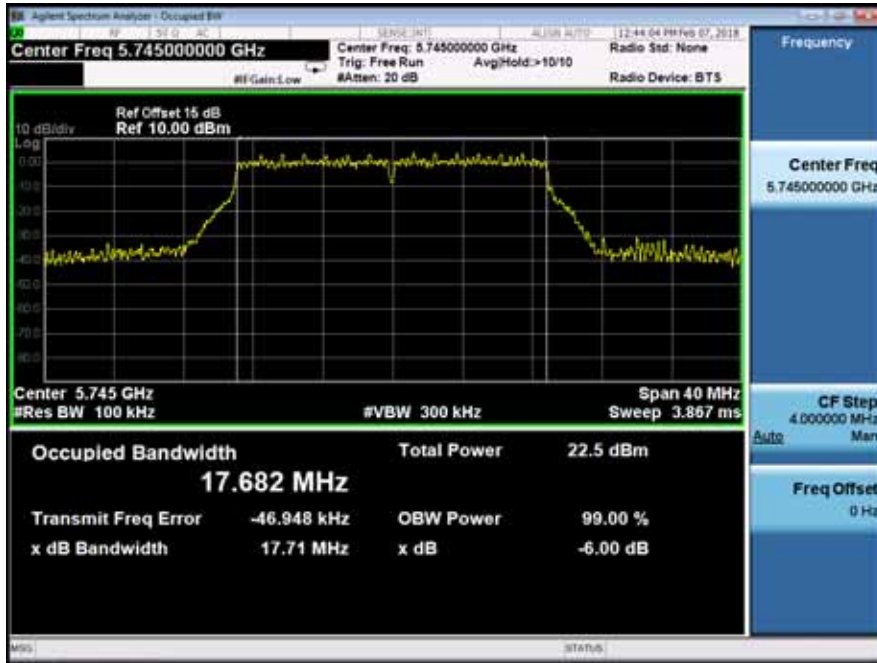

Ant1

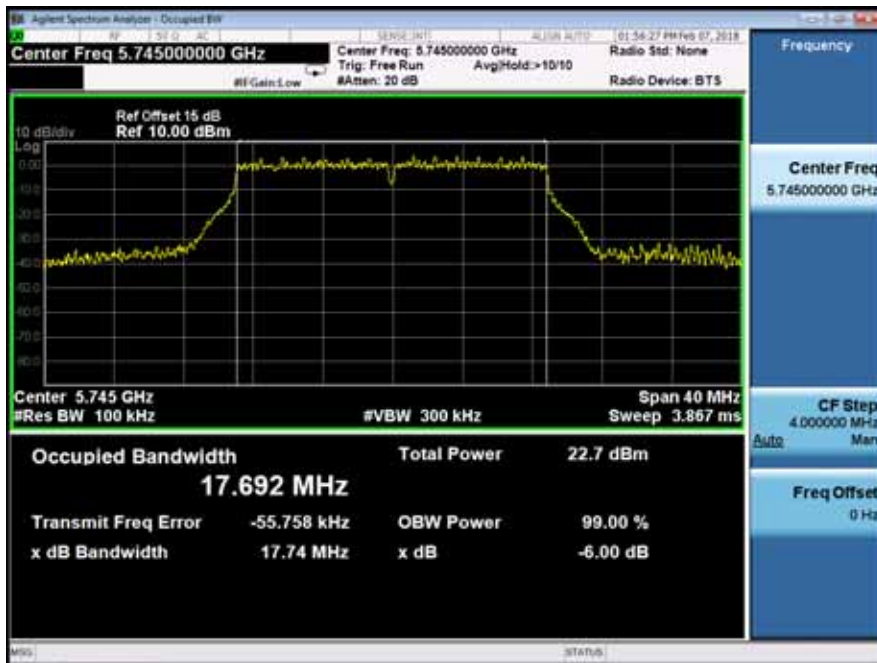

Minimum Emission Bandwidth	UNII Band III	
Test Model	802.11ac(VHT20) mode	Frequency(MHz)
Ant0		5785

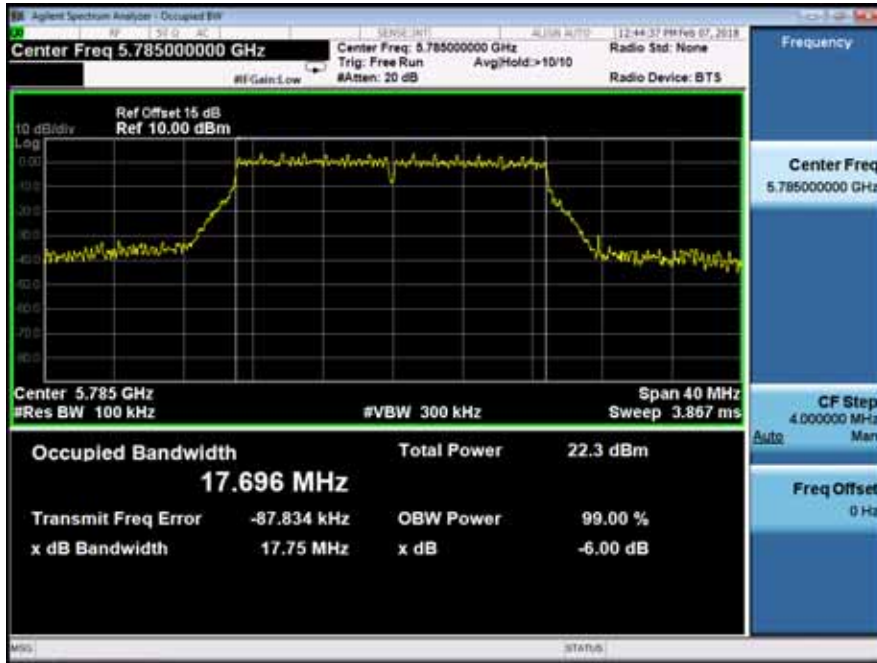

Ant1

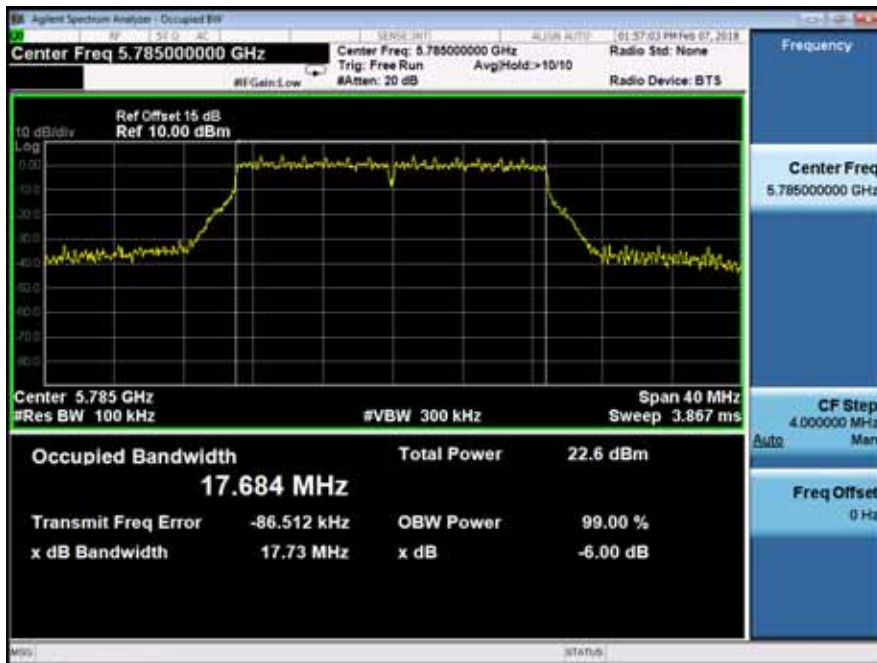

Minimum Emission Bandwidth	UNII Band III	
Test Model	802.11ac(VHT20) mode	Frequency(MHz)
Ant0		5825

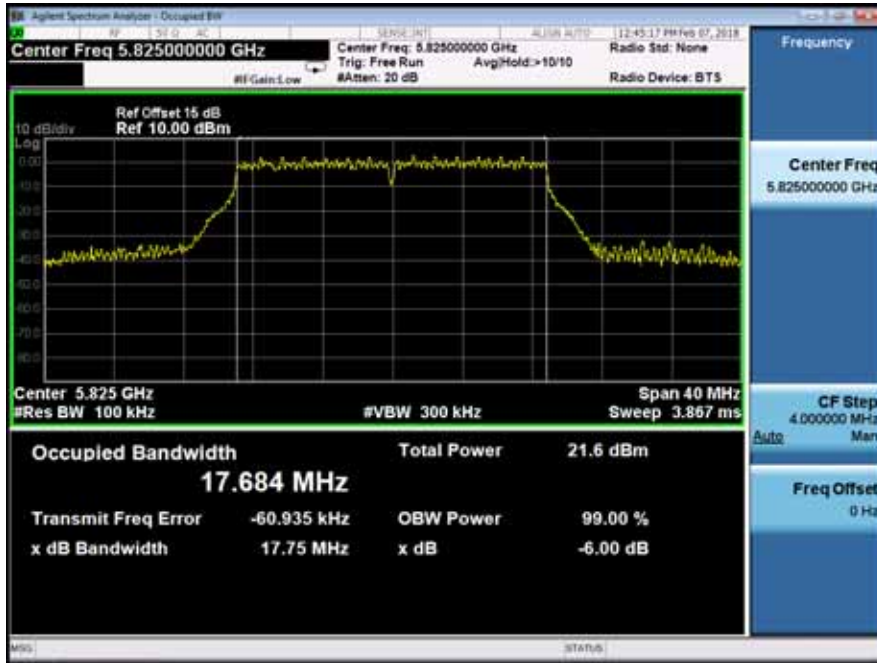

Ant1

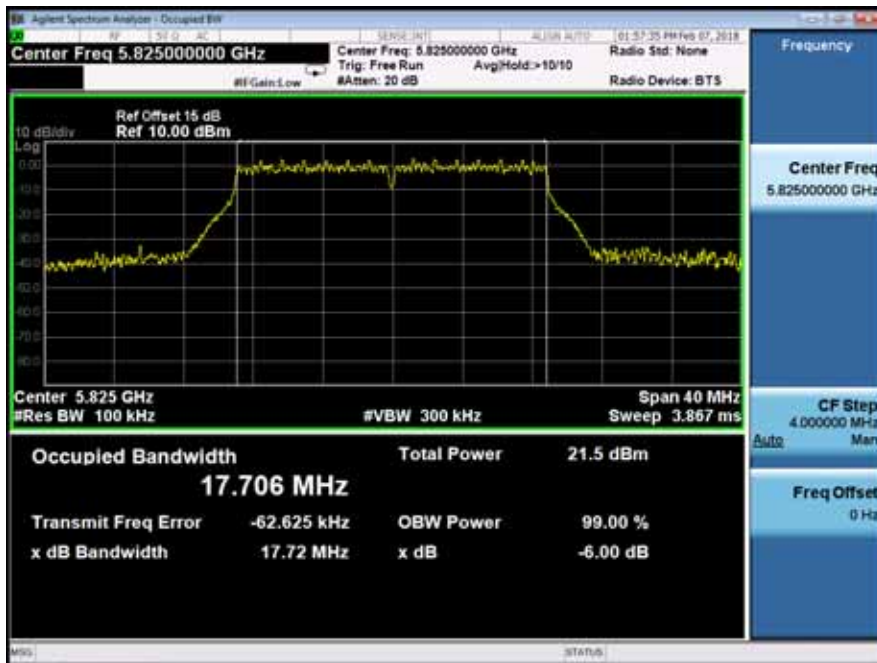

Minimum Emission Bandwidth	UNII Band III	
Test Model	802.11n(VHT40) mode	Frequency(MHz)
Ant0		5755



Ant1

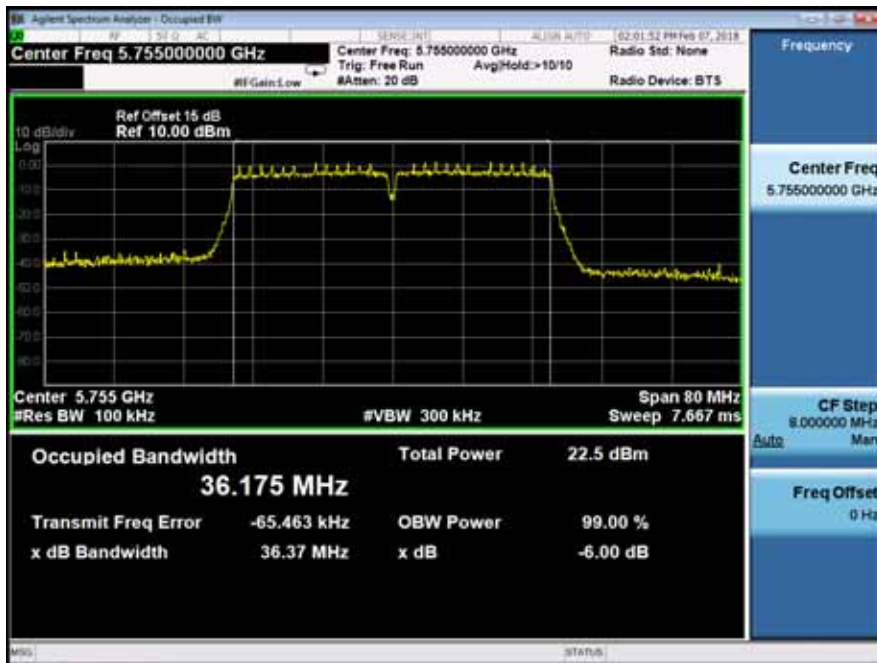

Minimum Emission Bandwidth	UNII Band III	
Test Model	802.11n(VHT40) mode	Frequency(MHz)
Ant0		5795

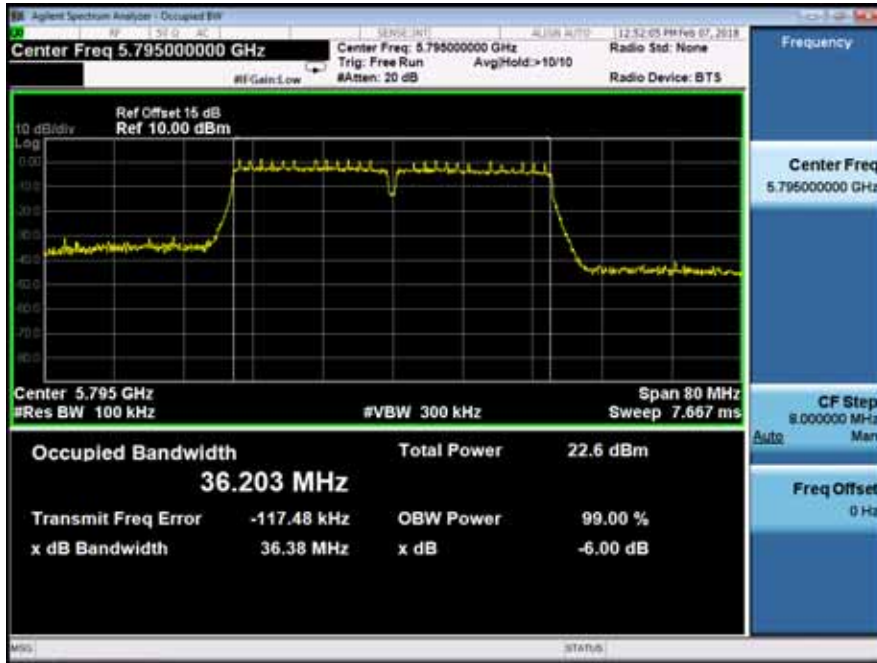

Ant1

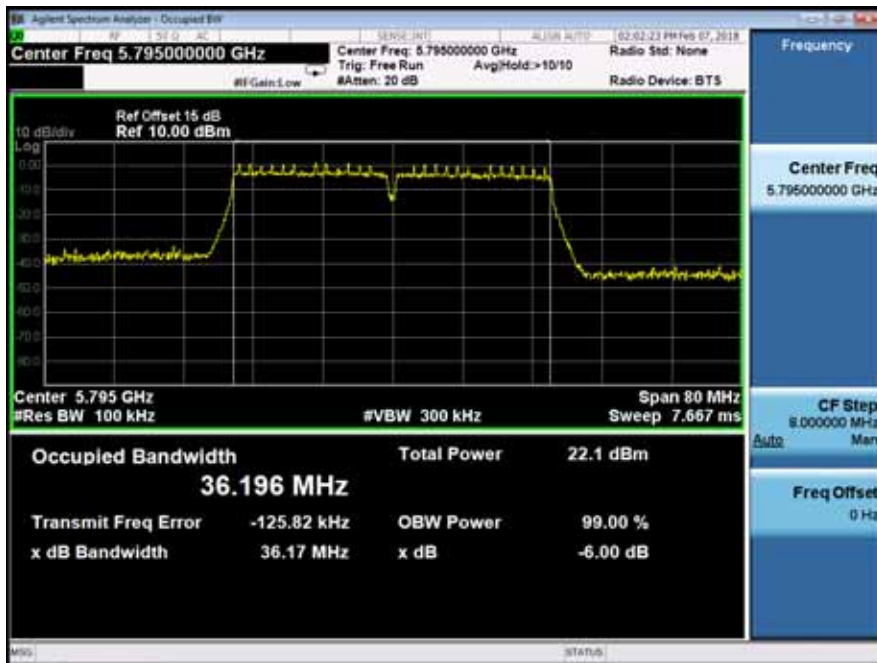

Minimum Emission Bandwidth	UNII Band III	
Test Model	802.11ac(VHT40) mode	Frequency(MHz)
Ant0		5755

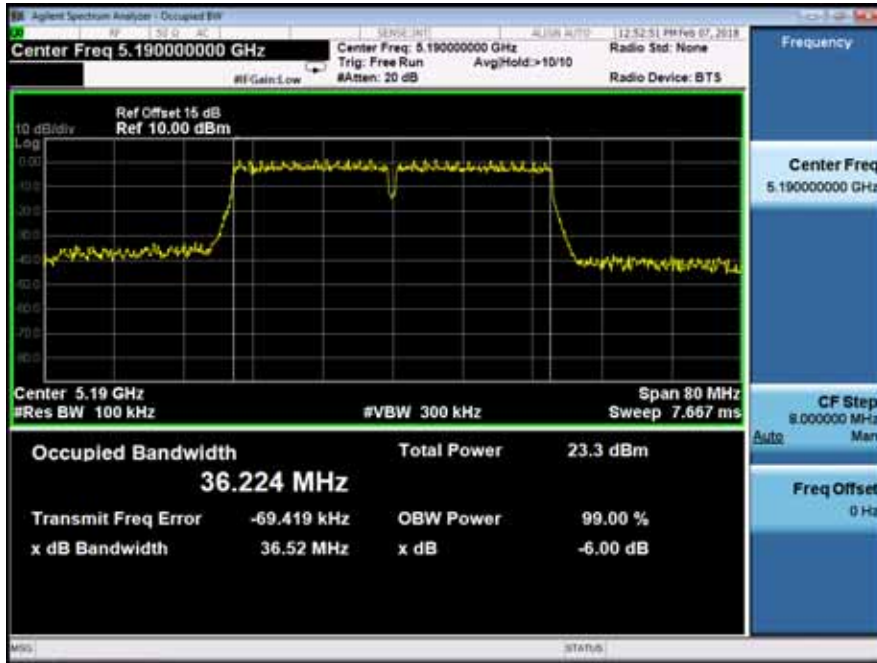

Ant1

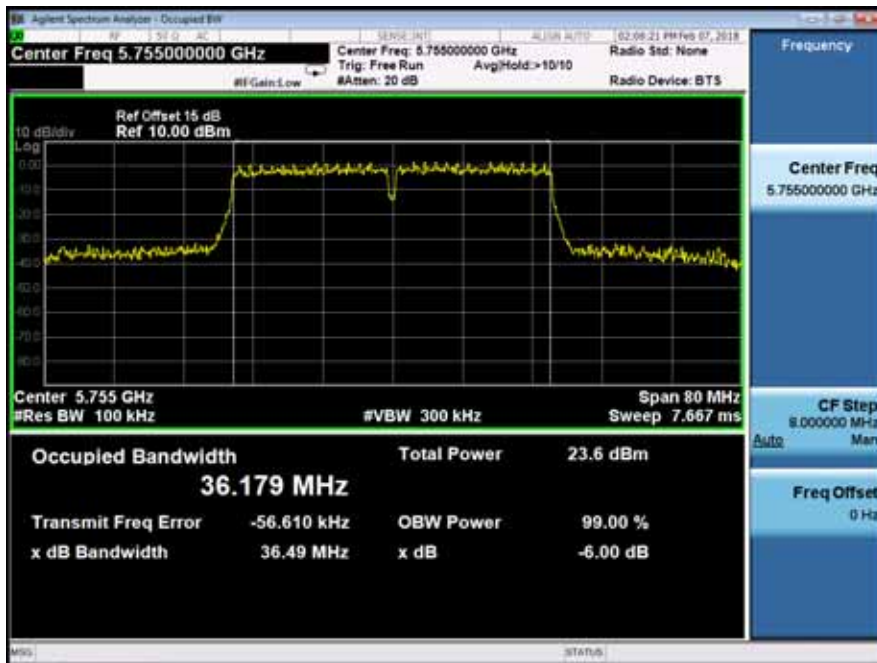

Minimum Emission Bandwidth	UNII Band III	
Test Model	802.11ac(VHT40) mode	Frequency(MHz)
Ant0		5795

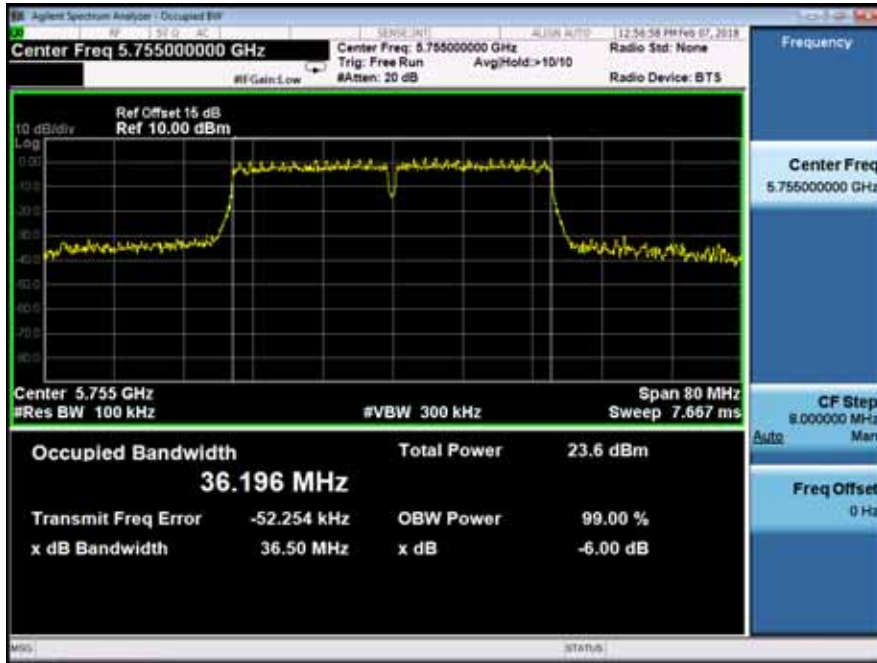

Ant1

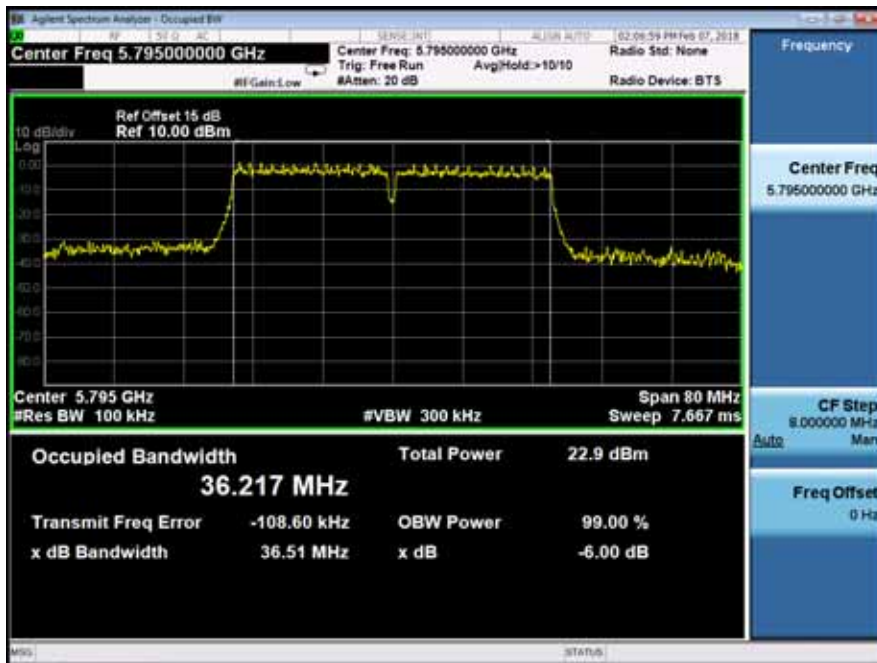

Minimum Emission Bandwidth	UNII Band III	
Test Model	802.11ac(VHT80) mode	Frequency(MHz)
Ant0		5775



Ant1

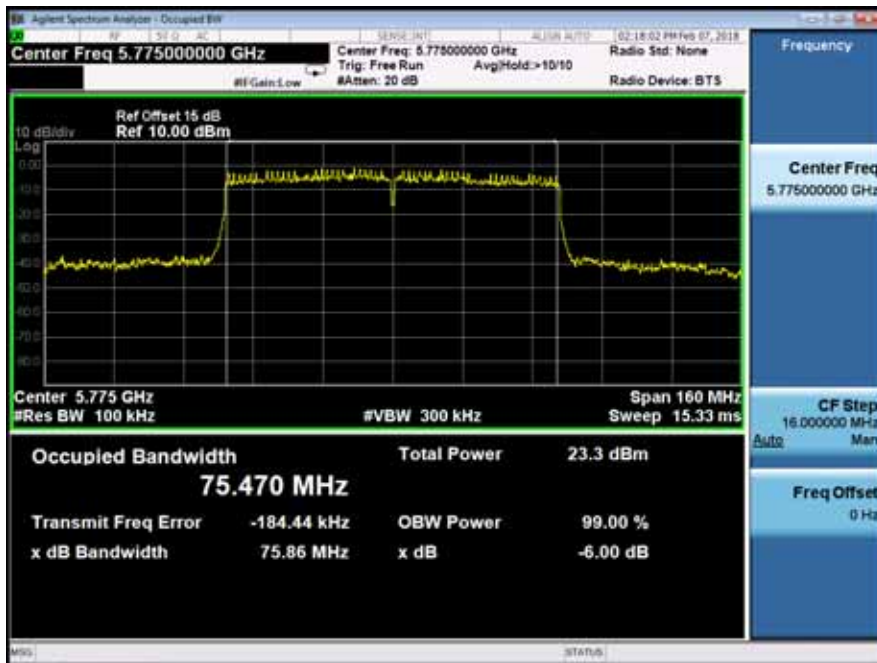

8.2 MAXIMUM CONDUCTED OUTPUT POWER

8.2.1 Applicable Standard

According to FCC Part 15.407(a)(1) for UNII Band I

According to FCC Part 15.407(a)(2) for UNII Band II-A and UNII Band II-C

According to FCC Part 15.407(a)(3) for UNII Band III

According to 789033 D02 Section II(E)

8.2.2 Conformance Limit

■ For the band 5.15-5.25 GHz,

(a) (1) (i) For an outdoor access point operating in the band 5.15-5.25 GHz, the maximum conducted output power over the frequency band of operation shall not exceed 1 W provided the maximum antenna gain does not exceed 6 dBi. If transmitting antennas of directional gain greater than 6 dBi are used, both the maximum conducted output power and the maximum power spectral density shall be reduced by the amount in dB that the directional gain of the antenna exceeds 6 dBi. The maximum e.i.r.p. at any elevation angle above 30 degrees as measured from the horizon must not exceed 125 mW (21 dBm).

(a) (1) (ii) For an indoor access point operating in the band 5.15-5.25 GHz, the maximum conducted output power over the frequency band of operation shall not exceed 1 W provided the maximum antenna gain does not exceed 6 dBi. If transmitting antennas of directional gain greater than 6 dBi are used, both the maximum conducted output power and the maximum power spectral density shall be reduced by the amount in dB that the directional gain of the antenna exceeds 6 dBi.

(a) (1) (iii) For fixed point-to-point access points operating in the band 5.15-5.25 GHz, the maximum conducted output power over the frequency band of operation shall not exceed 1 W. Fixed point-to-point U-NII devices may employ antennas with directional gain up to 23 dBi without any corresponding reduction in the maximum conducted output power or maximum power spectral density. For fixed point-to-point transmitters that employ a directional antenna gain greater than 23 dBi, a 1 dB reduction in maximum conducted output power and maximum power spectral density is required for each 1 dB of antenna gain in excess of 23 dBi. Fixed, point-to-point operations exclude the use of point-to-multipoint systems, omnidirectional applications, and multiple collocated transmitters transmitting the same information. The operator of the U-NII device, or if the equipment is professionally installed, the installer, is responsible for ensuring that systems employing high gain directional antennas are used exclusively for fixed, point-to-point operations.

(a) (1) (iv) For mobile and portable client devices in the 5.15-5.25 GHz band, the maximum conducted output power over the frequency band of operation shall not exceed 250 mW provided the maximum antenna gain does not exceed 6 dBi. If transmitting antennas of directional gain greater than 6 dBi are used, both the maximum conducted output power and the maximum power spectral density shall be reduced by the amount in dB that the directional gain of the antenna exceeds 6 dBi.

■ For the 5.25-5.35 GHz and 5.47-5.725 GHz bands

(a) (2) the maximum conducted output power over the frequency bands of operation shall not exceed the lesser of 250 mW or $11 \text{ dBm} + 10 \log B$, where B is the 26 dB emission bandwidth in megahertz. In addition, the maximum power spectral density shall not exceed 11 dBm in any 1 megahertz band. If transmitting antennas of directional gain greater than 6 dBi are used, both the maximum conducted output power and the maximum power spectral density shall be reduced by the amount in dB that the directional gain of the antenna exceeds 6 dBi.

■ For the band 5.725-5.85 GHz

(a) (3) For the band 5.725-5.85 GHz, the maximum conducted output power over the frequency band of operation shall not exceed 1 W. In addition, the maximum power spectral density shall not exceed 30 dBm in any 500-kHz band. If transmitting antennas of directional gain greater than 6 dBi are used, both the maximum conducted output power and the maximum power spectral density shall be reduced by the amount in dB that the directional gain of the antenna exceeds 6 dBi.

8.2.3 Test Configuration

Test according to clause 6.1 radio frequency test setup

8.2.4 Test Procedure

The maximum average conducted output power can be measured using Method PM-G (Measurement using a gated RF average power meter):

Measurements may be performed using a wideband gated RF power meter provided that the gate parameters are adjusted such that the power is measured only when the EUT is transmitting at its maximum power control level. Since the measurement is made only during the ON time of the transmitter, no duty cycle correction factor is required.

- a. The Transmitter output (antenna port) was connected to the power meter.
- b. Turn on the EUT and power meter and then record the power value.
- c. Repeat above procedures on all channels needed to be tested.

8.2.5 Test Results

<input checked="" type="checkbox"/> 802.11a mode						
Temperature :		28	Test Date :		February 07, 2018	
Humidity :		65 %	Test By:		King Kong	
Band	Channel Number	Channel Freq. (MHz)	Conducted Output Power(dBm)		Limit (dBm)	Verdict
			Ant0	Ant1		
UNII Band I	CH36	5180	16.90	16.75	22.49	Pass
	CH40	5200	16.88	16.54	22.49	Pass
	CH48	5240	16.12	16.54	22.49	Pass
UNII Band II-A	CH52	5260	16.05	16.63	22.49	Pass
	CH56	5280	16.44	16.76	22.49	Pass
	CH64	5320	15.89	16.45	22.49	Pass
UNII Band II-C	CH100	5500	16.55	15.88	22.49	Pass
	CH120	5600	16.61	15.83	22.49	Pass
	CH140	5700	16.25	15.63	22.49	Pass
UNII Band III	CH149	5745	16.57	15.75	28.49	Pass
	CH157	5785	16.84	15.84	28.49	Pass
	CH165	5825	16.18	15.96	28.49	Pass
Note: N/A (Not Applicable)						

<input checked="" type="checkbox"/> 802.11n(HT20) mode							
Temperature :		28	Test Date :		February 07, 2018		
Humidity :		65 %	Test By:		King Kong		
Band	Channel Number	Channel Freq. (MHz)	Conducted Output Power(dBm)			Limit (dBm)	Verdict
			Ant0	Ant1	Ant0+Ant1		
UNII Band I	CH36	5180	15.81	15.89	18.86	22.49	Pass
	CH40	5200	15.81	15.67	18.75	22.49	Pass
	CH48	5240	15.06	15.67	18.39	22.49	Pass
UNII Band II-A	CH52	5260	15.02	15.77	18.42	22.49	Pass
	CH56	5280	15.40	15.50	18.46	22.49	Pass
	CH64	5320	15.11	15.57	18.36	22.49	Pass
UNII Band II-C	CH100	5500	15.51	15.76	18.65	22.49	Pass
	CH120	5600	15.49	15.66	18.59	22.49	Pass
	CH140	5700	15.12	15.43	18.29	22.49	Pass
UNII Band III	CH149	5745	15.48	15.59	18.55	28.49	Pass
	CH157	5785	15.66	15.87	18.78	28.49	Pass
	CH165	5825	14.87	15.94	18.45	28.49	Pass

802.11ac(VHT20) mode

Temperature : 28 Test Date : February 07, 2018
 Humidity : 65 % Test By: King Kong

Band	Channel Number	Channel Freq. (MHz)	Conducted Output Power(dBm)			Limit (dBm)	Verdict
			Ant0	Ant1	Ant0+Ant1		
UNII Band I	CH36	5180	16.22	16.99	19.63	22.49	Pass
	CH40	5200	16.06	16.88	19.50	22.49	Pass
	CH48	5240	15.49	16.89	19.26	22.49	Pass
UNII Band II-A	CH52	5260	15.33	16.88	19.18	22.49	Pass
	CH56	5280	15.63	16.76	19.24	22.49	Pass
	CH64	5320	15.29	16.58	18.99	22.49	Pass
UNII Band II-C	CH100	5500	15.88	15.19	18.56	22.49	Pass
	CH120	5600	15.98	15.97	18.99	22.49	Pass
	CH140	5700	15.60	15.79	18.71	22.49	Pass
UNII Band III	CH149	5745	15.79	15.97	18.89	28.49	Pass
	CH157	5785	16.18	16.11	19.16	28.49	Pass
	CH165	5825	15.41	16.10	18.78	28.49	Pass

802.11n(HT40) mode

Temperature : 28 Test Date : February 07, 2018
 Humidity : 65 % Test By: King Kong

Band	Channel Number	Channel Freq. (MHz)	Conducted Output Power(dBm)			Limit (dBm)	Verdict
			Ant0	Ant1	Ant0+Ant1		
UNII Band I	CH38	5190	15.19	14.96	18.09	22.49	Pass
	CH46	5230	14.32	14.66	17.50	22.49	Pass
UNII Band II-A	CH54	5270	14.53	14.96	17.76	22.49	Pass
	CH62	5310	14.51	14.81	17.67	22.49	Pass
UNII Band II-C	CH102	5510	15.34	14.38	17.90	22.49	Pass
	CH118	5590	15.17	14.09	17.67	22.49	Pass
	CH134	5670	14.17	14.39	17.29	22.49	Pass
UNII Band III	CH151	5755	14.81	15.25	18.05	28.49	Pass
	CH159	5795	15.08	15.44	18.27	28.49	Pass

802.11ac(VHT40) mode

Temperature : 28 Test Date : February 07, 2018
 Humidity : 65 % Test By: King Kong

Band	Channel Number	Channel Freq. (MHz)	Conducted Output Power(dBm)			Limit (MHz)	Verdict
			Ant0	Ant1	Ant0+Ant1		
UNII Band I	CH38	5190	15.39	15.11	18.26	22.49	Pass
	CH46	5230	14.57	14.81	17.70	22.49	Pass
UNII Band II-A	CH54	5270	14.74	15.23	18.00	22.49	Pass
	CH62	5310	14.64	15.09	17.88	22.49	Pass
UNII Band II-C	CH102	5510	15.25	14.45	17.88	22.49	Pass
	CH118	5590	15.13	14.14	17.67	22.49	Pass
	CH134	5670	14.38	14.58	17.49	22.49	Pass
UNII Band III	CH151	5755	14.81	15.22	18.03	28.49	Pass
	CH159	5795	15.07	15.42	18.26	28.49	Pass

8.3 MAXIMUM PEAK POWER DENSITY

8.3.1 Applicable Standard

According to FCC Part 15.407(a)(1) for UNII Band I

According to FCC Part 15.407(a)(2) for UNII Band II-A and UNII Band II-C

According to FCC Part 15.407(a)(3) for UNII Band III

According to 789033 D02 Section II(F)

8.3.2 Conformance Limit

■ For the band 5.15-5.25 GHz,

(a) (1) (i) For an outdoor access point operating in the band 5.15-5.25 GHz, the maximum conducted output power over the frequency band of operation shall not exceed 1 W provided the maximum antenna gain does not exceed 6 dBi. If transmitting antennas of directional gain greater than 6 dBi are used, both the maximum conducted output power and the maximum power spectral density shall be reduced by the amount in dB that the directional gain of the antenna exceeds 6 dBi. The maximum e.i.r.p. at any elevation angle above 30 degrees as measured from the horizon must not exceed 125 mW (21 dBm).

(a) (1) (ii) For an indoor access point operating in the band 5.15-5.25 GHz, the maximum conducted output power over the frequency band of operation shall not exceed 1 W provided the maximum antenna gain does not exceed 6 dBi. If transmitting antennas of directional gain greater than 6 dBi are used, both the maximum conducted output power and the maximum power spectral density shall be reduced by the amount in dB that the directional gain of the antenna exceeds 6 dBi.

(a) (1) (iii) For fixed point-to-point access points operating in the band 5.15-5.25 GHz, the maximum conducted output power over the frequency band of operation shall not exceed 1 W. Fixed point-to-point U-NII devices may employ antennas with directional gain up to 23 dBi without any corresponding reduction in the maximum conducted output power or maximum power spectral density. For fixed point-to-point transmitters that employ a directional antenna gain greater than 23 dBi, a 1 dB reduction in maximum conducted output power and maximum power spectral density is required for each 1 dB of antenna gain in excess of 23 dBi. Fixed, point-to-point operations exclude the use of point-to-multipoint systems, omnidirectional applications, and multiple collocated transmitters transmitting the same information. The operator of the U-NII device, or if the equipment is professionally installed, the installer, is responsible for ensuring that systems employing high gain directional antennas are used exclusively for fixed, point-to-point operations.

(a) (1) (iv) For mobile and portable client devices in the 5.15-5.25 GHz band, the maximum conducted output power over the frequency band of operation shall not exceed 250 mW provided the maximum antenna gain does not exceed 6 dBi. If transmitting antennas of directional gain greater than 6 dBi are used, both the maximum conducted output power and the maximum power spectral density shall be reduced by the amount in dB that the directional gain of the antenna exceeds 6 dBi.

■ For the 5.25-5.35 GHz and 5.47-5.725 GHz bands

(b) (2) the maximum conducted output power over the frequency bands of operation shall not exceed the lesser of 250 mW or $11 \text{ dBm} + 10 \log B$, where B is the 26 dB emission bandwidth in megahertz. In addition, the maximum power spectral density shall not exceed 11 dBm in any 1 megahertz band. If transmitting antennas of directional gain greater than 6 dBi are used, both the maximum conducted output power and the maximum power spectral density shall be reduced by the amount in dB that the directional gain of the antenna exceeds 6 dBi.

■ For the band 5.725-5.85 GHz

(a) (3) For the band 5.725-5.85 GHz, the maximum conducted output power over the frequency band of operation shall not exceed 1 W. In addition, the maximum power spectral density shall not exceed 30 dBm in any 500-kHz band. If transmitting antennas of directional gain greater than 6 dBi are used, both the maximum conducted output power and the maximum power spectral density shall be reduced by the amount in dB that the directional gain of the antenna exceeds 6 dBi.

8.3.3 Test Configuration

Test according to clause 6.1 radio frequency test setup

8.3.4 Test Procedure

Methods refer to FCC KDB 789033

1) Create an average power spectrum for the EUT operating mode being tested by following the instructions in section E)2) for measuring maximum conducted output power using a spectrum analyzer or EMI receiver: select the appropriate test method (SA-3, or alternatives to each) and apply it up to, but not including, the step labeled, "Compute power...".

2) Use the peak search function on the instrument to find the peak of the spectrum.

3) The result is the PPSD.

4) The above procedures make use of 500kHz resolution bandwidth to satisfy the 500kHz measurement bandwidth specified in the 15.407(a)(5). That rule section also permits use of resolution bandwidths less than 1 MHz "provided that the measured power is integrated to show the total power over the measurement bandwidth" (i.e., 1 MHz). If measurements are performed using a reduced resolution bandwidth and integrated over 500kHz bandwidth

Note: As a practical matter, it is recommended to use reduced RBW of 500 kHz for the sections 5.c) and 5.d) above, since RBW=500 kHz is available on nearly all spectrum analyzers.

8.3.5 Test Results

<input checked="" type="checkbox"/> 802.11a mode						
Temperature :		28	Test By:		King Kong	
Humidity :		65 %				
Band	Channel Number	Channel Freq. (MHz)	Power Spectral Density		Limit	Verdict
			Ant0	Ant1		
UNII Band I	CH36	5180	1.620	2.210	≤9.49dBm/1MHz	Pass
	CH40	5200	2.033	2.216	≤9.49dBm/1MHz	Pass
	CH48	5240	1.014	1.162	≤9.49dBm/1MHz	Pass
UNII Band II-A	CH52	5260	1.318	1.146	≤9.49dBm/1MHz	Pass
	CH56	5280	1.935	1.696	≤9.49dBm/1MHz	Pass
	CH64	5320	1.032	1.031	≤9.49dBm/1MHz	Pass
UNII Band II-C	CH100	5500	2.190	2.401	≤9.49dBm/1MHz	Pass
	CH120	5600	2.441	2.188	≤9.49dBm/1MHz	Pass
	CH140	5700	1.493	1.511	≤9.49dBm/1MHz	Pass
UNII Band III	CH149	5745	-0.635	-0.839	≤28.49dBm/500K Hz	Pass
	CH157	5785	-0.919	-0.727	≤28.46dBm/500K Hz	Pass
	CH165	5825	-1.935	-1.826	≤28.46dBm/500K Hz	Pass
Note: N/A (Not Applicable)						

<input checked="" type="checkbox"/> 802.11n(VHT20) mode							
Temperature :		28	Test By:		King Kong		
Humidity :		65 %					
Band	Channel Number	Channel Freq. (MHz)	Power Spectral Density			Limit	Verdict
			Ant0	Ant1	Ant0+Ant1		
UNII Band I	CH36	5180	2.001	1.794	4.91	≤9.49dBm/1MHz	Pass
	CH40	5200	1.793	1.567	4.69	≤9.49dBm/1MHz	Pass
	CH48	5240	0.468	0.802	3.65	≤9.49dBm/1MHz	Pass
UNII Band II-A	CH52	5260	0.919	1.177	4.06	≤9.49dBm/1MHz	Pass
	CH56	5280	0.952	1.504	4.25	≤9.49dBm/1MHz	Pass
	CH64	5320	0.824	0.675	3.76	≤9.49dBm/1MHz	Pass
UNII Band II-C	CH100	5500	1.637	2.084	4.88	≤9.49dBm/1MHz	Pass
	CH120	5600	2.216	2.184	5.21	≤9.49dBm/1MHz	Pass
	CH140	5700	1.448	1.562	4.52	≤9.49dBm/1MHz	Pass
UNII Band III	CH149	5745	-1.119	-1.163	1.87	≤28.49dBm/500K Hz	Pass
	CH157	5785	-0.838	-1.085	2.05	≤28.46dBm/500K Hz	Pass
	CH165	5825	-2.315	-1.961	0.88	≤28.46dBm/500K Hz	Pass

802.11ac(VHT20) mode

Temperature : 28 Test By: King Kong
 Humidity : 65 %

Band	Channel Number	Channel Freq. (MHz)	Power Spectral Density			Limit	Verdict
			Ant0	Ant1	Ant0+Ant1		
UNII Band I	CH36	5180	1.497	1.444	4.48	≤9.49dBm/1MHz	Pass
	CH40	5200	1.230	1.807	4.54	≤9.49dBm/1MHz	Pass
	CH48	5240	0.530	0.485	3.52	≤9.49dBm/1MHz	Pass
UNII Band II-A	CH52	5260	0.585	0.787	3.70	≤9.49dBm/1MHz	Pass
	CH56	5280	1.140	1.025	4.09	≤9.49dBm/1MHz	Pass
	CH64	5320	0.643	0.854	3.76	≤9.49dBm/1MHz	Pass
UNII Band II-C	CH100	5500	1.577	1.691	4.64	≤9.49dBm/1MHz	Pass
	CH120	5600	2.282	1.978	5.14	≤9.49dBm/1MHz	Pass
	CH140	5700	0.999	1.322	4.17	≤9.49dBm/1MHz	Pass
UNII Band III	CH149	5745	-0.820	-1.385	1.92	≤28.49dBm/500K Hz	Pass
	CH157	5785	-1.285	-1.293	1.72	≤28.46dBm/500K Hz	Pass
	CH165	5825	-1.866	-2.097	1.03	≤28.46dBm/500K Hz	Pass

802.11n(VHT40) mode

Temperature : 28 Test By: King Kong
 Humidity : 65 %

Band	Channel Number	Channel Freq. (MHz)	Power Spectral Density			Limit	Verdict
			Ant0	Ant1	Ant0+Ant1		
UNII Band I	CH38	5190	-0.863	-0.468	2.35	≤9.49dBm/1MHz	Pass
	CH46	5230	-1.152	-1.389	1.74	≤9.49dBm/1MHz	Pass
UNII Band II-A	CH54	5270	-1.217	-1.172	1.82	≤9.49dBm/1MHz	Pass
	CH62	5310	-1.597	-1.448	1.49	≤9.49dBm/1MHz	Pass
UNII Band II-C	CH102	5510	-0.332	-0.597	2.55	≤9.49dBm/1MHz	Pass
	CH118	5590	-0.134	-0.065	2.91	≤9.49dBm/1MHz	Pass
	CH134	5670	-0.921	-0.907	2.10	≤9.49dBm/1MHz	Pass
UNII Band III	CH151	5755	-3.264	-3.562	-0.40	≤28.49dBm/500K Hz	Pass
	CH159	5795	-3.846	-3.682	-0.75	≤28.49dBm/500K Hz	Pass

