

Dongguan Dexinda Electronic Technology Co.,Ltd.

Client Dongguan Hankai Electronics Co., Ltd

TYPE A11 transmit coil

Model NO G50 Magnetic disc single hole double
slot back adhesive line length 7MM 6.5UH

Part numbering systey DXD2023041701

Cient p/NO 101.20.04140

Enginrer NO RAO 202304001

Date 2023-04-17

For Enginer Departner Only	
Rrvised Content	APPROved Date

Prepared

Checked

Approved

Rao Zhipeng

Xie Liang

Authorized Signaturure Company Chop		
Enginrer	QC APPROved	APPROved

一、 Winding Proceese:

NO	winding	wire gauge	number of turns	winding direction	notes
1	N1	2UEW-B-0.08*105P	10TS	CCW	
2					

二. FEATURES:

1. (Test conditions) : 25°C,65%RH@100KHz/1V

1.1 (Inductance)

1.11 L0A (Individual coil) =3.8uH±20%

1.12 L0A(Coil+magnetic disc)=6.5uH±10%

1.2 Q-value=70MIN

1.3 DC Resistance (DCR) : 45mΩ MAX

1.4 operation temperature(Operating Temperature): -25°C~85°C

2.(Test instrument): L:Chuangda 1068+1310;**DCR**:502BC;**SIZE**:Callipers

3.Material List

NO	Project	material
1	WIRE	φ 0.08*105p 2UEW-1.15mm
2	FERRITE	50*5.3*1.0 L Type slot ferrite hard magnetic
3	GLUE	White glue
4	SOLDER	XCD-907B
5	Adhesive	Double sided adhesive backing
6	High temperature adhesive	7MM High temperature adhesive tape
7	UL	E238500

8		
---	--	--



三. CIRCUIT DIAGRAM

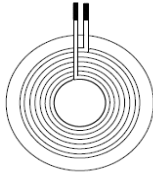

N1

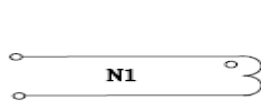

单位: MM

四. OUTSIDE DIAGRA

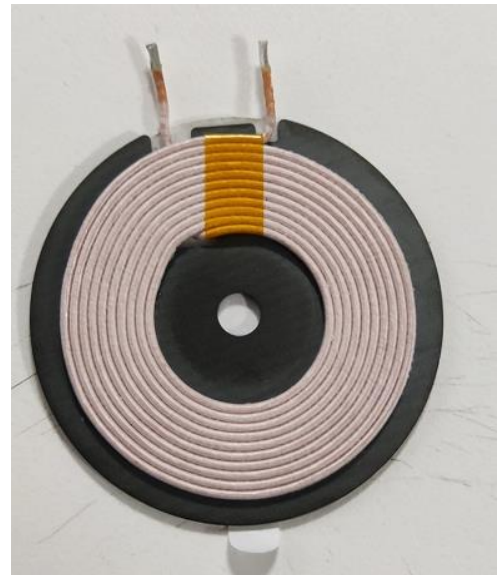
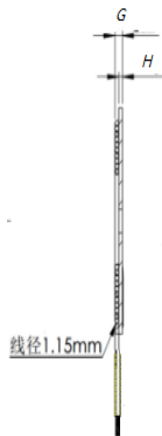
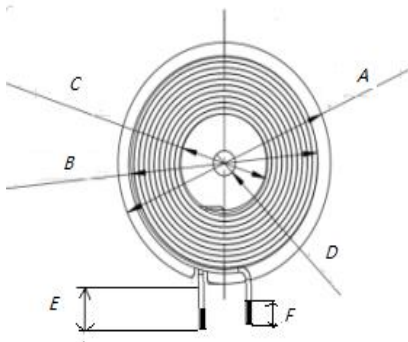

Note: Wrap 8MM (ref) high-temperature adhesive tape around the coil outlet position

standard	A	B	C	D	E	F	G	
STD	50.0±1	42.5±1.2	20.5±0.5	5±0.5	7±2	2-5	2.6Max	

unit: MM

五. PACKAGE

5.1 包装图片 Packing pictures:

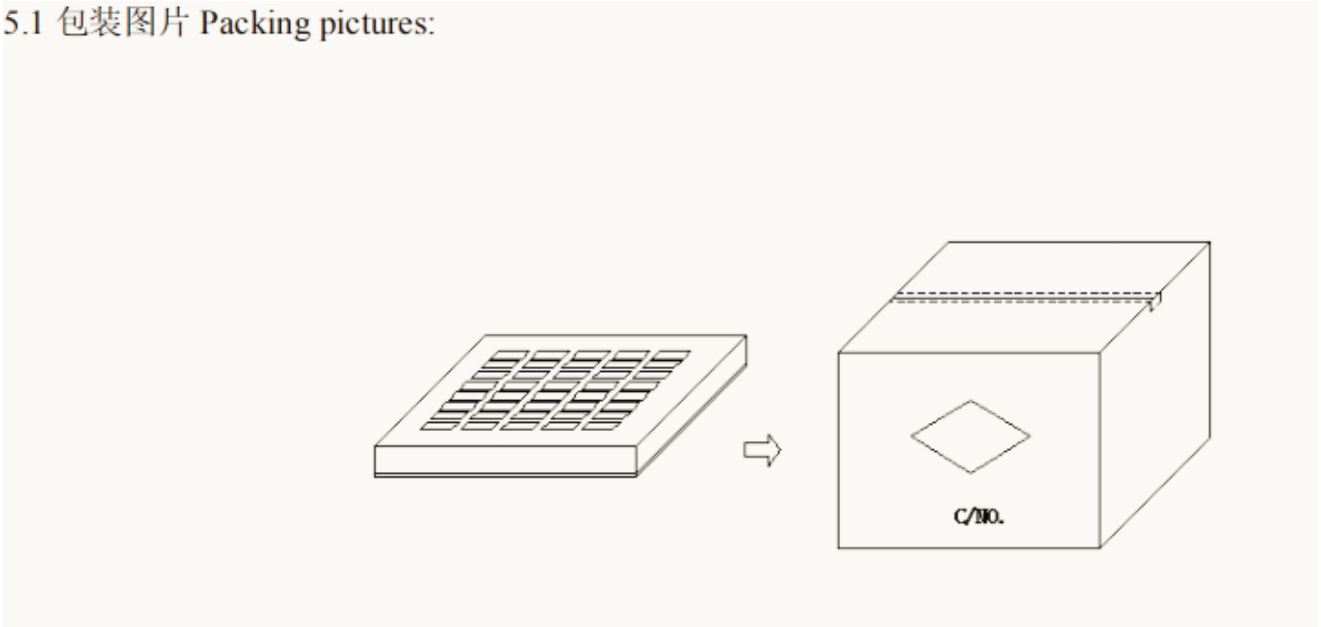

5.2 包装数量及规格 Packing Quantity:

项目 Item	数量 Quantity	材料规格 Material
盒 Box	350 Pcs	345*330*50 mm
箱 Big Carton	1400 Pcs	360*340*280 mm

5.3 *The packaging shall be based on the existing packing plate and the actual delivery package shall prevail .If there is any requirement,we can customize it.*

六、Storage and Use condition

6.1 Storage condition

6.1.1 Recommended keeping conditions: $-25^{\circ}\text{C} \sim 85^{\circ}\text{C}$, 70%RH (Max.)

6.1.2 Storage life : Within the limits of six months from being produced.

6.2 Use condition

Use condition limit: $T=-25^{\circ}\text{C} \sim 85^{\circ}\text{C}$, $\text{RH} \leq 90\%$.