

Dongguan Desinda Electronic Technology Co.,Ltd.

Ciient: Dongguan HANK Electronics.,LTD

Type: MP-A2 transmit coil

Model NO: G50 single hole double groove adhesive wire length
120MM 10UH

Part numbering systey: DXD20230904001

Cient p/NO: 101.20.05630

Date: 2023-9-04

For Enginer Departner Only	
Rrvised Cintent	APPproved Date

Prepared

Checked

Approved

Authorixed Signaturure Company Chop		
Engineer	QC APPproved	APPproved

Dongguan Desinda Electronic Technology Co.,Ltd.

01. Winding Procese:

No	Winding	Wire gauge	Number of turns	Winding direction	Notes
1	N1	2UEW-B-0.08*105P	12TS	CCW	
2					

02. FEATURES:

1. Test conditions: 25 ° C, 65% RH@100KHz /1V

1.1 Inductance

1.2 LOA (coil+magnet)=10uH+10%

1.2Q value=80MIN

1.3 DC resistance (DCR): 85m2 MAX

1.3 Operating Temperature: -25 ° C~85 ° C

2. Test instrument: L: Chuangda

CD1068+1310;DCR:502BC;SIZE:Callipers

3. Bill of Material

No	Project	Materials
1	WIRE	4 0.08*105p 2UEW-1.15mm
2	FERRITE	50*5.3*1.0 Ferrite hard magnet
3	GLUE	White glue
4	SOLDER	XCD-907B
5	Adhesive	3M Adhesive backing
6	High temperature adhesive	7MM High temperature adhesive tape

Dongguan Desinda Electronic Technology Co.,Ltd.

03. CIRCUIT DIAGRAM

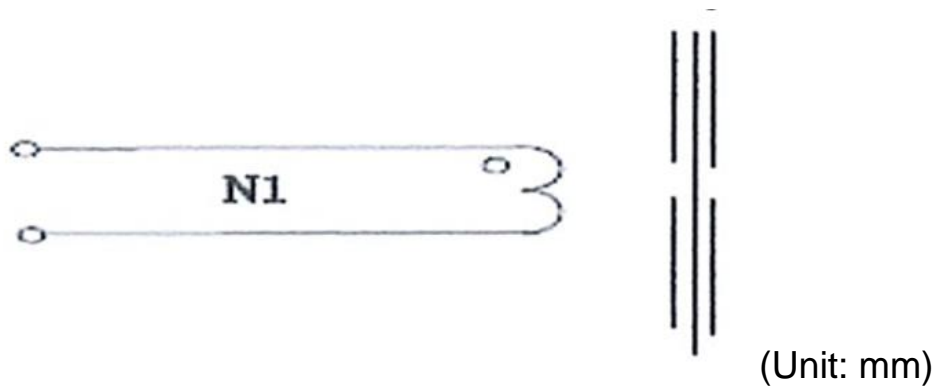

04. OUTSIDE DIAGRA

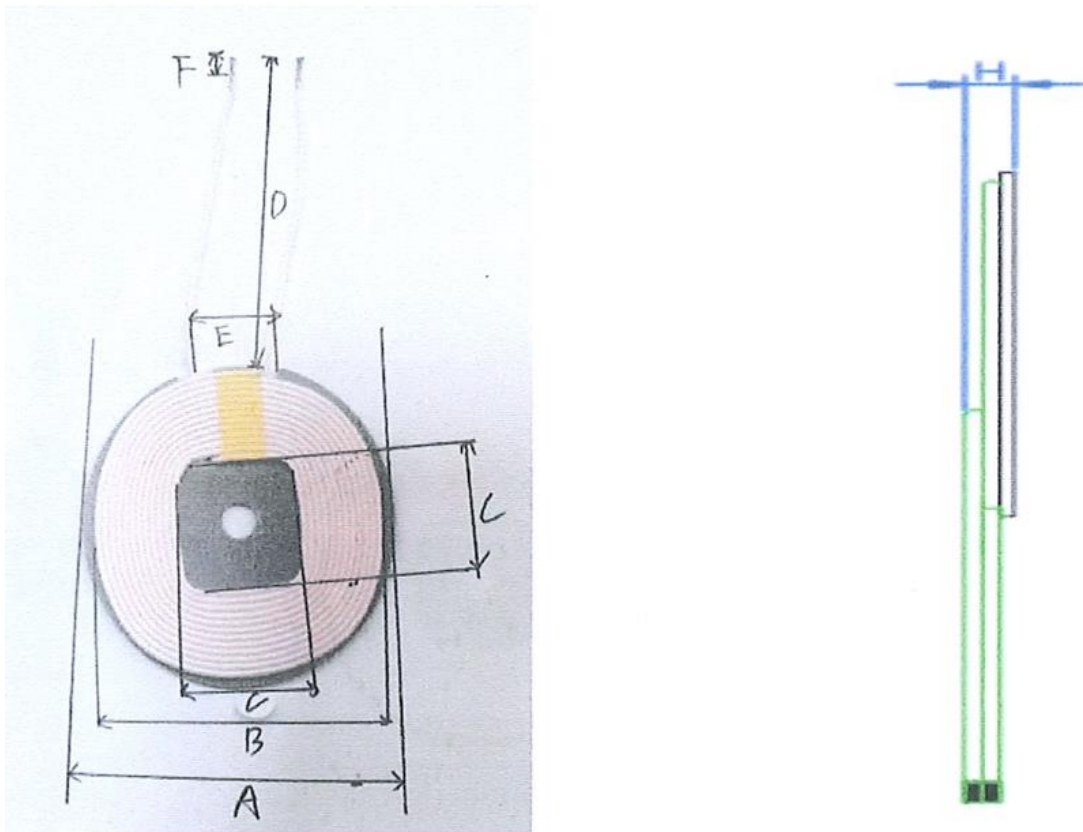

Note: Wrap 8MM (ref) high-temperature adhesive tape around the coil outlet position

Standard	A	B	C	D	E	F	H
STD	49.5±1	46±1	19.5±1	120±2	10±2	3±1.5	2.8Max

Dongguan Desinda Electronic Technology Co.,Ltd.

05. PACKAGE

5.1 Packing pictures:

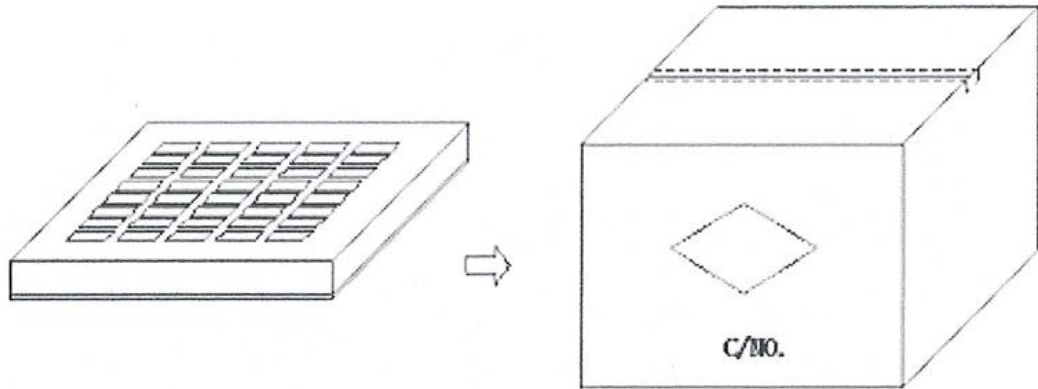

5.2 Packing Quantity:

Item	Quantity	Material
Box	350 Pcs	345*330*50mm
Big Carton	1750 PCS	360*340*280mm

5.3 The packaging shall be based on the existing packing plate and the actual delivery package shall prevail. If there is any requirement, we can customize it.