

# TEST REPORT

**Reference No.**..... : WTS19S02008883-2W  
**FCC ID** ..... : 2ANY6-TE390  
**Applicant**..... : Telo Systems Ltd.  
**Address**..... : Room 408, Chuangye Building, Seven-Star Park, Chuangye 2nd Road,  
Bao'an 28th District, Xin'an Bao'an District, Shenzhen, China  
**Manufacturer** ..... : The same as above  
**Address**..... : The same as above  
**Product**..... : Smart Phone  
**Model(s)** ..... : TE390  
**Brand Name**..... : Telo Systems  
**Standards**..... : FCC CFR47 Part 27: 2017  
**Date of Receipt sample** .... : 2019-02-22  
**Date of Test** ..... : 2019-02-23 to 2019-02-26  
**Date of Issue**..... : 2019-02-27  
**Test Result**..... : **Pass**  
**Remark**..... : This report is based on original report WTS18S08121909-6W V1 for  
added FDD band 13 by software.

**Remarks:**

The results shown in this test report refer only to the sample(s) tested, this test report cannot be reproduced, except in full, without prior written permission of the company. The report would be invalid without specific stamp of test institute and the signatures of compiler and approver.

**Prepared By:**

**Waltek Services (Shenzhen) Co., Ltd.**

**Address: 1/F., Fukangtai Building, West Baima Road, Songgang Street, Baoan District, Shenzhen, Guangdong, China**

**Tel :+86-755-83551033**

**Fax:+86-755-83552400**

Compiled by:

*Ford Wang*

Ford Wang / Project Engineer

Approved by:



*Philo Zhong*

Philo Zhong / Manager

## 2 Laboratories Introduction

**Waltek Services (Shenzhen) Co., Ltd** is a professional third-party testing and certification laboratory with multi-year product testing and certification experience, established strictly in accordance with ISO/IEC 17025 requirements, and accredited by ILAC (International Laboratory Accreditation Cooperation) member. A2LA (American Association for Laboratory Accreditation, the certification number is 4243.01) of USA, CNAS (China National Accreditation Service for Conformity Assessment, the registration number is L3110) of China. Meanwhile, Waltek has got recognition as registration and accreditation laboratory from EMSD (Electrical and Mechanical Services Department), and American Energy star, FCC (The Federal Communications Commission), CEC (California energy efficiency), ISED (Innovation, Science and Economic Development Canada). It's the strategic partner and data recognition laboratory of international authoritative organizations, such as Intertek (ETL-SEMKO), TÜV Rheinland, TÜV SÜD, etc.



Waltek Services (Shenzhen) Co., Ltd is one of the largest and the most comprehensive third party testing laboratory in China. Our test capability covered four large fields: safety test. Electro Magnetic Compatibility (EMC), and energy performance, wireless radio. As a professional, comprehensive, justice international test organization, we still keep the scientific and rigorous work attitude to help each client satisfy the international standards and assist their product enter into globe market smoothly.

**Test Facility:****A. Accreditations for Conformity Assessment (International)**

Country/Region	Scope Covered By	Scope	Note
USA	ISO/IEC 17025	FCC ID \ DOC \ VOC	1
Canada		IC ID \ VOC	2
Japan		MIC-T \ MIC-R	-
Europe		EMCD \ RED	-
Taiwan		NCC	-
Hong Kong		OFCA	-
Australia		RCM	-
India		WPC	-
Thailand		NTC	-
Singapore		IDA	-
Note: 1. FCC Designation No.: CN1201. Test Firm Registration No.: 523476. 2. ISED CAB identifier: CN0013			

**B. TCBs and Notify Bodies Recognized Testing Laboratory.**

Recognized Testing Laboratory of ...	Notify body number
TUV Rheinland	Optional.
Intertek	
TUV SUD	
SGS	
Phoenix Testlab GmbH	0700
Element Materials Technology Warwick Ltd	0891
Timco Engineering, Inc.	1177
Eurofins Product Service GmbH	0681

### 3 Contents

	<b>Page</b>
<b>1 COVER PAGE</b> .....	<b>1</b>
<b>2 LABORATORIES INTRODUCTION</b> .....	<b>2</b>
<b>3 CONTENTS</b> .....	<b>4</b>
<b>4 REVISION HISTORY</b> .....	<b>6</b>
<b>5 GENERAL INFORMATION</b> .....	<b>7</b>
5.1 GENERAL DESCRIPTION OF E.U.T. ....	7
5.2 DETAILS OF E.U.T. ....	7
5.3 TEST MODE.....	8
<b>6 TEST SUMMARY</b> .....	<b>9</b>
<b>7 EQUIPMENT USED DURING TEST</b> .....	<b>10</b>
7.1 EQUIPMENTS LIST.....	10
7.2 MEASUREMENT UNCERTAINTY.....	11
7.3 TEST EQUIPMENT CALIBRATION.....	11
<b>8 RF OUTPUT POWER</b> .....	<b>12</b>
8.1 EUT OPERATION.....	12
8.2 TEST PROCEDURE.....	12
8.3 TEST RESULT.....	13
<b>9 PEAK-TO-AVERAGE RATIO</b> .....	<b>17</b>
9.1 EUT OPERATION.....	17
9.2 TEST PROCEDURE.....	17
9.3 TEST RESULT.....	17
<b>10 BANDWIDTH</b> .....	<b>18</b>
10.1 EUT OPERATION.....	18
10.2 TEST PROCEDURE.....	18
10.3 TEST RESULT.....	19
<b>11 SPURIOUS EMISSIONS AT ANTENNA TERMINALS</b> .....	<b>22</b>
11.1 EUT OPERATION.....	22
11.2 TEST PROCEDURE.....	22
11.3 TEST RESULT.....	22
<b>12 SPURIOUS RADIATED EMISSIONS</b> .....	<b>23</b>
12.1 EUT OPERATION.....	23
12.2 TEST SETUP.....	23
12.3 SPECTRUM ANALYZER SETUP.....	24
12.4 TEST PROCEDURE.....	25
12.5 SUMMARY OF TEST RESULTS.....	26
<b>13 BAND EDGE MEASUREMENT</b> .....	<b>27</b>
13.1 EUT OPERATION.....	27
13.2 TEST PROCEDURE.....	27
13.3 TEST RESULT.....	28
<b>14 FREQUENCY STABILITY</b> .....	<b>29</b>
14.1 EUT OPERATION.....	29
14.2 TEST PROCEDURE.....	29
14.3 TEST RESULT.....	30

<b>15</b>	<b>RF EXPOSURE.....</b>	<b>31</b>
<b>16</b>	<b>PHOTOGRAPHS OF TEST SETUP AND EUT.....</b>	<b>32</b>

#### 4 Revision History

Test report No.	Date of Receipt sample	Date of Test	Date of Issue	Purpose	Comment	Approved
WTS19S02008 883-2W	2019-02-22	2019-02-23 to 2019-02- 26	2019-02-27	original	-	Valid

## 5 General Information

### 5.1 General Description of E.U.T.

Product:	Smart Phone
Model(s):	TE390
Model Description:	N/A
GSM Band(s):	GSM 850/900/1800/1900MHz
GPRS/EGPRS Class:	12
WCDMA Band(s):	FDD Band II/IV/V
LTE Band(s):	FDD Band 2/4/5/7/12/13/17
Wi-Fi Specification:	2.4G-802.11b/g/n HT20/n HT40 5G-802.11a/n HT20/n HT40
Bluetooth Version:	Bluetooth v4.0 with BLE
GPS:	Support
NFC:	N/A
Hardware Version:	R886_MB_V2.0_20180112
Software Version:	TE390_US_V4_20180818
Highest frequency (Exclude Radio):	1.25GHz
Storage Location:	Internal Storage
Note:	N/A

### 5.2 Details of E.U.T.

Operation Frequency:	LTE Band 13: 777~787MHz
Max. RF output power:	LTE Band 13: 21.92dBm
Type of Modulation:	LTE: QPSK, 16QAM
Antenna installation:	LTE: internal permanent antenna
Antenna Gain:	LTE Band 13: 0.8dBi
Ratings:	Battery DC 3.8V, 3600mAh DC 5V, 2.0A, charging from adapter (Adapter Input: 100-240V~50/60Hz 0.3A)
Adapter:	Manufacturer: Shen zhen Mao Two Power Co.,Ltd. Model No.: MR-0502000US
Type of Emission:	LTE Band 13 5MHz: 4M54G7D(QPSK), 4M53W7D(16QAM) LTE Band 13 10 MHz: 8M97G7D(QPSK), 8M94W7D(16QAM)

### 5.3 Test Mode

All test mode(s) and condition(s) mentioned were considered and evaluated respectively by performing full tests, the worst data were recorded and reported.

Support Band	Test Mode BW(MHz)	Channel Frequency	Channel Number
LTE Band 13	5	779.5 MHz	23205
		782.0 MHz	23230
		784.5 MHz	23255
	10	782.0 MHz	23230
Remark: All mode(s) were tested and the worst data was recorded.			



## 6 Test Summary

Test Items	Test Requirement	Result
RF Output Power	27.50(d.4)	PASS
Peak-to-Average Ratio	27.50(d)	PASS
Bandwidth	27.53(a)	PASS
Spurious Emissions at Antenna Terminal	27.53(h) 27.53(m)(4)	PASS
Field Strength of Spurious Radiation	27.53(h) 27.53(m)(4)	PASS
Out of band emission	27.53(h) 27.53(m)(4)	PASS
Frequency Stability	27.5(h) 27.54	PASS
Maximum Permissible Exposure (SAR)	1.1307 2.1093	PASS

## 7 Equipment Used during Test

### 7.1 Equipments List

Conducted Emissions Test Site 1#						
Item	Equipment	Manufacturer	Model No.	Serial No.	Last Calibration Date	Calibration Due Date
1.	EMI Test Receiver	R&S	ESCI	100947	2018-09-12	2019-09-11
2.	LISN	R&S	ENV216	101215	2018-09-12	2019-09-11
3.	Cable	Top	TYPE16(3.5M)	-	2018-09-12	2019-09-11
Conducted Emissions Test Site 2#						
Item	Equipment	Manufacturer	Model No.	Serial No.	Last Calibration Date	Calibration Due Date
1.	EMI Test Receiver	R&S	ESCI	101155	2018-09-12	2019-09-11
2.	LISN	SCHWARZBECK	NSLK 8128	8128-289	2018-09-12	2019-09-11
3.	Limiter	York	MTS-IMP-136	261115-001-0024	2018-09-12	2019-09-11
4.	Cable	LARGE	RF300	-	2018-09-12	2019-09-11
3m Semi-anechoic Chamber for Radiation Emissions Test site 1#						
Item	Equipment	Manufacturer	Model No.	Serial No.	Last Calibration Date	Calibration Due Date
1	Spectrum Analyzer	R&S	FSP	100091	2018-04-29	2019-04-28
2	Active Loop Antenna	Beijing Dazhi	ZN30900A	-	2018-04-09	2019-04-08
3	Trilog Broadband Antenna	SCHWARZBECK	VULB9163	336	2018-04-09	2019-04-08
4	Coaxial Cable (below 1GHz)	Top	TYPE16(13M)	-	2018-09-12	2019-09-11
5	Broad-band Horn Antenna	SCHWARZBECK	BBHA 9120 D	667	2018-04-09	2019-04-08
6	Broad-band Horn Antenna	SCHWARZBECK	BBHA 9170	335	2018-04-09	2019-04-08
7	Broadband Preamplifier	COMPLIANCE DIRECTION	PAP-1G18	2004	2018-04-13	2019-04-12
8	Coaxial Cable (above 1GHz)	Top	1GHz-25GHz	EW02014-7	2018-04-13	2019-04-12
9	Signal Generator	R&S	SMR20	100046	2018-09-12	2019-09-11
10	Smart Antenna	SCHWARZBECK	HA08	-	2018-04-09	2019-04-08
3m Semi-anechoic Chamber for Radiation Emissions Test site 2#						
Item	Equipment	Manufacturer	Model No.	Serial No	Last Calibration Date	Calibration Due Date
1	Test Receiver	R&S	ESCI	101296	2018-04-13	2019-04-12
2	Trilog Broadband Antenna	SCHWARZBECK	VULB9160	9160-3325	2018-04-09	2019-04-08

3	Amplifier	Compliance pirection systems inc	PAP-0203	22024	2018-04-13	2019-04-12
4	Cable	HUBER+SUHNER	CBL2	525178	2018-04-13	2019-04-12
<b>RF Conducted Testing</b>						
Item	Equipment	Manufacturer	Model No.	Serial No.	Last Calibration Date	Calibration Due Date
1.	EMC Analyzer (9k~26.5GHz)	Agilent	E7405A	MY45114943	2018-09-12	2019-09-11
2.	Spectrum Analyzer	Agilent	N9020A	MY49100060	2018-09-12	2019-09-11
3.	Universal Radio Communication Tester	R&S	CMW 500	127818	2018-04-13	2019-04-12
4	Signal Analyzer (9k~26.5GHz)	Agilent	N9010A	MY50520207	2018-09-12	2019-09-11

## 7.2 Measurement Uncertainty

Parameter	Uncertainty
Conducted Emission	± 3.64 dB(AC mains 150KHz~30MHz)
Radiated Spurious Emissions	± 5.08 dB (Bilog antenna 30M~1000MHz)
	± 5.47 dB (Horn antenna 1000M~25000MHz)
Radio Frequency	± 1 x 10 <sup>-7</sup> Hz
RF Power	± 0.42 dB
RF Power Density	± 0.7dB
Conducted Spurious Emissions	± 2.76 dB (9kHz~26500MHz)
Confidence interval: 95%. Confidence factor:k=2	

## 7.3 Test Equipment Calibration

All the test equipments used are valid and calibrated by CEPREI Certification Body that address is No.110 Dongguan Zhuang RD. Guangzhou, P.R.China.

## 8 RF OUTPUT POWER

Test Requirement:	FCC Part 2.1046, 27.50(h.2); 27.50(d.4)
Test Method:	TIA/EIA-603-D:2010 KDB971168 D01 v03
Test Mode:	TX transmitting

### 8.1 EUT Operation

Operating Environment :

Temperature:	22.5 °C
Humidity:	52.1 % RH
Atmospheric Pressure:	101.2kPa

### 8.2 Test Procedure

Conducted method:

The RF output of the transmitter was connected to the wireless test set and the spectrum analyzer through sufficient attenuation.

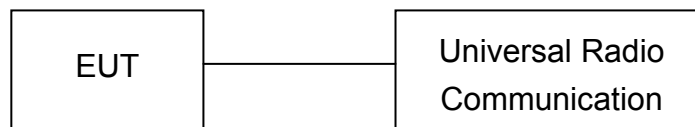

Radiated method:

1. The setup of EUT is according with per TIA/EIA Standard 603D:2010.
2. The measurement antenna was placed at a distance of 3 meters from the EUT. During the tests, the antenna height and polarization as well as EUT azimuth were varied in order to identify the maximum level of emissions from the EUT. The test was performed by placing the EUT on 3-orthogonal axis.
3. The frequency range up to tenth harmonic of the fundamental frequency was investigated.
4. Remove the EUT and replace it with substitution antenna. A signal generator was connected to the substitution antenna by a non-radiating cable. The absolute levels of the spurious emissions were measured by the substitution.

## 8.3 Test Result

## Conducted Power

LTE Band 13:

BW(MHz)	Ch	Freq(MHz)	Mode	UL RB Allocation	UL RB Offset	Average Power (dbm)	Tune up limited(dBm)	MPR (dB)
5MHz	23205	779.5	QPSK	1	0	21.7	21.0±1	/
				1	49	21.82	21.0±1	/
				1	99	21.78	21.0±1	/
				12	0	20.86	20.0±1	1.0
				12	24	20.86	20.0±1	1.0
				12	49	20.84	20.0±1	1.0
			16QAM	25	0	20.8	20.0±1	1.0
				1	0	20.89	20.0±1	1.0
				1	49	20.94	20.0±1	1.0
				1	99	20.92	20.0±1	1.0
				12	0	20.03	20.0±1	1.0
				12	24	20.07	20.0±1	1.0
				12	49	20.07	20.0±1	1.0
				25	0	19.92	20.0±1	1.0
				23230	782.0	QPSK	1	0
	1	49	21.7				21.0±1	/
	1	99	21.53				21.0±1	/
	12	0	20.84				20.0±1	1.0
	12	24	20.76				20.0±1	1.0
	12	49	20.72				20.0±1	1.0
	16QAM	25	0			20.73	20.0±1	1.0
		1	0			20.97	20.0±1	1.0
		1	49			20.9	20.0±1	1.0
		1	99			20.76	20.0±1	1.0
		12	0			19.99	20.0±1	1.0
		12	24			19.89	20.0±1	1.0
		12	49			19.8	20.0±1	1.0
		25	0			19.72	20.0±1	1.0
		23255	784.5			QPSK	1	0
	1			49	21.53		21.0±1	/
1	99			21.47	21.0±1		/	
12	0			20.71	20.0±1		1.0	
12	24			20.57	20.0±1		1.0	
12	49			20.55	20.0±1		1.0	
16QAM	25			0	20.59	20.0±1	1.0	
	1			0	20.95	20.0±1	1.0	
	1			49	20.73	20.0±1	1.0	
	1			99	20.61	20.0±1	1.0	
	12			0	19.84	20.0±1	1.0	
	12			24	19.73	20.0±1	1.0	

				12	49	19.71	20.0±1	1.0
				25	0	19.67	20.0±1	1.0

BW(MHz)	Ch	Freq(MHz)	Mode	UL RB Allocation	UL RB Offset	Average Power (dbm)	Tune up limited(dBm)	MPR (dB)
10MHz	23230	782.0	QPSK	1	0	21.87	21.0±1	/
				1	49	21.92	21.0±1	/
				1	99	21.46	21.0±1	/
				25	0	20.81	20.0±1	1.0
				25	24	20.98	20.0±1	1.0
				25	49	20.6	20.0±1	1.0
				50	0	20.7	20.0±1	1.0
			16QAM	1	0	20.69	20.0±1	1.0
				1	49	20.72	20.0±1	1.0
				1	99	20.37	20.0±1	1.0
				25	0	19.93	20.0±1	1.0
				25	24	19.84	20.0±1	1.0
				25	49	19.68	20.0±1	1.0
				50	0	19.75	20.0±1	1.0

**ERP and EIRP****LTE Band 13**

Frequency	Receiver Reading	Turn table Angle	RX Antenna		Substituted			Absolute Level	Part 27	
			Height	Polar	SG Level	Cable	Antenna Gain		Limit	Margin
(MHz)	(dBμV)	Degree	(m)	(H/V)	(dBm)	(dB)	(dB)	(dBm)	(dBm)	(dB)
LTE Band 13 Channel 23205 – 5MHz – QPSK										
779.50	93.95	322	1.6	H	22.95	0.20	0.00	22.75	34.77	-12.02
779.50	94.97	160	1.8	V	22.69	0.20	0.00	22.49	34.77	-12.28
LTE Band 13 Channel 23230 – 5MHz – QPSK										
782.00	94.05	183	1.9	H	23.05	0.20	0.00	<b>22.85</b>	34.77	-11.92
782.00	94.99	346	1.0	V	22.71	0.20	0.00	22.51	34.77	-12.26
LTE Band 13 Channel 23255 – 5MHz – QPSK										
784.50	93.88	155	1.5	H	22.88	0.20	0.00	22.68	34.77	-12.09
784.50	95.02	230	1.9	V	22.74	0.20	0.00	22.54	34.77	-12.23
LTE Band 13 Channel 23205 – 5MHz – 16QAM										
779.50	93.87	218	2.0	H	22.87	0.20	0.00	22.67	34.77	-12.10
779.50	95.08	288	2.1	V	22.80	0.20	0.00	<b>22.60</b>	34.77	-12.17
LTE Band 13 Channel 23230 – 5MHz – 16QAM										
782.00	93.89	172	2.4	H	22.89	0.20	0.00	22.69	34.77	-12.08
782.00	95.04	332	1.6	V	22.76	0.20	0.00	22.56	34.77	-12.21
LTE Band 13 Channel 23255 – 5MHz – 16QAM										
784.50	93.86	86	1.4	H	22.86	0.20	0.00	22.66	34.77	-12.11
784.50	95.08	200	1.1	V	22.80	0.20	0.00	<b>22.60</b>	34.77	-12.17
LTE Band 13 Channel 23230 – 10MHz – QPSK										
782.00	93.85	206	1.8	H	22.85	0.20	0.00	<b>22.65</b>	34.77	-12.12
782.00	95.02	212	1.4	V	22.74	0.20	0.00	22.54	34.77	-12.23
LTE Band 13 Channel 23230 – 10MHz – 16QAM										
782.00	93.80	191	2.3	H	22.80	0.20	0.00	22.60	34.77	-12.17
782.00	95.03	63	1.1	V	22.75	0.20	0.00	<b>22.55</b>	34.77	-12.22



## 9 Peak-to-Average Ratio

Test Requirement:	27.50(d)
Test Method:	N/A
Test Mode:	TX transmitting

### 9.1 EUT Operation

Operating Environment :

Temperature:	22.5 °C
Humidity:	52.3% RH
Atmospheric Pressure:	101.2kPa

### 9.2 Test Procedure

1. The EUT was connected to spectrum analyzer and system simulator via a power divider.
2. Set EUT to transmit at maximum output power.
3. When the duty cycle is less than 98%, then signal gating will be implemented on the spectrum analyzer by triggering from the system simulator.
4. Set the CCDF (Complementary Cumulative Distribution Function) option of the spectrum analyzer. Record the maximum PAPR level associated with a probability of 0.1%.

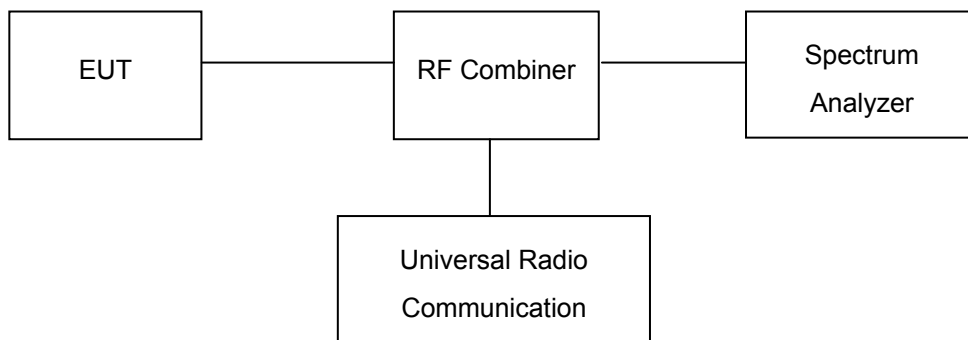

### 9.3 Test Result

PASS

#### LTE Band

Please refer to the Appendix Band 13 LTE Peak to Average Ratio.

## 10 BANDWIDTH

Test Requirement:	FCC Part 2.1049, 27.53(a)
Test Method:	TIA/EIA-603-D:2010 KDB971168 D01 v03
Test Mode:	TX transmitting

### 10.1 EUT Operation

Operating Environment :

Temperature:	22.5 °C
Humidity:	52.3% RH
Atmospheric Pressure:	101.2kPa

### 10.2 Test Procedure

The RF output of the transmitter was connected to the wireless test set and the spectrum analyzer through sufficient attenuation.

The resolution bandwidth of the spectrum analyzer was set in the range of 1 to 5 % of the anticipated OBW and the 26 dB & 99%bandwidth was recorded.

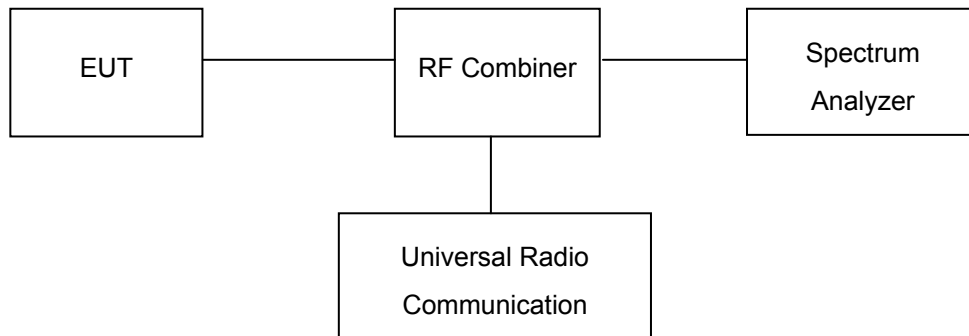

### 10.3 Test Result

BW(MHz)	Channel	Frequency (MHz)	Modulation	99% Occupied Bandwidth (MHz)	26 dB Bandwidth (MHz)
5	23205	779.5	QPSK	4.51	4.94
			16QAM	4.52	4.99
5	23230	782.0	QPSK	4.52	4.99
			16QAM	4.53	4.99
5	23255	784.5	QPSK	4.54	4.98
			16QAM	4.52	4.99
10	23230	782.0	QPSK	8.97	9.73
			16QAM	8.94	9.66

Test Plots

LTE Band 13 (Part 27)

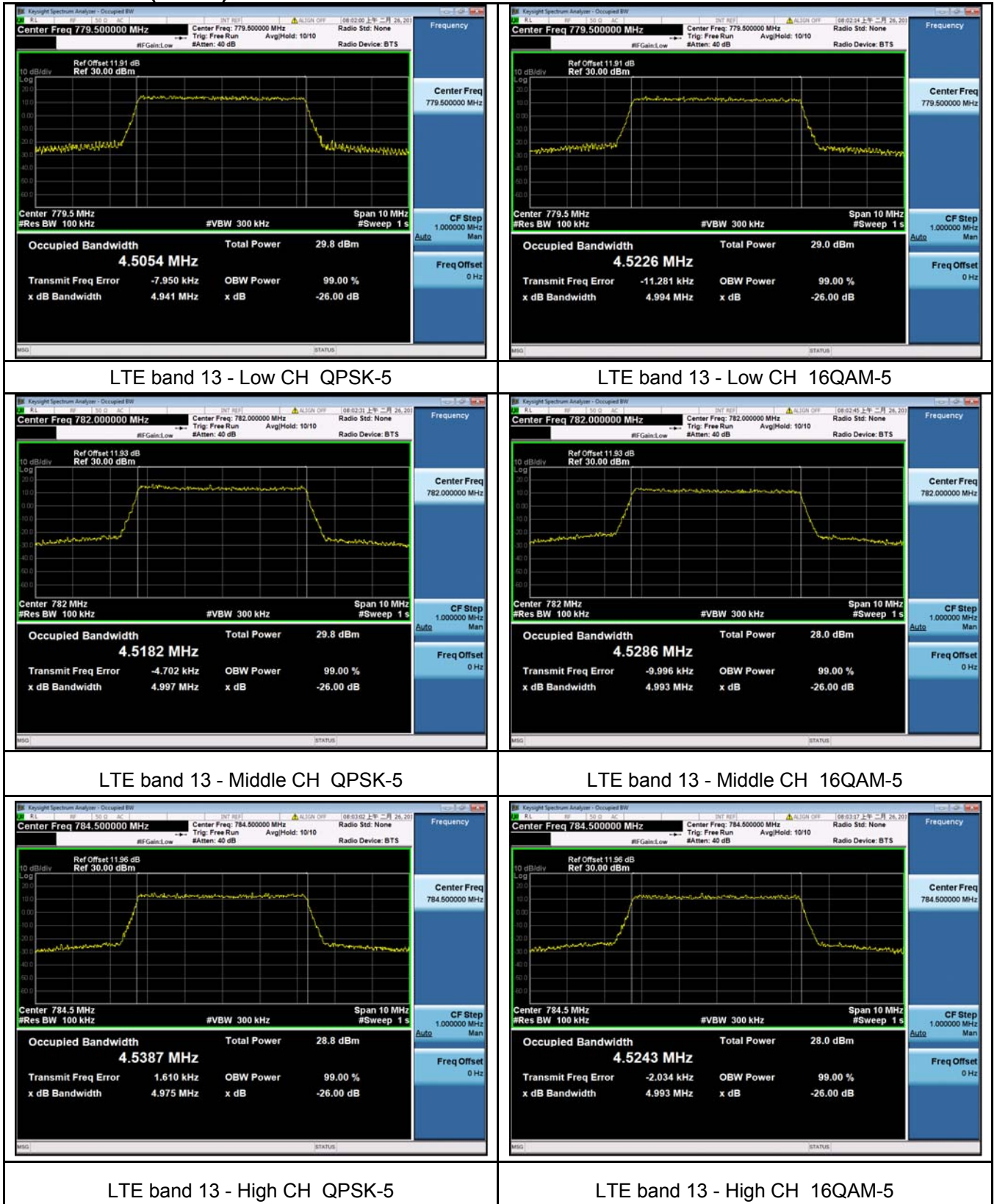

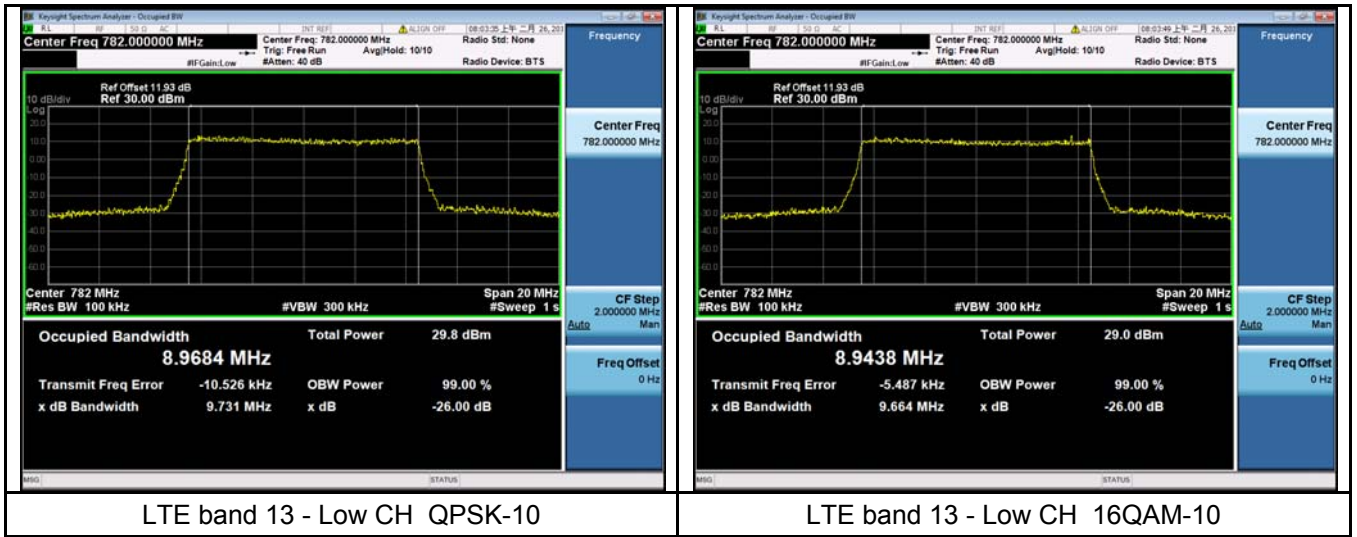

## 11 SPURIOUS EMISSIONS AT ANTENNA TERMINALS

Test Requirement:	FCC Part 2.1051, 27.53(h), 27.53(m)(4)
Test Method:	TIA/EIA-603-D:2010 KDB971168 D01 v03
Test Mode:	TX transmitting

### 11.1 EUT Operation

Operating Environment :

Temperature:	23.5 °C
Humidity:	52.1 % RH
Atmospheric Pressure:	101.3kPa

### 11.2 Test Procedure

The RF output of the transceiver was connected to a spectrum analyzer and simulator through appropriate attenuation. The resolution bandwidth of the spectrum analyzer was set at 1MHz. Sufficient scans were taken to show any out of band emissions up to 10th harmonics.

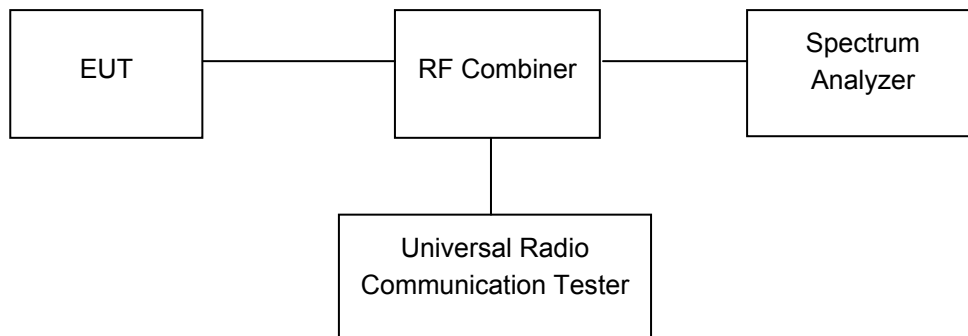

### 11.3 Test Result

PASS

#### LTE Band

Please refer to the Appendix Band 13 LTE Transmitter Spurious Emissions.

## 12 SPURIOUS RADIATED EMISSIONS

Test Requirement:	FCC Part 2.1053, 27.53(h), 27.53(m)(4)
Test Method:	TIA/EIA-603-D:2010 KDB971168 D01 v03
Test Mode:	TX transmitting

### 12.1 EUT Operation

Operating Environment :	
Temperature:	23.5 °C
Humidity:	52.1 % RH
Atmospheric Pressure:	101.2kPa

### 12.2 Test Setup

The radiated emission tests were performed in the 3m Semi- Anechoic Chamber test site. The test setup for emission measurement from 30 MHz to 1 GHz.

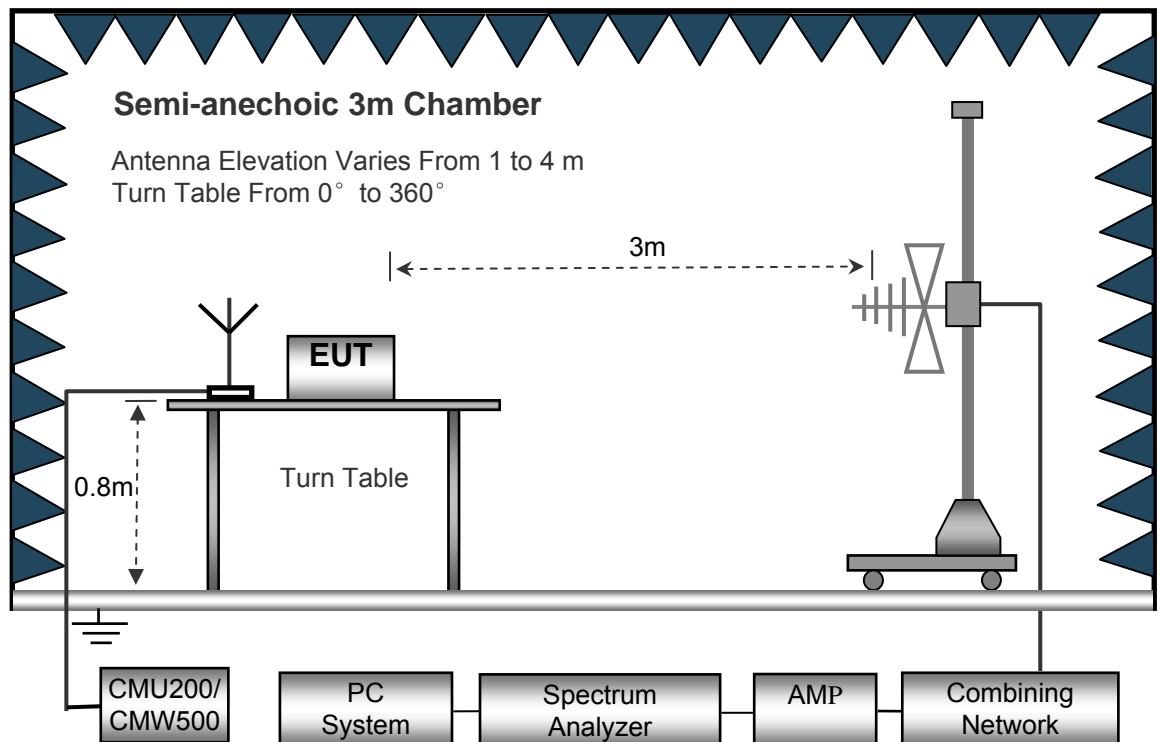

The test setup for emission measurement above 1 GHz.

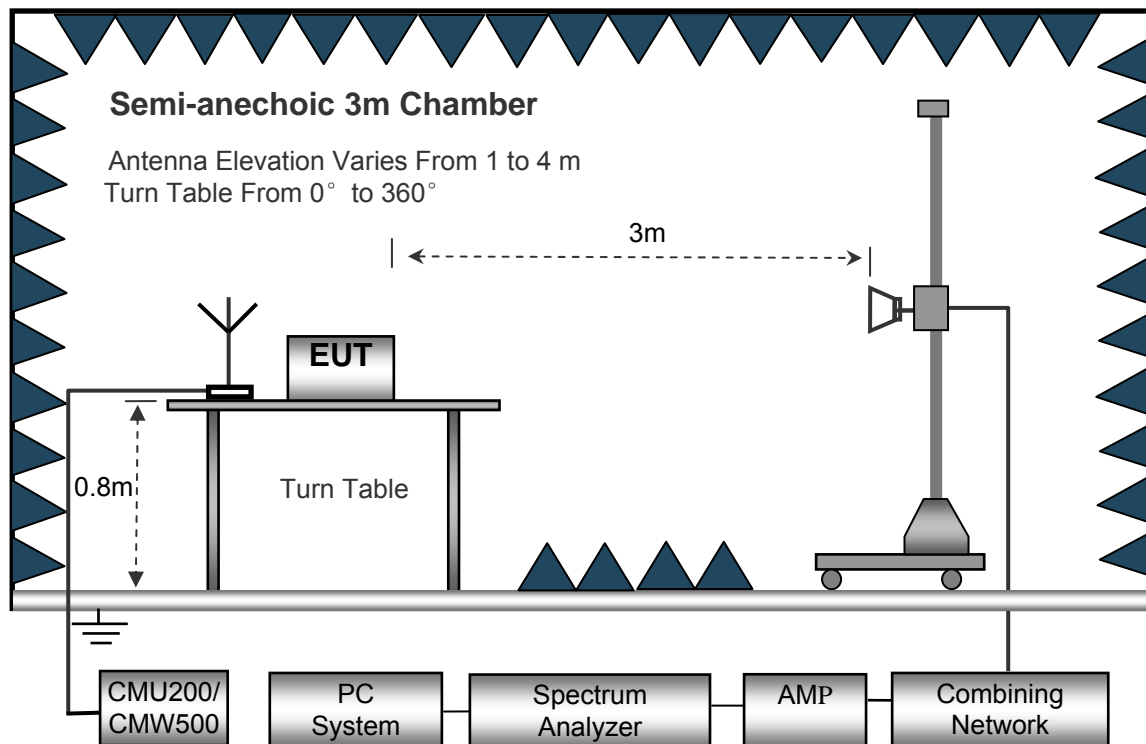

### 12.3 Spectrum Analyzer Setup

30MHz ~ 1GHz

Sweep Speed ..... Auto  
 Detector ..... PK  
 Resolution Bandwidth..... 100kHz  
 Video Bandwidth..... 300kHz

Above 1GHz

Sweep Speed ..... Auto  
 Detector ..... PK  
 Resolution Bandwidth..... 1MHz  
 Video Bandwidth..... 3MHz  
 Detector ..... Ave.  
 Resolution Bandwidth..... 1MHz  
 Video Bandwidth..... 10Hz



## 12.4 Test Procedure

1. The EUT is placed on a turntable, which is 0.8m above ground plane.
2. The turntable shall be rotated for 360 degrees to determine the position of maximum emission level.
3. EUT is set 3m away from the receiving antenna, which is moved from 1m to 4m to find out the maximum emissions. The spectrum was investigated from 30MHz up to the tenth harmonic of the highest fundamental frequency.
4. Maximum procedure was performed on the six highest emissions to ensure EUT compliance.
5. And also, each emission was to be maximized by changing the polarization of receiving antenna both horizontal and vertical.
6. The radiation measurements are tested under 3-axes(X,Y,Z) position(X denotes lying on the table, Y denotes side stand and Z denotes vertical stand), After pre-test, It was found that the worse radiation emission was get at the Z position. So the data shown was the Z position only.
7. Remove the EUT and replace it with substitution antenna. A signal generator was connected to the substitution antenna by a non-radiating cable. The absolute levels of the spurious emissions were measured by the substitution.  
Spurious emissions in dB =  $10 \lg (\text{TXpwr in Watts}/0.001)$  – the absolute level  
Spurious attenuation limit in dB =  $43 + 10 \text{Log}10 (\text{power out in Watts})$
8. Repeat above procedures until the measurements for all frequencies are completed.

## 12.5 Summary of Test Results

Remark: Test performed from 30MHz to 10<sup>th</sup> harmonics with low/middle/high channels, only the worst data were recorded.

### LTE Band 13

Frequency	Receiver Reading	Turn table Angle	RX Antenna		Substituted			Absolute Level	Result	
			Height	Polar	SG Level	Cable	Antenna Gain		Limit	Margin
(MHz)	(dBμV)	Degree	(m)	(H/V)	(dBm)	(dB)	(dB)	(dBm)	(dBm)	(dB)
LTE BAND 13 Channel 23205										
219.42	39.67	241	2.1	H	-70.84	0.15	0.00	-70.99	-25.00	-45.99
219.42	30.25	83	1.2	V	-77.34	0.15	0.00	-77.49	-25.00	-52.49
5455.00	65.95	93	1.6	H	-43.29	2.79	12.70	-33.38	-25.00	-8.38
5455.00	59.98	235	1.4	V	-48.79	2.79	12.70	-38.88	-25.00	-13.88
7908.50	53.58	134	1.7	H	-52.96	3.12	11.50	-44.58	-25.00	-19.58
7908.50	44.73	291	1.8	V	-60.70	3.12	11.50	-52.32	-25.00	-27.32
LTE BAND 13 Channel 23230										
219.42	38.78	46	1.1	H	-71.73	0.15	0.00	-71.88	-25.00	-46.88
219.42	30.97	272	1.1	V	-76.62	0.15	0.00	-76.77	-25.00	-51.77
5472.00	59.94	321	1.1	H	-49.30	2.37	12.50	-39.17	-25.00	-14.17
5472.00	52.80	149	2.0	V	-55.97	2.37	12.50	-45.84	-25.00	-20.84
7920.00	47.33	159	1.6	H	-59.21	3.12	11.50	-50.83	-25.00	-25.83
7920.00	38.16	293	1.1	V	-67.27	3.12	11.50	-58.89	-25.00	-33.89
LTE BAND 13 Channel 23255										
219.42	38.33	185	1.5	H	-72.18	0.15	0.00	-72.33	-25.00	-47.33
219.42	29.99	201	1.8	V	-77.60	0.15	0.00	-77.75	-25.00	-52.75
5500.00	53.20	37	2.1	H	-56.21	2.37	12.50	-46.08	-25.00	-21.08
5500.00	45.02	167	1.4	V	-63.75	2.37	12.50	-53.62	-25.00	-28.62
7940.00	40.59	233	1.9	H	-64.64	3.12	11.50	-56.26	-25.00	-31.26
7940.00	31.71	344	1.8	V	-73.18	3.12	11.50	-64.80	-25.00	-39.80

Note: 1) Absolute Level = SG Level - Cable loss + Antenna Gain

2) Margin = Absolute Level - Limit

## 13 Band Edge Measurement

Test Requirement:	FCC Part 2.1051, 27.53(h), 27.53(m)(4)
Test Method:	TIA/EIA-603-D:2010 KDB971168 D01 v03
Test Mode:	TX transmitting

### 13.1 EUT Operation

Operating Environment :

Temperature:	23.5 °C
Humidity:	52.3 % RH
Atmospheric Pressure:	101.3kPa

### 13.2 Test Procedure

The RF output of the transmitter was connected to the input of the spectrum analyzer through sufficient attenuation.

According to FCC Part 22.917(a), the power of any emissions outside of the authorized operating frequency ranges must be attenuated below the TX transmitting power (P) by a factor of at least  $43 + 10 \log(P)$  dB.

According to FCC Part 24.238(a), the power of any emissions outside of the authorized operating frequency ranges must be attenuated below the TX transmitting power (P) by a factor of at least  $43 + 10 \log(P)$  dB.

According to FCC Part 27.53(h), Except as otherwise specified below, for operations in the 1695-1710 MHz, 1710-1755 MHz, 1755-1780 MHz, 1915-1920 MHz, 1995-2000 MHz, 2000-2020 MHz, 2110-2155 MHz, 2155-2180 MHz, and 2180-2200 bands, the power of any emission outside a licensee's frequency block shall be attenuated below the transmitter power (P) in watts by at least  $43 + 10 \log_{10}(P)$  dB.

According to FCC Part 27.53(m)(4), For mobile digital stations, the attenuation factor shall be not less than  $40 + 10 \log(P)$  dB on all frequencies between the channel edge and 5 megahertz from the channel edge,  $43 + 10 \log(P)$  dB on all frequencies between 5 megahertz and X megahertz from the channel edge, and  $55 + 10 \log(P)$  dB on all frequencies more than X megahertz from the channel edge, where X is the greater of 6 megahertz or the actual emission bandwidth as defined in paragraph (m)(6) of this section. In addition, the attenuation factor shall not be less that  $43 + 10 \log(P)$  dB on all frequencies between 2490.5 MHz and 2496 MHz and  $55 + 10 \log(P)$  dB at or below 2490.5 MHz. Mobile Satellite Service licensees operating on frequencies below 2495 MHz may also submit a documented interference complaint against BRS licensees operating on channel BRS Channel 1 on the same terms and conditions as adjacent channel BRS or EBS licensees.

The center of the spectrum analyzer was set to block edge frequency  
Waltek Services (Shenzhen) Co.,Ltd.  
<http://www.waltek.com.cn>

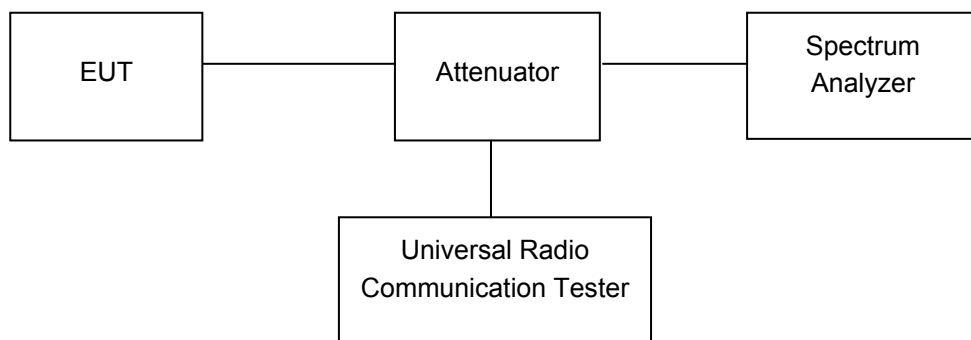

### 13.3 Test Result

PASS

#### LTE Band

Please refer to the Appendix Band 13 LTE Band Edge.

## 14 FREQUENCY STABILITY

Test Requirement:	FCC Part 2.1055, 27.5(h),27.54
Test Method:	TIA/EIA-603-D:2010 KDB971168 D01 v03
Test Mode:	TX transmitting

### 14.1 EUT Operation

Operating Environment :	
Temperature:	22.9 °C
Humidity:	52.0 % RH
Atmospheric Pressure:	101.3kPa

### 14.2 Test Procedure

Frequency Stability vs. Temperature: The equipment under test was connected to an external DC power supply and the RF output was connected to communication test set via feed-through attenuators. The EUT was placed inside the temperature chamber. The DC leads and RF output cable exited the chamber through an opening made for the purpose.

After the temperature stabilized for approximately 20 minutes, the frequency output was recorded from the communication test set.

Frequency Stability vs. Voltage: For hand carried, battery powered equipment; reduce primary supply voltage to the battery operating end point which shall be specified by the manufacturer.

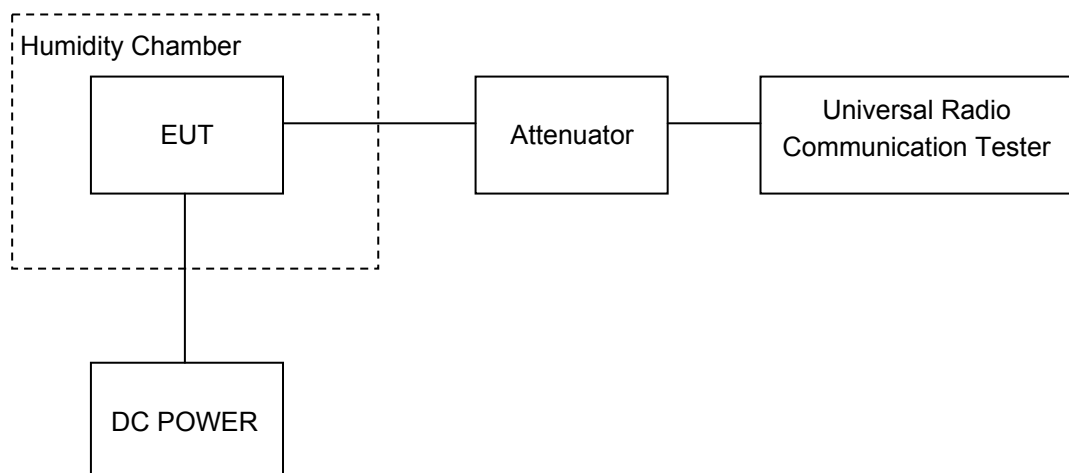

### 14.3 Test Result

#### LTE Band 13

Test Frequency: 782.0MHz QPSK 10MHz				
Temperature (°C)	Power Supply (VDC)	Frequency Error (Hz)	Frequency Error (ppm)	Limit (ppm)
50	3.8	13	0.0155	2.5
40		14	0.0167	2.5
30		0	0.0000	2.5
20		5	0.0060	2.5
10		-1	-0.0012	2.5
0		7	0.0084	2.5
-10		5	0.0060	2.5
-20		9	0.0108	2.5
-30		11	0.0131	2.5
20		3.3	8	0.0096
20	4.2	-1	-0.0012	2.5

Test Frequency: 782.0MHz 16QAM 10MHz				
Temperature (°C)	Power Supply (VDC)	Frequency Error (Hz)	Frequency Error (ppm)	Limit (ppm)
50	3.8	12	0.0143	2.5
40		8	0.0096	2.5
30		11	0.0131	2.5
20		6	0.0072	2.5
10		3	0.0036	2.5
0		1	0.0012	2.5
-10		14	0.0167	2.5
-20		4	0.0048	2.5
-30		2	0.0024	2.5
20		3.3	5	0.0060
20	4.2	0	0.0000	2.5

## **15 RF Exposure**

Remark: refer to SAR test report: WTS19S02008883-1W.

