



TEST REPORT

Test Report No. : UL-RPT-RP-12851020-516-FCC

Applicant : Pirelli Tire LLC
Model No. : PSN-09S
FCC ID : 2ANX7CPSN1
Technology : Bluetooth – Low Energy
Test Standard(s) : FCC Parts 15.209(a) & 15.247

For details of applied tests refer to test result summary

1. This test report shall not be reproduced in full or partial, without the written approval of UL International Germany GmbH.
2. The results in this report apply only to the sample tested.
3. The test results in this report are traceable to the national or international standards.
4. Test Report Version 1.0
5. Result of the tested sample: **PASS**

Prepared by: Abdoufataou Salifou
Title: Laboratory Engineer
Date: 12 September 2019

Approved by: Ajit, Phadtare
Title: Lead Test Engineer
Date: 12 September 2019



Deutsche
Akkreditierungsstelle
D-PL-19381-02-00

This laboratory is accredited by DAkkS.
The tests reported herein have been performed in
accordance with its' terms of accreditation.

This page has been left intentionally blank.

Table of Contents

1. Customer Information.....	4
1.1.Applicant Information	4
1.2.Manufacturer Information	4
2. Summary of Testing.....	5
2.1. General Information	5
Applied Standards	5
Location	5
Date information	5
2.2. Summary of Test Results	6
2.3. Methods and Procedures	6
2.4. Deviations from the Test Specification	6
3. Equipment Under Test (EUT)	7
3.1. Identification of Equipment Under Test (EUT)	7
3.2. Description of EUT	8
3.3. Modifications Incorporated in the EUT	8
3.4. Additional Information Related to Testing	9
3.5. Support Equipment	9
A. Support Equipment (In-house)	9
B. Support Equipment (Manufacturer supplied)	9
4. Operation and Monitoring of the EUT during Testing	10
4.1. Operating Modes	10
4.2. Configuration and Peripherals	10
5. Measurements, Examinations and Derived Results	11
5.1. General Comments	11
5.2. Test Results	12
5.2.1. Transmitter Minimum 6 dB Bandwidth	12
5.2.2. Transmitter Duty Cycle	14
5.2.3. Transmitter Maximum Peak Output Power	16
5.2.4. Transmitter Radiated Emissions	20
5.2.5. Transmitter Band Edge Radiated Emissions	33
6. Measurement Uncertainty	37
7. Used equipment.....	38
8. Report Revision History	39

1. Customer Information

1.1.Applicant Information

Company Name:	Pirelli Tire LLC
Company Address:	546 Fifth Avenue 8th Floor, 10036 New York, NY, USA
Company Phone No.:	+1-212-497-8800
Company E-Mail:	-/-
Contact Person:	Camila Amaral Surcan
Contact E-Mail Address:	camila.surcan@pirelli.com
Contact Phone No.:	+1-212-497-8800

1.2.Manufacturer Information

Company Name:	Pirelli Tyre S.p.A.
Company Address:	Viale Piero e Alberto Pirelli 25, 20126 Milano, Italy
Company Phone No.:	+39 02 64421
Company E-Mail:	-/-
Contact Person:	Regini Edoardo
Contact E-Mail Address:	edoardo.regini@pirelli.com
Contact Phone No.:	+39 02 6442 59862

2. Summary of Testing

2.1. General Information

Applied Standards

Specification Reference:	47CFR15.247
Specification Title:	Code of Federal Regulations Volume 47 (Telecommunications): Part 15 Subpart C (Intentional Radiators) - Section 15.247
Specification Reference:	47CFR15.209
Specification Title:	Code of Federal Regulations Volume 47 (Telecommunications): Part 15 Subpart C (Intentional Radiators) – Sections 15.209
Test Firm Registration:	399704

Location

Location of Testing:	UL International Germany GmbH Hedelfinger Str. 61 70327 Stuttgart Germany
-----------------------------	--

Date information

Order Date:	06 May 2019
EUT arrived:	09 July 2019
Test Dates:	09 July 2019 & 16 July 2019
EUT returned:	-/-

2.2. Summary of Test Results

Clause	Measurement	Complied	Did not comply	Not performed	Not applicable
Part 15.207	Transmitter AC Conducted Emissions ⁽¹⁾	<input type="checkbox"/>	<input type="checkbox"/>	<input type="checkbox"/>	<input checked="" type="checkbox"/>
Part 15.247(a)(2)	Transmitter Minimum 6 dB Bandwidth	<input checked="" type="checkbox"/>	<input type="checkbox"/>	<input type="checkbox"/>	<input type="checkbox"/>
Part 15.35(c)	Transmitter Duty Cycle	<input checked="" type="checkbox"/>	<input type="checkbox"/>	<input type="checkbox"/>	<input type="checkbox"/>
Part 15.247(e)	Transmitter Power Spectral Density ⁽²⁾	<input type="checkbox"/>	<input type="checkbox"/>	<input checked="" type="checkbox"/>	<input type="checkbox"/>
Part 15.247(b)(3)	Transmitter Maximum Peak Output Power	<input checked="" type="checkbox"/>	<input type="checkbox"/>	<input type="checkbox"/>	<input type="checkbox"/>
Part 15.247(d)/15.209(a)	Transmitter Radiated Emissions	<input checked="" type="checkbox"/>	<input type="checkbox"/>	<input type="checkbox"/>	<input type="checkbox"/>
Part 15.247(d)/15.209(a)	Transmitter Band Edge Radiated Emissions	<input checked="" type="checkbox"/>	<input type="checkbox"/>	<input type="checkbox"/>	<input type="checkbox"/>

Notes:

1. Not Applicable as EUT operates using a non rechargeable battery power.
2. In accordance with KDB 558074 D01 section 8.4 referencing ANSI C63.10:2013, subclause 11.10.1, PSD is not required if the maximum conducted output power is less than the PSD limit of 8 dBm / 3 kHz. The PSD level is therefore deemed to be equal to the measured total output power.

2.3. Methods and Procedures

Reference:	ANSI C63.10-2013
Title:	American National Standard of Procedures for Compliance Testing of Unlicensed Wireless Devices
Reference:	KDB 558074 D01 DTS Meas Guidance v05r02, April 2, 2019
Title:	Guidance for Compliance Measurements on Digital Transmission System, Frequency Hopping Spread Spectrum System, and Hybrid System Devices Operating Under Section 15.247 of the FCC Rules
Reference:	KDB 414788 D01 Radiated Test Site v01r01
Title:	TEST SITES FOR RADIATED EMISSION MEASUREMENTS

2.4. Deviations from the Test Specification

For the measurements contained within this test report, there were no deviations from, additions to, or exclusions from the test specification identified above.

3. Equipment Under Test (EUT)

3.1. Identification of Equipment Under Test (EUT)

Brand Name:	Pirelli
Model Name or Number:	PSN-09S
Test Sample Serial Number:	ID:RF-T1 (Radiated sample with Chip Antenna: Channel 2402 MHz)
Hardware Version Number:	1.2
Software Version Number:	Test Mode 1.x (x depending on application level)
FCC ID:	2ANX7CPSN1

Brand Name:	Pirelli
Model Name or Number:	PSN-09S
Test Sample Serial Number:	ID:RF-T2 (Radiated sample with Chip Antenna: Channel 2442 MHz)
Hardware Version Number:	1.2
Software Version Number:	Test Mode 1.x (x depending on application level)
FCC ID:	2ANX7CPSN1

Brand Name:	Pirelli
Model Name or Number:	PSN-09S
Test Sample Serial Number:	ID:RF-T3 (Radiated sample with Chip Antenna: Channel 2480 MHz)
Hardware Version Number:	1.2
Software Version Number:	Test Mode 1.x (x depending on application level)
FCC ID:	2ANX7CPSN1

Brand Name:	Pirelli
Model Name or Number:	PSN-09S
Test Sample Serial Number:	ID:RF-C1 (Conducted sample with RF port : Channel 2402 MHz)
Hardware Version Number:	1.2
Software Version Number:	Test Mode 1.x (x depending on application level)
FCC ID:	2ANX7CPSN1

Brand Name:	Pirelli
Model Name or Number:	PSN-09S
Test Sample Serial Number:	ID:RF-C2 (Conducted sample with RF port : Channel 2442 MHz)
Hardware Version Number:	1.2
Software Version Number:	Test Mode 1.x (x depending on application level)
FCC ID:	2ANX7CPSN1

Brand Name:	Pirelli
Model Name or Number:	PSN-09S
Test Sample Serial Number:	ID:RF-C3 (Conducted sample with RF port : Channel 2480 MHz)
Hardware Version Number:	1.2
Software Version Number:	Test Mode 1.x (x depending on application level)
FCC ID:	2ANX7CPSN1

3.2. Description of EUT

The equipment under test was a Tyre Pressure Monitoring Sensor (TPMS) supporting Bluetooth Low Energy 5.0 interface.

3.3. Modifications Incorporated in the EUT

No modifications were applied to the EUT during testing.

3.4. Additional Information Related to Testing

Technology Tested:	Bluetooth Low Energy (Digital Transmission System)		
Type of Unit:	Transceiver		
Channel Spacing:	2 MHz		
Modulation:	GFSK		
Data Rate:	1 Mbps		
Power Supply Requirement(s):	Nominal 3 V DC	CR2032: Lithium Dioxide Manganese Battery	
Maximum measured Conducted Output Power:	-0.3 dBm		
Maximum Antenna Gain:	-10.0 dBi		
Antenna Type:	Ceramic Chip Antenna		
Antenna Details:	Johansson Technology P/N 2450AT18A100E-AEC		
Transmit Frequency Range:	2402 MHz to 2480 MHz		
Transmit Channels Tested:	Channel ID	RF Channel	Channel Frequency (MHz)
	Bottom	0	2402
	Middle	19	2442
	Top	39	2480

3.5. Support Equipment

The following support equipment was used to exercise the EUT during testing:

A. Support Equipment (In-house)

Item	Description	Brand Name	Model Name or Number	Serial Number
1	Laboratory Power Supply	Conrad Electronic	PS-2403D	Not stated

B. Support Equipment (Manufacturer supplied)

Item	Description	Brand Name	Details	Serial Number
1	W.FL-SMA (Female) RF Cable	Not stated	Maximum Attenuation 1 dB @2.4 GHz Cable Length : 11.4 cm	Not stated
2	CR2032 Battery Cells (6 Pieces)	maxell	CR2032HRS 3 V DC	Not stated

4. Operation and Monitoring of the EUT during Testing

4.1. Operating Modes

The EUT was tested in the following operating mode(s):

- Bluetooth Low Energy : Transmitting at maximum power with modulation, maximum possible data length available and Pseudorandom Bit Sequence 9.

4.2. Configuration and Peripherals

The EUT was tested in the following configuration(s):

- The customer supplied a document containing the setup instructions "PSN 1.2 RED-FCC Certification.pptx".
- The Radiated EUT's were powered using CR2032HRS Battery Cells supplied by the customer. In order to ensure that radiated tests are carried out with maximum output power & sufficient battery levels, battery cells were changed after regular time intervals.
- The Conducted EUT's were powered using 3 V DC using Laboratory DC Power Supply.
- All Conducted measurements were carried out by connecting RF Module's output to W.FL-SMA (Female) RF Cable supplied by the customer. The RF cable's attenuation (maximum 1.0 dB@2.4GHz) was added to a reference level offset to each of the conducted plots.

- The EUT's were pre-configured by customer into test mode with following test channels:

Radiated EUT Sample	Conducted EUT Sample	Test Channel
ID:RF-T1	ID:RF-C1	2402 MHz
ID:RF-T2	ID:RF-C2	2442 MHz
ID:RF-T3	ID:RF-C3	2480 MHz

- All of the supplied EUT's were transmitting modulated carrier continuously with 100 % duty cycle, therefore no duty cycle correction was required.
- The conducted samples were used for duty cycle, bandwidth, output power measurements.
- The radiated sample were used for radiated spurious emission, radiated band edge measurements.
- All radiated tests have been performed adding potting layer between PCB and Battery, and adding plastic cap on the top of the PCB simulating the final configuration.
- Before starting final radiated spurious emission measurements "worst case verification" with the EUT in Standing-position & Laying-position was performed by Lab.
- The EUT in Standing-position was found to be the worst case therefore this report includes relevant results.
- Radiated spurious emissions were performed with the EUT positioned on the turn table and rotating 360 degrees while the antenna height varies from 1 to 4 m over the measurement frequency range.
- EMC32 V10.1.0 Software was used for the Radiated spurious emission measurements.

5. Measurements, Examinations and Derived Results

5.1. General Comments

Measurement uncertainties are evaluated in accordance with current best practice. Our reported expanded uncertainties are based on standard uncertainties, which are multiplied by an appropriate coverage factor to provide a statistical confidence level of approximately 95%. Please refer to Section 6 *Measurement Uncertainty* for details.

In accordance with DAkkS requirements all the measurement equipment is on a calibration schedule. All equipment was within the calibration period on the date of testing.

5.2. Test Results

5.2.1. Transmitter Minimum 6 dB Bandwidth

Test Summary:

Test Engineer:	Abdoufataou Salifou	Test Date:	09 July 2019
Test Sample Serial Number:	ID:RF-C1, ID:RF-C2 and ID:RF-C3		
Test Site Identification	SR 9		

FCC Reference:	Part 15.247(a)(2)
Test Method Used:	FCC KDB 558074 Section 8.2 referring ANSI C63.10:2013 Section 11.8.1 Option 1

Environmental Conditions:

Temperature (°C):	22.9
Relative Humidity (%):	32

Notes:

- 6 dB DTS bandwidth tests were performed using a spectrum analyser in accordance with FCC KDB 558074 Section 8.2 referring ANSI C63.10 Section 11.8 (11.8.1 Option 1 measurement procedure). The spectrum analyser resolution bandwidth was set to 100 kHz and video bandwidth 300 kHz. A peak detector was used, sweep time was set to auto and the trace mode was Max Hold. The DTS bandwidth was measured at 6 dB down from the peak of the signal.
- The RF port on the EUT was connected to the spectrum analyser using suitable attenuation and RF cable. The measured values takes into consideration the external attenuation correction factors. The RF cable attenuation (maximum 0.4 dB@2.4GHz) from the EUT to Analyzer including the 10 dB attenuation at the Spectrum Analyzer input and 1.0 dB for the W.FL cable attenuation was added as a reference level offset (11.4 dB) to each of the conducted plots.

Test Setup:

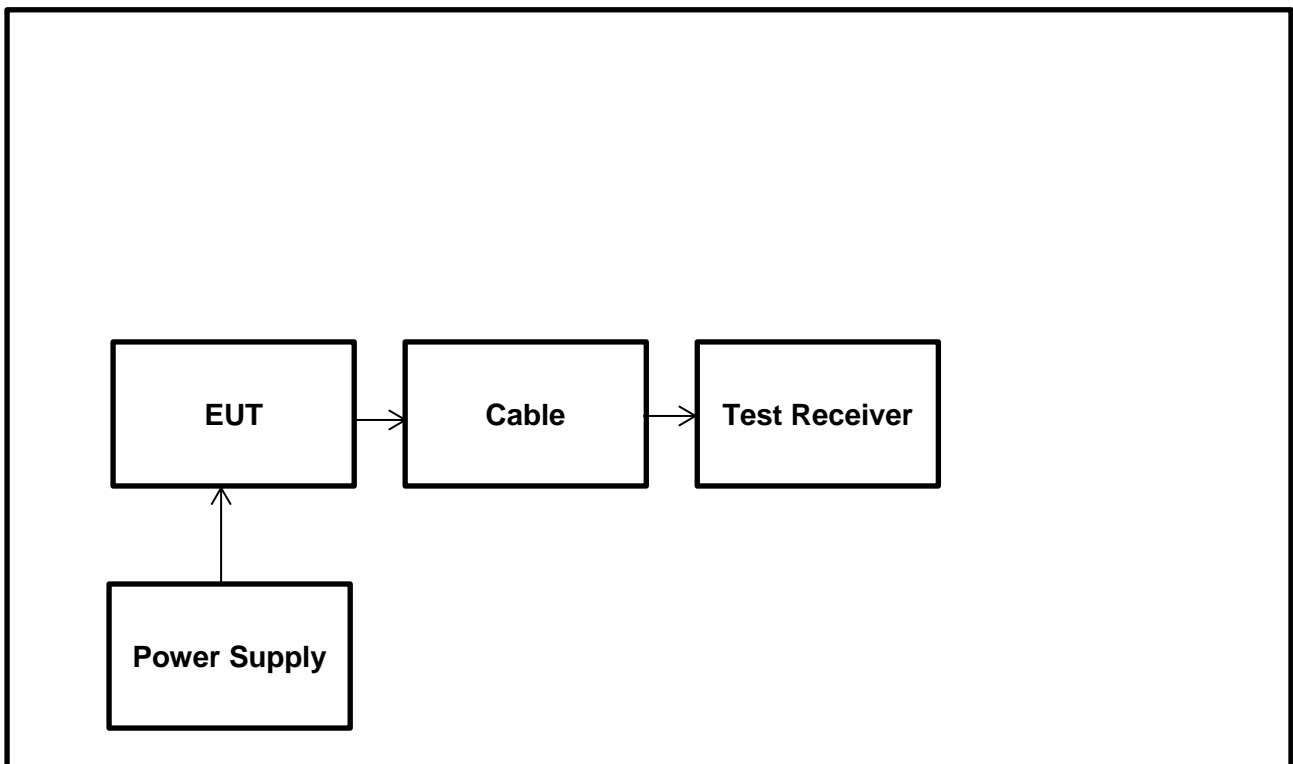

Transmitter Minimum 6 dB Bandwidth (continued)

Results:

Channel	6 dB Bandwidth (kHz)	Limit (kHz)	Margin (kHz)	Result
Bottom	725.696	≥500	225.696	Complied
Middle	742.383	≥500	242.383	Complied
Top	759.633	≥500	259.633	Complied

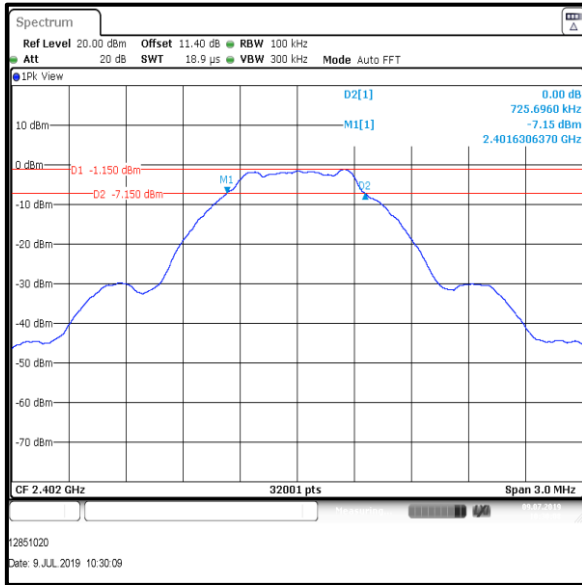

Bottom Channel

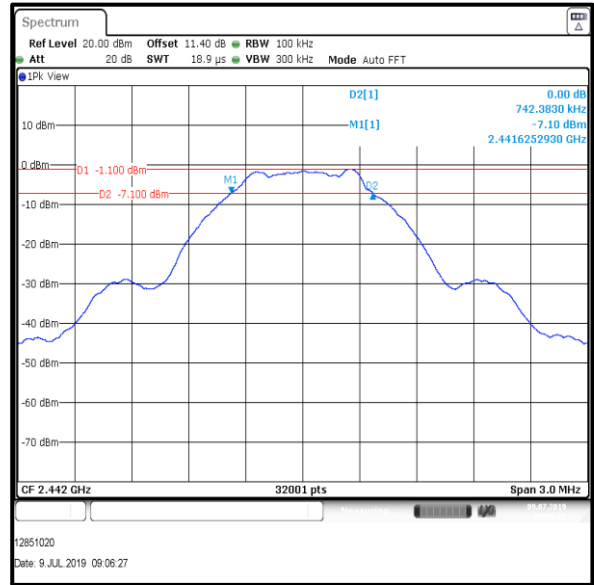

Middle Channel

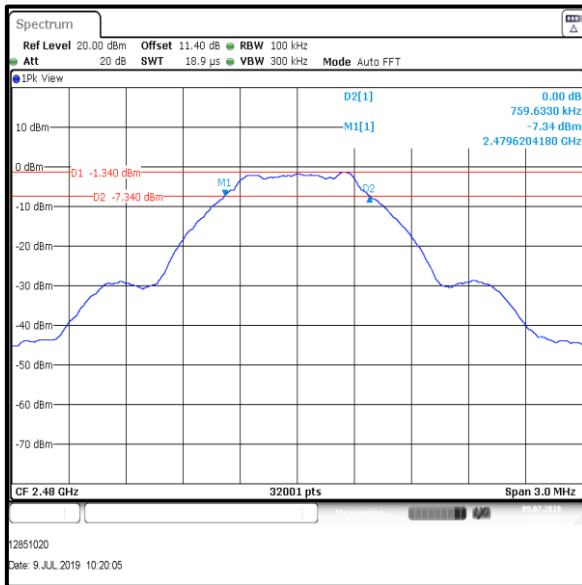

Top Channel

Result: Pass

5.2.2. Transmitter Duty Cycle

Test Summary:

Test Engineer:	Abdoufataou Salifou	Test Date:	09 July 2019
Test Sample Serial Number:	ID:RF-C1, ID:RF-C2 and ID:RF-C3		
Test Site Identification	SR 9		

FCC Reference:	Part 15.35(c)
Test Method Used:	FCC KDB 558074 Section 6.0

Environmental Conditions:

Temperature (°C):	23.0
Relative Humidity (%):	29

Note:

The transmitter duty cycle was measured using a spectrum analyser in the time domain and calculated by using the following calculation:

$$10 \log (1 / (\text{On Time} / [\text{Period or } 100 \text{ ms whichever is the lesser}])).$$

$$\text{BLE duty cycle: } 10 \log (1 / (100 \text{ ms} / 100\text{ms})) = 0.0 \text{ dB}$$

Test Setup:

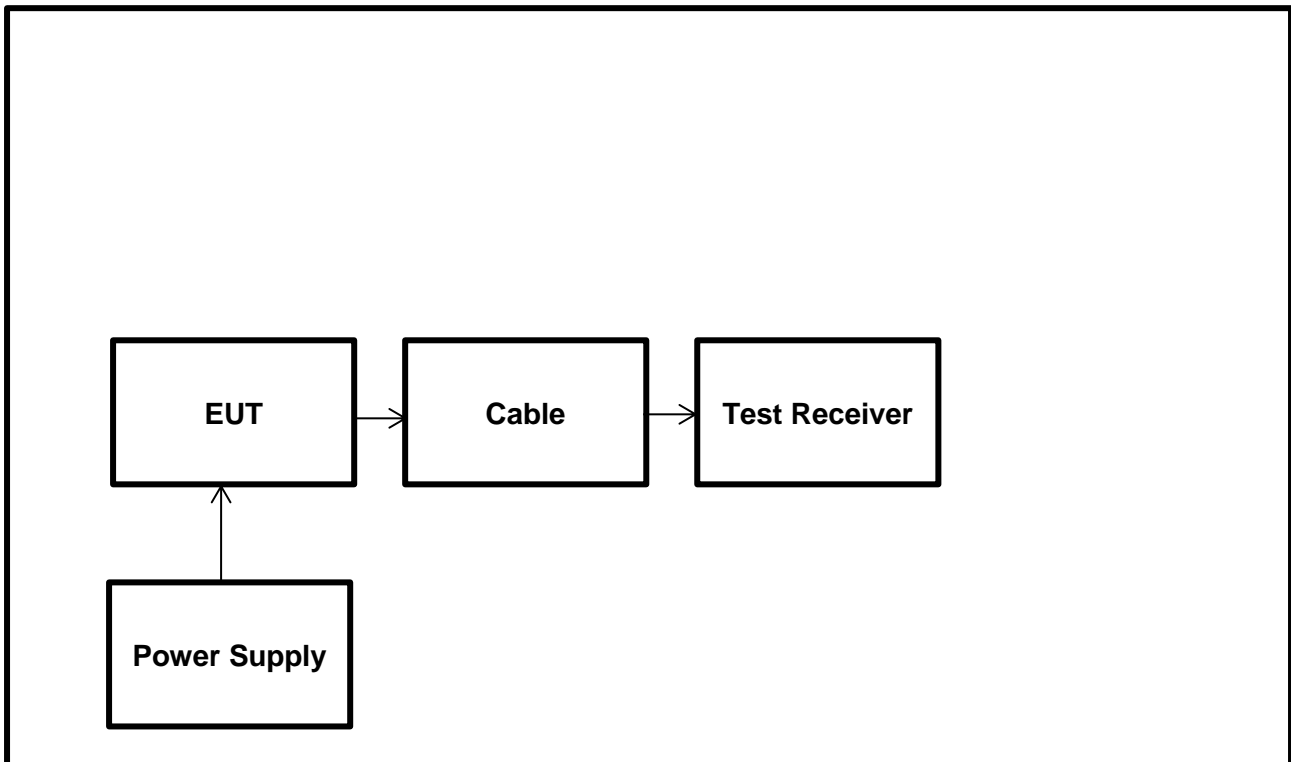

Transmitter Duty Cycle (continued)

Results:

Pulse Duration (s)	Period (s)	Duty Cycle Correction (dB)
1	1	0.0

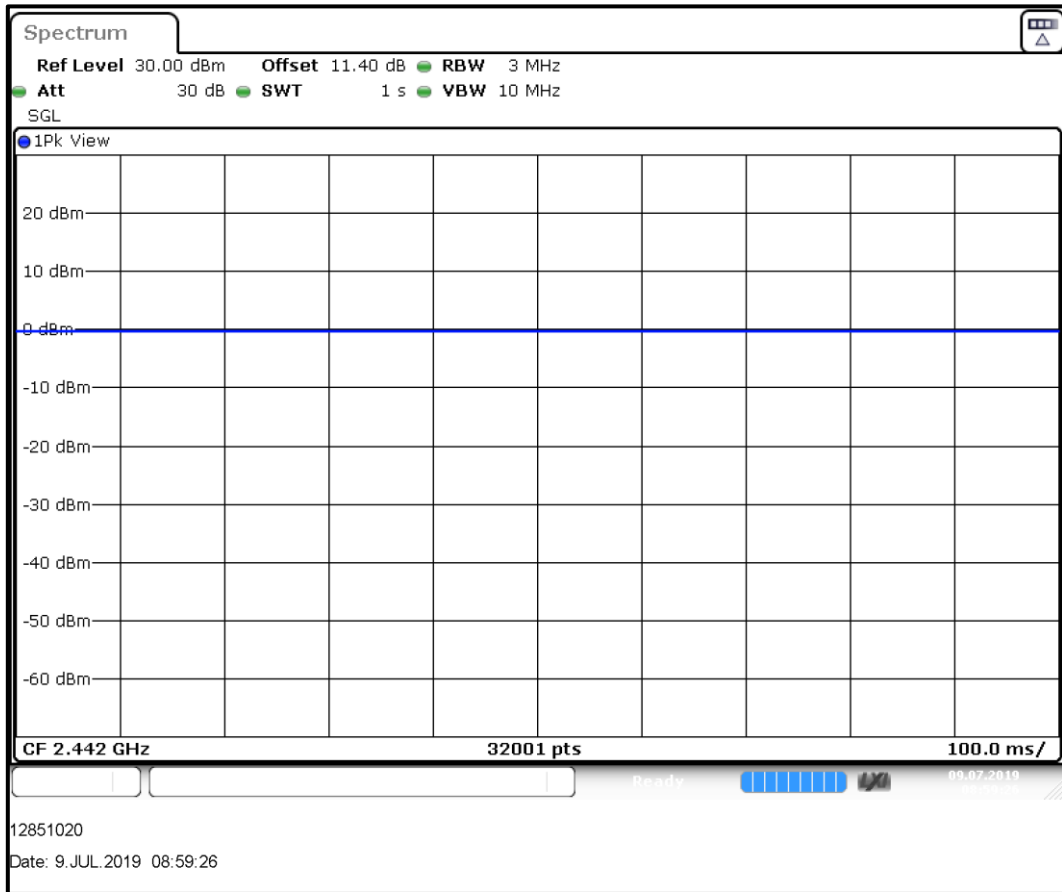

5.2.3. Transmitter Maximum Peak Output Power

Test Summary:

Test Engineer:	Abdoufataou Salifou	Test Date:	09 July 2019
Test Sample Serial Number:	ID:RF-C1, ID:RF-C2 and ID:RF-C3		
Test Site Identification	SR 9		

FCC Reference:	Part 15.247(b)(3)
Test Method Used:	FCC KDB 558074 Section 8.3.1.1 referring ANSI C63.10 Section 11.9.1.1

Environmental Conditions:

Temperature (°C):	22.7
Relative Humidity (%):	32

Notes:

1. Conducted power tests were performed using a spectrum analyser in accordance with FCC KDB 558074 Section 8.3.1.1 with the $RBW \geq DTS \text{ bandwidth}$ referring ANSI C63.10 Section 11.9.1.1.
2. The signal analyser resolution bandwidth was set to 3 MHz and video bandwidth of 10 MHz. A peak detector was used, sweep time was set to auto and trace mode was Max Hold. The span was set to 10 MHz. A marker was placed at the peak of the signal and the results recorded in the table below.
3. The RF port on the EUT was connected to the spectrum analyser using suitable attenuation and RF cable. The measured values takes into consideration the external attenuation correction factors. The RF cable attenuation (maximum 0.4 dB@2.4GHz) from the EUT to Analyzer including the 10 dB attenuation at the Spectrum Analyzer input and 1.0 dB for the W.FL cable attenuation was added as a reference level offset (11.4 dB) to each of the conducted plots.
4. The declared antenna gain was added to conducted power to obtain the EIRP.

Transmitter Maximum Peak Output Power (continued)

Test setup:

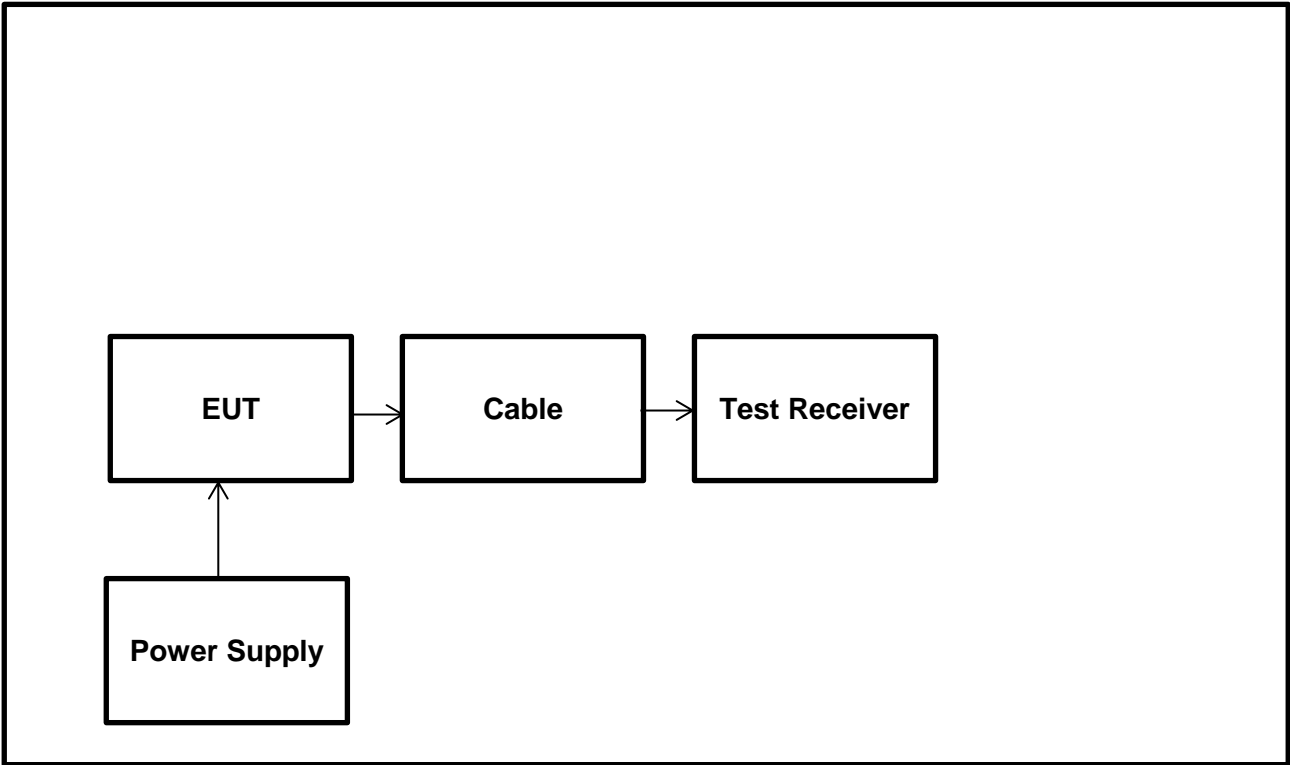

Transmitter Maximum Peak Output Power (continued)

Results:

Channel	Conducted Peak Power (dBm)	Conducted Peak Power Limit (dBm)	Margin (dB)	Result
Bottom	-0.35	30.0	30.35	Complied
Middle	-0.29	30.0	30.29	Complied
Top	-0.57	30.0	30.57	Complied

Channel	Conducted Peak Power (dBm)	Declared Antenna Gain (dBi)	EIRP (dBm)	De Facto EIRP Limit (dBm)	Margin (dB)	Result
Bottom	-0.35	-10.0	-10.35	36.0	46.35	Complied
Middle	-0.29	-10.0	-10.29	36.0	46.29	Complied
Top	-0.57	-10.0	-10.57	36.0	46.57	Complied

Transmitter Maximum Peak Output Power (continued)

Plots:

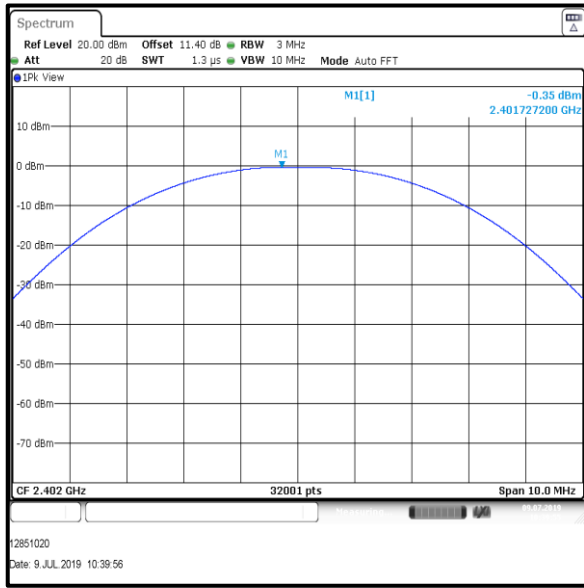

Bottom Channel

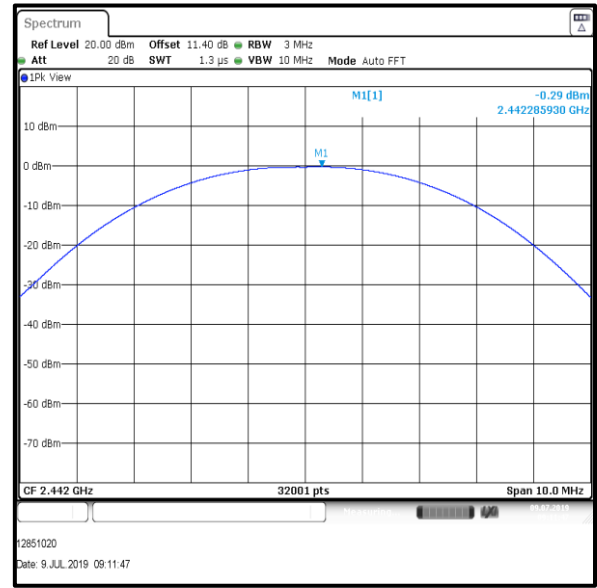

Middle Channel

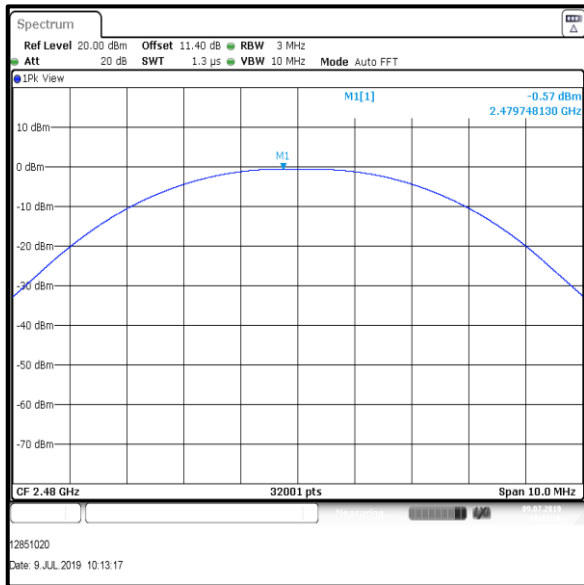

Top Channel

Result: **Pass**

5.2.4. Transmitter Radiated Emissions

Test Summary:

Test Engineer:	Krume Ivanov	Test Date:	09 July 2019
Test Sample Serial Number:	ID:RF-T1, ID:RF-T2 and ID:RF-T3		
Test Site Identification	SR 1/2		

FCC Reference:	Parts 15.247(d) & 15.209(a)
Test Method Used:	FCC KDB 558074 Sections 8.5 & 8.6 referring ANSI C63.10 Sections 11.11 and 11.12 ANSI C63.10:2013 Sections 6.3 and 6.4
Frequency Range	9 kHz to 30 MHz

Environmental Conditions:

Temperature (°C):	23
Relative Humidity (%):	28

Notes:

1. In accordance with FCC KDB 414788, an alternative test site may be used for the measurement below 30 MHz (The OATS / SAC comparison data is available upon request). Therefore the result from the semi-anechoic chamber tests is shown in this section of the test report.
2. The final measured value, for the given emission, in the table below incorporates the calibrated antenna factor and cable loss.
3. The preliminary scans showed similar emission levels below 30 MHz, for each channel of operation. Therefore final radiated emissions measurements were performed with the EUT set to the Bottom Channel only.
4. All emissions shown on the pre-scan plots were investigated and found to be ambient or > 20 dB below the appropriate limit.
5. Measurements below 30 MHz were performed in a semi-anechoic chamber (Asset Number K0001) at a distance of 3 metres. The EUT was placed at a height of 80 cm above the reference ground plane in the centre of the chamber turntable.
6. Pre-scans were performed and markers placed on the highest measured levels. The test receiver resolution bandwidth was set to 10 kHz and video bandwidth 30 kHz. A peak detector was used, sweep time was set to auto and trace mode was Max Hold.
7. Final measurements were performed on the marker frequencies and the results entered into the table below. The test receiver resolution bandwidth was set to 9 kHz, using a CISPR quasi-peak detector and span big enough to see the whole emission.

Transmitter Radiated Emissions (continued)

Test Setup:

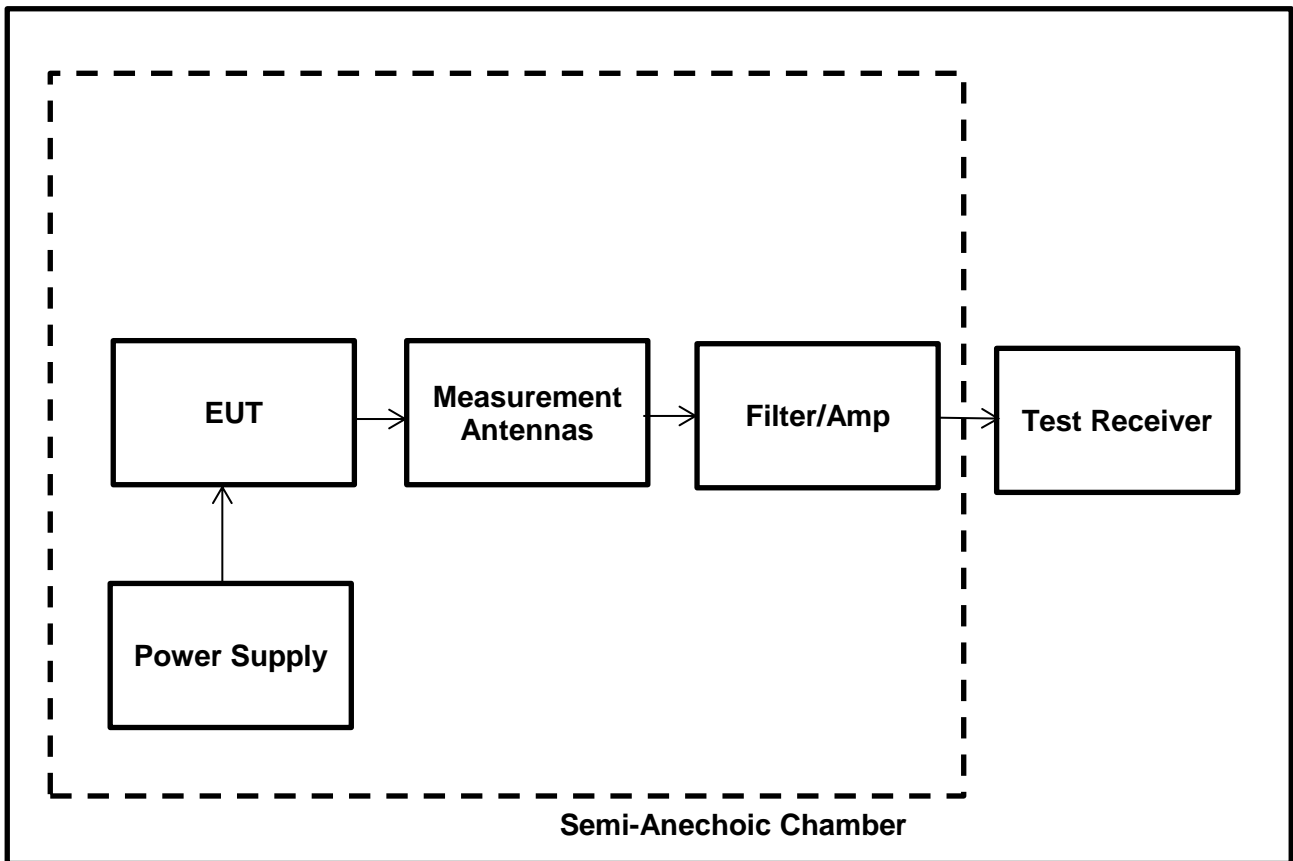

Transmitter Radiated Emissions (continued)

Results: Bluetooth Low Energy / Peak Method / Bottom Channel

Frequency (MHz)	Antenna Polarization	Peak Level (dB μ V/m)	Peak Limit (dB μ V/m)	Margin (dB)	Result
No spurious emissions were detected					

Plot: 9 kHz – 30 MHz: Bluetooth Low Energy / Bottom Channel

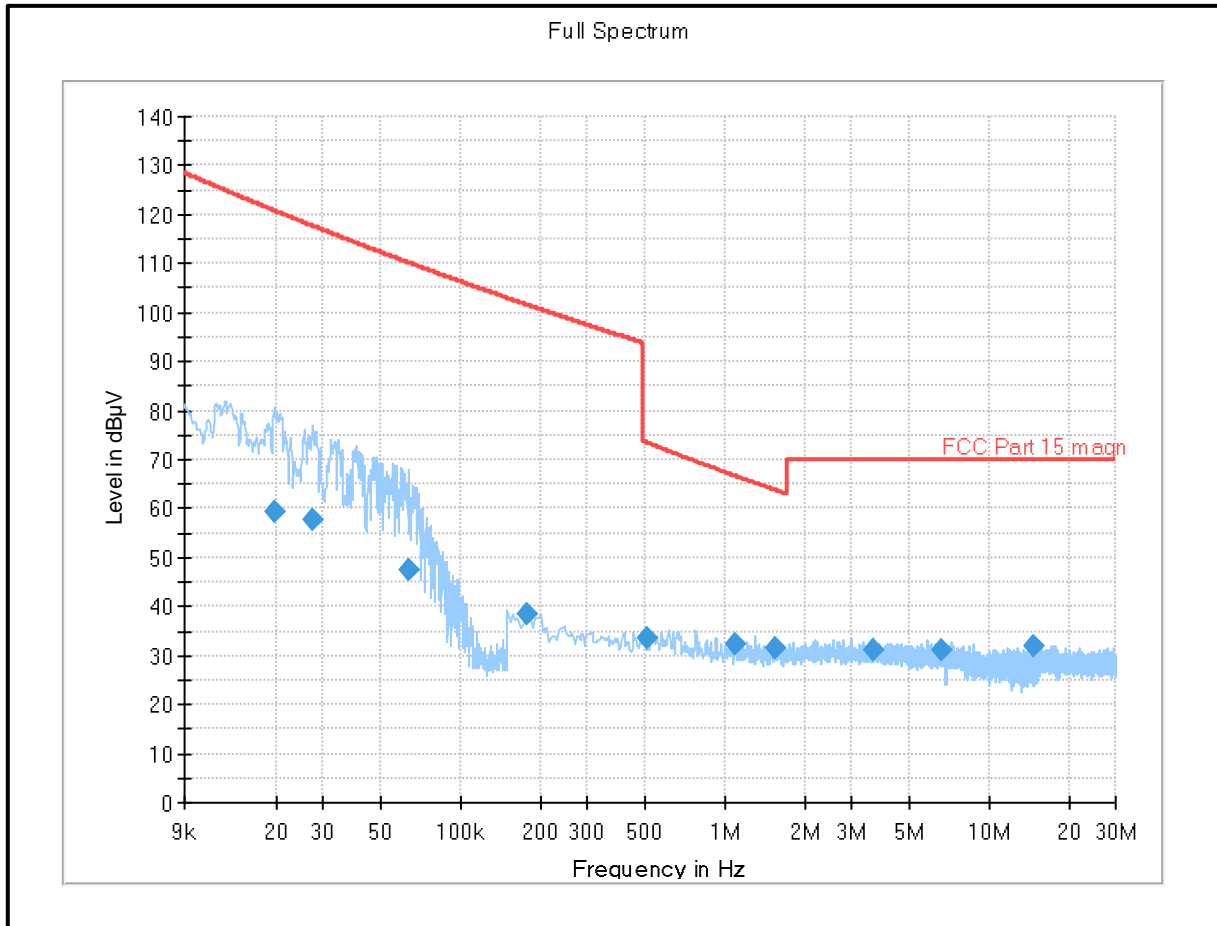

Result: Pass

Transmitter Radiated Emissions (continued)

Test Summary:

Test Engineer:	Krume Ivanov	Test Date:	09 July 2019
Test Sample Serial Number:	ID:RF-T1, ID:RF-T2 and ID:RF-T3		
Test Site Identification	SR 1/2		

FCC Reference:	Parts 15.247(d) & 15.209(a)
Test Method Used:	FCC KDB 558074 Sections 8.5 & 8.6 referring ANSI C63.10 Sections 11.11 and 11.12 ANSI C63.10:2013 Sections 6.3 and 6.5
Frequency Range	30 MHz to 1000 MHz

Environmental Conditions:

Temperature (°C):	23
Relative Humidity (%):	40

Notes:

1. The final measured value, for the given emission, in the table below incorporates the calibrated antenna factor and cable loss.
2. The preliminary scans showed similar emission levels below 1 GHz, for each channel of operation. Therefore final radiated emissions measurements were performed with the EUT set to the Bottom Channel only.
3. All emissions shown on the pre-scan plots were investigated and found to be ambient or > 20 dB below the appropriate limit.
4. Measurements below 1 GHz were performed in a semi-anechoic chamber (Asset Number K0001) at a distance of 3 m. The EUT was placed at a height of 80 cm above the reference ground plane in the centre of the chamber turntable. Maximum emission levels were determined by height searching the measurement antenna over the range 1 m to 4 m.
5. Pre-scans were performed and markers placed on the highest measured levels. The test receiver resolution bandwidth was set to 100 kHz and video bandwidth 300 kHz. A peak detector was used, sweep time was set to auto and trace mode was Max Hold.
6. Final measurements were performed on the marker frequencies and the results entered into the table below. The test receiver resolution bandwidth was set to 120 kHz, using a CISPR quasi-peak detector and span big enough to see the whole emission.
- 7.

Transmitter Radiated Emissions (continued)

Test Setup:

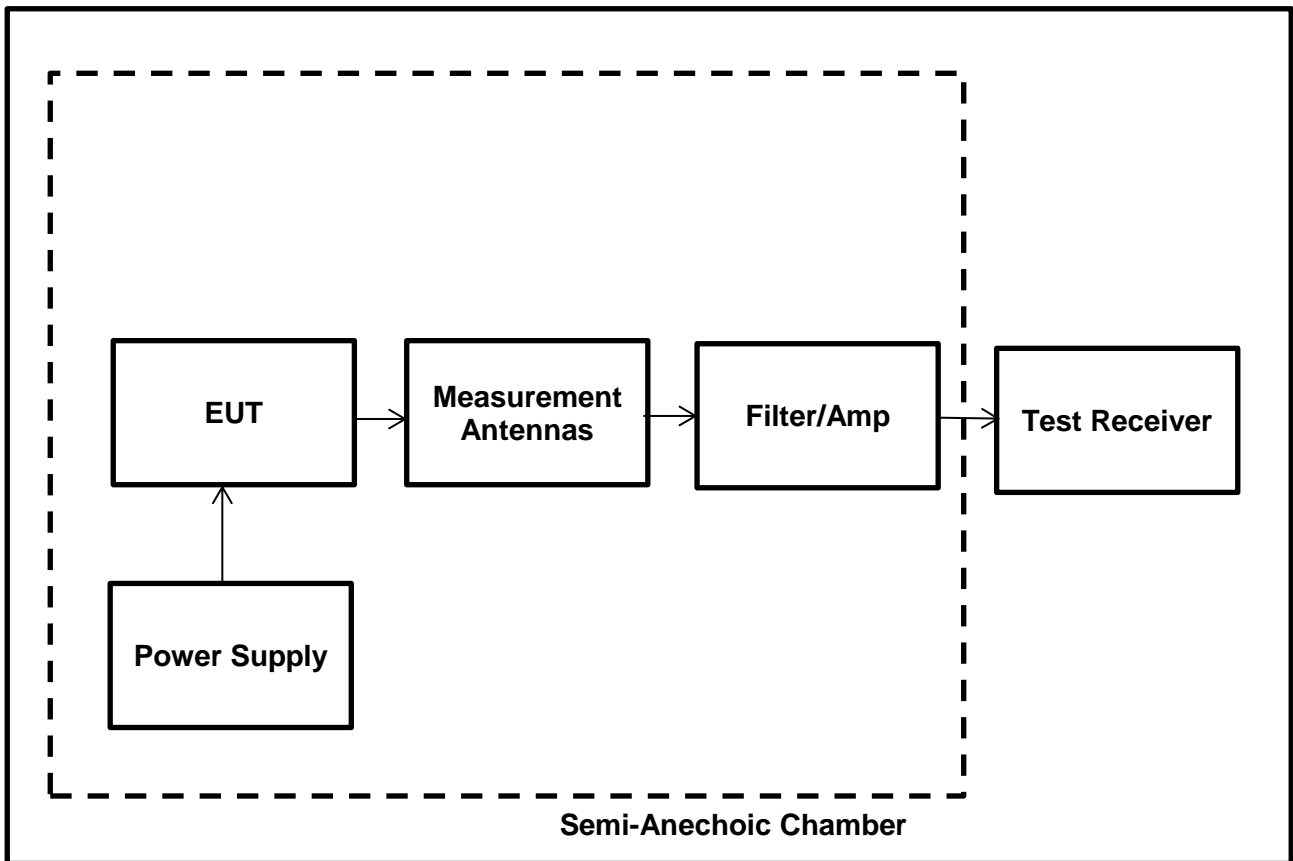

Transmitter Radiated Emissions (continued)

Results: Bluetooth Low Energy / Peak Method / Bottom Channel

Frequency (MHz)	Antenna Polarization	Peak Level (dB μ V/m)	Peak Limit (dB μ V/m)	Margin (dB)	Result
No spurious emissions were detected					

Plot: 30 MHz-1 GHz: Bluetooth Low Energy / Bottom Channel

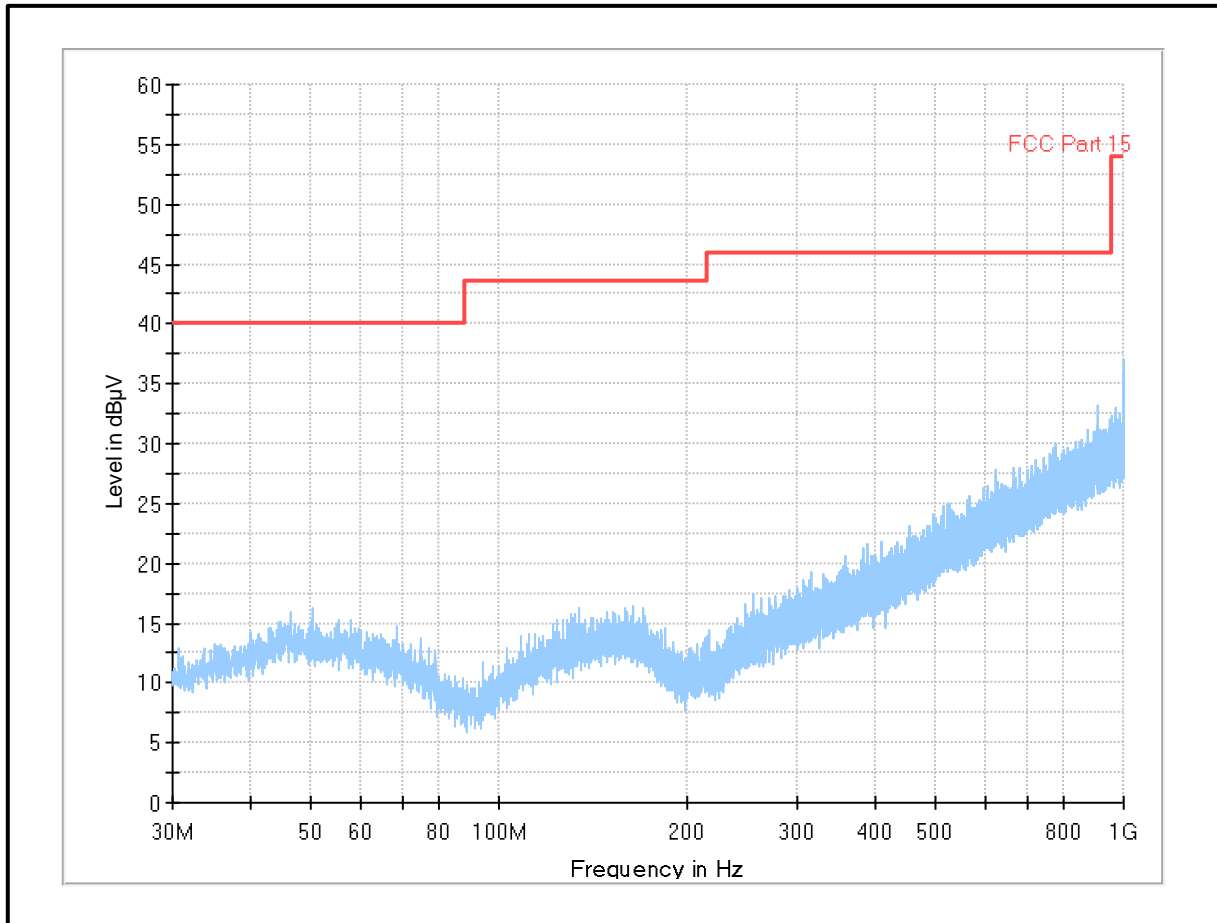

Result: Pass

Transmitter Radiated Emissions (continued)

Test Summary:

Test Engineer:	Krume Ivanov	Test Date:	09 July 2019 & 16 July 2019
Test Sample Serial Number:	ID:RF-T1, ID:RF-T2 and ID:RF-T3		
Test Site Identification	SR 1/2		

FCC Reference:	Parts 15.247(d) & 15.209(a)
Test Method Used:	FCC KDB 558074 Sections 8.5 & 8.6 referring ANSI C63.10 Sections 11.11 and 11.12 ANSI C63.10:2013 Sections 6.3 and 6.6
Frequency Range	1 GHz to 25 GHz

Environmental Conditions:

Temperature (°C):	23
Relative Humidity (%):	28

Notes:

1. The final measured value, for the given emission, in the table below incorporates the calibrated antenna factor and cable loss.
2. No spurious emissions were detected above the noise floor of the measuring receiver therefore the highest peak and average noise floor readings of the measuring receiver were recorded as shown in the tables below.
3. All other emissions shown on the pre-scan plot were investigated and found to be ambient or >20 dB below the appropriate limit or below the measurement system noise floor.
4. The emission shown approximately at 2.4-2.4835 GHz on the 1 GHz to 18 GHz plot is the EUT fundamental.
5. Pre-scans above 1 GHz were performed in a fully anechoic chamber at a distance of 3 m. The EUT was placed at a height of 1.5 m above the test chamber floor in the centre of the chamber turntable. All measurement antennas were placed at a fixed height of 1.5 metres above the test chamber floor, in line with the EUT. Final measurements above 1 GHz were performed in a fully anechoic chamber at a distance of 3 m. The EUT was placed at a height of 1.5 m above the reference ground plane in the centre of the chamber turntable. Maximum emission levels were determined by height searching the measurement antenna over the range 1 m to 4 m.
6. Pre-scans were performed and a marker placed on the highest measured level of the appropriate plot. The test receiver resolution bandwidth was set to 1 MHz and video bandwidth 3 MHz. The sweep time was set to auto.
7. *In accordance with ANSI C63.10 Section 6.6.4.3 (Note 1), if the peak measured value complies with the average limit, it is unnecessary to perform an average measurement.
8. The preliminary scans showed similar emission levels above 18 GHz, for each channel of operation. Therefore final radiated emissions measurements were performed with the EUT set to the bottom channel only.
9. The EUT was transmitting continuously with 100 % duty cycle, therefore no duty cycle correction was required.

Transmitter Radiated Emissions (continued)

Test Setup:

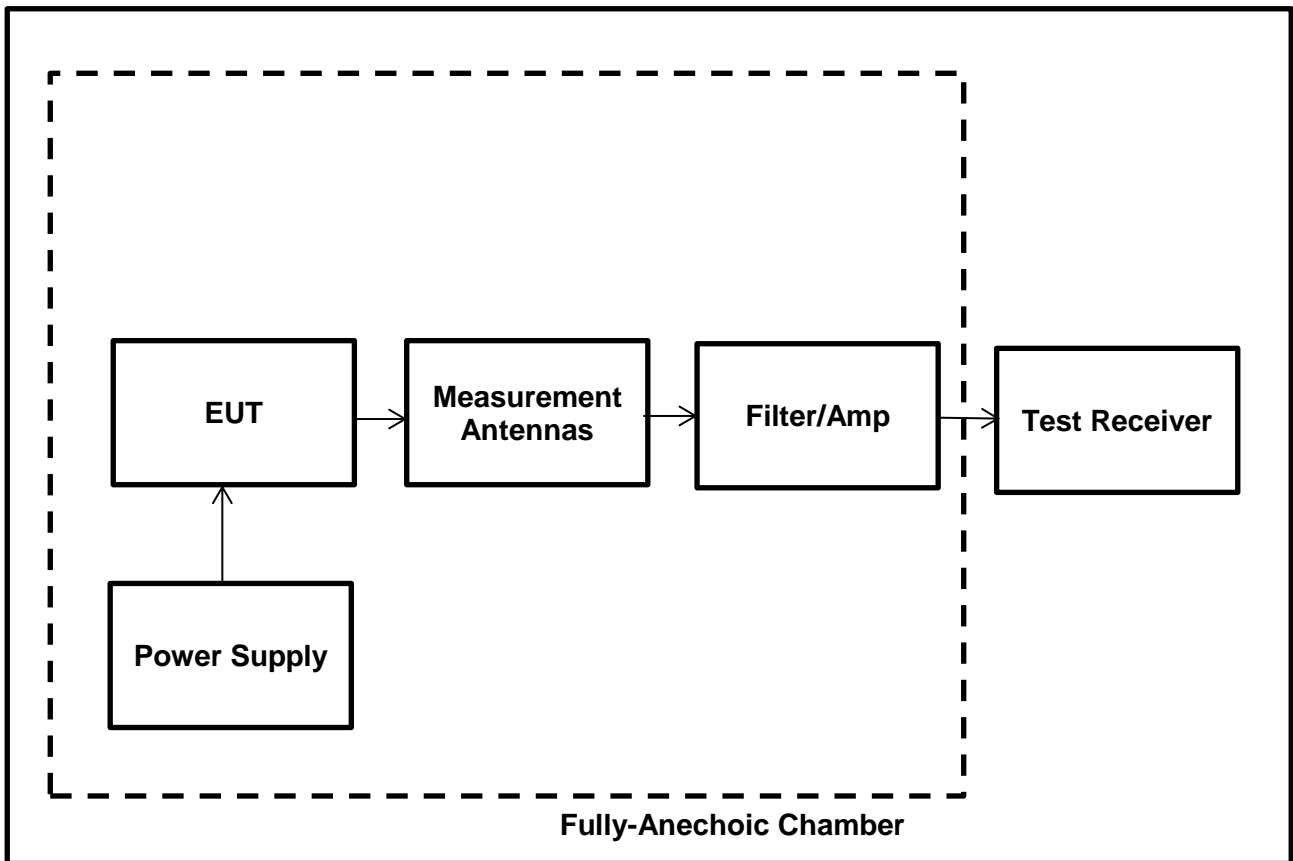

Transmitter Radiated Emissions (continued)

Results: Bluetooth Low Energy / Peak Method / Bottom Channel

Frequency (MHz)	Antenna Polarization	Peak Level (dB μ V/m)	Peak Limit (dB μ V/m)	Margin (dB)	Result
No spurious emissions were detected					

Results: Bluetooth Low Energy / Peak Method / Middle Channel

Frequency (MHz)	Antenna Polarization	Peak Level (dB μ V/m)	Peak Limit (dB μ V/m)	Margin (dB)	Result
No spurious emissions were detected					

Results: Bluetooth Low Energy / Peak Method / Top Channel

Frequency (MHz)	Antenna Polarization	Peak Level (dB μ V/m)	Peak Limit (dB μ V/m)	Margin (dB)	Result
No spurious emissions were detected					

Result: **Pass**

Transmitter Radiated Emissions (continued)

Plot:1 GHz-18 GHz: Bluetooth Low Energy / Bottom Channel

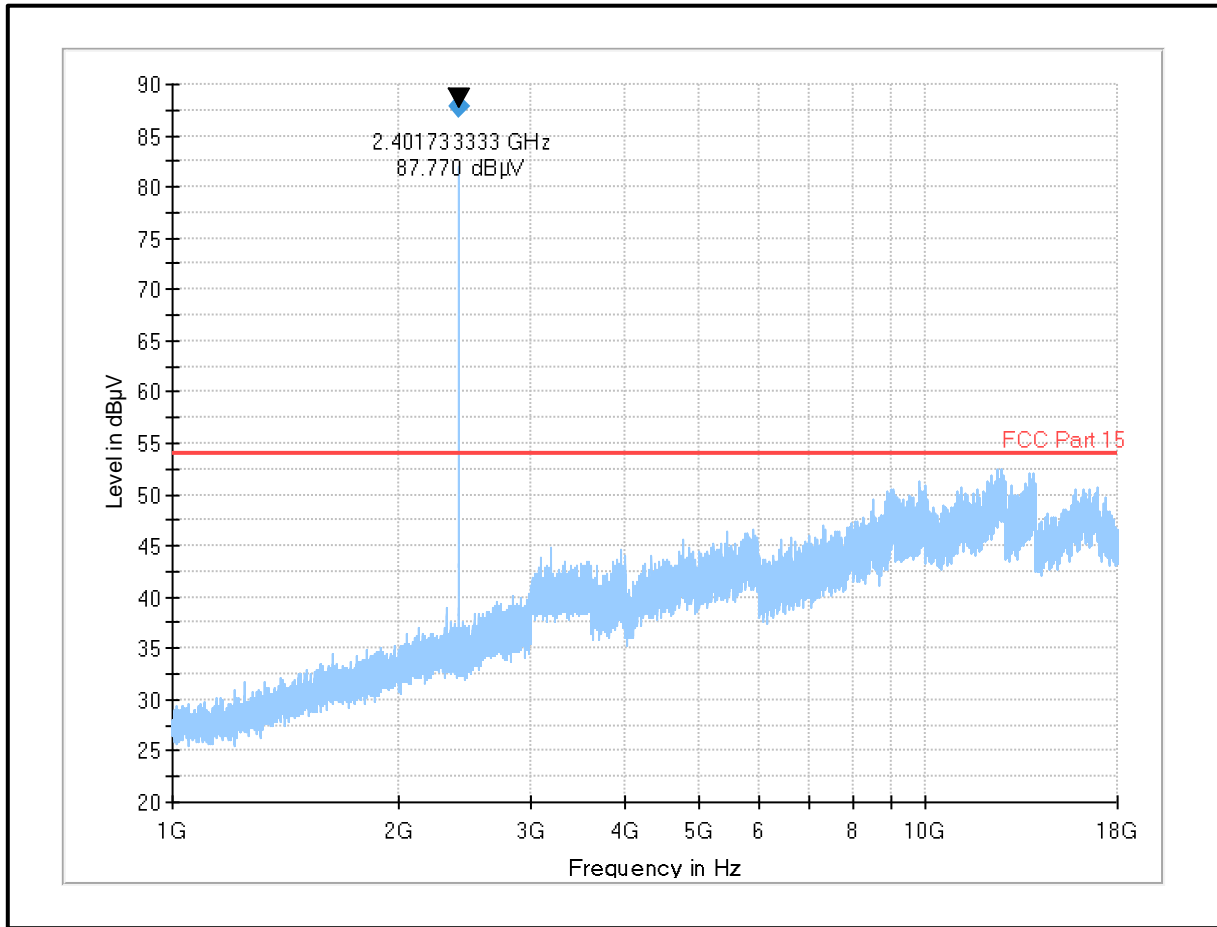

Transmitter Radiated Emissions (continued)

Plot:1 GHz-18 GHz: Bluetooth Low Energy / Middle Channel

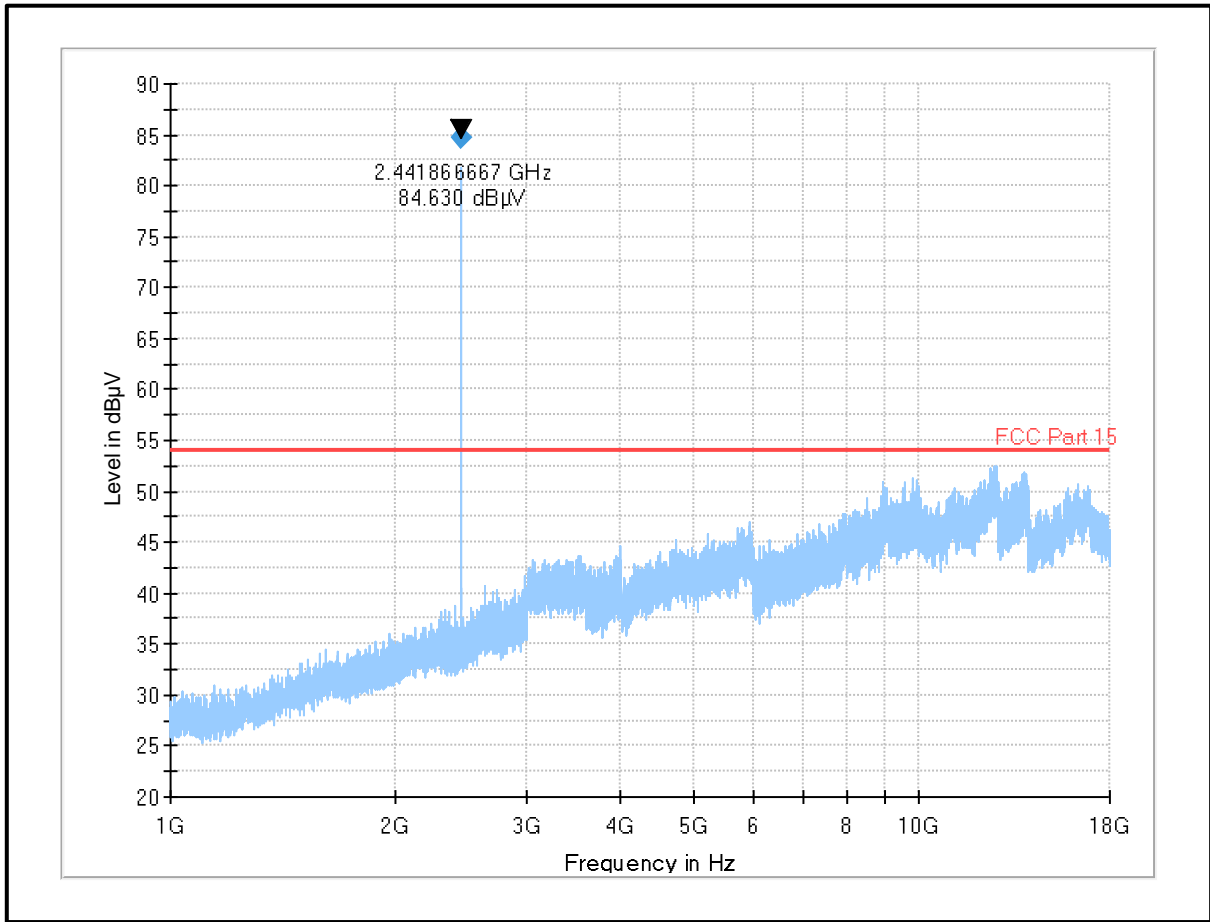

Transmitter Radiated Emissions (continued)

Plot:1 GHz-18 GHz: Bluetooth Low Energy / Top Channel

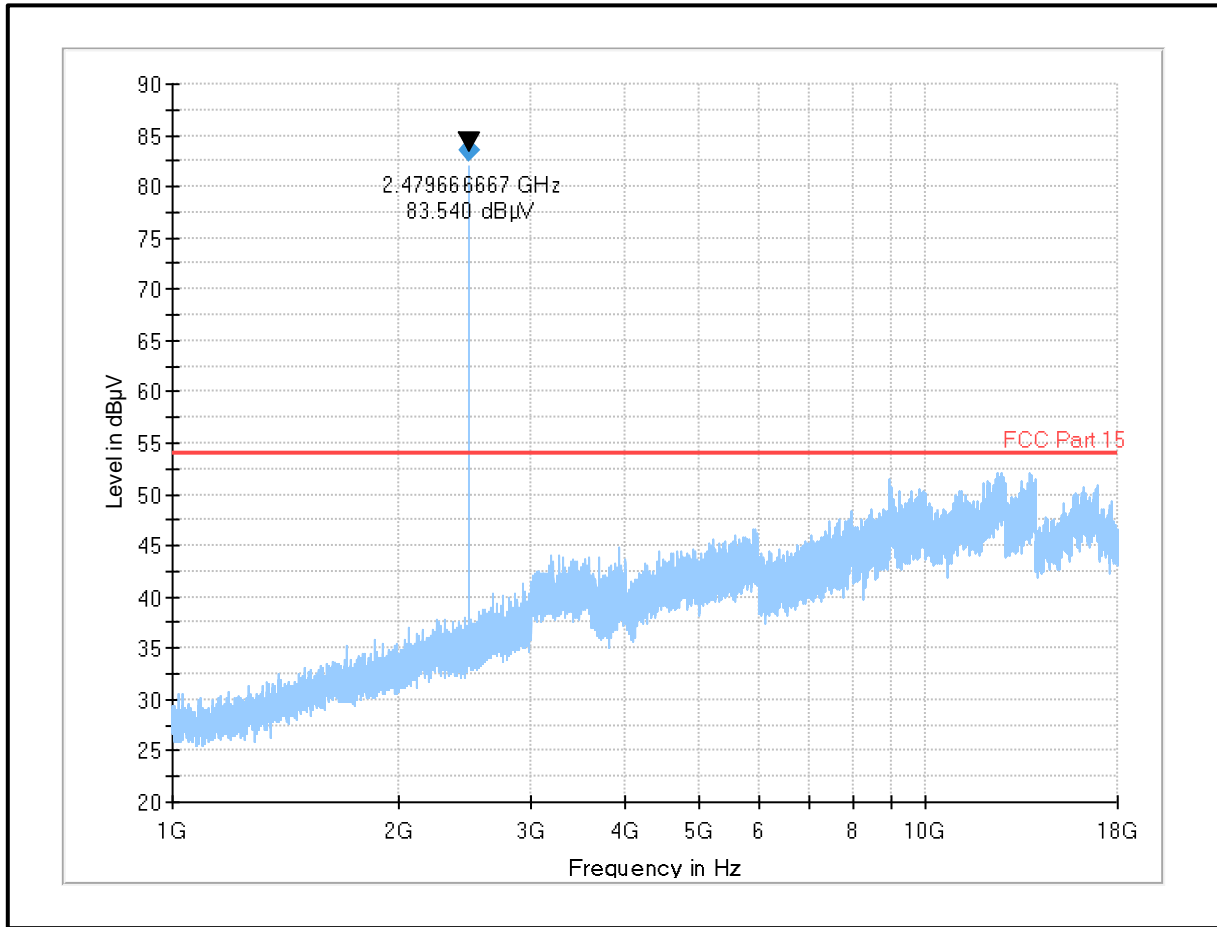

Transmitter Radiated Emissions (continued)

Plot:18 GHz-25 GHz: Bluetooth Low Energy / Bottom Channel

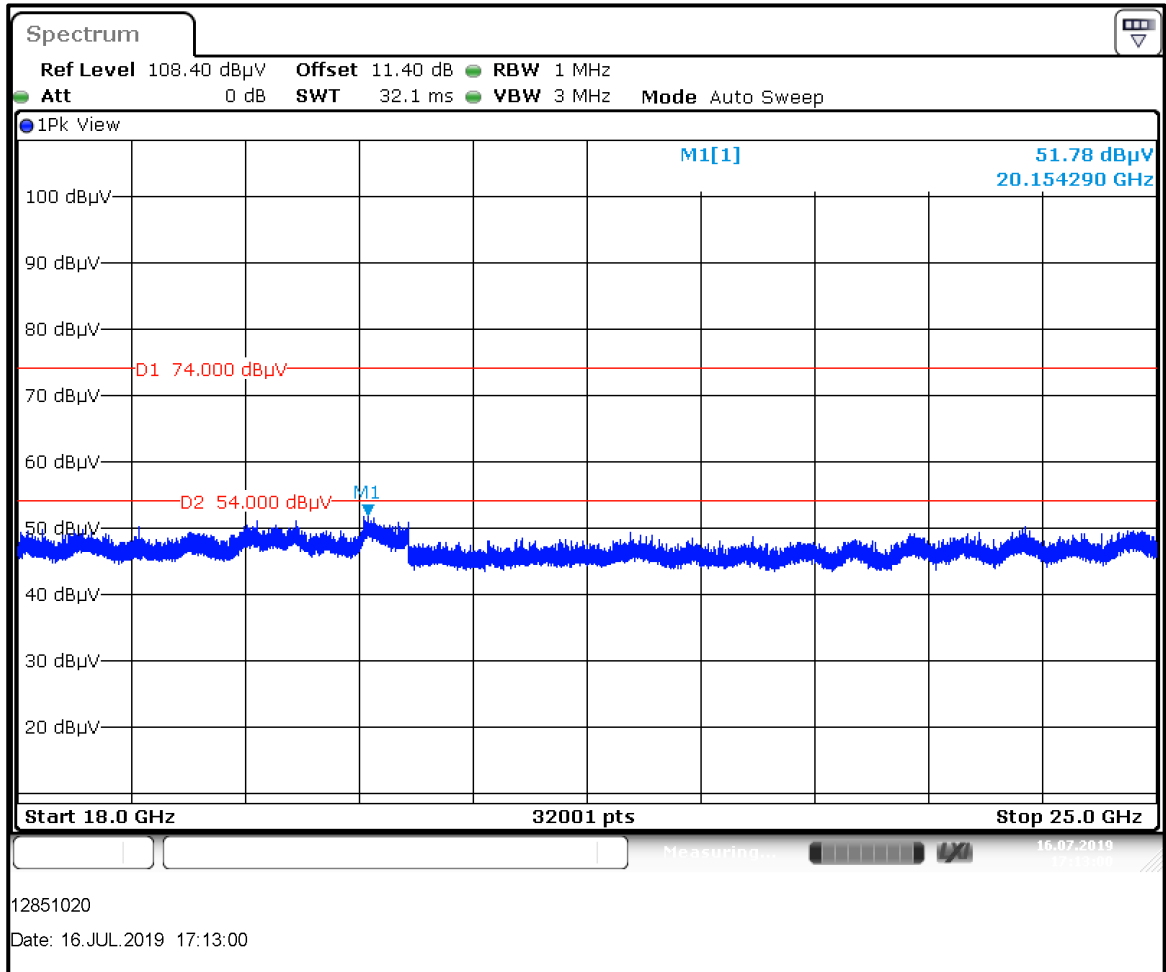

5.2.5. Transmitter Band Edge Radiated Emissions

Test Summary:

Test Engineer:	Krume Ivanov	Test Date:	09 July 2019
Test Sample Serial Number:	ID:RF-T1, ID:RF-T2 and ID:RF-T3		
Test Site Identification	SR 1/2		

FCC Reference:	Part 15.247(d)
Test Method Used:	FCC KDB 558074 Sections 8.7 referring ANSI C63.10:2013 Section 6.10.4, 6.10.5 & Section 11.11, 11.2 ,11.13

Environmental Conditions:

Temperature (°C):	25
Relative Humidity (%):	31

Notes:

1. The final measured value, for the given emission, in the table below incorporates the calibrated antenna factor and cable loss.
2. As the maximum peak conducted output power was previously measured. In accordance with FCC KDB 558074 Section 8.7 lower band edge measurement was performed with a peak detector and the -20 dBc limit applied.
3. As the lower band edge falls within a non-restricted band, only peak measurements are required. The test receiver resolution bandwidth was set to 100 kHz and video bandwidth 300 kHz. A peak detector was used, sweep time was set to auto and trace mode was Max Hold. The test receiver was left to sweep for a sufficient length of time in order to maximise the carrier level and out-of-band emissions. A marker and corresponding reference level line were placed on the peak of the carrier. Marker frequencies and levels were recorded.
4. As the upper band edge falls within a restricted band both peak and average measurements were recorded by placing a marker at the edge of the band. For peak measurements the test receiver resolution bandwidth was set to 1 MHz and the video bandwidth 3 MHz. A peak detector was used, sweep time was set to auto and trace mode was Max Hold. For average measurements the test receiver resolution bandwidth was set to 1 MHz and the video bandwidth 10 Hz. A peak detector was used, sweep time was set to auto and trace mode was Max Hold. The test receiver was left to sweep for a sufficient length of time in order to maximise the carrier level and out-of-band emissions. A marker was placed on the band edge spot frequencies and a second marker placed on the highest emission level in the adjacent restricted band of operation (where a higher level emission was present). Marker frequencies and levels were recorded.
5. There is a restricted band 10 MHz below the lower band edge. The test receiver was set up as follows: the RBW set to 1 MHz, the VBW set to 3 MHz, with the sweep time set to auto couple. Peak and average measurements were performed with their respective detectors. Markers were placed on the highest point on each trace.
6. The EUT was transmitting continuously with 100 % duty cycle, therefore no duty cycle correction was required.

Transmitter Band Edge Radiated Emissions (Continued)

Test Setup:

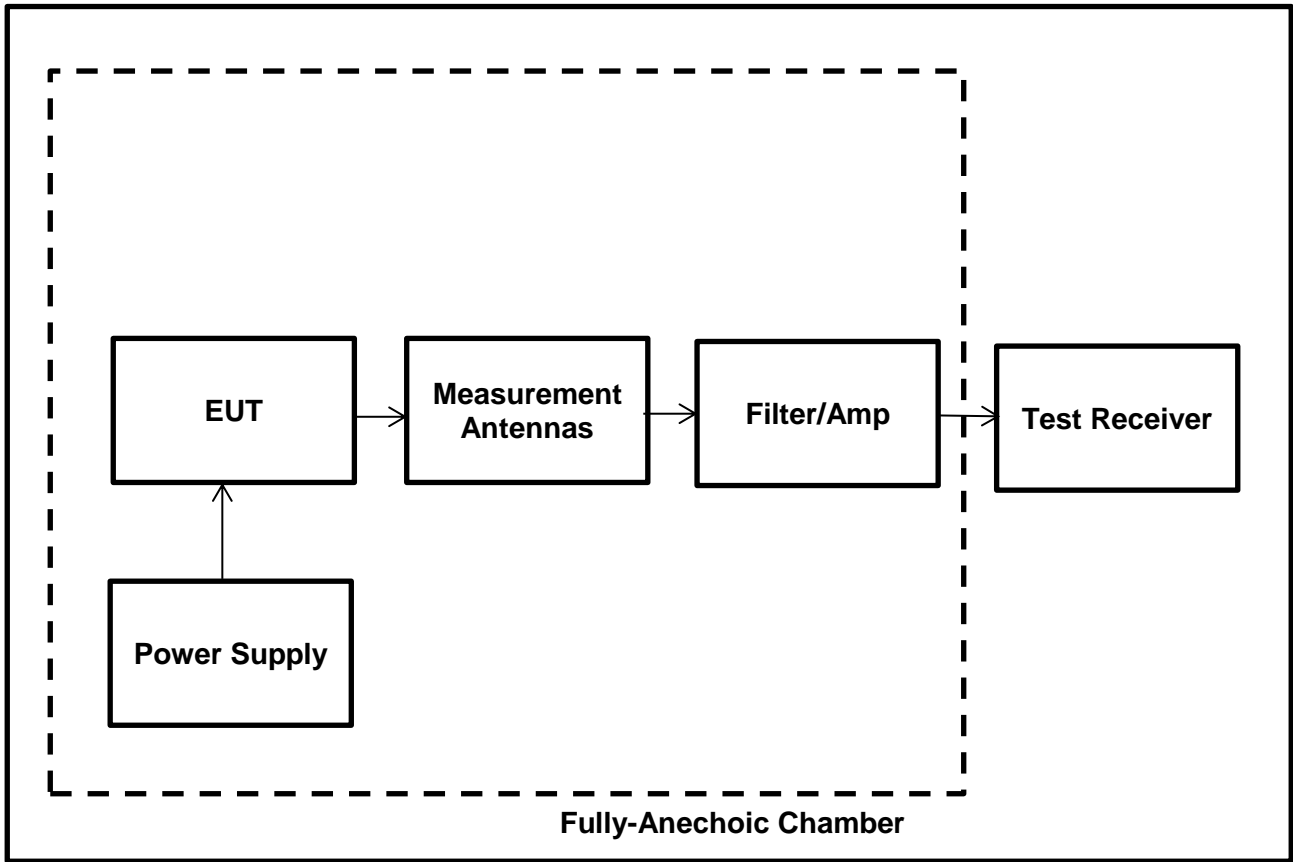

Transmitter Band Edge Radiated Emissions (Continued)

Results: Bluetooth Low Energy / Lower Band Edge / Peak

Frequency (MHz)	Peak Level (dB μ V/m)	-20 dBc Limit (dB μ V/m)	Margin (dB)	Result
2390.05	35.98	61.74	25.76	Complied
2400	36.96	61.74	24.78	Complied

Results: Bluetooth Low Energy / 2310 to 2390 MHz Restricted Band / Peak

Frequency (MHz)	Peak Level (dB μ V/m)	Peak Limit (dB μ V/m)	Margin (dB)	Result
2327.56	45.86	74.0	28.14	Complied

Results: Bluetooth Low Energy / 2310 to 2390 MHz Restricted Band / Average

Frequency (MHz)	Average Level (dB μ V/m)	Average Limit (dB μ V/m)	Margin (dB)	Result
2386.28	33.35	54.0	20.65	Complied

Results: Bluetooth Low Energy / Upper Band Edge / Peak

Frequency (MHz)	Peak Level (dB μ V/m)	Peak Limit (dB μ V/m)	Margin (dB)	Result
2483.50	46.11	74.0	27.89	Complied
2508.32	45.54	74.0	28.46	Complied

Results: Bluetooth Low Energy / Upper Band Edge / Average

Frequency (MHz)	Average Level (dB μ V/m)	Average Limit (dB μ V/m)	Margin (dB)	Result
2483.50	37.39	54.0	16.61	Complied
2483.61	36.35	54.0	17.65	Complied

Transmitter Band Edge Radiated Emissions (Continued)

Results: Bluetooth Low Energy

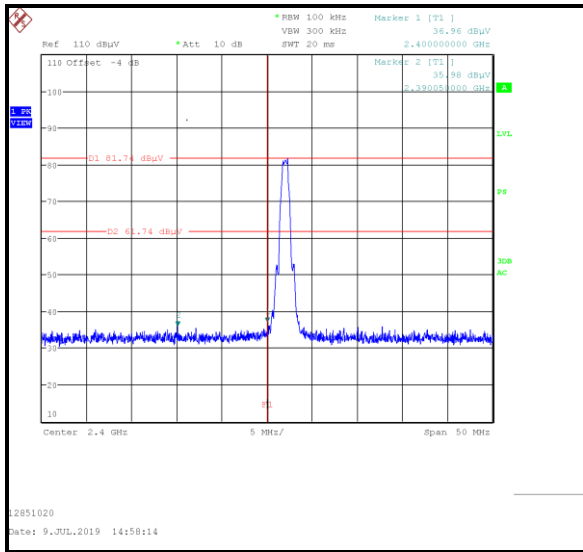

Lower Band Edge Peak Measurement

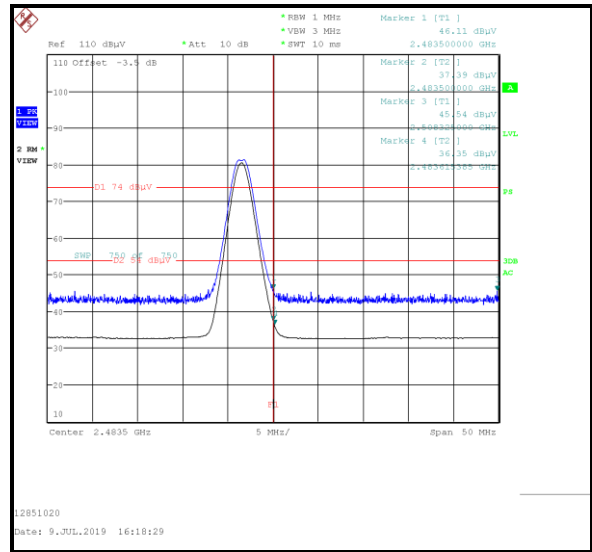

Upper Band Edge Peak and Average Measurement

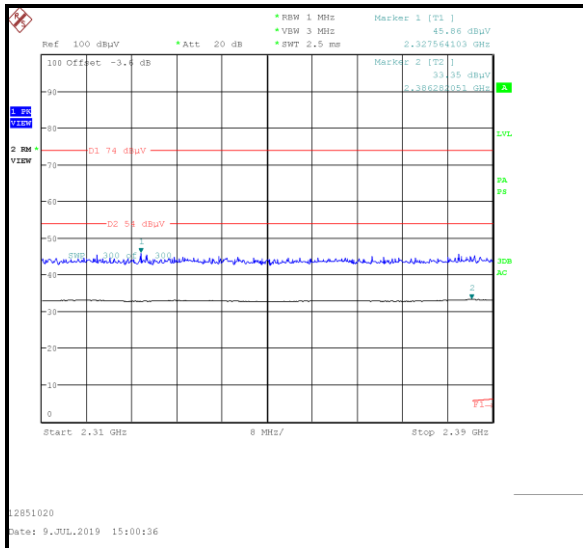

2310 MHz to 2390 MHz Restricted Band Plot

6. Measurement Uncertainty

The expression of uncertainty of a measurement result allows realistic comparison of results with reference values and limits given in specifications and standards.

The uncertainty of the result may need to be taken into account when interpreting the measurement results.

The reported expanded uncertainties below are based on a standard uncertainty multiplied by an appropriate coverage factor such that a confidence level of approximately 95% is maintained. For the purposes of this document “approximately” is interpreted as meaning “effectively” or “for most practical purposes”.

Measurement Type	Confidence Level (%)	Calculated Uncertainty
Conducted Maximum Peak Output Power	95%	±0.59 dB
Radiated Spurious Emissions	95%	±3.10 dB
Band Edge Radiated Emissions	95%	±3.10 dB
Minimum 6 dB Bandwidth	95%	±0.87 %

The methods used to calculate the above uncertainties are in line with those recommended within the various measurement specifications. Where measurement specifications do not include guidelines for the evaluation of measurement uncertainty the published guidance of the appropriate accreditation body is followed.

7. Used equipment

Test site: SR 1/2

ID	Manufacturer	Type	Model	Serial	Calibration Date	Cal. Cycle (months)
1	Rohde & Schwarz	Antenna, Loop	HFH2-Z2	831247/012	7/11/2019	36
377	BONN Elektronik	Amplifier, Low Noise Pre	BLMA 0118-1A	025294B	7/10/2019	12
423	Bonn Elektronik	Amplifier, Low Noise Pre	BLMA 1840-1A	55929	7/16/2019	12
460	Deisl	Turntable	DT 4250 S	n/a	n/a	n/a
465	Schwarzbeck	Antenna, Trilog Broadband	VULB 9168	9168-240	3/20/2019	24
496	Rohde & Schwarz	Antenna, log. - periodical	HL050	100297	2/19/2019	36
587	Maturo	antenna mast, tilting	TAM 4.0-E	011/7180311	n/a	n/a
588	Maturo	Controller	NCD	029/7180311	n/a	n/a
591	Rohde & Schwarz	Receiver	ESU 40	100244/040	7/9/2019	12
608	Rohde & Schwarz	Switch Matrix	OSP 120	101227	lab verification	n/a
628	Maturo	Antenna mast	CAM 4.0-P	224/19590716	n/a	n/a
629	Maturo	Kippeinrichtung	KE 2.5-R-M	MAT002	n/a	n/a

Test site: SR 9

ID	Manufacturer	Type	Model	Serial	Calibration Date	Cal. Cycle (months)
423	Bonn Elektronik	Amplifier, Low Noise Pre	BLMA 1840-1A	55929	7/16/2019	12
621	Ahlborn-Almemo	Temperatur-/ Feuchtemessgerät	MA2470-S2	H16080099	3/15/2019	12
634	Rohde & Schwarz	Wireless Devices Test System	TS8997	--	lab verification	12
636	Rohde & Schwarz	switching unit	OSP120	101698	7/19/2019	12
637	Rohde & Schwarz	Spectrum Analyzer	FSV40	101587	7/11/2019	12

8. Report Revision History

Version Number	Revision Details		
	Page No(s)	Clause	Details
1.0	39	-	Initial Version

--- END OF REPORT ---