



# LoRa mPCIe Smart Gateway Card Data Sheet

# Low-Power Long Range (LoRa<sup>®</sup>) Technology mPCIe Smart Gateway Card for US (SG900X)

## General Features

- Supports LoRa<sup>®</sup> RF Packets
- Up to eight receive and one transmit channel(s)
- mPCIe physical connector
- mPCIe interface with built-in control protocol
  - USB CDC Device (SG9001)
  - UART Device (SG9002)
- Compact form factor 57.0 mm x 30.0 mm
- Environmentally friendly RoHS compliant
- Compliance:
  - US Version (SG900X):  
Certified to FCC Modular Transmitter Standards
- Device Firmware Upgrade (DFU)

## Operational

- Single operating voltage: 3.0V to 3.6V (3.3V nominal)
- Temperature range: -40 to +85 °C
- Supports LoRa<sup>®</sup> Technology and FSK modulations
- Integrated frequency matched RF front end, RF transceiver, baseband processor, and MCU

## Description

OccamSmart's SG900X mPCIe Smart Gateway Card provides an easy to use, low-power solution for long range wireless data reception. The module offers eight LoRa<sup>®</sup> Technology receive channels capable of 125 kHz Bandwidth (BW), as well as a singular channel capable of 125, 250 or 500 kHz BW.

Beyond its receiver capability, the modules provide a single flexible transmit channel. This transmit channel is capable of both LoRa Technology and FSK/GFSK modulations at multiple bandwidths (LoRa Technology) or baud rates (FSK/GFSK).

The multi-channel, flexible nature of this module makes it ideal for use in LoRa Technology gateway applications.

The advanced command protocol available over the mPCIe interface provides complete control over the full capabilities of the RF subsystem in addition to packet reception and transmission.

## Applications

Applications deploying LoRa Technology where gateway devices are required include:

- Automated Meter Reading
- Home and Building Automation
- Wireless Alarm and Security Systems
- Industrial Monitoring and Control
- Machine to Machine (M2M)
- Internet of Things (IoT)

## TABLE OF CONTENTS

DEVICE OVERVIEW .....	4
GENERAL SPECIFICATIONS .....	6
TYPICAL HARDWARE CONNECTIONS .....	10
APPLICATION INFORMATION .....	12
REGULATORY APPROVAL .....	14
APPENDIX A: REVISION HISTORY .....	17
THE OCCAMSMART WEB SITE .....	19
CUSTOMER CHANGE NOTIFICATION SERVICE .....	19
CUSTOMER SUPPORT .....	19
PRODUCT IDENTIFICATION SYSTEM .....	20

### TO OUR VALUED CUSTOMERS

It is our intention to provide our valued customers with the best documentation possible to ensure successful use of your OccamSmart products. To this end, we will continue to improve our publications to better suit your needs. Our publications will be refined and enhanced as new volumes and updates are introduced.

If you have any questions or comments regarding this publication, please contact the Marketing Communications Department via E-mail at [docerrors@occamsmart.com](mailto:docerrors@occamsmart.com). We welcome your feedback.

#### Most Current Data Sheet

To obtain the most up-to-date version of this data sheet, please register at our Worldwide Web site at:

<http://www.occamsmart.com>

You can determine the version of a data sheet by examining its literature number found on the bottom outside corner of any page. The last character of the literature number is the version number, (e.g., SG900X-DSD-A is version A of document SG900X-DS).

#### Errata

An errata sheet, describing minor operational differences from the data sheet and recommended workarounds, may exist for current devices. As device/documentation issues become known to us, we will publish an errata sheet. The errata will specify the revision of silicon and revision of document to which it applies.

To determine if an errata sheet exists for a particular device, please check with one of the following:

- OccamSmart's Worldwide Web site; <http://www.occamsmart.com>
- Your local OccamSmart sales office (see last page)

When contacting a sales office, please specify which device, revision of silicon and data sheet (include literature number) you are using.

#### Customer Notification System

Register on our web site at <http://www.occamsmart.com> to receive the most current information on all of our products.

## 1.0 DEVICE OVERVIEW

The SG900X mPCIe Smart Gateway Card features LoRa Technology RF modulation, which provides long range spread spectrum communication with high interference immunity.

Each module supports eight (8) receive channels allowing it to receive up to eight LoRa Technology modulated packets simultaneously. By using LoRa Technology modulation technique, the SG900X mPCIe Smart Gateway Card can potentially achieve a receiver sensitivity of -146 dBm. When combined with LoRa Technology transmission devices, the SG900X mPCIe Smart Gateway Card provides a system with an industry leading link budget, making it optimal for applications requiring extended range and robustness.

The SG900X mPCIe Smart Gateway Card also contain an integrated output power amplifier (LNA) providing optimal downlink signal levels.

LoRa Technology modulation also provides significant advantages in both blocking and selectivity compared to conventional modulation techniques, solving the traditional design compromise between extended range, interference immunity, and low-power consumption.

The SG900X mPCIe Smart Gateway Card deliver exceptional RF selectivity and their multi-channel performance make them ideal for use in LoRa Technology gateway applications.

Figure 1-1 and Figure 1-2 show the top view and the block diagram of the module.

**FIGURE 1-1: TOP VIEW**



**FIGURE 1-2: BLOCK DIAGRAM**

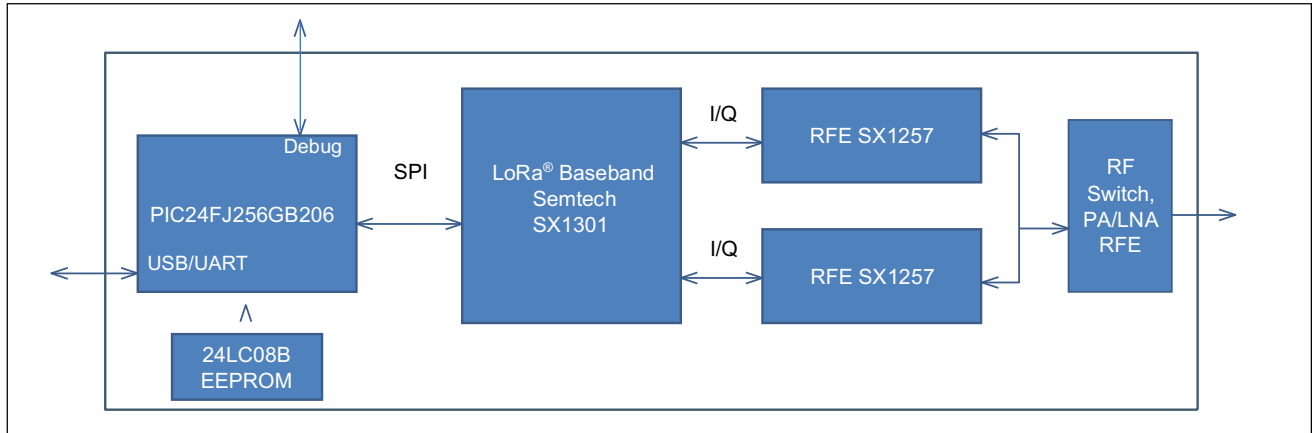

Table 1-1 describes the pins of the module.

**TABLE 1-1: PIN DESCRIPTION**

Pin	Symbol	Type	Description
1	NC	—	Not Connected
2	VCC	Power	Positive Supply Terminal
3	NC	—	Not Connected
4	VSS	Power	Ground Supply Terminal
5	PPS	Input	GPS PPS Input signal (future use)
6	NC	—	Not Connected
7	NC	—	Not Connected
8	NC	—	Not Connected
9	VSS	Power	Ground Supply Terminal
10	NC	—	Not Connected

## LoRa mPCIe Smart Gateway Card Data Sheet

**TABLE 1-1: PIN DESCRIPTION (CONTINUED)**

Pin	Symbol	Type	Description
11	NC	—	Not Connected
12	NC	—	Not Connected
13	NC	—	Not Connected
14	NC	—	Not Connected
15	VSS	Power	Ground Supply Terminal
16	NC	—	Not Connected
17	HOST_URX	Input	Host UART Receive Input (SG9002 only)
18	VSS	Power	Ground Supply Terminal
19	HOST_UTX	Output	Host UART Transmit Output (SG9002 only)
20	RF_ENABLE	Input	RF Enable Input
21	VSS	Power	Ground Supply Terminal
22	RESET	Input	Reset Module Input
23	NC	—	Not Connected
24	VDD	Power	Positive Supply Terminal
25	NC	—	Not Connected
26	VSS	Power	Ground Supply Terminal
27	VSS	Power	Ground Supply Terminal
28	NC	—	Not Connected
29	VSS	Power	Ground Supply Terminal
30	NC	I—	Not Connected
31	NC	—	Not Connected
32	NC	—	Not Connected
33	NC	—	Not Connected
34	VSS	Power	Ground Supply Terminal
35	VSS	Power	Ground Supply Terminal
36	USB_D-	Input/ Output	Host USB D-
37	VSS	Power	Ground Supply Terminal
38	USB_D+	Input/ Output	Host USB D+
39	VDD	Power	Positive Supply Terminal
40	VSS	Power	Ground Supply Terminal
41	VDD	Power	Positive Supply Terminal
42	LED1	Output	LED1 Output
43	VSS	Power	Ground Supply Terminal
44	LED2	Output	LED2 Output
45	NC	—	Not Connected
46	LED3	Output	LED3 Output
47	NC	—	Not Connected
48	PIC_DETECT	Input/ Output	PCI Bus Detect Input. (future use)
49	NC	—	Not Connected
50	VSS	Power	Ground Supply Terminal
51	NC	—	Not Connected
52	VDD	Power	Positive Supply Terminal

## LoRa mPCIe Smart Gateway Card Data Sheet

### 2.0 GENERAL SPECIFICATIONS

Table 2-1 provide the general specifications for the module. Table 2-2 through Table 2-4 provide the electrical characteristics, RF receiver characteristics, LoRa Technology data rate and sensitivity versus spreading factor.

**TABLE 2-1: GENERAL SPECIFICATION**

Specification	Description
Frequency Band – US modulation	902.000 MHz to 928.000 MHz
Modulation Method	LoRa <sup>®</sup> Technology modulation
Maximum Over-the-Air Data Rate	21875 bps (LoRa Technology, see Table 2-4) <sup>(1)</sup>
RF Connection	On-board U.FL connector
Interface	mPCIe: USB (SG9001) and UART (SG9002)
Operation Range	Up to 15 km coverage at suburban; up to 5 km coverage at urban area
RF TX Power – SG900X	Adjustable, < +27.0 dBm <sup>(2)</sup>
Generated Conductive Harmonics Level	Below -70 dBm
Temperature (operating)	-40°C to +85°C
Temperature (storage)	-40°C to +115°C
Humidity	10% ~ 90% Non-condensing

**Note 1:** Depends on modulation and Expand Spreading Factor (SF).

**Note 2:** TX power is adjustable. For TX power settings and corresponding RF Output power, refer to Table2-7.

**TABLE 2-2: ELECTRICAL CHARACTERISTICS**

Parameter	Min.	Typ.	Max.	Units
Supply Voltage	3.0	—	3.6	V
Voltage on any pin with respect to VSS (except VDD)	-0.3	—	-VDD + 0.3	V
Voltage on VDD with respect to VSS	-0.3	—	3.9	V
Input Clamp Current (IIK) (VI < 0 or VI > VDD)	—	—	+/-20	mA
Output Camp Current (IOK) (VO < 0 or VO > VDD)	—	—	+/-20	mA
GPIO sink/source current each	—	—	25/25	mA
Total GPIO sink/source current	—	—	200/185	mA
RAM Data Retention Voltage (in Sleep mode or Reset state)	1.5	—	—	V
VDD Start Voltage to ensure internal Power-on Reset signal	—	—	0.7	V
VDD Rise Rate to ensure internal Power-on Reset signal	0.05	—	—	V/ms
Brown-out Reset Voltage	1.75	1.9	2.05	V
Logic Input Low Voltage	—	—	0.15 x VDD	V
Logic Input High Voltage	0.8 x VDD	—	-	V
Input Leakage at <25°C (VSS<VPIN<VDD, Pin at high-impedance)	—	0.1	50	nA

## LoRa mPCIe Smart Gateway Card Data Sheet

**TABLE 2-2: ELECTRICAL CHARACTERISTICS (CONTINUED)**

Parameter	Min.	Typ.	Max.	Units
Input Leakage at +60°C (VSS<VPIN<VDD, Pin at high-impedance)	—	0.7	100	nA
RF Input Level	—	0	+6	dBm

**TABLE 2-3: RF RECEIVER CHARACTERISTICS**

Descriptions	Conditions	Typ	Unit
LoRa Technology sensitivity at SF12 : IF8 path	BW = 125 kHz	-140	dBm
	BW = 250 kHz	-137	
	BW = 500 kHz	-134	
LoRa Technology sensitivity at SF12 : IF0 to 7 paths	BW = 125 kHz	-140	dBm
Receiver CW interferer rejection at 1Mhz offset at SF12	BW = 125 kHz	+80	dB
Co-channel rejection at SF12	Wanted signal 10 dB above sensitivity	+25	dB
LoRa Technology sensitivity at SF7 : IF8 path	BW = 125 kHz	-126	dBm
	BW = 250 kHz	-123	
	BW = 500 kHz	-120	
LoRa Technology sensitivity at SF7 : IF0 to 7 paths	BW = 125 kHz	-126	dBm
Receiver CW interferer rejection at 1 Mhz offset	BW = 125 kHz	+70	dB
Co-channel rejection at SF7	Wanted signal 10 dB above sensitivity	+9	dB
FSK sensitivity	FDev = 50 kHz, Bit Rate = 100 kb/s	-103	dBm
Bit rate FSK <sup>(1)</sup>	Programmable	1.2 to 100	kbps
Frequency deviation (FDev), FSK	Programmable	0.6 to 200	kHz

**Note 1:** Bit rate limited by:  $FDev + \text{Bit Rate}/2 < 250 \text{ kHz}$

**TABLE 2-4: LoRa TECHNOLOGY DATA RATE (BPS) AND SENSITIVITY VERSUS SPREADING FACTOR (SF)**

SF	125 kHz		250 kHz <sup>(1)</sup>		500 kHz <sup>(1)</sup>	
	Data Rate	Sensitivity	Data Rate	Sensitivity	Data Rate	Sensitivity
7	5496	-130.0	10938	-127.0	21875	-124.0
8	2125	-132.5	6250	-129.5	12500	-126.5
9	1758	-135.0	3516	-132.0	7031	-129.0
10	977	-137.5	1953	-134.5	3906	-131.5
11	537	-140.0	1074	-137.0	2148	-134.0
12	293	-142.5	586	-139.5	1172	-136.5

**Note 1:** 250 kHz and 500 kHz LoRa Technology bandwidths are available *only* on IF8.

## LoRa mPCIe Smart Gateway Card Data Sheet

Table 2-5 through Table 2-7 provide the current consumption, dimensions of the modules and the RF output power versus TX power settings.

**TABLE 2-5: CURRENT CONSUMPTION (3.3V)**

Mode	Current (Typical) mA	Current (Max.) mA
RF Idle	75	100
RX Active	570	850
TX Active	570	900

**TABLE 2-6: MODULE DIMENSIONS**

Parameter	Value
Dimensions	57.0 x 30.0 mm
Weight	14g

**TABLE 2-7: RF OUTPUT POWER (DBM) VERSUS TX POWER SETTING (NOMINAL)**

Setting	Power	Setting	Power	Setting	Power	Setting	Power	Setting	Power
-6	-6	1	0	8	6	15	14	22	20
-5	-6	2	0	9	6	16	16	23	23
-4	-6	3	3	10	10	17	16	24	23
-3	-3	4	3	11	11	18	16	25	25
-2	-3	5	3	12	12	19	16	26	26
-1	-3	6	6	13	13	20	20	27	27
0	0	7	6	14	14	21	20		



NOTES:

### 3.0 TYPICAL HARDWARE CONNECTIONS

Figure 3-1 shows the typical hardware connections for the module. Interfacing to the module requires connecting to the signals provided on the SG900X mPCIe connector as listed in Table 1-1. Specific interface connections are discussed in this chapter.

FIGURE 3-1: HARDWARE CONNECTIONS

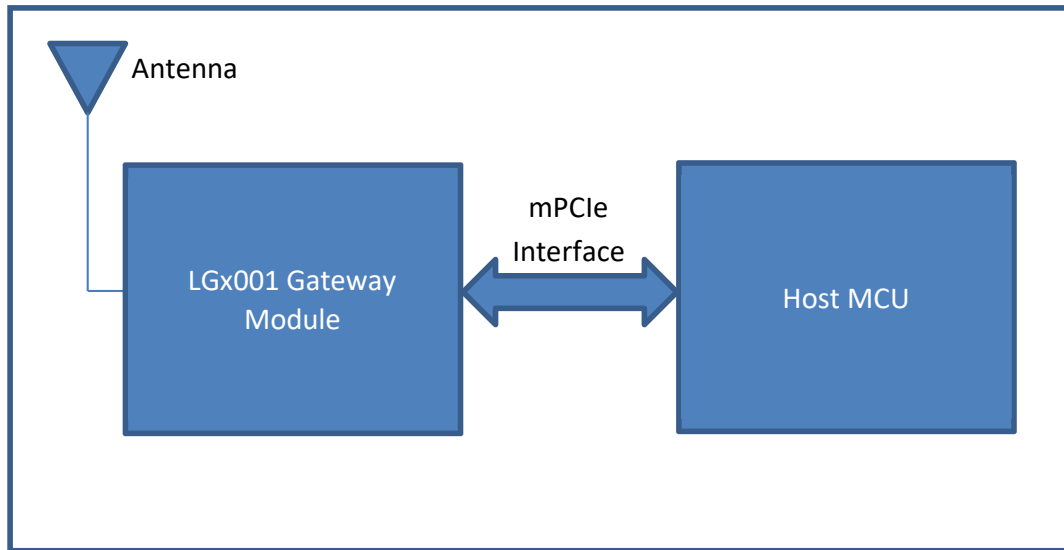

#### 3.1 INTERFACE TO HOST MCU

The SG9001 mPCIe Smart Gateway Card uses the USB signals of the mPCIe interface. During startup, the module performs the required USB negotiation with the host MCU before enumerating as a USB CDC serial device.

The SG9002 mPCIe Smart Gateway Card uses the UART signals of the mPCIe interface. These signals are always present and require no configuration.

Table 3-1 shows the serial interface parameters required to communicate with the card on both interfaces.

TABLE 3-1: UART SETTINGS

Specification	Value
Signal Levels	TTL
Baud Rate	115200 bps
Data bits	8
Parity Bit	No
Stop Bits	1
Hardware Flow Control	No

#### 3.2 RF CONNECTION

The SG900X mPCIe Smart Gateway Card has a U.FL connector for interfacing with an external antenna. For

proper operation, antenna selection must consider frequency band and impedance.

#### 3.3 POWER PINS

The SG900X mPCIe Smart Gateway Card has multiple power and ground pins available on the mPCIe connector.

It is recommended that all power and ground pins be used when connecting to the module.

#### 3.4 RESET PIN

The SG900X mPCIe Smart Gateway Card has an active-low reset input. Pulling this signal low during normal operation will cause the module to execute a reset cycle.

#### 3.5 RF\_ENABLE

The SG900X mPCIe Smart Gateway Card has an input signal used to enable the RF radio on the module. A low level on the RF\_ENABLE pin will disable all RF transmission and reception.

### 3.6 PCI\_DETECT (Future use)

The SG900X mPCIe Smart Gateway Card modules have an input signal used to select the active host interface. This signal is reserved for future use.

### 3.7 LED OUTPUTS

The SG900X mPCIe Smart Gateway Card has three buffered outputs that can sink sufficient current to activate off board LEDs. These signals are entirely controlled by commands from the host MCU.

# LoRa mPCIe Smart Gateway Card Data Sheet

## 4.0 APPLICATION INFORMATION

### 4.1 PHYSICAL DIMENSIONS

Figure 4-1 and Figure 4-2 illustrate the physical dimensions of the SG900X mPCIe Smart Gateway Card.

FIGURE 4-1: TOP AND BOTTOM VIEW

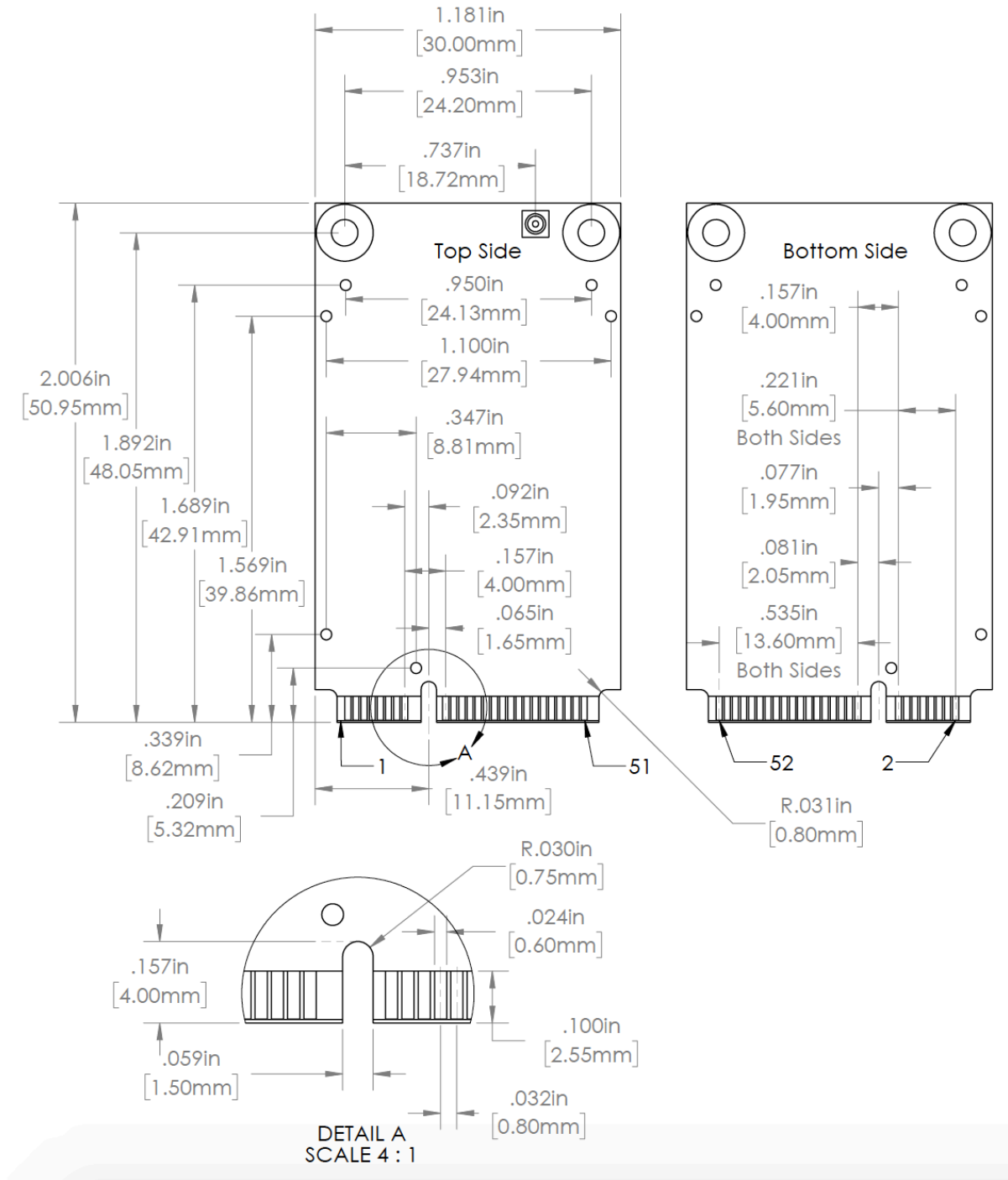
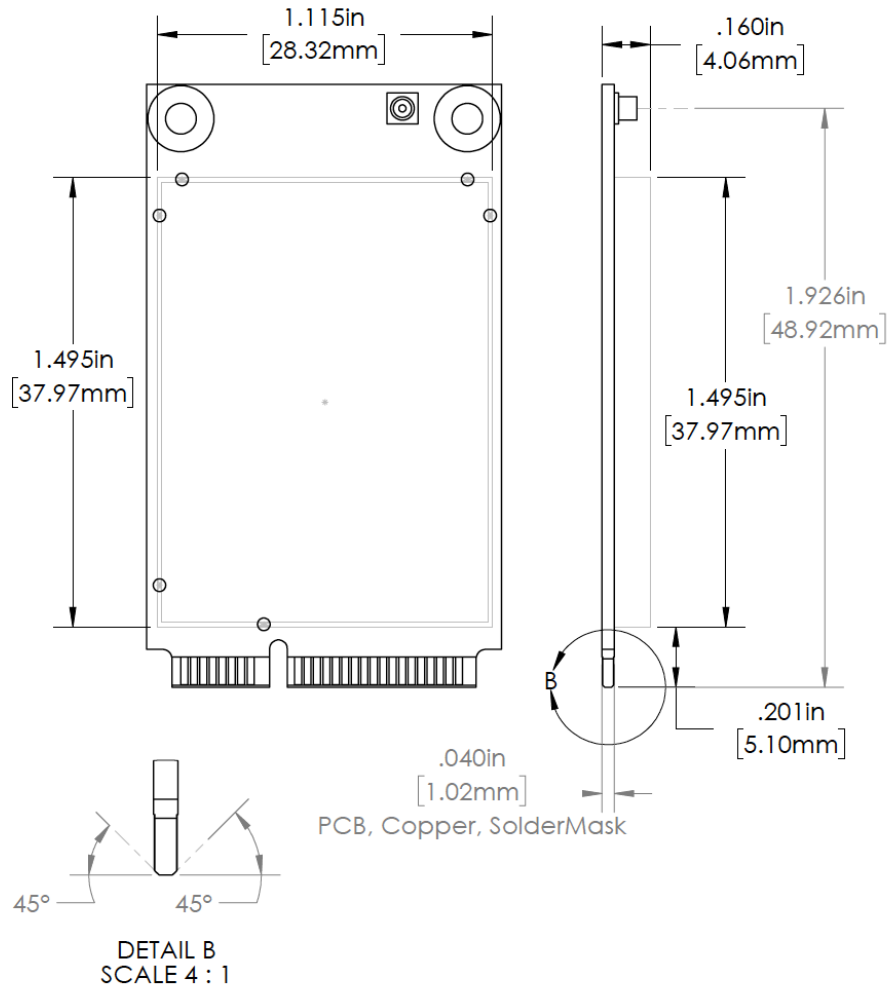

FIGURE 4-2: TOP VIEW WITH SHIELD AND SIDE VIEW



## 4.2 APPROVED ANTENNAS

Modular certification of the SG900X mPCIe Smart Gateway Card is performed with the external antenna type in [Table 4-1](#). For specific regulatory requirements by country, refer to [Section 5.0 “Regulatory Approval”](#).

TABLE 4-1: TESTED EXTERNAL ANTENNA TYPES

Type	Gain (dBi)
Sleeve Dipole	5

## 5.0 REGULATORY APPROVAL

This section outlines the regulatory information for the SG900X mPCIe Smart Gateway Card for the following countries:

- United States (SG900X mPCIe Smart Gateway Card)

### 5.1 UNITED STATES

The SG900X mPCIe Smart Gateway Card has received Federal Communications Commission (FCC) CFR47 Telecommunications, Part 15 Subpart C “Intentional Radiators” modular approval in accordance with Part 15.212 Modular Transmitter approval. Modular approval allows the end user to integrate the SG900X mPCIe Smart Gateway Card into a finished product without obtaining subsequent and separate FCC approvals for intentional radiation, provided no changes or modifications are made to the module circuitry. Changes or modifications could void the user’s authority to operate the equipment. The end user must comply with all of the instructions provided by the Grantee, which indicate installation and/or operating conditions necessary for compliance.

The finished product is required to comply with all applicable FCC equipment authorizations regulations, requirements and equipment functions not associated with the transmitter module portion. For example, compliance must be demonstrated to regulations for other transmitter components within the host product; to requirements for unintentional radiators (Part 15 Subpart B “Unintentional Radiators”), such as digital devices, computer peripherals, radio receivers, etc.; and to additional authorization requirements for the non-transmitter functions on the transmitter module (i.e., Verification, or Declaration of Conformity) (e.g., transmitter modules may also contain digital logic functions) as appropriate.

#### 5.1.1 LABELING AND USER INFORMATION REQUIREMENTS

The SG900X mPCIe Smart Gateway Card has been labeled with its own FCC ID number, and if the FCC ID is not visible when the module is installed inside another device, then the outside of the finished product into which the module is installed must also display a label referring to the enclosed module. This exterior label can use wording as follows:

Contains FCC ID: 2ANX6-SG9001-2  
This device complies with Part 15 of the FCC Rules. Operation is subject to the following two conditions:  
(1) this device may not cause harmful interference, and  
(2) this device must accept any interference received, including interference that may cause undesired operation.

A user's manual for the finished product should include the following statement:

This equipment has been tested and found to comply with the limits for a Class B digital device, pursuant to part 15 of the FCC Rules. These limits are designed to provide reasonable protection against harmful interference in a residential installation. This equipment generates, uses and can radiate radio frequency energy, and if not installed and used in accordance with the instructions, may cause harmful interference to radio communications. However, there is no guarantee that interference will not occur in a particular installation. If this equipment does cause harmful interference to radio or television reception, which can be determined by turning the equipment off and on, the user is encouraged to try to correct the interference by one or more of the following measures:

- Reorient or relocate the receiving antenna.
- Increase the separation between the equipment and receiver.
- Connect the equipment into an outlet on a circuit different from that to which the receiver is connected.
- Consult the dealer or an experienced radio/TV technician for help.

Additional information on labeling and user information requirements for Part 15 devices can be found in KDB Publication 784748 available at the FCC Office of Engineering and Technology (OET) Laboratory Division Knowledge Database (KDB) <https://apps.fcc.gov/oetcf/kdb/index.cfm>.

## 5.1.2 RF EXPOSURE

All transmitters regulated by FCC must comply with RF exposure requirements. KDB 447498 General RF Exposure Guidance provides guidance in determining whether proposed or existing transmitting facilities, operations or devices comply with limits for human exposure to Radio Frequency (RF) fields adopted by the Federal Communications Commission (FCC).

From the SG900X mPCIe Smart Gateway Card FCC Grant: Output power listed is conducted. This grant is valid only when the module is sold to OEM integrators and must be installed by the OEM or OEM integrators. This transmitter is restricted for use with the specific antenna(s) tested in this application for Certification and must not be co-located or operating in conjunction with any other antenna or transmitters within a host device, except in accordance with FCC multi-transmitter product procedures.

## 5.1.3 APPROVED EXTERNAL ANTENNA TYPES

To maintain modular approval in the United States, only the antenna types that have been tested shall be used. It is permissible to use different antenna manufacturer provided the same antenna type and antenna gain (equal to or less than) is used.

Testing of the SG900X mPCIe Smart Gateway Card was performed with the antenna types listed in [Table 4-1 Tested External Antenna Types](#).

## 5.1.4 HELPFUL WEB SITES

Federal Communications Commission (FCC):  
<http://www.fcc.gov>

FCC Office of Engineering and Technology (OET)  
Laboratory Division Knowledge Database (KDB):  
<https://apps.fcc.gov/oetcf/kdb/index.cfm>

## 5.2 CANADA

The module has been certified for use in Canada under Industry Canada (IC) Radio Standards Specification (RSS) RSS-247 and RSS-Gen. Modular approval permits the installation of a module in a host device without the need to recertify the device.

### 5.2.1 LABELING AND USER INFORMATION REQUIREMENTS

Labeling Requirements for the Host Device (from Section 3.1, RSS-Gen, Issue 4, November 13, 2014): The host device shall be properly labeled to identify the module within the host device. The Industry Canada certification label of a module shall be clearly visible at all times when installed in the host device, otherwise the host device must be labeled to display the Industry Canada certification number of the module, preceded

by the words "Contains transmitter module", or the word "Contains", or similar wording expressing the same meaning, as follows:

Contains transmitter module IC: 23319-SG90012

User Manual Notice for License-Exempt Radio Apparatus (from Section 8.4 RSS-Gen, Issue 4, November 13, 2014): User manuals of license-exempt radio apparatus shall contain the following or equivalent notice in a conspicuous location in the user manual or alternatively on the device or both:

This device complies with Industry Canada license-exempt RSS standard(s). Operation is subject to the following two conditions: (1) this device may not cause interference, and (2) this device must accept any interference, including interference that may cause undesired operation of the device.

Le présent appareil est conforme aux CNR d'Industrie Canada applicables aux appareils radio exempts de licence. L'exploitation est autorisée aux deux conditions suivantes: (1) l'appareil ne doit pas produire de brouillage, et (2) l'utilisateur de l'appareil doit accepter tout brouillage radioélectrique subi, même si le brouillage est susceptible d'en compromettre le fonctionnement.

Transmitter Antenna (from Section 8.3 RSS-Gen, Issue 4, November 13, 2014): User manuals for transmitters shall display the following notice in a conspicuous location:

Under Industry Canada regulations, this radio transmitter may only operate using an antenna of a type and maximum (or lesser) gain approved for the transmitter by Industry Canada. To reduce potential radio interference to other users, the antenna type and its gain should be so chosen that the equivalent isotropically radiated power (e.i.r.p.) is not more than that necessary for successful communication.

Conformément à la réglementation d'Industrie Canada, le présent émetteur radio peut fonctionner avec une antenne d'un type et d'un gain maximal (ou inférieur) approuvé pour l'émetteur par Industrie Canada. Dans le but de réduire les risques de brouillage radioélectrique à l'intention des autres utilisateurs, il faut choisir le type d'antenne et son gain de sorte que la puissance isotrope rayonnée équivalente (p.i.r.e.) ne dépasse pas l'intensité nécessaire à l'établissement d'une communication satisfaisante.

The above notice may be affixed to the device instead of displayed in the user manual.

User manuals for transmitters equipped with detachable antennas shall also contain the following notice in a conspicuous location:

This radio transmitter (identify the device by certification number, or model number if Category II) has been approved by Industry Canada to operate with the antenna types listed below with the maximum permissible gain and required antenna impedance for each antenna type indicated. Antenna types not included in this list, having a gain greater than the maximum gain indicated for that type, are strictly prohibited for use with this device.

Conformément à la réglementation d'Industrie Canada, le présent émetteur radio peut fonctionner avec une antenne d'un type et d'un gain maximal (ou inférieur) approuvé pour l'émetteur par Industrie Canada. Dans le but de réduire les risques de brouillage radioélectrique à l'intention des autres utilisateurs, il faut choisir le type d'antenne et son gain de sorte que la puissance isotrope rayonnée équivalente (p.i.r.e.) ne dépasse pas l'intensité nécessaire à l'établissement d'une communication satisfaisante.

Immediately following the above notice, the manufacturer shall provide a list of all antenna types approved for use with the transmitter, indicating the maximum permissible antenna gain (in dBi) and required impedance for each.

### 5.2.2 RF EXPOSURE

All transmitters regulated by IC must comply with RF exposure requirements listed in RSS-102 - Radio Frequency (RF) Exposure Compliance of Radio Communication Apparatus (All Frequency Bands). Currently this device is approved for use for when 20 cm can be maintained between the antenna and users.

Specific Absorption Rate (SAR) evaluation is required if the separation distance between the user and/or bystander and the antenna and/or radiating element of the device is less than or equal to 20 cm. Exceptions are listed in RSS-102. Note that integration < 20 cm will require further certification with IC such as a Multiple listing and Class IV Permissive Change application.

Tous les émetteurs régulés par Industrie Canada doivent être conformes à la notice RSS-102 d'Industrie

Canada concernant la Conformité des appareils de radiocommunication aux limites d'exposition humaine aux radiofréquences (toutes bandes de fréquences). Ce produit est ainsi approuvé pour une utilisation d'au moins 20 cm entre l'antenne et toute personne à proximité.

Une évaluation du Débit d'Absorption Spécifique (DAS) est requise si cette distance de séparation est inférieure ou égale à 20 cm. Des exceptions sont toutefois répertoriés dans la notice RSS-102. Mais il est souligné que l'utilisation d'un dispositif à moins de 20 cm nécessite une certification supplémentaire avec Industrie Canada, comme un complément d'information et l'application à la notice de Changement Permissif de Classe IV.

### 5.2.3 APPROVED EXTERNAL ANTENNA TYPES

Transmitter Antenna (from Section 8.3 RSS-Gen, Issue 4, November 13, 2014):

The SG900X mPCIe Smart Gateway Card can only be sold or operated with antennas with which it was approved. Transmitter may be approved with multiple antenna types. An antenna type comprises antennas having similar in-band and out-of-band radiation patterns. Testing shall be performed using the highest gain antenna of each combination of transmitter and antenna type for which approval is being sought, with the transmitter output power set at the maximum level. Any antenna of the same type having equal or lesser gain as an antenna that had been successfully tested with the transmitter, will also be considered approved with the transmitter, and may be used and marketed with the transmitter.

When a measurement at the antenna connector is used to determine RF output power, the effective gain of the device's antenna shall be stated, based on measurement or on data from the antenna manufacturer. For transmitters of output power greater than 10 milliwatts, the total antenna gain shall be added to the measured RF output power to demonstrate compliance to the specified radiated power limits.

Testing of the SG900X mPCIe Smart Gateway Card was performed with the antenna types listed in [Table 4-1 Tested External Antenna Types](#).

### 5.2.4 HELPFUL WEBSITES

Industry Canada: <http://www.ic.gc.ca/>



## APPENDIX A: REVISION HISTORY

Revision A (February 2018)

This is the initial released version of the document.

**NOTES:**

### THE OCCAMSMART WEB SITE

OccamSmart provides online support via our WWW site at [www.occamsmart.com](http://www.occamsmart.com). This web site is used as a means to make files and information easily available to customers. Accessible by using your favorite Internet browser, the web site contains the following information:

- **Product Support** – Data sheets and errata, application notes and sample programs, design resources, user's guides and hardware support documents, latest software releases and archived software
- **General Technical Support** – Frequently Asked Questions (FAQ), technical support requests, online discussion groups, OccamSmart consultant program member listing
- **Business of OccamSmart** – Product selector and ordering guides, latest OccamSmart press releases, listing of seminars and events, listings of OccamSmart sales offices, distributors and factory representatives

### CUSTOMER CHANGE NOTIFICATION SERVICE

OccamSmart's customer notification service helps keep customers current on OccamSmart products. Subscribers will receive e-mail notification whenever there are changes, updates, revisions or errata related to a specified product family or development tool of interest.

To register, access the OccamSmart web site at [www.occamsmart.com](http://www.occamsmart.com). Under "Support", click on "Customer Change Notification" and follow the registration instructions.

### CUSTOMER SUPPORT

Users of OccamSmart products can receive assistance through several channels:

- Distributor or Representative
- Local Sales Office
- Field Application Engineer (FAE)
- Technical Support

Customers should contact their distributor, representative or Field Application Engineer (FAE) for support. Local sales offices are also available to help customers. A listing of sales offices and locations is included in the back of this document.

Technical support is available through the web site at: <http://occamsmart.com/support>

## PRODUCT IDENTIFICATION SYSTEM

For US (915MHz):

- **SG9001: USB interface**
- **SG9002: Serial interface**

For EU (868MHz):

- **SG8001: USB interface**
- **SG8002: Serial interface**

## LoRa mPCIe Smart Gateway Card Data Sheet

---

### Note the following details of the code protection feature on OccamSmart devices:

- OccamSmart products meet the specification contained in their particular OccamSmart Data Sheet.
- OccamSmart believes that its family of products is one of the most secure families of its kind on the market today, when used in the intended manner and under normal conditions.
- There are dishonest and possibly illegal methods used to breach the code protection feature. All of these methods, to our knowledge, require using the OccamSmart products in a manner outside the operating specifications contained in OccamSmart's Data Sheets. Most likely, the person doing so is engaged in theft of intellectual property.
- OccamSmart is willing to work with the customer who is concerned about the integrity of their code.
- Neither OccamSmart nor any other semiconductor manufacturer can guarantee the security of their code. Code protection does not mean that we are guaranteeing the product as "unbreakable."

Code protection is constantly evolving. We at OccamSmart are committed to continuously improving the code protection features of our products. Attempts to break OccamSmart's code protection feature may be a violation of the Digital Millennium Copyright Act. If such acts allow unauthorized access to your software or other copyrighted work, you may have a right to sue for relief under that Act.

Information contained in this publication regarding device applications and the like is provided only for your convenience and may be superseded by updates. It is your responsibility to ensure that your application meets with your specifications. OCCAMSMART MAKES NO REPRESENTATIONS OR WARRANTIES OF ANY KIND WHETHER EXPRESS OR IMPLIED, WRITTEN OR ORAL, STATUTORY OR OTHERWISE, RELATED TO THE INFORMATION, INCLUDING BUT NOT LIMITED TO ITS CONDITION, QUALITY, PERFORMANCE, MERCHANTABILITY OR FITNESS FOR PURPOSE. OccamSmart disclaims all liability arising from this information and its use. Use of OccamSmart devices in life support and/or safety applications is entirely at the buyer's risk, and the buyer agrees to defend, indemnify and hold harmless OccamSmart from any and all damages, claims, suits, or expenses resulting from such use. No licenses are conveyed, implicitly or otherwise, under any OccamSmart intellectual property rights unless otherwise stated.

### Trademarks & Legal Disclaimer

The OccamSmart name and logo are registered trademarks of Occammd, LLC in the U.S.A. and other countries.

OccamSmart and Occam Technology Group are a registered trade names of Occammd, LLC.

© 2018, Occam Technology Group, All Rights Reserved. ISBN:

## WORLDWIDE SALES AND SERVICE

**AMERICAS**  
Corporate Office

124 South Franklin  
Street, Tampa, FL 33602  
Tel: 844-622-2663

Technical Support:  
<http://www.occamsmart.com/support>

Web Address:  
[www.occamsmart.com](http://www.occamsmart.com)