



SAR Test Report

FOR:

Manufacturer: FIO Corporation

Model Number: V200

FCC ID: 2ANVA-V200

IC Certification Number: 22342-V200

Test Report #: SAR-FIOIN-002-17001

Date of Report: 2018-2-12



CETECOM Inc.

411 Dixon Landing Road ♦ Milpitas, CA 95035 ♦ U.S.A.

Phone: + 1 (408) 586 6200 ♦ Fax: + 1 (408) 586 6299 ♦ E-mail: info@cetecom.com ♦ <http://www.cetecom.com>

CETECOM Inc. is a Delaware Corporation with Corporation number: 2905571

TABLE OF CONTENTS

1. Assessment	4
2. Administrative Data	5
2.1. Identification of the Testing Laboratory Issuing the SAR Test Report.....	5
2.2. Identification of the Client and Manufacturer.....	5
3. Equipment under Test (EUT)	6
3.1. General Specification of the Equipment under Test.....	6
3.2. Antenna Information	7
3.3. Identification of the Equipment Under Test (EUT).....	7
3.4. Identification of Accessory equipment.....	7
3.5. Maximum SAR Values.....	7
4. Test Result Summary	8
4.1. Test Positions and Configurations	8
4.2. Conducted Measurements.....	9
4.3. SAR Results for Extremity.....	10
4.4. SAR Measurement Variability	11
4.5. Simultaneous SAR Evaluation	11
4.6. Dipole verification.....	12
5. Subject of Investigation	13
5.1. The IEEE Standard C95.1 , FCC Exposure Criteria, and IC Exposure Criteria.....	13
5.2. SAR Limit.....	13
6. Measurement Procedure	14
6.1. General Requirements.....	14
6.2. Body-worn and Other Configurations.....	15
6.3. System Check.....	15
6.4. Procedure for assessing the peak spatial-average SAR.....	17
6.5. Determination of the largest peak spatial-average SAR.....	18
6.6. SAR Scaling Using the Tune-Up Scaling Factor	19
7. The Measurement System	20
7.1. Robot system specification.....	20
7.2. Isotropic E-Field Probe for Dosimetry Measurements	21
7.3. Data Acquisition Electronics	21
7.4. Phantoms.....	21

7.5. Interpolation and Extrapolation schemes.....	21
8. Uncertainty Assessment.....	22
8.1. Measurement Uncertainty Budget According to IEEE 1528:2013	22
8.2. Measurement Uncertainty Budget According to EN 62209-2.....	23
8.3. Measurement Uncertainty Budget According to IEC/EN 62209-1 and IEC/EN 62209-2.....	24
9. References.....	25
10. Report History.....	26

1. Assessment

The following device was evaluated against the limits for general population uncontrolled exposure specified in FCC 2.1093 and RSS 102, Issue 5 according to measurement procedures specified in FCC regulation as listed in chapter 5, IEEE 1528:2013 and IEC 62209-2:2010 and no deviations were ascertained during the course of the tests performed.

Manufacturer	Description	Model #
FIO Corporation	Portable camera-based diagnostic device	V200

Responsible for Testing Laboratory:

2018-02-12	RC&E	James Donnellan (EMC Lab Manager)	
Date	Section	Name	Signature

Responsible for the Report:

2018-02-12	RC&E	Joseph Pacheco (SAR Technician)	
Date	Section	Name	Signature

The test results of this test report relate exclusively to the test item specified in Section 3. CETECOM Inc. USA does not assume responsibility for any conclusions and generalizations drawn from the test results with regard to other specimens or samples of the type of the equipment represented by the test item. The test report may only be reproduced or published in full. Reproduction or publication of extracts from the report requires the prior written approval of CETECOM Inc. USA.

2. Administrative Data

2.1. Identification of the Testing Laboratory Issuing the SAR Test Report

Company Name	CETECOM Inc.
Department	Compliance
Address	411 Dixon Landing Road Milpitas, CA 95035 U.S.A.
Telephone	+1 (408) 586 6200
Fax	+1 (408) 586 6299
Industry Canada Company Number	3462B
Test Lab Manager	James Donnellan
Responsible Project Manager	Ruther Navarro

2.2. Identification of the Client and Manufacturer

	Client	Manufacturer (if different)
Company	FIO Corporation	Same as Client
Street Address	111 Queen St. East, Suite 500	-----
City/Zip Code	Toronto, ON M5C 1S2	-----
Country	Canada	-----

3. Equipment under Test (EUT)

3.1. General Specification of the Equipment under Test

Model No	V200
FCC ID	2ANVA-V200
IC Certification Number	22342-V200
Product Marketing Name (PMN)	Deki Reader
Hardware Version Identification Number (HMN)	2.0.0.0
Firmware Version Identification Number (FVN)	1.89
Host Marketing Name (HMN)	N/A
Product Type	Portable camera-based diagnostic device (closer than 20 cm to persons)
Prototype/Production	Prototype
RF Exposure Environment	General / Uncontrolled
Dimensions	250 x 110 x 120 (mm)
Exposure Conditions	Personal Wireless Router. Only display side will be touched during use.
Supported Radios	TelitHE910: GSM: 850 900 1800 1900; UMTS FDD: Band I Band II Band IV Band V Band VIII TelitJF2: GPS L1 TiWi-BLE: WLAN 802.11b/g/n: Bluetooth 2.1+EDR; BLE 4.0
Additional Radios¹	N/A
Power Back-Off Modes	N/A
Simultaneous Transmission Configurations	<ul style="list-style-type: none"> • Cellular + WLAN • Cellular + Bluetooth
Date of Testing	10/26/2017 – 1/31/2018

3.2. Antenna Information

Antenna	Type	Internal / External	Frequency (MHz)	Manufacturer Stated Max Peak Gain (dBi)
FXUB63	Flex Antenna	Internal	698-3000	5
FXP.831	Flex Antenna	Internal	2400-5000	2.5

3.3. Identification of the Equipment Under Test (EUT)

EUT #	Serial Number	HW Version	SW Version
1	FH21102	2.0.0.0	1.89
2	FH21104	2.0.0.0	1.89

3.4. Identification of Accessory equipment

AE #	Type	Manufacturer	Model	Serial Number	Comments
1	Battery	Energy Very Endure EVE	Intertek 5000767	17-02-0374	Li-Ion 3.6 [V] 38.2 [Wh]
2	AC Adapter	Glob Tek, Inc.	GTM46101-1005-USB	WR9QA2000USBNMEDR6B	Output: 5 [V] DC

3.5. Maximum SAR Values

Signal Type	Band	Exposure Condition	Measured 10g SAR (W/kg)	Maximum Scaled 10g SAR (W/kg)
GPRS	1900	Touch Screen	0.083	0.107
GPRS	850	Touch Screen	0.080	0.086
WCDMA	Band 2	Touch Screen	0.132	0.214
WCDMA	Band 4	Touch Screen	0.107	0.166
WCDMA	Band 5	Touch Screen	0.044	0.073
802.11b/g/n	2.4 GHz	Touch Screen	0.024	0.046

4. Test Result Summary

4.1. Test Positions and Configurations

Exposure Condition	Distance	Position	Positioning Photo Appendix B
Extremity SAR	0 mm	DUT with frame detached in order for adjoining touch screen to phantom	Photo 3

- WLAN is tested on the channel with the highest measured conducted average power.
- For GSM bands, the uplink timeslot configuration with the highest source-based time-averaged output power is used for full SAR evaluation for exposure positions.
- SAR evaluation for LTE is performed with the bandwidth and RB configuration with the highest output power.
- Measured SAR values are scaled up to the manufacturer's stated output power. These SAR values are the reported SAR values as described in FCC KDB 447498.
- Configurations with multiple SAR values have at least one peak SAR within 2 dB of the primary peak. 5mm.

For test position, the practical use was taken into consideration, and therefore the DUT is only subjected to measurements at touch screen. Accordingly, in the test setup, the DUT outer frame is detached for adjoining touch screen with phantom. Given the dimensions and weight of the DUT, the intended use is for touch screen with the DUT placed on a flat stable surface as documented in the user's guid.

4.2. Conducted Measurements

Signal Type	Worst Case For Time Averaged Power Timeslots /Duty Cycle		Type(s) of Uplink Modulation	Band	Uplink Transmit Frequency Range (MHz)	Measured Maximum Conducted Output Power (dBm)	Declared Maximum Output Power from (dBm)	Scaling factor for reported SAR
(E)GPRS	2	25%	GMSK	GSM 850	824.2 – 848.8	32.7	33	1.07
	2	25%		PCS 1900	1850.2 – 1909.8	28.9	30	1.29
WCDMA	100%		QPSK	FDD II	1850 - 1910	21.9	24	1.62
				FDD IV	1710 - 1755	22.1	24	1.55
				FDD V	824 – 849	21.8	24	1.66
802.11 b/g/n	100%		-	-	2400 – 2483.5	17.29	20.1	1.9

NOTES:

4.3. SAR Results for Extremity

Band	Operation Mode	Channel	Frequency (MHz)	Position	Measured SAR 10g (W/kg)	Measured SAR 1g (W/kg)	Tune Up Power Scaling Factor	Power Drift (dB)	Reported SAR 10g (W/kg)	Results Appendix A
GPRS 1900	GMSK	Uplink Middle	1880	Screen touching phantom. Frame removed	0.083	0.131	1.29	0.63	0.107	Plot 1
GPRS 850	GMSK	Uplink Middle	836.6	Screen touching phantom. Frame removed	0.080	0.120	1.07	0.48	0.086	Plot 2
UMTS II	QPSK	Uplink Middle	1880	Screen touching phantom. Frame removed	0.132	0.220	1.62	0.16	0.214	Plot 3
UMTS IV	QPSK	Uplink Middle	1732.6	Screen touching phantom. Frame removed	0.107	0.182	1.55	0.78	0.166	Plot 4
UMTS V	QPSK	Uplink Middle	836.6	Screen touching phantom. Frame removed	0.044	0.066	1.66	0.76	0.073	Plot 5
802.11 b/g/n	100% Duty Cycle	Uplink Middle	2437	Screen touching phantom. Frame removed	0.024	0.042	1.9	-0.35	0.046	Plot 6

NOTE:

1. Results for Power Drift are excessive due to the low measured SAR results at close to noise floor levels.

4.4. SAR Measurement Variability

SAR measurement variability is assessed when the initial measured 1g SAR is ≥ 0.80 W/kg. If the measured SAR value of the initial repeated measurement is < 1.45 W/kg with $\leq 20\%$ variation, only one repeated measurement is required to affirm that the results are not expected to have substantial variations. A second repeated measurement is required only if the measured results for the initial repeated measurement is within 10% of the SAR limit and vary by more than 20%.

Note: Measurement variability was not needed for this project.

4.5. Simultaneous SAR Evaluation

Antenna	Operation Mode	Reported SAR10g (W/kg)
Cellular	UMTS FDD II	0.214
Wifi	80211 b	0.046
Simultaneous SAR	Co Transmission	0.260

Simultaneous SAR is the worst reported SAR of both Cellular and Bluetooth..

4.6. Dipole verification

Prior to formal testing at each frequencyband, system verification was performed in accordance with IEEE 1528. The 1 Watt reference SAR value is taken from the SPEAG dipole calibration report. All of the testing described in this report was performed within 24 hours of the system verification. The following results were obtained:

Date	Liquid Type	Frequency (MHz)	CW input at dipole feed (Watts)	10g SAR (W/kg) measured	10g SAR (W/kg) from dipole calibration	Difference reference SAR value to normalized SAR	Results (Appendix A)
1-8-2018	MSL	900	0.25	1.55	1.78	0.23	Plot 7
10-30-2017	MSL	1750	0.25	4.52	4.9	0.38	Plot 8
12-19-2017	MSL	1900	0.25	4.84	5.09	0.25	Plot 9
1-30-2018	MSL	2450	0.25	5.58	5.73	0.15	Plot 10

5. Subject of Investigation

The objective of the measurements done by CETECOM Inc. was the dosimetry assessment of the EUT described in section 3. The tests were performed in configurations for devices operated by using ones hand on the touch screen (Localized Limbs assessment). The examinations were carried out with the dosimetry assessment system DASY52 described in Section 6.

5.1. The IEEE Standard C95.1 , FCC Exposure Criteria, and IC Exposure Criteria

The FCC limits are set by CFR 47 FCC rule parts 1.1307 and 2.1093. The IC limits are set by RSS 102, Issue 5 and Safety Code 6 (2015). The limits are derived from the recommendations in IEEE C95.1-1999 (ANSI/IEEE C95.1-1999), "IEEE Standard for Safety Levels with Respect to Human Exposure to Radio Frequency Electromagnetic Fields, 3 kHz to 300 GHz"

5.2. SAR Limit

In this report the comparison between the exposure limits and the SAR data is made using the spatial peak SAR.

Having in mind a worst case consideration, the SAR limit is valid for uncontrolled environment and portable transmitters. The SAR values have to be averaged over a mass of 1g (SAR_{1g}) and/or 10g (SAR_{10g}) with the shape of a cube.

Standard	Exposure Condition	Average SAR (W/kg)	Mass Average (g)
FCC CFR 47 Part 2.1093 (d)(2)	Partial-Body	1.6	1
FCC CFR 47 Part 2.1093 (d)(2)	Hands, Wrists, Feet and Ankles	4.0	10
RSS 102, Issue 5 Safety Code 6 (2015)	Localized Head and Trunk	1.6	1
RSS 102, Issue 5 Safety Code 6 (2015)	Localized Limbs	4.0	10

6. Measurement Procedure

The Federal Communications Commission (FCC) requires routine dosimetry assessment of mobile telecom-communications devices, either by laboratory measurement techniques or by computational modeling, prior to equipment authorization or use. The measurement procedure shall be performed according to IEEE 1528:2013. The following KDB publications have additionally been applied:

- 447498 D01 V06 – General RF Exposure Guidance
- 648474 D04 V01R03 – SAR Evaluation Considerations for Wireless Handsets
- 616217 D04 V01R02 – SAR for Laptop and Tablets
- 865664 D01 V01R04 – SAR measurement 100 MHz to 6 GHz
- 248227 D01 V02R02 – SAR Measurement Procedures for 802.11 a/b/g Transmitters
- 941225 D01 V03R01 – SAR Measurement Procedures for 3G Devices
- 941225 D06 V02R01 – SAR Evaluation Procedures for Portable Devices with Wireless Router Capabilities
- 941225 D07 V01R02 – SAR Evaluation Procedures for UMPC Mini-Tablet Devices

Industry Canada (IC) requirements and measurement techniques regarding RF exposure are described in RSS-102, Issue 5, which refers to the latest version of IEEE 1528 and IEC 62209. IC follows many of the same procedures as applied for compliance with FCC requirements regarding EUT specific technologies and form factors. IC allows the use of the above listed KDBs in most aspects as described in IC Notice 2012-DRS1203 regarding Applicability of Latest FCC RF Exposure KDB Procedures (Publication Date: October 24, 2012) and Other Procedures. Additionally the following guideline is used:

RSS-102 Supplementary Procedures (SPR)-001, January 2011 – SAR Testing Requirements with Regard to Bystanders for Laptop Type Computers with Antennas Built-in on display Screen (Laptop Mode/Tablet Mode)

6.1. General Requirements

SAR evaluation was performed in a laboratory with an environment which avoids influence on SAR measurements by ambient EM sources and any reflection from the environment itself. The ambient temperature was in the range of 18°C to 25°C and 30-70% humidity. Simulating liquid temperature did not deviate more than 2°C throughout SAR evaluation.

6.2. Body-worn and Other Configurations

Test Position

The body-worn configurations shall be tested with the supplied accessories (belt-clips, holsters, etc.) attached to the device in normal use configuration. Devices with a headset output shall be tested with a connected headset.

Test to be Performed

For purpose of determining test requirements, accessories may be divided into two categories: those that do not contain metallic components and those that do. For multiple accessories that do not contain metallic components, the device may be tested only with that accessory which provides the closest spacing to the body. For multiple accessories that contain metallic components, the device must be tested with each accessory that contains a unique metallic component. If multiple accessories share an identical metallic component, only the accessory that provides the closest spacing to the body must be tested. If the manufacturer provides none body-worn accessories a separation distance of 1.5 cm between the back of the device and the flat phantom is recommended. Other separation distances may be used, but they shall not exceed 2.5 cm. In these cases, the device may use body-worn accessories that provide a separation distance greater than that tested for the device provided however that the accessory contains no metallic components.

For devices with retractable antenna the SAR test shall be performed with the antenna fully extended and fully retracted. Other factors that may affect the exposure shall also be tested. For example, optional antennas or optional battery packs which may significantly change the volume, lengths, flip open/closed, etc. of the device, or any other accessories which might have the potential to considerably increase the peak spatial-average SAR value.

6.3. System Check

The purpose of the system check is to verify that the system operates within its specifications. System check is performed within 24 hours prior to compliance testing for each liquid type and frequency band. The system check result is verified to be within $\pm 10\%$ of the reference dipole source as measured during calibration of the dipole.

Phantom Set-Up

A flat phantom is used with the same tissue-equivalent liquid that will be used during compliance testing. The dipole feed point is placed at the centre of the flat phantom and the dipole arms are aligned with the major axis.

Standard Source

A reference dipole source is used to irradiate the phantom. The dipole is placed under the bottom of the phantom and centred with its axis parallel to the longest dimension of the phantom. A low loss spacer is used to establish the correct distance between the top surface of the dipole and the bottom surface of the phantom. For frequencies below 1 GHz, a spacing of 15 mm is used. For frequencies above 1 GHz, a spacing of 10 mm is used. The dipole has a return loss of less than -20 dB at the resonant frequency.

System Check Procedure

The test set-up is as follows:

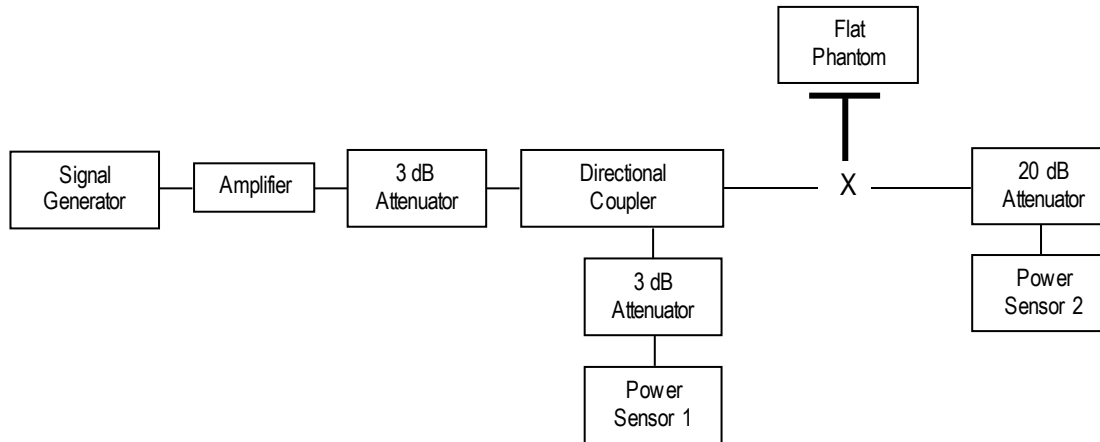

1. The cable at the output of the directional coupler is connected to the 20 dB attenuator.
2. The signal generator is adjusted until the desired input power to the dipole is measured at power sensor 2. The forward power of the directional coupler is measured with power sensor 1 and noted for step 4.
3. The cable at the output of the directional coupler is connected to the dipole source.
4. The signal generator is adjusted until power sensor 1 measures the same power as in step 2.
5. A SAR measurement is performed with the dipole source radiating.
6. During the system check test, the power measured by power sensor 1 is monitored to ensure the power does not drift.
7. At the conclusion of the SAR measurement, the SAR result is normalized to a dipole input power of 1 [W] and compared to the 1 [W] reference SAR value in the dipole calibration report. The difference between the measured SAR and the reference SAR is verified to be within $\pm 10\%$.

6.4. Procedure for assessing the peak spatial-average SAR

Step 1: Power reference measurement:

Prior to the SAR test, a local SAR measurement should be taken at a user-selected spatial reference point to monitor power variations during testing.

Step 2: Area scan

The measurement procedures for evaluating SAR associated with wireless handsets typically start with a coarse measurement grid in order to determine the approximate location of the local peak SAR values. This is referred to as the "area scan" procedure. The SAR distribution is scanned along the inside surface of typically half of the head of the phantom but at least larger than the areas projected (normal to the phantom's surface) by the handset and antenna. An example grid is given in Figure 4. The distance between the measured points and phantom surface should be less than 8 mm, and should remain constant (variation less than ± 1 mm) during the entire scan in order to determine the locations of the local peak SAR with sufficient precision. The distance between the measurement points should enable the detection of the location of local maximum with an accuracy of better than half the linear dimension of the tissue cube after interpolation. The approximate locations of the peak SARs should be determined from area scan. Since a given amplitude local peak with steep gradients may produce lower spatial-average SAR than slightly lower amplitude peaks with less steep gradients, it is necessary to evaluate the other peaks as well. However, since the spatial gradients of local SAR peaks are a function of wavelength inside the tissue simulating liquid and incident magnetic field strength, it is not necessary to evaluate peaks that are less than -2 dB of the local maximum. Two-dimensional spline algorithms [Press, et al, 1996], [Brishoual, 2001] are typically used to determine the peaks and gradients within the scanned area. If the peak is closer than one-half of the linear dimension of the 1 g or 10 g tissue cube to the scan border, the measurement area should be enlarged if possible, e.g., by tilting the probe or the phantom (see Figure 5).

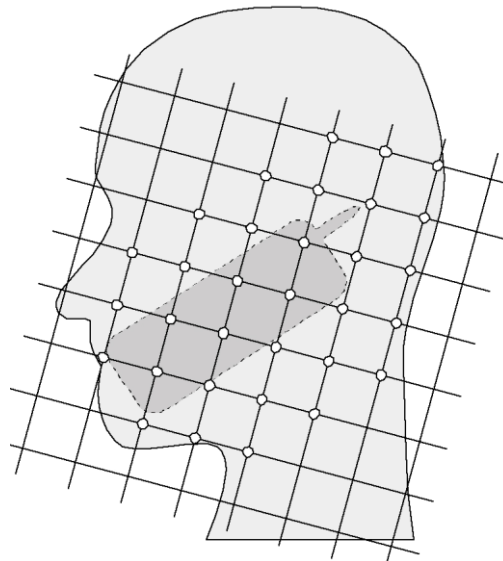

Figure 4 – Example of an area scan including the position of the handset. The scanned area (white dots) should be larger than the area projected by the handset and antenna.

The SPEAG DASY SAR system uses a mechanical sensor detection to find the phantom surface. To decrease test time, the DASY software allows the operator to choose an option where the SAR probe will reuse measurement locations from a previous identical area scan. With this option enabled, the DASY system will not use mechanical sensor detection to find the phantom surface. Locations of each measurement point of the area scan are taken at the same locations as an identical area scan if one is available. Area scans that reused location of measurement points is noted in the result plots under DASY Configuration > Sensor-Surface.

Step 3: Zoom scan

In order to assess the peak spatial SAR values averaged over a 1 g and 10 g cube, fine resolution volume scans, called "zoom scans", are performed at the peak SAR locations determined during the "area scan." The zoom scan volume should have at least 1.5 times the linear dimension of either a 1 g or a 10 g tissue cube for whichever peak spatial-average SAR is being evaluated. The peak local SAR locations that were determined in the area scan (interpolated value) should be on the centerline of the zoom scans. The centerline is

the line that is normal to the surface and in the center of the volume scan. If this is not possible, the zoom scan can be shifted but not by more than half the dimension of the 1 g or a 10 g tissue cube.

The maximum spatial-average SAR is determined by a numerical analysis of the SAR values obtained in the volume of the zoom scan, whereby interpolation (between measured points) and extrapolation (between surface and closest measured points) routines should be applied. A 3-D-spline algorithm [Press, et al, 1996], [Kreyszig, 1983], [Brishoual, 2001] can be used for interpolation and a trapezoidal algorithm for the integration (averaging). Scan resolutions of larger than 2 mm can be used provided the uncertainty is evaluated according to E (see E.5).

In some areas of the phantom, such as the jaw and upper head region, the angle of the probe with respect to the line normal to the surface might become large, e.g., at angles larger than $\pm 30^\circ$ (see Figure 5), which may increase the boundary effect to an unacceptable level. In these cases, a change in the orientation of the probe and/or the phantom is recommended during the zoom scan so that the angle between the probe housing tube and the line normal to the surface is significantly reduced ($<30^\circ$).

Step 4: Power reference measurement

The local SAR should be measured at exactly the same location as in Step 1. The absolute value of the measurement drift (the difference between the SAR measured in Step 4 and Step 1) should be recorded in the uncertainty budget. It is recommended that the drift be kept within $\pm 5\%$. If this is not possible, even with repeat testing, additional information may be used to demonstrate the power stability during the test. Power reference measurements can be taken after each zoom scan, if more than one zoom scan is needed. However, the drift should always be referred to the initial state with fully charged battery.

6.5. Determination of the largest peak spatial-average SAR

In order to determine the largest value of the peak spatial-average SAR of a handset, all device positions, configurations and operational modes should be tested for each frequency band according to steps 1 to 3 below.

Step 1: The tests of 6.4 should be conducted at the channel that is closest to the center of the transmit frequency band (f_c) for:

- a) All device positions (cheek and tilt, for both left and right sides of the SAM phantom,
- b) All configurations for each device position in (a), e.g. antenna extended and retracted, and
- c) All operational modes for each device position in (a) and configuration in (b) in each frequency band, e.g. analog and digital.

If more than three frequencies need to be tested, (i.e., $N_c > 3$), then all frequencies, configurations and modes must be tested for all of the above positions.

Step 2: For the condition providing highest spatial peak SAR determined in Step 1 conduct all tests of 6.4 at all other test frequencies, e.g. lowest and highest frequencies. In addition, for all other conditions (device position, configuration and operational mode) where the spatial peak SAR value determined in Step 1 is within 3dB of the applicable SAR limit, it is recommended that all other test frequencies should be tested as well.

Step 3: Examine all data to determine the largest value of the peak spatial-average SAR found in Steps 1 to 2.

6.6. SAR Scaling Using the Tune-Up Scaling Factor

Conducted output power is tested to check if the EUT is transmitting at the maximum power allowed according to the declared maximum power including tune-up power tolerances. When the conducted output power is less than the maximum output power including tolerance, the measured SAR values are scaled up to the maximum output power including tolerance to ensure all production units are within SAR limits.

The tune-up power scaling factor is a multiplicative factor. The tune-up power scaling factor is calculated as:

$$10^{[(\text{Maximum Output Power Including Tolerance} - \text{Measured Conducted Output Power}) / 10]}$$

Where

Maximum Output Power Including Tolerance: dBm

Measured Conducted Output Power: dBm

Example SAR scaling calculation:

Measured Conducted Output Power (dBm)	Maximum Output Power Including Tolerance (dBm)	Tune-Up Power Scaling Factor	Measured 1g SAR (W/kg)	Scaled/Reported SAR value (W/kg)
32.0	32.5	1.12	1.0	1.12

7. The Measurement System

7.1. Robot system specification

The SAR measurement system being used is the SPEAG DASY52 system, which consists of a Stäubli T X90XL 6-axis robot arm and CS8c controller, SPEAG SAR Probe, Data Acquisition Electronics, and SAM Twin Phantom. The robot is used to articulate the probe to programmed positions inside the phantom to obtain the SAR readings from the EUT.

The system is controlled remotely from a PC, which contains the software to control the robot and data acquisition equipment. The software also displays the data obtained from test scans.

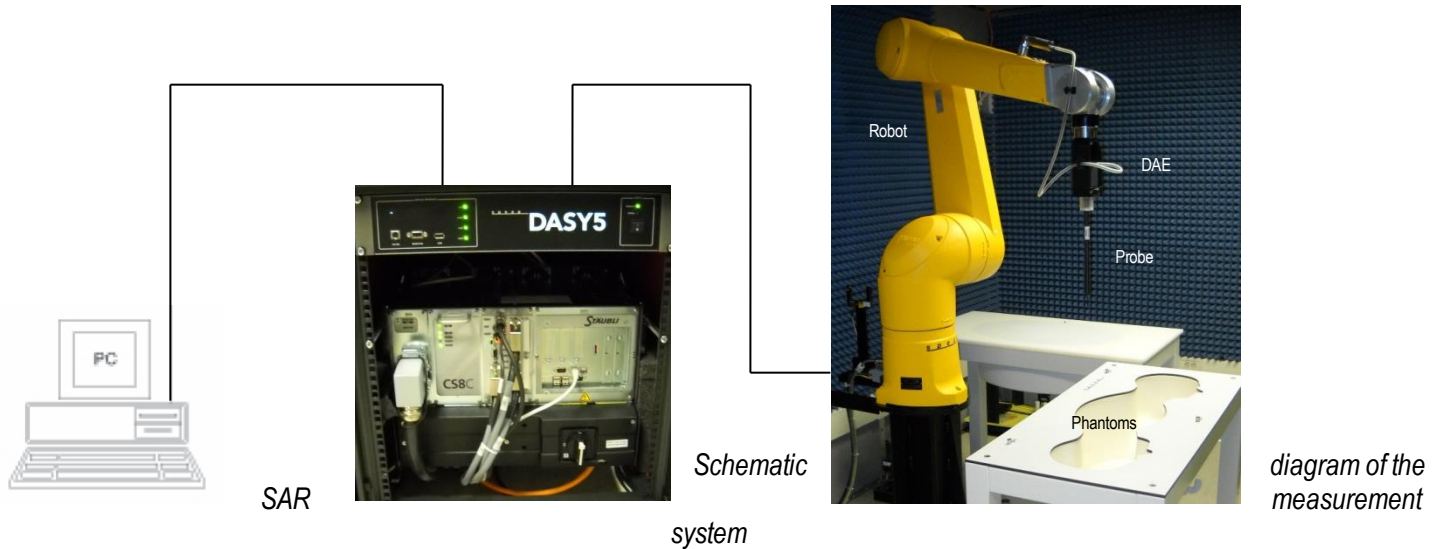

In operation, the system first does an area (2D) scan at a fixed depth within the liquid from the inside wall of the phantom. When the maximum SAR point has been found, the system will then carry out a 3D scan centered at that point to determine volume averaged SAR level.

7.2. Isotropic E-Field Probe for Dosimetry Measurements

The probes are constructed using three orthogonal dipole sensors arranged on an interlocking, triangular prism core. The probes have built-in shielding against static charges and are contained within a PEEK cylindrical enclosure material at the tip. Probe calibration is described in the probe's calibration certificate.

7.3. Data Acquisition Electronics

The DAE contains a signal amplifier, multiplexer, 16bit A/D converter and control logic. It uses an optical link for communication with the DASY5 system. The DAE has a dynamic range of -100 to 300 mV. It also contains a two-step probe touch detector for mechanical surface detection and emergency robot stop.

7.4. Phantoms

The Twin SAM V4.0 Phantom is designed to specifications defined in IEEE 1528 and IEC/EN 62209-1. It enables the dosimetry evaluation of left and right hand phone usage as well as body mounted usage at the flat phantom region. The material shell thickness is 2mm +/- 0.2 mm at the flat section and 6mm +/- 0.2 mm at the ear reference point. The relative permittivity is 3.5 +/- 0.5 and the loss tangent is ≤ 0.05 for frequencies ≤ 6 GHz.

Additionally, the Oval Flat ELI V4.0 Phantom is designed to specification defined in IEEE 1528 and IEC/EN 62209-2. It enables the dosimetry evaluation of body mounted usage. The material thickness is 2mm +/- 0.2 mm. For frequencies ≤ 6 GHz, the relative permittivity is 4 +/- 1 and the loss tangent is ≤ 0.05 . The bottom plate is 600 x 400 mm elliptical shape with a depth of 190 mm.

7.5. Interpolation and Extrapolation schemes

The interpolation, extrapolation and maximum search routines are all based on the modified Quadratic Shepard's method. The interpolation scheme combines a least-square fitted function method and a weighted average method which are the two basic types of computational interpolation and approximation. The routines construct a once-continuously differentiable function that interpolates the measurement values.

8. Uncertainty Assessment

The uncertainty budget is included as required by Industry Canada RSS-102, and as applicable for the FCC when the highest measured SAR in a band is $\geq 1.5 \text{ W/kg}$ per KDB 865664 section 2.8.2.

8.1. Measurement Uncertainty Budget According to IEEE 1528:2013

The uncertainty values for components specified were evaluated according to the procedures of IEEE 1528-2013, NIST 1297 1994 edition and ISO Guide to the Expression of Uncertainty in Measurements (GUM).

a	b	c	d	$e = f(d,k)$	f	g	$h = c \times f / e$	$i = c \times f / e$	k
Uncertainty Component	Sec.	Tol. ($\pm \%$)	Prob. Dist.	Div.	c_i (1-g)	c_i (10-g)	1-g u_i ($\pm \%$)	10-g u_i ($\pm \%$)	v_i
Measurement System									
Probe Calibration	E2.1	6.55	N	1	1	1	6.55	6.55	∞
Axial Isotropy	E2.2	4.7	R	$\sqrt{3}$	0.7	0.7	1.9	1.9	∞
Hemispherical Isotropy	E2.2	9.6	R	$\sqrt{3}$	0.7	0.7	3.9	3.9	∞
Boundary Effect	E2.3	2	R	$\sqrt{3}$	1	1	1.2	1.2	∞
Linearity	E2.4	4.7	R	$\sqrt{3}$	1	1	2.7	2.7	∞
System Detection Limits	E2.4	1	R	$\sqrt{3}$	1	1	0.6	0.6	∞
Probe Modulation Response	E2.5	2.4	R	$\sqrt{3}$	1	1	1.4	1.4	∞
Readout Electronics	E2.6	0.3	N	1	1	1	0.3	0.3	∞
Response Time	E2.7	0.8	R	$\sqrt{3}$	1	1	0.5	0.5	∞
Integration Time	E2.8	2.6	R	$\sqrt{3}$	1	1	1.5	1.5	∞
RF Ambient Noise	E6.1	3	R	$\sqrt{3}$	1	1	1.7	1.7	∞
RF Ambient Reflections	E6.1	3	R	$\sqrt{3}$	1	1	1.7	1.7	∞
Probe Positioner Mechanical Tolerance	E6.2	0.8	R	$\sqrt{3}$	1	1	0.5	0.5	∞
Probe Positioning with respect to Phantom Shell	E6.3	6.7	R	$\sqrt{3}$	1	1	3.9	3.9	∞
Extrapolation, interpolation and Integration Algorithms for Max. SAR Evaluation	E5.2	4	R	$\sqrt{3}$	1	1	2.3	2.3	∞
Test sample Related									
Test Sample Positioning	E4.2	2.9	N	1	1	1	2.9	2.9	145
Device Holder Uncertainty	E4.1	3.6	N	1	1	1	3.6	3.6	5
Output Power Variation - SAR drift measurement	E2.9	5	R	$\sqrt{3}$	1	1	2.9	2.9	∞
SAR Power Scaling	E.6.5	0	R	$\sqrt{3}$	1	1	0.0	0.0	∞
Phantom and Tissue Parameters									
Phantom Uncertainty (shape and thickness tolerances)	E3.1	6.6	R	$\sqrt{3}$	1	1	3.8	3.8	∞
Uncertainty in SAR Correction	E.3.2	1.9	R	$\sqrt{3}$	1	0.84	1.9	1.6	∞
Liquid Conductivity Target - tolerance	E3.3	2.5	R	$\sqrt{3}$	0.78	0.71	2.0	1.8	∞
Liquid Permittivity Target tolerance	E3.3	2.5	R	$\sqrt{3}$	0.26	0.26	0.7	0.7	∞
Liquid Conductivity - Temp uncertainty	E3.4	3.4	N	$\sqrt{3}$	0.78	0.71	2.7	2.4	∞
Liquid Permittivity - Temp uncertainty	E3.4	0.4	N	$\sqrt{3}$	0.23	0.26	0.1	0.1	∞
Combined Standard Uncertainty			RSS				12.7	12.6	748
Expanded Uncertainty (95% CONFIDENCE INTERVAL)			$k=2.00705$				25.4	25.2	

8.2. Measurement Uncertainty Budget According to EN 62209-2

A measurement uncertainty assessment has been undertaken following guidance given in IEC/EN-62209-2. Some of the uncertainty contributions are site-specific and, for these, CETECOM, Inc. has assessed the uncertainty contributions arising from local environmental and procedural factors. The resultant uncertainty budget, following the assessment template given IEC/EN-62209-2 is shown below:

Uncertainty Component	Sec.	TOL. (± %)	Prob. Dist.	Div.	c_i (1-g)	c_i (10-g)	1-g u_i (±%)	10-g u_i (±%)	v_i
Measurement System									
Probe Calibration	7.2.2.1	6.55	N	1	1	1	6.55	6.55	∞
Axial Isotropy	7.2.2.2	4.7	R	√3	0.7	0.7	1.9	1.9	∞
Hemispherical Isotropy	7.2.2.2	9.6	R	√3	0.7	0.7	3.9	3.9	∞
Boundary Effect	7.2.2.6	2.0	R	√3	1	1	1.2	1.2	∞
Linearity	7.2.2.3	4.7	R	√3	1	1	2.7	2.7	∞
Probe Modulation Response	7.2.2.4	2.4	R	√3	1	1	1.4	1.4	∞
System Detection Limits	7.2.2.5	1.0	R	√3	1	1	0.6	0.6	∞
Readout Electronics	7.2.2.7	0.3	N	1	1	1	0.3	0.3	∞
Response Time	7.2.2.8	0.8	R	√3	1	1	0.5	0.5	∞
Integration Time	7.2.2.9	2.6	R	√3	1	1	1.5	1.5	∞
RF Ambient Noise	7.2.4.5	3.0	R	√3	1	1	1.7	1.7	∞
RF Ambient Reflections	7.2.4.5	3.0	R	√3	1	1	1.7	1.7	∞
Probe Positioner Mechanical Tolerance	7.2.3.1	0.8	R	√3	1	1	0.5	0.5	∞
Probe Positioning with respect to Phantom Shell	7.2.3.3	6.7	R	√3	1	1	3.9	3.9	∞
Post Processing	7.2.5	4.0	R	√3	1	1	2.3	2.3	∞
Test sample Related									
Test Sample Positioning	7.2.3.4.3	2.9	N	1	1	1	2.9	2.9	145
Device Holder Uncertainty	7.2.3.4.2	3.6	N	1	1	1	3.6	3.6	5
Power Scaling	L3	0	R	√3	1	1	0.0	0.0	∞
Output Power Variation - SAR drift measurement	7.2.2.10	5.0	R	√3	1	1	2.9	2.9	∞
Phantom and Tissue Parameters									
Phantom Uncertainty (shape and thickness tolerances)	7.2.3.2	7.9	R	√3	1	1	4.6	4.6	∞
Algorithm for correcting SAR for deviations in permittivity and conductivity	7.2.4.3	1.9	R	√3	1	0.84	1.1	0.9	∞
Liquid Conductivity - measurement uncertainty	7.2.4.3	2.5	R	√3	0.78	0.71	1.1	1.0	∞
Liquid Permittivity - measurement uncertainty	7.2.4.3	2.5	R	√3	0.26	0.26	0.3	0.4	∞
Temperature Uncertainty – Conductivity	7.2.4.4	3.4	R	√3	0.78	0.71	1.5	1.4	∞
Temperature Uncertainty – Permittivity	7.2.4.4	0.4	R	√3	0.23	0.26	0.1	0.1	∞
Combined Standard Uncertainty			RSS				12.5	12.5	748
Expanded Uncertainty (95% CONFIDENCE INTERVAL)			$k=2.00705$				25.1	25.0	

8.3. Measurement Uncertainty Budget According to IEC/EN 62209-1 and IEC/EN 62209-2

A measurement uncertainty assessment has been undertaken following guidance given in IEC/EN-62209-1 and IEC/EN-62209-2. Some of the uncertainty contributions are site-specific and, for these, CETECOM, Inc. has assessed the uncertainty contributions arising from local environmental and procedural factors. The resultant uncertainty budget, following the assessment template given IEC/EN-62209-1 and IEC/EN-62209-2 is shown below:

Uncertainty Component	Sec.	TOL. (± %)	Prob. Dist.	Div.	c_i (1-g)	c_i (10-g)	1-g u_i (±%)	10-g u_i (±%)	v_i
Measurement System									
Probe Calibration	7.2.2.1	6.55	N	1	1	1	6.55	6.55	∞
Axial Isotropy	7.2.2.2	4.7	R	√3	0.7	0.7	1.9	1.9	∞
Hemispherical Isotropy	7.2.2.2	9.6	R	√3	0.7	0.7	3.9	3.9	∞
Boundary Effect	7.2.2.6	2.0	R	√3	1	1	1.2	1.2	∞
Linearity	7.2.2.3	4.7	R	√3	1	1	2.7	2.7	∞
Modulation Response	7.2.2.4	2.4	R	√3	1	1	1.4	1.4	∞
System Detection Limits	7.2.2.5	1.0	R	√3	1	1	0.6	0.6	∞
Readout Electronics	7.2.2.7	0.3	N	1	1	1	0.3	0.3	∞
Response Time	7.2.2.8	0.8	R	√3	1	1	0.5	0.5	∞
Integration Time	7.2.2.9	2.6	R	√3	1	1	1.5	1.5	∞
RF Ambient Noise	7.2.4.5	3.0	R	√3	1	1	1.7	1.7	∞
RF Ambient Reflections	7.2.4.5	3.0	R	√3	1	1	1.7	1.7	∞
Probe Positioner Mechanical Tolerance	7.2.3.1	0.8	R	√3	1	1	0.5	0.5	∞
Probe Positioning with respect to Phantom Shell	7.2.3.3	6.7	R	√3	1	1	3.9	3.9	∞
Post Processing	7.2.5	4.0	R	√3	1	1	2.3	2.3	∞
Test sample Related									
Test Sample Positioning	7.2.3.4.3	2.9	N	1	1	1	2.9	2.9	145
Device Holder Uncertainty	7.2.3.4.2	3.6	N	1	1	1	3.6	3.6	5
Power Scaling	L3	0	R	√3	1	1	0.0	0.0	∞
Output Power Variation - SAR drift measurement	7.2.2.10	5.0	R	√3	1	1	2.9	2.9	∞
Phantom and Tissue Parameters									
Phantom Uncertainty (shape and thickness tolerances)	7.2.3.2	7.9	R	√3	1	1	4.6	4.6	∞
SAR Correction	7.2.4.3	1.9	R	√3	1	0.84	1.1	0.9	∞
Liquid Conductivity - measurement uncertainty	7.2.4.3	2.5	R	√3	0.78	0.71	1.1	1.0	∞
Liquid Permittivity - measurement uncertainty	7.2.4.3	2.5	R	√3	0.26	0.26	0.3	0.4	∞
Temperature Uncertainty – Conductivity	7.2.4.4	3.4	R	√3	0.78	0.71	1.5	1.4	∞
Temperature Uncertainty – Permittivity	7.2.4.4	0.4	R	√3	0.23	0.26	0.1	0.1	∞
Combined Standard Uncertainty			RSS				12.5	12.5	748
Expanded Uncertainty (95% CONFIDENCE INTERVAL)			$k=2.00705$				25.1	25.0	

9. References

1. [IEEE 1999] IEEE Std C95.1-1999: IEEE Standard for Safety Levels with Respect to Human Exposure to Radio Frequency Electromagnetic Fields, 3 kHz to 300 GHz, Inst. of Electrical and Electronics Engineers, Inc., December 1998.
2. [IEEE 2013] IEEE Std 1528-2013: IEEE Recommended Practice for Determining the Peak Spatial-Average Specific Absorption Rate (SAR) in the Human Head From Wireless Communications Devices: Measurement Techniques. Inst. of Electrical and Electronics Engineers, Inc., June 2013.
3. [NIST 1994] NIST: Guidelines for Evaluating and Expressing the Uncertainty of NIST Measurement Results, Technical Note 1297 (TN1297), United States Department of Commerce Technology Administration, National Institute of Standards and Technology, September 1994.
4. [FCC 20XX] Various FCC KDB Publications,
< <http://transition.fcc.gov/oet/ea/eameasurements.html#sar> >
5. [IC 2015] Safety Code 6: Limits of Human Exposure to Radiofrequency Electromagnetic Energy in the Frequency Range from 3 kHz to 300 GHz
6. [IC 2010] RSS-102: Radio Frequency (RF) Exposure Compliance of Radiocommunication Apparatus (All Frequency Bands), Industry Canada, Issue 5, March 2015.
7. [IC 2012] Notice 2012-DRS1203: RE: APPLICABILITY OF LATEST FCC RF EXPOSURE KDB PROCEDURES (PUBLICATION DATE: OCTOBER 24, 2012) AND OTHER PROCEDURES, Industry Canada, December 2012
8. EN 62209-2:2010, Human exposure to radio frequency fields from hand-held and body-mounted wireless communication devices - Human models, instrumentation, and procedures - Part 2: Procedure to determine the specific absorption rate (SAR) for wireless communication devices used in close proximity to the human body (frequency range of 30 MHz to 6 GHz)

10. Report History

Date	Report Name	Changes to Report	Report prepared by
2/12/2018	SAR-FIOIN-002-17001	Initial Report	Joseph Pacheco