

AC  
1 / AB  
2

**NOTES:**

1. GRAPHICS MUST BE FREE OF OVERRUNS, SMEARS OR VOIDS. PRINTING TO BE PMS BLACK.
2. AFTER PRINTING, COVER PRINTED SIDE WITH UV VARNISH.
3. MUST BE UL RECOGNIZED MARKING AND LABELING SYSTEM, GUIDE NO. PGDQ2. 60°C MIN., FOR ADHESION TO AN ABS SURFACE. PRIOR APPROVAL BY WATERPIK MUST BE SECURED BEFORE ANY CHANGES TO MATERIAL, MATERIAL TYPE OR MATERIAL SOURCE OF SUPPLY.
4. SUPPLIER MUST CERTIFY MATERIAL MANUFACTURER AND FORMULATION ID.
5. MUST BE CSA ACCEPTED ADHESIVE FOR ADHESION TO AN ABS SURFACE.

AB  
1 SUPERSEDES 20023003 CHG "AA"

MATERIAL: WHITE LABEL STOCK

1	AC	AC-001	MEG	/	10-04-17
2	AB	AB-001	MEG	ESS/RDW	09-27-17
REL	AA	AA-001	BW	--/--	12/12/16
NO OF CHGS	CHG	DOC NUMBER	BY	CHECK	DATE

<b>DO NOT SCALE DRAWING</b> UNLESS OTHERWISE SPECIFIED DIMENSIONS ARE IN INCHES AND TOLERANCES AS FOLLOWS				
FRAC	.X DECIMAL	.XX DECIMAL	.XXX DECIMAL	ANGLE
± 1/16	± 0.1	± 0.01	± 0.005	± 1°0'
20023003_Label				

SCALE 2:1 & NOTED	
DRAWN B.WILLIAMS	DATE 12-12-16
CHECKED T.GRAVES	DATE 12-12-16
APPROVED R.WAGNER	DATE 12-12-16

WATER PIK, INC.	
UNLESS EXPRESSLY GRANTED IN WRITING, INFORMATION DISCLOSED HEREON IS CONFIDENTIAL AND ALL RIGHTS PATENT AND OTHERWISE ARE RESERVED BY WATER PIK, INC.	
SHEET 1 OF 1	SOLIDWORKS

<b>LABEL, AGENCY (W/C)</b>		
SIZE <b>B</b>	<b>20023003</b>	CHG <b>AC</b>

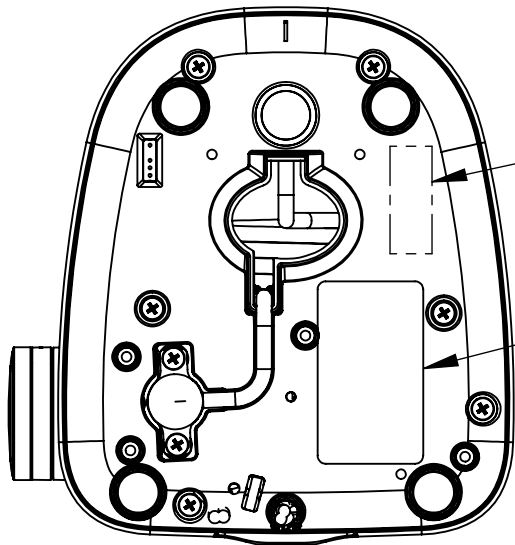
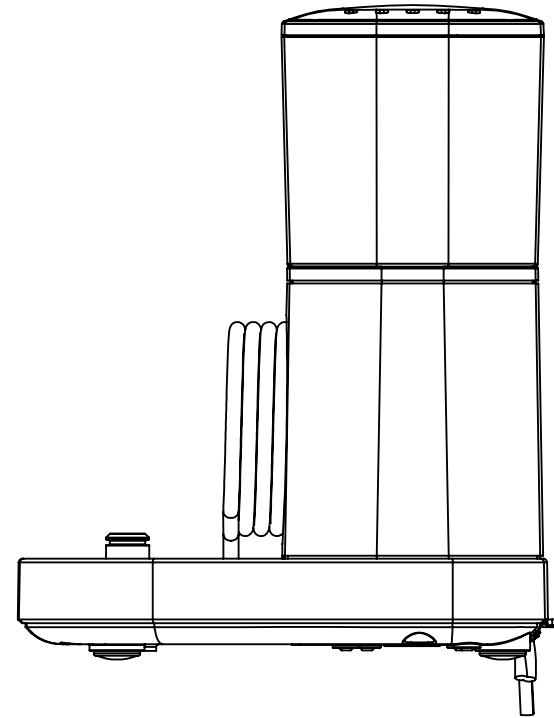
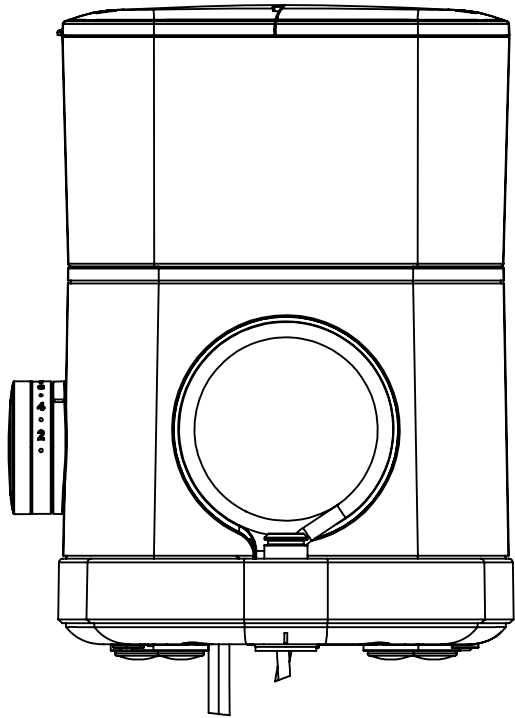

MANUFACTURING DATE CODE

AGENCY LABEL

**WATER PIK, INC.**

MODEL NUMBER: SF-02