

FCC TEST REPORT

For

ShenZhen XUNWEIJIA Technology Development LTD

Wireless microphone transmitter

Test Model: K025-TX

Additional Model: K036ATX,K026-TX

Prepared for : ShenZhen XUNWEIJIA Technology Development LTD
Address : Room1103A ,Jinhua building , Gaofeng road, Dalang,
longhua new district, Baoan, Shenzhen,China

Prepared by : Shenzhen LCS Compliance Testing Laboratory Ltd.
Address : 1/F., Xingyuan Industrial Park, Tongda Road, Bao'an Avenue, Bao'an
District, Shenzhen, Guangdong, China

Tel : (+86)755-82591330
Fax : (+86)755-82591332
Web : www.LCS-cert.com
Mail : webmaster@LCS-cert.com

Date of receipt of test sample : May 22, 2018
Number of tested samples : 1
Serial number : Prototype
Date of Test : May 24, 2018~ June 06, 2018
Date of Report : June 21, 2018

**FCC TEST REPORT
FCC CFR 47 PART 74**

Report Reference No. : **LCS180522056AEA**

Date of Issue : June 21, 2018

Testing Laboratory Name..... : **Shenzhen LCS Compliance Testing Laboratory Ltd.**

Address : 1/F., Xingyuan Industrial Park, Tongda Road, Bao'an Avenue,
Bao'an District, Shenzhen, Guangdong, China

Testing Location/ Procedure : Full application of Harmonised standards
Partial application of Harmonised standards
Other standard testing method

Applicant's Name..... : **ShenZhen XUNWEIJIA Technology Development LTD**

Address : Room1103A ,Jinhua building , Gaofeng road, Dalang,
longhua new district ,Baoan, Shenzhen ,China

Test Specification

Standard..... : FCC CFR 47 PART 74

Test Report Form No. : LCSEMC-1.0

TRF Originator : Shenzhen LCS Compliance Testing Laboratory Ltd.

Master TRF : Dated 2011-03

Shenzhen LCS Compliance Testing Laboratory Ltd. All rights reserved.

This publication may be reproduced in whole or in part for non-commercial purposes as long as the Shenzhen LCS Compliance Testing Laboratory Ltd. is acknowledged as copyright owner and source of the material. Shenzhen LCS Compliance Testing Laboratory Ltd. takes no responsibility for and will not assume liability for damages resulting from the reader's interpretation of the reproduced material due to its placement and context.

EUT Description. : Wireless microphone transmitter

Trade Mark..... : FIFINE

Model/ Type reference : K025-TX

Ratings : DC 3V by battery 2*AA

Result : **Positive**

Compiled by:

Supervised by:

Approved by:

Peter Xiao

Calvin Weng

Gavin Liang

Peter Xiao / File administrators

Calvin Weng / Technique principal

Gavin Liang/ Manager

FCC -- TEST REPORT

Test Report No. : LCS180522056AEA	<u>June 21, 2018</u> Date of issue
---	---------------------------------------

Type / Model..... : K025-TX

EUT..... : Wireless microphone transmitter

Applicant..... : ShenZhen XUNWEIJIA Technology Development LTD

Address..... : Room1103A ,Jinhua building , Gaofeng road, Dalang,
 longhua new district ,Baoan, Shenzhen ,China

Telephone..... : /

Fax..... : /

Manufacturer..... : ShenZhen XUNWEIJIA Technology Development LTD

Address..... : Room1103A ,Jinhua building , Gaofeng road, Dalang,
 longhua new district ,Baoan, Shenzhen ,China

Telephone..... : /

Fax..... : /

Factory..... : ShenZhen XUNWEIJIA Technology Development LTD

Address..... : Room1103A ,Jinhua building , Gaofeng road, Dalang,
 longhua new district ,Baoan, Shenzhen ,China

Telephone..... : /

Fax..... : /

Test Result	Positive
--------------------	-----------------

The test report merely corresponds to the test sample.
 It is not permitted to copy extracts of these test result without the written permission of the test laboratory.

Revision History

Revision	Issue Date	Revisions	Revised By
000	June 21, 2018	Initial Issue	Gavin Liang

TABLE OF CONTENTS

1. GENERAL INFORMATION	6
1.1. DESCRIPTION OF DEVICE (EUT)	6
1.2. HOST SYSTEM CONFIGURATION LIST AND DETAILS	6
1.3. EXTERNAL I/O CABLE	6
1.4. DESCRIPTION OF TEST FACILITY	6
1.5. STATEMENT OF THE MEASUREMENT UNCERTAINTY	7
1.6. MEASUREMENT UNCERTAINTY	7
1.7. DESCRIPTION OF TEST MODES	7
1.8. FREQUENCY OF CHANNELS	7
2. TEST METHODOLOGY	8
2.1. EUT CONFIGURATION	8
2.2. EUT EXERCISE	8
2.3. GENERAL TEST PROCEDURES	8
3. SYSTEM TEST CONFIGURATION.....	9
3.1. JUSTIFICATION	9
3.2. EUT EXERCISE SOFTWARE.....	9
3.3. SPECIAL ACCESSORIES	9
3.4. BLOCK DIAGRAM/SCHEMATICS.....	9
3.5. EQUIPMENT MODIFICATIONS	9
3.6. TEST SETUP.....	9
4. SUMMARY OF TEST RESULTS.....	10
5. TEST RESULT.....	11
5.1. TRANSMITTER OUTPUT POWER.....	11
5.2. OCCUPIED BANDWIDTH AND EMISSION MASK.....	13
5.3. TRANSMITTER UNWANTED EMISSIONS(RADIATED OR CONDUCTED)	16
5.4. CONDUCTED SPURIOUS EMISSION.....	21
5.5.FREQUENCY STABILITY.....	22
5.6.MODULATION CHARACTERISTICS	25
5.7.NECESSARY BANDWIDTH (BN) FOR ANALOGUE SYSTEMS.....	27
6. LIST OF MEASURING EQUIPMENTS	29
7. TEST SETUP PHOTOGRAPHS OF EUT.....	30
8. EXTERIOR PHOTOGRAPHS OF THE EUT.....	30
9. INTERIOR PHOTOGRAPHS OF THE EUT	30

1. GENERAL INFORMATION

1.1. Description of Device (EUT)

EUT	: Wireless microphone transmitter
Model Number	: K036ATX,K026-TX
Model Declaration	: PCB board, structure and internal of these model(s) are the same, So no additional models were tested
Test Model	: K025-TX
Hardware version	: XJ-038-TX
Software version	: V1.0
Power Supply	: DC 3V by battery 2*AA
Operation frequency	: 565MHz-584MHz
Modulation Type	: $\pi/4$ -DQPSK
Channel Number	: 20 channels
Channel Spacing	: 1MHz
Antenna Type	: Internal Antenna
Antenna Gain	: 0dBi(Max.)
Extreme temp. Tolerance	: -30°C to +50°C

1.2. Host System Configuration List and Details

Manufacturer	Description	Model	Serial Number	Certificate
--	--	--	--	--

1.3. External I/O Cable

I/O Port Description	Quantity	Cable
--	--	--

1.4. Description of Test Facility

FCC Registration Number. is 254912.

Industry Canada Registration Number. is 9642A-1.

ESMD Registration Number. is ARCB0108.

UL Registration Number. is 100571-492.

TUV SUD Registration Number. is SCN1081.

TUV RH Registration Number. is UA 50296516-001

NVLAP Registration Code is 600167-0

The 3m-Semi anechoic test site fulfils CISPR 16-1-4 according to ANSI C63.4:2014 and CISPR 16-1-4:2010 SVSWR requirement for radiated emission above 1GHz.

1.5. Statement of the Measurement Uncertainty

The data and results referenced in this document are true and accurate. The reader is cautioned that there may be errors within the calibration limits of the equipment and facilities. The measurement uncertainty was calculated for all measurements listed in this test report acc. To CISPR 16 – 4 “Specification for radio disturbance and immunity measuring apparatus and methods – Part 4: Uncertainty in EMC Measurements” and is documented in the LCS quality system acc. To DIN EN ISO/IEC 17025. Furthermore, component and process variability of devices similar to that tested may result in additional deviation. The manufacturer has the sole responsibility of continued compliance of the device.

1.6. Measurement Uncertainty

Test Item	Frequency Range	Uncertainty	Note
Radiation Uncertainty	9KHz~30MHz	±3.10dB	(1)
	30MHz~200MHz	±2.96dB	(1)
	200MHz~1000MHz	±3.10dB	(1)
	1GHz~26.5GHz	±3.80dB	(1)
	26.5GHz~40GHz	±3.90dB	(1)
Conduction Uncertainty	150kHz~30MHz	±1.63dB	(1)
Power disturbance	30MHz~300MHz	±1.60dB	(1)

(1). This uncertainty represents an expanded uncertainty expressed at approximately the 95% confidence level using a coverage factor of k=2.

1.7. Description of Test Modes

The EUT has been tested under operating condition.

This test was performed with EUT in X, Y, Z position and the worst case was found when EUT in X position.

Worst-case mode and channel used for 150 kHz-30 MHz power line conducted emissions was the mode and channel with the highest output power, which was determined to be (Low Channel).

Worst-case mode and channel used for 9kHz-1000 MHz radiated emissions was the mode and channel with the highest output power, that was determined to be (Low Channel).

Worst-Case data rates were utilized from preliminary testing of the Chipset, worst-case data rates used during the testing are as follows:

1.8. Frequency of Channels

Channel	Frequency(MHz)	Channel	Frequency(MHz)
00	565	10	575
01	566	11	576
02	567	12	577
03	568	13	578
04	569	14	579
05	570	15	580
06	571	16	581
07	572	17	582
08	573	18	583
09	574	19	584

2. TEST METHODOLOGY

All measurements contained in this report were conducted with ANSI C63.26-2015:American National Standard for Compliance Testing of Transmitters Used in Licensed Radio Services

The radiated testing was performed at an antenna-to-EUT distance of 3 meters. All radiated and conducted emissions measurement was performed at Shenzhen LCS Compliance Testing Laboratory Ltd.

2.1. EUT Configuration

The EUT configuration for testing is installed on RF field strength measurement to meet the Commissions requirement and operating in a manner that intends to maximize its emission characteristics in a continuous normal application.

2.2. EUT Exercise

The EUT was operated in the engineering mode to fix the TX frequency that was for the purpose of the measurements.

According to its specifications, the EUT must comply with the requirements of the Section FCC Rules Part 74.

2.3. General Test Procedures

2.3.1 Conducted Emissions

The EUT is placed on the turntable, which is 0.8 m above ground plane. According to the requirements in Section 6.2.1 of ANSI C63.4-2014 Conducted emissions from the EUT measured in the frequency range between 0.15 MHz and 30MHz using Quasi-peak and average detector modes.

2.3.2 Radiated Emissions

please refer to radated spurioes emission

3. SYSTEM TEST CONFIGURATION

3.1. Justification

The system was configured for testing in a continuous transmits condition.

3.2. EUT Exercise Software

The system was configured for testing in a continuous transmits condition;and transmission frequency by switch button control.

3.3. Special Accessories

N/A

3.4. Block Diagram/Schematics

Please refer to the related document

3.5. Equipment Modifications

Shenzhen LCS Compliance Testing Laboratory Ltd. has not done any modification on the EUT.

3.6. Test Setup

Please refer to the test setup photo.

4. SUMMARY OF TEST RESULTS

Applied Standard: FCC Part 15 Subpart C		
FCC Rules	Description of Test	Result
FCC Part 74.861(e)(1)(ii) FCC Part 2.1046	Maximum Conducted Output Power	Compliant
FCC Part 74.861 (e)(5) FCC Part 2.1049	Occupied Bandwidth	Compliant
FCC Part 74.861 (e)(4) FCC Part 2.1055	Frequency error	Compliant
FCC Part 74.861(e)(6) 2.1053	Transmitter unwanted emissions(radiated or conducted)	Compliant
FCC Part 2.1049 FCC Part 2.1047	Modulation characteristic	N/A
FCC Part 74.861 (e)(7) FCC Part 2.1049	Necessary bandwidth (BN) for analogue systems	Compliant

5. TEST RESULT

5.1. Transmitter output power

5.1.1. Measurement description:

Two traces are captured to show the difference between input- and output signals and to measure the effective output power of the device. Trace 1 shows the measurement results of the output signal and trace 2 shows the measurement results of the input signal. Marker D2 in the plots shows the difference between the input and the output signal

5.1.2. Measurement:

Measurement parameter	
Detector:	Peak (worst case) / Average (RMS)
Sweep time:	Auto / 20s
Resolution bandwidth:	> emission bandwidth
Video bandwidth:	> resolution bandwidth
Span:	> 2 times emissions bandwidth
Trace mode:	Max. hold
EUT configuration:	Peak: Unmodulated carrier RMS: Modulate the transmitter with a 2.5 kHz tone at a level 16 dB higher than that required to produce a frequency deviation of ± 75 kHz, or to produce 50% of the manufacturer's rated

5.1.3. Limits:

FCC
470 MHz to 608 MHz 250 mW (average) / 24 dBm (average)

5.1.4. Test result:

The EUT was programmed to be in continuously transmitting mode.

5.1.5. Test result

Test Mode	Channel	Frequency (MHz)	Measured Maximum Peak Power(dBm)	Measured Maximum Average Power(dBm)	Limits Average (dBm)	Verdict
π /4-DQPSK	00	565	5.549	/	24	PASS
	09	574	6.514	/		
	19	584	6.867	/		

Maximum Peak Output Power

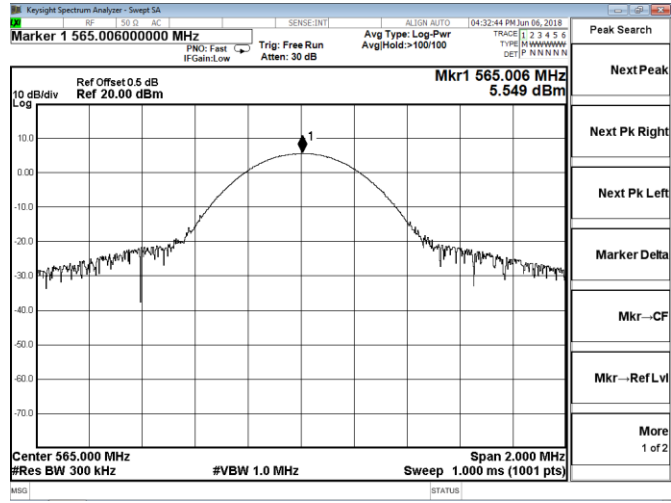

Channel 0 / 565 MHz

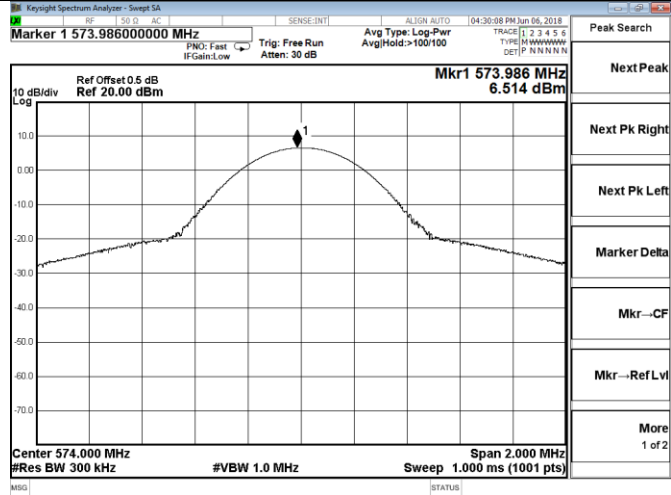

Channel 09 / 574 MHz

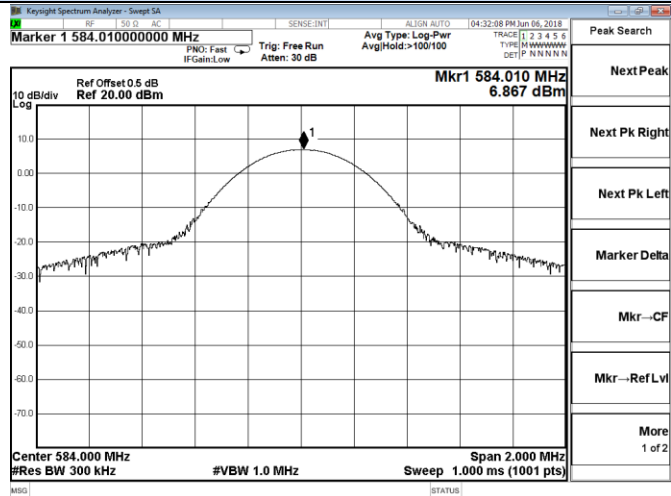

Channel 19 / 584 MHz

5.2. Occupied bandwidth and Emission Mask

5.2.1. Measurement description:

Two traces are captured to show the difference between input- and output signals and to measure the effective bandwidth of the output signal. Trace 1 shows the measurement results of the output signal and trace 2 shows the measurement results of the input signal.

5.2.2. Measurement:

Measurement parameter	
Detector:	Peak
Sweep time:	Auto
Resolution bandwidth:	1 % to 5 % of the occupied bandwidth
Video bandwidth:	3 x resolution bandwidth
Span:	2 x emission bandwidth
Trace mode:	Max. hold
Analyzer function:	99% power occupied bandwidth function
EUT:	Modulated signal with max. frequency deviation

5.2.3. Result:

Test Mode	Channel	Frequency (MHz)	99% Bandwidth (KHz)	Limits (KHz)	Verdict
π /4-DQPSK	00	565	122.29	200	PASS
	09	574	120.94		
	19	584	121.83		

99% Bandwidth

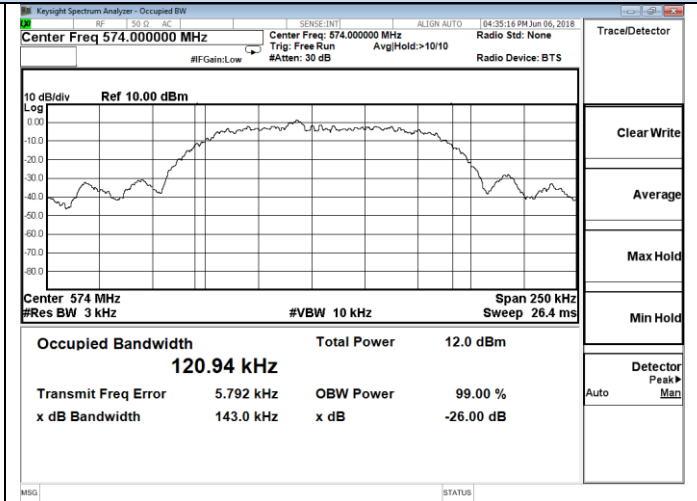
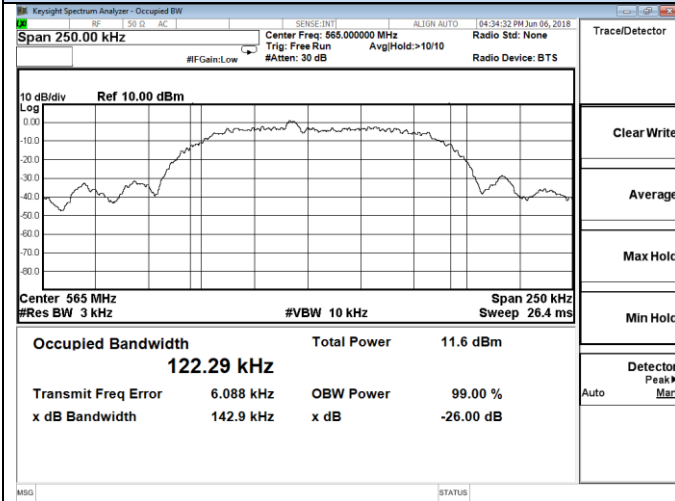

Channel 0 / 565 MHz

Channel 09 / 574 MHz

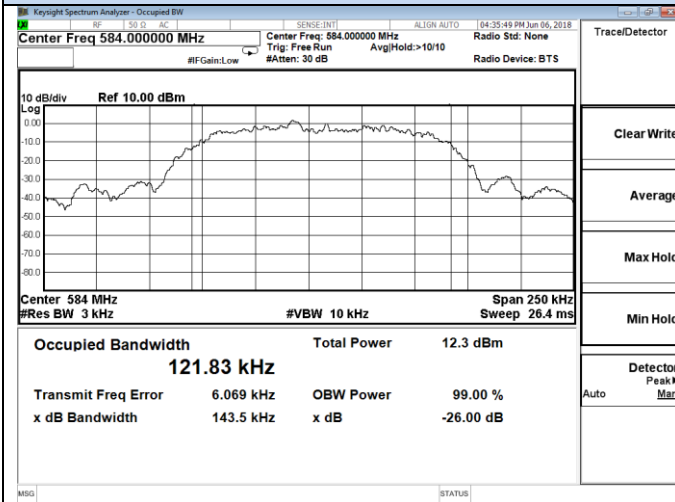

Channel 19 / 584 MHz

Spectrum mask

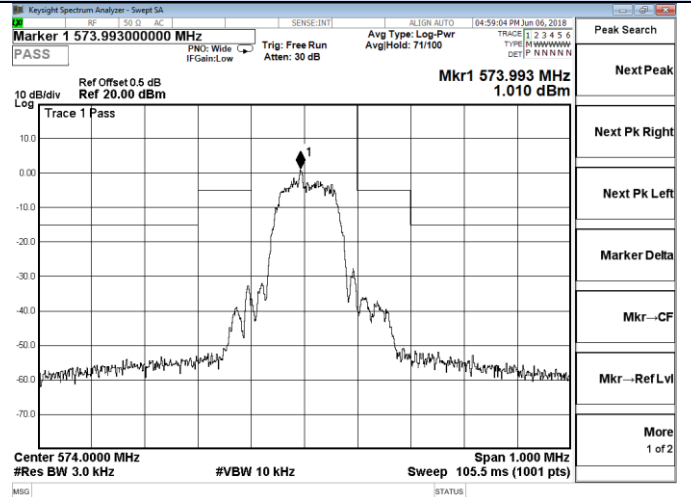
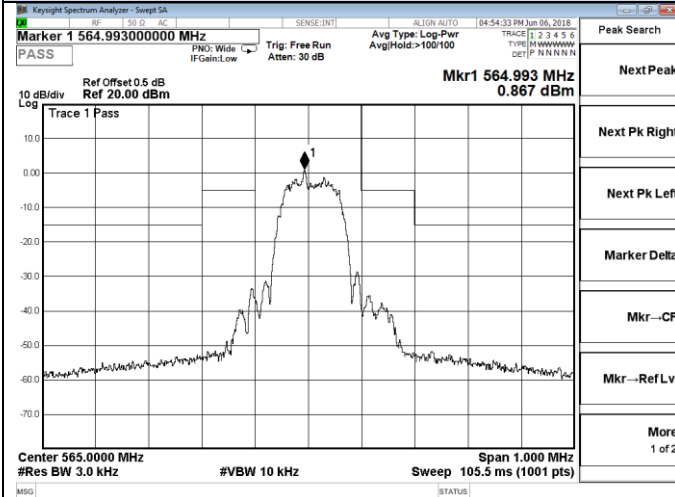

Channel 0 / 565 MHz

Channel 09 / 574 MHz

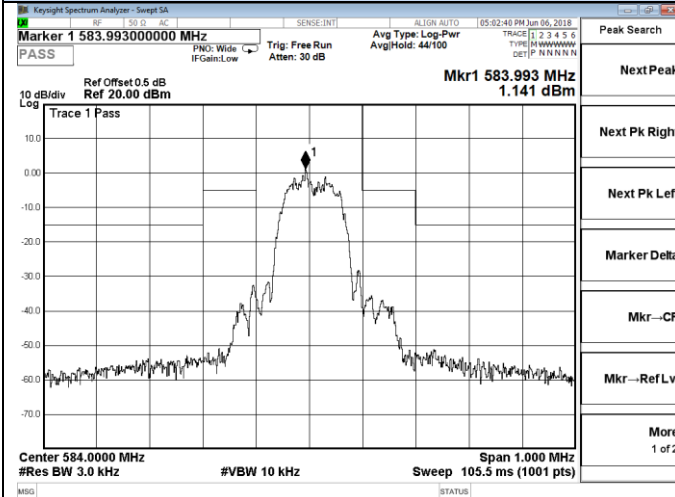

Channel 19 / 584 MHz

5.3. Transmitter unwanted emissions(radiated)

5.3.1. Measurement description:

TEST CONFIGURATION

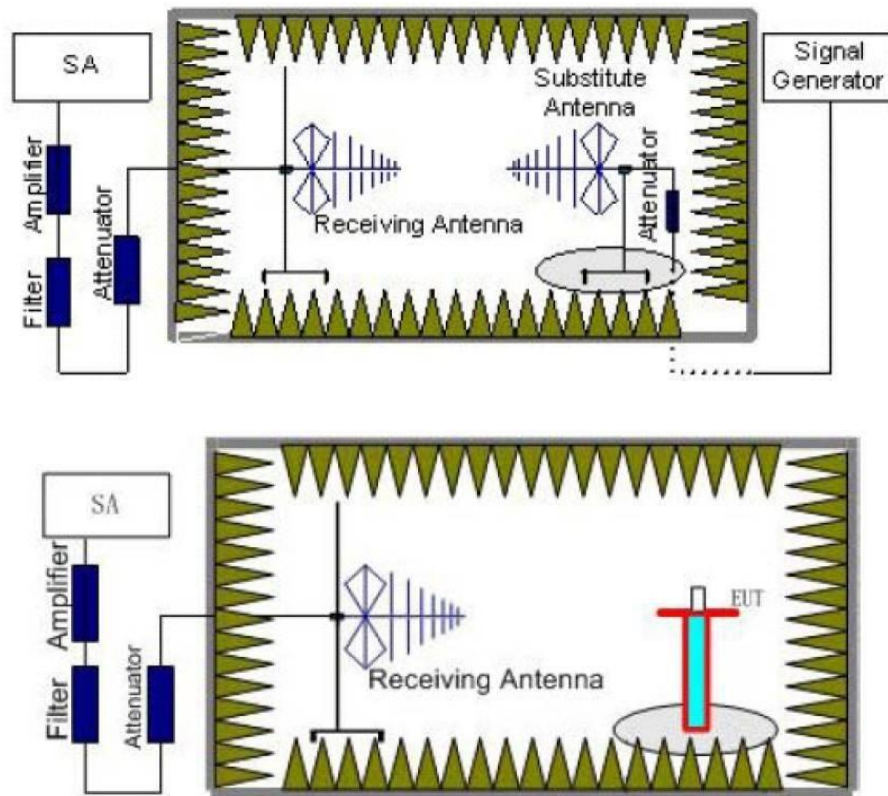

TEST PROCEDURE

1. EUT was placed on a 1.50 meter high non-conductive stand at a 3 meter test distance from the receive antenna. A receiving antenna was placed on the antenna mast 3 meters from the EUT for emission measurements. The height of receiving antenna is 1.50 m. Detected emissions were maximized at each frequency by rotating the EUT through 360° and adjusting the receiving antenna polarization. The radiated emission measurements of all transmit frequencies in three channels (High, Middle, Low) were measured with peak detector.
2. A log-periodic antenna or double-ridged waveguide horn antenna shall be substituted in place of the EUT. The log-periodic antenna will be driven by a signal generator and the level will be adjusted till the same power value on the spectrum analyzer or receiver. The level of the spurious emissions can be calculated through the level of the signal generator, cable loss, the gain of the substitution antenna and the reading of the spectrum analyzer or receiver.
3. The EUT is then put into continuously transmitting mode at its maximum power level during the test. Set Test Receiver or Spectrum RBW=1MHz, VBW=3MHz, And the maximum value of the receiver should be recorded as (P_r).
4. The EUT shall be replaced by a substitution antenna. In the chamber, an substitution antenna for the frequency band of interest is placed at the reference point of the chamber. An RF Signal source for the frequency band of interest is connected to the substitution antenna with a cable that has been constructed to not interfere with the radiation pattern of the antenna. A power (P_{Mea}) is applied to the input of the substitution antenna, and adjust

the level of the signal generator output until the value of the receiver reach the previously recorded (P_r). The power of signal source (P_{Mea}) is recorded. The test should be performed by rotating the test item and adjusting the receiving antenna polarization.

5. A amplifier should be connected to the Signal Source output port. And the cable should be connect between the Amplifier and the Substitution Antenna. The cable loss (P_{cl}), the Substitution Antenna Gain (G_a) and the Amplifier Gain (P_{Ag}) should be recorded after test.
The measurement results are obtained as described below:
 $Power(EIRP)=P_{Mea}-P_{Ag}-P_{cl}+G_a$
6. This value is EIRP since the measurement is calibrated using an antenna of known gain (2.15 dBi) and known input power.
7. ERP can be calculated from EIRP by subtracting the gain of the dipole, $ERP = EIRP - 2.15dBi$.
8. In order to make sure test results more clearly,we set frequency range and sweep time for difference frequency range as follows table:

TEST LIMITS

FCC & IC (according to ETSI EN 300 422-1 V2.1.2 (2017-01))			
State	Max. spurious level		
	47 MHz to 74 MHz 87.5 MHz to 118 MHz 174 MHz to 230 MHz	Other frequencies ≤ 1000 MHz	All frequencies > 1000 MHz
Operating	4.0 nW	250 nW	1.00 μW
Standby	2.0 nW	2.0 nW	20.0 nW

FCC & IC	
The mean power of emissions shall be attenuated below the mean output power of the transmitter in accordance with the following schedule:	
On any frequency removed from the operating frequency by more than 50 percent up to and including 100 percent of the	25 dB
On any frequency removed from the operating frequency by more than 100 percent up to and including 250 percent of	35 dB
On any frequency removed from the operating frequency by more than 250 percent of the authorized bandwidth: at least	$43 + 10\log_{10}$ (mean output power in watts) dB

5.3.2. Results for Radiated Emissions

Channel 0 / 565 MHz

Vertical/ Horizontal

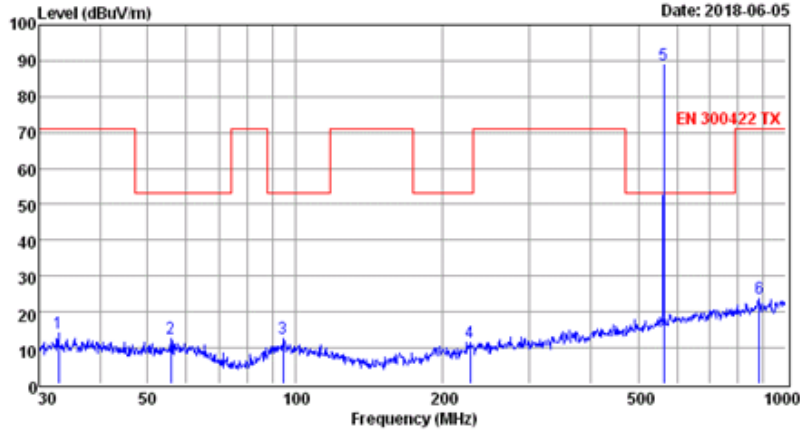

	Freq	Reading	CabLos	Antfac	Measured	Limit	Over	Remark
	MHz	dBuV	dB	dB/m	dBuV/m	dBuV/m	dB	
1	32.86	1.30	0.37	12.31	13.98	71.00	-57.02	QP
2	55.80	-0.96	0.47	12.97	12.48	53.00	-40.52	QP
3	94.43	-0.53	0.58	12.73	12.78	53.00	-40.22	QP
4	226.89	-1.01	0.89	11.51	11.39	53.00	-41.61	QP
5	564.64	69.50	1.47	17.79	88.76	53.00	35.76	Peak
6	884.50	0.88	1.87	20.93	23.68	71.00	-47.32	QP

Note: 1. All readings are Quasi-peak values.
 2. Measured= Reading + Antenna Factor + Cable Loss
 3. The emission that at 20db blow the official limit are not reported

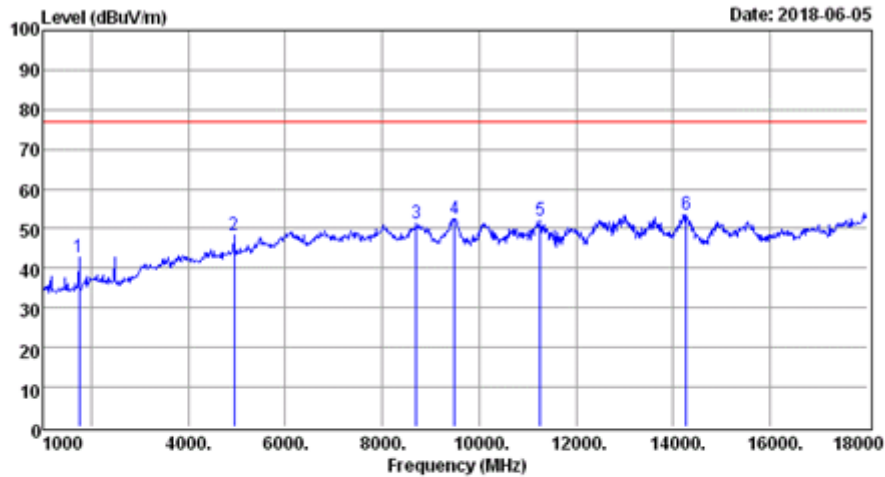

	Freq	Reading	CabLos	Antfac	Measured	Limit	Over	Remark
	MHz	dBuV	dB	dB/m	dBuV/m	dBuV/m	dB	
1	1748.00	48.96	4.45	26.42	42.82	77.00	-34.18	Peak
2	4944.00	43.47	7.77	33.66	48.50	77.00	-28.50	Peak
3	8701.00	39.56	9.74	37.58	51.28	77.00	-25.72	Peak
4	9500.00	40.07	9.95	37.96	52.56	77.00	-24.44	Peak
5	11251.00	40.05	10.18	37.70	52.14	77.00	-24.86	Peak
6	14260.00	38.96	10.36	39.94	53.38	77.00	-23.62	Peak

Note: 1. All readings are Quasi-peak values.
 2. Measured= Reading + Antenna Factor + Cable Loss
 3. The emission that at 20db blow the official limit are not reported

Channel 09 /574 MHz

Vertical/ Horizontal

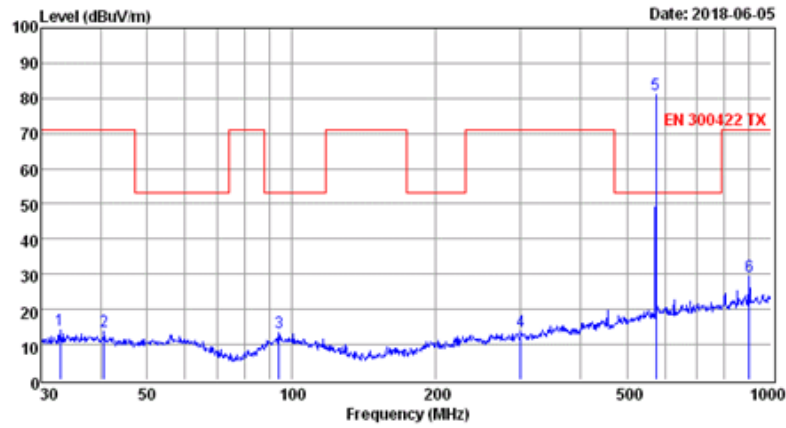

	Freq MHz	Reading dBuV	CabLos dB	Antfac dB/m	Measured dBuV/m	Limit dBuV/m	Over dB	Remark
1	32.86	1.30	0.37	12.31	13.98	71.00	-57.02	QP
2	40.56	-0.45	0.50	13.58	13.63	71.00	-57.37	QP
3	94.10	0.04	0.58	12.67	13.29	53.00	-39.71	QP
4	300.37	-0.61	1.13	13.06	13.58	71.00	-57.42	QP
5	574.63	61.69	1.49	17.98	81.16	53.00	28.16	Peak
6	900.15	6.58	1.88	21.09	29.55	71.00	-41.45	QP

- Note: 1. All readings are Quasi-peak values.
 2. Measured= Reading + Antenna Factor + Cable Loss
 3. The emission that at 20db below the official limit are not reported

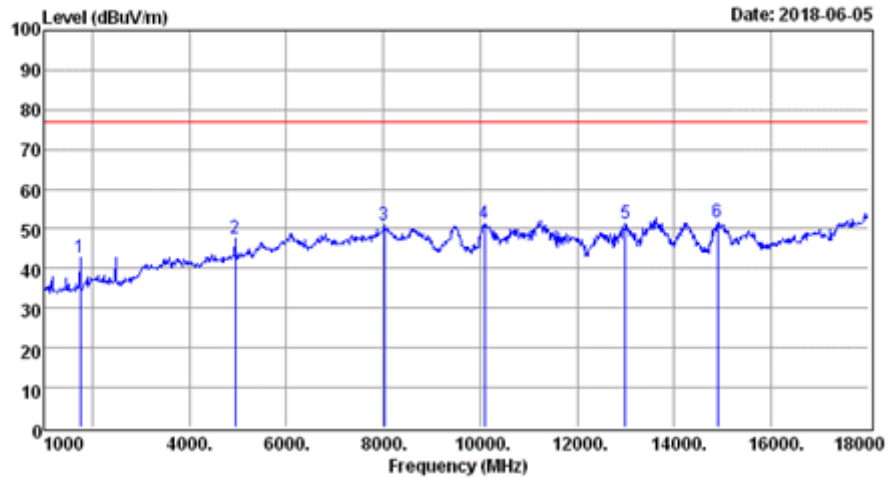

	Freq MHz	Reading dBuV	CabLos dB	Antfac dB/m	Measured dBuV/m	Limit dBuV/m	Over dB	Remark
1	1748.00	75.38	4.45	0.00	42.82	77.00	-34.18	Peak
2	4944.00	76.13	7.77	0.00	47.50	77.00	-29.50	Peak
3	8021.00	75.79	9.60	0.00	50.82	77.00	-26.18	Peak
4	10078.00	76.55	10.10	0.00	51.33	77.00	-25.67	Peak
5	12985.00	76.01	10.28	0.00	51.34	77.00	-25.66	Peak
6	14889.00	77.43	10.39	0.00	51.72	77.00	-25.28	Peak

- Note: 1. All readings are Quasi-peak values.
 2. Measured= Reading + Antenna Factor + Cable Loss
 3. The emission that at 20db below the official limit are not reported

Channel 19 / 584 MHz

Vertical/ Horizontal

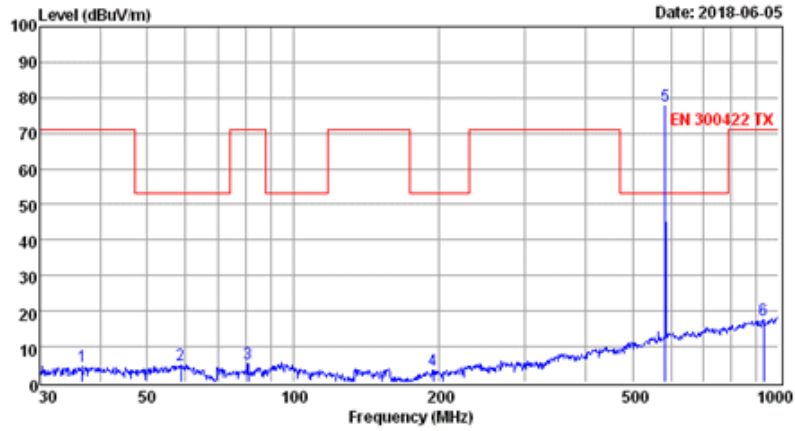

	Freq	Reading	CabLos	Antfac	Measured	Limit	Over	Remark
	MHz	dBuV	dB	dB/m	dBuV/m	dBuV/m	dB	
1	36.77	-8.84	0.41	12.75	4.32	71.00	-66.68	QP
2	58.61	-8.35	0.49	12.78	4.92	53.00	-48.08	QP
3	80.64	-4.13	0.65	8.77	5.29	71.00	-65.71	QP
4	194.45	-7.93	0.76	10.56	3.39	53.00	-49.61	QP
5	584.79	57.98	1.50	18.17	77.65	53.00	24.65	Peak
6	932.27	-5.80	1.98	21.30	17.48	71.00	-53.52	QP

Note: 1. All readings are Quasi-peak values.
 2. Measured= Reading + Antenna Factor + Cable Loss
 3. The emission that ate 20db blow the official limit are not reported

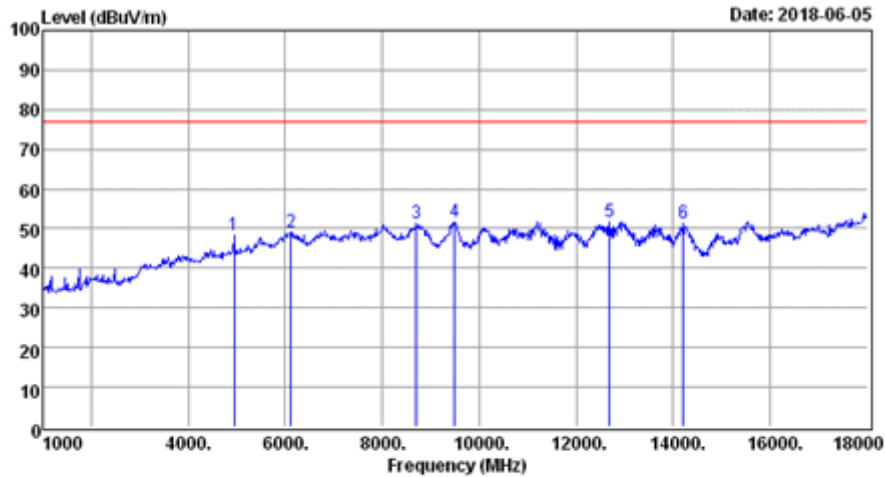

	Freq	Reading	CabLos	Antfac	Measured	Limit	Over	Remark
	MHz	dBuV	dB	dB/m	dBuV/m	dBuV/m	dB	
1	4944.00	43.47	7.77	33.66	48.50	77.00	-28.50	Peak
2	6117.00	40.52	8.94	36.36	49.04	77.00	-27.96	Peak
3	8701.00	39.56	9.74	37.58	51.28	77.00	-25.72	Peak
4	9500.00	39.07	9.95	37.96	51.56	77.00	-25.44	Peak
5	12679.00	37.88	10.26	38.01	51.53	77.00	-25.47	Peak
6	14209.00	36.84	10.35	40.02	51.37	77.00	-25.63	Peak

Note: 1. All readings are Quasi-peak values.
 2. Measured= Reading + Antenna Factor + Cable Loss
 3. The emission that ate 20db blow the official limit are not reported

Note: All detected emissions are more than 20 dB below the limit, In addition to main frequency.

5.4. Conducted spurious emission

5.4.1. Description:

Measurement of the conducted spurious emissions in transmit mode below 30 MHz. The EUT is set to channel

6. This measurement is repeated for DSSS and OFDM modulation. If peaks are found channel 1 and channel 11 will be measured too. The measurement is performed with the data rate producing the highest output power. Both power lines, phase and neutral line, are measured. Found peaks are re-measured with average and quasi peak detection to show compliance to the limits.

5.4.2. Measurement:

Measurement parameter	
Detector:	Peak - Quasi Peak / Average
Sweep time:	Auto
Resolution bandwidth:	F < 150 kHz: 200 Hz F > 150 kHz: 9 kHz
Video bandwidth:	F < 150 kHz: 1 kHz F > 150 kHz: 100 kHz
Span:	9 kHz to 30 MHz
Trace mode:	Max Hold

5.4.3. Limits:

FCC		
Frequency (MHz)	Quasi-Peak (dBµV/m)	Average (dBµV/m)
0.15 – 0.5	66 to 56*	56 to 46*
0.5 – 5	56	46
5 – 30.0	60	50

5.4.4. Results:

Do not apply

5.5.Frequency Stability

Test Requirement:FCC CFR 47 Part 74.e) 4)

Test Method:FCC CFR 47 Part 2.1055

Requirements:+/-50 ppm

(e) For low power auxiliary stations operating in the bands allocated for TV broadcasting, the following technical requirements apply:

(4) The frequency tolerance of the transmitter shall be 0.005 percent.

Test Procedure:

Frequency stability versus Environmental Temperature

The equipment under test was connected to an external DC power supply and the RF output was connected to a frequency counter via feed through attenuators.

The EUT was placed inside the temperature chamber. After the temperature stabilized for approximately 20 minutes, the frequency of the output signal was recorded from the counter.

Frequency Stability versus Input Voltage

At room temperature ($25 \pm 5^{\circ}\text{C}$), an external variable DC power supply was connected to the EUT. The frequency of the transmitter was measured for 115%, 100% and 85% of the nominal operating input voltage. For hand carried, battery powered equipment, reduce primary supply voltage to the battery operating end point which shall be specified by the manufacturer.

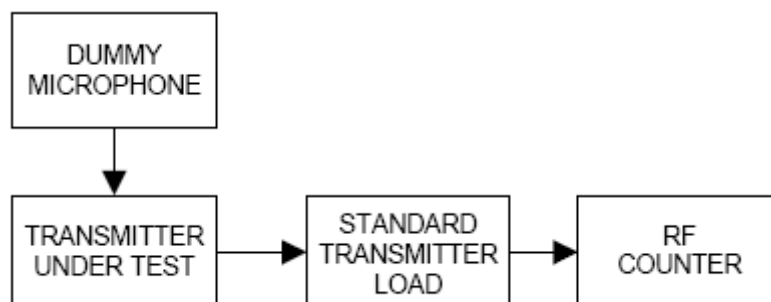

Test Result:

Assigned Frequency: 565.000 MHz,		
Environment Temperature (°C)	Power Supplied (Vdc)	Frequency Measure with Time Elapsed Total emission within +/- 28.25 kHz
50	3.0	+6.8
40	3.0	+4.8
30	3.0	+3.2
20	3.0	+1.2
10	3.0	-3.5
0	3.0	-4.2
-10	3.0	-4.8
-20	3.0	-5.8
-30	3.0	-5.9
Environment Temperature (°C)	Power Supplied (Vdc)	Frequency Measure with Time Elapsed Total emission within Max +/- 28.25 kHz
25	3.0	+2.8
25	2.7	-3.6
25	2.4	-2.2

Assigned Frequency: 574.000 MHz,		
Environment Temperature (°C)	Power Supplied (Vdc)	Frequency Measure with Time Elapsed Total emission within +/- 28.70 kHz
50	3.0	+7.1
40	3.0	+6.3
30	3.0	+4.5
20	3.0	+2.5
10	3.0	-1.6
0	3.0	-2.9
-10	3.0	-4.0
-20	3.0	-5.1
-30	3.0	-6.3
Environment Temperature (°C)	Power Supplied (Vdc)	Frequency Measure with Time Elapsed Total emission within Max +/- 28.70 kHz
25	3.0	+4.1
25	2.7	-1.8
25	2.4	-3.5

Assigned Frequency: 584.000 MHz,		
Environment Temperature (°C)	Power Supplied (Vdc)	Frequency Measure with Time Elapsed Total emission within +/- 29.20 kHz
50	3.0	+6.6
40	3.0	+4.2
30	3.0	+2.3
20	3.0	+1.4
10	3.0	-2.4
0	3.0	-3.7
-10	3.0	-4.5
-20	3.0	-4.6
-30	3.0	-5.8
Environment Temperature (°C)	Power Supplied (Vdc)	Frequency Measure with Time Elapsed Total emission within Max +/- 29.20 kHz
25	3.0	+3.9
25	2.7	-2.7
25	2.4	-4.5

Battery end point: 2.4Vdc

The results: The unit does meet the FCC requirements.

5.6.Modulation Characteristics

Test Requirement:FCC CFR 47 Part 74.e) 3)

Test Method:FCC CFR 47 Part 2.1047 & TIA/EIA 603 E 2016:Land Mobile $\pi/4$ -DQPSK or PM
Communications Equipment Measurement and Performance Standards

Requirements:

(e) For low power auxiliary stations operating in the bands allocated for TV broadcasting, the following technical requirements apply:

(3) Any form of modulation may be used. A maximum deviation of ± 75 kHz is permitted when frequency modulation is employed.

Test Procedure:

Audio Frequency Response

The RF output of the transceiver was connected to the input of FSP 30 with FM deviation module through sufficient attenuation so as not to overload the meter or distort the reading. An audio signal generator was connected to the audio input of microphone.

The audio signal input level was adjusted to obtain 20% of the maximum rated system deviation at 1 kHz, and recorded as DEV REF . With the audio signal generator level unchanged, set the generator frequency between 100 to 5000 Hz. The transmitter deviations (DEV FREQ) were measured and the audio frequency response was calculated as $20\log_{10} [\text{DEV FREQ} / \text{DEV REF}]$

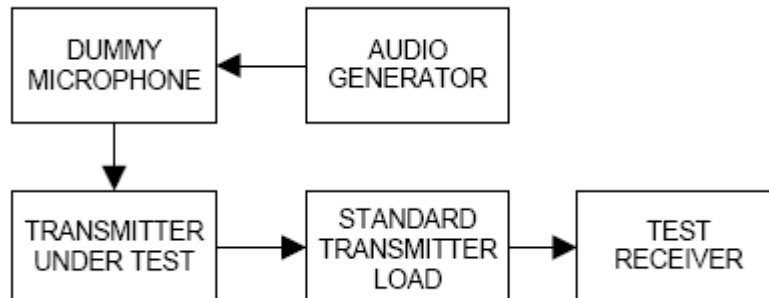

The plot(s) of Audio Frequency Response is presented hereinafter as reference.

Test Result:

Not Applicable

Modulation Limiting

- a) Adjust the transmitter per the manufacturer's procedure for full rated system deviation.
- b) Set the test receiver to measure peak positive deviation. Set the audio bandwidth for ≤ 0.25 Hz to $\geq 15,000$ Hz. Turn the de-emphasis function off.
- c) Apply a **1000 Hz** modulating signal to the transmitter from the audio frequency generator, and adjust the level to obtain **60% of full rated system deviation**.
- d) Increase the level from the audio frequency generator by 20 dB in one step (rise time between the 10% and 90% points shall be 0.1 second maximum).
- e) Measure both the instantaneous and steady-state deviation at and after the time of increasing the audio input level.

With the level from the audio frequency generator held constant at the level obtained in step e), slowly vary the audio frequency from 100 to 15k Hz and observe the steady-state deviation. Record the maximum deviation.

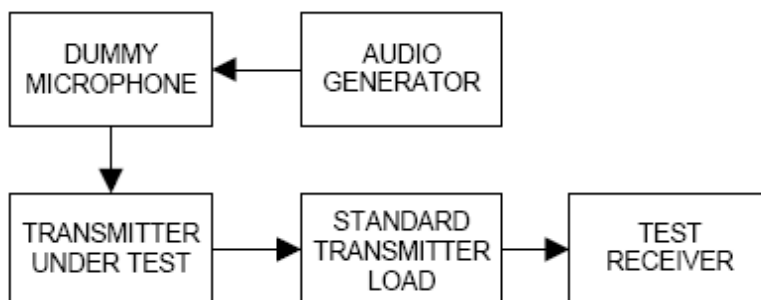

Test at five different modulating frequencies (100Hz, 300Hz, 500Hz, 1KHz, 2.5kHz, 5kHz, 10kHz, 15kHz), the output level of the audio generator was varied up to 1V and the FM deviation level was recorded.

Positive peak deviation

Test Result:

Not Applicable

5.7.Necessary bandwidth (BN) for analogue systems

5.7.1.Measurement:

Measurement parameter	
Detector:	Peak - Quasi Peak / Average
Sweep time:	Auto
Resolution bandwidth:	1 kHz
Video bandwidth:	1 kHz
Span:	Fc-1MHz to fc+1MHz(2MHz)
Trace mode:	Max Hold

5.7.2.Limits:

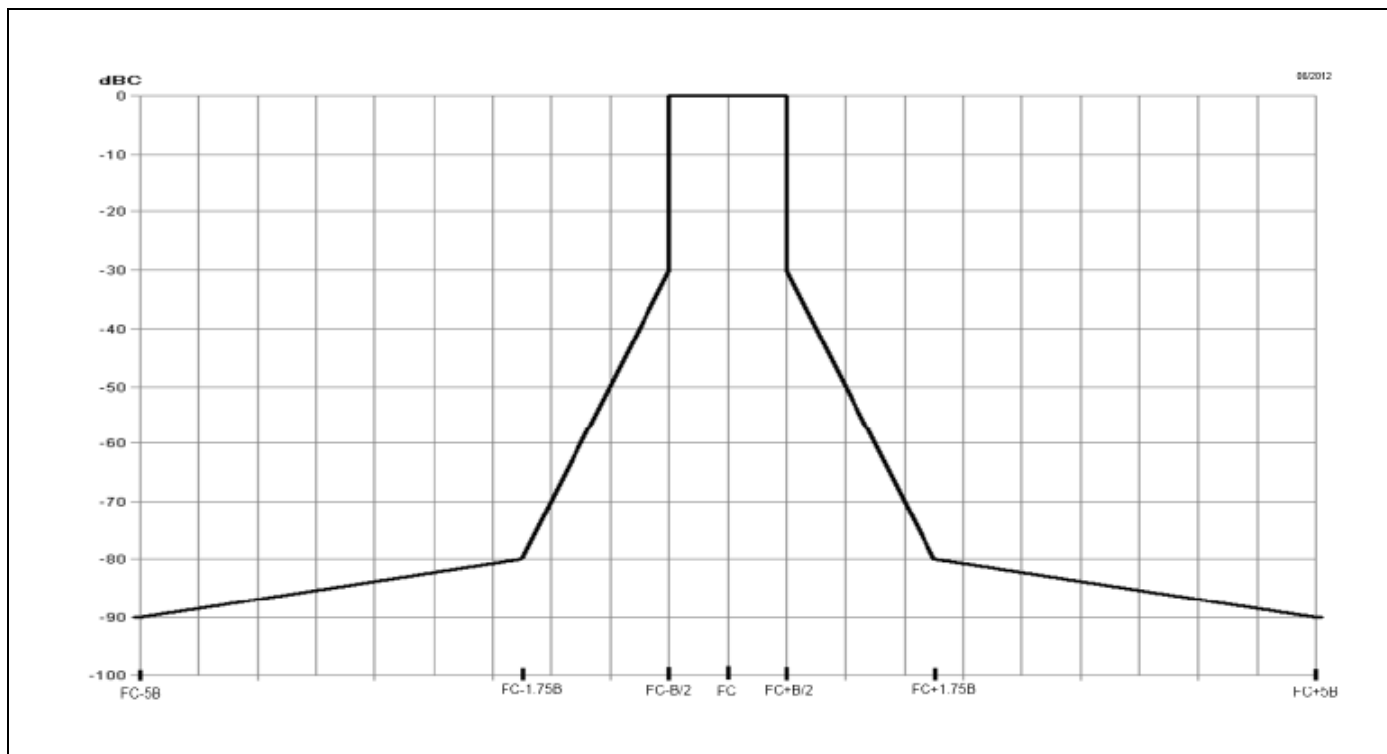

5.7.3. Results:

Necessary bandwidth

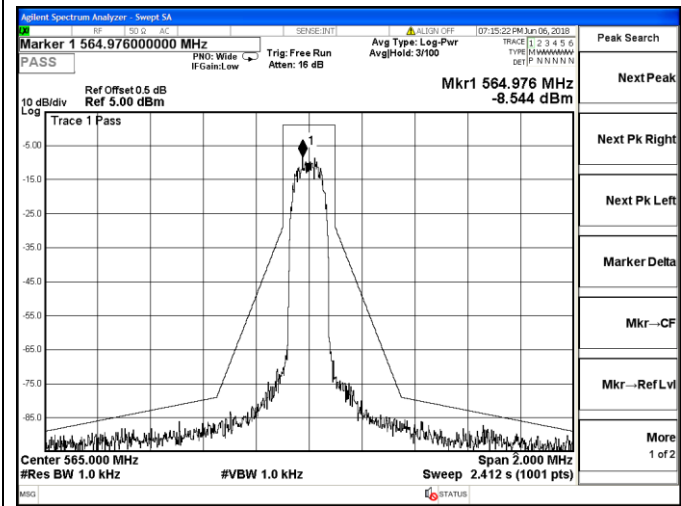

Channel 0 / 565 MHz

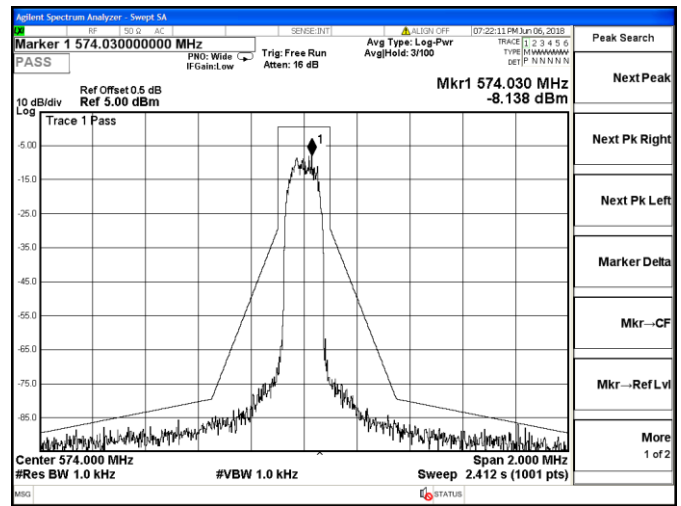

Channel 09 / 574 MHz

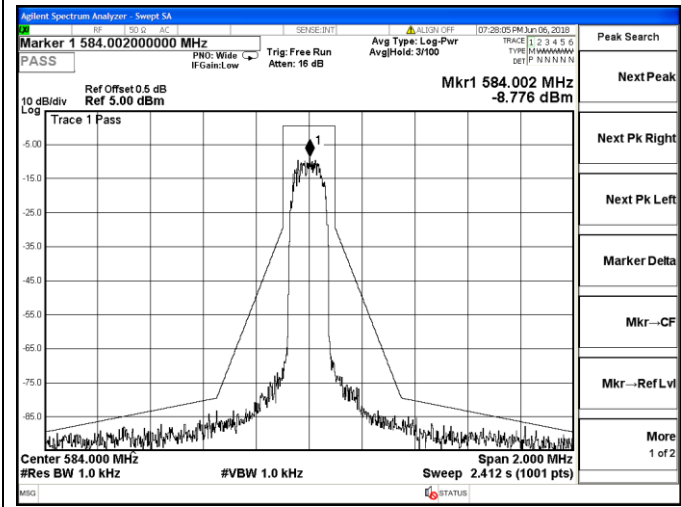

Channel 19 / 584 MHz

6. LIST OF MEASURING EQUIPMENTS

Item	Equipment	Manufacturer	Model No.	Serial No.	Last Cal.	Next Cal.
1	Power Sensor	R&S	NRV-Z81	100458	2017-06-17	2018-06-16
2	Power Sensor	R&S	NRV-Z32	10057	2017-06-17	2018-06-16
3	Power Meter	R&S	NRVS	100444	2017-06-17	2018-06-16
4	DC Filter	MPE	23872C	N/A	2017-06-17	2018-06-16
5	RF Cable	Harbour Industries	1452	N/A	2017-06-17	2018-06-16
6	SMA Connector	Harbour Industries	9625	N/A	2017-06-17	2018-06-16
7	Spectrum Analyzer	Agilent	N9020A	MY50510140	2017-10-27	2018-10-26
8	Signal analyzer	Agilent	E4448A(External mixers to 40GHz)	US44300469	2017-06-15	2018-06-14
9	RF Cable	Hubersuhne	Sucoflex104	FP2RX2	2017-06-17	2018-06-16
10	3m Semi Anechoic Chamber	SIDT FRANKONIA	SAC-3M	03CH03-HY	2017-06-17	2018-06-16
11	Amplifier	SCHAFFNER	COA9231A	18667	2017-06-17	2018-06-16
12	Amplifier	Agilent	8449B	3008A02120	2017-06-15	2018-06-14
13	Amplifier	MITEQ	AMF-6F-260400	9121372	2017-06-15	2018-06-14
14	Loop Antenna	R&S	HFH2-Z2	860004/001	2017-06-17	2018-06-16
15	By-log Antenna	SCHWARZBECK	VULB9163	9163-470	2017-06-09	2018-06-08
16	Horn Antenna	EMCO	3115	6741	2017-06-09	2018-06-08
17	Horn Antenna	SCHWARZBECK	BBHA9170	BBHA9170154	2017-06-09	2018-06-08
18	RF Cable-R03m	Jye Bao	RG142	CB021	2017-06-17	2018-06-16
19	RF Cable-HIGH	SUHNER	SUCOFLEX 106	03CH03-HY	2017-06-17	2018-06-16
20	EMI Test Receiver	R&S	ESCI	101142	2017-06-17	2018-06-16
21	Artificial Mains	R&S	ENV216	101288	2017-06-17	2018-06-16
22	EMI Test Software	AUDIX	E3	N/A	2017-06-17	2018-06-16
23	Spectrum Analyzer	R&S	FSP	100503	2017-06-17	2018-06-16

7. TEST SETUP PHOTOGRAPHS OF EUT

Please refer to separated files for Test Setup Photos of the EUT.

8. EXTERIOR PHOTOGRAPHS OF THE EUT

Please refer to separated files for External Photos of the EUT.

9. INTERIOR PHOTOGRAPHS OF THE EUT

Please refer to separated files for Internal Photos of the EUT.

-----THE END OF REPORT-----