



Wireless IP Camera User Manual

C188

For more information, please visit [https:// www.zositech.com](https://www.zositech.com)
Support Email: service@zositech.com

Terms of Use

- Please read this guide carefully and keep it for future reference.
- Follow all instructions for safe use and handling of the product.
- Use the camera within the given temperature, humidity and voltage level noted in the specifications. And only use accessories approved by the manufacturer.
- Do not disassemble the camera.
- Avoid pointing the camera directly to sunlight or any strong light source.
- Periodic cleaning may be required. Use a damp cloth only. Do not use any corrosive or chemical-based cleaners.

Disclaimer:

- This camera requires the use of a UL/CSA-approved power supply.
- The use of non-compliant or unqualified power supplies may result in product damage and void the warranty.
- The product should not be immersed in water. It is recommended to install it in a concealed location.
- Unauthorized audio recording may be illegal in certain jurisdictions. ZOSI assumes no responsibility for any use of the product that violates local laws.
- This camera features an IR CUT. A clicking sound may be heard when the camera switches between day/night modes. This sound is a normal operation indication of the camera.

What's in the Box



Camera



Power Adapter



Mounting Screw Bag



Waterproof Lid



Mounting Template



Quick Start Guide

Introduce the Camera

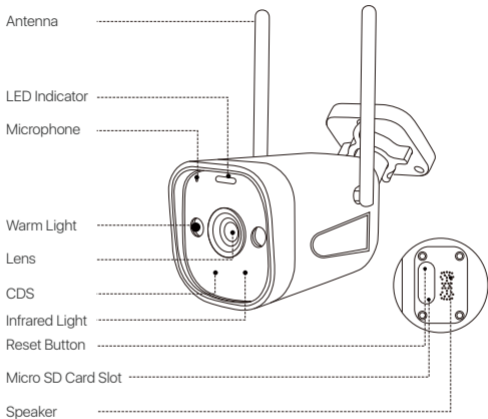

NOTE: Before installing the product, please test its functionality to ensure it is working properly. For battery-powered products, make sure they are fully charged before installation and use.

Access the System via Smartphone/PC

- **Smartphone**

Search "Zosi Smart" in App Store or scan the QR code to download and launch the App, follow the prompts to register and log in.



Zosi Smart



Android/iOS

Add Device

3 Ways to Add Device to Zosi Smart App.

- Via QR Code
- Via AP
- Via Wired Connection

For detailed instructions, please scan the QR code below to watch the Zosi Smart setup tutorial video.



- **PC**

Download: <https://www.zositech.com/pages/app>

Install the Camera

1. Installation Precautions

- Do not face the camera to any light source.
- Do not point the camera at glass windows or reflective objects. Otherwise, it may result in poor image performance due to reflections from infrared LEDs, ambient lights or status lights.
- Do not mount the camera in shaded area, and point the camera towards a well-lit area. For better image quality, make sure the camera and the captured subject are at the same lighting conditions.
- It is recommended that the camera be installed as far away as possible from electronic devices such as microwaves, televisions, radio phones and baby monitors to prevent signal interference.
- It is recommended to clean the lens with a soft cloth from time to time.
- Do not expose the power port to water or moisture, or blocked by dirt or other things.
- Do not install the camera where rain and snow may hit the lens directly.
- Camera may work in extremely cold conditions as low as -10°C as it will produce heat when powered on. You may power the camera indoors for a few minutes before installing it outdoors. (Only for outdoor cameras)

Mount the Camera to the Wall

Drill holes according to the mounting template.

NOTE: Use the anchors included in the package if needed.

Attach the camera bracket with screws included in the package.

NOTE: Run the cables through the cable notch on the mounting base. For WiFi cameras, it is recommended to mount the antenna upward or horizontally for better WiFi connection.

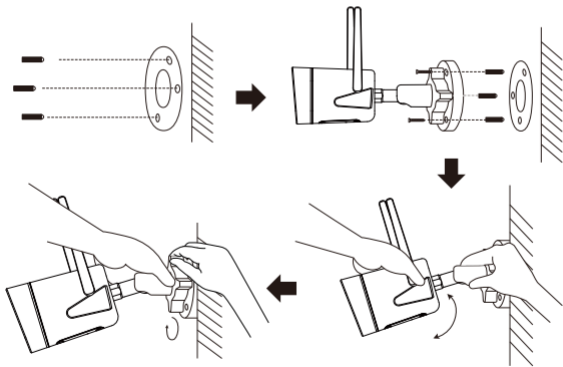

Installation Distance, Height and Angle

Distance: Best accuracy for objects within 5-50 ft (1.5-15 m).

Angle: Tilt the camera down about 30°-60° from the horizontal position.

Height: Install the camera 8-16 ft (2.5-5m) above the ground.

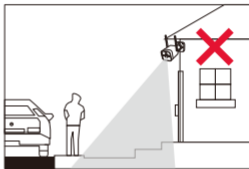
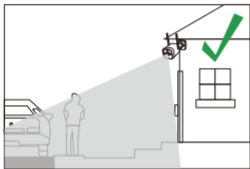

NOTE: The accuracy of human detection will be affected by various factors, such as the distance between the person and the camera, the height of the person, the height and angle of the camera, etc. The accuracy and distance of detection will also be affected in the night vision environment.

FAQ

1. Camera cannot Turn On?

If your camera is not powering on, please try the following solutions:

- Try plugging the camera into a different power outlet and check again.
- Power on the camera with another working 12V power adapter and see if it works.

If the problem persists, please contact Zositech Support: <https://support.zositech.com>

2. Wi-Fi Connection Failure During Initial Setup?

- Ensure that you have entered the correct Wi-Fi password.
- Position your camera closer to the router to ensure a strong Wi-Fi signal.

If the problem persists, please contact ZOSI support at <https://support.zositech.com>.

3. Frequent Disconnection of the Device?

- Check if the device is getting a stable internet connection.
- During installation, avoid placing the device too far from the router or in areas with weak Wi-Fi signals.
- Check if the device firmware is up to date. If not, update it to the latest version.

4. Does the camera support motion detection and image capture?

- The camera automatically captures images when it detects people, cars, or any changes in the detected image.
- Users can also manually capture images using the Zosi Smart App.

Notification of Compliance

1. FCC Compliance Statement

This device complies with Part 15 of FCC Rules.

Operation is subject to the following two conditions:

- (1) This device may not cause harmful interference.
- (2) This device must accept any interference received, including inference that may cause undesired operation.

Simplified EU Declaration of Conformity

ZOSI declares that the device is in compliance with the essential requirements and other relevant provisions if Directive 2014/53/EU.



Correct Disposal of this Product

This marking indicates that this product cannot be disposed with other household wastes throughout the EU. To prevent possible harm to the environment or human health from uncontrolled waste disposal and promote the sustainable reuse of material resources, please recycle it responsibly. To return your used device, please visit the Return and Collection System or contact the retailer from whom the product was purchased. They can take this product away for environmentally safe recycling.

NOTE: This equipment has been tested and found to comply with the limits for a Class B digital device, pursuant to part 15 of the FCC Rules. These limits are designed to provide reasonable protection against harmful interference in a residential installation. This equipment generates, uses and can radiate radio frequency energy and, if not installed and used in accordance with the instructions, may cause harmful interference to radio communications. However, there is no guarantee that interference will not occur in a particular installation. If this equipment does cause harmful interference to radio or television reception, which can be determined by turning the equipment off and on, the user is encouraged to try to correct the interference by one or more of the following measures:

- Reorient or relocate the receiving antenna.
 - Increase the separation between the equipment and receiver.
 - Connect the equipment into an outlet on a circuit different from that to which the receiver is connected.
 - Consult the dealer or an experienced radio/TV technician for help
- Changes or modifications not expressly approved by the party responsible for compliance could void the user's authority to operate the equipment.

This device complies with Part 15 of the FCC Rules. Operation is subject to the following two conditions:

(1) this device may not cause harmful interference, and (2) this device must accept any interference received, including interference that may cause undesired operation.

RF Exposure Warning Statements:

This equipment complies with FCC radiation exposure limits set forth for an uncontrolled environment. This equipment shall be installed and operated with minimum distance 20cm between the radiator & body.

This device contains licence-exempt transmitter(s)/receiver(s) that comply with Innovation, Science and Economic Development Canada's licence-exempt RSS(s). Operation is subject to the following two conditions:

- (1) This device may not cause interference.
- (2) This device must accept any interference, including interference that may cause undesired operation of the device.

L'émetteur/récepteur exempt de licence contenu dans le présent appareil est conforme aux CNR d'Innovation, Sciences et Développement économique Canada applicables aux appareils radio exempts de licence. L'exploitation est autorisée aux deux conditions suivantes :

- (1) L'appareil ne doit pas produire de brouillage;
- (2) L'appareil doit accepter tout brouillage radioélectrique subi, même si le brouillage est susceptible d'en compromettre le fonctionnement.

Radio Frequency Exposure Statement for IC

This equipment complies with IC exposure limits set forth for an uncontrolled environment. The device can be used in portable exposure conditions. This equipment shall be installed and operated with minimum distance 20cm between the radiator & body.

Cet équipement est conforme aux limites d'exposition IC établies pour un environnement non contrôlé. L'appareil peut être utilisé dans des conditions d'exposition portables. Cet équipement doit être installé et utilisé avec une distance minimale de 20 cm entre le radiateur et le corps.

ZOSI



www.zositech.com

Support Email: service@zositech.com

Facebook: <https://www.facebook.com/ZosiTechnology/>

Whatsapp: +1-866-841-6932

UK Whatsapp: +86 18675610962

Responsible Party: Ansjer Electronics Co., Ltd

Company name : Loocam Technology LLC

Address: 2205 Hutton Dr, Unit 100, Carrollton TX 75006

Tel: 657-223-3477

E-mail: lavenderl@loocam.com

Copyright © 2023 ZOSI Technology Co., Ltd.

No part of this publication may be reproduced in any way without the written permission of ZOSI. The information in this publication is believed to be accurate in all respects. ZOSI assumes no responsibility for any consequences resulting from their use. As our products require continuous improvement, ZOSI reserves the right to modify product designs, specifications and prices without notice and without any obligation. All rights reserved, and ZOSI reserves the final interpretation right of this manual.



RoHS

F920808Z3008180