



Test Report No.: RF170829W003-3



FCC TEST REPORT

(Part 15, Subpart E)

Product: LTE Mobile Phone

Model No.: M721L

FCC ID: 2ANQ6-M721L

Applicant: Meizu Technology Co., Ltd.

Address: Meizu Tech Bldg., Technology & Innovation Coast, Zhuhai, Guangdong Province, China

Manufacturer: Meizu Technology Co., Ltd.

Address: Meizu Tech Bldg., Technology & Innovation Coast, Zhuhai, Guangdong Province, China

Prepared by: BV 7Layers Communications Technology (Shenzhen) Co. Ltd

Lab Location: No.B102, Dazu Chuangxin Mansion, North of Beihuan Avenue, North Area, Hi-Tech Industrial Park, Nanshan District, Shenzhen, Guangdong, China

TEL: +86 755 8869 6566

FAX: +86 755 8869 6577

E-MAIL: customerservice.dg@cn.bureauveritas.com

Report No.: RF170829W003-3

Received Date: Sep. 26, 2017

Test Date: Oct. 08, 2017 ~ Oct. 31, 2017

Issued Date: Nov. 01, 2017

This report should not be used by the client to claim product certification, approval, or endorsement by A2LA or any government agencies.

Any copying or replication of this report to or for any other person or entity, or use of our name or trademark, is permitted only with our prior written permission. This report sets forth our findings solely with respect to the test samples identified herein. The results set forth in this report are not indicative or representative of the quality or characteristics of the lot from which a test sample was taken or any similar or identical product unless specifically and expressly noted. Our report includes all of the tests requested by you and the results thereof based upon the information that you provided to us. You have 60 days from date of issuance of this report to notify us of any material error or omission caused by our negligence, provided, however, that such notice shall be in writing and shall specifically address the issue you wish to raise. A failure to raise such issue within the prescribed time shall constitute your unqualified acceptance of the completeness of this report, the tests conducted and the correctness of the report contents. Unless specific mention, the uncertainty of measurement has been explicitly taken into account to declare the compliance or non-compliance to the specification.



TABLE OF CONTENTS

RELEASE CONTROL RECORD	4
1 CERTIFICATION	5
2 SUMMARY OF TEST RESULTS.....	6
2.1 MEASUREMENT UNCERTAINTY	6
3 GENERAL INFORMATION.....	7
3.1 GENERAL DESCRIPTION OF EUT	7
3.2 DESCRIPTION OF TEST MODES	9
3.2.1 TEST MODE APPLICABILITY AND TESTED CHANNEL DETAIL.....	11
3.3 DUTY CYCLE OF TEST SIGNAL	14
3.4 DESCRIPTION OF SUPPORT UNITS	15
3.4.1 CONFIGURATION OF SYSTEM UNDER TEST	16
3.5 GENERAL DESCRIPTION OF APPLIED STANDARDS	16
4 TEST TYPES AND RESULTS.....	17
4.1 RADIATED EMISSION AND BANDEDGE MEASUREMENT.....	17
4.1.1 LIMITS OF RADIATED EMISSION AND BANDEDGE MEASUREMENT.....	17
4.1.2 LIMITS OF UNWANTED EMISSION.....	17
4.1.3 TEST INSTRUMENTS.....	18
4.1.4 TEST PROCEDURES	19
4.1.5 DEVIATION FROM TEST STANDARD	19
4.1.6 TEST SETUP.....	20
4.1.7 EUT OPERATING CONDITION	21
4.1.8 TEST RESULTS	22
4.2 CONDUCTED EMISSION MEASUREMENT	65
4.2.1 LIMITS OF CONDUCTED EMISSION MEASUREMENT	65
4.2.2 TEST INSTRUMENTS.....	65
4.2.3 TEST PROCEDURES	65
4.2.4 DEVIATION FROM TEST STANDARD	66
4.2.5 TEST SETUP.....	66
4.2.6 EUT OPERATING CONDITIONS	66
4.2.7 TEST RESULTS	67
4.3 MAXIMUM CONDUCTED OUTPUT POWER MEASUREMENT	69



4.3.1	LIMITS OF MAXIMUM CONDUCTED OUTPUT POWER MEASUREMENT	69
4.3.2	TEST SETUP	69
4.3.3	TEST INSTRUMENTS.....	70
4.3.4	TEST PROCEDURE.....	70
4.3.5	DEVIATION FROM TEST STANDARD	71
4.3.6	EUT OPERATING CONDITIONS	71
4.3.7	TEST RESULTS	72
4.4	MAXIMUM POWER SPECTRAL DENSITY MEASUREMENT.....	83
4.4.1	LIMITS OF MAXIMUM POWER SPECTRAL DENSITY MEASUREMENT	83
4.4.2	TEST SETUP	83
4.4.3	TEST INSTRUMENTS.....	83
4.4.4	TEST PROCEDURES	84
4.4.5	DEVIATION FROM TEST STANDARD	84
4.4.6	EUT OPERATING CONDITIONS	84
4.4.7	TEST RESULTS	85
4.5	FREQUENCY STABILITY	91
4.5.1	LIMITS OF FREQUENCY STABILITY MEASUREMENT	91
4.5.2	TEST SETUP	91
4.5.3	TEST INSTRUMENTS.....	91
4.5.4	TEST PROCEDURE.....	92
4.5.5	DEVIATION FROM TEST STANDARD	92
4.5.6	EUT OPERATING CONDITION	92
4.5.7	TEST RESULTS	93
5	PHOTOGRAPHS OF THE TEST CONFIGURATION	95
6	APPENDIX A – MODIFICATIONS RECORDERS FOR ENGINEERING CHANGES TO THE EUT BY THE LAB	96



Test Report No.: RF170829W003-3

RELEASE CONTROL RECORD

ISSUE NO.	REASON FOR CHANGE	DATE ISSUED
RF170829W003-3	Original release	Nov. 01, 2017



1 CERTIFICATION

PRODUCT: LTE Mobile Phone
BRAND NAME: MEIZU
MODEL NO.: M721L
APPLICANT: Meizu Technology Co., Ltd.
TESTED: Oct. 08, 2017 ~ Oct. 31, 2017
TEST SAMPLE: Production Unit
STANDARDS: **FCC Part 15, Subpart E (15.407), Section 15.407**
ANSI C63.10-2013

The above equipment has been tested by **BV 7Layers Communications Technology (Shenzhen) Co. Ltd** and found compliance with the requirement of the above standards. The test record, data evaluation & Equipment Under Test (EUT) configurations represented herein are true and accurate accounts of the measurements of the sample's EMC characteristics under the conditions specified in this report.

PREPARED BY : Yuqiang Yin , **DATE:** Nov. 01, 2017
(Yuqiang Yin/ Engineer)

APPROVED BY : Bill Yao , **DATE:** Nov. 01, 2017
(Bill Yao / Manager)

2 SUMMARY OF TEST RESULTS

The EUT has been tested according to the following specifications:

APPLIED STANDARD: FCC PART 15, SUBPART E (SECTION 15.407)			
STANDARD SECTION	TEST TYPE AND LIMIT	RESULT	REMARK
15.407(b)(5)	AC Power Conducted Emission	PASS	Meet the requirement of limit. Minimum passing margin is -8.72dB at 0.584000MHz.
15.407(b) (1/2/3/4/6)	Radiated Emission & Band Edge Measurement	PASS	Meet the requirement of limit. Minimum passing margin is -2.54dB at 5470.00MHz.
15.407(a/1/2/3)	Maximum conducted output Power	PASS	Meet the requirement of limit.
15.407(a/1/2/3)	Peak Power Spectral Density	PASS	Meet the requirement of limit.
15.407(e)	6 dB Bandwidth	PASS	Meet the requirement of limit. (U-NII-3 Band only)
15.407(g)	Frequency Stability	PASS	Meet the requirement of limit.
15.203	Antenna Requirement	PASS	No antenna connector is used.

2.1 MEASUREMENT UNCERTAINTY

Where relevant, the following measurement uncertainty levels have been estimated for tests performed on the EUT as specified in CISPR 16-4-2:

MEASUREMENT	FREQUENCY	UNCERTAINTY
Conducted emissions	9kHz~30MHz	2.66dB
Radiated emissions	9KHz ~ 30MHz	2.68dB
	30MHz ~ 1GMHz	3.26dB
	1GHz ~ 18GHz	4.48dB
	18GHz ~ 40GHz	4.12dB

This uncertainty represents an expanded uncertainty expressed at approximately the 95% confidence level using a coverage factor of $k = 2$.

3 GENERAL INFORMATION

3.1 GENERAL DESCRIPTION OF EUT

EUT	LTE Mobile Phone
MODEL NO.	M721L
POWER SUPPLY	5.0Vdc (adapter or host equipment) 3.85Vdc (Li-polymer, battery)
MODULATION TYPE	64QAM, 16QAM, QPSK, BPSK
MODULATION TECHNOLOGY	OFDM
TRANSFER RATE	802.11a: 54.0/ 48.0/ 36.0/ 24.0/ 18.0/ 12.0/ 9.0/ 6.0Mbps 802.11n: up to MCS7
OPERATING FREQUENCY	5180 ~ 5240MHz, 5260 ~ 5320MHz 5500 ~ 5700MHz, 5745 ~ 5825MHz
NUMBER OF CHANNEL	5180 ~ 5240MHz: 4 for 802.11a, 802.11n (20MHz) 2 for 802.11n (40MHz) 5260 ~ 5320MHz: 4 for 802.11a, 802.11n (20MHz) 2 for 802.11n (40MHz) 5500 ~ 5700MHz: 8 for 802.11a, 802.11n (20MHz) 3 for 802.11n (40MHz) 5745 ~ 5825MHz: 5 for 802.11a, 802.11n (20MHz) 2 for 802.11n (40MHz)
AVERAGE POWER	23.335mW for 5180 ~ 5240MHz 21.677mW for 5260 ~ 5320MHz 17.701mW for 5500 ~ 5700MHz 17.660mW for 5745 ~ 5825MHz
ANTENNA TYPE	5180 ~ 5240MHz: PIFA Antenna with 0.61dBi gain 5260 ~ 5320MHz: PIFA Antenna with 0.61dBi gain 5500 ~ 5700MHz: PIFA Antenna with 0.39dBi gain 5745 ~ 5825MHz: PIFA Antenna with 1.06dBi gain
HW VERSION	V1.0
SW VERSION	Flyme 6.1.4.0G
I/O PORTS	Refer to user's manual
CABLE SUPPLIED	USB cable: non-shielded, detachable, 1.0m

NOTE:

1. For a more detailed features description, please refer to the manufacturer's specifications or the user's manual.

2. The EUT was powered by the following adapter:

ADAPTER	
BRAND:	DONGGUAN AOHAİ POWER TECHNOLOGY CO,LTD.
MODEL:	UP1220A
INPUT:	AC 100-240V, 700mA
OUTPUT:	DC 5V/9V/12V, 2000mA

3. The EUT matched the following USB cable:

USB CABLE	
BRAND:	N/A
MODEL:	K96092AA1
SIGNAL LINE:	1.0 METER

4. The EUT incorporates a SISO function. Physically, the EUT provides one completed transmitter and one receiver.

MODULATION MODE	TX FUNCTION
802.11a	1TX/1RX
802.11n (20MHz)	1TX/1RX
802.11n (40MHz)	1TX/1RX

5. For the test results, the EUT had been tested with all conditions. But only the worst case was shown in test report.

3.2 DESCRIPTION OF TEST MODES

FOR 5150 ~ 5250MHz

4 channels are provided for 802.11a, 802.11n (20MHz):

CHANNEL	FREQUENCY	CHANNEL	FREQUENCY
36	5180 MHz	44	5220 MHz
40	5200 MHz	48	5240 MHz

2 channels are provided for 802.11n (40MHz):

CHANNEL	FREQUENCY	CHANNEL	FREQUENCY
38	5190 MHz	46	5230 MHz

FOR 5250 ~ 5350MHz

4 channels are provided for 802.11a, 802.11n (20MHz):

CHANNEL	FREQUENCY	CHANNEL	FREQUENCY
52	5260 MHz	60	5300 MHz
56	5280 MHz	64	5320 MHz

2 channels are provided for 802.11n (40MHz):

CHANNEL	FREQUENCY	CHANNEL	FREQUENCY
54	5270 MHz	62	5310 MHz
58	5290 MHz		

FOR 5000 ~ 5700MHz

8 channels are provided for 802.11a, 802.11n (20MHz):

CHANNEL	FREQUENCY	CHANNEL	FREQUENCY
100	5500 MHz	116	5580 MHz
104	5520 MHz	132	5660 MHz
108	5540 MHz	136	5680 MHz
112	5560 MHz	140	5700 MHz

3 channels are provided for 802.11n (40MHz):

CHANNEL	FREQUENCY	CHANNEL	FREQUENCY
102	5510 MHz	134	5670 MHz
110	5550 MHz		

FOR 5725 ~ 5825MHz

5 channels are provided for 802.11a, 802.11n (20MHz):

CHANNEL	FREQUENCY	CHANNEL	FREQUENCY
149	5745 MHz	161	5805 MHz
153	5765 MHz	165	5825 MHz
157	5785 MHz		

2 channels are provided for 802.11n (40MHz):

CHANNEL	FREQUENCY	CHANNEL	FREQUENCY
151	5755 MHz	159	5795 MHz

3.2.1 TEST MODE APPLICABILITY AND TESTED CHANNEL DETAIL

EUT CONFIGURE MODE	APPLICABLE TO				DESCRIPTION
	RE≥1G	RE<1G	PLC	APCM	
A	√	√	√	-	Powered by Adapter with wifi(5G) link
B	-	-	-	√	Powered by Battery with wifi(5G) link
C	-	-	-	-	Powered by USB with wifi(5G) link

Where **RE≥1G**: Radiated Emission above 1GHz **RE<1G**: Radiated Emission below 1GHz
PLC: Power Line Conducted Emission **APCM**: Antenna Port Conducted Measurement

NOTE:

The EUT had been pre-tested on the positioned of each 3 axis. The worst case was found when positioned on **X-plane**.

NOTE: "-" means no effect.

RADIATED EMISSION TEST (ABOVE 1GHz):

- Pre-Scan has been conducted to determine the worst-case mode from all possible combinations between available modulations, data rates and antenna ports (if EUT with antenna diversity architecture).
- Following channel(s) was (were) selected for the final test as listed below.

EUT CONFIGURE MODE	MODE	FREQ. BAND (MHz)	AVAILABLE CHANNEL	TESTED CHANNEL	MODULATION TECHNOLOGY	MODULATION TYPE	DATA RATE (Mbps)
A	802.11a	5180-5240	36 to 48	36, 40, 48	OFDM	BPSK	6.0
A	802.11n (20MHz)		36 to 48	36, 40, 48	OFDM	BPSK	MCS0
A	802.11n (40MHz)		38 to 46	38, 46	OFDM	BPSK	MCS0
A	802.11a	5260-5320	52 to 64	52, 60, 64	OFDM	BPSK	6.0
A	802.11n (20MHz)		52 to 64	52, 60, 64	OFDM	BPSK	MCS0
A	802.11n (40MHz)		54 to 62	54, 62	OFDM	BPSK	MCS0
A	802.11a	5500-5700	100 to 140	100, 116, 140	OFDM	BPSK	6.0
A	802.11n (20MHz)		100 to 140	100, 116, 140	OFDM	BPSK	MCS0
A	802.11n (40MHz)		102 to 134	102, 110, 134	OFDM	BPSK	MCS0
A	802.11a	5725-5825	149 to 165	149, 157, 165	OFDM	BPSK	6.0
A	802.11n (20MHz)		149 to 165	149, 157, 165	OFDM	BPSK	MCS0
A	802.11n (40MHz)		151 to 159	151, 159	OFDM	BPSK	MCS0

RADIATED EMISSION TEST (BELOW 1GHz):

- Pre-Scan has been conducted to determine the worst-case mode from all possible combinations between available modulations, data rates and antenna ports (if EUT with antenna diversity architecture).
- Following channel(s) was (were) selected for the final test as listed below.

EUT CONFIGURE MODE	MODE	FREQ. BAND (MHz)	AVAILABLE CHANNEL	TESTED CHANNEL	MODULATION TECHNOLOGY	MODULATION TYPE	DATA RATE (Mbps)
A	802.11n (40MHz)	5500-5700	102 to 134	102	OFDM	BPSK	MCS0



POWER LINE CONDUCTED EMISSION TEST:

- Pre-Scan has been conducted to determine the worst-case mode from all possible combinations between available modulations, data rates and antenna ports (if EUT with antenna diversity architecture).
- Following channel(s) was (were) selected for the final test as listed below.

EUT CONFIGURE MODE	MODE	FREQ. BAND (MHz)	AVAILABLE CHANNEL	TESTED CHANNEL	MODULATION TECHNOLOGY	MODULATION TYPE	DATA RATE (Mbps)
A	802.11n (40MHz)	5500-5700	102 to 134	102	OFDM	BPSK	MCS0

BANDEDGE MEASUREMENT:

- Pre-Scan has been conducted to determine the worst-case mode from all possible combinations between available modulations, data rates and antenna ports (if EUT with antenna diversity architecture).
- Following channel(s) was (were) selected for the final test as listed below.

EUT CONFIGURE MODE	MODE	FREQ. BAND (MHz)	AVAILABLE CHANNEL	TESTED CHANNEL	MODULATION TECHNOLOGY	MODULATION TYPE	DATA RATE (Mbps)
A	802.11a	5180-5240	36 to 48	36, 48	OFDM	BPSK	6.0
A	802.11n (20MHz)		36 to 48	36, 48	OFDM	BPSK	MCS0
A	802.11n (40MHz)		38 to 46	38, 46	OFDM	BPSK	MCS0
A	802.11a	5260-5320	52 to 64	52, 64	OFDM	BPSK	6.0
A	802.11n (20MHz)		52 to 64	52, 64	OFDM	BPSK	MCS0
A	802.11n (40MHz)		54 to 62	54, 62	OFDM	BPSK	MCS0
A	802.11a	5500-5700	100 to 140	100, 140	OFDM	BPSK	6.0
A	802.11n (20MHz)		100 to 140	100, 140	OFDM	BPSK	MCS0
A	802.11n (40MHz)		102 to 134	102, 134	OFDM	BPSK	MCS0
A	802.11a	5725-5825	149 to 165	149, 165	OFDM	BPSK	6.0
A	802.11n (20MHz)		149 to 165	149, 165	OFDM	BPSK	MCS0
A	802.11n (40MHz)		151 to 159	151, 159	OFDM	BPSK	MCS0

ANTENNA PORT CONDUCTED MEASUREMENT:

- This item includes all test value of each mode, but only includes spectrum plot of worst value of each mode.
- Pre-Scan has been conducted to determine the worst-case mode from all possible combinations between available modulations, data rates and antenna ports (if EUT with antenna diversity architecture).
- Following channel(s) was (were) selected for the final test as listed below.

EUT CONFIGURE MODE	MODE	FREQ. BAND (MHz)	AVAILABLE CHANNEL	TESTED CHANNEL	MODULATION TECHNOLOGY	MODULATION TYPE	DATA RATE (Mbps)
B	802.11a	5180-5240	36 to 48	36, 40, 48	OFDM	BPSK	6.0
B	802.11n (20MHz)		36 to 48	36, 40, 48	OFDM	BPSK	MCS0
B	802.11n (40MHz)		38 to 46	38, 46	OFDM	BPSK	MCS0
B	802.11a	5260-5320	52 to 64	52, 60, 64	OFDM	BPSK	6.0
B	802.11n (20MHz)		52 to 64	52, 60, 64	OFDM	BPSK	MCS0
B	802.11n (40MHz)		54 to 62	54, 62	OFDM	BPSK	MCS0
B	802.11a	5500-5700	100 to 140	100, 140	OFDM	BPSK	6.0
B	802.11n (20MHz)		100 to 140	100, 140	OFDM	BPSK	MCS0
B	802.11n (40MHz)		102 to 134	102, 134	OFDM	BPSK	MCS0
B	802.11a	5725-5825	149 to 165	149, 165	OFDM	BPSK	6.0
B	802.11n (20MHz)		149 to 165	149, 165	OFDM	BPSK	MCS0
B	802.11n (40MHz)		151 to 159	151, 159	OFDM	BPSK	MCS0

TEST CONDITION:

APPLICABLE TO	ENVIRONMENTAL CONDITIONS	INPUT POWER	TESTED BY
RE<1G	23deg. C, 62%RH	DC 5V By Adapter	Simon Yang
RE≥1G	23deg. C, 62%RH	DC 5V By Adapter	Simon Yang
PLC	24deg. C, 61%RH	DC 5V By Adapter	Jocan Guo
APCM	23.5deg. C, 60%RH	DC 3.85V By battery	Wenliang Wu

3.3 DUTY CYCLE OF TEST SIGNAL

Duty cycle of test signal is < 98%, duty factor shall be considered.

802.11a: Duty cycle = 1.360/1.565 = 0.869, Duty factor = $10 * \log(1/0.869) = 0.610$

802.11n (20MHz): Duty cycle = 1.272/1.478 = 0.861, Duty factor = $10 * \log(1/0.861) = 0.65$

802.11n (40MHz): Duty cycle = 0.635/0.845 = 0.751, Duty factor = $10 * \log(1/0.751) = 1.24$

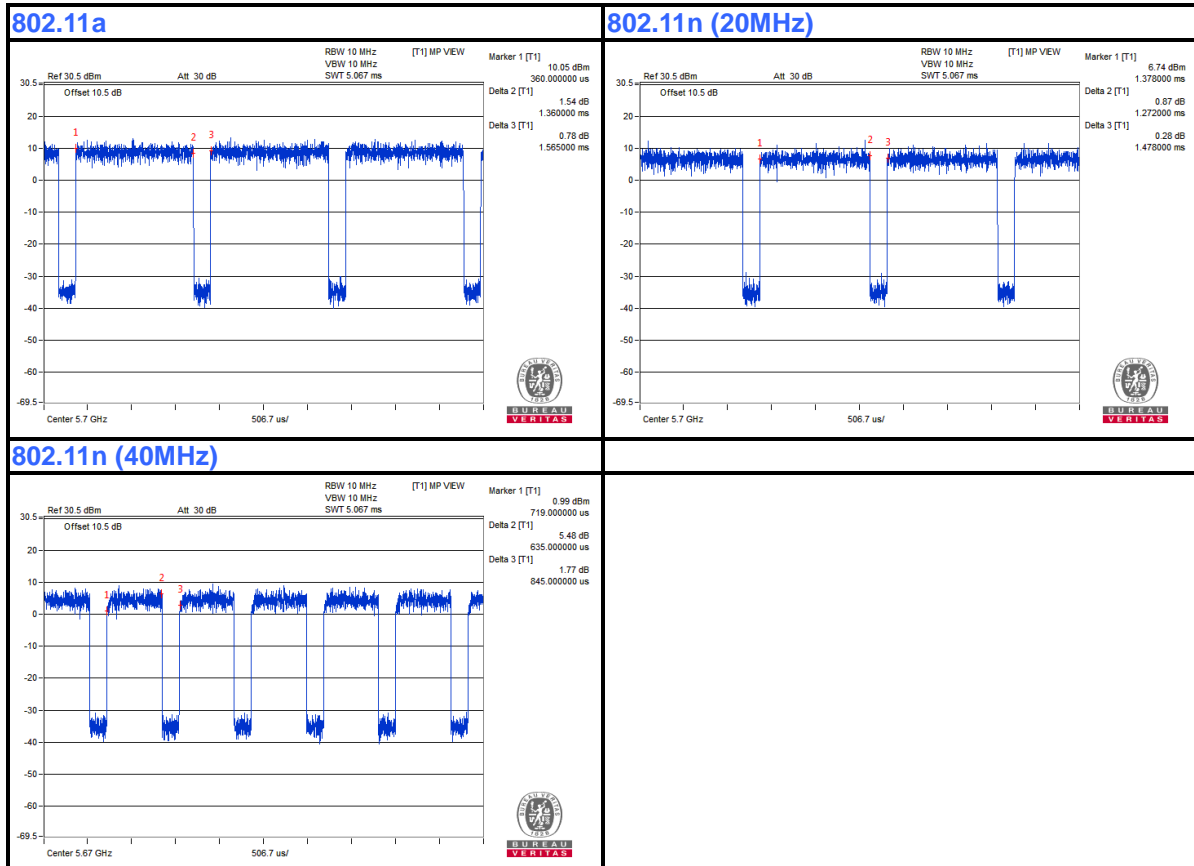



3.4 DESCRIPTION OF SUPPORT UNITS

The EUT has been tested as an independent unit together with other necessary accessories or support units. The following support units or accessories were used to form a representative test configuration during the tests.

NO.	PRODUCT	BRAND	MODEL NO.	SERIAL NO.	FCC ID
1	PC	HP	A6608CN	3CR83825X3	N/A

NO.	SIGNAL CABLE DESCRIPTION OF THE ABOVE SUPPORT UNITS
1	AC Line: Unshielded, Detachable 1.5m

NOTE:

1. All power cords of the above support units are non shielded (1.8m).

3.4.1 CONFIGURATION OF SYSTEM UNDER TEST

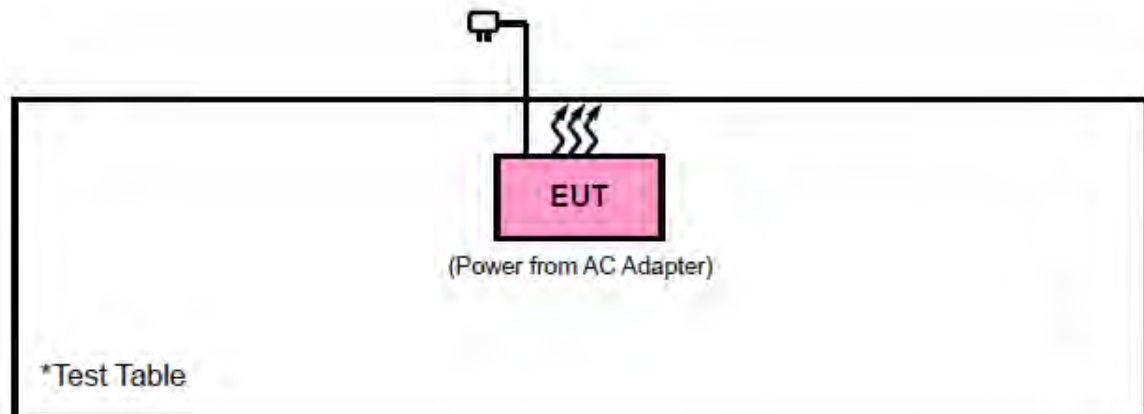

3.5 GENERAL DESCRIPTION OF APPLIED STANDARDS

The EUT is a RF Product. According to the specifications of the manufacturer, it must comply with the requirements of the following standards:

FCC Part 15, Subpart E (15.407)

KDB 789033 D02 General U-NII Test Procedures New Rules v01r02

ANSI C63.10-2013

All test items have been performed and recorded as per the above standards.

NOTE: The EUT is also considered as a kind of computer peripheral, because the connection to computer is necessary for typical use. It has been verified to comply with the requirements of FCC Part 15, Subpart B, Class B (DoC). The test report has been issued separately.

4 TEST TYPES AND RESULTS

4.1 RADIATED EMISSION AND BANDEDGE MEASUREMENT

4.1.1 LIMITS OF RADIATED EMISSION AND BANDEDGE MEASUREMENT

Radiated emissions which fall in the restricted bands must comply with the radiated emission limits specified as below table:

FREQUENCIES (MHz)	FIELD STRENGTH (microvolts/meter)	MEASUREMENT DISTANCE (meters)
0.009 ~ 0.490	2400/F(kHz)	300
0.490 ~ 1.705	24000/F(kHz)	30
1.705 ~ 30.0	30	30
30 ~ 88	100	3
88 ~ 216	150	3
216 ~ 960	200	3
Above 960	500	3

NOTE:

1. The lower limit shall apply at the transition frequencies.
2. Emission level (dBuV/m) = 20 log Emission level (uV/m).
3. For frequencies above 1000MHz, the field strength limits are based on average detector, however, the peak field strength of any emission shall not exceed the maximum permitted average limits, specified above by more than 20dB under any condition of modulation.

4.1.2 LIMITS OF UNWANTED EMISSION

RESTRICTED BANDS	APPLICABLE TO	LIMIT	
	789033 D02 General UNII Test Procedures New Rules v01r02	FIELD STRENGTH AT 3m (dBμV/m)	
		PK : 74	AV : 54
OUT OF THE RESTRICTED BANDS	APPLICABLE TO	EIRP LIMIT (dBm/MHz)	EQUIVALENT FIELD STRENGTH AT 3m (dBμV/m)
	15.407(b)(1)	PK : -27	PK : 68.3
	15.407(b)(2)		
	15.407(b)(3)		
15.407(b)(4)	See note 2 (FCC 16-24)		



NOTE: The following formula is used to convert the equipment isotropic radiated power (eirp) to field strength:

$$E = \frac{1000000\sqrt{30P}}{3} \mu\text{V/m, where P is the eirp (Watts).}$$

2. All emissions shall be limited to a level of -27 dBm/MHz at 75 MHz or more above or below the band edge increasing linearly to 10 dBm/MHz at 25 MHz above or below the band edge, and from 25 MHz above or below the band edge increasing linearly to a level of 15.6 dBm/MHz at 5 MHz above or below the band edge, and from 5 MHz above or below the band edge increasing linearly to a level of 27 dBm/MHz at the band edge.

4.1.3 TEST INSTRUMENTS

Equipment	Manufacturer	Model No.	Serial No.	Last Cal.	Next Cal.
3m Semi-anechoic Chamber	ETS-LINDGREN	9m*6m*6m	Euroshieldpn-CT0001143-1216	May 06,17	May 05,18
Bilog Antenna	ETS-LINDGREN	3143B	00161965	Nov. 26,16	Nov. 25,18
Horn Antenna	ETS-LINDGREN	3117	00168728	Nov. 26,16	Nov. 25,18
Loop antenna	Daze	ZN30900A	0708	Nov. 28,16	Nov. 27,17
Horn Antenna (18GHz-40GHz)	N/A	QWH-SL-18-40-K-SG/QMS-00361	15433	Dec. 16,16	Dec. 15,17
Test Software	E3	V 9.160323	N/A	N/A	N/A
Test Software	ADT	ADT_Radiated_V7.6.15.9.2	N/A	N/A	N/A
10dB Attenuator	JFW/USA	50HF-010-SMA	1505	Jul. 24,17	Jul. 23,18
MXE EMI Receiver	KEYSIGHT	N9038A-544	MY54450026	Mar. 10,17	Mar. 09,18
Signal Pre-Amplifier	EMSI	EMC 9135	980249	Jul. 24,17	Jul. 23,18
Signal Pre-Amplifier	EMSI	EMC 012645B	980257	Jul. 24,17	Jul. 23,18
Signal Pre-Amplifier	EMSI	EMC 184045B	980259	Jul. 24,17	Jul. 23,18

NOTE:

1. The calibration interval of the above test instruments is 12 months and the calibrations are traceable to CEPREI/CHINA, GRGT/CHINA and NIM/CHINA.
2. The test was performed in 3m Chamber.
3. The FCC Site Registration No. is 525120.

4.1.4 TEST PROCEDURES

- a. The EUT was placed on the top of a rotating table 0.8 meters (for below 1GHz) / 1.5 meters (for above 1GHz) above the ground at 3 meter chamber room for test. The table was rotated 360 degrees to determine the position of the highest radiation.
- b. The EUT was set 3 meters away from the interference-receiving antenna, which was mounted on the top of a variable-height antenna tower.
- c. The antenna is a broadband antenna, and its height is varied from one meter to four meters above the ground to determine the maximum value of the field strength. Both horizontal and vertical polarizations of the antenna are set to make the measurement.
- d. For each suspected emission, the EUT was arranged to its worst case and then the antenna was tuned to heights from 1 meter to 4 meters and the rotatable table was turned from 0 degrees to 360 degrees to find the maximum reading.
- e. The test-receiver system was set to Peak Detect Function and Specified Bandwidth with Maximum Hold Mode.
- f. If the emission level of the EUT in peak mode was 10dB lower than the limit specified, then testing could be stopped and the peak values of the EUT would be reported. Otherwise the emissions that did not have 10dB margin would be re-tested one by one using peak, quasi-peak or average method as specified and then reported in a data sheet.

NOTE:

1. The resolution bandwidth and video bandwidth of test receiver/spectrum analyzer is 120kHz for Peak detection (PK) and Quasi-peak detection (QP) at frequency below 1GHz.
2. The resolution bandwidth of test receiver/spectrum analyzer is 1MHz and video bandwidth is 3MHz for Peak detection at frequency above 1GHz.
3. The resolution bandwidth of test receiver/spectrum analyzer is 1MHz and the video bandwidth is 10Hz for Average detection (AV) at frequency above 1GHz.
4. All modes of operation were investigated and the worst-case emissions are reported.

4.1.5 DEVIATION FROM TEST STANDARD

No deviation.

4.1.6 TEST SETUP

< Frequency Range below 30MHz >

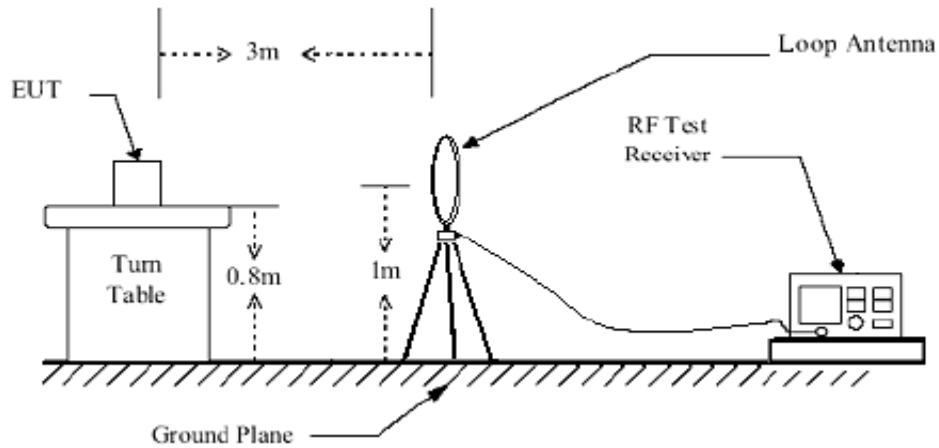

< Frequency Range 30MHz~1GHz >

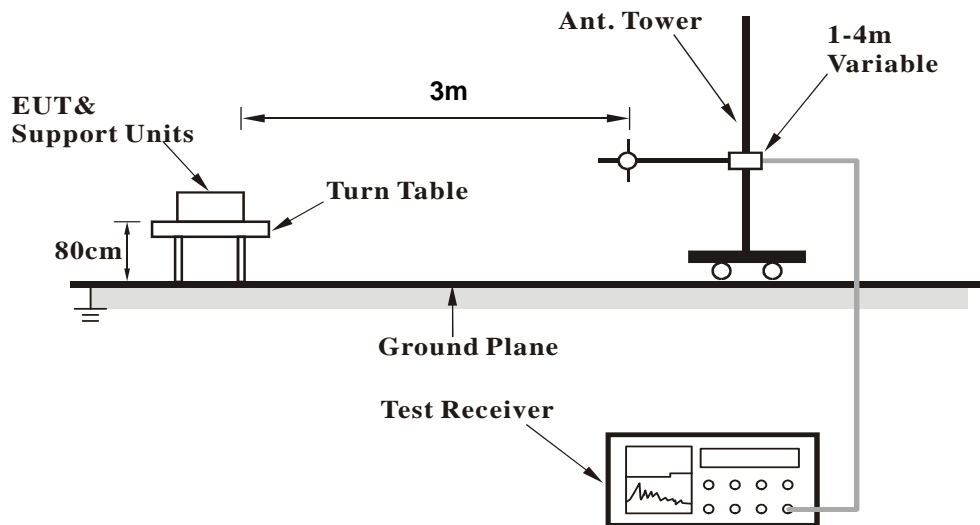

<Frequency Range above 1GHz>

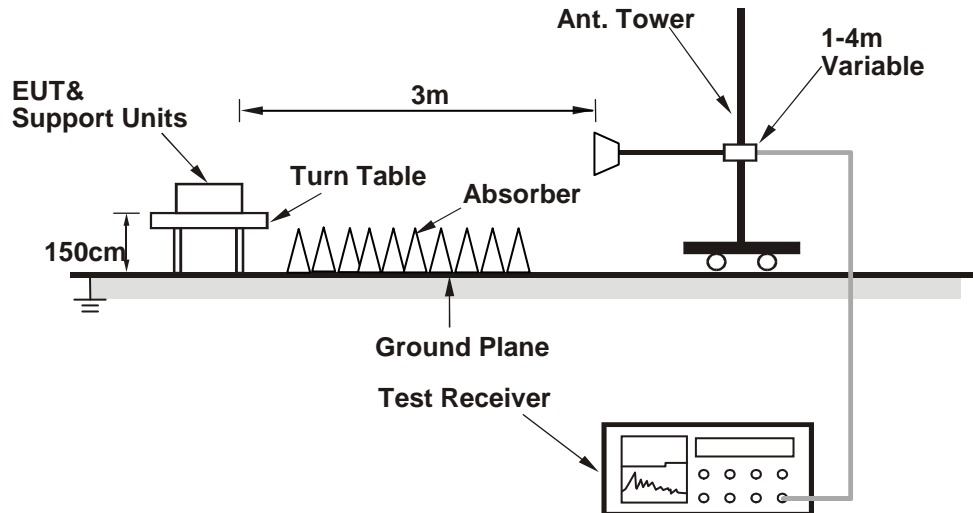

For the actual test configuration, please refer to the attached file (Test Setup Photo).

4.1.7 EUT OPERATING CONDITION

- Set the EUT under full load condition and placed them on a testing table.
- Set the transmitter part of EUT under transmission condition continuously at specific channel frequency.
- The necessary accessories enable the EUT in full functions.



4.1.8 TEST RESULTS

BELOW 1GHz WORST-CASE DATA:

9 KHz – 30 MHz data: the amplitude of spurious emissions attenuated more than 20 dB below the permissible value is not required in the report.

30 MHz – 1GHz data:

802.11n (40MHz)

CHANNEL	TX Channel 102	DETECTOR FUNCTION	Quasi-Peak (QP)
FREQUENCY RANGE	30MHz ~ 1GHz		

ANTENNA POLARITY & TEST DISTANCE: HORIZONTAL AT 3 M										
FREQ. (MHz)	EMISSION LEVEL (dBuV/m)	READ LEVEL (dBuV)	LIMIT (dBuV/m)	MARGIN (dB)	ANTENNA FACTOR (dB /m)	CABLE LOSS (dB)	PREAMP FACTOR (dB)	ANTENNA HEIGHT (cm)	TABLE ANGLE (Degree)	REMARK
53.28	35.77	65.55	40	-4.23	6.47	1.11	37.36	100	128	QP
111.48	37.84	65.58	43.5	-5.66	7.6	1.62	36.96	100	128	QP
164.83	38.6	63.24	43.5	-4.9	10.13	1.96	36.73	100	128	QP
211.39	34.78	58.47	43.5	-8.72	10.62	2.23	36.54	100	128	QP
256.01	38.78	60.35	46	-7.22	12.47	2.48	36.52	100	128	QP
351.07	34.96	53.49	46	-11.04	15.14	2.94	36.61	100	128	QP

REMARKS:

1. Emission level (dBuV/m) = Raw Value (dBuV) + Correction Factor (dB/m).
2. Correction Factor (dB/m) = Antenna Factor (dB/m) + Cable Factor (dB).
3. The other emission levels were very low against the limit.
4. Margin value = Emission level – Limit value.

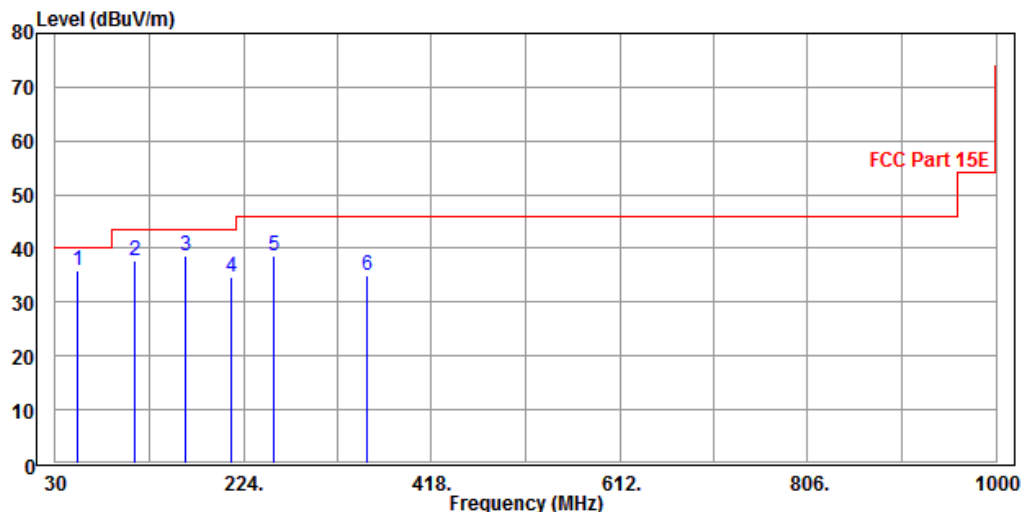



CHANNEL	Channel 102	DETECTOR FUNCTION	Quasi-Peak (QP)
FREQUENCY RANGE	30MHz ~ 1GHz		

ANTENNA POLARITY & TEST DISTANCE: VERTICAL AT 3 M										
FREQ. (MHz)	EMISSION LEVEL (dBuV/m)	READ LEVEL (dBuV)	LIMIT (dBuV/m)	MARGIN (dB)	ANTENNA FACTOR (dB /m)	CABLE LOSS (dB)	PREAMP FACTOR (dB)	ANTENNA HEIGHT (cm)	TABLE ANGLE (Degree)	REMARK
62.01	35.49	65.1	40	-4.51	6.5	1.2	37.31	100		QP
109.54	38.83	66.52	43.5	-4.67	7.67	1.61	36.97	100		QP
146.4	36.16	62.34	43.5	-7.34	8.77	1.86	36.81	100		QP
196.84	38.41	62.75	43.5	-5.09	10.07	2.15	36.56	100		QP
247.28	41.74	63.56	46	-4.26	12.27	2.43	36.52	100		QP
353.01	37.42	55.86	46	-8.58	15.23	2.95	36.62	100		QP

REMARKS:

1. Emission level (dBuV/m) = Raw Value (dBuV) + Correction Factor (dB/m).
2. Correction Factor (dB/m) = Antenna Factor (dB/m) + Cable Factor (dB).
3. The other emission levels were very low against the limit.
4. Margin value = Emission level – Limit value.

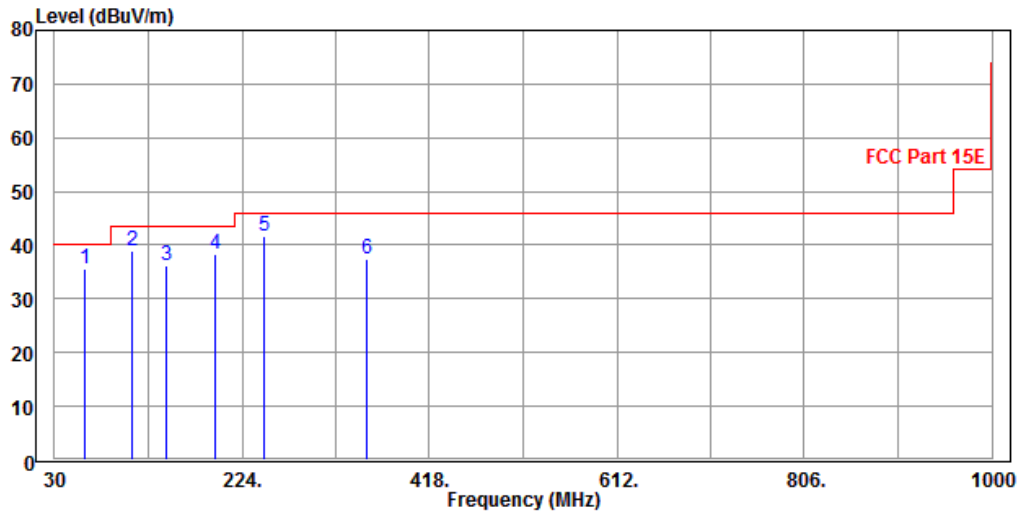



ABOVE 1GHz WORST-CASE DATA:

Note: For higher frequency, the emission is too low to be detected.

Band 1
802.11a

CHANNEL	TX Channel 36	DETECTOR FUNCTION	Peak (PK)
FREQUENCY RANGE	1GHz ~ 40GHz		Average (AV)

ANTENNA POLARITY & TEST DISTANCE: HORIZONTAL AT 3 M										
FREQ. (MHz)	EMISSION LEVEL (dBuV/m)	READ LEVEL (dBuV)	LIMIT (dBuV/m)	MARGIN (dB)	ANTENNA FACTOR (dB /m)	CABLE LOSS (dB)	PREAMP FACTOR (dB)	ANTENNA HEIGHT (cm)	TABLE ANGLE (Degree)	REMARK
5150	46.32	44.34	54	-7.68	34.48	13.71	46.21	102	172	Average
5150	62.04	60.06	74	-11.96	34.48	13.71	46.21	102	172	Peak
5180	87.4	85.31			34.52	13.79	46.22	102	172	Average
5180	97.11	95.02			34.52	13.79	46.22	102	172	Peak
5350	41.97	39.22	54	-12.03	34.72	14.28	46.25	102	172	Average
5350	54.43	51.68	74	-19.57	34.72	14.28	46.25	102	172	Peak

ANTENNA POLARITY & TEST DISTANCE: VERTICAL AT 3 M										
FREQ. (MHz)	EMISSION LEVEL (dBuV/m)	READ LEVEL (dBuV)	LIMIT (dBuV/m)	MARGIN (dB)	ANTENNA FACTOR (dB /m)	CABLE LOSS (dB)	PREAMP FACTOR (dB)	ANTENNA HEIGHT (cm)	TABLE ANGLE (Degree)	REMARK
5150	49.63	47.65	54	-4.37	34.48	13.71	46.21	100	127	Average
5150	66.43	64.45	74	-7.57	34.48	13.71	46.21	100	127	Peak
5180	90.66	88.57			34.52	13.79	46.22	100	127	Average
5180	100.39	98.3			34.52	13.79	46.22	100	127	Peak
5350	41.86	39.11	54	-12.14	34.72	14.28	46.25	100	127	Average
5350	54.86	52.11	74	-19.14	34.72	14.28	46.25	100	127	Peak

REMARKS:

- Emission Level = Read Level+ Antenna Factor + Cable Loss- Preamp Factor
Margin value = Emission level – Limit value.
- 5180MHz: Fundamental frequency.



CHANNEL	TX Channel 40	DETECTOR FUNCTION	Peak (PK)
FREQUENCY RANGE	1GHz ~ 40GHz		Average (AV)

ANTENNA POLARITY & TEST DISTANCE: HORIZONTAL AT 3 M

FREQ. (MHz)	EMISSION LEVEL (dBuV/m)	READ LEVEL (dBuV)	LIMIT (dBuV/m)	MARGIN (dB)	ANTENNA FACTOR (dB /m)	CABLE LOSS (dB)	PREAMP FACTOR (dB)	ANTENNA HEIGHT (cm)	TABLE ANGLE (Degree)	REMARK
5150	42.1	40.12	54	-11.9	34.48	13.71	46.21	120	52	Average
5150	54.63	52.65	74	-19.37	34.48	13.71	46.21	120	52	Peak
5200	87.21	85.04			34.54	13.85	46.22	120	52	Average
5200	96.69	94.52			34.54	13.85	46.22	120	52	Peak
5350	42.86	40.11	54	-11.14	34.72	14.28	46.25	120	52	Average
5350	54	51.25	74	-20	34.72	14.28	46.25	120	52	Peak

ANTENNA POLARITY & TEST DISTANCE: VERTICAL AT 3 M

FREQ. (MHz)	EMISSION LEVEL (dBuV/m)	READ LEVEL (dBuV)	LIMIT (dBuV/m)	MARGIN (dB)	ANTENNA FACTOR (dB /m)	CABLE LOSS (dB)	PREAMP FACTOR (dB)	ANTENNA HEIGHT (cm)	TABLE ANGLE (Degree)	REMARK
5150	41.57	39.59	54	-12.43	34.48	13.71	46.21	100	244	Average
5150	53.82	51.84	74	-20.18	34.48	13.71	46.21	100	244	Peak
5200	90.05	87.88			34.54	13.85	46.22	100	244	Average
5200	99.69	97.52			34.54	13.85	46.22	100	244	Peak
5350	43.61	40.86	54	-10.39	34.72	14.28	46.25	100	244	Average
5350	55.08	52.33	74	-18.92	34.72	14.28	46.25	100	244	Peak

REMARKS:

- Emission Level = Read Level+ Antenna Factor + Cable Loss- Preamp Factor
Margin value = Emission level – Limit value.
- 5200MHz: Fundamental frequency.



CHANNEL	TX Channel 48	DETECTOR FUNCTION	Peak (PK)
FREQUENCY RANGE	1GHz ~ 40GHz		Average (AV)

ANTENNA POLARITY & TEST DISTANCE: HORIZONTAL AT 3 M

FREQ. (MHz)	EMISSION LEVEL (dBuV/m)	READ LEVEL (dBuV)	LIMIT (dBuV/m)	MARGIN (dB)	ANTENNA FACTOR (dB /m)	CABLE LOSS (dB)	PREAMP FACTOR (dB)	ANTENNA HEIGHT (cm)	TABLE ANGLE (Degree)	REMARK
5150	42.08	40.1	54	-11.92	34.48	13.71	46.21	100	172	Average
5150	55.19	53.21	74	-18.81	34.48	13.71	46.21	100	172	Peak
5240	87.28	84.95			34.59	13.97	46.23	100	172	Average
5240	96.81	94.48			34.59	13.97	46.23	100	172	Peak
5350	41.74	38.99	54	-12.26	34.72	14.28	46.25	100	172	Average
5350	55.17	52.42	74	-18.83	34.72	14.28	46.25	100	172	Peak

ANTENNA POLARITY & TEST DISTANCE: VERTICAL AT 3 M

FREQ. (MHz)	EMISSION LEVEL (dBuV/m)	READ LEVEL (dBuV)	LIMIT (dBuV/m)	MARGIN (dB)	ANTENNA FACTOR (dB /m)	CABLE LOSS (dB)	PREAMP FACTOR (dB)	ANTENNA HEIGHT (cm)	TABLE ANGLE (Degree)	REMARK
5150	42.55	40.57	54	-11.45	34.48	13.71	46.21	100	127	Average
5150	54.55	52.57	74	-19.45	34.48	13.71	46.21	100	127	Peak
5240	88.1	85.77			34.59	13.97	46.23	100	127	Average
5240	98.46	96.13			34.59	13.97	46.23	100	127	Peak
5350	41.87	39.12	54	-12.13	34.72	14.28	46.25	100	127	Average
5350	54.8	52.05	74	-19.2	34.72	14.28	46.25	100	127	Peak

REMARKS:

- Emission Level = Read Level+ Antenna Factor + Cable Loss- Preamp Factor
Margin value = Emission level – Limit value.
- 5240MHz: Fundamental frequency.



802.11n (20MHz)

CHANNEL	TX Channel 36	DETECTOR FUNCTION	Peak (PK)
FREQUENCY RANGE	1GHz ~ 40GHz		Average (AV)

ANTENNA POLARITY & TEST DISTANCE: HORIZONTAL AT 3 M										
FREQ. (MHz)	EMISSION LEVEL (dBuV/m)	READ LEVEL (dBuV)	LIMIT (dBuV/m)	MARGIN (dB)	ANTENNA FACTOR (dB /m)	CABLE LOSS (dB)	PREAMP FACTOR (dB)	ANTENNA HEIGHT (cm)	TABLE ANGLE (Degree)	REMARK
5150	43.44	41.46	54	-10.56	34.48	13.71	46.21	100	173	Average
5150	54.33	52.35	74	-19.67	34.48	13.71	46.21	100	173	Peak
5180	85.54	83.45			34.52	13.79	46.22	100	173	Average
5180	96.1	94.01			34.52	13.79	46.22	100	173	Peak
5350	41.92	39.17	54	-12.08	34.72	14.28	46.25	100	173	Average
5350	55.22	52.47	74	-18.78	34.72	14.28	46.25	100	173	Peak

ANTENNA POLARITY & TEST DISTANCE: VERTICAL AT 3 M										
FREQ. (MHz)	EMISSION LEVEL (dBuV/m)	READ LEVEL (dBuV)	LIMIT (dBuV/m)	MARGIN (dB)	ANTENNA FACTOR (dB /m)	CABLE LOSS (dB)	PREAMP FACTOR (dB)	ANTENNA HEIGHT (cm)	TABLE ANGLE (Degree)	REMARK
5150	44.95	42.97	54	-9.05	34.48	13.71	46.21	100	77	Average
5150	58.05	56.07	74	-15.95	34.48	13.71	46.21	100	77	Peak
5180	87.86	85.77			34.52	13.79	46.22	100	77	Average
5180	98.86	96.77			34.52	13.79	46.22	100	77	Peak
5350	42.37	39.62	54	-11.63	34.72	14.28	46.25	100	77	Average
5350	54.5	51.75	74	-19.5	34.72	14.28	46.25	100	77	Peak

REMARKS:

- Emission Level = Read Level+ Antenna Factor + Cable Loss- Preamp Factor
Margin value = Emission level – Limit value.
- 5180MHz: Fundamental frequency.



CHANNEL	TX Channel 40	DETECTOR FUNCTION	Peak (PK)
FREQUENCY RANGE	1GHz ~ 40GHz		Average (AV)

ANTENNA POLARITY & TEST DISTANCE: HORIZONTAL AT 3 M

FREQ. (MHz)	EMISSION LEVEL (dBuV/m)	READ LEVEL (dBuV)	LIMIT (dBuV/m)	MARGIN (dB)	ANTENNA FACTOR (dB /m)	CABLE LOSS (dB)	PREAMP FACTOR (dB)	ANTENNA HEIGHT (cm)	TABLE ANGLE (Degree)	REMARK
5150	44.55	42.57	54	-9.45	34.48	13.71	46.21	144	109	Average
5150	55.42	53.44	74	-18.58	34.48	13.71	46.21	144	109	Peak
5200	80.72	78.55			34.54	13.85	46.22	144	109	Average
5200	90.69	88.52			34.54	13.85	46.22	144	109	Peak
5350	43.5	40.75	54	-10.5	34.72	14.28	46.25	144	109	Average
5350	54.39	51.64	74	-19.61	34.72	14.28	46.25	144	109	Peak

ANTENNA POLARITY & TEST DISTANCE: VERTICAL AT 3 M

FREQ. (MHz)	EMISSION LEVEL (dBuV/m)	READ LEVEL (dBuV)	LIMIT (dBuV/m)	MARGIN (dB)	ANTENNA FACTOR (dB /m)	CABLE LOSS (dB)	PREAMP FACTOR (dB)	ANTENNA HEIGHT (cm)	TABLE ANGLE (Degree)	REMARK
5150	45.55	43.57	54	-8.45	34.48	13.71	46.21	100	56	Average
5150	56.23	54.25	74	-17.77	34.48	13.71	46.21	100	56	Peak
5200	79.75	77.58			34.54	13.85	46.22	100	56	Average
5200	89.33	87.16			34.54	13.85	46.22	100	56	Peak
5350	43.52	40.77	54	-10.48	34.72	14.28	46.25	100	56	Average
5350	54.93	52.18	74	-19.07	34.72	14.28	46.25	100	56	Peak

REMARKS:

- Emission Level = Read Level+ Antenna Factor + Cable Loss- Preamp Factor
Margin value = Emission level – Limit value.
- 5200MHz: Fundamental frequency.



Test Report No.: RF170829W003-3

CHANNEL	TX Channel 48	DETECTOR FUNCTION	Peak (PK)
FREQUENCY RANGE	1GHz ~ 40GHz		Average (AV)

ANTENNA POLARITY & TEST DISTANCE: HORIZONTAL AT 3 M

FREQ. (MHz)	EMISSION LEVEL (dBuV/m)	READ LEVEL (dBuV)	LIMIT (dBuV/m)	MARGIN (dB)	ANTENNA FACTOR (dB /m)	CABLE LOSS (dB)	PREAMP FACTOR (dB)	ANTENNA HEIGHT (cm)	TABLE ANGLE (Degree)	REMARK
5150	42.09	40.11	54	-11.91	34.48	13.71	46.21	100	173	Average
5150	54.75	52.77	74	-19.25	34.48	13.71	46.21	100	173	Peak
5240	86.57	84.24			34.59	13.97	46.23	100	173	Average
5240	96.76	94.43			34.59	13.97	46.23	100	173	Peak
5350	42.79	40.04	54	-11.21	34.72	14.28	46.25	100	173	Average
5350	55.35	52.6	74	-18.65	34.72	14.28	46.25	100	173	Peak

ANTENNA POLARITY & TEST DISTANCE: VERTICAL AT 3 M

FREQ. (MHz)	EMISSION LEVEL (dBuV/m)	READ LEVEL (dBuV)	LIMIT (dBuV/m)	MARGIN (dB)	ANTENNA FACTOR (dB /m)	CABLE LOSS (dB)	PREAMP FACTOR (dB)	ANTENNA HEIGHT (cm)	TABLE ANGLE (Degree)	REMARK
5150	43.03	41.05	54	-10.97	34.48	13.71	46.21	100	80	Average
5150	56.44	54.46	74	-17.56	34.48	13.71	46.21	100	80	Peak
5240	87.02	84.69			34.59	13.97	46.23	100	80	Average
5240	96.54	94.21			34.59	13.97	46.23	100	80	Peak
5350	42.8	40.05	54	-11.2	34.72	14.28	46.25	100	80	Average
5350	55.84	53.09	74	-18.16	34.72	14.28	46.25	100	80	Peak

REMARKS:

- Emission Level = Read Level+ Antenna Factor + Cable Loss- Preamp Factor
Margin value = Emission level – Limit value.
- 5240MHz: Fundamental frequency.



802.11n (40MHz)

CHANNEL	TX Channel 38	DETECTOR FUNCTION	Peak (PK)
FREQUENCY RANGE	1GHz ~ 40GHz		Average (AV)

ANTENNA POLARITY & TEST DISTANCE: HORIZONTAL AT 3 M										
FREQ. (MHz)	EMISSION LEVEL (dBuV/m)	READ LEVEL (dBuV)	LIMIT (dBuV/m)	MARGIN (dB)	ANTENNA FACTOR (dB /m)	CABLE LOSS (dB)	PREAMP FACTOR (dB)	ANTENNA HEIGHT (cm)	TABLE ANGLE (Degree)	REMARK
5150	48.76	46.78	54	-5.24	34.48	13.71	46.21	200	173	Average
5150	65.29	63.31	74	-8.71	34.48	13.71	46.21	200	173	Peak
5190	82.53	80.4			34.53	13.82	46.22	200	173	Average
5190	93.46	91.33			34.53	13.82	46.22	200	173	Peak
5350	42.23	39.48	54	-11.77	34.72	14.28	46.25	200	173	Average
5350	54.08	51.33	74	-19.92	34.72	14.28	46.25	200	173	Peak

ANTENNA POLARITY & TEST DISTANCE: VERTICAL AT 3 M										
FREQ. (MHz)	EMISSION LEVEL (dBuV/m)	READ LEVEL (dBuV)	LIMIT (dBuV/m)	MARGIN (dB)	ANTENNA FACTOR (dB /m)	CABLE LOSS (dB)	PREAMP FACTOR (dB)	ANTENNA HEIGHT (cm)	TABLE ANGLE (Degree)	REMARK
5150	51.03	49.05	54	-2.97	34.48	13.71	46.21	100	127	Average
5150	70.46	68.48	74	-3.54	34.48	13.71	46.21	100	127	Peak
5190	85.19	83.06			34.53	13.82	46.22	100	127	Average
5190	96.44	94.31			34.53	13.82	46.22	100	127	Peak
5350	42.17	39.42	54	-11.83	34.72	14.28	46.25	100	127	Average
5350	53.61	50.86	74	-20.39	34.72	14.28	46.25	100	127	Peak

REMARKS:

- Emission Level = Read Level+ Antenna Factor + Cable Loss- Preamp Factor
Margin value = Emission level – Limit value.
- 5190MHz: Fundamental frequency.



CHANNEL	TX Channel 46	DETECTOR FUNCTION	Peak (PK)
FREQUENCY RANGE	1GHz ~ 40GHz		Average (AV)

ANTENNA POLARITY & TEST DISTANCE: HORIZONTAL AT 3 M

FREQ. (MHz)	EMISSION LEVEL (dBuV/m)	READ LEVEL (dBuV)	LIMIT (dBuV/m)	MARGIN (dB)	ANTENNA FACTOR (dB /m)	CABLE LOSS (dB)	PREAMP FACTOR (dB)	ANTENNA HEIGHT (cm)	TABLE ANGLE (Degree)	REMARK
5150	42.21	40.23	54	-11.79	34.48	13.71	46.21	100	173	Average
5150	54.12	52.14	74	-19.88	34.48	13.71	46.21	100	173	Peak
5230	82.69	80.4			34.58	13.94	46.23	100	173	Average
5230	94.09	91.8			34.58	13.94	46.23	100	173	Peak
5350	42.09	39.34	54	-11.91	34.72	14.28	46.25	100	173	Average
5350	53.36	50.61	74	-20.64	34.72	14.28	46.25	100	173	Peak

ANTENNA POLARITY & TEST DISTANCE: VERTICAL AT 3 M

FREQ. (MHz)	EMISSION LEVEL (dBuV/m)	READ LEVEL (dBuV)	LIMIT (dBuV/m)	MARGIN (dB)	ANTENNA FACTOR (dB /m)	CABLE LOSS (dB)	PREAMP FACTOR (dB)	ANTENNA HEIGHT (cm)	TABLE ANGLE (Degree)	REMARK
5150	42.48	40.5	54	-11.52	34.48	13.71	46.21	100	127	Average
5150	54.42	52.44	74	-19.58	34.48	13.71	46.21	100	127	Peak
5230	84.14	81.85			34.58	13.94	46.23	100	127	Average
5230	95.21	92.92			34.58	13.94	46.23	100	127	Peak
5350	42.17	39.42	54	-11.83	34.72	14.28	46.25	100	127	Average
5350	54.04	51.29	74	-19.96	34.72	14.28	46.25	100	127	Peak

REMARKS:

- Emission Level = Read Level+ Antenna Factor + Cable Loss- Preamp Factor
Margin value = Emission level – Limit value.
- 5230MHz: Fundamental frequency.



Band 2
802.11a

CHANNEL	TX Channel 52	DETECTOR FUNCTION	Peak (PK)
FREQUENCY RANGE	1GHz ~ 40GHz		Average (AV)

ANTENNA POLARITY & TEST DISTANCE: HORIZONTAL AT 3 M

FREQ. (MHz)	EMISSION LEVEL (dBuV/m)	READ LEVEL (dBuV)	LIMIT (dBuV/m)	MARGIN (dB)	ANTENNA FACTOR (dB /m)	CABLE LOSS (dB)	PREAMP FACTOR (dB)	ANTENNA HEIGHT (cm)	TABLE ANGLE (Degree)	REMARK
5150	42.5	40.52	54	-11.5	34.48	13.71	46.21	100	172	Average
5150	55.38	53.4	74	-18.62	34.48	13.71	46.21	100	172	Peak
5260	86.98	84.58			34.61	14.02	46.23	100	172	Average
5260	97.23	94.83			34.61	14.02	46.23	100	172	Peak
5350	42.48	39.73	54	-11.52	34.72	14.28	46.25	100	172	Average
5350	53.28	50.53	74	-20.72	34.72	14.28	46.25	100	172	Peak

ANTENNA POLARITY & TEST DISTANCE: VERTICAL AT 3 M

FREQ. (MHz)	EMISSION LEVEL (dBuV/m)	READ LEVEL (dBuV)	LIMIT (dBuV/m)	MARGIN (dB)	ANTENNA FACTOR (dB /m)	CABLE LOSS (dB)	PREAMP FACTOR (dB)	ANTENNA HEIGHT (cm)	TABLE ANGLE (Degree)	REMARK
5150	42.17	40.19	54	-11.83	34.48	13.71	46.21	105	132	Average
5150	55.31	53.33	74	-18.69	34.48	13.71	46.21	105	132	Peak
5260	89.92	87.52			34.61	14.02	46.23	105	132	Average
5260	99.58	97.18			34.61	14.02	46.23	105	132	Peak
5350	42.62	39.87	54	-11.38	34.72	14.28	46.25	105	132	Average
5350	54.02	51.27	74	-19.98	34.72	14.28	46.25	105	132	Peak

REMARKS:

- Emission Level = Read Level+ Antenna Factor + Cable Loss- Preamp Factor
Margin value = Emission level – Limit value.
- 5260MHz: Fundamental frequency.



CHANNEL	TX Channel 60	DETECTOR FUNCTION	Peak (PK)
FREQUENCY RANGE	1GHz ~ 40GHz		Average (AV)

ANTENNA POLARITY & TEST DISTANCE: HORIZONTAL AT 3 M

FREQ. (MHz)	EMISSION LEVEL (dBuV/m)	READ LEVEL (dBuV)	LIMIT (dBuV/m)	MARGIN (dB)	ANTENNA FACTOR (dB /m)	CABLE LOSS (dB)	PREAMP FACTOR (dB)	ANTENNA HEIGHT (cm)	TABLE ANGLE (Degree)	REMARK
5150	42.06	40.08	54	-11.94	34.48	13.71	46.21	156	67	Average
5150	54.2	52.22	74	-19.8	34.48	13.71	46.21	156	67	Peak
5300	88.33	85.77			34.66	14.14	46.24	156	67	Average
5300	98	95.44			34.66	14.14	46.24	156	67	Peak
5350	46.41	43.66	54	-7.59	34.72	14.28	46.25	156	67	Average
5350	57.99	55.24	74	-16.01	34.72	14.28	46.25	156	67	Peak

ANTENNA POLARITY & TEST DISTANCE: VERTICAL AT 3 M

FREQ. (MHz)	EMISSION LEVEL (dBuV/m)	READ LEVEL (dBuV)	LIMIT (dBuV/m)	MARGIN (dB)	ANTENNA FACTOR (dB /m)	CABLE LOSS (dB)	PREAMP FACTOR (dB)	ANTENNA HEIGHT (cm)	TABLE ANGLE (Degree)	REMARK
5150	42.33	40.35	54	-11.67	34.48	13.71	46.21	100	344	Average
5150	53.83	51.85	74	-20.17	34.48	13.71	46.21	100	344	Peak
5300	90.14	87.58			34.66	14.14	46.24	100	344	Average
5300	99.82	97.26			34.66	14.14	46.24	100	344	Peak
5350	46.49	43.74	54	-7.51	34.72	14.28	46.25	100	344	Average
5350	56.97	54.22	74	-17.03	34.72	14.28	46.25	100	344	Peak

REMARKS:

- Emission Level = Read Level+ Antenna Factor + Cable Loss- Preamp Factor
Margin value = Emission level – Limit value.
- 5300MHz: Fundamental frequency.



CHANNEL	TX Channel 64	DETECTOR FUNCTION	Peak (PK)
FREQUENCY RANGE	1GHz ~ 40GHz		Average (AV)

ANTENNA POLARITY & TEST DISTANCE: HORIZONTAL AT 3 M

FREQ. (MHz)	EMISSION LEVEL (dBuV/m)	READ LEVEL (dBuV)	LIMIT (dBuV/m)	MARGIN (dB)	ANTENNA FACTOR (dB /m)	CABLE LOSS (dB)	PREAMP FACTOR (dB)	ANTENNA HEIGHT (cm)	TABLE ANGLE (Degree)	REMARK
5150	42.23	40.25	54	-11.77	34.48	13.71	46.21	100	157	Average
5150	55.44	53.46	74	-18.56	34.48	13.71	46.21	100	157	Peak
5320	87.9	85.26			34.68	14.2	46.24	100	157	Average
5320	98.1	95.46			34.68	14.2	46.24	100	157	Peak
5350	43.5	40.75	54	-10.5	34.72	14.28	46.25	100	157	Average
5350	55.41	52.66	74	-18.59	34.72	14.28	46.25	100	157	Peak

ANTENNA POLARITY & TEST DISTANCE: VERTICAL AT 3 M

FREQ. (MHz)	EMISSION LEVEL (dBuV/m)	READ LEVEL (dBuV)	LIMIT (dBuV/m)	MARGIN (dB)	ANTENNA FACTOR (dB /m)	CABLE LOSS (dB)	PREAMP FACTOR (dB)	ANTENNA HEIGHT (cm)	TABLE ANGLE (Degree)	REMARK
5150	42.2	40.22	54	-11.8	34.48	13.71	46.21	105	132	Average
5150	55.34	53.36	74	-18.66	34.48	13.71	46.21	105	132	Peak
5320	88.52	85.88			34.68	14.2	46.24	105	132	Average
5320	99.35	96.71			34.68	14.2	46.24	105	132	Peak
5350	43.34	40.59	54	-10.66	34.72	14.28	46.25	105	132	Average
5350	55.39	52.64	74	-18.61	34.72	14.28	46.25	105	132	Peak

REMARKS:

- Emission Level = Read Level+ Antenna Factor + Cable Loss- Preamp Factor
Margin value = Emission level – Limit value.
- 5320MHz: Fundamental frequency.



802.11n (20MHz)

CHANNEL	TX Channel 52	DETECTOR FUNCTION	Peak (PK)
FREQUENCY RANGE	1GHz ~ 40GHz		Average (AV)

ANTENNA POLARITY & TEST DISTANCE: HORIZONTAL AT 3 M										
FREQ. (MHz)	EMISSION LEVEL (dBuV/m)	READ LEVEL (dBuV)	LIMIT (dBuV/m)	MARGIN (dB)	ANTENNA FACTOR (dB /m)	CABLE LOSS (dB)	PREAMP FACTOR (dB)	ANTENNA HEIGHT (cm)	TABLE ANGLE (Degree)	REMARK
5150	42.51	40.53	54	-11.49	34.48	13.71	46.21	100	173	Average
5150	54.48	52.5	74	-19.52	34.48	13.71	46.21	100	173	Peak
5260	86.91	84.51			34.61	14.02	46.23	100	173	Average
5260	97.04	94.64			34.61	14.02	46.23	100	173	Peak
5350	42.19	39.44	54	-11.81	34.72	14.28	46.25	100	173	Average
5350	53.7	50.95	74	-20.3	34.72	14.28	46.25	100	173	Peak

ANTENNA POLARITY & TEST DISTANCE: VERTICAL AT 3 M										
FREQ. (MHz)	EMISSION LEVEL (dBuV/m)	READ LEVEL (dBuV)	LIMIT (dBuV/m)	MARGIN (dB)	ANTENNA FACTOR (dB /m)	CABLE LOSS (dB)	PREAMP FACTOR (dB)	ANTENNA HEIGHT (cm)	TABLE ANGLE (Degree)	REMARK
5150	42.52	40.54	54	-11.48	34.48	13.71	46.21	100	110	Average
5150	54.76	52.78	74	-19.24	34.48	13.71	46.21	100	110	Peak
5260	88.07	85.67			34.61	14.02	46.23	100	110	Average
5260	98.08	95.68			34.61	14.02	46.23	100	110	Peak
5350	42.88	40.13	54	-11.12	34.72	14.28	46.25	100	110	Average
5350	55.05	52.3	74	-18.95	34.72	14.28	46.25	100	110	Peak

REMARKS:

- Emission Level = Read Level+ Antenna Factor + Cable Loss- Preamp Factor
Margin value = Emission level – Limit value.
- 5260MHz: Fundamental frequency.



CHANNEL	TX Channel 60	DETECTOR FUNCTION	Peak (PK)
FREQUENCY RANGE	1GHz ~ 40GHz		Average (AV)

ANTENNA POLARITY & TEST DISTANCE: HORIZONTAL AT 3 M

FREQ. (MHz)	EMISSION LEVEL (dBuV/m)	READ LEVEL (dBuV)	LIMIT (dBuV/m)	MARGIN (dB)	ANTENNA FACTOR (dB /m)	CABLE LOSS (dB)	PREAMP FACTOR (dB)	ANTENNA HEIGHT (cm)	TABLE ANGLE (Degree)	REMARK
5150	42.09	40.11	54	-11.91	34.48	13.71	46.21	133	84	Average
5150	54.19	52.21	74	-19.81	34.48	13.71	46.21	133	84	Peak
5300	90.41	87.85			34.66	14.14	46.24	133	84	Average
5300	100.63	98.07			34.66	14.14	46.24	133	84	Peak
5350	48.41	45.66	54	-5.59	34.72	14.28	46.25	133	84	Average
5350	57.04	54.29	74	-16.96	34.72	14.28	46.25	133	84	Peak

ANTENNA POLARITY & TEST DISTANCE: VERTICAL AT 3 M

FREQ. (MHz)	EMISSION LEVEL (dBuV/m)	READ LEVEL (dBuV)	LIMIT (dBuV/m)	MARGIN (dB)	ANTENNA FACTOR (dB /m)	CABLE LOSS (dB)	PREAMP FACTOR (dB)	ANTENNA HEIGHT (cm)	TABLE ANGLE (Degree)	REMARK
5150	42.54	40.56	54	-11.46	34.48	13.71	46.21	100	108	Average
5150	54.22	52.24	74	-19.78	34.48	13.71	46.21	100	108	Peak
5300	90.6	88.04			34.66	14.14	46.24	100	108	Average
5300	100.83	98.27			34.66	14.14	46.24	100	108	Peak
5350	47.52	44.77	54	-6.48	34.72	14.28	46.25	100	108	Average
5350	57.3	54.55	74	-16.7	34.72	14.28	46.25	100	108	Peak

REMARKS:

- Emission Level = Read Level+ Antenna Factor + Cable Loss- Preamp Factor
Margin value = Emission level – Limit value.
- 5300MHz: Fundamental frequency.



CHANNEL	TX Channel 64	DETECTOR FUNCTION	Peak (PK)
FREQUENCY RANGE	1GHz ~ 40GHz		Average (AV)

ANTENNA POLARITY & TEST DISTANCE: HORIZONTAL AT 3 M

FREQ. (MHz)	EMISSION LEVEL (dBuV/m)	READ LEVEL (dBuV)	LIMIT (dBuV/m)	MARGIN (dB)	ANTENNA FACTOR (dB /m)	CABLE LOSS (dB)	PREAMP FACTOR (dB)	ANTENNA HEIGHT (cm)	TABLE ANGLE (Degree)	REMARK
5150	42.4	40.42	54	-11.6	34.48	13.71	46.21	100	155	Average
5150	53.55	51.57	74	-20.45	34.48	13.71	46.21	100	155	Peak
5320	86.69	84.05			34.68	14.2	46.24	100	155	Average
5320	96.53	93.89			34.68	14.2	46.24	100	155	Peak
5350	42.54	39.79	54	-11.46	34.72	14.28	46.25	100	155	Average
5350	52.99	50.24	74	-21.01	34.72	14.28	46.25	100	155	Peak

ANTENNA POLARITY & TEST DISTANCE: VERTICAL AT 3 M

FREQ. (MHz)	EMISSION LEVEL (dBuV/m)	READ LEVEL (dBuV)	LIMIT (dBuV/m)	MARGIN (dB)	ANTENNA FACTOR (dB /m)	CABLE LOSS (dB)	PREAMP FACTOR (dB)	ANTENNA HEIGHT (cm)	TABLE ANGLE (Degree)	REMARK
5150	42.49	40.51	54	-11.51	34.48	13.71	46.21	100	140	Average
5150	53.35	51.37	74	-20.65	34.48	13.71	46.21	100	140	Peak
5320	85.05	82.41			34.68	14.2	46.24	100	140	Average
5320	96.41	93.77			34.68	14.2	46.24	100	140	Peak
5350	42.37	39.62	54	-11.63	34.72	14.28	46.25	100	140	Average
5350	53.32	50.57	74	-20.68	34.72	14.28	46.25	100	140	Peak

REMARKS:

- Emission Level = Read Level+ Antenna Factor + Cable Loss- Preamp Factor
Margin value = Emission level – Limit value.
- 5320MHz: Fundamental frequency.



802.11n (40MHz)

CHANNEL	TX Channel 54	DETECTOR FUNCTION	Peak (PK)
FREQUENCY RANGE	1GHz ~ 40GHz		Average (AV)

ANTENNA POLARITY & TEST DISTANCE: HORIZONTAL AT 3 M										
FREQ. (MHz)	EMISSION LEVEL (dBuV/m)	READ LEVEL (dBuV)	LIMIT (dBuV/m)	MARGIN (dB)	ANTENNA FACTOR (dB /m)	CABLE LOSS (dB)	PREAMP FACTOR (dB)	ANTENNA HEIGHT (cm)	TABLE ANGLE (Degree)	REMARK
5150	42.1	40.12	54	-11.9	34.48	13.71	46.21	100	173	Average
5150	54.5	52.52	74	-19.5	34.48	13.71	46.21	100	173	Peak
5270	82.34	79.9			34.62	14.05	46.23	100	173	Average
5270	93.27	90.83			34.62	14.05	46.23	100	173	Peak
5350	42.64	39.89	54	-11.36	34.72	14.28	46.25	100	173	Average
5350	54.47	51.72	74	-19.53	34.72	14.28	46.25	100	173	Peak

ANTENNA POLARITY & TEST DISTANCE: VERTICAL AT 3 M										
FREQ. (MHz)	EMISSION LEVEL (dBuV/m)	READ LEVEL (dBuV)	LIMIT (dBuV/m)	MARGIN (dB)	ANTENNA FACTOR (dB /m)	CABLE LOSS (dB)	PREAMP FACTOR (dB)	ANTENNA HEIGHT (cm)	TABLE ANGLE (Degree)	REMARK
5150	42.76	40.78	54	-11.24	34.48	13.71	46.21	100	145	Average
5150	54.87	52.89	74	-19.13	34.48	13.71	46.21	100	145	Peak
5270	81.33	78.89			34.62	14.05	46.23	100	145	Average
5270	92.27	89.83			34.62	14.05	46.23	100	145	Peak
5350	42.53	39.78	54	-11.47	34.72	14.28	46.25	100	145	Average
5350	53.97	51.22	74	-20.03	34.72	14.28	46.25	100	145	Peak

REMARKS:

- Emission Level = Read Level+ Antenna Factor + Cable Loss- Preamp Factor
Margin value = Emission level – Limit value.
- 5270MHz: Fundamental frequency.



CHANNEL	TX Channel 62	DETECTOR FUNCTION	Peak (PK)
FREQUENCY RANGE	1GHz ~ 40GHz		Average (AV)

ANTENNA POLARITY & TEST DISTANCE: HORIZONTAL AT 3 M

FREQ. (MHz)	EMISSION LEVEL (dBuV/m)	READ LEVEL (dBuV)	LIMIT (dBuV/m)	MARGIN (dB)	ANTENNA FACTOR (dB /m)	CABLE LOSS (dB)	PREAMP FACTOR (dB)	ANTENNA HEIGHT (cm)	TABLE ANGLE (Degree)	REMARK
5150	42.84	40.86	54	-11.16	34.48	13.71	46.21	100	155	Average
5150	54.68	52.7	74	-19.32	34.48	13.71	46.21	100	155	Peak
5310	82.55	79.95			34.67	14.17	46.24	100	155	Average
5310	92.46	89.86			34.67	14.17	46.24	100	155	Peak
5350	48.37	45.62	54	-5.63	34.72	14.28	46.25	100	155	Average
5350	63.51	60.76	74	-10.49	34.72	14.28	46.25	100	155	Peak

ANTENNA POLARITY & TEST DISTANCE: VERTICAL AT 3 M

FREQ. (MHz)	EMISSION LEVEL (dBuV/m)	READ LEVEL (dBuV)	LIMIT (dBuV/m)	MARGIN (dB)	ANTENNA FACTOR (dB /m)	CABLE LOSS (dB)	PREAMP FACTOR (dB)	ANTENNA HEIGHT (cm)	TABLE ANGLE (Degree)	REMARK
5150	42.71	40.73	54	-11.29	34.48	13.71	46.21	105	142	Average
5150	54.82	52.84	74	-19.18	34.48	13.71	46.21	105	142	Peak
5310	83.54	80.94			34.67	14.17	46.24	105	142	Average
5310	93.51	90.91			34.67	14.17	46.24	105	142	Peak
5350	48.32	45.57	54	-5.68	34.72	14.28	46.25	105	142	Average
5350	62.25	59.5	74	-11.75	34.72	14.28	46.25	105	142	Peak

REMARKS:

- Emission Level = Read Level+ Antenna Factor + Cable Loss- Preamp Factor
Margin value = Emission level – Limit value.
- 5310MHz: Fundamental frequency.



Band 3

802.11a

CHANNEL	TX Channel 100	DETECTOR FUNCTION	Peak (PK)
FREQUENCY RANGE	1GHz ~ 40GHz		Average (AV)

ANTENNA POLARITY & TEST DISTANCE: HORIZONTAL AT 3 M

FREQ. (MHz)	EMISSION LEVEL (dBuV/m)	READ LEVEL (dBuV)	LIMIT (dBuV/m)	MARGIN (dB)	ANTENNA FACTOR (dB /m)	CABLE LOSS (dB)	PREAMP FACTOR (dB)	ANTENNA HEIGHT (cm)	TABLE ANGLE (Degree)	REMARK
5460	42.9	39.72	54	-11.1	34.85	14.6	46.27	100	311	Average
5460	54.13	50.95	74	-19.87	34.85	14.6	46.27	100	311	Peak
#5470	55.24	52.03	68.3	-13.06	34.86	14.62	46.27	100	311	Peak
5500	87.58	84.25			34.9	14.71	46.28	100	311	Average
5500	42.9	39.72			34.9	14.71	46.28	100	311	Peak

ANTENNA POLARITY & TEST DISTANCE: VERTICAL AT 3 M

FREQ. (MHz)	EMISSION LEVEL (dBuV/m)	READ LEVEL (dBuV)	LIMIT (dBuV/m)	MARGIN (dB)	ANTENNA FACTOR (dB /m)	CABLE LOSS (dB)	PREAMP FACTOR (dB)	ANTENNA HEIGHT (cm)	TABLE ANGLE (Degree)	REMARK
5460	44.16	40.98	54	-9.84	34.85	14.6	46.27	100	165	Average
5460	54.46	51.28	74	-19.54	34.85	14.6	46.27	100	165	Peak
#5470	57.34	54.13	68.3	-10.96	34.86	14.62	46.27	100	165	Peak
5500	91.89	88.56			34.9	14.71	46.28	100	165	Average
5500	101.58	98.25			34.9	14.71	46.28	100	165	Peak

REMARKS:

- Emission Level = Read Level+ Antenna Factor + Cable Loss- Preamp Factor
Margin value = Emission level – Limit value.
- 5500MHz: Fundamental frequency.
- #: Out of restricted band.



CHANNEL	TX Channel 116	DETECTOR FUNCTION	Peak (PK)
FREQUENCY RANGE	1GHz ~ 40GHz		Average (AV)

ANTENNA POLARITY & TEST DISTANCE: HORIZONTAL AT 3 M										
FREQ. (MHz)	EMISSION LEVEL (dBuV/m)	READ LEVEL (dBuV)	LIMIT (dBuV/m)	MARGIN (dB)	ANTENNA FACTOR (dB /m)	CABLE LOSS (dB)	PREAMP FACTOR (dB)	ANTENNA HEIGHT (cm)	TABLE ANGLE (Degree)	REMARK
5580	93.29	89.19			35.02	15.36	46.28	100	311	Average
5580	102.66	98.56			35.02	15.36	46.28	100	311	Peak

ANTENNA POLARITY & TEST DISTANCE: VERTICAL AT 3 M										
FREQ. (MHz)	EMISSION LEVEL (dBuV/m)	READ LEVEL (dBuV)	LIMIT (dBuV/m)	MARGIN (dB)	ANTENNA FACTOR (dB /m)	CABLE LOSS (dB)	PREAMP FACTOR (dB)	ANTENNA HEIGHT (cm)	TABLE ANGLE (Degree)	REMARK
5580	90.33	86.23			35.02	15.36	46.28	100	165	Average
5580	100.16	96.06			35.02	15.36	46.28	100	165	Peak

REMARKS:

1. Emission Level = Read Level+ Antenna Factor + Cable Loss- Preamp Factor
Margin value = Emission level – Limit value.
2. 5580MHz: Fundamental frequency.



CHANNEL	TX Channel 140	DETECTOR FUNCTION	Peak (PK)
FREQUENCY RANGE	1GHz ~ 40GHz		Average (AV)

ANTENNA POLARITY & TEST DISTANCE: HORIZONTAL AT 3 M										
FREQ. (MHz)	EMISSION LEVEL (dBuV/m)	READ LEVEL (dBuV)	LIMIT (dBuV/m)	MARGIN (dB)	ANTENNA FACTOR (dB /m)	CABLE LOSS (dB)	PREAMP FACTOR (dB)	ANTENNA HEIGHT (cm)	TABLE ANGLE (Degree)	REMARK
5700	93.1	88.23			35.14	16.01	46.28	100	311	Average
5700	103.49	98.62			35.14	16.01	46.28	100	311	Peak
#5725	63.3	58.23	68.3	-5.00	35.17	16.18	46.28	100	311	Peak
ANTENNA POLARITY & TEST DISTANCE: VERTICAL AT 3 M										
FREQ. (MHz)	EMISSION LEVEL (dBuV/m)	READ LEVEL (dBuV)	LIMIT (dBuV/m)	MARGIN (dB)	ANTENNA FACTOR (dB /m)	CABLE LOSS (dB)	PREAMP FACTOR (dB)	ANTENNA HEIGHT (cm)	TABLE ANGLE (Degree)	REMARK
5700	92.16	87.29			35.14	16.01	46.28	102	211	Average
5700	102.05	97.18			35.14	16.01	46.28	102	211	Peak
#5725	63.51	58.44	68.3	-4.79	35.17	16.18	46.28	102	211	Peak

REMARKS:

- Emission Level = Read Level+ Antenna Factor + Cable Loss- Preamp Factor
Margin value = Emission level – Limit value.
- 5700MHz: Fundamental frequency.
- #: Out of restricted band.



802.11n (20MHz)

CHANNEL	TX Channel 100	DETECTOR FUNCTION	Peak (PK)
FREQUENCY RANGE	1GHz ~ 40GHz		Average (AV)

ANTENNA POLARITY & TEST DISTANCE: HORIZONTAL AT 3 M										
FREQ. (MHz)	EMISSION LEVEL (dBuV/m)	READ LEVEL (dBuV)	LIMIT (dBuV/m)	MARGIN (dB)	ANTENNA FACTOR (dB /m)	CABLE LOSS (dB)	PREAMP FACTOR (dB)	ANTENNA HEIGHT (cm)	TABLE ANGLE (Degree)	REMARK
5460	42.78	39.6	54	-11.22	34.85	14.6	46.27	122	170	Average
5460	54.31	51.13	74	-19.69	34.85	14.6	46.27	122	170	Peak
#5470	55.13	51.92	68.3	-13.17	34.86	14.62	46.27	122	170	Peak
5500	88.68	85.35			34.9	14.71	46.28	122	170	Average
5500	98.35	95.02			34.9	14.71	46.28	122	170	Peak

ANTENNA POLARITY & TEST DISTANCE: VERTICAL AT 3 M										
FREQ. (MHz)	EMISSION LEVEL (dBuV/m)	READ LEVEL (dBuV)	LIMIT (dBuV/m)	MARGIN (dB)	ANTENNA FACTOR (dB /m)	CABLE LOSS (dB)	PREAMP FACTOR (dB)	ANTENNA HEIGHT (cm)	TABLE ANGLE (Degree)	REMARK
5460	43.66	40.48	54	-10.34	34.85	14.6	46.27	100	162	Average
5460	53.79	50.61	74	-20.21	34.85	14.6	46.27	100	162	Peak
#5470	56.21	53	68.3	-12.09	34.86	14.62	46.27	100	162	Peak
5500	89.82	86.49			34.9	14.71	46.28	100	162	Average
5500	100.38	97.05			34.9	14.71	46.28	100	162	Peak

REMARKS:

- Emission Level = Read Level+ Antenna Factor + Cable Loss- Preamp Factor
Margin value = Emission level – Limit value.
- 5500MHz: Fundamental frequency.
- #: Out of restricted band.



CHANNEL	TX Channel 116	DETECTOR FUNCTION	Peak (PK)
FREQUENCY RANGE	1GHz ~ 40GHz		Average (AV)

ANTENNA POLARITY & TEST DISTANCE: HORIZONTAL AT 3 M										
FREQ. (MHz)	EMISSION LEVEL (dBuV/m)	READ LEVEL (dBuV)	LIMIT (dBuV/m)	MARGIN (dB)	ANTENNA FACTOR (dB /m)	CABLE LOSS (dB)	PREAMP FACTOR (dB)	ANTENNA HEIGHT (cm)	TABLE ANGLE (Degree)	REMARK
5580	89.39	85.29			35.02	15.36	46.28	122	170	Average
5580	99.47	95.37			35.02	15.36	46.28	122	170	Peak
ANTENNA POLARITY & TEST DISTANCE: VERTICAL AT 3 M										
FREQ. (MHz)	EMISSION LEVEL (dBuV/m)	READ LEVEL (dBuV)	LIMIT (dBuV/m)	MARGIN (dB)	ANTENNA FACTOR (dB /m)	CABLE LOSS (dB)	PREAMP FACTOR (dB)	ANTENNA HEIGHT (cm)	TABLE ANGLE (Degree)	REMARK
5580	90.71	86.61			35.02	15.36	46.28	125	160	Average
5580	99.23	95.13			35.02	15.36	46.28	125	160	Peak

REMARKS:

1. Emission Level = Read Level+ Antenna Factor + Cable Loss- Preamp Factor
Margin value = Emission level – Limit value.
2. 5580MHz: Fundamental frequency.



CHANNEL	TX Channel 140	DETECTOR FUNCTION	Peak (PK)
FREQUENCY RANGE	1GHz ~ 40GHz		Average (AV)

ANTENNA POLARITY & TEST DISTANCE: HORIZONTAL AT 3 M										
FREQ. (MHz)	EMISSION LEVEL (dBuV/m)	READ LEVEL (dBuV)	LIMIT (dBuV/m)	MARGIN (dB)	ANTENNA FACTOR (dB /m)	CABLE LOSS (dB)	PREAMP FACTOR (dB)	ANTENNA HEIGHT (cm)	TABLE ANGLE (Degree)	REMARK
5700	92.96	88.09			35.14	16.01	46.28	102	80	Average
5700	102.86	97.99			35.14	16.01	46.28	102	80	Peak
#5725	63.6	58.53	68.3	-4.70	35.17	16.18	46.28	102	80	Peak
ANTENNA POLARITY & TEST DISTANCE: VERTICAL AT 3 M										
FREQ. (MHz)	EMISSION LEVEL (dBuV/m)	READ LEVEL (dBuV)	LIMIT (dBuV/m)	MARGIN (dB)	ANTENNA FACTOR (dB /m)	CABLE LOSS (dB)	PREAMP FACTOR (dB)	ANTENNA HEIGHT (cm)	TABLE ANGLE (Degree)	REMARK
5700	92.6	87.73			35.14	16.01	46.28	100	164	Average
5700	102.12	97.25			35.14	16.01	46.28	100	164	Peak
#5725	63.75	58.68	68.3	-4.55	35.17	16.18	46.28	100	164	Peak

REMARKS:

- Emission Level = Read Level+ Antenna Factor + Cable Loss- Preamp Factor
Margin value = Emission level – Limit value.
- 5700MHz: Fundamental frequency.
- #: Out of restricted band.



802.11n (40MHz)

CHANNEL	TX Channel 102	DETECTOR FUNCTION	Peak (PK)
FREQUENCY RANGE	1GHz ~ 40GHz		Average (AV)

ANTENNA POLARITY & TEST DISTANCE: HORIZONTAL AT 3 M										
FREQ. (MHz)	EMISSION LEVEL (dBuV/m)	READ LEVEL (dBuV)	LIMIT (dBuV/m)	MARGIN (dB)	ANTENNA FACTOR (dB /m)	CABLE LOSS (dB)	PREAMP FACTOR (dB)	ANTENNA HEIGHT (cm)	TABLE ANGLE (Degree)	REMARK
5460	44.03	40.85	54	-9.97	34.85	14.6	46.27	102	170	Average
5460	54.34	51.16	74	-19.66	34.85	14.6	46.27	102	170	Peak
#5470	63.74	60.53	68.3	-4.56	34.86	14.62	46.27	102	170	Peak
5510	85.17	81.76			34.91	14.78	46.28	102	170	Average
5510	95.02	91.61			34.91	14.78	46.28	102	170	Peak

ANTENNA POLARITY & TEST DISTANCE: VERTICAL AT 3 M										
FREQ. (MHz)	EMISSION LEVEL (dBuV/m)	READ LEVEL (dBuV)	LIMIT (dBuV/m)	MARGIN (dB)	ANTENNA FACTOR (dB /m)	CABLE LOSS (dB)	PREAMP FACTOR (dB)	ANTENNA HEIGHT (cm)	TABLE ANGLE (Degree)	REMARK
5460	44.71	41.53	54	-9.29	34.85	14.6	46.27	100	142	Average
5460	57.41	54.23	74	-16.59	34.85	14.6	46.27	100	142	Peak
#5470	65.76	62.55	68.3	-2.54	34.86	14.62	46.27	100	142	Peak
5510	85.1	81.69			34.91	14.78	46.28	100	142	Average
5510	95.34	91.93			34.91	14.78	46.28	100	142	Peak

REMARKS:

- Emission Level = Read Level+ Antenna Factor + Cable Loss- Preamp Factor
Margin value = Emission level – Limit value.
- 5510MHz: Fundamental frequency.
- #: Out of restricted band.



Test Report No.: RF170829W003-3

CHANNEL	TX Channel 110	DETECTOR FUNCTION	Peak (PK)
FREQUENCY RANGE	1GHz ~ 40GHz		Average (AV)

ANTENNA POLARITY & TEST DISTANCE: HORIZONTAL AT 3 M

FREQ. (MHz)	EMISSION LEVEL (dBuV/m)	READ LEVEL (dBuV)	LIMIT (dBuV/m)	MARGIN (dB)	ANTENNA FACTOR (dB /m)	CABLE LOSS (dB)	PREAMP FACTOR (dB)	ANTENNA HEIGHT (cm)	TABLE ANGLE (Degree)	REMARK
5550	86.2	82.17			35.01	15.3	46.28	105	118	Average
5550	95.88	91.85			35.01	15.3	46.28	105	118	Peak

ANTENNA POLARITY & TEST DISTANCE: VERTICAL AT 3 M

FREQ. (MHz)	EMISSION LEVEL (dBuV/m)	READ LEVEL (dBuV)	LIMIT (dBuV/m)	MARGIN (dB)	ANTENNA FACTOR (dB /m)	CABLE LOSS (dB)	PREAMP FACTOR (dB)	ANTENNA HEIGHT (cm)	TABLE ANGLE (Degree)	REMARK
5550	85.99	81.96			35.01	15.3	46.28	100	142	Average
5550	95.69	91.66			35.01	15.3	46.28	100	142	Peak

REMARKS:

- Emission Level = Read Level+ Antenna Factor + Cable Loss- Preamp Factor
Margin value = Emission level – Limit value.
- 5550MHz: Fundamental frequency.



CHANNEL	TX Channel 134	DETECTOR FUNCTION	Peak (PK)
FREQUENCY RANGE	1GHz ~ 40GHz		Average (AV)

ANTENNA POLARITY & TEST DISTANCE: HORIZONTAL AT 3 M										
FREQ. (MHz)	EMISSION LEVEL (dBuV/m)	READ LEVEL (dBuV)	LIMIT (dBuV/m)	MARGIN (dB)	ANTENNA FACTOR (dB /m)	CABLE LOSS (dB)	PREAMP FACTOR (dB)	ANTENNA HEIGHT (cm)	TABLE ANGLE (Degree)	REMARK
5670	87.78	83.14			35.1	15.82	46.28	100	142	Average
5670	97.65	93.01			35.1	15.82	46.28	100	142	Peak
#5725	60.3	55.23	68.3	-8.00	35.17	16.18	46.28	100	142	Average
ANTENNA POLARITY & TEST DISTANCE: VERTICAL AT 3 M										
FREQ. (MHz)	EMISSION LEVEL (dBuV/m)	READ LEVEL (dBuV)	LIMIT (dBuV/m)	MARGIN (dB)	ANTENNA FACTOR (dB /m)	CABLE LOSS (dB)	PREAMP FACTOR (dB)	ANTENNA HEIGHT (cm)	TABLE ANGLE (Degree)	REMARK
5670	90.16	85.52			35.1	15.82	46.28	103	81	Average
5670	99.31	94.67			35.1	15.82	46.28	103	81	Peak
#5725	60.66	55.59	68.3	-7.64	35.17	16.18	46.28	103	81	Peak

REMARKS:

- Emission Level = Read Level+ Antenna Factor + Cable Loss- Preamp Factor
Margin value = Emission level – Limit value.
- 5670MHz: Fundamental frequency.
- #: Out of restricted band.



Band 4

802.11a

CHANNEL	TX Channel 149	DETECTOR FUNCTION	Peak (PK)
FREQUENCY RANGE	1GHz ~ 40GHz		Average (AV)

ANTENNA POLARITY & TEST DISTANCE: HORIZONTAL AT 3 M										
FREQ. (MHz)	EMISSION LEVEL (dBuV/m)	READ LEVEL (dBuV)	LIMIT (dBuV/m)	MARGIN (dB)	ANTENNA FACTOR (dB /m)	CABLE LOSS (dB)	PREAMP FACTOR (dB)	ANTENNA HEIGHT (cm)	TABLE ANGLE (Degree)	REMARK
5745	94.33	89.11			35.19	16.31	46.28	100	311	Average
5745	105.62	100.4			35.19	16.31	46.28	100	311	Peak
ANTENNA POLARITY & TEST DISTANCE: VERTICAL AT 3 M										
FREQ. (MHz)	EMISSION LEVEL (dBuV/m)	READ LEVEL (dBuV)	LIMIT (dBuV/m)	MARGIN (dB)	ANTENNA FACTOR (dB /m)	CABLE LOSS (dB)	PREAMP FACTOR (dB)	ANTENNA HEIGHT (cm)	TABLE ANGLE (Degree)	REMARK
5745	94	88.78			35.19	16.31	46.28	102	211	Average
5745	104.43	99.21			35.19	16.31	46.28	102	211	Peak

REMARKS:

- Emission Level = Read Level+ Antenna Factor + Cable Loss- Preamp Factor
Margin value = Emission level – Limit value.
- 5745MHz: Fundamental frequency.



OOBE DATA

802.11a

ANTENNA POLARITY & TEST DISTANCE: HORIZONTAL AT 3 M										
FREQ. (MHz)	EMISSION LEVEL (dBuV/m)	READ LEVEL (dBuV)	LIMIT (dBuV/m)	MARGIN (dB)	ANTENNA FACTOR (dB /m)	CABLE LOSS (dB)	PREAMP FACTOR (dB)	ANTENNA HEIGHT (cm)	TABLE ANGLE (Degree)	REMARK
5575.65	56.25	52.34	68.3	-12.05	34.99	15.2	46.28	100	311	Peak
6003.15	59.01	51.83	68.3	-9.29	35.5	17.96	46.28	100	311	Peak
ANTENNA POLARITY & TEST DISTANCE: VERTICAL AT 3 M										
FREQ. (MHz)	EMISSION LEVEL (dBuV/m)	READ LEVEL (dBuV)	LIMIT (dBuV/m)	MARGIN (dB)	ANTENNA FACTOR (dB /m)	CABLE LOSS (dB)	PREAMP FACTOR (dB)	ANTENNA HEIGHT (cm)	TABLE ANGLE (Degree)	REMARK
5571.85	55.97	52.08	68.3	-12.33	34.99	15.18	46.28	102	211	Peak
5974.65	59.1	52.11	68.3	-9.2	35.47	17.8	46.28	102	211	Peak

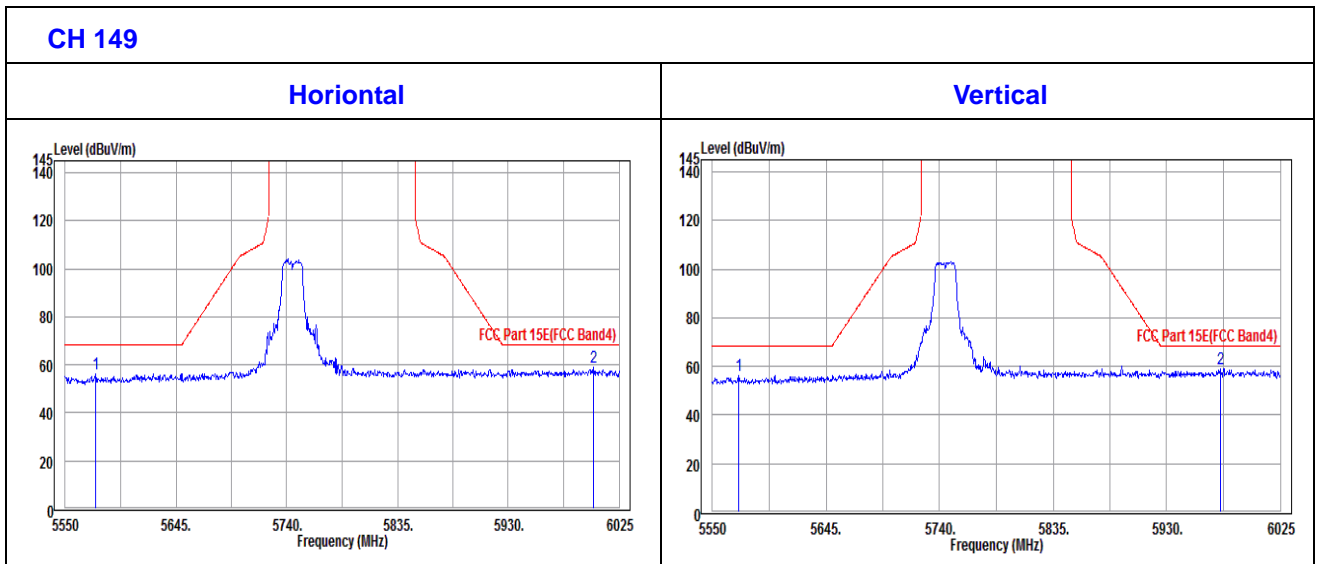



**BUREAU
VERITAS**

Test Report No.: RF170829W003-3

CHANNEL	TX Channel 157	DETECTOR FUNCTION	Peak (PK)
FREQUENCY RANGE	1GHz ~ 40GHz		Average (AV)

ANTENNA POLARITY & TEST DISTANCE: HORIZONTAL AT 3 M										
FREQ. (MHz)	EMISSION LEVEL (dBuV/m)	READ LEVEL (dBuV)	LIMIT (dBuV/m)	MARGIN (dB)	ANTENNA FACTOR (dB /m)	CABLE LOSS (dB)	PREAMP FACTOR (dB)	ANTENNA HEIGHT (cm)	TABLE ANGLE (Degree)	REMARK
5785	93.78	88.25			35.24	16.57	46.28	100	78	Average
5785	104.38	98.85			35.24	16.57	46.28	100	78	Peak
ANTENNA POLARITY & TEST DISTANCE: VERTICAL AT 3 M										
FREQ. (MHz)	EMISSION LEVEL (dBuV/m)	READ LEVEL (dBuV)	LIMIT (dBuV/m)	MARGIN (dB)	ANTENNA FACTOR (dB /m)	CABLE LOSS (dB)	PREAMP FACTOR (dB)	ANTENNA HEIGHT (cm)	TABLE ANGLE (Degree)	REMARK
5785	94.28	88.75			35.24	16.57	46.28	100	122	Average
5785	103.68	98.15			35.24	16.57	46.28	100	122	Peak

REMARKS:

1. Emission Level = Read Level+ Antenna Factor + Cable Loss- Preamp Factor
Margin value = Emission level – Limit value.
2. 5785MHz: Fundamental frequency.



Oobe DATA

802.11a

ANTENNA POLARITY & TEST DISTANCE: HORIZONTAL AT 3 M										
FREQ. (MHz)	EMISSION LEVEL (dBuV/m)	READ LEVEL (dBuV)	LIMIT (dBuV/m)	MARGIN (dB)	ANTENNA FACTOR (dB /m)	CABLE LOSS (dB)	PREAMP FACTOR (dB)	ANTENNA HEIGHT (cm)	TABLE ANGLE (Degree)	REMARK
5637.88	57.84	53.44	68.3	-10.46	35.07	15.61	46.28	100	78	Peak
5994.13	60.71	53.57	68.3	-7.59	35.49	17.93	46.28	100	78	Peak
ANTENNA POLARITY & TEST DISTANCE: VERTICAL AT 3 M										
FREQ. (MHz)	EMISSION LEVEL (dBuV/m)	READ LEVEL (dBuV)	LIMIT (dBuV/m)	MARGIN (dB)	ANTENNA FACTOR (dB /m)	CABLE LOSS (dB)	PREAMP FACTOR (dB)	ANTENNA HEIGHT (cm)	TABLE ANGLE (Degree)	REMARK
5596.08	57.74	53.66	68.3	-10.56	35.02	15.34	46.28	100	122	Peak
5992.7	59.92	52.79	68.3	-8.38	35.49	17.92	46.28	100	122	Peak

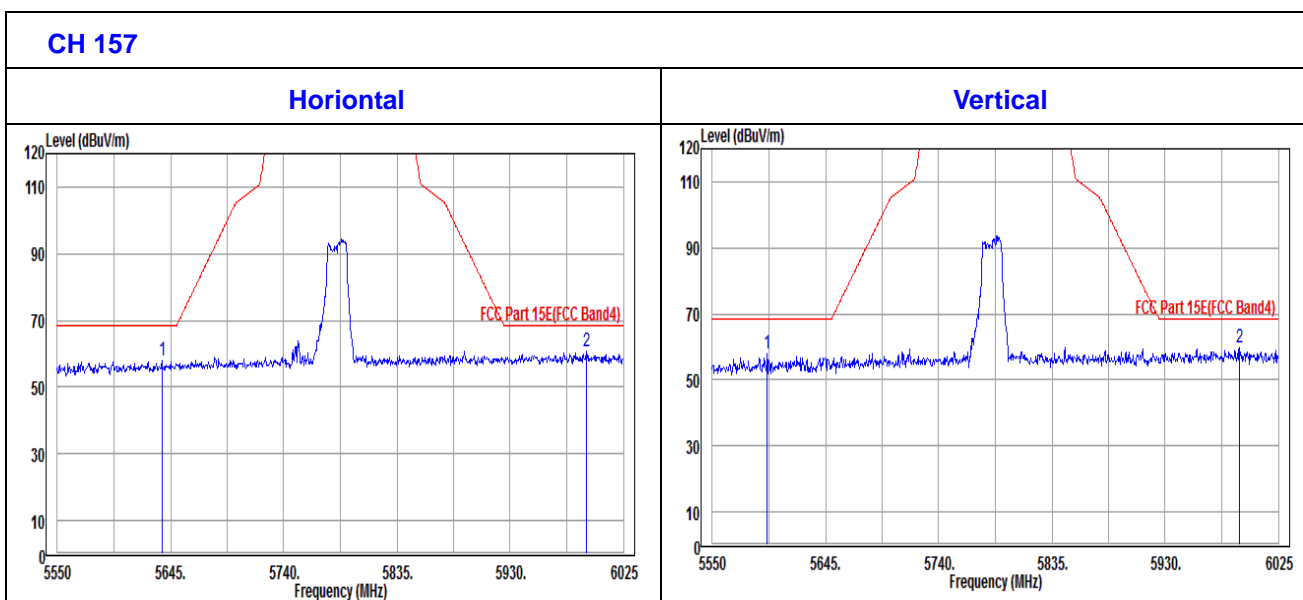



CHANNEL	TX Channel 165	DETECTOR FUNCTION	Peak (PK)
FREQUENCY RANGE	1GHz ~ 40GHz		Average (AV)

ANTENNA POLARITY & TEST DISTANCE: HORIZONTAL AT 3 M										
FREQ. (MHz)	EMISSION LEVEL (dBuV/m)	READ LEVEL (dBuV)	LIMIT (dBuV/m)	MARGIN (dB)	ANTENNA FACTOR (dB /m)	CABLE LOSS (dB)	PREAMP FACTOR (dB)	ANTENNA HEIGHT (cm)	TABLE ANGLE (Degree)	REMARK
5825	95.57	89.73			35.29	16.83	46.28	100	311	Average
5825	106.17	100.33			35.29	16.83	46.28	100	311	Peak
ANTENNA POLARITY & TEST DISTANCE: VERTICAL AT 3 M										
FREQ. (MHz)	EMISSION LEVEL (dBuV/m)	READ LEVEL (dBuV)	LIMIT (dBuV/m)	MARGIN (dB)	ANTENNA FACTOR (dB /m)	CABLE LOSS (dB)	PREAMP FACTOR (dB)	ANTENNA HEIGHT (cm)	TABLE ANGLE (Degree)	REMARK
5825	95.16	89.32			35.29	16.83	46.28	100	211	Average
5825	105.25	99.41			35.29	16.83	46.28	100	211	Peak

REMARKS:

1. Emission Level = Read Level+ Antenna Factor + Cable Loss- Preamp Factor
Margin value = Emission level – Limit value.
2. 5825MHz: Fundamental frequency.



Oobe DATA

802.11a

ANTENNA POLARITY & TEST DISTANCE: HORIZONTAL AT 3 M										
FREQ. (MHz)	EMISSION LEVEL (dBuV/m)	READ LEVEL (dBuV)	LIMIT (dBuV/m)	MARGIN (dB)	ANTENNA FACTOR (dB /m)	CABLE LOSS (dB)	PREAMP FACTOR (dB)	ANTENNA HEIGHT (cm)	TABLE ANGLE (Degree)	REMARK
5554.28	58.52	54.77	68.3	-9.78	34.97	15.06	46.28	100	311	Peak
5949.95	61.67	54.87	68.3	-6.63	35.44	17.64	46.28	100	311	Peak
ANTENNA POLARITY & TEST DISTANCE: VERTICAL AT 3 M										
FREQ. (MHz)	EMISSION LEVEL (dBuV/m)	READ LEVEL (dBuV)	LIMIT (dBuV/m)	MARGIN (dB)	ANTENNA FACTOR (dB /m)	CABLE LOSS (dB)	PREAMP FACTOR (dB)	ANTENNA HEIGHT (cm)	TABLE ANGLE (Degree)	REMARK
5638.35	58.05	53.65	68.3	-10.25	35.07	15.61	46.28	100	211	Peak
5999.83	60.85	53.66	68.3	-7.45	35.5	17.97	46.28	100	211	Peak

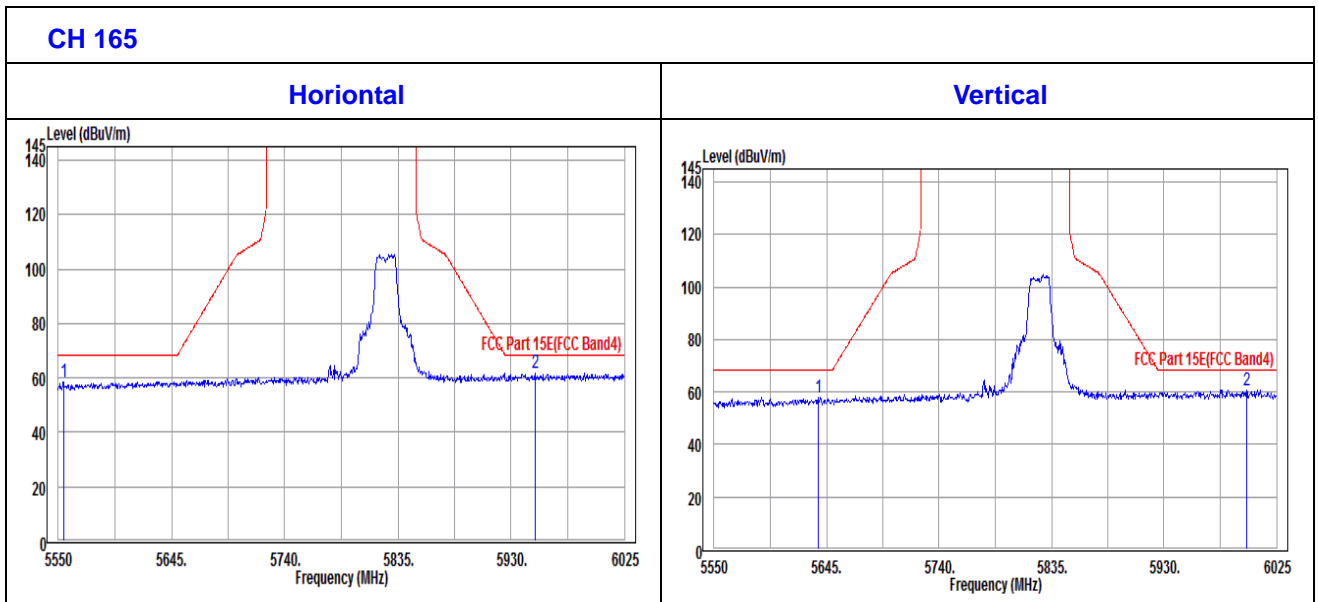



802.11n (20MHz)

CHANNEL	TX Channel 149	DETECTOR FUNCTION	Peak (PK)
FREQUENCY RANGE	1GHz ~ 40GHz		Average (AV)

ANTENNA POLARITY & TEST DISTANCE: HORIZONTAL AT 3 M										
FREQ. (MHz)	EMISSION LEVEL (dBuV/m)	READ LEVEL (dBuV)	LIMIT (dBuV/m)	MARGIN (dB)	ANTENNA FACTOR (dB /m)	CABLE LOSS (dB)	PREAMP FACTOR (dB)	ANTENNA HEIGHT (cm)	TABLE ANGLE (Degree)	REMARK
5745	93.29	88.07			35.19	16.31	46.28	100	164	Average
5745	103.68	98.46			35.19	16.31	46.28	100	164	Peak
ANTENNA POLARITY & TEST DISTANCE: VERTICAL AT 3 M										
FREQ. (MHz)	EMISSION LEVEL (dBuV/m)	READ LEVEL (dBuV)	LIMIT (dBuV/m)	MARGIN (dB)	ANTENNA FACTOR (dB /m)	CABLE LOSS (dB)	PREAMP FACTOR (dB)	ANTENNA HEIGHT (cm)	TABLE ANGLE (Degree)	REMARK
5745	94.27	89.05			35.19	16.31	46.28	102	80	Average
5745	104.2	98.98			35.19	16.31	46.28	102	80	Peak

REMARKS:

1. Emission Level = Read Level+ Antenna Factor + Cable Loss- Preamp Factor
Margin value = Emission level – Limit value.
2. 5745MHz: Fundamental frequency.



Oobe DATA

802.11n (20MHZ)

ANTENNA POLARITY & TEST DISTANCE: HORIZONTAL AT 3 M										
FREQ. (MHz)	EMISSION LEVEL (dBuV/m)	READ LEVEL (dBuV)	LIMIT (dBuV/m)	MARGIN (dB)	ANTENNA FACTOR (dB /m)	CABLE LOSS (dB)	PREAMP FACTOR (dB)	ANTENNA HEIGHT (cm)	TABLE ANGLE (Degree)	REMARK
5649.28	57.01	52.53	68.3	-11.29	35.08	15.68	46.28	100	164	Peak
6003.63	58.7	51.53	68.3	-9.6	35.5	17.95	46.28	100	164	Peak
ANTENNA POLARITY & TEST DISTANCE: VERTICAL AT 3 M										
FREQ. (MHz)	EMISSION LEVEL (dBuV/m)	READ LEVEL (dBuV)	LIMIT (dBuV/m)	MARGIN (dB)	ANTENNA FACTOR (dB /m)	CABLE LOSS (dB)	PREAMP FACTOR (dB)	ANTENNA HEIGHT (cm)	TABLE ANGLE (Degree)	REMARK
5643.58	56.33	51.89	68.3	-11.97	35.07	15.65	46.28	102	80	Peak
5945.2	60.18	53.42	68.3	-8.12	35.43	17.61	46.28	102	80	Peak

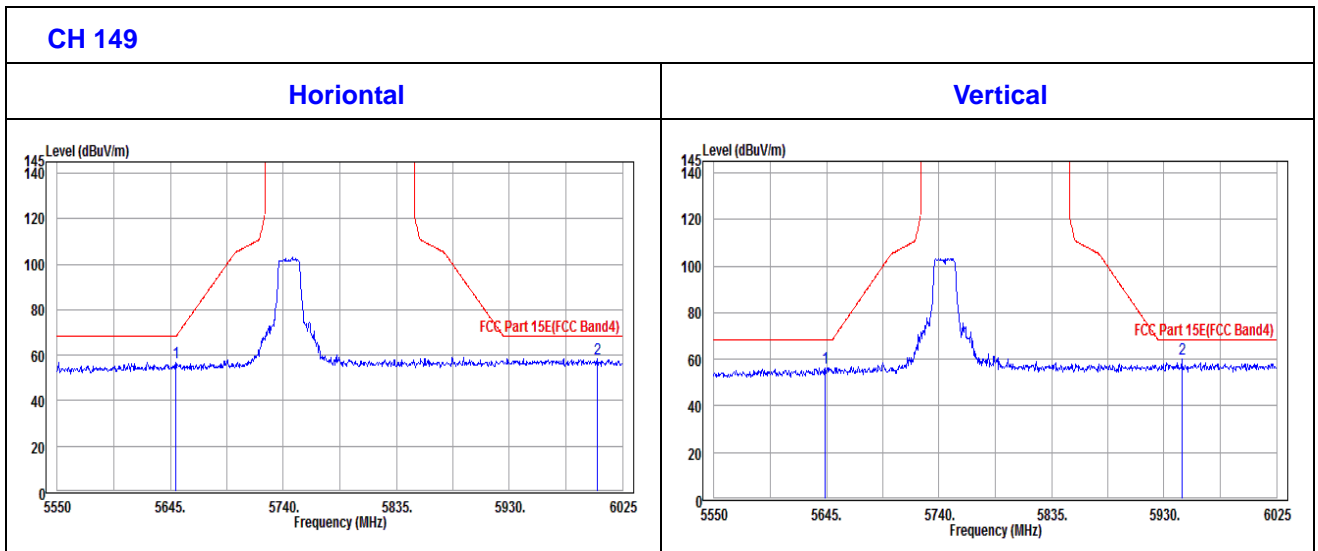



CHANNEL	TX Channel 157	DETECTOR FUNCTION	Peak (PK)
FREQUENCY RANGE	1GHz ~ 40GHz		Average (AV)

ANTENNA POLARITY & TEST DISTANCE: HORIZONTAL AT 3 M										
FREQ. (MHz)	EMISSION LEVEL (dBuV/m)	READ LEVEL (dBuV)	LIMIT (dBuV/m)	MARGIN (dB)	ANTENNA FACTOR (dB /m)	CABLE LOSS (dB)	PREAMP FACTOR (dB)	ANTENNA HEIGHT (cm)	TABLE ANGLE (Degree)	REMARK
5785	93.57	88.04			35.24	16.57	46.28	126	44	Average
5785	103.69	98.16			35.24	16.57	46.28	126	44	Peak

ANTENNA POLARITY & TEST DISTANCE: VERTICAL AT 3 M										
FREQ. (MHz)	EMISSION LEVEL (dBuV/m)	READ LEVEL (dBuV)	LIMIT (dBuV/m)	MARGIN (dB)	ANTENNA FACTOR (dB /m)	CABLE LOSS (dB)	PREAMP FACTOR (dB)	ANTENNA HEIGHT (cm)	TABLE ANGLE (Degree)	REMARK
5785	93.8	88.27			35.24	16.57	46.28	100	165	Average
5785	103.95	98.42			35.24	16.57	46.28	100	165	Peak

REMARKS:

1. Emission Level = Read Level+ Antenna Factor + Cable Loss- Preamp Factor
Margin value = Emission level – Limit value.
2. 5785MHz: Fundamental frequency.



OUBE DATA

802.11n (20MHZ)

ANTENNA POLARITY & TEST DISTANCE: HORIZONTAL AT 3 M										
FREQ. (MHz)	EMISSION LEVEL (dBuV/m)	READ LEVEL (dBuV)	LIMIT (dBuV/m)	MARGIN (dB)	ANTENNA FACTOR (dB /m)	CABLE LOSS (dB)	PREAMP FACTOR (dB)	ANTENNA HEIGHT (cm)	TABLE ANGLE (Degree)	REMARK
5622.68	56.47	52.19	68.3	-11.83	35.05	15.51	46.28	126	44	Peak
5949.95	59.52	52.72	68.3	-8.78	35.44	17.64	46.28	126	44	Peak
ANTENNA POLARITY & TEST DISTANCE: VERTICAL AT 3 M										
FREQ. (MHz)	EMISSION LEVEL (dBuV/m)	READ LEVEL (dBuV)	LIMIT (dBuV/m)	MARGIN (dB)	ANTENNA FACTOR (dB /m)	CABLE LOSS (dB)	PREAMP FACTOR (dB)	ANTENNA HEIGHT (cm)	TABLE ANGLE (Degree)	REMARK
5603.68	55.99	51.86	68.3	-12.31	35.02	15.39	46.28	100	165	Peak
5963.25	59.6	52.69	68.3	-8.7	35.46	17.73	46.28	100	165	Peak

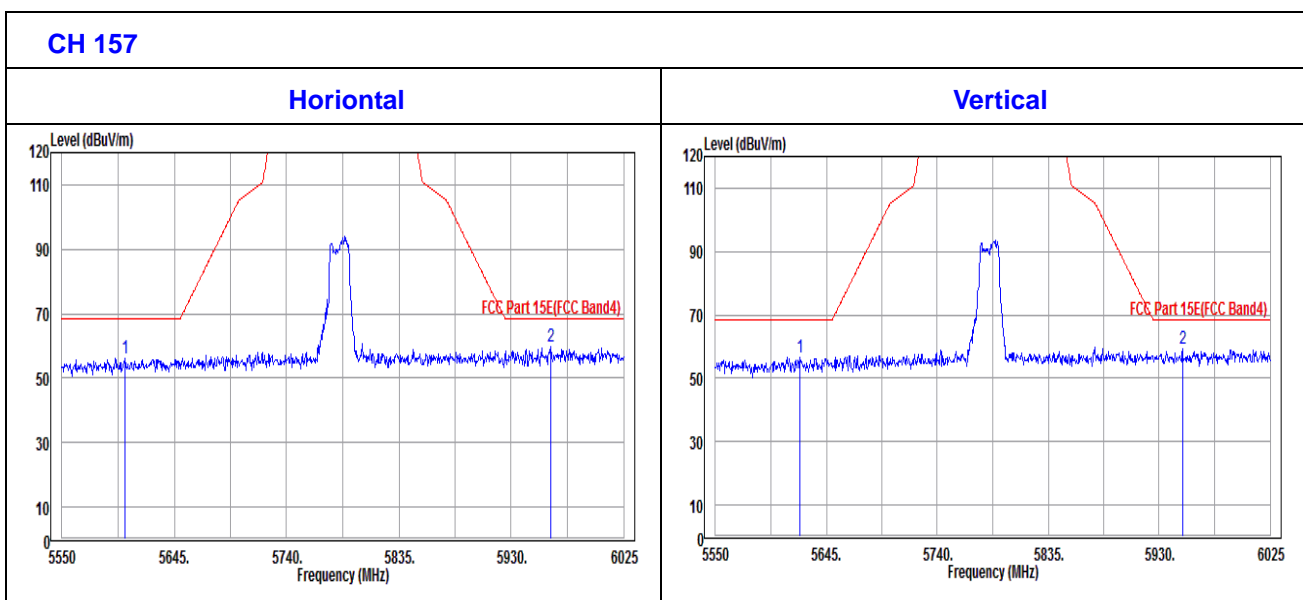



CHANNEL	TX Channel 165	DETECTOR FUNCTION	Peak (PK)
FREQUENCY RANGE	1GHz ~ 40GHz		Average (AV)

ANTENNA POLARITY & TEST DISTANCE: HORIZONTAL AT 3 M										
FREQ. (MHz)	EMISSION LEVEL (dBuV/m)	READ LEVEL (dBuV)	LIMIT (dBuV/m)	MARGIN (dB)	ANTENNA FACTOR (dB /m)	CABLE LOSS (dB)	PREAMP FACTOR (dB)	ANTENNA HEIGHT (cm)	TABLE ANGLE (Degree)	REMARK
5825	94	88.16			35.29	16.83	46.28	100	132	Average
5825	103.76	97.92			35.29	16.83	46.28	100	132	Peak
ANTENNA POLARITY & TEST DISTANCE: VERTICAL AT 3 M										
FREQ. (MHz)	EMISSION LEVEL (dBuV/m)	READ LEVEL (dBuV)	LIMIT (dBuV/m)	MARGIN (dB)	ANTENNA FACTOR (dB /m)	CABLE LOSS (dB)	PREAMP FACTOR (dB)	ANTENNA HEIGHT (cm)	TABLE ANGLE (Degree)	REMARK
5825	93.41	87.57			35.29	16.83	46.28	100	80	Average
5825	103.49	97.65			35.29	16.83	46.28	100	80	Peak

REMARKS:

1. Emission Level = Read Level+ Antenna Factor + Cable Loss- Preamp Factor
Margin value = Emission level – Limit value.
2. 5825MHz: Fundamental frequency.



OUBE DATA

802.11n (20MHZ)

ANTENNA POLARITY & TEST DISTANCE: HORIZONTAL AT 3 M										
FREQ. (MHz)	EMISSION LEVEL (dBuV/m)	READ LEVEL (dBuV)	LIMIT (dBuV/m)	MARGIN (dB)	ANTENNA FACTOR (dB /m)	CABLE LOSS (dB)	PREAMP FACTOR (dB)	ANTENNA HEIGHT (cm)	TABLE ANGLE (Degree)	REMARK
5631.23	56	51.65	68.3	-12.3	35.06	15.57	46.28	100	132	Peak
5965.63	58.25	51.32	68.3	-10.05	35.46	17.75	46.28	100	132	Peak
ANTENNA POLARITY & TEST DISTANCE: VERTICAL AT 3 M										
FREQ. (MHz)	EMISSION LEVEL (dBuV/m)	READ LEVEL (dBuV)	LIMIT (dBuV/m)	MARGIN (dB)	ANTENNA FACTOR (dB /m)	CABLE LOSS (dB)	PREAMP FACTOR (dB)	ANTENNA HEIGHT (cm)	TABLE ANGLE (Degree)	REMARK
5640.73	56	51.58	68.3	-12.3	35.07	15.63	46.28	100	80	Peak
5948.53	59.55	52.76	68.3	-8.75	35.44	17.63	46.28	100	80	Peak

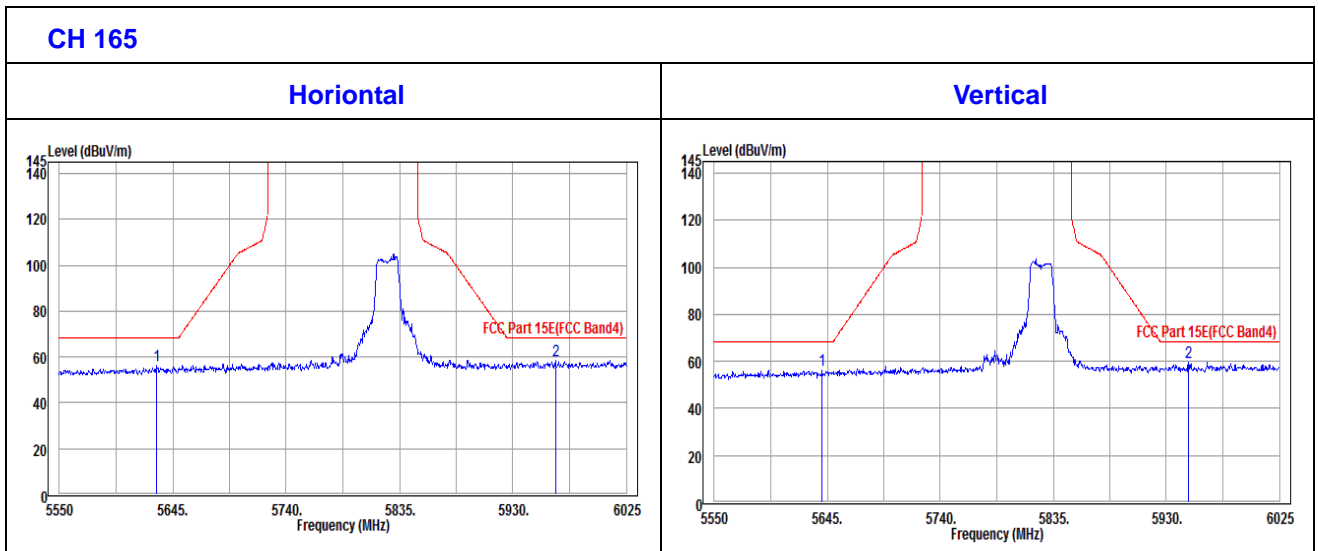



802.11n (40MHz)

CHANNEL	TX Channel 151	DETECTOR FUNCTION	Peak (PK)
FREQUENCY RANGE	1GHz ~ 40GHz		Average (AV)

ANTENNA POLARITY & TEST DISTANCE: HORIZONTAL AT 3 M										
FREQ. (MHz)	EMISSION LEVEL (dBuV/m)	READ LEVEL (dBuV)	LIMIT (dBuV/m)	MARGIN (dB)	ANTENNA FACTOR (dB /m)	CABLE LOSS (dB)	PREAMP FACTOR (dB)	ANTENNA HEIGHT (cm)	TABLE ANGLE (Degree)	REMARK
5755	89.12	83.82			35.21	16.37	46.28	100	142	Average
5755	99.22	93.92			35.21	16.37	46.28	100	142	Peak
ANTENNA POLARITY & TEST DISTANCE: VERTICAL AT 3 M										
FREQ. (MHz)	EMISSION LEVEL (dBuV/m)	READ LEVEL (dBuV)	LIMIT (dBuV/m)	MARGIN (dB)	ANTENNA FACTOR (dB /m)	CABLE LOSS (dB)	PREAMP FACTOR (dB)	ANTENNA HEIGHT (cm)	TABLE ANGLE (Degree)	REMARK
5755	89.55	84.25			35.21	16.37	46.28	103	81	Average
5755	99.39	94.09			35.21	16.37	46.28	103	81	Peak

REMARKS:

1. Emission Level = Read Level+ Antenna Factor + Cable Loss- Preamp Factor
Margin value = Emission level – Limit value.
2. 5755MHz: Fundamental frequency.



OOBE DATA

802.11n (40MHZ)

ANTENNA POLARITY & TEST DISTANCE: HORIZONTAL AT 3 M										
FREQ. (MHz)	EMISSION LEVEL (dBuV/m)	READ LEVEL (dBuV)	LIMIT (dBuV/m)	MARGIN (dB)	ANTENNA FACTOR (dB /m)	CABLE LOSS (dB)	PREAMP FACTOR (dB)	ANTENNA HEIGHT (cm)	TABLE ANGLE (Degree)	REMARK
5634.55	55.79	51.42	68.3	-12.51	35.06	15.59	46.28	100	142	Peak
5983.2	58.02	50.96	68.3	-10.28	35.48	17.86	46.28	100	142	Peak
ANTENNA POLARITY & TEST DISTANCE: VERTICAL AT 3 M										
FREQ. (MHz)	EMISSION LEVEL (dBuV/m)	READ LEVEL (dBuV)	LIMIT (dBuV/m)	MARGIN (dB)	ANTENNA FACTOR (dB /m)	CABLE LOSS (dB)	PREAMP FACTOR (dB)	ANTENNA HEIGHT (cm)	TABLE ANGLE (Degree)	REMARK
5645.95	56.36	51.9	68.3	-11.94	35.08	15.66	46.28	103	81	Peak
5961.35	58.53	51.64	68.3	-9.77	35.45	17.72	46.28	103	81	Peak

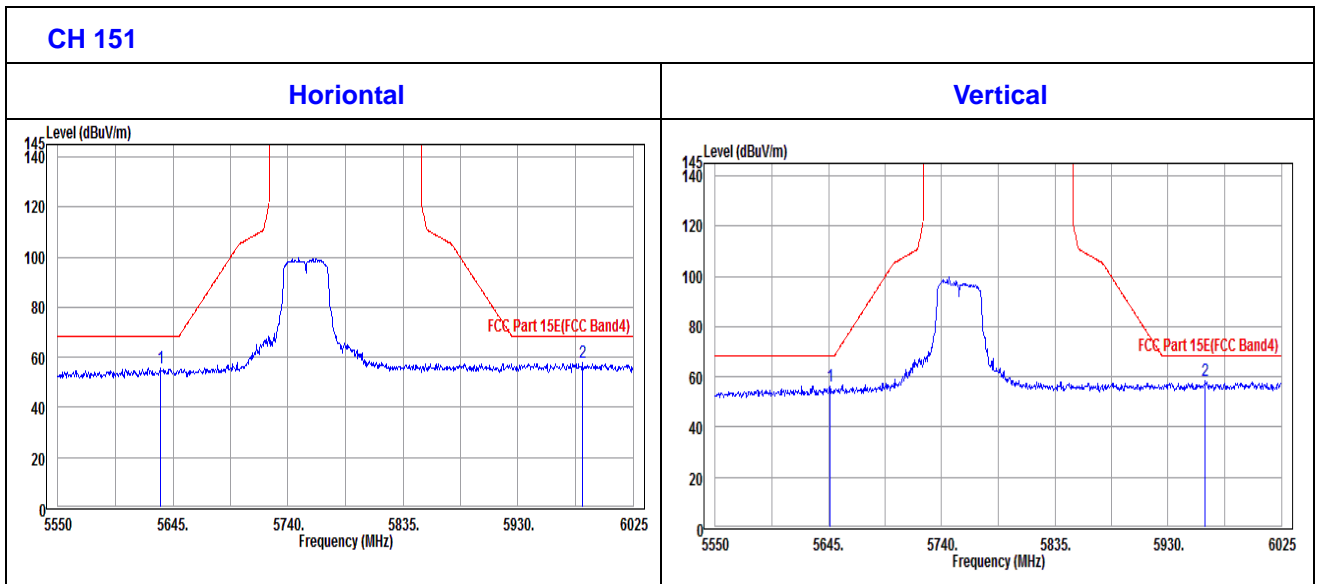



CHANNEL	TX Channel 159	DETECTOR FUNCTION	Peak (PK)
FREQUENCY RANGE	1GHz ~ 40GHz		Average (AV)

ANTENNA POLARITY & TEST DISTANCE: HORIZONTAL AT 3 M										
FREQ. (MHz)	EMISSION LEVEL (dBuV/m)	READ LEVEL (dBuV)	LIMIT (dBuV/m)	MARGIN (dB)	ANTENNA FACTOR (dB /m)	CABLE LOSS (dB)	PREAMP FACTOR (dB)	ANTENNA HEIGHT (cm)	TABLE ANGLE (Degree)	REMARK
5795	90.33	84.73			35.25	16.63	46.28	112	155	Average
5795	101.08	95.48			35.25	16.63	46.28	112	155	Peak

ANTENNA POLARITY & TEST DISTANCE: VERTICAL AT 3 M										
FREQ. (MHz)	EMISSION LEVEL (dBuV/m)	READ LEVEL (dBuV)	LIMIT (dBuV/m)	MARGIN (dB)	ANTENNA FACTOR (dB /m)	CABLE LOSS (dB)	PREAMP FACTOR (dB)	ANTENNA HEIGHT (cm)	TABLE ANGLE (Degree)	REMARK
5795	88.82	83.22			35.25	16.63	46.28	102	81	Average
5795	100.16	94.56			35.25	16.63	46.28	102	81	Peak

REMARKS:

1. Emission Level = Read Level+ Antenna Factor + Cable Loss- Preamp Factor
Margin value = Emission level – Limit value.
2. 5795MHz: Fundamental frequency.



OOBE DATA

802.11n (40MHZ)

ANTENNA POLARITY & TEST DISTANCE: HORIZONTAL AT 3 M										
FREQ. (MHz)	EMISSION LEVEL (dBuV/m)	READ LEVEL (dBuV)	LIMIT (dBuV/m)	MARGIN (dB)	ANTENNA FACTOR (dB /m)	CABLE LOSS (dB)	PREAMP FACTOR (dB)	ANTENNA HEIGHT (cm)	TABLE ANGLE (Degree)	REMARK
5628.38	55.59	51.27	68.3	-12.71	35.05	15.55	46.28	112	155	Peak
5977.98	58.47	51.45	68.3	-9.83	35.47	17.83	46.28	112	155	Peak
ANTENNA POLARITY & TEST DISTANCE: VERTICAL AT 3 M										
FREQ. (MHz)	EMISSION LEVEL (dBuV/m)	READ LEVEL (dBuV)	LIMIT (dBuV/m)	MARGIN (dB)	ANTENNA FACTOR (dB /m)	CABLE LOSS (dB)	PREAMP FACTOR (dB)	ANTENNA HEIGHT (cm)	TABLE ANGLE (Degree)	REMARK
5621.25	55.89	51.62	68.3	-12.41	35.05	15.5	46.28	102	81	Peak
5966.1	58.83	51.9	68.3	-9.47	35.46	17.75	46.28	102	81	Peak

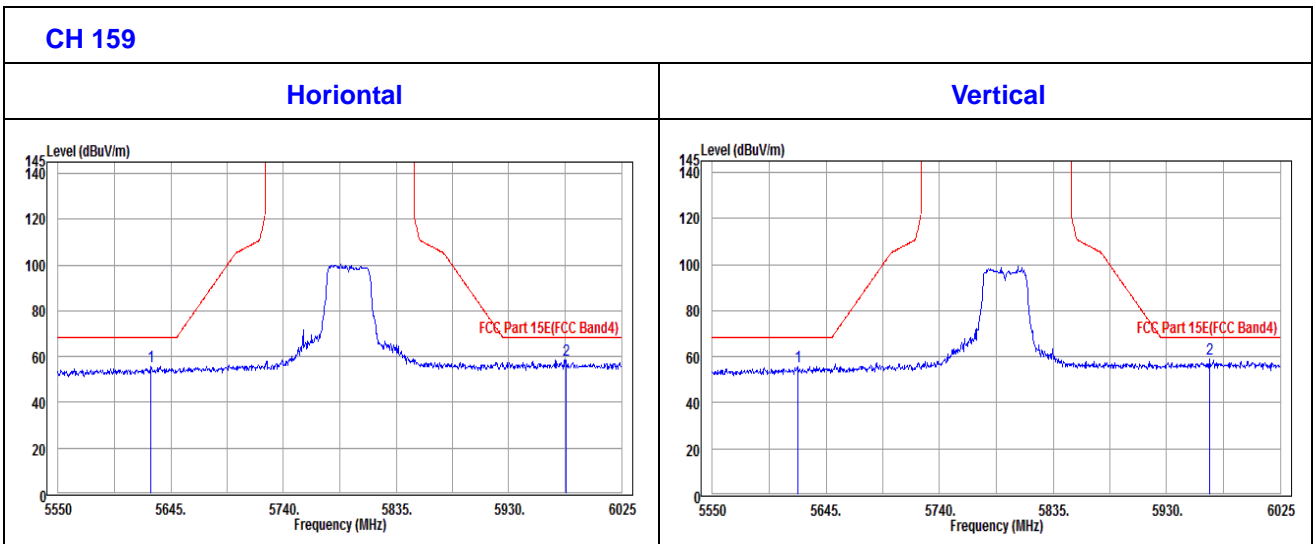

4.2 CONDUCTED EMISSION MEASUREMENT

4.2.1 LIMITS OF CONDUCTED EMISSION MEASUREMENT

FREQUENCY OF EMISSION (MHz)	CONDUCTED LIMIT (dB μ V)	
	Quasi-peak	Average
0.15 ~ 0.5	66 to 56	56 to 46
0.5 ~ 5	56	46
5 ~ 30	60	50

NOTE: 1. The lower limit shall apply at the transition frequencies.

2. The limit decreases in line with the logarithm of the frequency in the range of 0.15 to 0.50MHz.

3. All emanations from a class A/B digital device or system, including any network of conductors and apparatus connected thereto, shall not exceed the level of field strengths specified above.

4.2.2 TEST INSTRUMENTS

Equipment	Manufacturer	Model No.	Serial No.	Last Cal.	Next Cal.
EMI Test Receiver	Rohde&Schwarz	ESR3	101900	Jun. 28,17	Jun. 27,18
EMC32 test software	Rohde&Schwarz	EMC32	NA	NA	NA
LISN network	Rohde&Schwarz	ENV216	101922	Sep. 18,17	Sep. 17,18

NOTE:

1. The test was performed in CE shielded room.

2. The calibration interval of the above test instruments is 12 months. And the calibrations are traceable to CEPREI/CHINA, GRGT/CHINA and NIM/CHINA.

4.2.3 TEST PROCEDURES

- The EUT was placed 0.4 meters from the conducting wall of the shielded room with EUT being connected to the power mains through a line impedance stabilization network (LISN). Other support units were connected to the power mains through another LISN. The two LISNs provide 50 ohm/ 50uH of coupling impedance for the measuring instrument.
- Both lines of the power mains connected to the EUT were checked for maximum conducted interference.
- The frequency range from 150kHz to 30MHz was searched. Emission levels under (Limit - 20dB) was not recorded.

NOTE: All modes of operation were investigated and the worst-case emissions are reported.

4.2.4 DEVIATION FROM TEST STANDARD

No deviation.

4.2.5 TEST SETUP

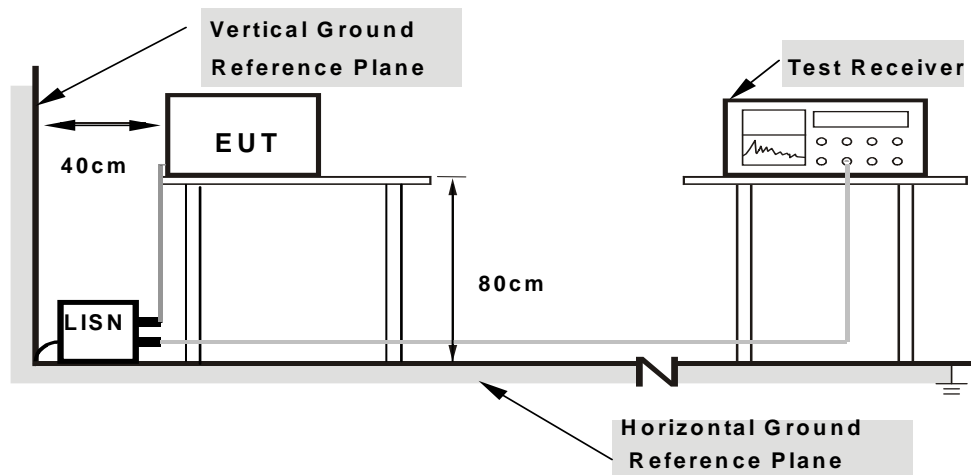

- Note:**
- 1.Support units were connected to second LISN.
 - 2.Both of LISNs (AMN) are 80 cm from EUT and at least 80 from other units and other metal planes

For the actual test configuration, please refer to the attached file (Test Setup Photo).

4.2.6 EUT OPERATING CONDITIONS

Same as 4.1.6.

4.2.7 TEST RESULTS

CONDUCTED WORST-CASE DATA :

Frequency Range	150KHz ~ 30MHz	Detector Function & Resolution Bandwidth	Quasi-Peak (QP) / Average (AV), 9 kHz
Input Power	120Vac, 60Hz	Environmental Conditions	24deg. C, 55RH
Tested By	Jocan Guo	TEST DATE	2017/10/10

Frequency (MHz)	QuasiPeak (dB μ V)	CAverage (dB μ V)	Limit (dB μ V)	Margin (dB)	Line	Filter	Corr. (dB)
0.150000	---	27.68	56.00	-28.32	L	ON	9.6
0.150000	42.72	---	66.00	-23.28	L	ON	9.6
0.196000	---	30.30	53.78	-23.48	L	ON	9.7
0.196000	43.68	---	63.78	-20.10	L	ON	9.7
0.584000	---	26.22	46.00	-19.78	L	ON	9.7
0.584000	38.09	---	56.00	-17.91	L	ON	9.7
1.368000	---	22.35	46.00	-23.65	L	ON	9.7
1.368000	30.96	---	56.00	-25.04	L	ON	9.7
3.060000	---	24.48	46.00	-21.52	L	ON	9.7
3.060000	35.07	---	56.00	-20.93	L	ON	9.7
4.252000	---	24.20	46.00	-21.80	L	ON	9.7
4.252000	32.60	---	56.00	-23.40	L	ON	9.7

- REMARKS:**
1. Q.P. and AV. are abbreviations of quasi-peak and average individually.
 2. "-": The Quasi-peak reading value also meets average limit and measurement with the average detector is unnecessary.
 3. The emission levels of other frequencies were very low against the limit.
 4. Margin value = Emission level - Limit value
 5. Correction factor = Insertion loss + Cable loss
 6. Emission Level = Correction Factor + Reading Value.

Full Spectrum

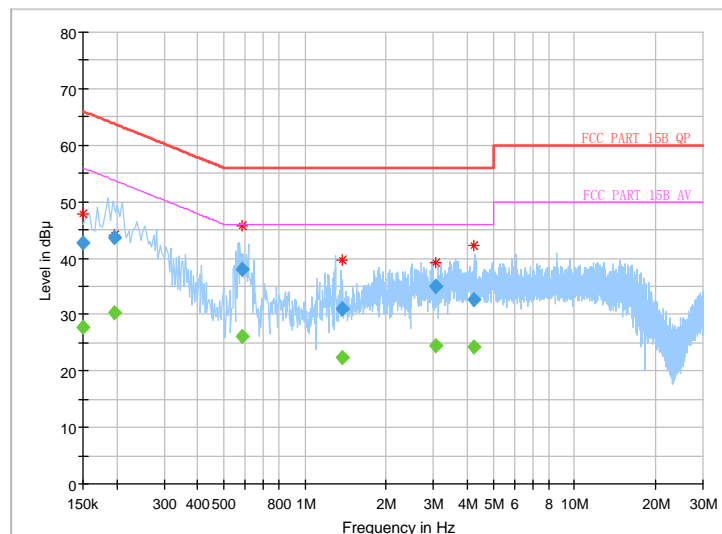

Frequency Range	150KHz ~ 30MHz	Detector Function & Resolution Bandwidth	Quasi-Peak (QP) / Average (AV), 9 kHz
Input Power	120Vac, 60Hz	Environmental Conditions	24deg. C, 55RH
Tested By	Jocan Guo	TEST DATE	2017/10/10

Frequency (MHz)	QuasiPeak (dBµV)	CAverage (dBµV)	Limit (dBµV)	Margin (dB)	Line	Filter	Corr. (dB)
0.150000	---	30.80	56.00	-25.20	N	ON	9.8
0.150000	45.29	---	66.00	-20.71	N	ON	9.8
0.200000	---	35.00	53.61	-18.61	N	ON	9.9
0.200000	47.64	---	63.61	-15.97	N	ON	9.9
0.584000	---	35.35	46.00	-10.65	N	ON	10.1
0.584000	47.28	---	56.00	-8.72	N	ON	10.1
1.144000	---	27.35	46.00	-18.65	N	ON	9.9
1.144000	38.34	---	56.00	-17.66	N	ON	9.9
3.472000	---	28.51	46.00	-17.49	N	ON	9.8
3.472000	38.35	---	56.00	-17.65	N	ON	9.8
4.840000	---	28.75	46.00	-17.25	N	ON	9.8
4.840000	39.11	---	56.00	-16.89	N	ON	9.8

- REMARKS:**
1. Q.P. and AV. are abbreviations of quasi-peak and average individually.
 2. "-": The Quasi-peak reading value also meets average limit and measurement with the average detector is unnecessary.
 3. The emission levels of other frequencies were very low against the limit.
 4. Margin value = Emission level - Limit value
 5. Correction factor = Insertion loss + Cable loss
 6. Emission Level = Correction Factor + Reading Value.

Full Spectrum

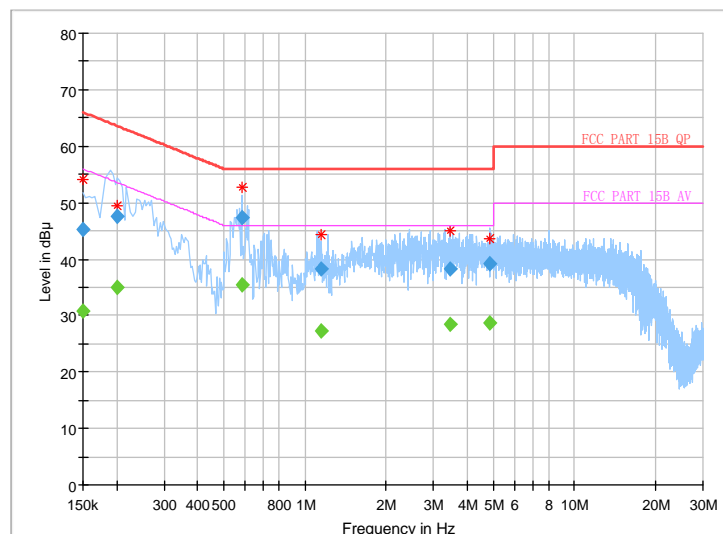

4.3 MAXIMUM CONDUCTED OUTPUT POWER MEASUREMENT

4.3.1 LIMITS OF MAXIMUM CONDUCTED OUTPUT POWER MEASUREMENT

Operation Band	EUT Category		LIMIT
U-NII-1		Outdoor Access Point	1 Watt (30 dBm) (Max. e.i.r.p \leq 125mW(21 dBm) at any elevation angle above 30 degrees as measured from the horizon)
		Fixed point-to-point Access Point	1 Watt (30 dBm)
		Indoor Access Point	1 Watt (30 dBm)
	√	Client devices	250mW (24 dBm)
U-NII-2A		√	250mW (24 dBm) or 11 dBm+10 log B*
U-NII-2C		√	250mW (24 dBm) or 11 dBm+10 log B*
U-NII-3		√	1 Watt (30 dBm)

NOTE: Where B is the 26dB emission bandwidth in MHz.

4.3.2 TEST SETUP

FOR POWER OUTPUT MEASUREMENT

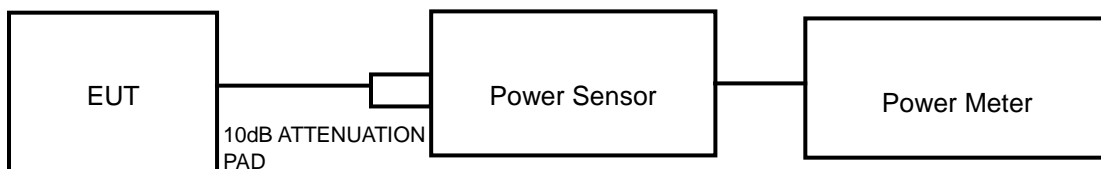

FOR 26dB BANDWIDTH

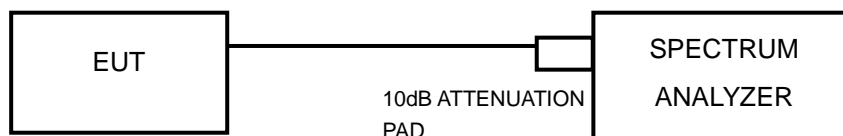

4.3.3 TEST INSTRUMENTS

Equipment	Manufacturer	Model No.	Serial No.	Last Cal.	Next Cal.
Power Meter	ANRITSU	ML2495A	1506002	Mar. 01,17	Feb. 28,18
EXA Signal Analyzer	KEYSIGHT	N9010A-526	MY54510523	Mar. 01,17	Feb. 28,18
EXA Signal Analyzer	KEYSIGHT	N9010A-544	MY54510332	Mar. 01,17	Feb. 28,18
Power Sensor	ANRITSU	MA2411B	1339352	Mar. 01,17	Feb. 28,18

NOTE:

1. The calibration interval of the above test instruments is 12 months and the calibrations are traceable to CEPREI/CHINA, GRGT/CHINA and NIM/CHINA.
2. The test was performed in RF Oven room.

4.3.4 TEST PROCEDURE

FOR POWER MEASUREMENT

Method PM is used to perform output power measurement, trigger and gating function of wide band power meter is enabled to measure max output power of TX on burst. Duty factor is not added to measured value.

FOR 99 PERCENT OCCUPIED BANDWIDTH

The following procedure shall be used for measuring (99 %) power bandwidth:

1. Set center frequency to the nominal EUT channel center frequency.
2. Set span = 1.5 times to 5.0 times the OBW.
3. Set RBW = 1 % to 5 % of the OBW
4. Set VBW $\geq 3 \cdot$ RBW
5. Video averaging is not permitted. Where practical, a sample detection and single sweep mode shall be used. Otherwise, peak detection and max hold mode (until the trace stabilizes) shall be used.
6. Use the 99 % power bandwidth function of the instrument (if available).
7. If the instrument does not have a 99 % power bandwidth function, the trace data points are recovered and directly summed in power units. The recovered amplitude data points, beginning at the lowest frequency, are placed in a running sum until 0.5 % of the total is reached; that frequency is recorded as the lower frequency. The process is repeated until 99.5 % of the total is reached; that frequency is recorded as the upper frequency. The 99% occupied bandwidth is the difference between these two frequencies.



FOR 26dB BANDWIDTH

- 1) Set RBW = approximately 1% of the emission bandwidth.
- 2) Set the VBW > RBW.
- 3) Detector = Peak.
- 4) Trace mode = max hold.
- 5) Measure the maximum width of the emission that is 26 dB down from the peak of the emission. Compare this with the RBW setting of the analyzer. Readjust RBW and repeat measurement as needed until the RBW/EBW ratio is approximately 1%.

FOR 6dB BANDWIDTH

1. Set RBW = 100 kHz.
2. Set the video bandwidth (VBW) ≥ 3 RBW.
3. Detector = Peak.
4. Trace mode = max hold.
5. Sweep = auto couple.
6. Allow the trace to stabilize.
7. Measure the maximum width of the emission that is constrained by the frequencies associated with the two outermost amplitude points (upper and lower frequencies) that are attenuated by 6 dB relative to the maximum level measured in the fundamental emission.

4.3.5 DEVIATION FROM TEST STANDARD

No deviation.

4.3.6 EUT OPERATING CONDITIONS

The software provided by client to enable the EUT under transmission condition continuously at specific channel frequencies individually.

4.3.7 TEST RESULTS

OUTPUT POWER:

802.11a

CHANNEL	CHANNEL FREQUENCY (MHz)	AVERAGE POWER (dBm)	AVERAGE POWER (mW)	POWER LIMIT (dBm)	PASS/FAIL
36	5180	13.68	23.335	24	PASS
40	5200	13.25	21.135	24	PASS
48	5240	13.42	21.979	24	PASS
52	5260	13.33	21.528	24	PASS
60	5300	13.19	20.845	24	PASS
64	5320	13.36	21.677	24	PASS
100	5500	12.42	17.458	24	PASS
116	5580	12.44	17.539	24	PASS
140	5700	12.48	17.701	24	PASS
149	5745	12.41	17.418	30	PASS
157	5785	12.47	17.660	30	PASS
165	5825	12.45	17.579	30	PASS

802.11n (20MHz)

CHANNEL	CHANNEL FREQUENCY (MHz)	AVERAGE POWER (dBm)	AVERAGE POWER (mW)	POWER LIMIT (dBm)	PASS/FAIL
36	5180	11.41	13.836	24	PASS
40	5200	11.36	13.677	24	PASS
48	5240	11.59	14.421	24	PASS
52	5260	11.85	15.311	24	PASS
60	5300	11.33	13.583	24	PASS
64	5320	11.47	14.028	24	PASS
100	5500	11.54	14.256	24	PASS
116	5580	11.41	13.836	24	PASS
140	5700	11.50	14.125	24	PASS
149	5745	11.38	13.740	30	PASS
157	5785	11.28	13.428	30	PASS
165	5825	11.31	13.521	30	PASS



802.11n (40MHz)

CHANNEL	CHANNEL FREQUENCY (MHz)	AVERAGE POWER (dBm)	AVERAGE POWER (mW)	POWER LIMIT (dBm)	PASS/FAIL
38	5190	11.50	14.125	24	PASS
46	5230	11.59	14.421	24	PASS
54	5270	11.37	13.709	24	PASS
62	5310	11.78	15.066	24	PASS
102	5510	11.15	13.032	24	PASS
110	5550	11.43	13.900	24	PASS
134	5670	11.76	14.997	24	PASS
151	5755	11.56	14.322	30	PASS
165	5825	11.62	14.521	30	PASS

99% OCCUPIED BANDWIDTH & 26dB BANDWIDTH/6dB BANDWIDTH:

802.11a

CHANNEL	CHANNEL FREQUENCY (MHz)	99% OCCUPIED BANDWIDTH	26dB BANDWIDTH (MHz)	PASS/FAIL
36	5180	17.40	33.02	PASS
40	5200	17.10	25.86	PASS
48	5240	17.16	34.21	PASS
52	5260	16.92	33.23	PASS
60	5300	17.52	35.06	PASS
64	5320	18.00	39.61	PASS
100	5500	17.04	33.58	PASS
116	5580	17.34	34.09	PASS
140	5700	17.70	33.37	PASS
CHANNEL	CHANNEL FREQUENCY (MHz)	99% OCCUPIED BANDWIDTH	6dB BANDWIDTH (MHz)	PASS/FAIL
149	5745	16.98	16.37	PASS
157	5785	16.98	16.39	PASS
165	5825	16.92	16.34	PASS



Test Report No.: RF170829W003-3

802.11n (20MHz)

CHANNEL	CHANNEL FREQUENCY (MHz)	99% OCCUPIED BANDWIDTH	26dB BANDWIDTH (MHz)	PASS/FAIL
36	5180	18.06	24.25	PASS
40	5200	18.12	25.53	PASS
48	5240	18.06	22.71	PASS
52	5260	18.12	23.48	PASS
60	5300	18.06	24.89	PASS
64	5320	18.24	32.91	PASS
100	5500	18.12	23.46	PASS
116	5580	18.06	23.43	PASS
140	5700	18.18	28.04	PASS
CHANNEL	CHANNEL FREQUENCY (MHz)	99% OCCUPIED BANDWIDTH	6dB BANDWIDTH (MHz)	PASS/FAIL
149	5745	18.12	17.59	PASS
157	5785	17.64	17.57	PASS
165	5825	18.00	17.58	PASS

802.11n (40MHz)

CHANNEL	CHANNEL FREQUENCY (MHz)	99% OCCUPIED BANDWIDTH	26dB BANDWIDTH (MHz)	PASS/FAIL
38	5190	36.54	58.94	PASS
46	5230	36.42	48.76	PASS
54	5270	36.48	44.83	PASS
62	5310	36.42	65.03	PASS
102	5510	36.42	46.58	PASS
110	5550	36.42	68.12	PASS
134	5670	36.42	73.71	PASS
CHANNEL	CHANNEL FREQUENCY (MHz)	99% OCCUPIED BANDWIDTH	6dB BANDWIDTH (MHz)	PASS/FAIL
151	5755	36.48	35.13	PASS
159	5795	36.42	35.19	PASS



For U-NII-1:

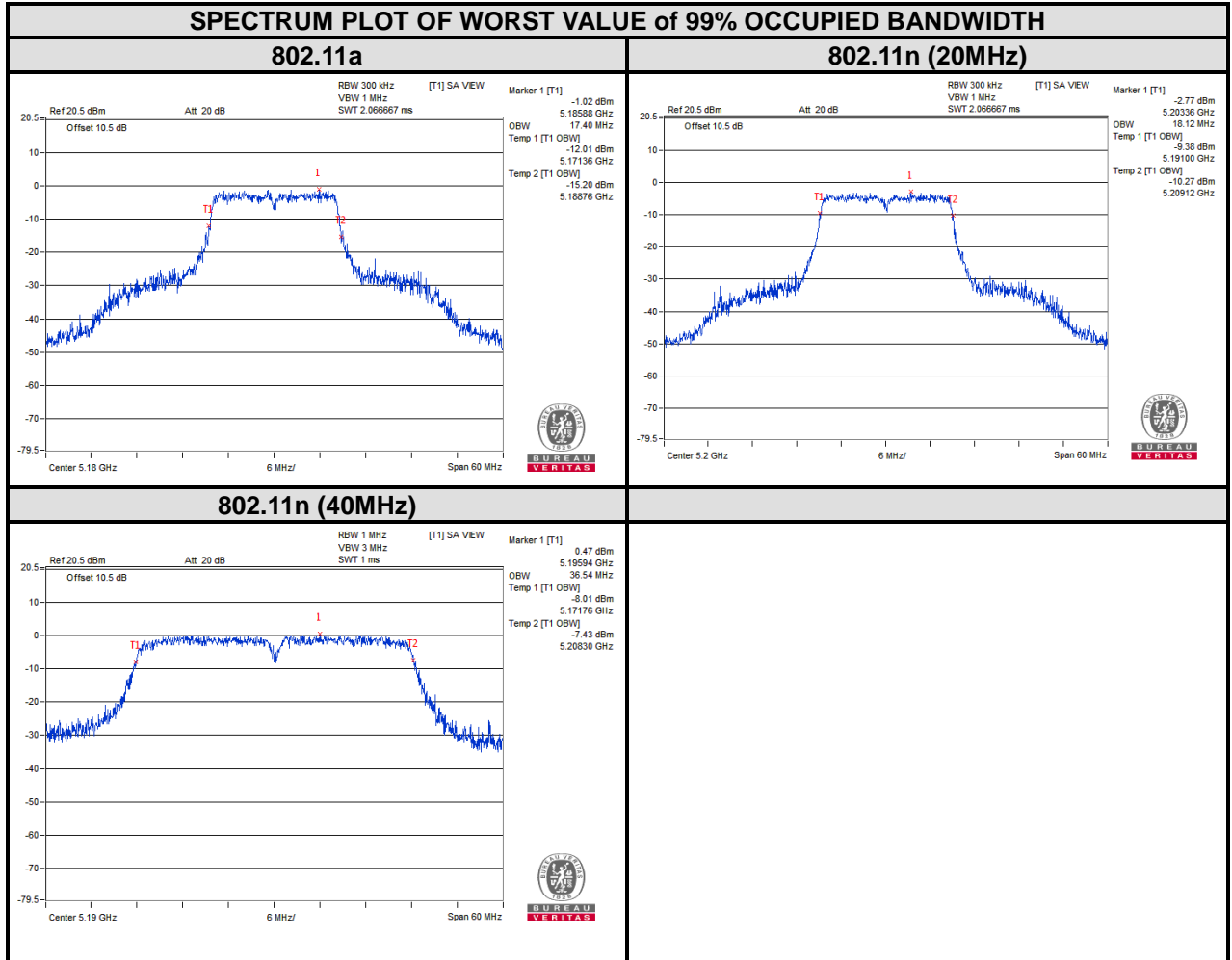

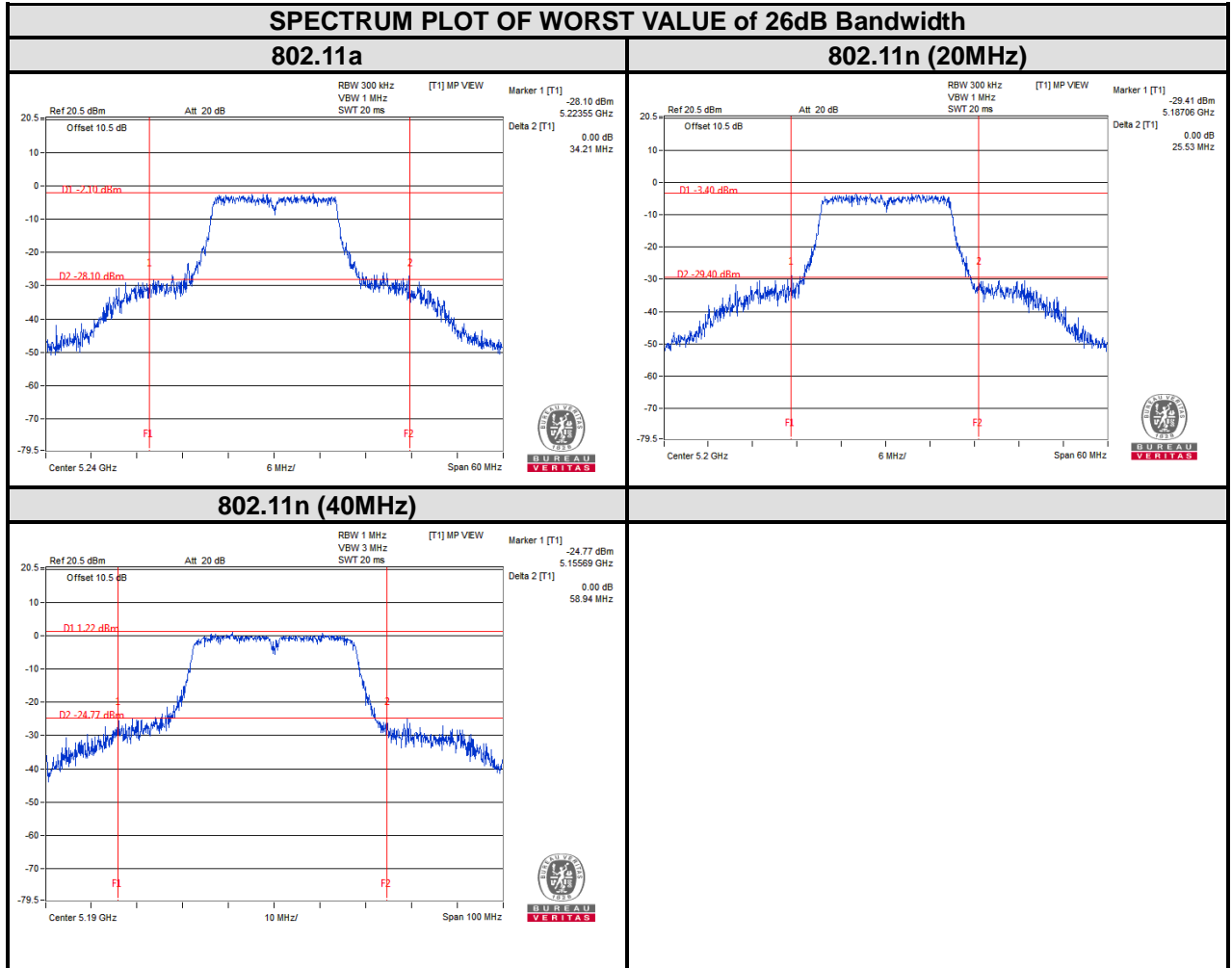



For U-NII-2A:

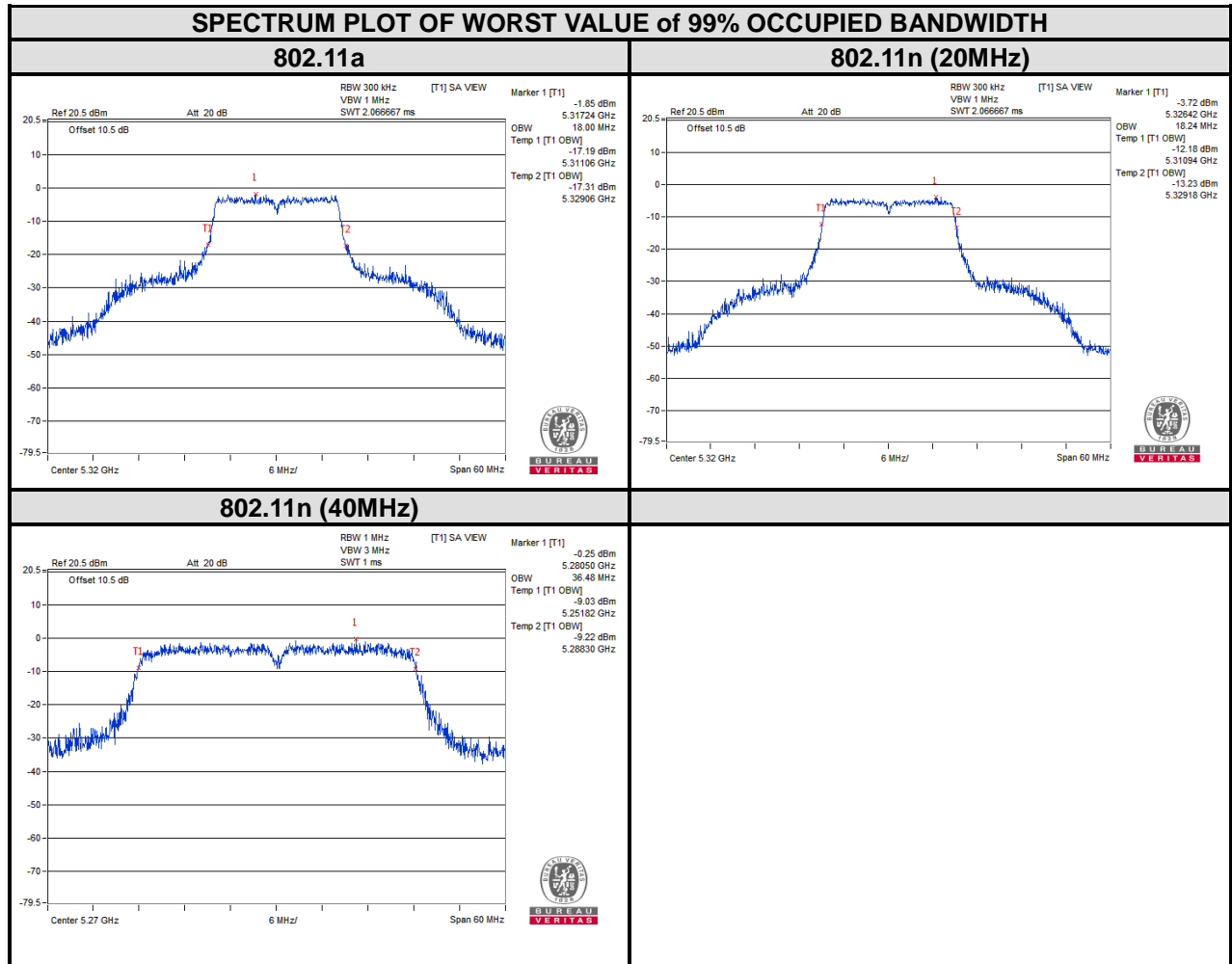

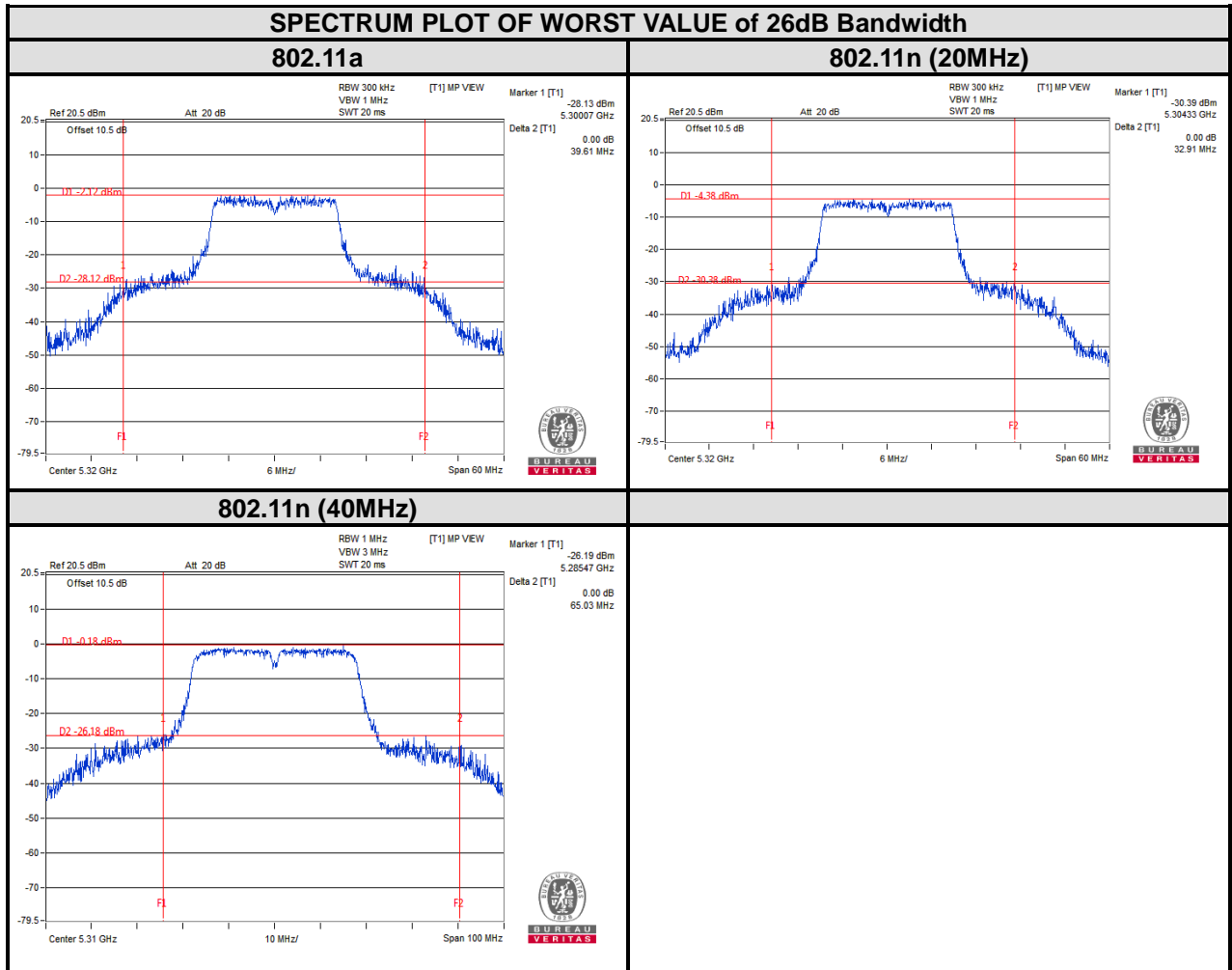



For U-NII-2C:

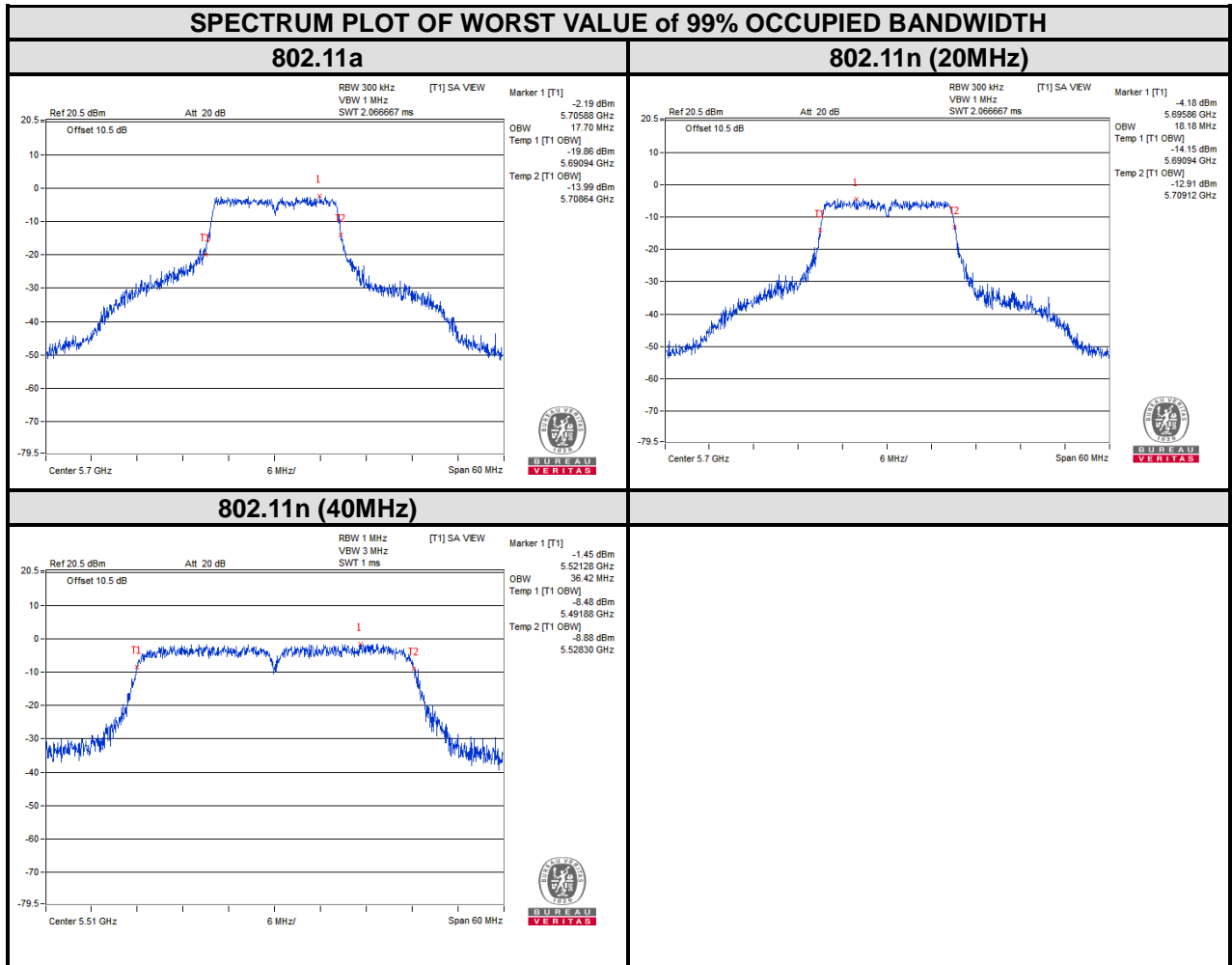

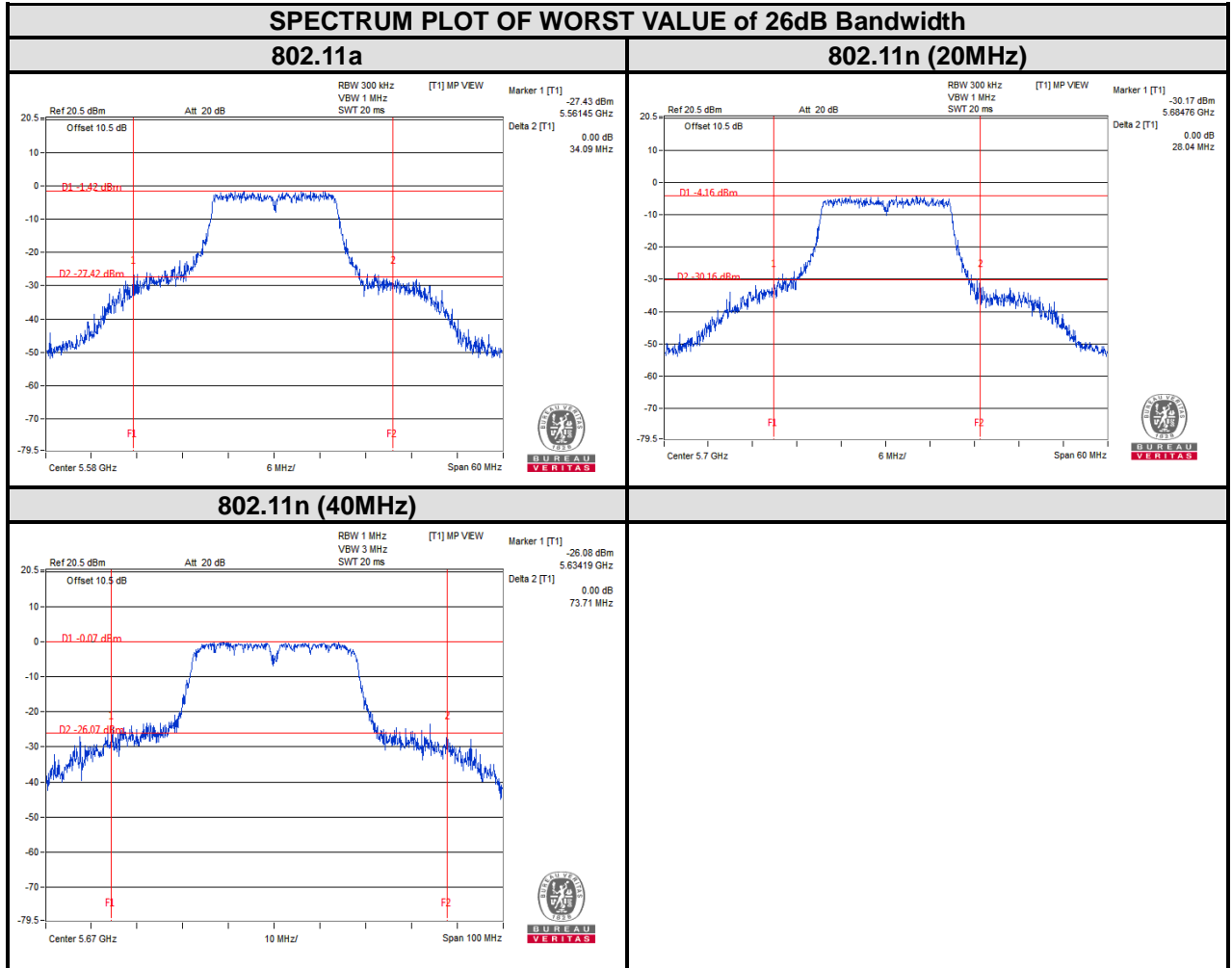



For U-NII-3:

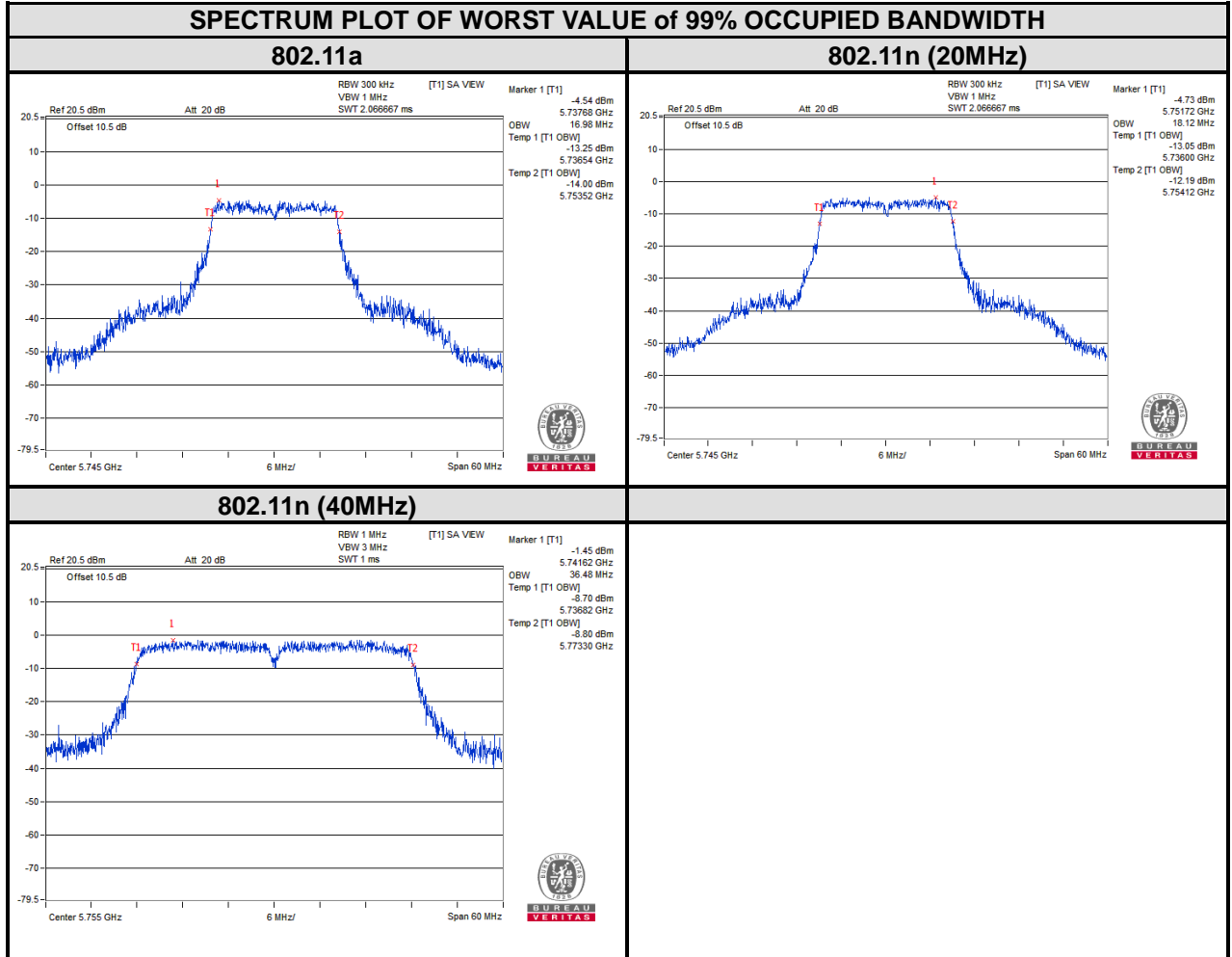

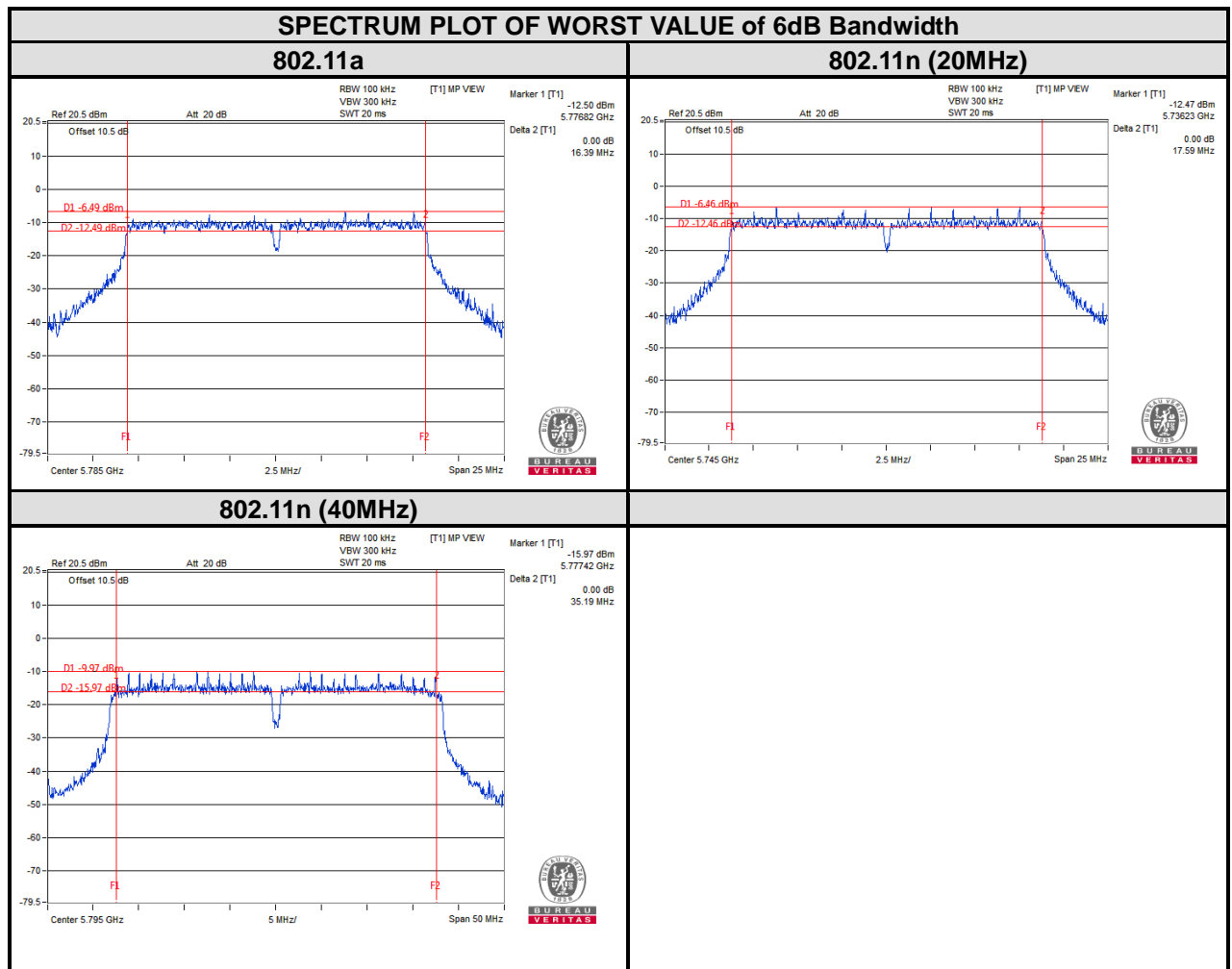

4.4 MAXIMUM POWER SPECTRAL DENSITY MEASUREMENT

4.4.1 LIMITS OF MAXIMUM POWER SPECTRAL DENSITY MEASUREMENT

Operation Band	EUT Category		LIMIT
U-NII-1		Outdoor Access Point	17dBm/ MHz
		Fixed point-to-point Access Point	
		Indoor Access Point	
	√	Client devices	11dBm/ MHz
U-NII-2A		√	11dBm/ MHz
U-NII-2C		√	11dBm/ MHz
U-NII-3		√	30dBm/ 500kHz

4.4.2 TEST SETUP

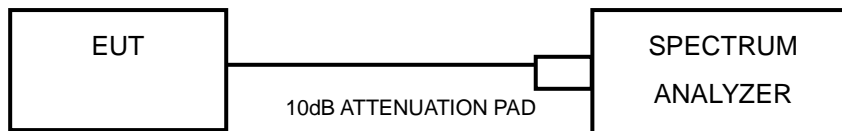

4.4.3 TEST INSTRUMENTS

Refer to section 4.3.3 to get information of above instrument.



4.4.4 TEST PROCEDURES

Using method SA-2

- 1) Set span to encompass the entire emission bandwidth (EBW) of the signal.
- 2) Set RBW = 1 MHz, Set VBW \geq 3 MHz, Detector = RMS
- 3) Set Channel power measure = 1MHz
- 4) Sweep time = auto, trigger set to "free run".
- 5) Trace average at least 100 traces in power averaging mode.
- 6) Add $10 \log(1/x)$, where x is the duty cycle, to the measured power in order to compute the average power during the actual transmission times (because the measurement represents an average over both the on and off times of the transmission).
- 7) Record the max value

4.4.5 DEVIATION FROM TEST STANDARD

No deviation.

4.4.6 EUT OPERATING CONDITIONS

Same as 4.1.6.

4.4.7 TEST RESULTS

For U-NII-1, U-NII-2A & U-NII-2C:

802.11a

CHANNEL	FREQUENCY (MHz)	PSD w/o Duty Factor (dBm/MHz)	Duty Factor	PSD with Duty Factor (dBm/MHz)	MAXIMUM LIMIT (dBm/MHz)	PASS/FAIL
36	5180	2.18	0.61	2.79	11	PASS
40	5200	0.79	0.61	1.40	11	PASS
48	5240	0.73	0.61	1.34	11	PASS
52	5260	0.00	0.61	0.61	11	PASS
60	5300	0.81	0.61	1.42	11	PASS
64	5320	-0.02	0.61	0.59	11	PASS
100	5500	-0.01	0.61	0.60	11	PASS
116	5580	1.36	0.61	1.97	11	PASS
140	5700	1.15	0.61	1.76	11	PASS

802.11n (20MHz)

CHANNEL	FREQUENCY (MHz)	PSD w/o Duty Factor (dBm/MHz)	Duty Factor	PSD with Duty Factor (dBm/MHz)	MAXIMUM LIMIT (dBm/MHz)	PASS/FAIL
36	5180	0.15	0.65	0.80	11	PASS
40	5200	0.02	0.65	0.67	11	PASS
48	5240	-0.13	0.65	0.52	11	PASS
52	5260	-1.42	0.65	-0.77	11	PASS
60	5300	-0.29	0.65	0.36	11	PASS
64	5320	-1.67	0.65	-1.02	11	PASS
100	5500	-1.28	0.65	-0.63	11	PASS
116	5580	-1.19	0.65	-0.54	11	PASS
140	5700	-0.85	0.65	-0.20	11	PASS

802.11n (40MHz)

CHANNEL	FREQUENCY (MHz)	PSD w/o Duty Factor (dBm/MHz)	Duty Factor	PSD with Duty Factor (dBm/MHz)	MAXIMUM LIMIT (dBm/MHz)	PASS/FAIL
38	5190	-2.58	1.24	-1.34	11	PASS
46	5230	-3.73	1.24	-2.49	11	PASS
54	5270	-2.56	1.24	-1.32	11	PASS
62	5310	-4.53	1.24	-3.29	11	PASS
102	5510	-4.69	1.24	-3.45	11	PASS
110	5550	-4.24	1.24	-3.00	11	PASS
134	5670	-3.10	1.24	-1.86	11	PASS

For U-NII-3:

802.11a

CHANNEL	FREQUENCY (MHz)	PSD w/o Duty Factor (dBm/MHz)	PSD w/o Duty Factor (dBm/500kHz)	Duty Factor	PSD with Duty Factor (dBm/500kHz)	LIMIT (dBm/500kHz)	PASS /FAIL
149	5745	3.36	0.35	0.61	0.96	30	PASS
157	5785	3.23	0.22	0.61	0.83	30	PASS
165	5825	2.84	-0.17	0.61	0.44	30	PASS

802.11n (20MHz)

CHANNEL	FREQUENCY (MHz)	PSD w/o Duty Factor (dBm/MHz)	PSD w/o Duty Factor (dBm/500kHz)	Duty Factor	PSD with Duty Factor (dBm/500kHz)	LIMIT (dBm/500kHz)	PASS /FAIL
149	5745	3.00	-0.01	0.65	0.64	30	PASS
157	5785	1.83	-1.18	0.65	-0.53	30	PASS
165	5825	1.21	-1.80	0.65	-1.15	30	PASS

802.11n (40MHz)

CHANNEL	FREQUENCY (MHz)	PSD w/o Duty Factor (dBm/MHz)	PSD w/o Duty Factor (dBm/500kHz)	Duty Factor	PSD with Duty Factor (dBm/500kHz)	LIMIT (dBm/500kHz)	PASS /FAIL
151	5755	0.27	-2.74	1.24	-1.50	30	PASS
159	5795	-1.65	-4.66	1.24	-3.42	30	PASS



Test Report No.: RF170829W003-3

For 5180~5240MHz

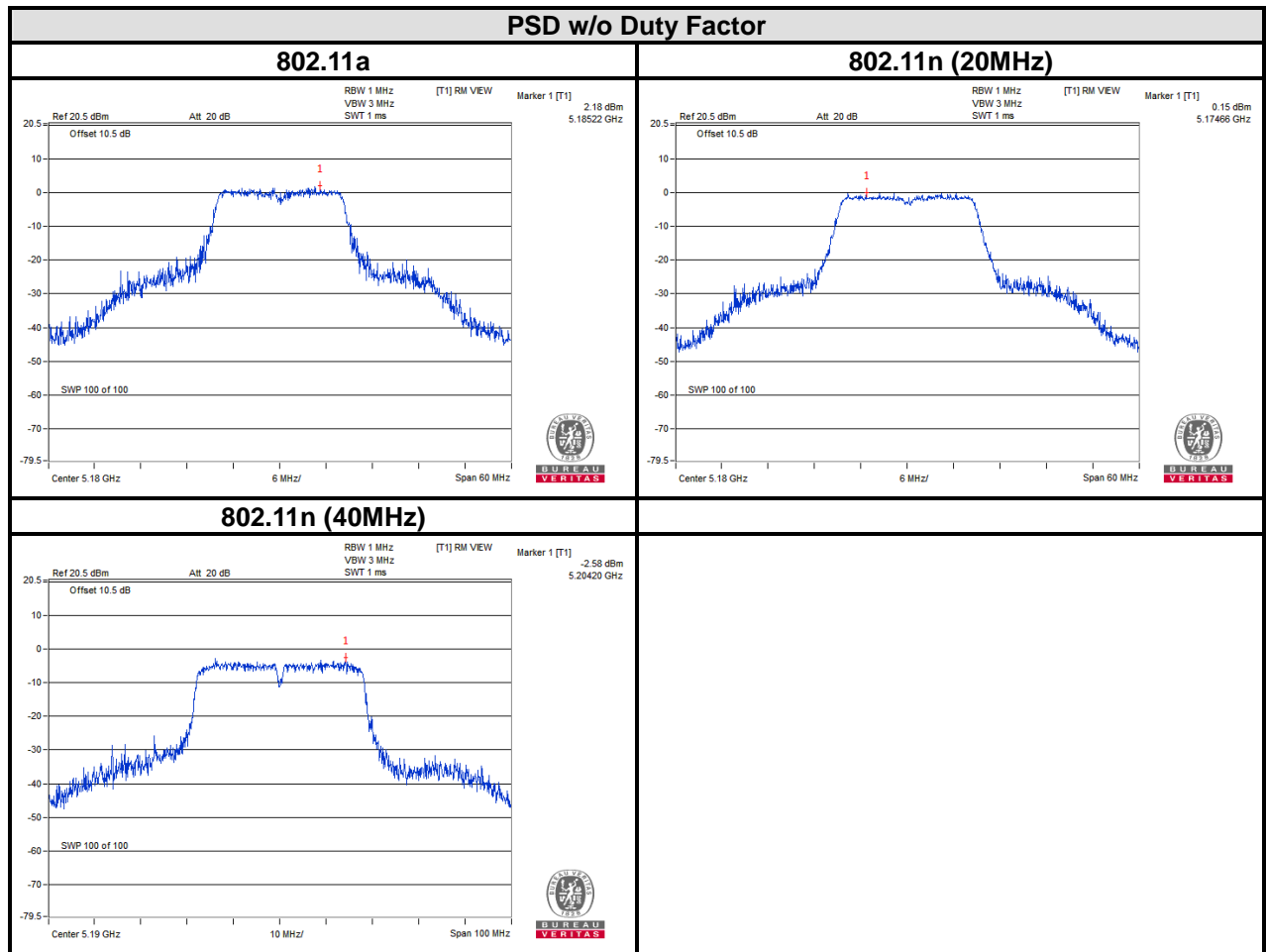



For 5260~5320MHz

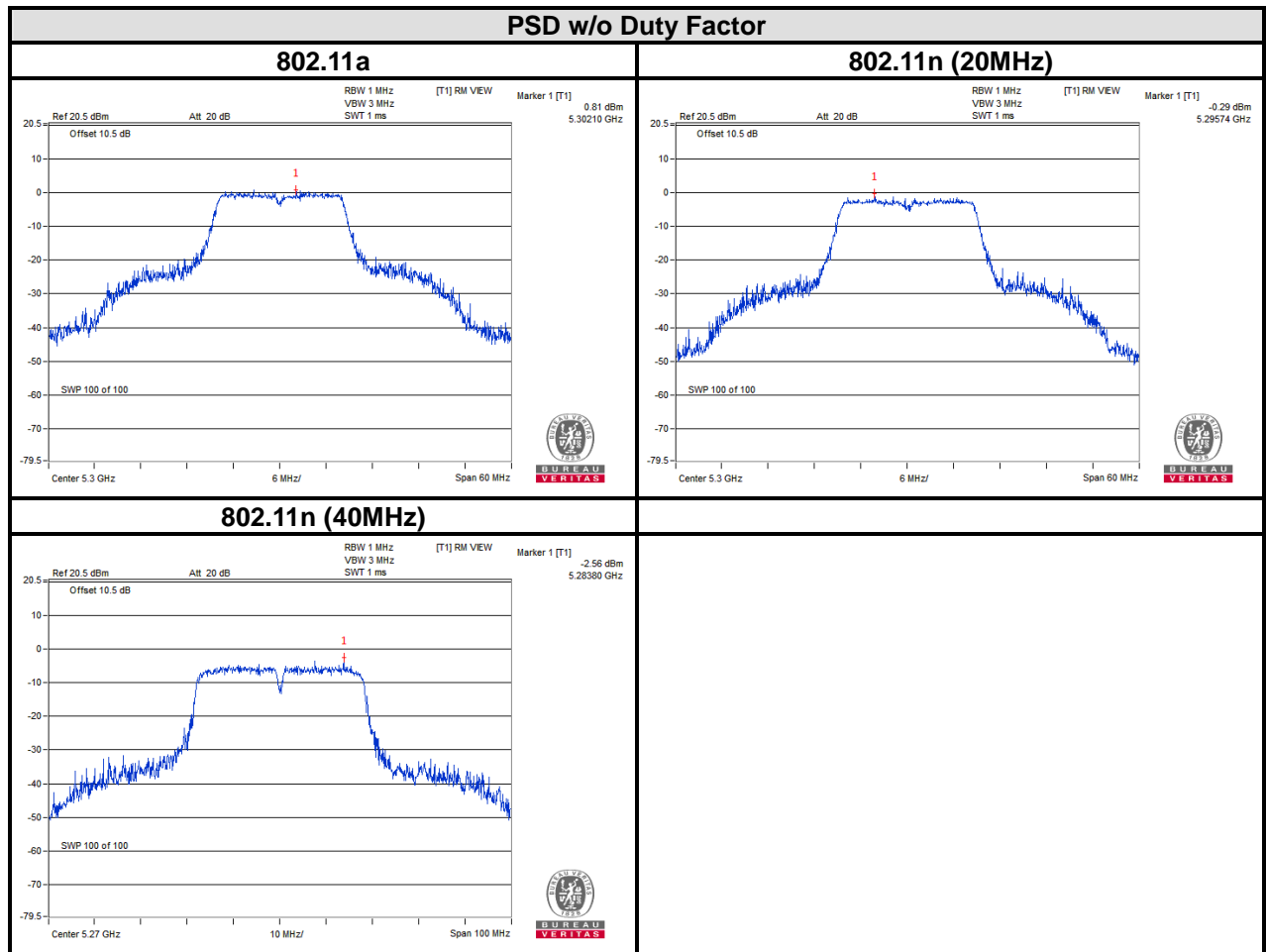



Test Report No.: RF170829W003-3

For 5500~5700MHz

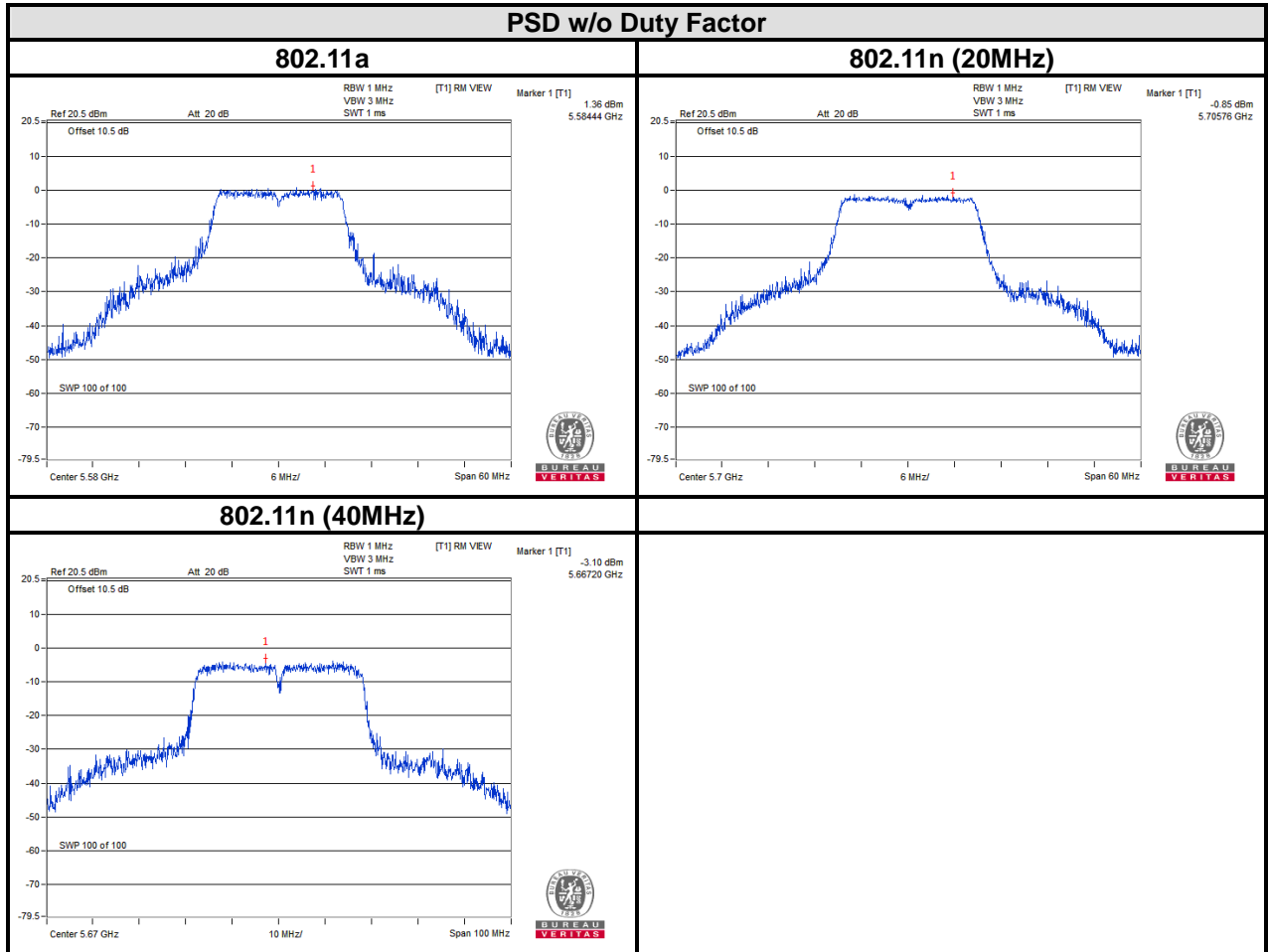



For 5745~5825MHz

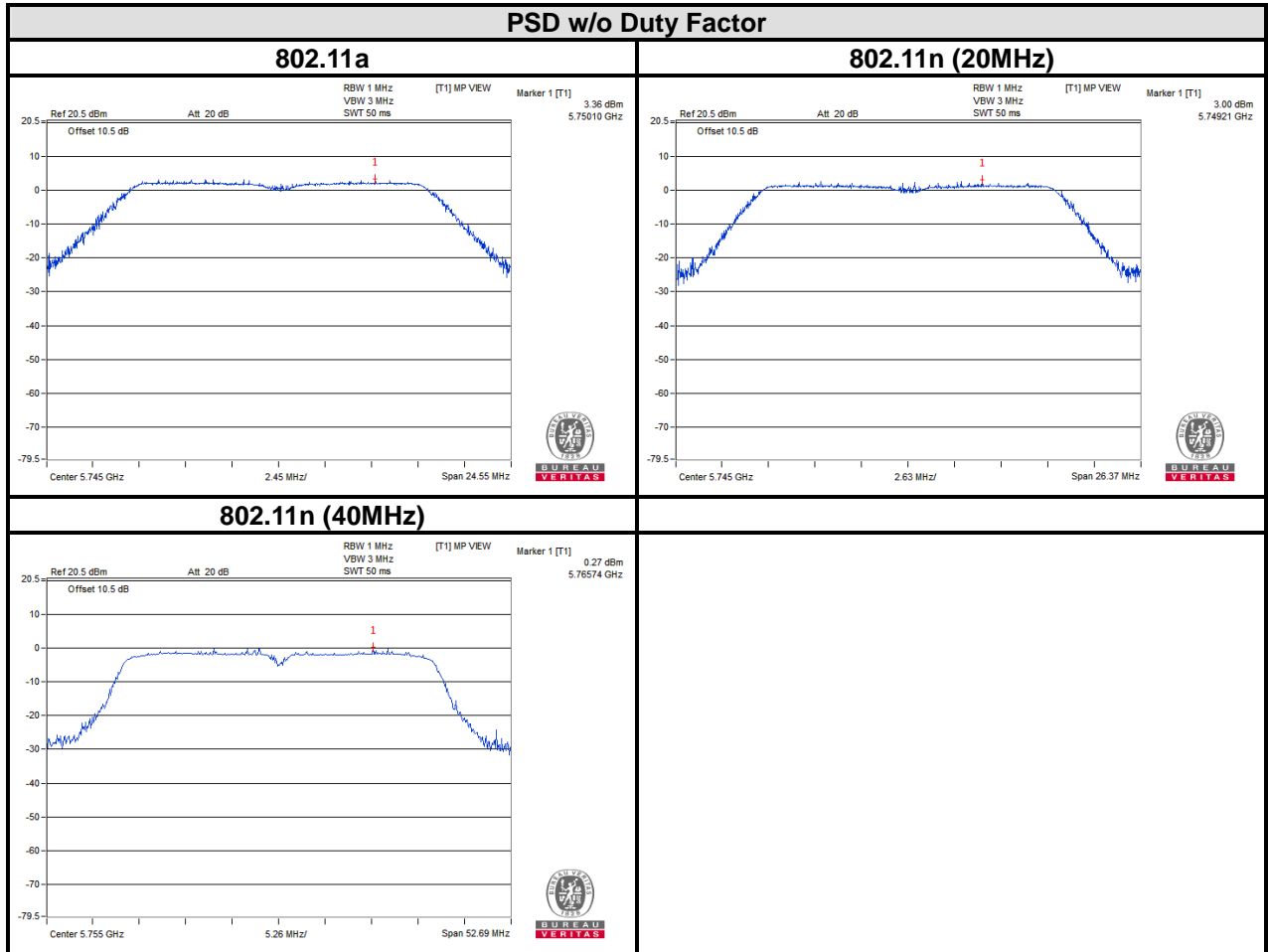

4.5 FREQUENCY STABILITY

4.5.1 LIMITS OF FREQUENCY STABILITY MEASUREMENT

The frequency of the carrier signal shall be maintained within band of operation

4.5.2 TEST SETUP

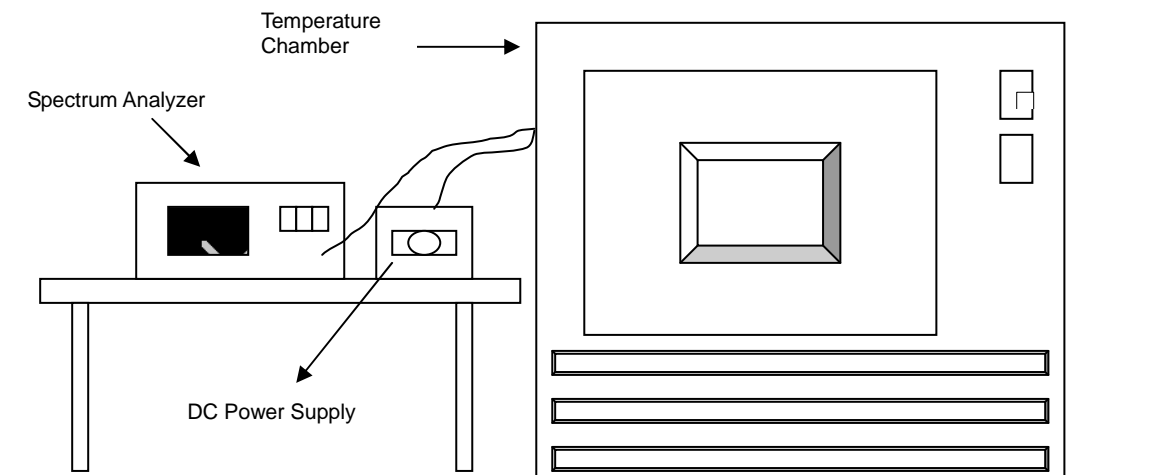

4.5.3 TEST INSTRUMENTS

Refer to section 4.3.3 to get information of above instrument.



4.5.4 TEST PROCEDURE

- a. The EUT was placed inside the environmental test chamber and powered by nominal DC voltage.
- b. Turn the EUT on and couple its output to a spectrum analyzer.
- c. Turn the EUT off and set the chamber to the highest temperature specified.
- d. Allow sufficient time (approximately 30 min) for the temperature of the chamber to stabilize, turn the EUT on and measure the operating frequency after 2, 5, and 10 minutes.
- e. Repeat step 2 and 3 with the temperature chamber set to the lowest temperature.
- f. The test chamber was allowed to stabilize at +20 degree C for a minimum of 30 minutes. The supply voltage was then adjusted on the EUT from 85% to 115% and the frequency record.

4.5.5 DEVIATION FROM TEST STANDARD

No deviation.

4.5.6 EUT OPERATING CONDITION

Set the EUT transmit at un-modulation mode to test frequency stability.



4.5.7 TEST RESULTS

FREQUENCY STABILITY VERSUS TEMP.										
OPERATING FREQUENCY: 5180MHz										
TEMP. (°C)	Power Supply (Vdc)	0 MINUTE		2 MINUTES		5 MINUTES		10 MINUTE		RESULT
		Measured Frequency (MHz)	Frequency Drift (ppm)	Measured Frequency (MHz)	Frequency Drift (ppm)	Measured Frequency (MHz)	Frequency Drift (ppm)	Measured Frequency (MHz)	Frequency Drift (ppm)	
50	120	5179.9764	-4.556	5179.9736	-5.097	5179.9773	-4.382	5179.9749	-4.846	PASS
40	120	5180.0008	0.154	5180.0009	0.174	5180.0034	0.656	5179.9997	-0.058	PASS
30	120	5179.9857	-2.761	5179.9864	-2.625	5179.9844	-3.012	5179.9822	-3.436	PASS
20	120	5179.985	-2.896	5179.9869	-2.529	5179.9836	-3.166	5179.9868	-2.548	PASS
10	120	5179.9831	-3.263	5179.9834	-3.205	5179.9827	-3.340	5179.9798	-3.900	PASS
0	120	5179.9795	-3.958	5179.988	-2.317	5179.9847	-2.954	5179.9856	-2.780	PASS
-10	120	5180.0049	0.946	5179.9973	-0.521	5180.0031	0.598	5180.0068	1.313	PASS
-20	120	5179.9762	-4.595	5179.9722	-5.367	5179.9731	-5.193	5179.9732	-5.174	PASS
-30	120	5180.0174	3.359	5180.021	4.054	5180.0232	4.479	5180.0235	4.537	PASS

FREQUENCY STABILITY VERSUS VOLTAGE										
OPERATING FREQUENCY: 5180MHz										
TEMP. (°C)	Power Supply (Vdc)	0 MINUTE		2 MINUTE		5 MINUTE		10 MINUTE		RESULT
		Measured Frequency (MHz)	Frequency Drift (ppm)	Measured Frequency (MHz)	Frequency Drift (ppm)	Measured Frequency (MHz)	Frequency Drift (ppm)	Measured Frequency (MHz)	Frequency Drift (ppm)	
20	138	5179.9854	-2.819	5179.9866	-2.587	5179.9836	-3.166	5179.9885	-2.220	PASS
	120	5179.985	-2.896	5179.9869	-2.529	5179.9836	-3.166	5179.9868	-2.548	PASS
	102	5179.9857	-2.761	5179.9853	-2.838	5179.985	-2.896	5179.9868	-2.548	PASS

FREQUENCY STABILITY VERSUS TEMP.										
OPERATING FREQUENCY: 5825MHz										
TEMP. (°C)	Power Supply (Vdc)	0 MINUTE		2 MINUTES		5 MINUTES		10 MINUTE		RESULT
		Measured Frequency (MHz)	Frequency Drift (ppm)	Measured Frequency (MHz)	Frequency Drift (ppm)	Measured Frequency (MHz)	Frequency Drift (ppm)	Measured Frequency (MHz)	Frequency Drift (ppm)	
50	120	5824.9783	-3.725	5824.9782	-3.742	5824.9789	-3.622	5824.9678	-5.528	PASS
40	120	5824.9816	-3.159	5824.9862	-2.369	5824.9816	-3.159	5824.9794	-3.536	PASS
30	120	5825.0102	1.751	5825.0052	0.893	5825.0115	1.974	5825.0133	2.283	PASS
20	120	5824.982	-3.090	5824.9757	-4.172	5824.9794	-3.536	5824.9768	-3.983	PASS
10	120	5824.9784	-3.708	5824.9733	-4.584	5824.9745	-4.378	5824.9752	-4.258	PASS
0	120	5824.9884	-1.991	5824.9796	-3.502	5824.9831	-2.901	5824.9806	-3.330	PASS
-10	120	5825.0325	5.579	5825.0285	4.893	5825.0229	3.931	5825.0249	4.275	PASS
-20	120	5825.0254	4.361	5825.0312	5.356	5825.0299	5.133	5825.0333	5.717	PASS
-30	120	5824.9758	-4.155	5824.9783	-3.725	5824.9762	-4.086	5824.976	-4.120	PASS

FREQUENCY STABILITY VERSUS VOLTAGE										
OPERATING FREQUENCY: 5180MHz										
TEMP. (°C)	Power Supply (Vdc)	0 MINUTE		2 MINUTE		5 MINUTE		10 MINUTE		RESULT
		Measured Frequency (MHz)	Frequency Drift (ppm)	Measured Frequency (MHz)	Frequency Drift (ppm)	Measured Frequency (MHz)	Frequency Drift (ppm)	Measured Frequency (MHz)	Frequency Drift (ppm)	
20	138	5824.9834	-2.850	5824.9755	-4.206	5824.9809	-3.279	5824.9767	-4.000	PASS
	120	5824.982	-3.090	5824.9757	-4.172	5824.9794	-3.536	5824.9768	-3.983	PASS
	102	5824.9831	-2.901	5824.9767	-4.000	5824.9795	-3.519	5824.9776	-3.845	PASS



Test Report No.: RF170829W003-3

5 PHOTOGRAPHS OF THE TEST CONFIGURATION

Please refer to the attached file (Test Setup Photo).



Test Report No.: RF170829W003-3

6 APPENDIX A – MODIFICATIONS RECORDERS FOR ENGINEERING CHANGES TO THE EUT BY THE LAB

No modifications were made to the EUT by the lab during the test.

---END---