

# Aquarium Luminaire

# Model No.: 14539

## IMPORTANT SAFETY INSTRUCTIONS

**WARNING** – To guard against injury, basic safety precautions should be observed, including the following:

## READ AND FOLLOW ALL SAFETY INSTRUCTIONS

and all the important notices on the appliance before using. Failure to do so may result in loss of fish life and/or damage to this appliance.

**DANGER** – To avoid possible electric shock, special care should be taken since water is employed in the use of aquarium equipment. For each of the following situations, do not attempt repairs yourself; return the appliance to an authorized service facility for service or discard the appliance.

A. If the appliance shows any sign of abnormal water leakage, immediately unplug it from the power source.

B. Carefully examine the appliance after installation. It should not be plugged in if there is water on parts not intended to be wet. **If the appliance or any part of it falls into the water DO NOT reach for it. First unplug the unit before retrieving.**

C. Do not operate any appliance if it has a damaged cord or plug, or if it is malfunctioning or it is dropped or damaged in any manner. The power cord of this appliance cannot be replaced; if the cord is damaged, the appliance should be discarded. Never cut the cord.

D. To avoid the possibility of the appliance plug or receptacle getting wet, position the appliance to one side of a wall mounted receptacle to prevent water from dripping onto the receptacle or plug. A "drip loop" (see illustration) should be arranged by the user for the cord connecting appliance to a receptacle. "The drip loop" is that part of the cord below the level of the receptacle or the connector if an extension cord is used, to prevent water travelling along the cord and coming in contact with the receptacle. If the plug or receptacle does get wet, **DO NOT** unplug the cord. Disconnect the fuse or circuit breaker that supplies power to the appliance. Then unplug and examine for presence of water in receptacle.

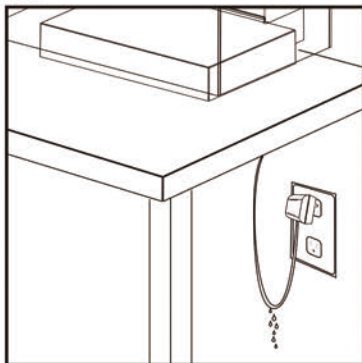

This appliance is not intended for use by persons (including children) with significantly impaired physical or mental capabilities, unless they have been given supervision or instruction concerning the use of the appliance by a person responsible for their safety. Children should always be supervised to ensure that they do not play with the appliance.

To avoid injury, do not touch moving parts or hot parts.

**CAUTION** - Always unplug or disconnect all appliances in the aquarium from electricity supply before placing hands in water, before putting on or taking off parts and while the equipment is being installed, maintained or handled. Never yank cord to pull plug from outlet. Grasp the plug and pull to disconnect. Always unplug an appliance from an outlet when not in use.

Do not install or store the appliance where it will be exposed to weather or temperatures below freezing. **FOR INDOOR HOUSEHOLD USE ONLY. DO NOT IMMERS**

Make sure the appliance is mounted correctly and securely positioned on the aquarium before operating the appliance.

If an extension cord is necessary, a cord with proper rating should be used. A cord rated for less amperes or watts than the appliance rating may overheat. Care should be taken to arrange the cord so that it will not be tripped over or pulled. The connection should be carried out by a qualified electrical installer.

The socket-outlet shall be installed near the equipment and shall be easily accessible.

## SAVE THESE INSTRUCTIONS

For the complete use and understanding of this product it is recommended that this manual is thoroughly read and understood. Failure to do so may result in damage to this product.

For full instruction manual and video on set up of Bluetooth® application, visit: [fluvalaquatics.com/plantnano](http://fluvalaquatics.com/plantnano)

Download the Free SmartAPP now:



## INSTALLATION

Not for use on aquariums with top frames.

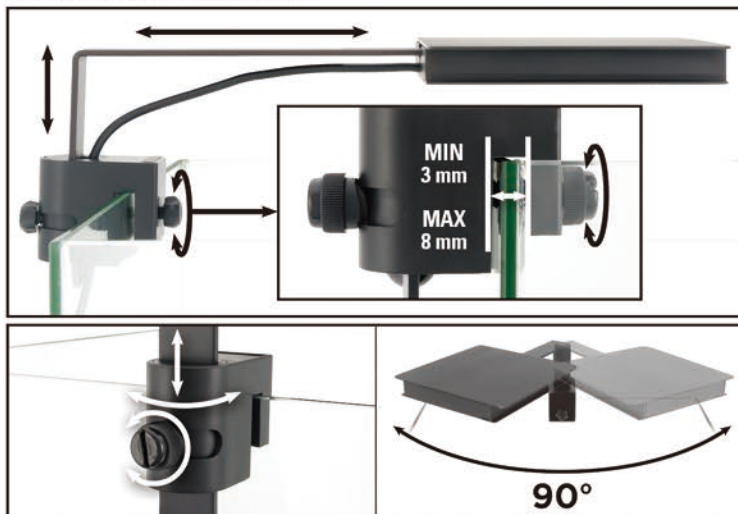

## BASIC TROUBLE-SHOOTING:

If the fixture does not work, ensure that all plugs and wires are firmly connected, ie: connection from fixture to transformer, and connection from transformer to electrical outlet.

## MAINTENANCE:

Before any kind of maintenance, always disconnect electrical supply of the light fixture. For maximum LED performance, it is recommended that the fixture and the LED lens be cleaned on a weekly basis. Unplug transformer prior to cleaning the light fixture and remove from aquarium. Use both hands when manipulating this appliance. Wipe exposed surfaces carefully with a damp cloth to remove any dust or mineral deposits that may collect over time. Do not use detergents or harsh cleaners as it can damage the light fixture. Use Fluval LED Lens Cleaning Non-Aerosol Spray (A3969) to clean the LED portion of the light fixture. Make sure all surfaces are dry before re-connecting the transformer to the power source.

## WARRANTY

### 3 YEAR LIMITED WARRANTY

Your Fluval Plant Nano LED is guaranteed for defective parts and workmanship for a period of 3 years from the date of purchase. This guarantee is valid with proof of purchase only. The guarantee is limited to repair or replacement only and does not cover consequential loss, loss or damage to livestock and personal property or damage to animate or inanimate objects, irrespective of the cause thereof. This guarantee is valid only under normal operating conditions for which the unit is intended. It excludes any damage caused by unreasonable use, negligence, improper installation, tampering, abuse or commercial use. The warranty does not cover wear and tear or parts which have not been adequately or correctly maintained. Failure of less than 5% of the total number of LEDs shall not be considered a defect under the terms of this warranty. **THIS DOES NOT AFFECT YOUR STATUTORY RIGHTS.**

### FOR AUTHORIZED WARRANTY REPAIR SERVICE:

For Authorized Warranty Service please return (well packaged and by registered post) to the address below enclosing dated receipt and reason for return. If you have any queries or comments about the operation of this product, please let us try to help you before you return the product to your retailer. Most queries can be handled promptly with a phone call. When you call (or write), please have all relevant information such as model number, age of product, details of aquarium set-up, as well as the nature of the problem.

**CANADA: Consumer Repair,** Rolf C. Hagen Inc., 20500 Trans Canada Hwy, Baie-D'Urfé, QC H9X 0A2

**U.S.A.: Rolf C. Hagen (U.S.A.) Corp.,** 305 Forbes Blvd, Mansfield, MA 02048

**UK: Rolf C. Hagen (UK) Ltd,** Customer Service Department California Drive, Whitwood Ind Est., Castleford West Yorkshire WF10 5QH [www.hagen-uk.custhelp.com](http://www.hagen-uk.custhelp.com)

### CALL US ON OUR TOLL-FREE NUMBER:

**CANADA ONLY:** 1-800-554-2436 between 9:00 a.m. and 4:30 p.m. Eastern Standard Time.

Ask for Customer Service.

**U.S. ONLY:** 1-800-724-2436 between 9:00 a.m. and 4:00 p.m. Eastern Standard Time.

Ask for Customer Service.

**U.K. ONLY:** Helpline Number 01977 521015. Between 9:00 AM and 5:00 PM, Monday to Thursday and 9:00 AM and 4:00 PM on Friday (excluding Bank Holidays).



**RECYCLING:** This symbol bears the selective sorting symbol for waste electrical and electronic equipment (WEEE). This means that this product must be handled pursuant to European Directive 2012/19/EU in order to be recycled or dismantled to minimize its impact on the environment. Check with your local Environmental Agency for possible disposal instructions or take to an official council registered refuse collection point. Electronic products not included in the selective sorting process are potentially dangerous for the environment and human health due to the presence of hazardous substances.

## FCC Warning:

This equipment has been tested and found to comply with the limits for a Class B digital device, pursuant to part 15 of the FCC Rules. These limits are designed to provide reasonable protection against harmful interference in a residential installation. This equipment generates, uses and can radiate radio frequency energy and, if not installed and used in accordance with the instructions, may cause harmful interference to radio communications. However, there is no guarantee that interference will not occur in a particular installation. If this equipment does cause harmful interference to radio or television reception, which can be determined by turning the equipment off and on, the user is encouraged to try to correct the interference by one or more of the following measures:

- o Reorient or relocate the receiving antenna.
- o Increase the separation between the equipment and receiver.
- o Connect the equipment into an outlet on a circuit different from that to which the receiver is connected.
- o Consult the dealer or an experienced radio/TV technician for help.

Caution: Any changes or modifications to this device not explicitly approved by manufacturer could void your authority to operate this equipment.

This device complies with part 15 of the FCC Rules. Operation is subject to the following two conditions: (1) This device may not cause harmful interference, and (2) this device must accept any interference received, including interference that may cause undesired operation.

The device has been evaluated to meet general RF exposure requirement. The device can be used in portable exposure condition without restriction.