

Test Setup

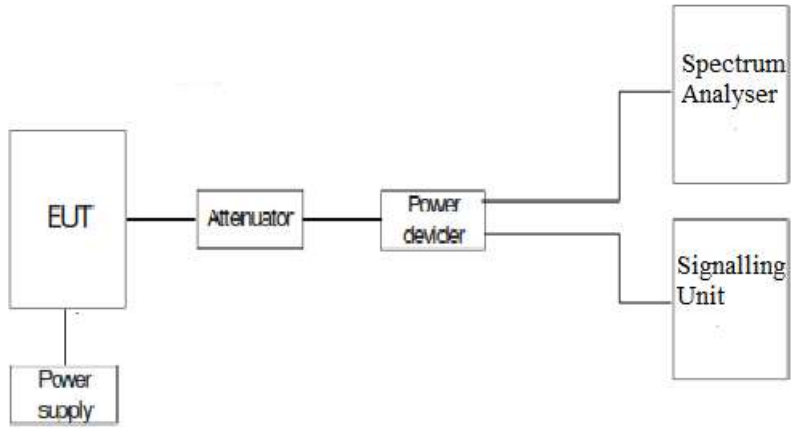

Results

Test performed on the worst-case modulation, RB Size and RB Offset for each LTE band.

LTE Cat-M1 Band 26. Sub-band 814-824 MHz: BW = 10 MHz. 16QAM. RB Size=3. RB Offset=1.

Frequency range 9 KHz - 10 GHz:

- Middle Channel: No spurious frequencies detected at less than 20 dB below the limit.

LTE Cat-M1 Band 26. Cross-rule Channel 824 MHz: BW = 15 MHz. 16QAM. RB Size=1. RB Offset=0.

Frequency range 9 KHz - 10 GHz:

- Single Channel: No spurious frequencies detected at less than 20 dB below the limit.

Verdict

PASS

LTE Cat-M1 Band 26. Sub-band 814-824 MHz:

BW = 10 MHz. 16QAM. RB Size=3. RB Offset=1.

Middle Channel:

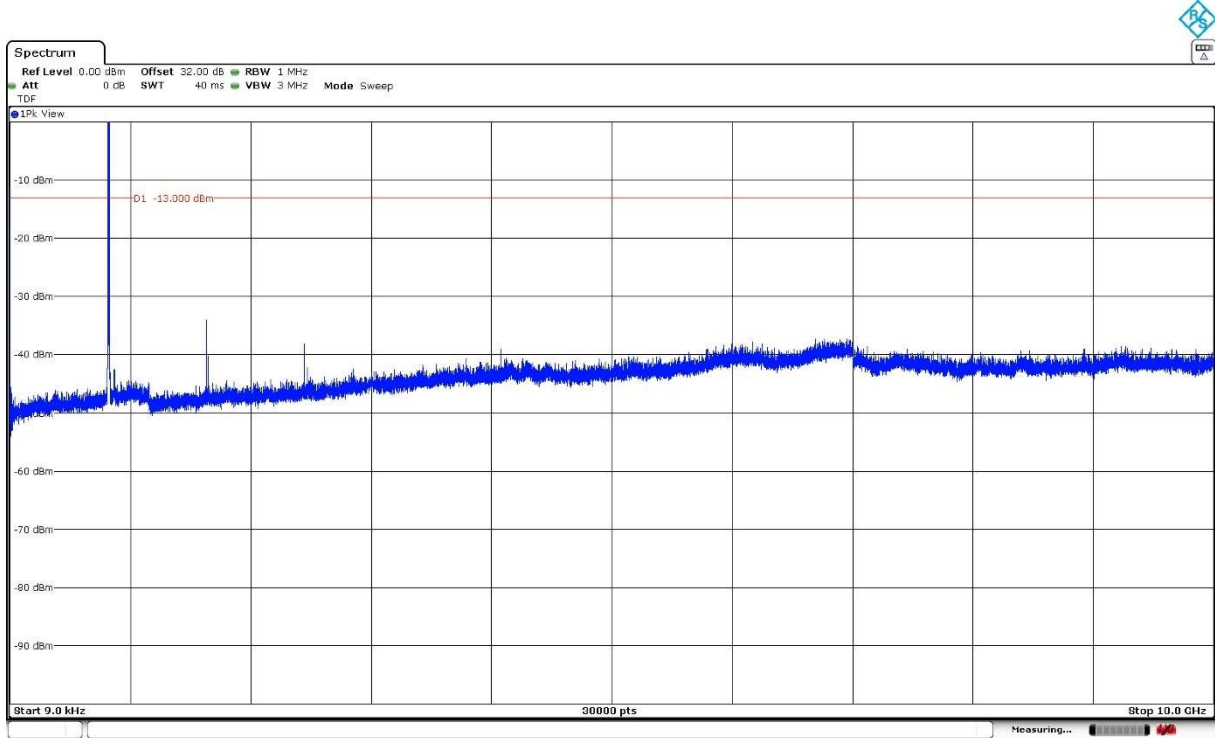

The peak above the limit is the carrier frequency.

LTE Cat-M1 Band 26. Cross-rule Channel 824 MHz:

BW = 15 MHz. 16QAM. RB Size=1. RB Offset=0.

Single Channel:

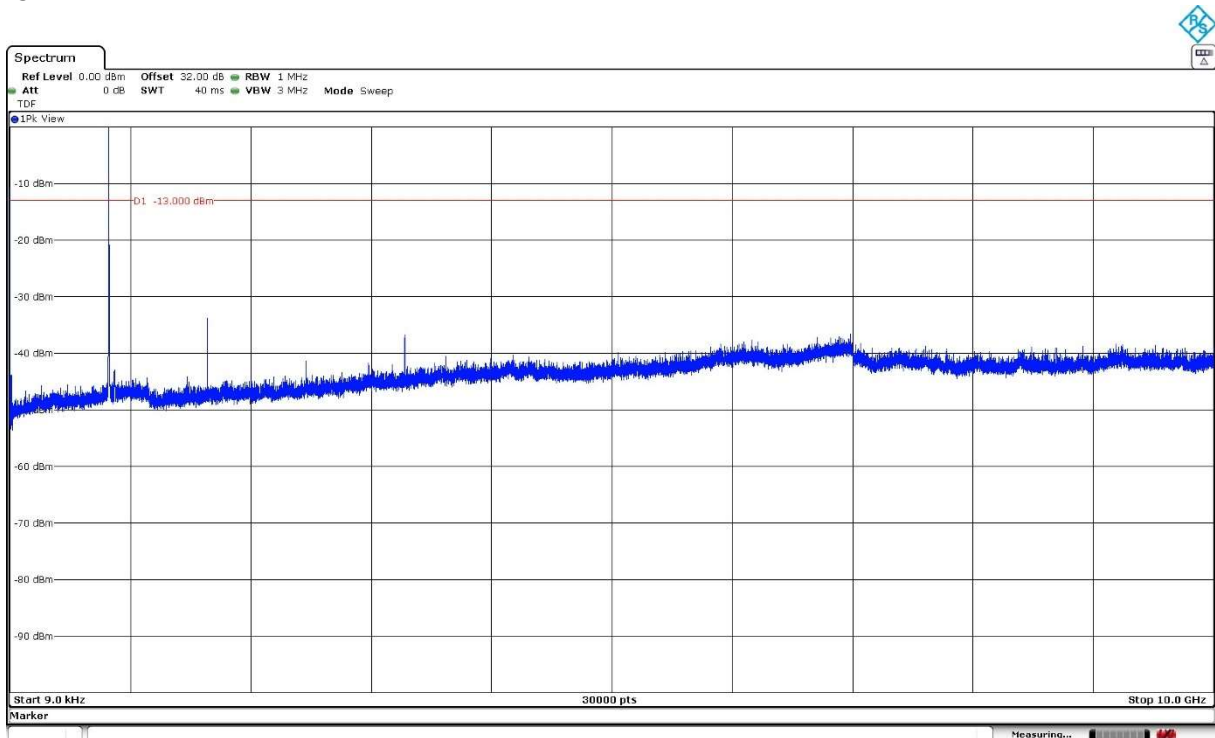

The peak above the limit is the carrier frequency.

Spurious Emissions at Antenna Terminals at Block Edges

Limits

* FCC §2.1051:

The power of any emission outside of the authorized operating frequency ranges must be attenuated below the transmitting power (P) by a factor of at least $43 + 10 \log(P)$ dB.

Compliance with these rules is based on the use of measurement instrumentation employing a reference bandwidth as follows:

In the spectrum below 1 GHz, instrumentation should employ a reference bandwidth of 100 kHz or greater. In the 1 MHz bands immediately outside and adjacent to the frequency block, a resolution bandwidth of at least one percent of the emission bandwidth of the fundamental emission of the transmitter may be employed.

* FCC §90.691:

(a) Out-of-band emission requirement shall apply only to the “outer” channels included in an EA license and to spectrum adjacent to interior channels used by incumbent licensees. The emission limits are as follows:

(1) For any frequency removed from the EA licensee's frequency block by up to and including 37.5 kHz, the power of any emission shall be attenuated below the transmitter power (P) in watts by at least $116 \log_{10}(f/6.1)$ decibels or $50 + 10 \log_{10}(P)$ decibels or 80 decibels, whichever is the lesser attenuation, where f is the frequency removed from the center of the outer channel in the block in kilohertz and where f is greater than 12.5 kHz.

(2) For any frequency removed from the EA licensee's frequency block greater than 37.5 kHz, the power of any emission shall be attenuated below the transmitter power (P) in watts by at least $43 + 10 \log_{10}(P)$ decibels or 80 decibels, whichever is the lesser attenuation, where f is the frequency removed from the center of the outer channel in the block in kilohertz and where f is greater than 37.5 kHz.

Method

The EUT RF output connector was connected to a spectrum analyzer and to the Universal Radio Communication tester R&S CMW500 (selecting maximum transmission power of the EUT and different modes of modulation) using a 50-Ohm attenuator and a power splitter.

The reading of the spectrum analyser is corrected with the path loss of the connection between the output terminal of the EUT and the input of the spectrum analyzer.

The configuration of modulation which is the worst case for conducted power was used.

As stated in FCC §2.1051, in the 1 MHz bands immediately outside and adjacent to the frequency block or band a resolution bandwidth of at least one percent of the emission bandwidth of the fundamental emission of the transmitter may be employed.

Measurement Limit:

At P_o transmitting power, the specified minimum attenuation $43 + 10 \log_{10} p$ (watts) becomes:

$$P_o \text{ (dBm)} - [43 + 10 \log (P_o \text{ in mwatts}) - 30] = -13 \text{ dBm}$$

Test Setup

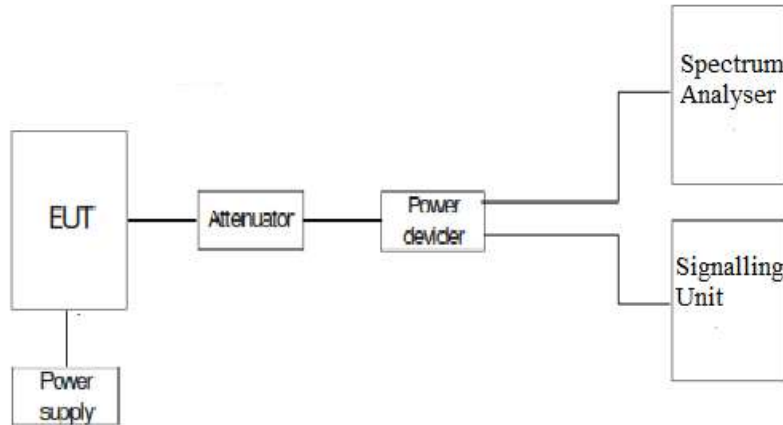

Results

Sub-band 814-824 MHz:

Preliminary measurements determined the BW=1.4 MHz, 16QAM as the worst case. Results attached are for this worst-case configuration.

LTE Cat-M1 Band 26. 16QAM.	RB=1. Offset=0. BW=1.4 MHz	RB=1. Offset=0. BW=3 MHz	RB=1. Offset=0. BW=5 MHz	RB=1. Offset=0. BW=10 MHz
Maximum measured level at <u>Low Block Edge</u> at antenna port (dBm)	-14.25	-15.45	-30.61	-23.09

LTE Cat-M1 Band 26. 16QAM.	RB=5. Offset=0. BW=1.4 MHz	RB=5. Offset=0. BW=3 MHz	RB=5. Offset=0. BW=5 MHz	RB=5. Offset=0. BW=10 MHz
Maximum measured level at <u>Low Block Edge</u> at antenna port (dBm)	-14.81	-21.19	-15.73	-25.54

LTE Cat-M1 Band 26. 16QAM.	RB=1. Offset=Max. BW=1.4 MHz	RB=1. Offset=Max. BW=3 MHz	RB=1. Offset=Max. BW=5 MHz	RB=1. Offset=Max. BW=10 MHz
Maximum measured level at <u>High Block Edge</u> at antenna port (dBm)	-14.37	-20.9	-17.78	-25.77

LTE Cat-M1 Band 26. 16QAM.	RB=5. Offset=1. BW=1.4 MHz	RB=5. Offset=1. BW=3 MHz	RB=5. Offset=1. BW=5 MHz	RB=5. Offset=1. BW=10 MHz
Maximum measured level at <u>High Block Edge</u> at antenna port (dBm)	-16.05	-21.71	-22.09	-29.48

Measurement uncertainty (dB): ± 2.76

Verdict

Pass

Sub-band 814-824 MHz. EA MASK: BW=1.4 MHz. RB Size=1. RB Offset=0. Narrow Band=0. Low Block Edge:

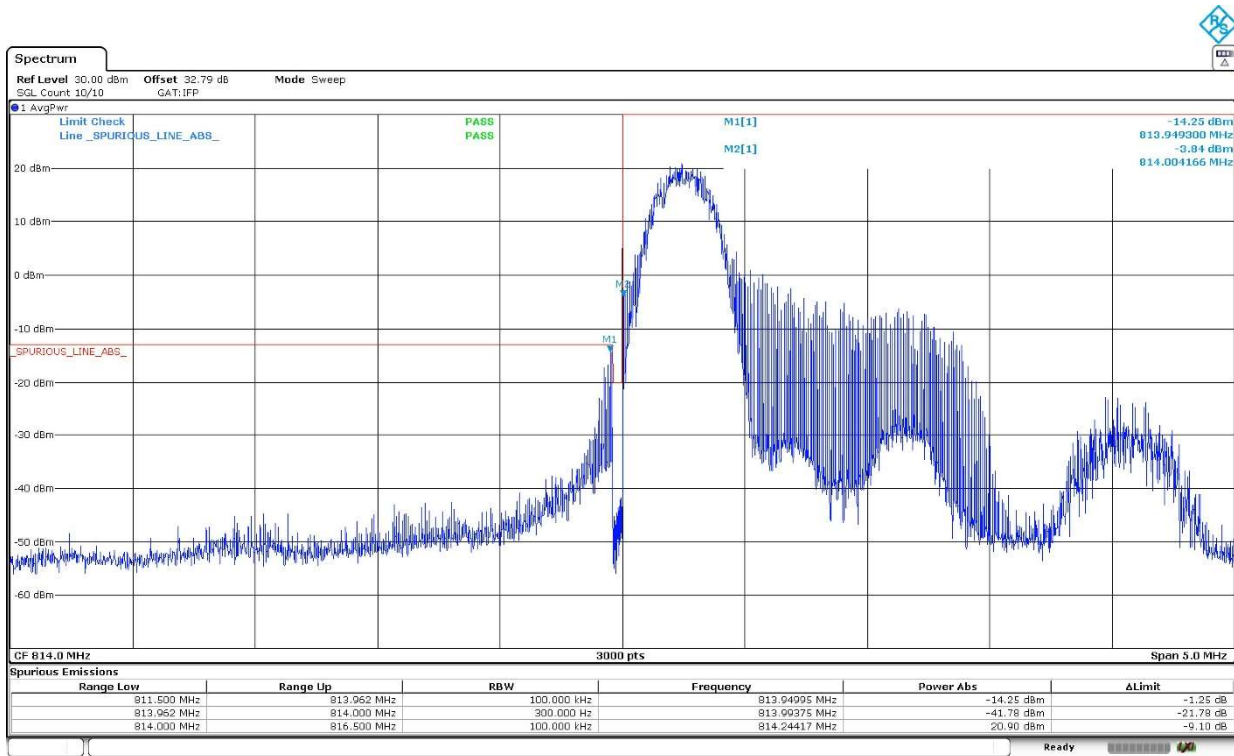

Sub-band 814-824 MHz. EA MASK: BW=1.4 MHz. RB Size=5. RB Offset=0. Narrow Band=0. Low Block Edge:

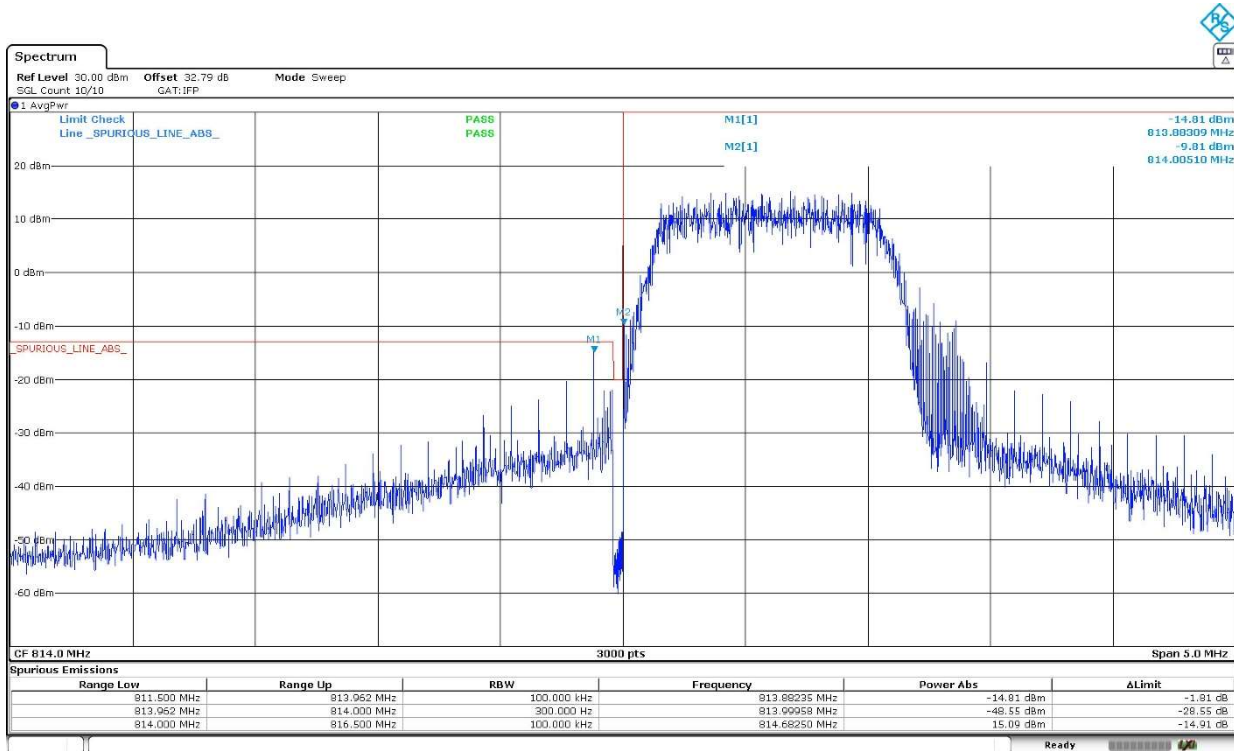

Sub-band 814-824 MHz. EA MASK: BW=1.4 MHz. RB Size=1. RB Offset=Max. Narrow Band=0. High Block Edge:

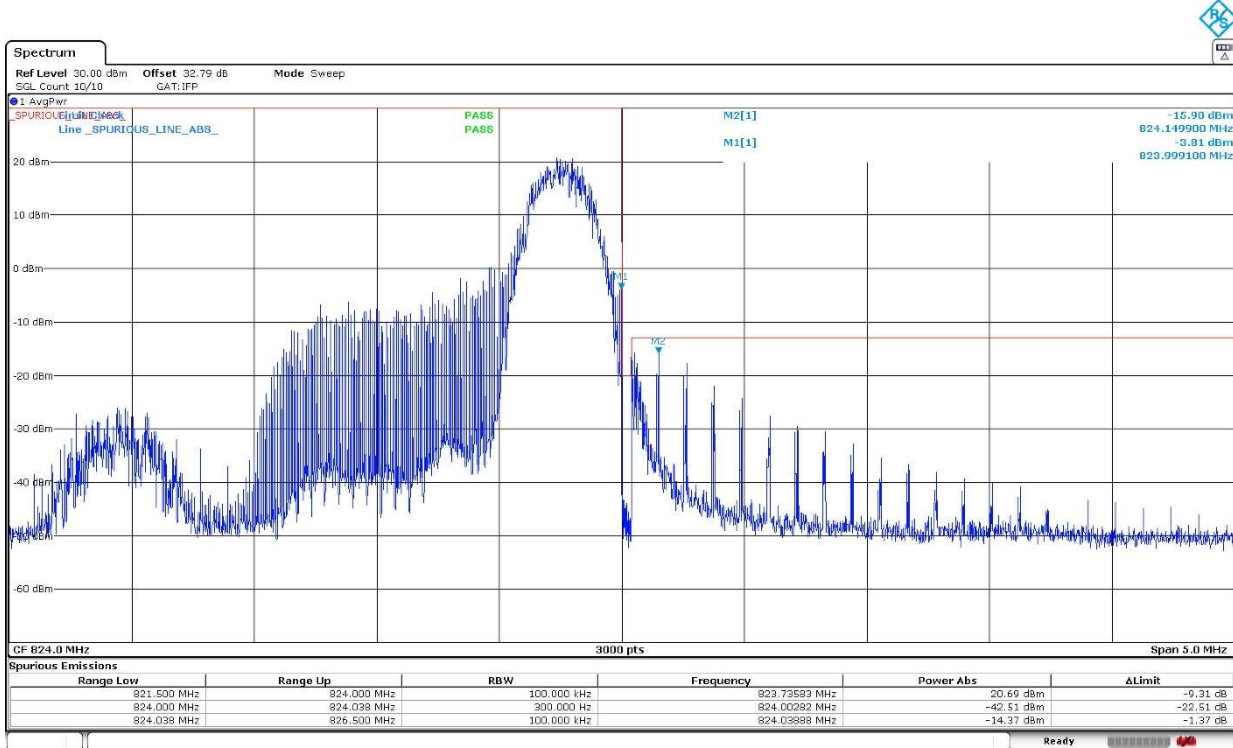

Sub-band 814-824 MHz. EA MASK: BW=1.4 MHz. RB Size=5. RB Offset=1. Narrow Band=0. High Block Edge:

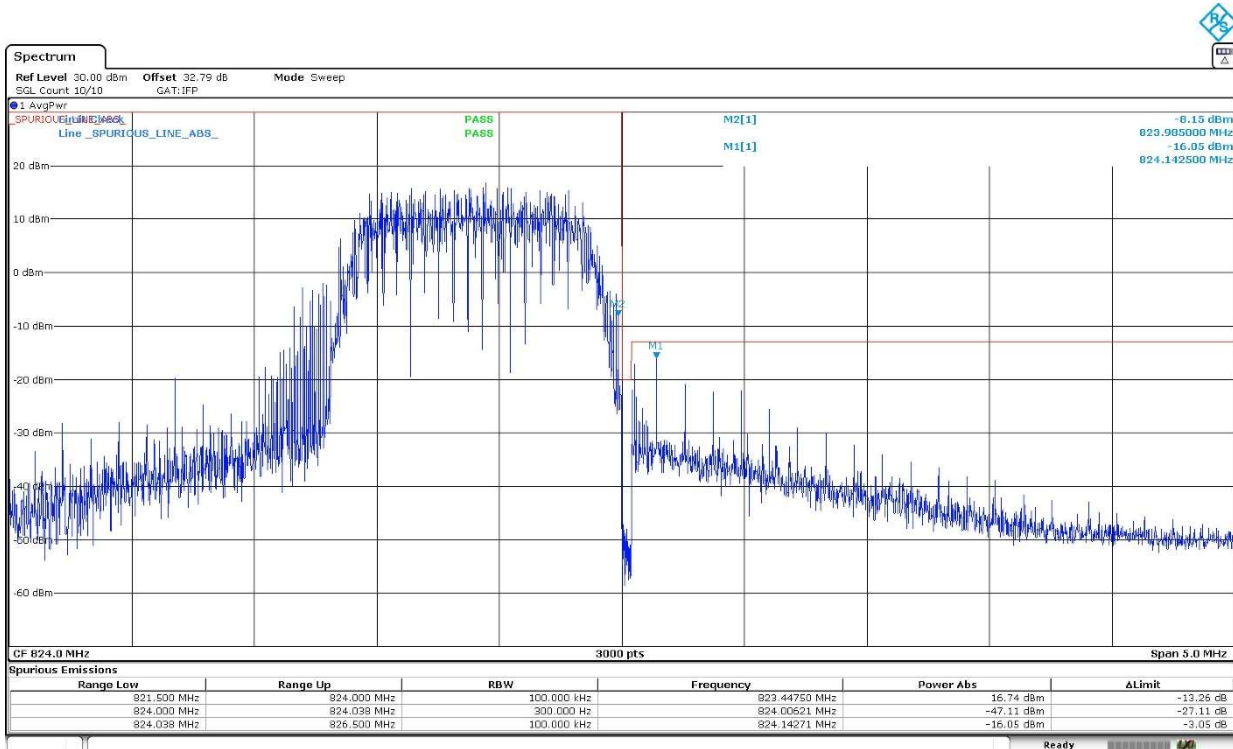

Radiated Emissions

Limits

FCC §90.691:

For any frequency removed from the EA licensee's frequency block greater than 37.5 kHz, the power of any emission shall be attenuated below the transmitter power (P) in watts by at least $43 + 10 \log_{10}(P)$ decibels or 80 decibels, whichever is the lesser attenuation, where f is the frequency removed from the center of the outer channel in the block in kilohertz and where f is greater than 37.5 kHz.

Method

The measurement was performed with the EUT inside an anechoic chamber. The spectrum was scanned from 30 MHz to at least the 10th harmonic of the High frequency generated within the equipment.

The EUT was placed on a 1 meter high non-conductive stand at a 3 meter distance from the measuring antenna. Detected emissions were maximized at each frequency by rotating the EUT and adjusting the height and polarization of the measuring antenna. The maximum meter reading was recorded.

MEASUREMENT LIMIT:

According to specification, the power of emissions shall be attenuated below the transmitter power (P) by a factor of at least $43 + 10 \log(P)$ dB, P in watts.

At P_o transmitting power, the specified minimum attenuation becomes $43 + 10 \log(P_o)$, and the level in dBm relative P_o becomes:

$$P_o \text{ (dBm)} - [43 + 10 \log(P_o \text{ in mwatts}) - 30] = -13 \text{ dBm}$$

The maximum field strength (dB μ V/m) of each detected emission at less than 20 dB respect to the limit is converted to an equivalent EIRP level (dBm) according to ANSI C63.26 with the formula:

$EIRP \text{ (dBm)} = E \text{ (dB}\mu\text{V/m)} + 20 \log(D) - 104.8$; where D is the measurement distance (in the far field region) in m. D = 3 m

A resolution bandwidth / video bandwidth of 100 kHz / 300 kHz was used for frequencies below 1 GHz and 1 MHz / 3 MHz for frequencies above 1 GHz.

Test Setup

Radiated measurements below 1 GHz:

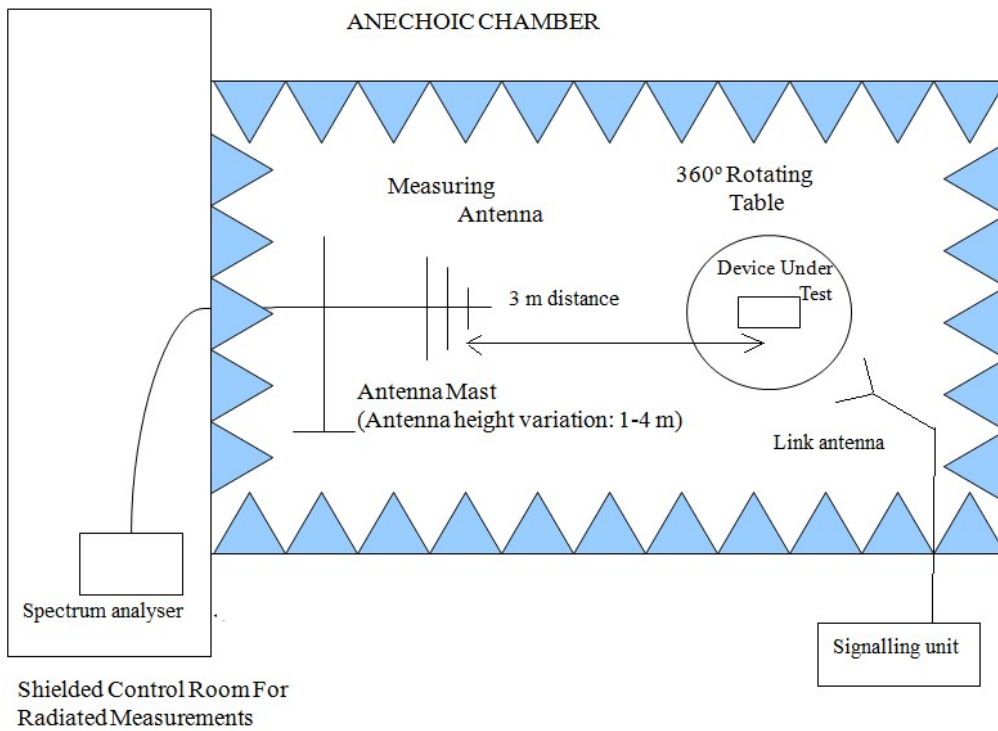

Radiated measurements above 1 GHz:

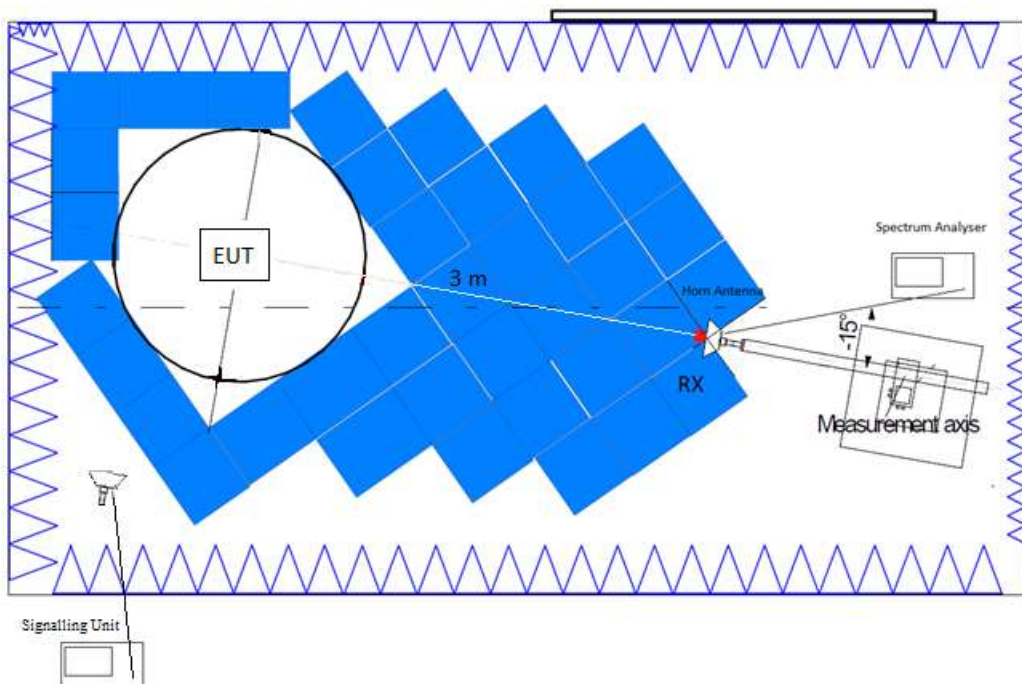

Results

Measurements required on one frequency near top channel and one frequency near bottom channel, according to FCC § 15.31 (m).

LTE Cat-M1 Band 26. Sub-band 814-824 MHz:

A preliminary scan determined the BW=10 MHz, 16QAM. RB Size=3, RB Offset=1, Narrow Band=0 as the worst-case. The next results are for this worst-case configuration.

- MIDDLE CHANNEL:

Frequency range 30 MHz - 1 GHz

No spurious frequencies at less than 20 dB below the limit.

Frequency range 1 - 8.5 GHz

No spurious frequencies at less than 20 dB below the limit.

Measurement uncertainty (dB): < ± 5.35 for $f \geq 30$ MHz up to 1 GHz
< ± 4.32 for $f \geq 1$ GHz up to 8.5 GHz

Verdict

Pass

LTE Cat-M1 Band 26. Sub-band 814-824 MHz:

FREQUENCY RANGE 30 MHz - 1 GHz:

- MIDDLE CHANNEL:

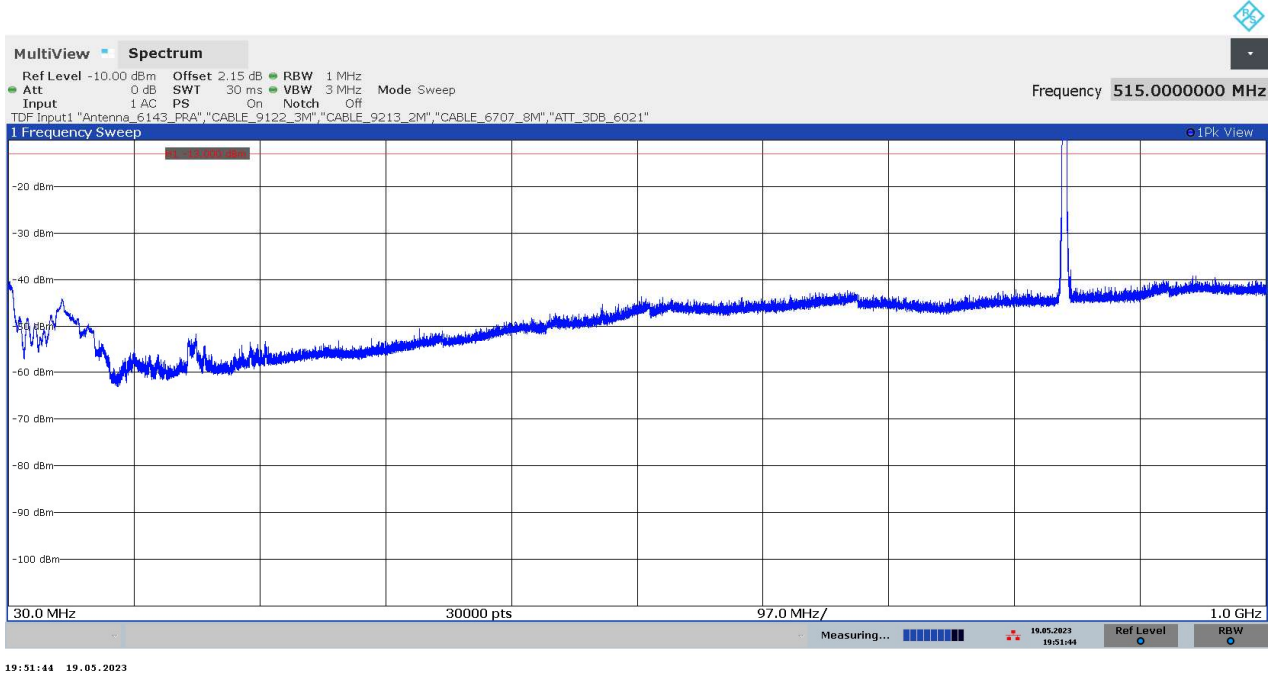

The peak above the limit is the carrier frequency:
LTE Cat-M1 Band 26, 819 MHz

FREQUENCY RANGE 1 - 8.5 GHz:

- MIDDLE CHANNEL:

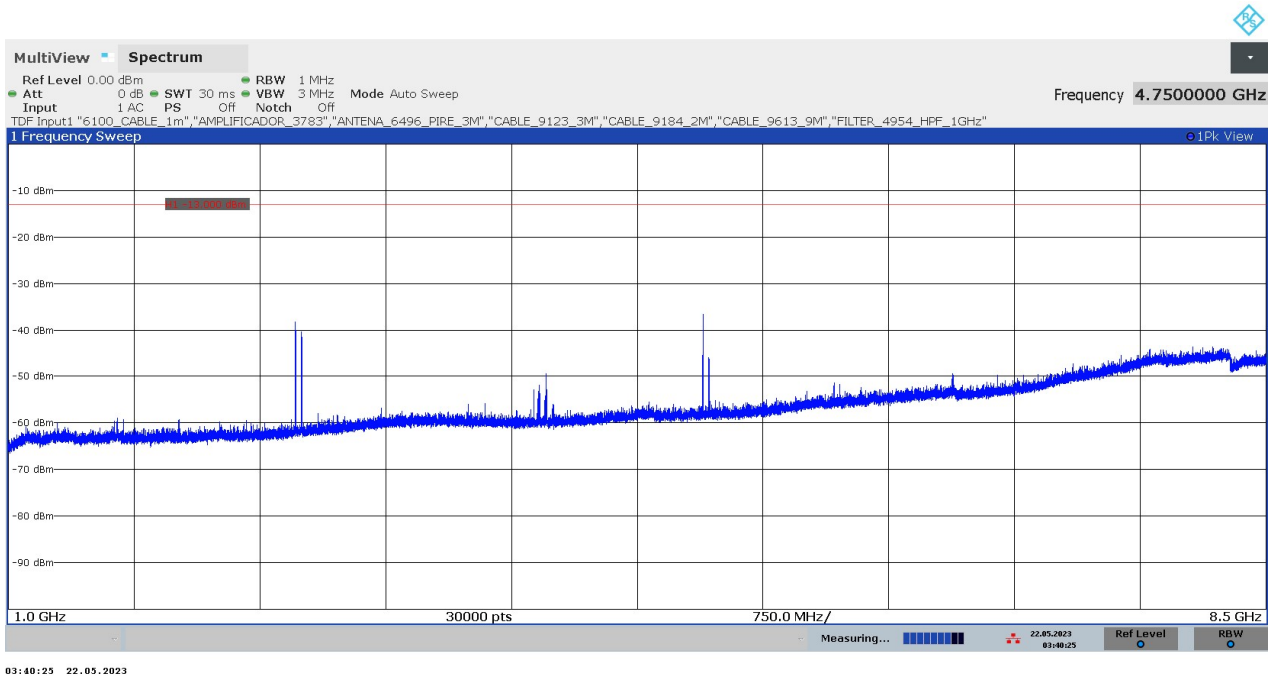

LTE Cat-M1 Band 26. Cross-rule Channel 824 MHz:

A preliminary scan determined the 16QAM, BW=10 MHz, RB Size=1, RB Offset=0, Narrow Band=5 as the worst case. The next results are for this worst-case configuration.

- SINGLE CHANNEL (Cross-rule Channel 824 MHz):

Frequency range 30 MHz - 1 GHz:

No spurious frequencies at less than 20 dB below the limit.

Frequency range 1 - 8.5 GHz:

No spurious frequencies at less than 20 dB below the limit.

Measurement uncertainty (dB): < ± 5.35 for $f \geq 30$ MHz up to 1 GHz
< ± 4.32 for $f \geq 1$ GHz up to 8.5 GHz

Verdict

Pass

LTE Cat-M1 Band 26. Cross-rule Channel 824 MHz:

FREQUENCY RANGE 30 MHz - 1 GHz:

- SINGLE CHANNEL (Cross-rule Channel 824 MHz):

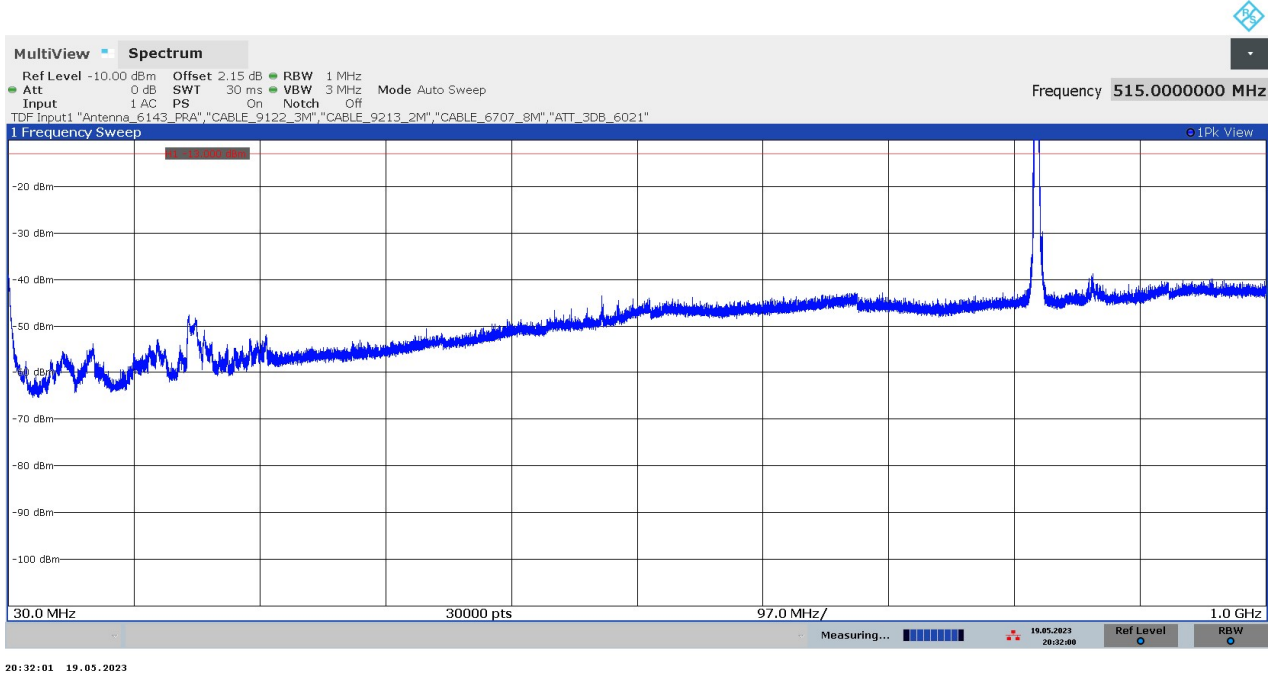

The peak above the limit is the carrier frequency:
 LTE Cat-M1 Band 26, 824 MHz

FREQUENCY RANGE 1 - 8.5 GHz:

- SINGLE CHANNEL (Cross-rule Channel 824 MHz):

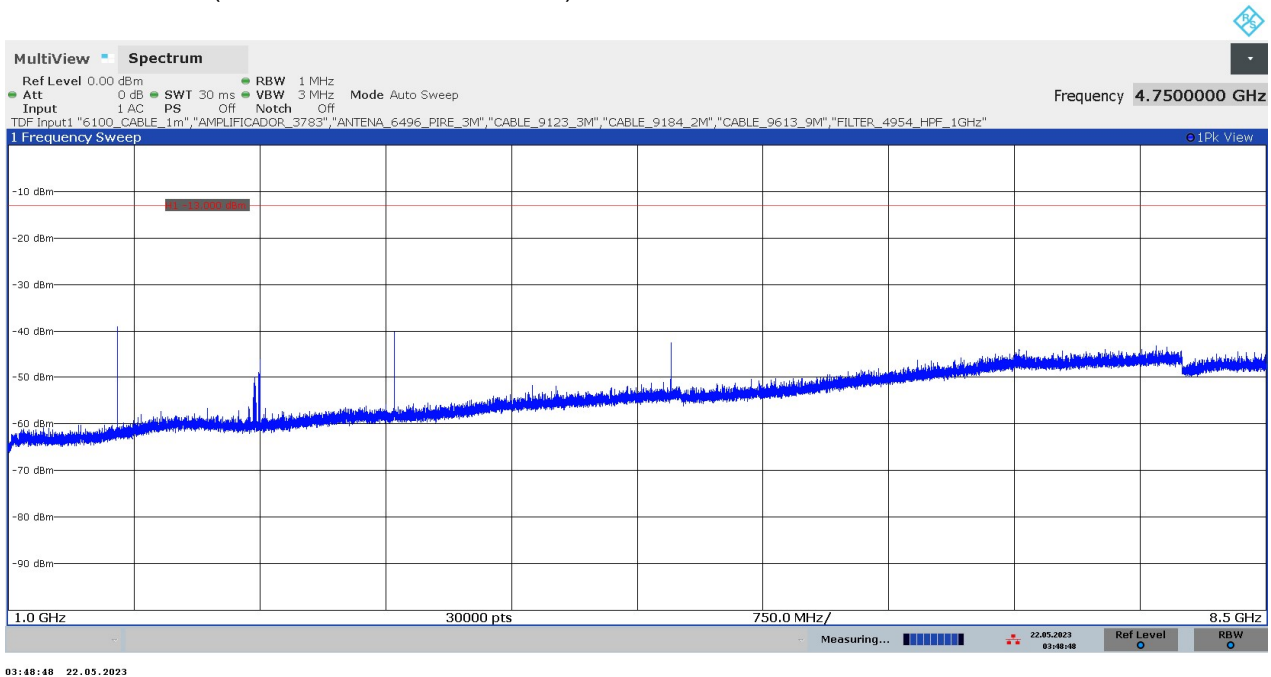

Appendix B: Test results for FCC 90: LTE Cat NB1 Band 26

INDEX

TEST CONDITIONS	41
RF Output Power	42
Frequency Stability	45
Modulation Characteristics	49
Occupied Bandwidth	51
Spurious emissions at antenna terminals	66
Spurious Emissions at Antenna Terminals at Block Edges	71
Radiated Emissions	76

TEST CONDITIONS

(*): Declared by the Applicant.

POWER SUPPLY (*):

Vnormal: 5 Vdc.
 Vmin 3 Vdc
 Vmax 5.5 Vdc
 Type of Power Supply: Internal DC.

ANTENNA (*):

Bands	Gain (dBi)	Type
LTE 26	+2.7	SMD

TEST FREQUENCIES:

LTE Cat NB1 Band 26. Sub-band 814-824 MHz. Pi/2-BPSK, Pi/4-QPSK, QPSK modulations:

Channel. Number (Frequency, MHz)		
Low	Middle	High
26692 (814.2)	26740 (819)	26788 (823.8)

LTE Cat NB1 Band 26. Cross-rule Channel (824 MHz). Pi/2-BPSK, Pi/4-QPSK, QPSK modulations:

Channel. Number (Frequency, MHz)
Low
26790 (824)

RF Output Power

Limits

FCC §90.635 (b): The maximum output power of the transmitter for mobile stations is 100 Watts (20 dBW).

Method

The conducted RF output power measurements were made at the RF output terminals of the EUT using the power meter of the Universal Radio Communication tester R&S CMW500, selecting maximum transmission power of the EUT and different modes of modulation.

The maximum equivalent isotropically radiated power (e.i.r.p.) is calculated by adding the declared maximum antenna gain (dBi).

The maximum effective radiated power e.r.p. is calculated from the maximum equivalent isotropically radiated power (e.i.r.p.) by subtracting 2.15 dB:

$$\text{E.R.P.} = \text{E.I.R.P.} - 2.15 \text{ dB}$$

Test Setup



Results

1. CONDUCTED AVERAGE POWER:

Measurements required on one frequency near top channel and one frequency near bottom channel, according to FCC § 15.31 (m).

LTE Cat NB1 Band 26. Sub-band 814-824 MHz:

Worst-case of RF Power is High Channel, Pi/2-BPSK, BW=15 kHz, Tone Number=1, Tone Offset=11, MSC/TBS=0.

CHANNEL	FREQUENCY (MHz)	MODULATION	BW	Tone Number	Tone Offset (Start SubCarrier)	MCS / TBS	AVERAGE POWER (dBm)
Low 26692	814.2 MHz	Pi/2-BPSK	3.75 kHz	1	0	0	23.13
				1	47	0	22.99
		15 kHz	1	0	0	23.05	
			1	11	0	23.04	
		Pi/4-QPSK	3.75 kHz	1	0	3	23.21
				1	47	3	23.07
	15 kHz	1	0	3	22.89		
		1	11	3	22.96		
	QPSK	15 kHz	3	0	5	22.64	
			3	6	5	22.84	
			6	0	5	22.06	
			6	6	5	21.84	
12	0	5	20.73				
Middle 26740	819 MHz	Pi/2-BPSK	3.75 kHz	1	0	0	23.10
				1	47	0	22.97
		15 kHz	1	0	0	23.02	
			1	11	0	22.96	
		Pi/4-QPSK	3.75 kHz	1	0	3	22.93
				1	47	3	23.10
	15 kHz	1	0	3	22.87		
		1	11	3	22.80		
	QPSK	15 kHz	3	0	5	22.61	
			3	6	5	22.81	
			6	0	5	21.94	
			6	6	5	21.96	
12	0	5	20.76				
High 26788	823.8 MHz	Pi/2-BPSK	3.75 kHz	1	0	0	23.12
				1	47	0	23
		15 kHz	1	0	0	23.08	
			1	11	0	23.22	
		Pi/4-QPSK	3.75 kHz	1	0	3	23.14
				1	47	3	22.96
	15 kHz	1	0	3	22.85		
		1	11	3	22.97		
	QPSK	15 kHz	3	0	5	22.63	
			3	6	5	22.65	
			6	0	5	22.01	
			6	6	5	21.85	
12	0	5	20.93				

MAX POWER	COND. POWER AVG (dBm)	ANTENNA GAIN (dBi)	RAD. POWER AVG (dBm)	RAD. POWER AVG ERP (dBm)
LOW	23.04	2.7	25.74	23.59
MIDDLE	22.97	2.7	25.67	23.52
HIGH	23.22	2.7	25.92	23.77
MAX:	23.22		25.92	

Verdict

Pass

LTE Cat NB1 Band 26. Cross-rule Channel 824 MHz:

Worst-case of RF Power is High Channel, Pi/2-BPSK, BW=15 kHz, Tone Number=1, Tone Offset=11, MSC/TBS=0.

CHANNEL	FREQUENCY (MHz)	MODULATION	BW	Tone Number	Tone Offset (Start SubCarrier)	MCS / TBS	AVERAGE POWER (dBm)
26790	824 MHz	Pi/2-BPSK	3.75 kHz	1	0	0	22,66
				1	47	0	22,56
			15 kHz	1	0	0	22,72
				1	11	0	22,71
		Pi/4-QPSK	3.75 kHz	1	0	3	22,59
				1	47	3	22,55
			15 kHz	1	0	3	22,66
				1	11	3	22,66
		QPSK	15 kHz	3	0	5	22,44
				3	6	5	22,58
				6	0	5	21,84
				6	6	5	21,81
				12	0	5	20,83

Verdict

Pass

Frequency Stability

Limits

FCC § 90.213: Frequency stability.

The applicant shall ensure frequency stability by showing that f_L minus the frequency offset and f_H plus the frequency offset shall be within the frequency range in which the equipment is designed to operate.

Method

The frequency tolerance measurements over temperature variations were made over the temperature range of -30°C to $+50^{\circ}\text{C}$. The EUT was placed inside a climatic chamber and the temperature was raised hourly in 10°C steps from -30°C up to $+50^{\circ}\text{C}$.

The supply voltage was varied between 85% and 115% of nominal voltage.

The EUT was set in "Radio Resource Control (RRC) mode" in the middle channel using the Universal Radio Communication tester R&S CMW500 and the maximum frequency error was measured using the built-in calibrated frequency meter.

The worst case LTE mode for conducted power was used for the test.

In order to check that the frequency stability is sufficient such that the fundamental emissions stay within the authorized bands of operation, a reference point is established at the applicable unwanted emissions limit using a RBW equal to the RBW required by the unwanted emissions specification of the applicable regulatory standard. These reference points measured using the Low and High channel of operation are identified as f_L and f_H respectively. The worst-case frequency offset determined in the above methods is added or subtracted from the values of f_L and f_H to check that the resulting frequencies remain within the band.

The reference point measurements were made at the RF output terminals of the EUT using an attenuator, power splitter and spectrum analyser. The EUT was controlled via the Universal Radio Communication tester R&S CMW500 selecting maximum transmission power of the EUT and different modes of modulation.

Test Setup

1. Frequency Tolerance:

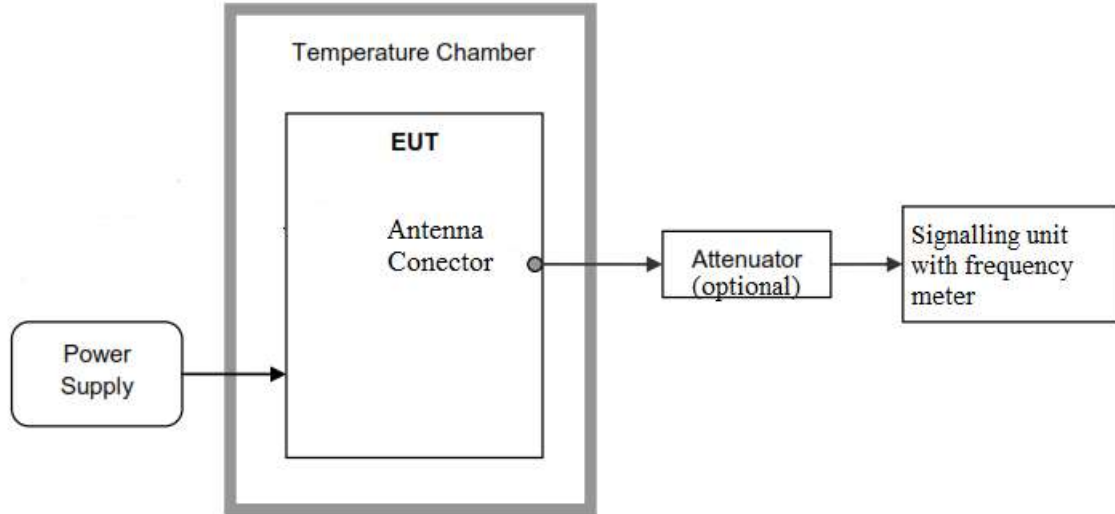

3. Reference Frequency Points f_L and f_H :

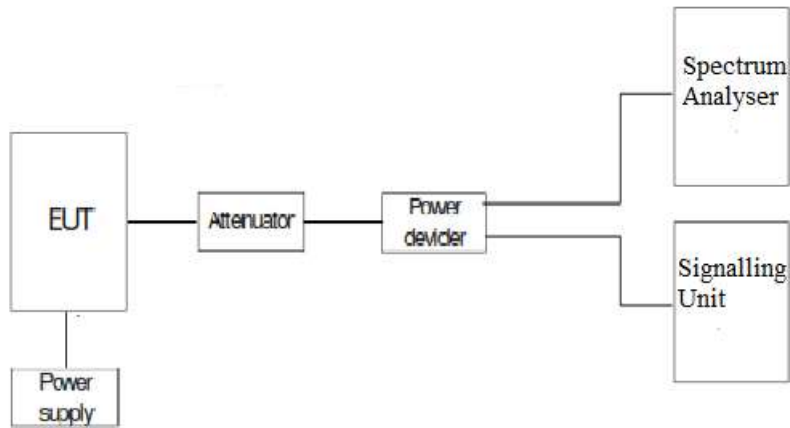

Results

LTE Cat NB1 Band 26. Sub-band 814-824 MHz:

The worst case modulation in terms of Frequency Stability is QPSK, BW=15 kHz, Tone Number=3, Tone Offset=6, MSC/TBS=5.

1. Frequency Tolerance:

- **Frequency Stability over Temperature Variations:**

Temperature (°C)	Frequency Error (Hz)	Frequency Error (ppm)
+85	16.35	0,01996337
+80	-8.76	-0,010695971
+70	-8.64	-0,010549451
+60	-5.42	-0,006617827
+50	-0.73	-0.000891331
+40	-9.78	-0.011941392
+30	-8.1	-0.00989011
+20	-10.13	-0.012368742
+10	-5.82	-0.007106227
0	7.02	0.008571429
-10	-10.09	-0.012319902
-20	10.34	0.012625153
-30	13.92	0.016996337
-40	-16.92	-0,020659341

- **Frequency Stability over Voltage Variations.**

Battery Supply voltage	Voltage (V)	Frequency Error (Hz)	Frequency Error (ppm)
Vmax	5.5	-9	-0.010989011
Vmin (*)	3	-3.65	-0.004456654

(*): Operating end point specified by the manufacturer.

3. Reference Frequency Points fL and fH:

The worst-case frequency offsets added or subtracted per band and bandwidth:

fL (MHz)	814.0009
fH (MHz)	823.9985

The reference frequency points fL and fH stay within the authorized blocks for all the band above.

Measurement uncertainty (Hz) $<\pm 249.55$

Results

PASS

Modulation Characteristics

Limits

FCC §2.1047 Measurements required: Modulation characteristics.

Method

For LTE the EUT operates with QPSK and 16QAM modes in which the information is digitised and coded into a bit stream. The RF transmission is multiplexed using *Orthogonal Frequency Division Multiplexing (OFDM)* using different possible arrangement of subcarriers (Resource Blocks RB).

Test Setup

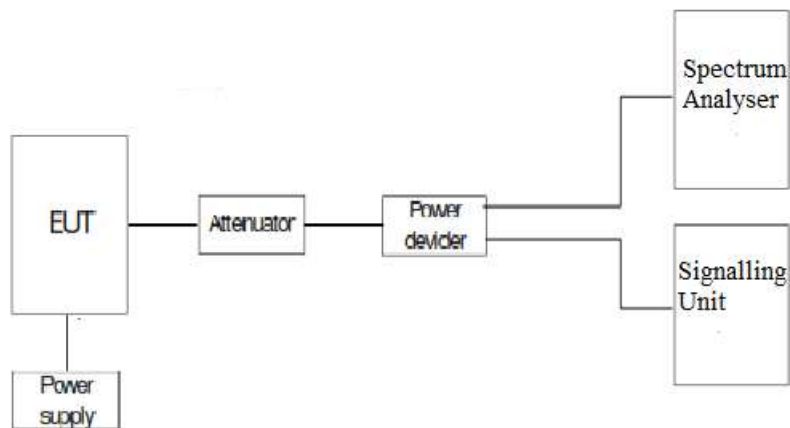

Results

The following plots show the modulation schemes in the EUT.

LTE Cat NB1 Band 26. Sub-band 814-824 MHz: Pi/4-QPSK. Middle Channel. BW=3.75 kHz. Tone Number=1. Tone Offset=0. MSC/TBS=3.

