

Test Report No:
75755RRF.005A1

Test Report

USA FCC Part 90

(*) Identification of item tested	nRF91
(*) Trademark	nRF91
(*) Model and /or type reference	nRF9161
Other identification of the product	FCC ID: 2ANPO00nRF9161 IC: 24529-NRF9161
(*) Features	LTE Cat-M1, LTE NB1&NB2 HW version: nRF9161 LACA A0A SW version: mfw_nrf91x1_2.0.0-77.beta
Applicant	NORDIC SEMICONDUCTOR ASA Otto Niensens Veg 12, 7052 Trondheim, Norway
Test method requested, standard	USA FCC Part 90 (10-1-21 Edition). ANSI C63.26-2015. KDB 971168 D01 Power Meas License Digital Systems v03r01, April. 2018.
Summary	IN COMPLIANCE
Approved by (name / position & signature)	José Manuel Gómez Galván EMC Consumer & RF Lab. Manager
Date of issue	2023-11-30
Report template No	FDT08_24 (*) "Data provided by the client"

Index

Competences and guarantees	3
General conditions	3
Uncertainty	3
Data provided by the client.....	3
Usage of samples	4
Test sample description	4
Identification of the client.....	5
Testing period and place.....	5
Document history	5
Environmental conditions	5
Remarks and comments	6
Testing verdicts.....	7
Summary	7
Appendix A: Test results for FCC 90: LTE Cat-M1 Band 26.....	8
Appendix B: Test results for FCC 90: LTE Cat NB1 Band 26	39

Competences and guarantees

DEKRA Testing and Certification is a testing laboratory accredited by the National Accreditation Body (ENAC - Entidad Nacional de Acreditación) to perform the tests indicated in the Certificate No. 51/LE 147.

DEKRA Testing and Certification is an FCC-recognized accredited testing laboratory with appropriate scope of accreditation that covers the performed tests in this report.

In order to assure the traceability to other national and international laboratories, DEKRA Testing and Certification has a calibration and maintenance program for its measurement equipment.

DEKRA Testing and Certification guarantees the reliability of the data presented in this report, which is the result of the measurements and the tests performed to the item under test on the date and under the conditions stated on the report and it is based on the knowledge and technical facilities available at DEKRA Testing and Certification at the time of performance of the test.

DEKRA Testing and Certification is liable to the client for the maintenance of the confidentiality of all information related to the item under test and the results of the test.

The results presented in this Test Report apply only to the particular item under test established in this document.

IMPORTANT: No parts of this report may be reproduced or quoted out of context, in any form or by any means, except in full, without the previous written permission of DEKRA Testing and Certification.

General conditions

1. This report is only referred to the item that has undergone the test.
2. This report does not constitute or imply on its own an approval of the product by the Certification Bodies or competent Authorities.
3. This document is only valid if complete; no partial reproduction can be made without previous written permission of DEKRA Testing and Certification S.A.U.
4. This test report cannot be used partially or in full for publicity and/or promotional purposes without previous written permission of DEKRA Testing and Certification S.A.U. and the Accreditation Bodies.

Uncertainty

Uncertainty (factor $k=2$) was calculated according to the DEKRA Testing and Certification S.A.U. internal document PODT000.

Data provided by the client

The following data has been provided by the client:

1. Information relating to the description of the sample ("Identification of the item tested", "Trademark", "Model and/or type reference tested").
2. The sample model nRF9161 is a Development Kit that has nRF9161 IOT Module and GPS. The nRF9161 is capable of LTE Cat-M1, Cat-NB1&NB2 and GPS. The Development kit contains antennas for cellular and GPS.

DEKRA Testing and Certification S.A.U. declines any responsibility with respect to the information provided by the client and that may affect the validity of results.

Usage of samples

Samples undergoing test have been selected by: The client.

- Sample S/01 is composed of the following elements:

Control N°	Description	Model	Serial N°	Date of reception
75755B/005	nRF91	nRF9161	359746166778998	11-05-2023
75755B/007	USB Cable	-	-	11-05-2023

Sample S/01 has undergone the following test(s): The radiated tests indicated in Appendix A and B.

- Sample S/02 is composed of the following elements:

Control N°	Description	Model	Serial N°	Date of reception
75755B/003	nRF91	nRF9161	359746166783618	11-05-2023
75755B/007	USB Cable	-	-	11-05-2023
75755B/011	Antenna Cable SMA	-	-	11-05-2023

Sample S/02 has undergone the following test(s): The conducted tests indicated in Appendix A and B.

Test sample description

Ports.....:	Port name and description		Cable				
			Specified max length [m]	Attached during test	Shielded	Coupled to patient ⁽³⁾	
	LTE RF	2	<input checked="" type="checkbox"/>	<input checked="" type="checkbox"/>	<input type="checkbox"/>		
	GPS	2	<input type="checkbox"/>	<input type="checkbox"/>	<input type="checkbox"/>		
Supplementary information to the ports.....:	-						
Rated power supply	Voltage and Frequency		Reference poles				
			L1	L2	L3	N	PE
	<input type="checkbox"/>	AC:	<input type="checkbox"/>	<input type="checkbox"/>	<input type="checkbox"/>	<input checked="" type="checkbox"/>	<input type="checkbox"/>
	<input type="checkbox"/>	AC:	<input type="checkbox"/>	<input type="checkbox"/>	<input type="checkbox"/>	<input checked="" type="checkbox"/>	<input type="checkbox"/>
	<input checked="" type="checkbox"/>	DC: 3.0-5.5V					
<input type="checkbox"/>	DC:						
Rated Power..... :	1W						
Clock frequencies..... :	32kHz, 32MHz						
Other parameters	-						
Software version..... :	mfw_nrf91x1_2.0.0-77.beta						
Hardware version	nRF9161 LACA A0A						
Dimensions in cm (W x H x D) ... :	155x64x9mm						
Mounting position	<input checked="" type="checkbox"/>	Table top equipment					
	<input type="checkbox"/>	Wall/Ceiling mounted equipment					
	<input type="checkbox"/>	Floor standing equipment					
	<input type="checkbox"/>	Hand-held equipment					
	<input type="checkbox"/>	Other:					

Modules/parts..... :	Module/parts of test item	Type	Manufacturer
	-	-	-
Accessories (not part of the test item)..... :	Description	Type	Manufacturer
	-	-	-
Documents as provided by the applicant..... :	Description	File name	Issue date
	-	-	-

⁽³⁾ Only for Medical Equipment

Identification of the client

NORDIC SEMICONDUCTOR ASA
 Otto Nielsens Vel 12, 7052 Trondheim, Norway

Testing period and place

Test Location	DEKRA Testing and Certification S.A.U.
Date (start)	2023-05-15
Date (finish)	2023-08-10

Document history

Report number	Date	Description
75755RRF.005	2023-11-301	First release.
75755RRF.005A1	2023-11-27	Second release. Minor typos corrected. This release cancels and replaces 75755RRF.005.

Environmental conditions

In the control chamber, the following limits were not exceeded during the test:

Temperature	Min. = 15 °C Max. = 35 °C
Relative humidity	Min. = 20 % Max. = 75 %

In the semi-anechoic chamber, the following limits were not exceeded during the test:

Temperature	Min. = 15 °C Max. = 35 °C
Relative humidity	Min. = 20 % Max. = 75 %

In the chamber for conducted measurements, the following limits were not exceeded during the test:

Temperature	Min. = 15 °C Max. = 35 °C
--------------------	------------------------------

Relative humidity	Min. = 20 % Max. = 75 %
--------------------------	----------------------------

Remarks and comments

The tests have been performed by the technical personnel: Rafael Fernández, Sergio Carrasco, Alberto Agüera, Valentín Andarias, Carmen Vázquez, Ireneo Bibang, Pablo Redondo.

Used instrumentation:

Control No.	Equipment	Model	Manufacturer	Next Calibration
6794	Shielded Room	S101	ETS LINDGREN	N/A
9229	Wideband Radio Communication Tester	CMW500	ROHDE AND SCHWARZ	2024-06
7794	Signal and Spectrum Analyzer 10 Hz - 40 GHz	FSV40	ROHDE AND SCHWARZ	2025-04
2215	Power Divider DC-25 GHz	5333-104	PICOSECOND PULSE LABS	2024-07
8002	TEMPERATURE CHAMBER MK56 BINDER	MK 56	BINDER	2024-04
5880	DC POWER SUPPLY 30V/5A	U8002A	KEYSIGHT TECHNOLOGY	N/A
5850	DIGITAL MULTIMETER	179	DIGITAL MULTIMETER	2023-11
6791	SEMIANECHOIC ABSORBER LINED	FACT 3 200 STP	ETS LINDGREN	N/A
6792	SHIELDED ROOM	S101	ETS LINDGREN	N/A
6143	Biconical/Log Antenna 30 MHz - 6 GHz	3142E	ETS LINDGREN	2023-10
6496	HORN ANTENNA 1-18GHz	BBHA 9120 D	SCHWARZBECK	2023-08
7817	EMI TEST RECEIVER 2Hz-44GHz	ESW44	ROHDE AND SCHWARZ	2023-12
3783	PRE-AMPLIFIER G>30dB 1GHz-18GHz	BLMA 0118-3A	BONN ELEKTRONIK	2023-12
8912	Wideband Radio Communication Tester	CMW500	ROHDE AND SCHWARZ	2023-09
7798	EMC/RF MEASUREMENT SOFTWARE	WMS32	ROHDE AND SCHWARZ	N/A
4848	SOFTWARE FOR EMC/RF TESTING	EMC32	ROHDE AND SCHWARZ	N/A

Testing verdicts

Not applicable:	N/A
Pass:	P
Fail:	F
Not measured:	N/M

Summary

Appendix A: LTE Cat-M1 Band 26.

FCC PART 90		
Requirement – Test case	Verdict	Remark
FCC 90.635 (b): RF output power	P	
FCC 2.1047: Modulation characteristics	P	
FCC 90.213: Frequency stability	P	
FCC 2.1049: Occupied Bandwidth	P	
FCC 90.691: Spurious emissions at antenna terminals	P	
FCC 90.691: Spurious emissions at antenna terminals (Emission mask requirements for EA-based systems)	P	
FCC 90.691: Radiated emissions	P	
<u>Supplementary information and remarks:</u> None.		

Appendix B: LTE Cat NB1 Band 26.

FCC PART 90		
Requirement – Test case	Verdict	Remark
FCC 90.635 (b): RF output power	P	
FCC 2.1047: Modulation characteristics	P	
FCC 90.213: Frequency stability	P	
FCC 2.1049: Occupied Bandwidth	P	
FCC 90.691: Spurious emissions at antenna terminals	P	
FCC 90.691: Spurious emissions at antenna terminals (Emission mask requirements for EA-based systems)	P	
FCC 90.691: Radiated emissions	P	
<u>Supplementary information and remarks:</u> None.		

Appendix A: Test results for FCC 90: LTE Cat-M1 Band 26

INDEX

TEST CONDITIONS.....	10
RF Output Power	11
Frequency Stability	14
Modulation Characteristics	18
Occupied Bandwidth.....	20
Spurious emissions at antenna terminals	25
Spurious Emissions at Antenna Terminals at Block Edges	29
Radiated Emissions	33

TEST CONDITIONS

(*): Declared by the Applicant.

POWER SUPPLY (*):

Vnormal: 5 Vdc.
 Vmin 3 Vdc
 Vmax 5.5 Vdc
 Type of Power Supply: Internal DC.

ANTENNA (*):

Bands	Gain (dBi)	Type
LTE 26	+2.7	SMD

TEST FREQUENCIES:

LTE Cat-M1 Band 26. Sub-band 814-824 MHz. QPSK and 16QAM:

	Channel (Frequency, MHz)				
	BW=1.4 MHz	BW=3 MHz	BW=5 MHz	BW=10 MHz	BW=15 MHz
Low	26697 (814.7)	26705 (815.5)	26715 (816.5)	N/A	N/A
Middle	26740 (819)	26740 (819)	26740 (819)	26740 (819)	N/A
High	26783 (823.3)	26775 (822.5)	26765 (821.5)	N/A	N/A

LTE Cat-M1 Band 26. Cross-rule Channel (824 MHz). QPSK and 16QAM:

Channel (Frequency, MHz)				
BW=1.4 MHz	BW=3 MHz	BW=5 MHz	BW=10 MHz	BW=15 MHz
26790 (824)	26790 (824)	26790 (824)	26790 (824)	26790 (824)

RF Output Power

Limits

FCC §90.635 (b): The maximum output power of the transmitter for mobile stations is 100 Watts (20 dBW).

Method

The conducted RF output power measurements were made at the RF output terminals of the EUT using the power meter of the Universal Radio Communication tester R&S CMW500, selecting maximum transmission power of the EUT and different modes of modulation.

The maximum equivalent isotropically radiated power (e.i.r.p.) is calculated by adding the declared maximum antenna gain (dBi).

The maximum effective radiated power e.r.p. is calculated from the maximum equivalent isotropically radiated power (e.i.r.p.) by subtracting 2.15 dB:

$$E.R.P. = E.I.R.P. - 2.15 \text{ dB}$$

Test Setup



Results

CONDUCTED AVERAGE POWER:

Measurements required on one frequency near top channel and one frequency near bottom channel, according to FCC § 15.31 (m).

LTE Cat-M1 Band 26. Sub-band 814-824 MHz:

Worst-case of RF Power is BW=10 MHz, Middle Channel, 16QAM, RB Size=3, RB Offset=1, Narrow Band=0.

BANDWIDTH (MHz)	CHANNEL	FREQUENCY (MHz)	MODULATION	RB SIZE	RB OFFSET	AVERAGE POWER (dBm)
10	Middle 26740	819	QPSK	1	0	22.49
				1	2	22.51
				1	5	22.52
				3	0	22.5
				3	1	22.51
				3	3	22.51
				6	0	21.47
			16QAM	1	0	22.44
				1	2	22.47
				1	5	22.47
				3	0	22.78
				3	1	22.79
				3	3	22.65
				5	0	21.67

BW=10 MHz. QPSK:

MAX POWER	QPSK COND. POWER AVG (dBm)	ANTENNA GAIN (dBi)	RAD. POWER AVG EIRP(dBm)
MIDDLE	22.52	2.7	25.22
MAX:	22.52		25.22

BW=10 MHz. 16QAM:

MAX POWER	16QAM COND. POWER AVG (dBm)	ANTENNA GAIN (dBi)	RAD. POWER AVG EIRP(dBm)
MIDDLE	22.79	2.7	25.49
MAX:	22.79		25.49

LTE Cat-M1 Band 26. Cross-rule Channel 824 MHz:

Worst-case of RF Power is BW=15 MHz, Middle Channel, 16QAM, RB Size=1, RB Offset=0, Narrow Band=5.

BANDWIDTH (MHz)	CHANNEL	FREQUENCY (MHz)	MODULATION	RB SIZE	RB OFFSET	AVERAGE POWER (dBm)
15	Middle 26790	824	QPSK	1	0	22.64
				1	2	22.58
				1	5	22.58
				3	0	22.65
				3	1	22.65
				3	3	22.65
				6	0	22.67
			16QAM	1	0	23.27
				1	2	23.14
				1	5	23.13
				3	0	22.86
				3	1	22.85
				3	3	22.85
				5	0	22.72

BW=10 MHz. QPSK:

MAX POWER	QPSK COND. POWER AVG (dBm)	ANTENNA GAIN (dBi)	RAD. POWER AVG EIRP(dBm)
MIDDLE	22.67	2.7	25.37
MAX:	22.67		25.37

BW=10 MHz. 16QAM:

MAX POWER	16QAM COND. POWER AVG (dBm)	ANTENNA GAIN (dBi)	RAD. POWER AVG EIRP(dBm)
MIDDLE	23.27	2.7	25.97
MAX:	23.27		25.97

Measurement uncertainty (dB) <±1.11

Verdict

Pass

Frequency Stability

Limits

FCC § 90.213: Frequency stability.

The applicant shall ensure frequency stability by showing that f_L minus the frequency offset and f_H plus the frequency offset shall be within the frequency range in which the equipment is designed to operate.

Method

The frequency tolerance measurements over temperature variations were made over the temperature range of -30°C to $+50^{\circ}\text{C}$. The EUT was placed inside a climatic chamber and the temperature was raised hourly in 10°C steps from -30°C up to $+50^{\circ}\text{C}$.

The supply voltage was varied between 85% and 115% of nominal voltage.

The EUT was set in "Radio Resource Control (RRC) mode" in the middle channel using the Universal Radio Communication tester R&S CMW500 and the maximum frequency error was measured using the built-in calibrated frequency meter.

The worst case LTE mode for conducted power was used for the test.

In order to check that the frequency stability is sufficient such that the fundamental emissions stay within the authorized bands of operation, a reference point is established at the applicable unwanted emissions limit using a RBW equal to the RBW required by the unwanted emissions specification of the applicable regulatory standard. These reference points measured using the Low and High channel of operation are identified as f_L and f_H respectively. The worst-case frequency offset determined in the above methods is added or subtracted from the values of f_L and f_H to check that the resulting frequencies remain within the band.

The reference point measurements were made at the RF output terminals of the EUT using an attenuator, power splitter and spectrum analyser. The EUT was controlled via the Universal Radio Communication tester R&S CMW500 selecting maximum transmission power of the EUT and different modes of modulation.

Test Setup

1. Frequency Tolerance:

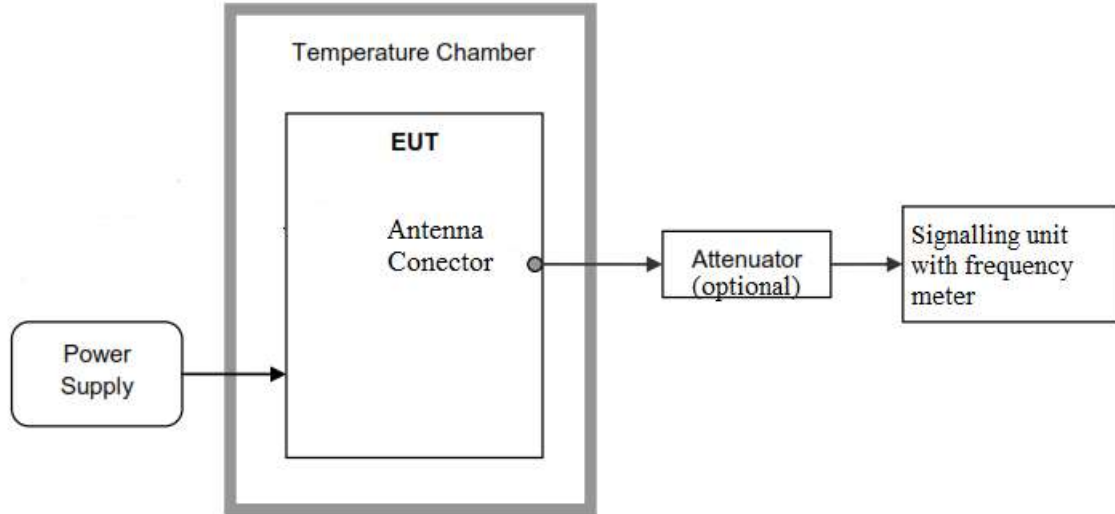

2. Reference Frequency Points f_L and f_H :

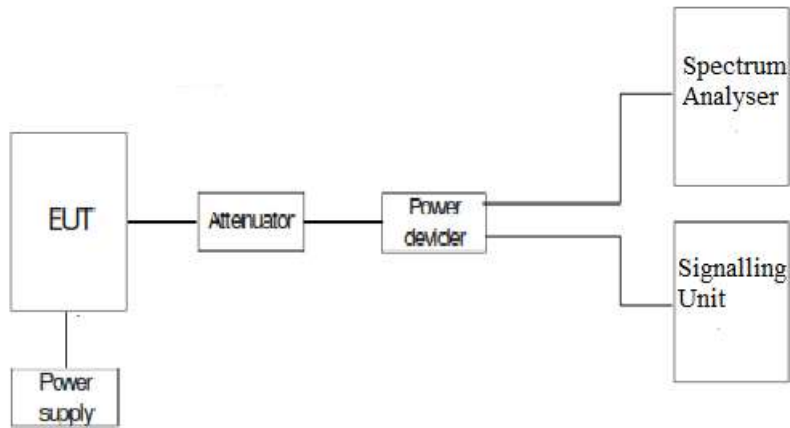

Results

LTE Cat-M1 Band 26. Sub-band 814-824 MHz:

The worst case modulation in terms of Frequency Stability is BW=10 MHz, QPSK.

1. Frequency Tolerance:

- **Frequency Stability over Temperature Variations:**

Temperature (°C)	Frequency Error (Hz)	Frequency Error (ppm)
85	0.11	0,00013431
80	5.42	0,006617827
70	-6.84	-0,008351648
60	2.-35	0,002869353
+50	-0.11	-0.00013431
+40	-7.84	-0.00957265
+30	4.55	0.005555556
+20	-4.78	-0.005836386
+10	-3.39	-0.004139194
0	-1.47	-0.001794872
-10	-4.11	-0.005018315
-20	-7.7	-0.009401709
-30	2.25	0.002747253
-40	-4.15	-0,005067155

- **Frequency Stability over Voltage Variations.**

Battery Supply voltage	Voltage (V)	Frequency Error (Hz)	Frequency Error (ppm)
Vmax	5.5	2.33	0.00284493
Vmin (*)	3	1.2	0.001465201

(*): Operating end point specified by the manufacturer.

2. Reference Frequency Points fL and fH:

The worst-case frequency offsets added or subtracted per band and bandwidth:

fL (MHz)	814.00414
fH (MHz)	823.98607

The reference frequency points fL and fH stay within the authorized blocks for all the band above.

Measurement uncertainty (Hz) $<\pm 249.55$

Results

PASS

Modulation Characteristics

Limits

FCC §2.1047 Measurements required: Modulation characteristics.

Method

For LTE the EUT operates with QPSK and 16QAM modes in which the information is digitised and coded into a bit stream. The RF transmission is multiplexed using *Orthogonal Frequency Division Multiplexing (OFDM)* using different possible arrangement of subcarriers (Resource Blocks RB).

Test Setup

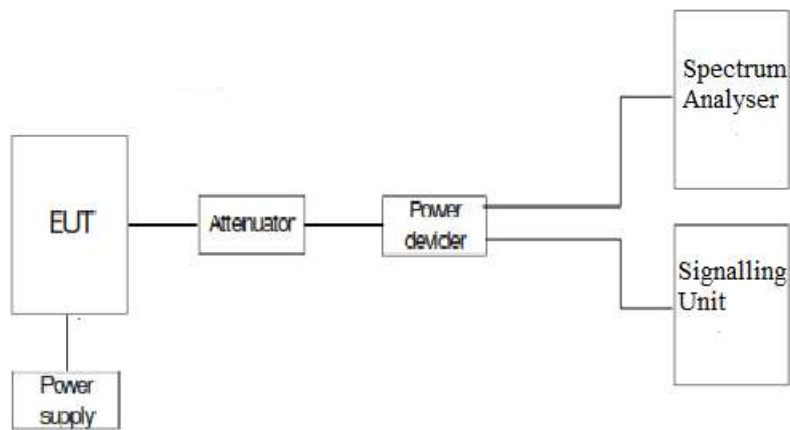

Results

The following plots show the modulation schemes in the EUT.

LTE Cat-M1 Band 26. Sub-band 814-824 MHz: BW = 10 MHz. QPSK.

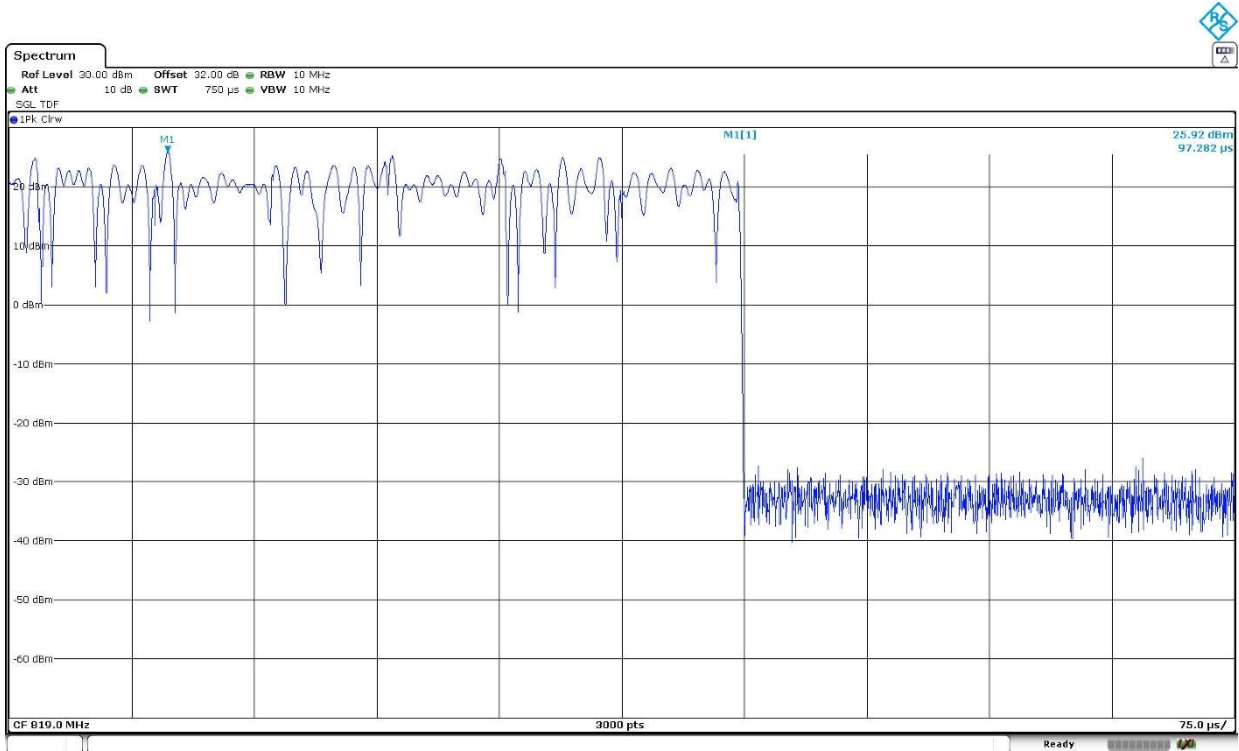

LTE Cat-M1 Band 26. Sub-band 814-824 MHz: BW = 10 MHz. 16QAM.

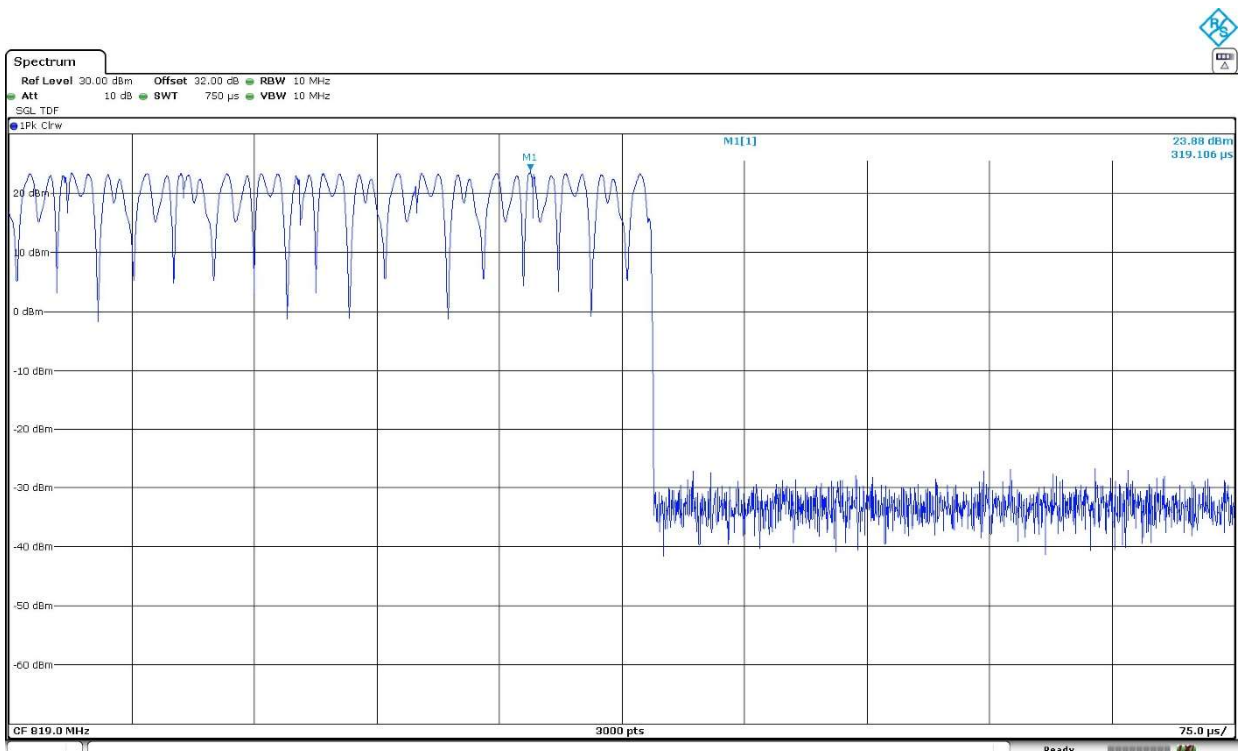

Occupied Bandwidth

Limits

FCC §2.1049. Measurements required: Occupied bandwidth.

Method

The occupied bandwidth measurement was performed at the output terminals of the EUT using an attenuator, power splitter and spectrum analyser. The EUT was controlled via the Universal Radio Communication tester R&S CMW500 selecting maximum transmission power of the EUT and different modes of modulation. The 99% occupied bandwidth and the -26 dBc bandwidth were measured directly using the built-in bandwidth measuring option of spectrum analyser.

Test Setup

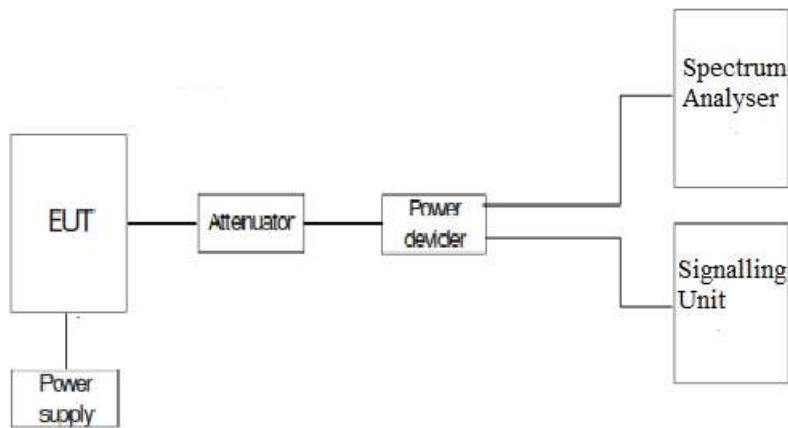

Results

LTE Bands: The worst case of Occupied Bandwidth corresponds to all Resource Blocks (RB) with Offset 0, regardless the nominal bandwidth selected.

LTE Cat-M1 Band 26. Sub-band 814-824 MHz:

LTE Cat-M1 Band 26. Sub-band 814-824 MHz. BW = 1.4 MHz. QPSK. RB Size = All.

	Low Channel	High Channel
99% Occupied Bandwidth (MHz)	1.11330	1.10820
-26 dBc Bandwidth (MHz)	1.44714	1.38989
Measurement uncertainty (kHz)	<±4.67	

LTE Cat-M1 Band 26. Sub-band 814-824 MHz. BW = 1.4 MHz. 16QAM. RB Size = All.

	Low Channel	High Channel
99% Occupied Bandwidth (MHz)	0.94440	0.94470
-26 dBc Bandwidth (MHz)	1.29412	1.28234
Measurement uncertainty (kHz)	<±4.67	

LTE Cat-M1 Band 26. Cross-rule Channel 824 MHz:

LTE Cat-M1 Band 26. Cross-rule Channel 824 MHz. BW = 1.4 MHz. QPSK. RB Size = All.

	Single Channel
99% Occupied Bandwidth (MHz)	1.10910
-26 dBc Bandwidth (MHz)	1.38705
Measurement uncertainty (kHz)	<±4.67

LTE Cat-M1 Band 26. Cross-rule Channel 824 MHz. BW = 1.4 MHz. 16QAM. RB Size = All.

	Single Channel
99% Occupied Bandwidth (MHz)	0.94530
-26 dBc Bandwidth (MHz)	1.29517
Measurement uncertainty (kHz)	<±4.67

LTE Cat-M1 Band 26. Sub-band 814-824 MHz. BW = 1.4 MHz. QPSK.

Low Channel:

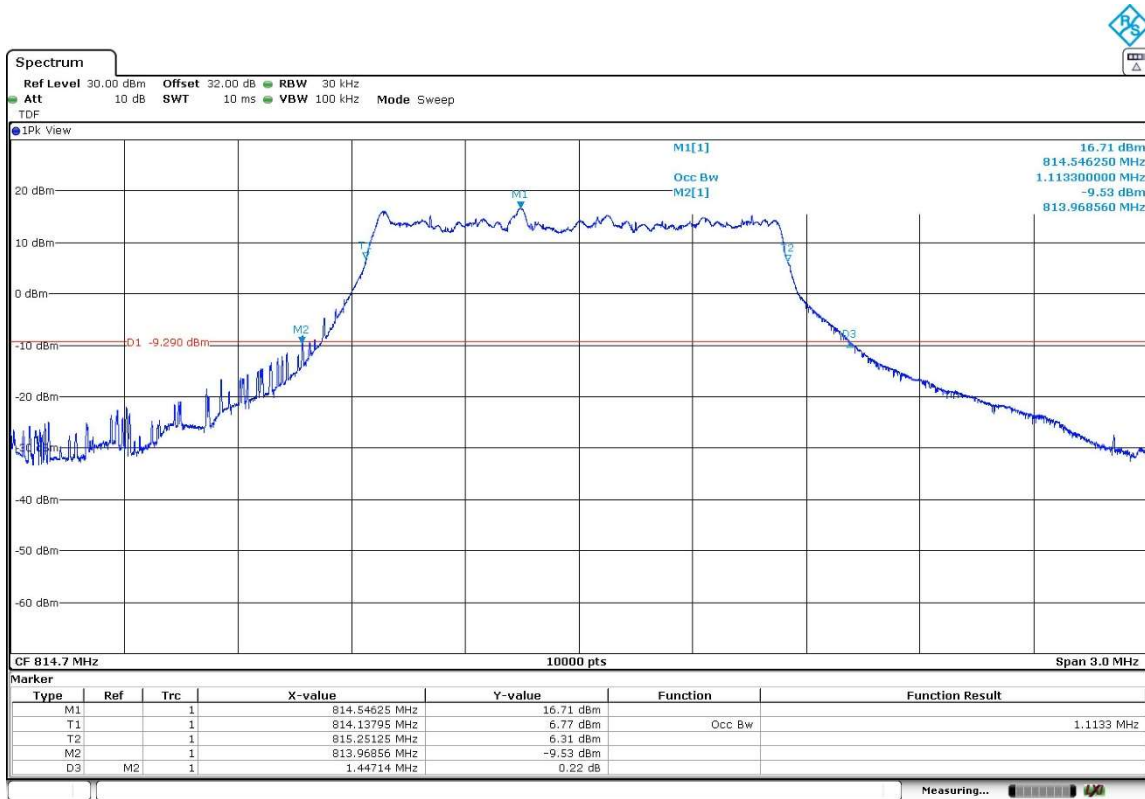

High Channel:

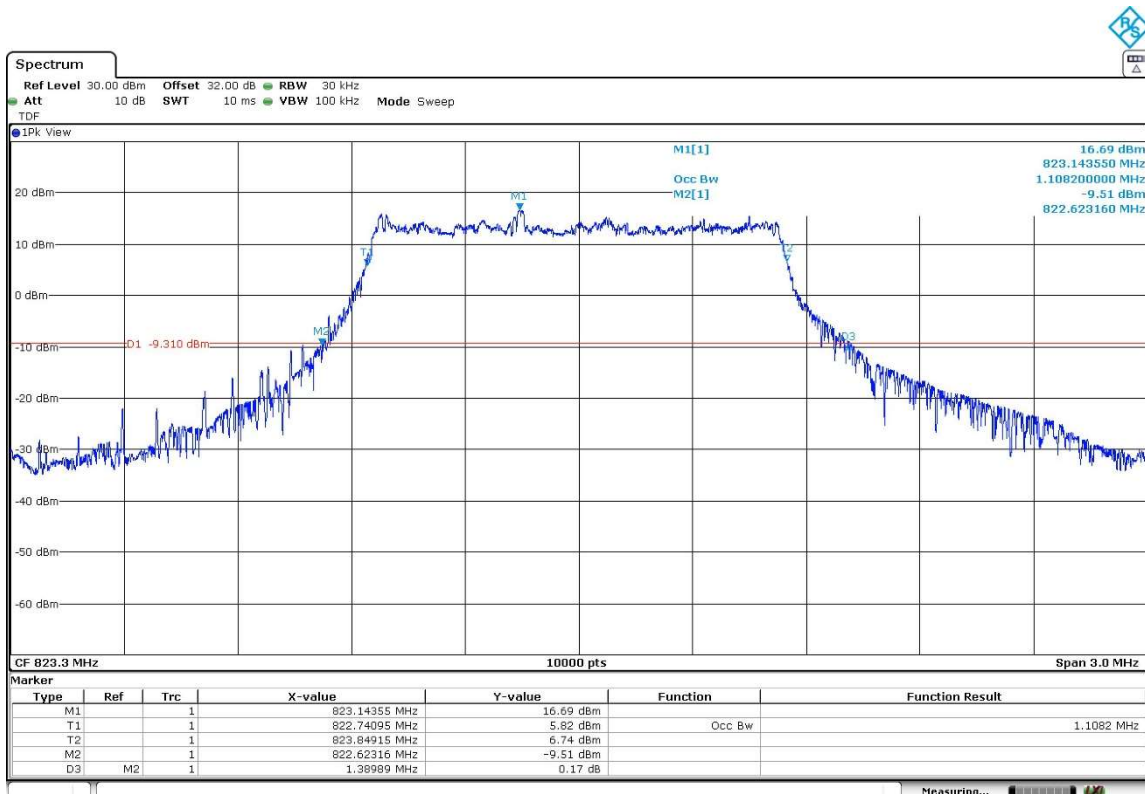

LTE Cat-M1 Band 26. Sub-band 814-824 MHz. BW = 1.4 MHz. 16QAM.

Low Channel:

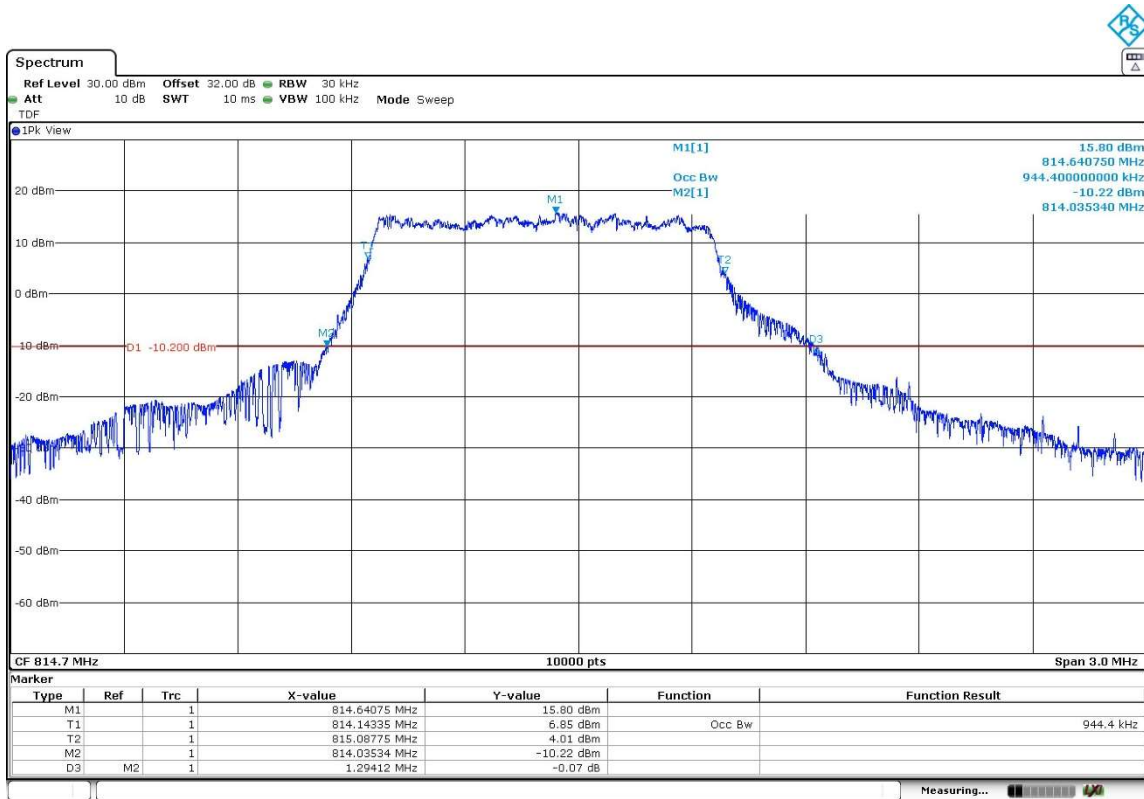

High Channel:

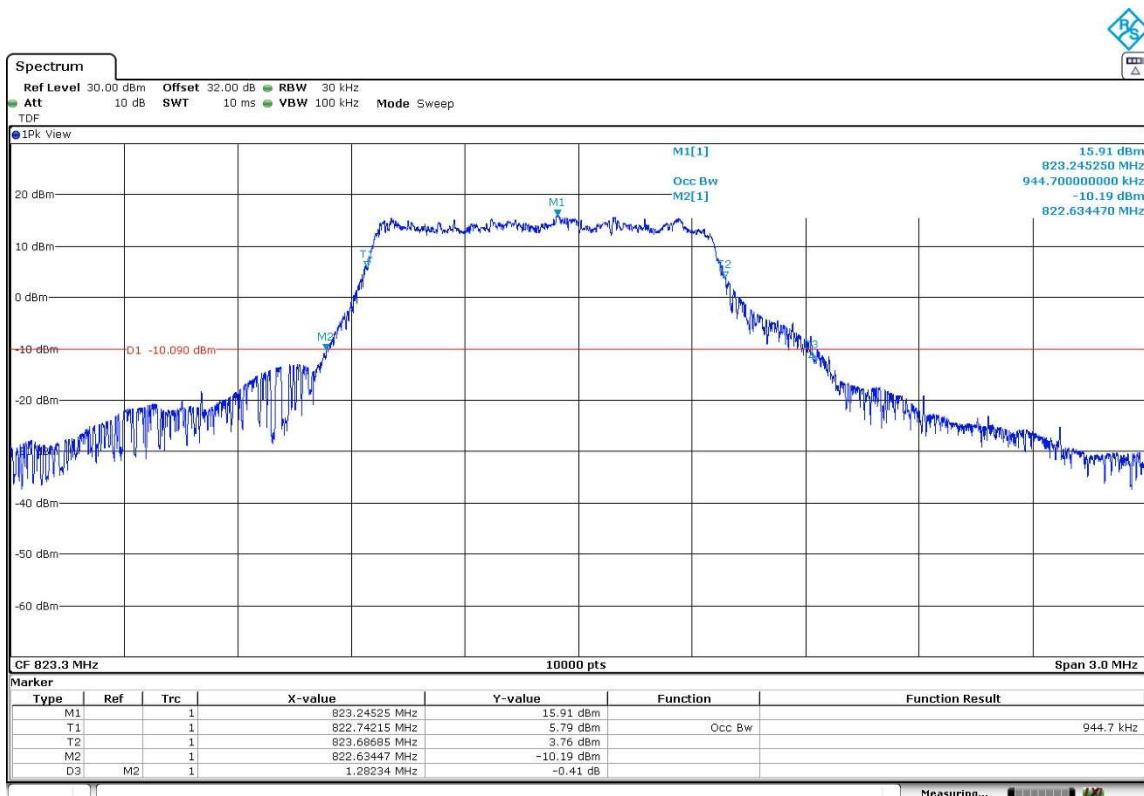

LTE Cat-M1 Band 26. Cross-rule Channel 824 MHz. BW = 1.4 MHz. QPSK.

Cross-rule Channel 824 MHz:

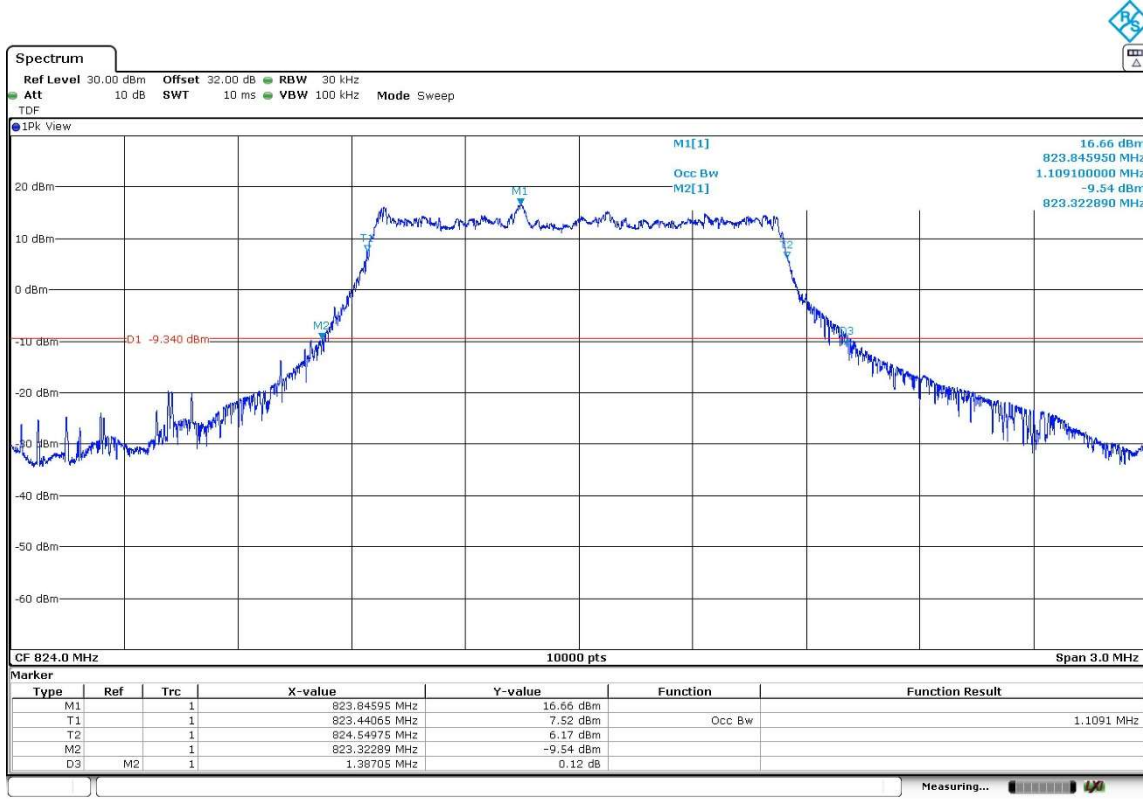

LTE Cat-M1 Band 26. Cross-rule Channel 824 MHz. BW = 1.4 MHz. 16QAM.

Cross-rule Channel 824 MHz:

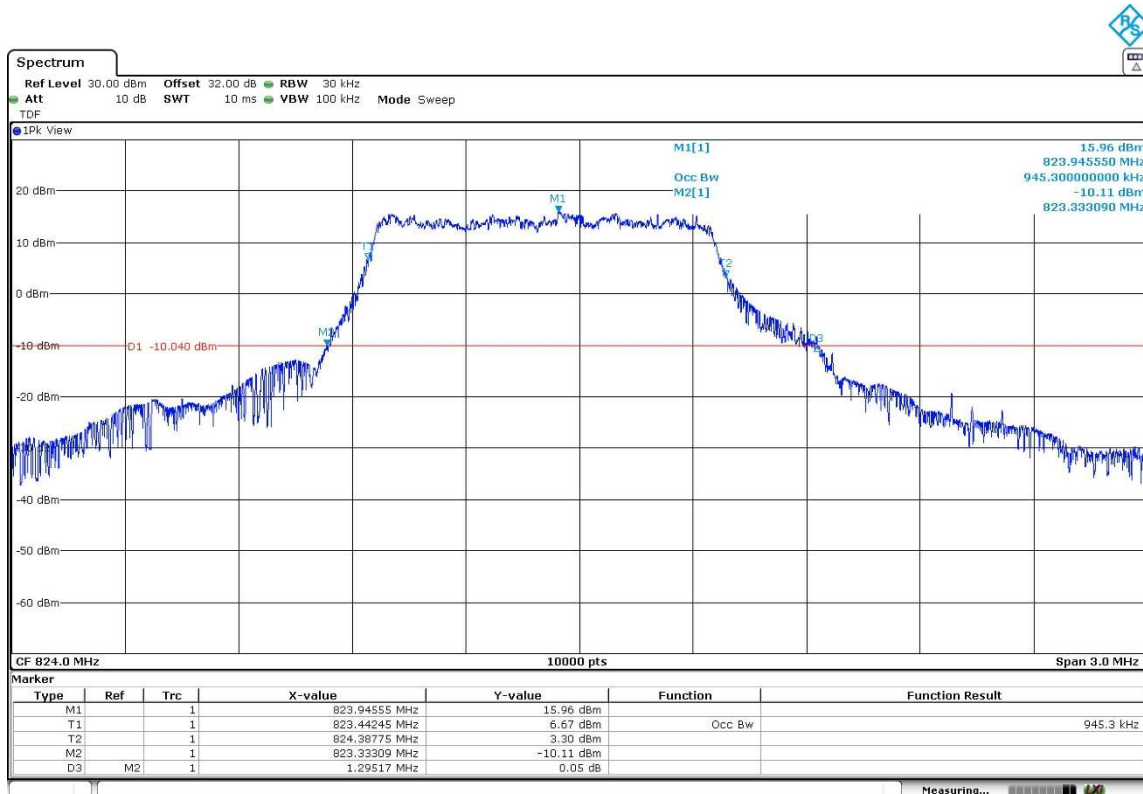

Spurious emissions at antenna terminals

Limits

FCC §2.1051. Measurements required: Spurious emissions at antenna terminals.

FCC §90.543 (e) (2) (3) & (5):

(e) For operations in the 758-768 MHz and the 788-798 MHz bands, the power of any emission outside the licensee's frequency band(s) of operation shall be attenuated below the transmitter power (P) within the licensed band(s) of operation, measured in watts, in accordance with the following:

(2) On all frequencies between 769-775 MHz and 799-805 MHz, by a factor not less than $65 + 10 \log (P)$ dB in a 6.25 kHz band segment, for mobile and portable stations.

(3) On any frequency between 775-788 MHz, above 805 MHz, and below 758 MHz, by at least $43 + 10 \log (P)$ dB.

(5) Compliance with the provisions of paragraph (e)(3) of this section is based on the use of measurement instrumentation employing a resolution bandwidth of 100 kHz or greater. However, in the 100 kHz bands immediately outside and adjacent to the frequency block, a resolution bandwidth of 30 kHz may be employed.

FCC §90.691:

(a) Out-of-band emission requirement shall apply only to the "outer" channels included in an EA license and to spectrum adjacent to interior channels used by incumbent licensees. The emission limits are as follows:

(1) For any frequency removed from the EA licensee's frequency block by up to and including 37.5 kHz, the power of any emission shall be attenuated below the transmitter power (P) in watts by at least $116 \log_{10}(f/6.1)$ decibels or $50 + 10 \log_{10}(P)$ decibels or 80 decibels, whichever is the lesser attenuation, where f is the frequency removed from the center of the outer channel in the block in kilohertz and where f is greater than 12.5 kHz.

(2) For any frequency removed from the EA licensee's frequency block greater than 37.5 kHz, the power of any emission shall be attenuated below the transmitter power (P) in watts by at least $43 + 10 \log_{10}(P)$ decibels or 80 decibels, whichever is the lesser attenuation, where f is the frequency removed from the center of the outer channel in the block in kilohertz and where f is greater than 37.5 kHz.

(b) When an emission outside of the authorized bandwidth causes harmful interference, the Commission may, at its discretion, require greater attenuation than specified in this section.

Method

The EUT RF output connector was connected to a spectrum analyser and to the Universal Radio Communication tester R&S CMW500 (selecting maximum transmission power of the EUT and different modes of modulation) using a 50 Ohm attenuator and a power divider.

The spectrum was investigated from 9 kHz to 18 GHz for 3G Band IV and from 9 kHz to 8 GHz for LTE Band 13. The reading of the spectrum analyser is corrected with the attenuation loss of connection between output terminal of EUT and input of the spectrum analyser.

The configuration of Resource Blocks and modulation which is the worst case for conducted power was used.