

CUSTOMER: _____

日期 DATE: _____

纳入仕様书 SPECIFICATION

产品名称 PRODUCT NAME: 陶瓷天线

Ceramic antenna

贵司料号 YOUR PART NO.:

敝司料号 OUR PART NO.: MGMA3216H2450-A02

版本号 VERSION NO.: V1.0

接受 RECEPTION

THE SPECIFICATION HAS BEEN ACCEPTED.

该纳入仕様书已被我司接受

日期:
DATE:

公司:
COMPANY:

批准

CFMD

审核

CHKD

接收

RCVD

本纳入仕様书共 13 页

MANUFACTURING NAME

深圳市麦捷微电子科技股份有限公司

SHENZHEN MICROGATE TECHNOLOGY CO., LTD

TEL: 86-755-28085000

FAX: 86-755-28085605

CFMD. 批准	CHKD. 审核	DSGD. 担当
梁启新	赖定权	曾艳锋

深圳市麦捷微电子科技股份有限公司

地址: 深圳市坪山区龙田街道竹坑社区坪山科技路麦捷科技智慧园

电话(Tel): 0755-28085000

传真(Fax): 0755-28085605

邮编(Postcode): 518118

纳入仕様书改定履历 MODIFY HISTORY OF SPECIFICATION

NO.	DATE	CONTENT	REV	APPROVED
1	2006-10-25	初稿 Constitute	1.0	张海恩

深圳市麦捷微电子科技股份有限公司

地址：深圳市坪山区龙田街道竹坑社区坪山科技路麦捷科技智慧园

电话(Tel): 0755-28085000

传真(Fax): 0755-28085605

邮编(Postcode): 518118

目录 CATALOG

1 适用范围 Scope.....	4
2 品名构成 Product Identification.....	4
3 形状、尺寸 Appearance and Dimensions.....	4
4 测试电路及测试条件 Testing Conditions.....	4
5 电气性能 Electrical Characteristics.....	5
6 特性曲线 Characteristic curve.....	6
7 信赖性试验 Reliable Performance.....	7
8 焊接条件 Recommended Soldering Conditions.....	9
9 包装 Packaging.....	10
10 装箱清单及标志 Packing documents and marking.....	11
11 保管 Storage.....	13

1 适用范围 Scope

陶瓷天线系列产品，设计用于 WLAN、HomeRF、Bluetooth、Module 等，小体积 SMD 片式设计。

ceramic antenna series are designed to be used in WLAN、HomeRF、Bluetooth、Module、etc, small size SMD chip design.

2 品名构成 Product Identification

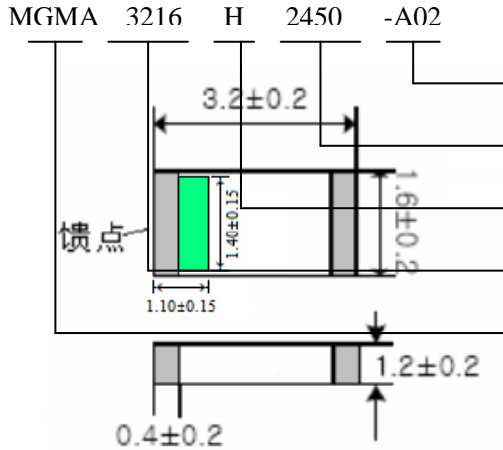

标准规格，编号：A02/Normaling Type: A02

中心频率/ Center Frequency: 2450MHz

结构：过孔设计

产品尺寸：3.2×1.6×1.2 S 型 (mm)

陶瓷天线/Ceramic antenna

All the technical data and information specified herein are subject to variation without prior notice Unit: mm

3

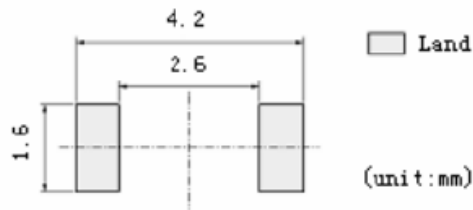
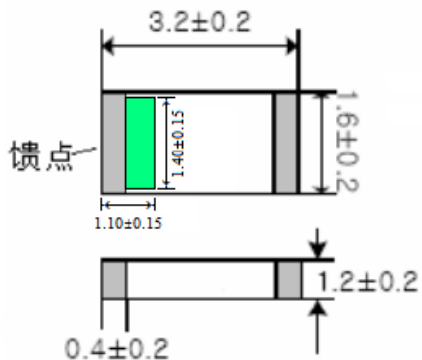

All the technical data and information specified herein are subject to variation without prior notice

4 测试电路及测试条件 Test Circuit and Testing Conditions

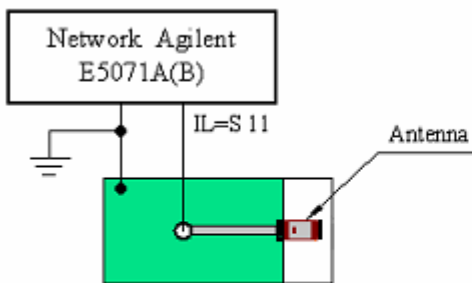

无匹配电路测试-3.5GHz中心频率
No Matching Circuit Testing

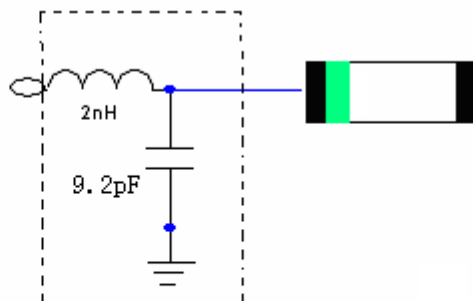

LC 匹配电路
LC Matching Circuit Testing

深圳市麦捷微电子科技股份有限公司

地址：深圳市坪山区龙田街道竹坑社区坪山科技路麦捷科技智慧园

电话(Tel): 0755-28085000

传真(Fax): 0755-28085605

邮编(Postcode): 518118

4

除非另有规定，否则在以下条件下测试 <Unless otherwise specified>

温度 Temperature : Ordinary Temperature (5 to 35°C)
湿度 Humidity : Ordinary Humidity (25 to 85% RH)

大气压强 Atmospheric Pressure : 86 to 106 kPa

当对测量结果有疑问时<In case of doubt>

温度 Temperature : 20±2°C
湿度 Humidity : 55 to 75% RH
大气压强 Atmospheric Pressure : 86 to 106 kPa

5 电气性能 Electrical Characteristics

操作温度范围 Operating Temperature Range : -40 to +85°C

保存温度范围 Storage Temperature Range : -40 to +85°C

No.	Item (项目)	Specifications (特性)
1	Frequency 频率 (No matching)	2400-2500MHz
	(带匹配电路测试)After Matching	2450 MHz
2	Band Width 通带宽度(No matching)	200 MHz (3400~3600MHz)
	(带匹配电路测试)After Matching	100 MHz (2400~2500MHz)
3	Gain 增益	-5.08 dBi
4	V. S. W. R (in BW) 驻波比	≤2.0
5	Polarization 极化方式	Linear 线性
6	Azimuth Beam width 方位角	Omni-directional 全向
7	Impedance 阻抗	50 Ω

深圳市麦捷微电子科技股份有限公司

地址：深圳市坪山区龙田街道竹坑社区坪山科技路麦捷科技智慧园

电话(Tel): 0755-28085000

传真(Fax): 0755-28085605

邮编(Postcode): 518118

5

Freq (MHz)	Effi (%)	Gain (dBi)
2400	22%	-6.507324
2410	24%	-6.180729
2420	25%	-6.021038
2430	26%	-5.822719
2440	27%	-5.744008
2450	28%	-5.563936
2460	28%	-5.535502
2470	29%	-5.325254
2480	30%	-5.227285
2490	31%	-5.088349
2500	31%	-5.084538

2400MHz

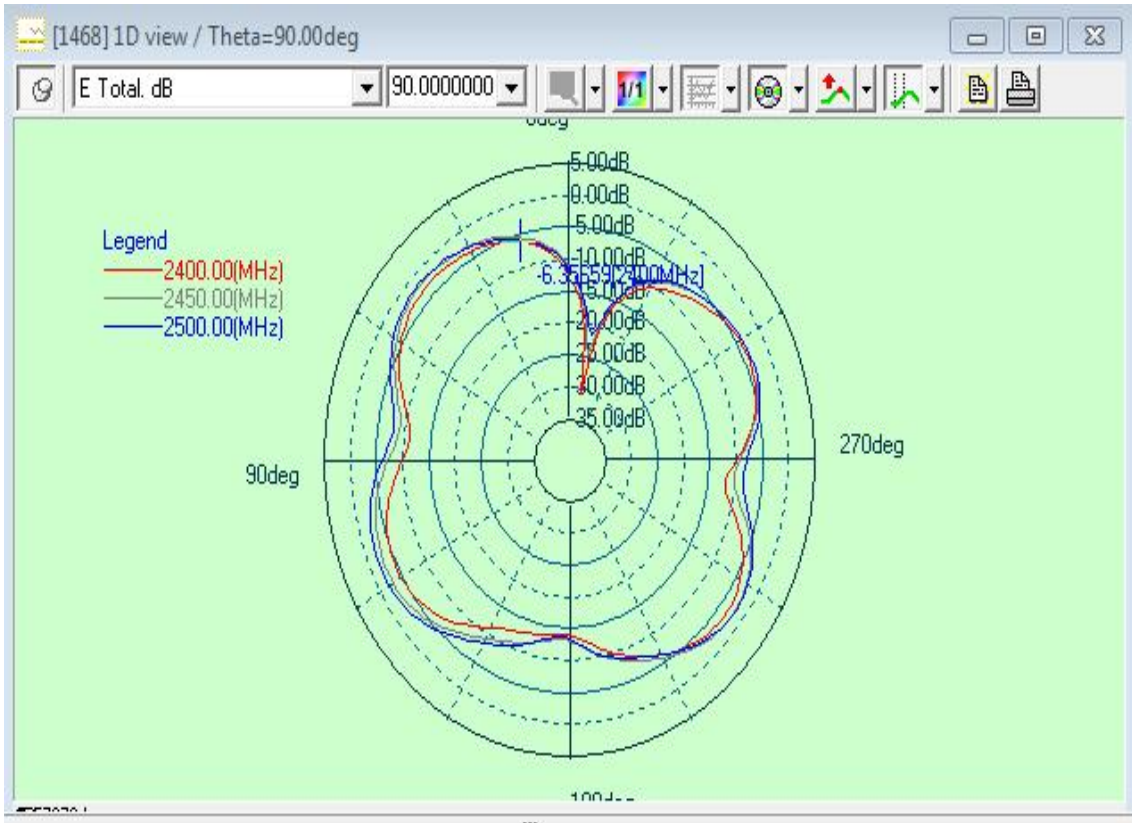

2450MHz

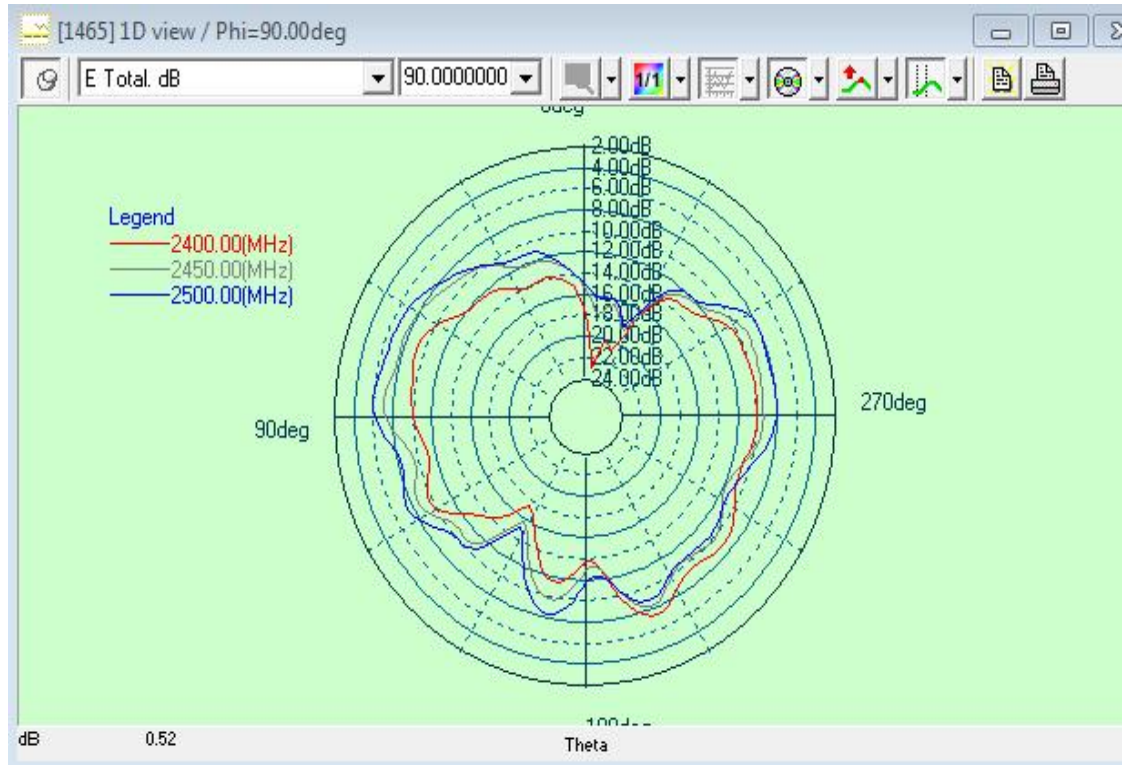

2500MHz

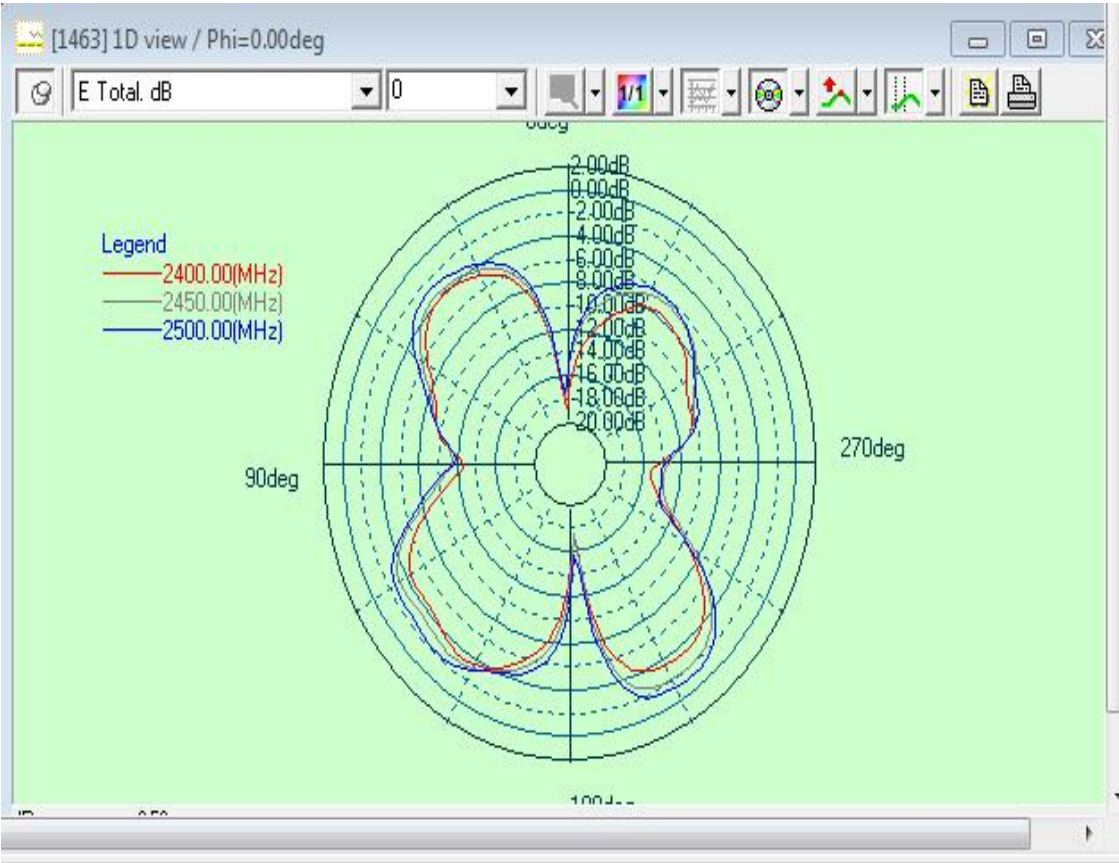

6 特性曲线 Characteristic curve

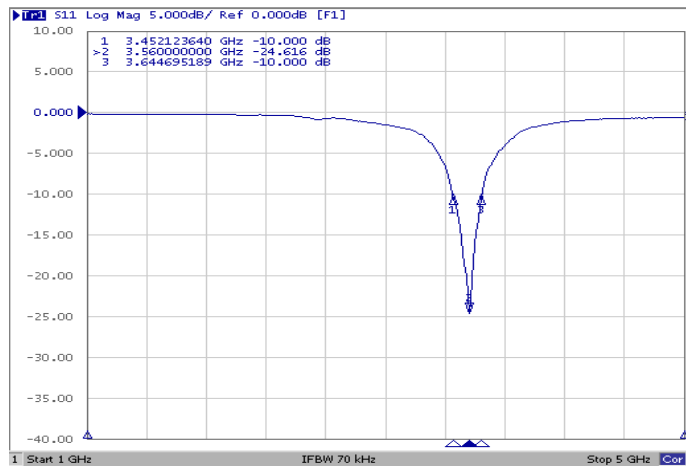

1) Before Matching



2) After Matching

深圳市麦捷微电子科技股份有限公司

地址：深圳市坪山区龙田街道竹坑社区坪山科技路麦捷科技智慧园

电话(Tel): 0755-28085000

传真(Fax): 0755-28085605

邮编(Postcode): 518118

7 可靠性试验 Reliable Performance

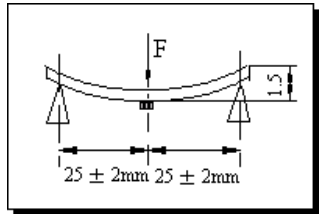
NO.	Item	Specifications	Test Methods	
7-1	Solder-Ability 可焊性	More than 90% of termination should be covered with new solder. 端电极焊锡覆盖率为90%以上。	焊锡 Solder: Sn: Pb=	100:0
			焊锡温度 Temperature:	255°C+5°C/-0°C
			助焊剂 Flux: 松香 rosin	
			浸渍时间 Duration:	5±0.5s
7-2	Leaching Resistance 耐焊性	More than 75% of termination Should be covered with new solder. 端电极焊锡覆盖率为75%以上	焊锡 Solder: Sn: Pb=	100:0
			焊锡温度 Temperature:	270°C+2°C/-0°C
			助焊剂 Flux: 松香 rosin	
			浸渍时间 Duration:	10±0.5s
7-3	Terminal Strength 端头强度	The terminal and body should be no damage 端头和瓷体不应见损伤	<p>The device should not be broken after tensile force of 1.0kg is slowly applied to pull a lead pin of the fixed device in the lead axis direction for 10±1 seconds.</p> <p>在产品电极端子上或表面上应能承受 1kg 垂直拉力 10±1 秒</p>	
7-4	Bending Strength 弯曲试验	No mechanical damage should be noticed 不应见机械损伤	<p>Weld the product to the center part of the PCB with the thickness 1.6±0.2mm as the illustration shows, and keep exerting force arrow-ward on it at speed of: 1mm/S, and hold for 5±1S at the position of 1.5mm bending distance, so far, any peeling off of the product metal coating should not be detected.</p> <p>将产品按图焊在 1.6±0.2mm 的 PCB 板中间, 由箭头方向施力 1mm/S, 弯曲距离 1.5mm, 保持 5±1S, 产品金属层无脱落。</p> 	

NO.	Item	Specifications	Test Methods	
7-5	Drop 跌落	Post Environmental Tolerance (环境试验后允许附加误差)	Drop 10 times on a concrete floor from a height of 1m. 从距混凝土地面 1m 高度自由落下, 重复 3 次。	
7-6	Vibration 振动		频率 Frequency: 10 to 55Hz 振幅 Amplitude: 1.5mm 方向及时间 Direction and time: X, Y and Z directions for 2 hours each.	
7-7	Humidity resistance 耐潮湿		a. 试验条件 Test condition 温度 Temp.: 60±2°C 湿度 Humidity: 90%~95% 试验时间 Test time: 96±2 h b. 测量条件 Measurement method: 试验后常温常湿环境中放置 (24±2) 小时后测量。 The component should be stabilized at normal condition for (24±2) hours before test.	
7-8	High temperature resistance 耐高温		1 Center Frequency 中心频率: ±25 MHz; 2 Band Width 通带宽度: ±20 MHz; 3 Gain 增益: ±0.2 dBi 4 V.S.W.R (in BW) 驻波比: ±0.5 dB;	a. 试验条件 Test condition 温度 Temp.: + 85±2°C 试验时间 Test time: 96±2 h b. 测量条件 Measurement method: 试验后常温常湿环境中放置 (24±2) 小时后测量。 The component should be stabilized at normal condition for (24±2) hours before test.
7-9	Low temperature resistance 耐低温			a. 试验条件 Test condition 温度 Temp.: -40±2°C 试验时间 Test time: 96±2 h b. 测量条件 Measurement method: 试验后常温常湿环境中放置 (24±2) 小时后测量。 The component should be stabilized at normal condition for (24±2) hours before test.
7-10	Thermal shock (Temperature cycle) 热冲击 (温度循环)			a. 试验条件 Test condition 1) 温度 Temp.: -40°C, 时间 time: 30±3min 2) 温度 Temp.: +85°C, 时间 time: 30±3min 5 cycles b. 测量条件 Measurement method: 试验后常温常湿环境中放置 (24±2) 小时后测量。 The component should be stabilized at normal condition for (24±2) hours before test.

深圳市麦捷微电子科技股份有限公司

地址: 深圳市坪山区龙田街道竹坑社区坪山科技路麦捷科技智慧园

电话(Tel): 0755-28085000

传真(Fax): 0755-28085605

邮编(Postcode): 518118

8

8 焊接条件 Recommended Soldering Conditions

1、焊剂 Flux, Solder

① 使用松香助焊剂，禁止使用卤化物含量超过 0.2wt% 的强酸性助焊剂。

Use rosin-based flux. Don't use highly acidic flux with halide content exceeding 0.2wt% (chlorine conversion value).

② 使用纯锡焊料 Use Sn solder.

2、回流焊条件 Reflow soldering conditions

● 预热时，产品表温与焊料温度的温差最大不允许超出 150℃，焊接完后冷却时，产品表温与溶剂温度之间的温差最大不允许超出 100℃。预热不足有可能引发产品表面裂纹，导致产品品质下降。

Pre-heating should be in such a way that the temperature difference between solder and product surface is limited to 150℃ max. Cooling into solvent after soldering also should be in such a way that temperature difference is limited to 100℃ max. Unwrought pre-heating may cause cracks on the product, resulting in the deterioration of products quality.

● 标准回流焊曲线 Standard soldering profile.

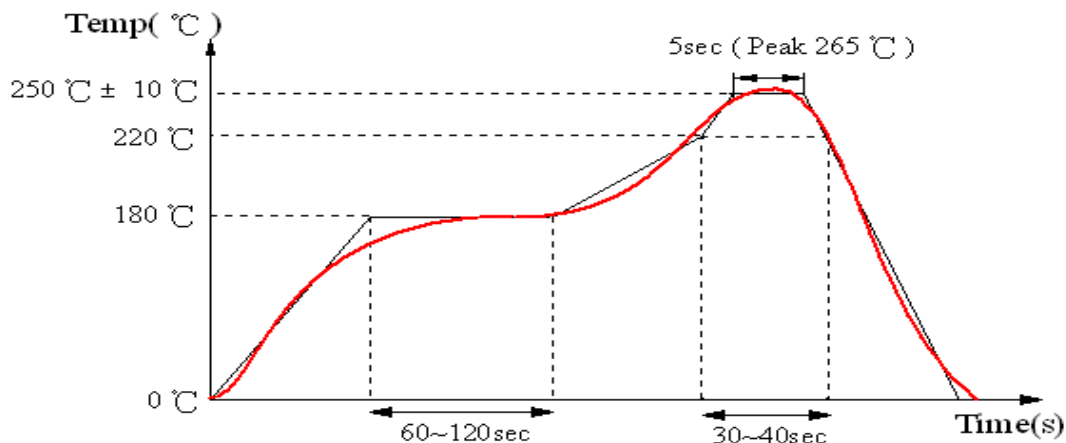

3、手工返工 Reworking with soldering iron

当使用电烙铁进行手工焊接时，以下条件必须严格遵守 The following conditions must be strictly followed when using a soldering iron.

预热 Pre-heating	150℃, 1 minute
尖端温度 Tip temperature	350℃ max
输出功率 Soldering iron output	80w max
电烙铁头尖端尺寸 End of soldering iron	φ3mm max
焊接时间 Soldering time	3 seconds max

深圳市麦捷微电子科技股份有限公司

地址：深圳市坪山区龙田街道竹坑社区坪山科技路麦捷科技智慧园

电话(Tel): 0755-28085000

传真(Fax): 0755-28085605

邮编(Postcode): 518118

9 包装 Packaging

① 编带尺寸 Dimensions of Tape:

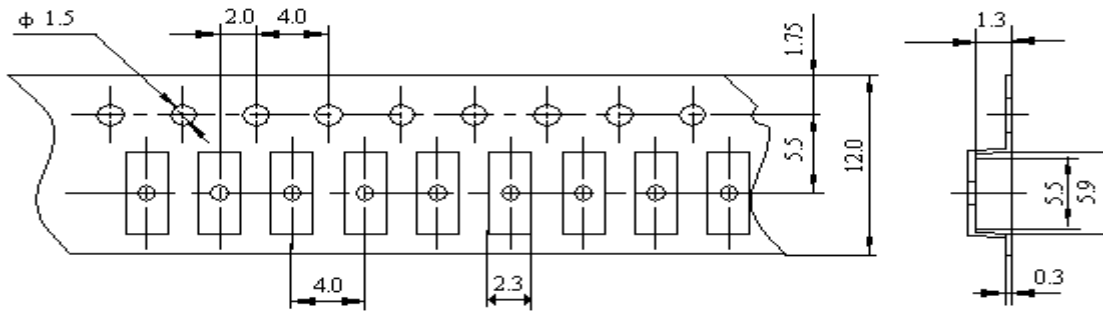

② 带轮尺寸 Dimensions of Reel

Unit: mm

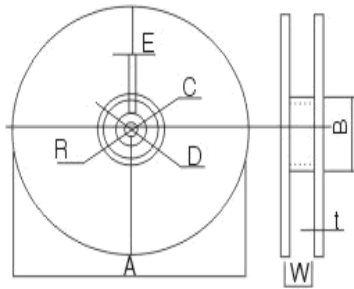

Reel material: PS (Polystyrene)

A	178±2
B	60±2
C	13.0±0.5
D	21.0±0.8
E	2.0±0.5
W	12.5±1.5
t	1.2±0.2
R	1.0±0.25

③ 编带抗拉强度 Pulling strength of tapes:

载带 Carrier tape	10N or more (1kgf or more)
上盖带 Cover tape	5N or more (1kgf or more)

④ 编带简图及拉伸方向 Taping figure and drawing direction:

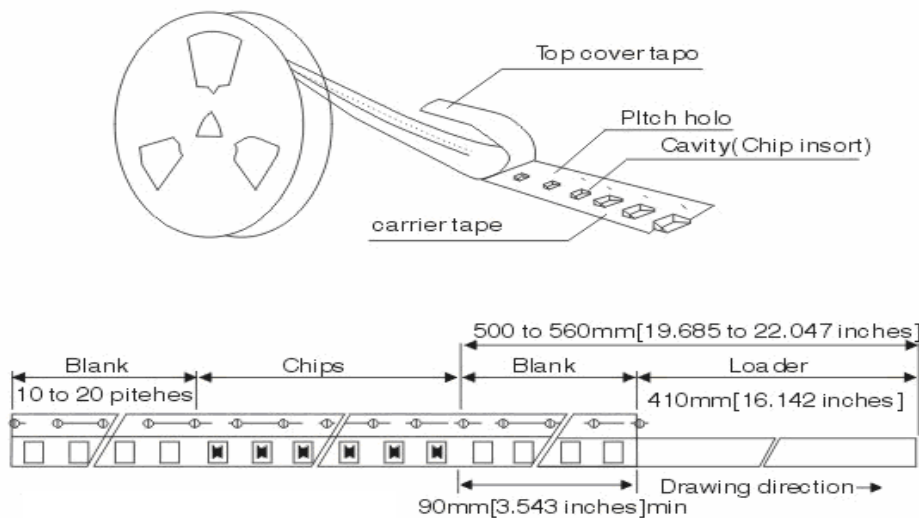

深圳市麦捷微电子科技股份有限公司

地址: 深圳市坪山区龙田街道竹坑社区坪山科技路麦捷科技智慧园

电话(Tel): 0755-28085000

传真(Fax): 0755-28085605

邮编(Postcode): 518118

⑤ 盖带的剥离强度 Peeling strength of cover tape:

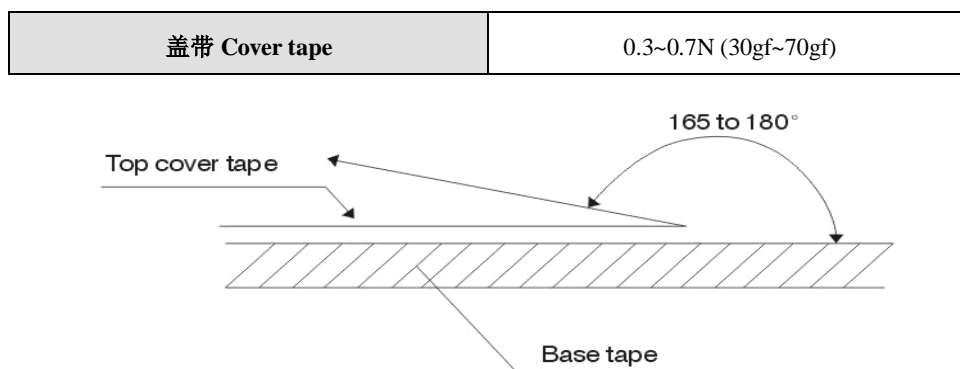

测试条件 Test condition:

- 1) 剥离角度 peel angle: 165°~180° vs. carrier tape.
- 2) 剥离速度 peel speed: 300mm/min±10%.

⑥ 包装数量 Packaging quantities: 3000 PCS / Reel

10 装箱清单及标志 Packing documents and marking

1. 包装文件 Packing documents

Packing includes the following:

- a. 装箱清单 Packing list.
- b. 合格证书 Certificate of compliance.

2. 盘上标记 Marking on reels:

- a 麦捷料号 MICROGATE Part No.
- b 生产批号 Lot number
- c 盘装数量 Quantity per reel
- d 检验员号 Inspector No.

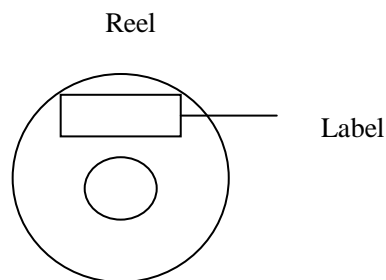

以上内容必须在标签上注明.All above shall be shown on marking label

麦捷公司标签如下所示: MICROGATE marking label will be as following:

MICROGATE		
CUSTOMER:	P. O. NO	
CUSTOMER PART NO:	DATE CODE	LOT NO
MG PART NO:	QUANTITY	INSP. NO



深圳市麦捷 **MG PART NO** 有限公司

地址: 深圳市坪山区龙田街道竹坑社区坪山科技路麦捷科技智慧园

电话(Tel): 0755-28085000

传真(Fax): 0755-28085605

邮编(Postcode): 518118

检验合格后,检验员在标签上盖上合格章。合格章如下所示: The eligible reels will be pressed a mark onto the surface. The mark will be as following:

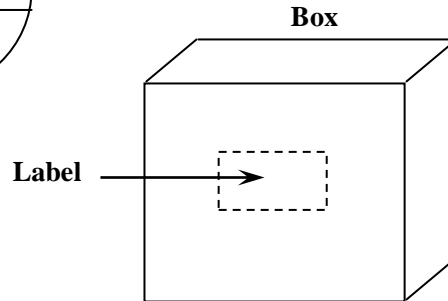
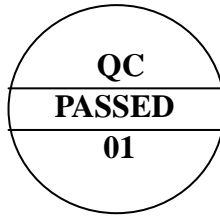

3. 内包装盒标记:Marking on inner box

- a. 型号 MICROGATE part No.
- b. 每盒数量 Quantity per box
- c. 包装日期 Date

以上内容必须在标签上注明(标签见 11.2 所示)。Above shall be shown on marking label (The marking label is shown in item 9.2).

4. 外包装箱标记 Marking on outer case:

- 1) 制造商 Manufacturer: “MICROGATE” ①

“中国深圳制造” “Made in Shenzhen CHINA”②

- 2) 发运标记 Ship marking:

“向上” “UP”, “小心轻放”“HAND CARE”, “防潮”“MOISTURE-PROOF”.

- 3) 包装标签包括以下内容 Packing label include the following:

- a. 型号 MICROGATE Part No
- b. 总数量 Total quantity per case
- c. 包装日期 Date;

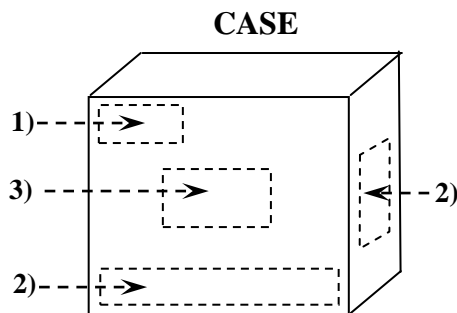

以上内容必须在标签上注明。(参见 11.2 所示)

All above shall be shown on marking label.

(The marking label is shown in item 11.2)

11 保管 Storage

①. 保管期限 Storage period

距麦捷出厂检验时间六个月内，产品可以使用；检验时间可以通过包装外侧标记的检验号确认；若时间超出六个月，应检查焊接性能后方可使用。Products which inspected in MICROGATE over 6 months ago should be examined and used, which can be confirmed with inspection No. marked on the container. Solder ability should be checked if this period is exceeded.

②. 保存条件 Storage conditions

●存放货物的库房应满足以下条件 Products should be storage in the warehouse on the following conditions

温度 Temperature: $\leq 40^{\circ}\text{C}$

湿度 Humidity : $\leq 70\%$ relative humidity

不允许温、湿度有极剧变化。No rapid change on temperature and humidity

●禁止将产品保管在腐蚀性物质中，例如硫磺、氯气或者酸，否则将引起端头氧化，导致降低焊接性。Don't keep products in corrosive gases such as sulfur, chlorine gas or acid, or it may cause oxidization of electrode, resulting in poor solder ability.

●为了避免受潮气、灰尘等物质的影响，产品应保管于货架上。Products should be storage on the palette for the prevention of the influence from humidity, dust and so on.

●产品保管在库房中时，应避免热冲击，振动以及直接光照等等。Products should be storage in the warehouse without heat shock, vibration, and direct sunlight and so on.

●产品应密封包装 Products should be storage under the airtight packaged condition.