

Annex B. EUT And Test Setup Photographs

Annex B.i. Photograph: EUT External Photo

EUT - Front View



EUT - Rear View



EUT - Top View



EUT - Bottom View



EUT - Left View



EUT - Right View



Annex B.ii. Photograph: EUT Internal Photo

Cover Off - Top View 1



Cover Off - Top View 2



Battery - Front View

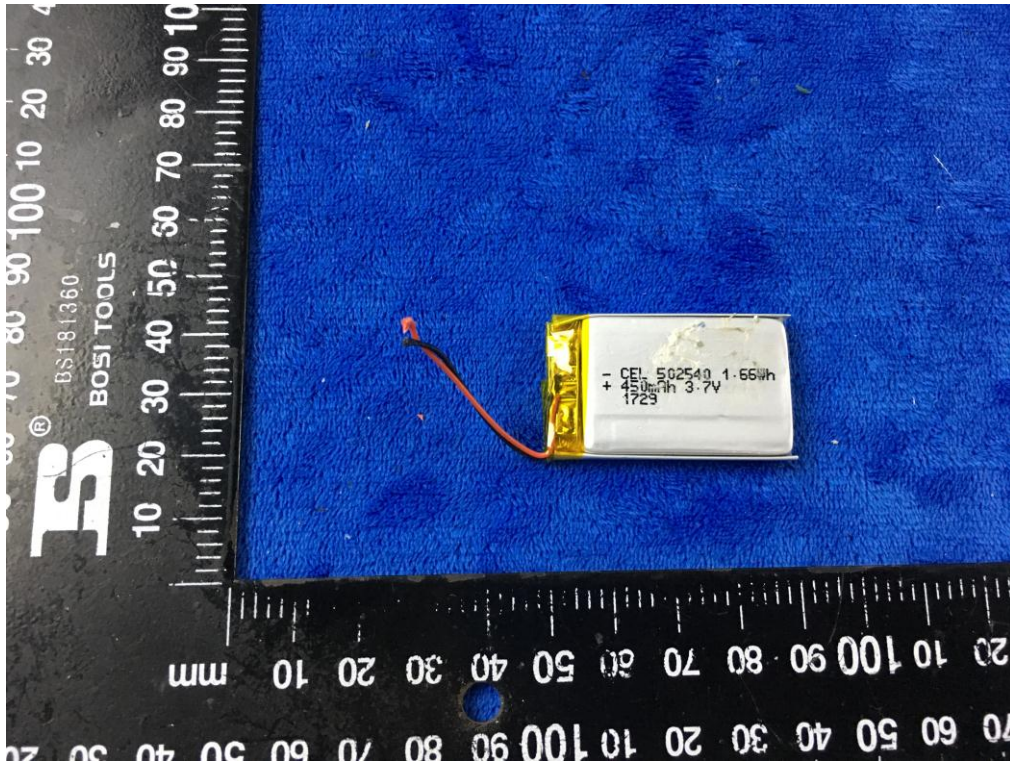

Battery - Rear View

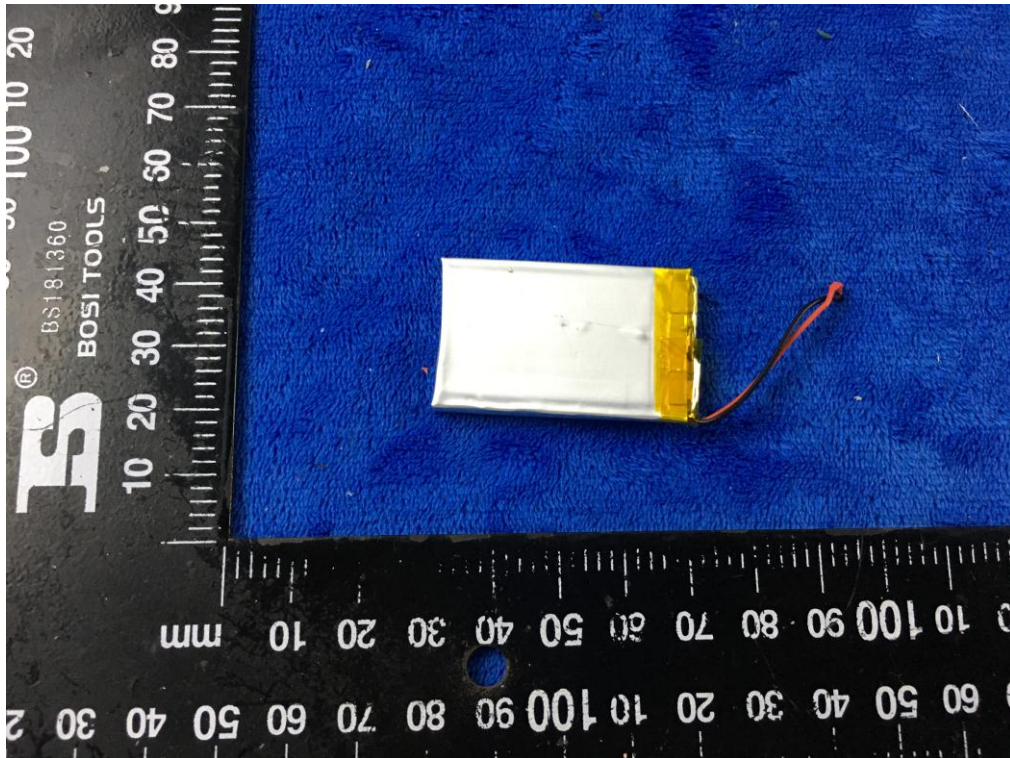

Mainboard - Front View

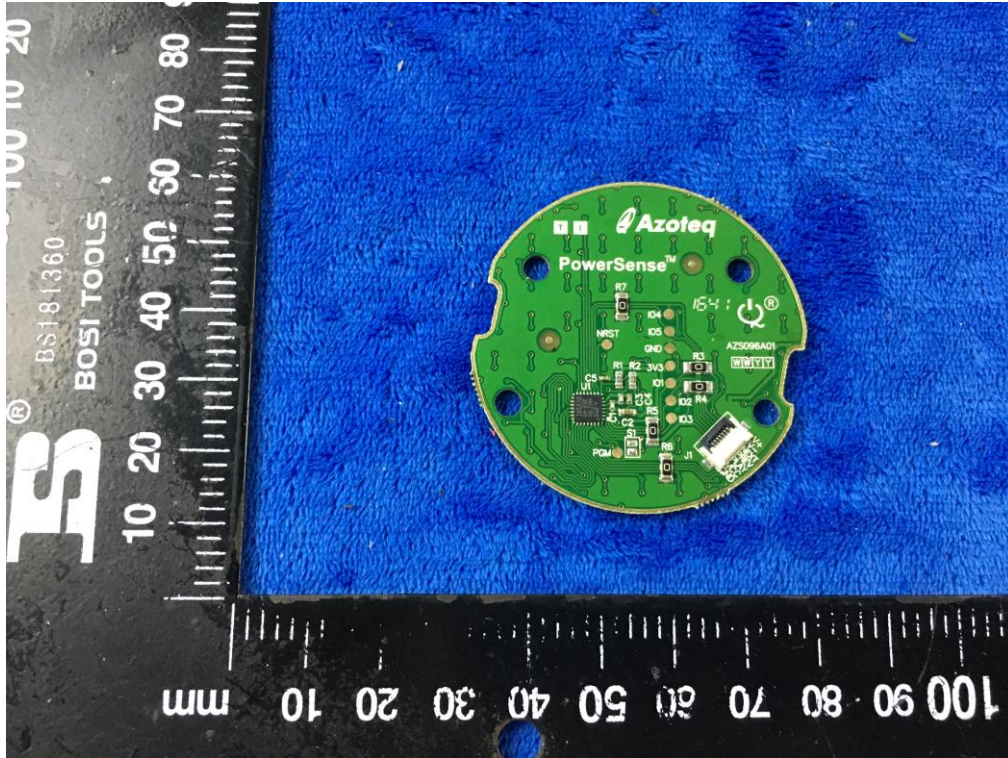

Mainboard - Rear View

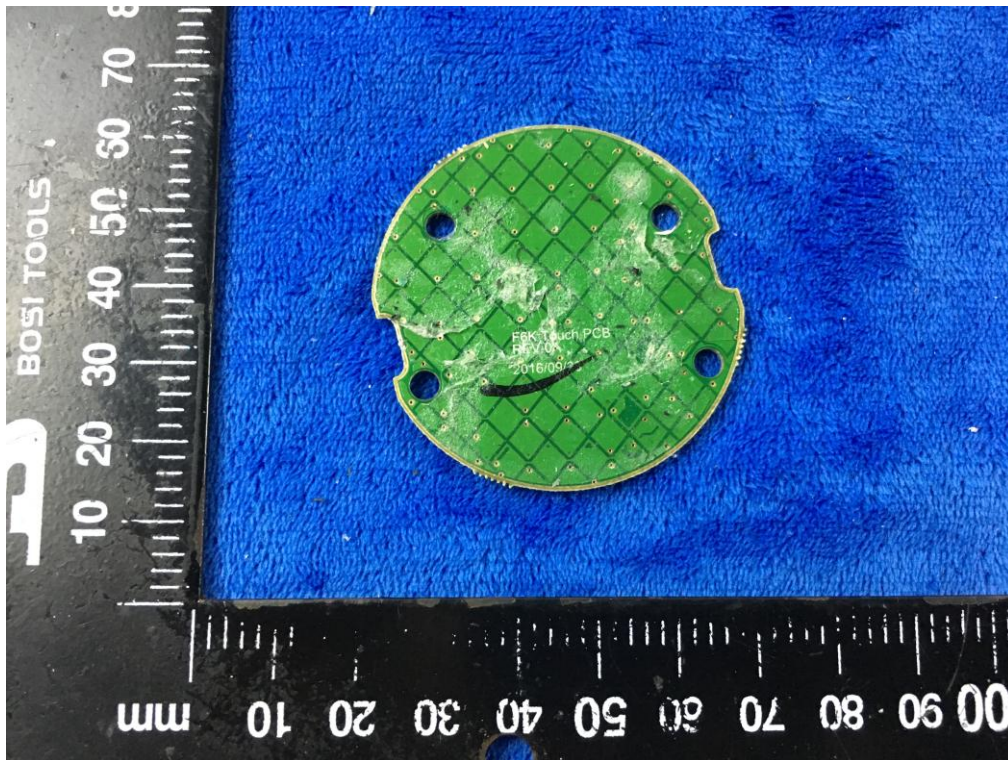

USB board - Front View

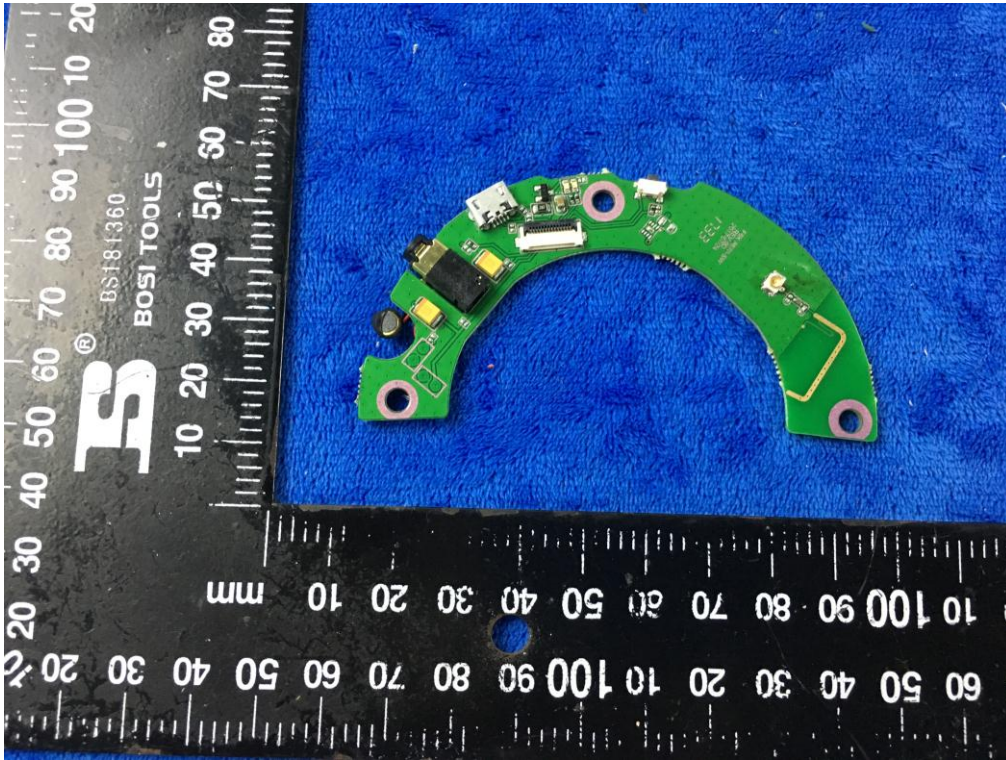

USB board- Rear View

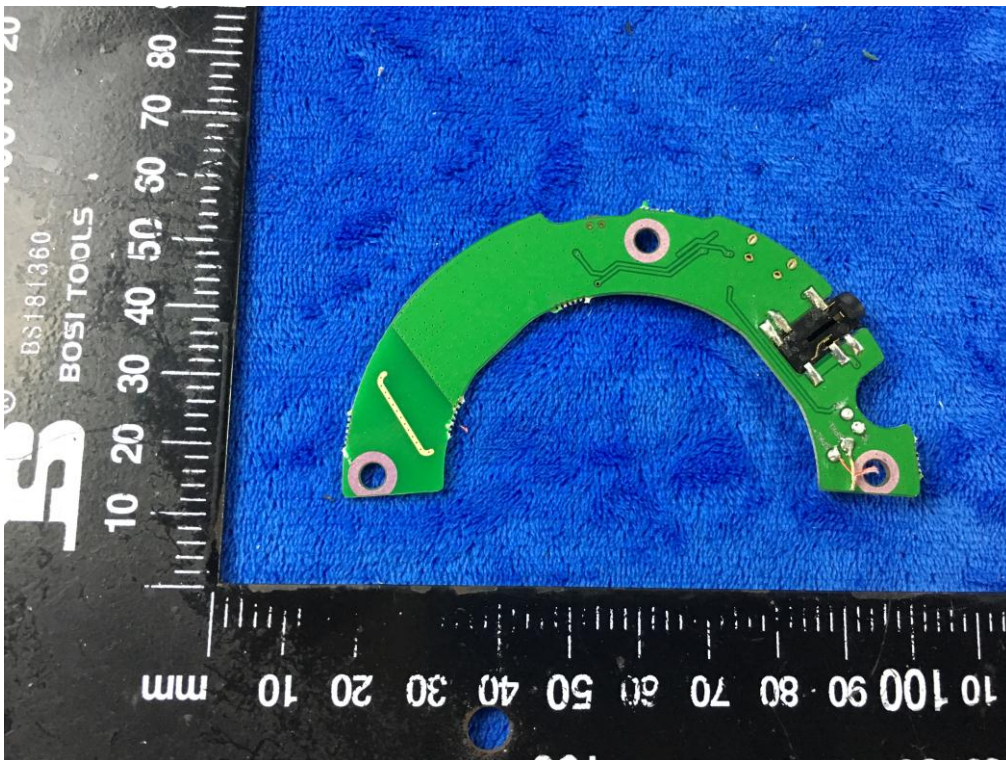

Smallboard - Front View

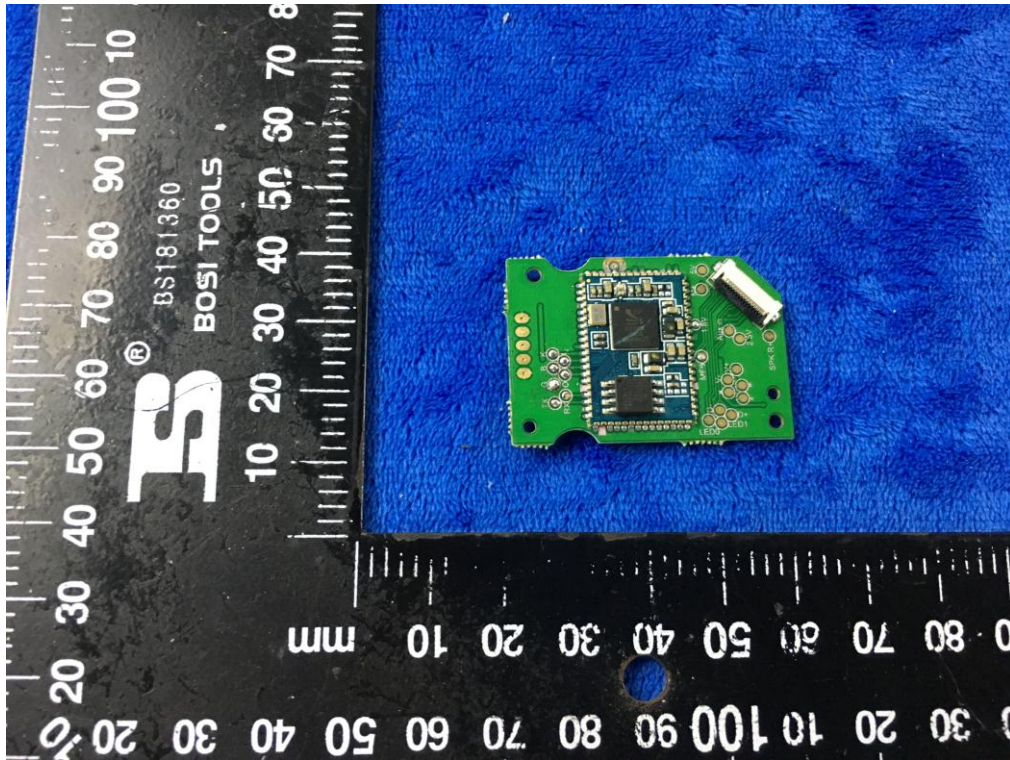

Smallboard- Rear View

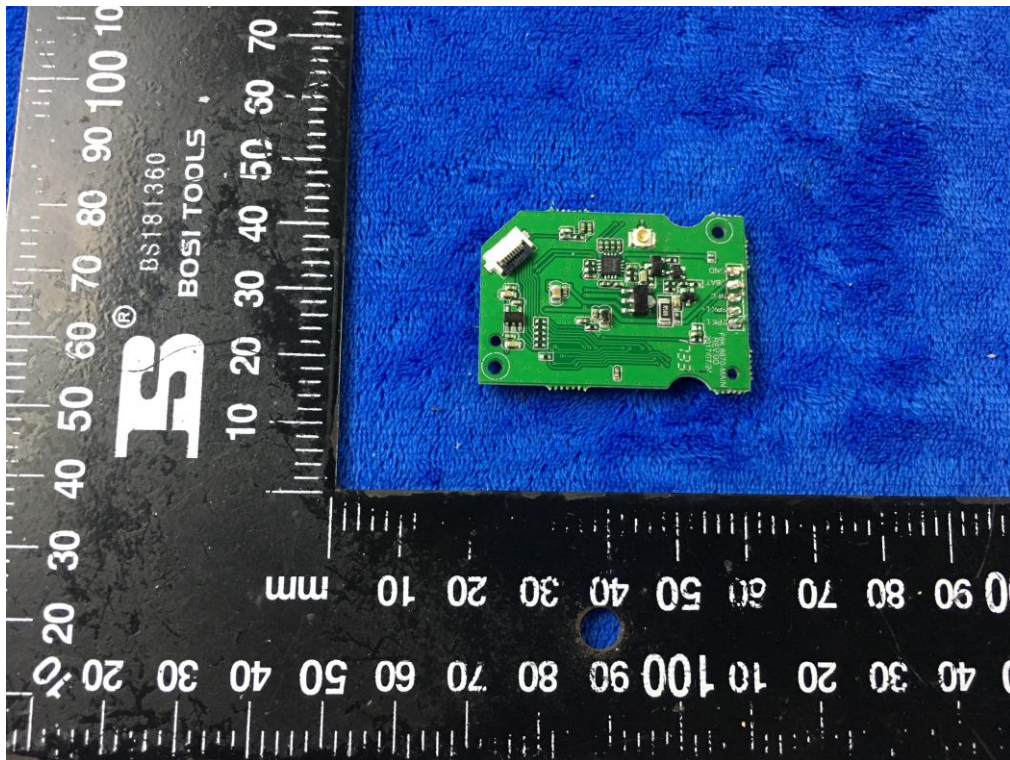

Connect board - Front View

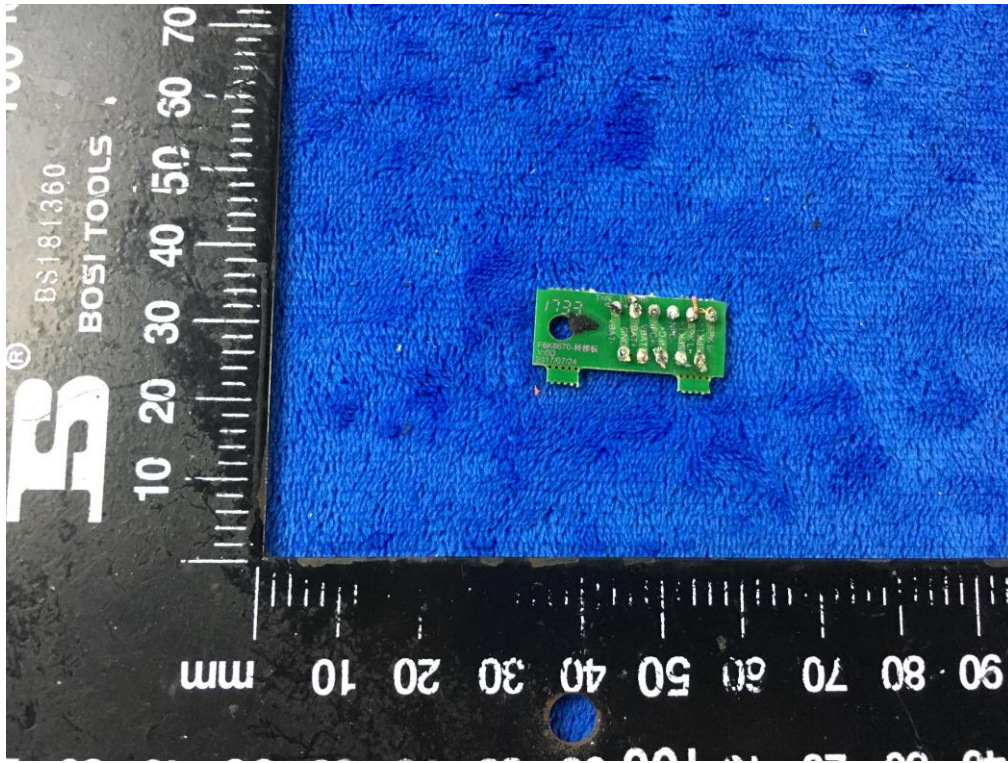

Connect board- Rear View

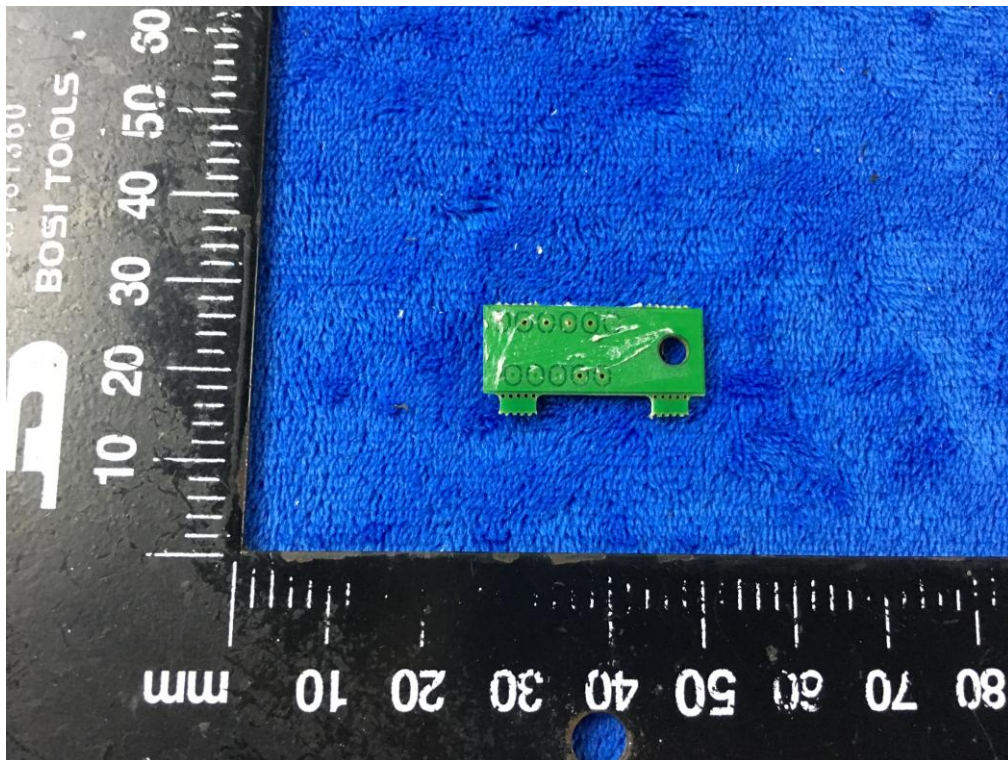

BT/BLE - Antenna View

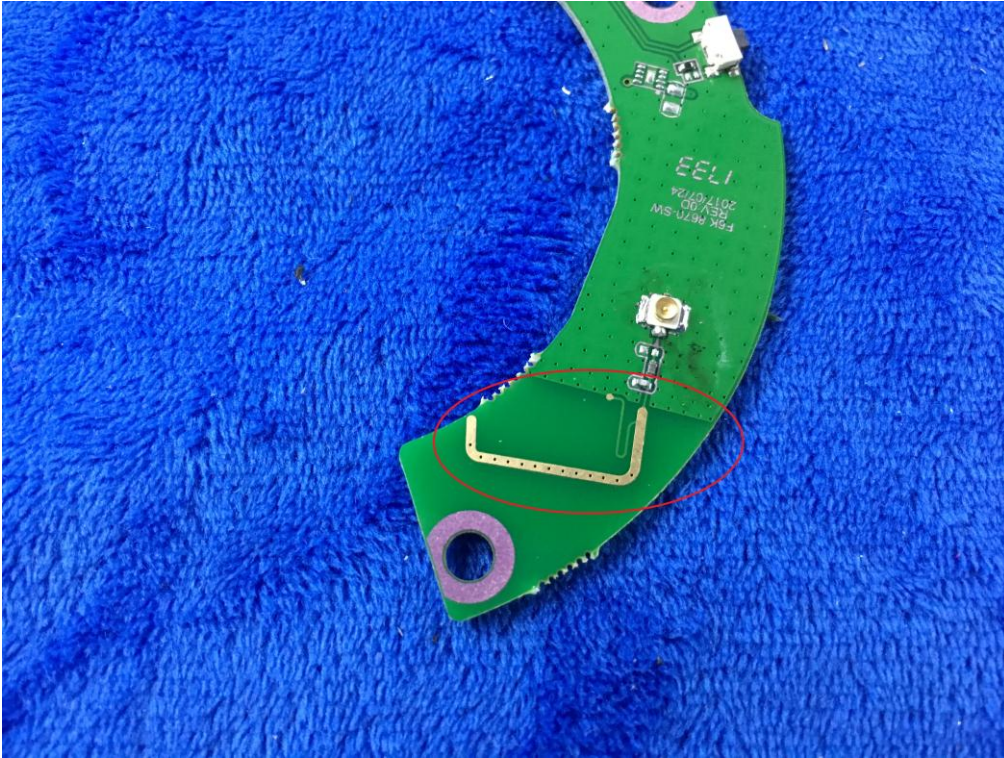

Annex B.iii. Photograph: Test Setup Photo



Conducted Emissions Test Setup Front View



Conducted Emissions Test Setup Side View



Radiated Spurious Emissions Test Setup Below 1GHz

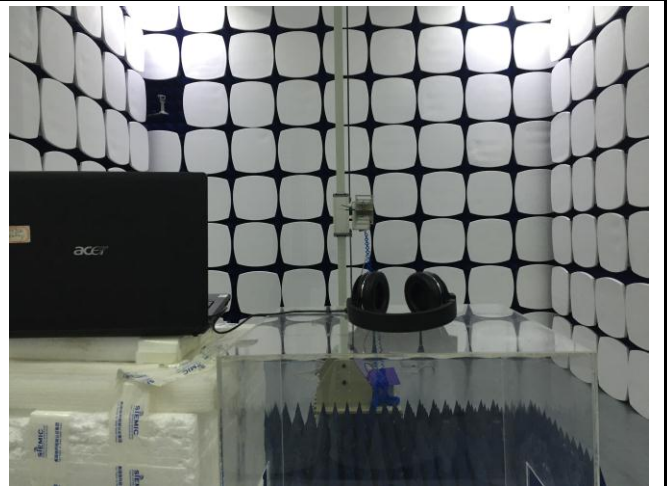

Radiated Spurious Emissions Test Setup Above
1GHz

Annex C. TEST SETUP AND SUPPORTING EQUIPMENT

Annex C.ii. TEST SET UP BLOCK

Block Configuration Diagram for AC Line Conducted Emissions

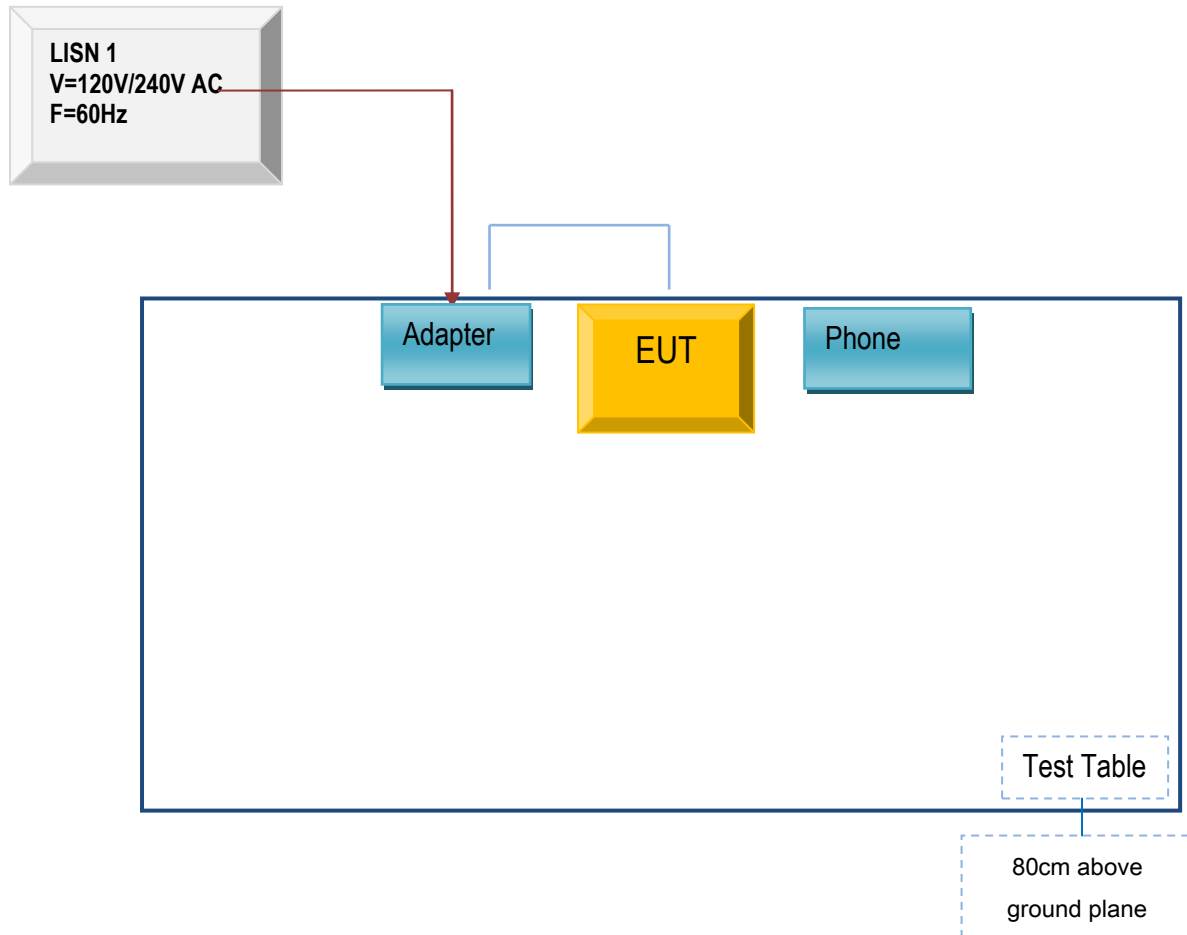

Block Configuration Diagram for Radiated Emissions (Below 1GHz) .

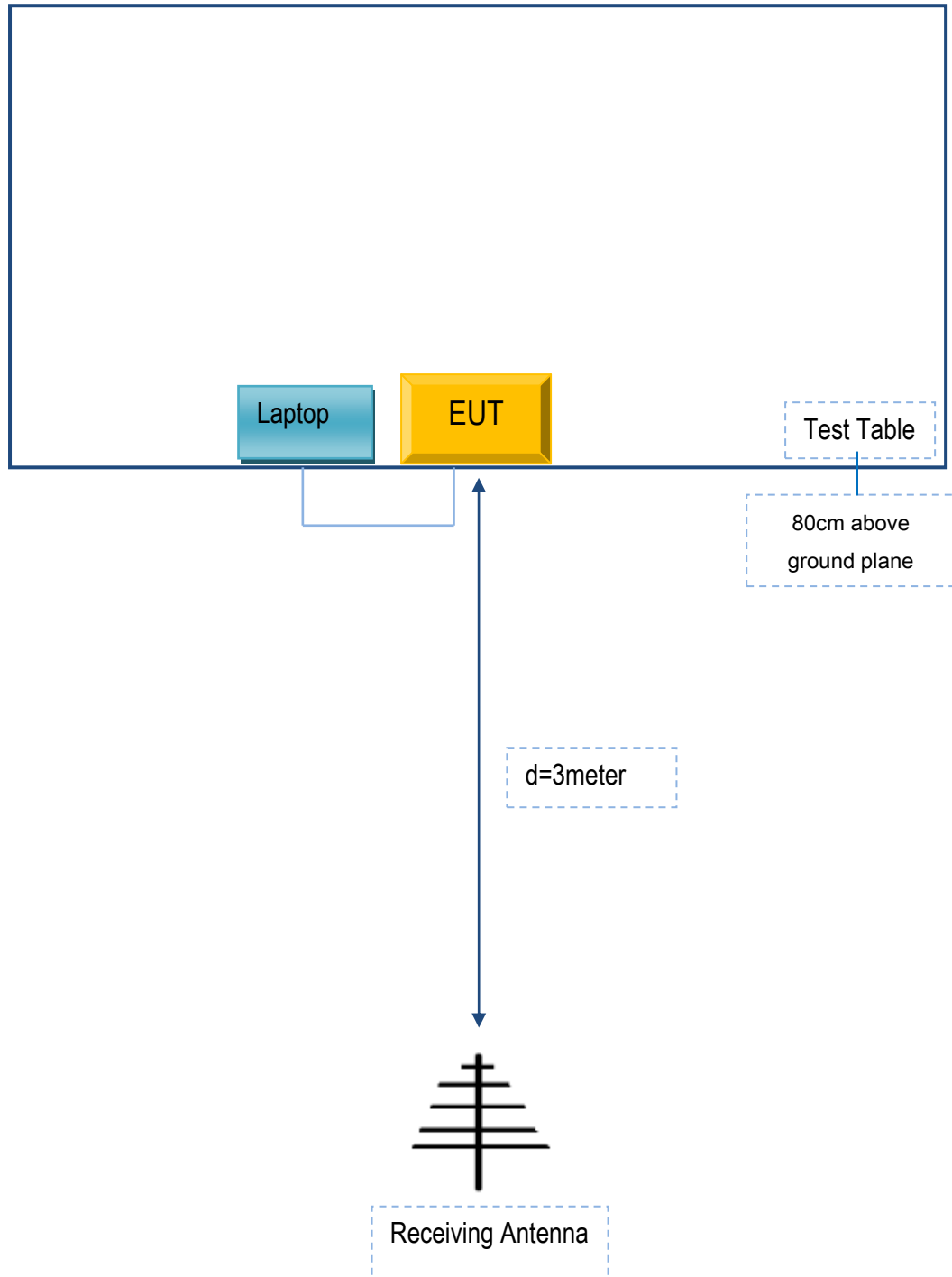

Block Configuration Diagram for Radiated Emissions (Above 1GHz) .

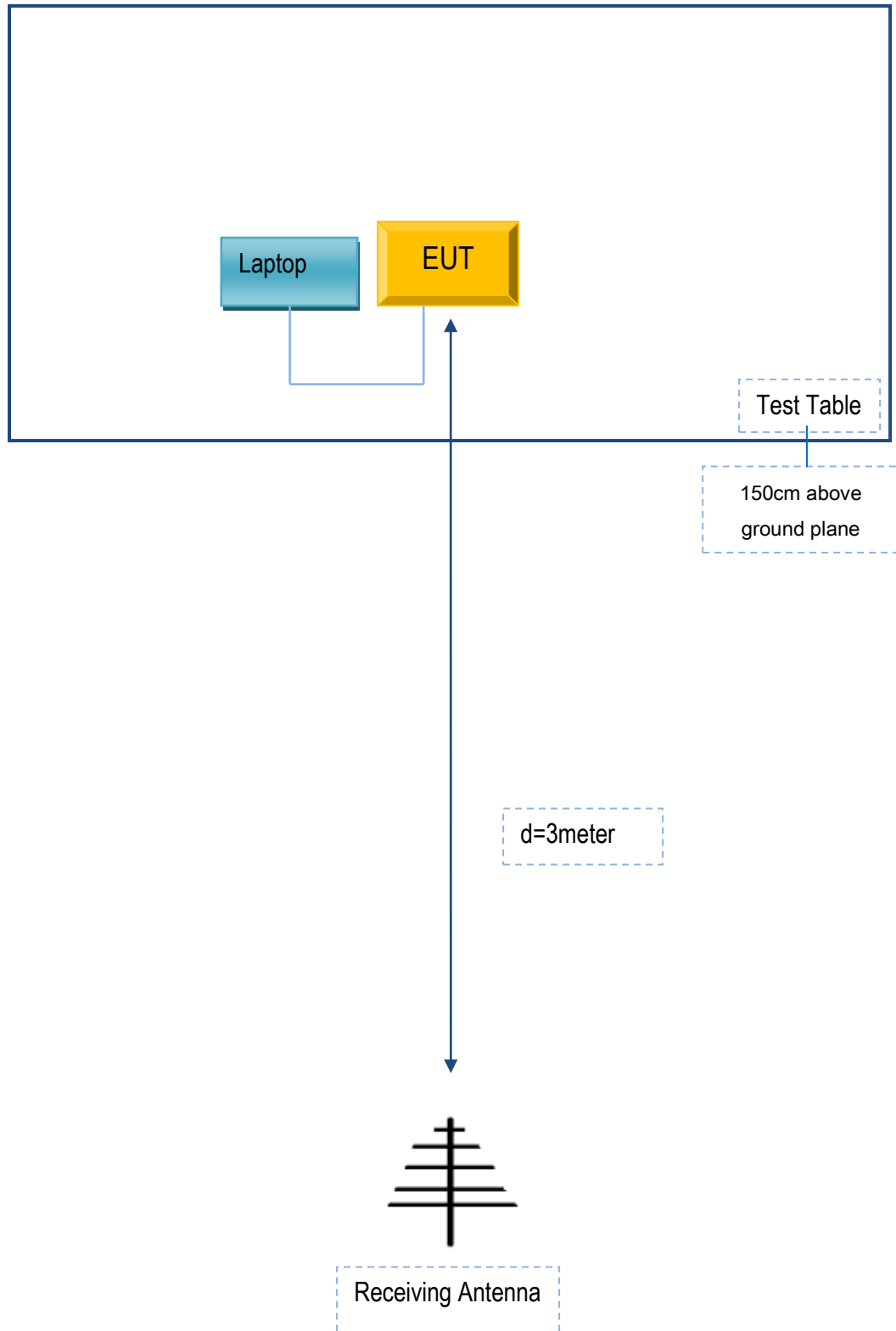

Annex C. ii. SUPPORTING EQUIPMENT DESCRIPTION

The following is a description of supporting equipment and details of cables used with the EUT.

Supporting Equipment:

Manufacturer	Equipment Description	Model	Serial No
DCA	Adaptor	E2164A	N/A
TCL	Telephone	TCL03	N/A
Lenovo	Laptop	E40	N/A

Supporting Cable:

Cable type	Shield Type	Ferrite Core	Length	Serial No
USB Cable	Un-shielding	No	0.8m	N/A
USB Cable	Un-shielding	No	0.8m	N/A

Test Report	17071137-FCC-R2
Page	66 of 67

Annex D. User Manual / Block Diagram / Schematics / Partlist

Please see the attachment

Test Report	17071137-FCC-R2
Page	67 of 67

Annex E. DECLARATION OF SIMILARITY

N/A