

Wireless Smart Audio Module Datasheet

(A97)

Rev. 0.3

September 12, 2021

FCC ID:2ANOG-A97

Doc Title	Wireless Smart Audio Module-A97 Datasheet	Number	WMB20210203
		Version	0.4

HISTORY

Revision	Date	Description
0.1	02/09/2021	Datasheet Release
0.2	04/23/2021	Add Z dimension
0.3	06/28/2021	Update pin description
0.4	07/30/2021	Update Bluetooth version

Linkplay Confidential

Doc Title	Wireless Smart Audio Module-A97 Datasheet	Number	WMB20210203
		Version	0.4

INDEX

1.	Overview.....	4
1.1.	Parameter.....	4
2.	Hardware Description.....	8
2.1.	Description of Hardware Interface.....	8
2.2.	Mechanical Dimension.....	10
2.3.	Module Overview and Height Limit.....	13
2.4.	External Antenna.....	18
2.5.	Power on Sequence.....	19
2.6.	USB OTG Port.....	19
3.	Software Introduction.....	20
3.1.	Feature list.....	20
3.2.	APP support.....	21
4.	Module Environmental and Package.....	21
4.1.	Environmental Ratings.....	21
4.2.	Electrostatic Discharge Specifications.....	21

Linkplay Confidential

Doc Title	Wireless Smart Audio Module-A97 Datasheet	Number	WMB20210203
		Version	0.4

1. Overview

Linkplay Wireless Smart Audio module-A97 is our 4rd generation smart audio modules developed to be used in the connected speaker, sound bar and other connected audio devices. It integrates the low power AMPAK AP6256 WLAN-BT chip and Allwinner R328 application processor. R328 is a highly integrated dual-core SoC targeted for audio application markets. The R328 integrates a dual-core ARM Cortex™-A7 operating up to 1.2GHz. An extensive set of audio interfaces such as audio codec, I2S/PCM, DMIC, one wire audio (OWA) are included for microphone voice wake-up/recognition/pre-processing/playback applications on connected audio products. In addition, mic activity detector (MAD) supports low power consumption wake-up function to reduce standby power consumption.

To reduce the BOM cost, DDR DRAM die is embedded for the R328. And the R328 comes with extensive connectivity and interfaces, such as USB, SPI, UART, TWI, etc.

Security functions are enabled and accelerated by hardware crypto engine, secure boot and secure efuse, etc. The small footprint with low-power consumption greatly reduces the PCB layout resource.

A97 module supports IEEE 802.11 a/b/g/n/ac 2.4GHz and 5GHz. It also supports BT5.2 with EDR and BLE.

A97 module also provides USB, I2S, PWM, TWI, PDM, SPI, UART etc. interfaces.

The firmware is fully compatible with Apple Airplay and digital living network alliance (DLNA) streaming standards. It supports Hi-Fi audio up to 192KHz, 24-bit with most popular audio formats. It supports multi-room and multi-channel audio streaming with perfect synchronization.

With this module, you can play the music on your speaker wirelessly from iPhone, iPad, iPod touch, Android devices or PC. More important, it enables the traditional speaker system to become the Internet enabled device through the wired or wireless connection provided by the module. Thus, you could freely playback any Internet audio contents such as music, podcast, radio or either the accompany audio in the movie directly from the Internet.

Features

- Allwinner R328 application processor
- Embedded with DDR DRAM 128MB
- SPI NAND FLASH 128MB
- Support IEEE 802.11 a/b/g/n/ac
- Support BT5.2 with EDR and BLE

Application

- Connected speaker, sound bar
- Connected audio devices

1.1. Parameter

Type	Items	Performance
Wi-Fi	Certification	WFA111066
	WLAN Standard	IEEE 802.11 a/b/g/n/ac Wi-Fi compliant

Doc Title	Wireless Smart Audio Module-A97 Datasheet	Number	WMB20210203
		Version	0.4

Wi-Fi (2.4G)	Frequency Range	2.400 GHz ~ 2.4835 GHz (2.4 GHz ISM Band)
	Number of Channels	Ch1 ~ Ch13
	Modulation	802.11b : DQPSK, DBPSK, CCK
		802.11g/n : OFDM /64-QAM,16-QAM, QPSK, BPSK
	Max EIRP	17.75dBm
	Receive Sensitivity (Tolerance \pm 2 dB CCK modulation PER \cong 8%、OFDM modulation PER \cong 10%) @8% PER	802.11b 1Mbps -96 dBm
		802.11b 2Mbps -90 dBm
		802.11b 5.5Mbps -88 dBm
		802.11b 11Mbps -87 dBm
		802.11g 6Mbps -91 dBm
		802.11g 9Mbps -88 dBm
		802.11g 12Mbps -87 dBm
		802.11g 18Mbps -85 dBm
		802.11g 24Mbps -83 dBm
		802.11g 36Mbps -80 dBm
		802.11g 48Mbps -76 dBm
		802.11g 54Mbps -73 dBm
		802.11n 20MHz MCS0 -90 dBm
		802.11n 20MHz MCS1 -85 dBm
		802.11n 20MHz MCS2 -84 dBm
		802.11n 20MHz MCS3 -80 dBm
		802.11n 20MHz MCS4 -77 dBm
	802.11n 20MHz MCS5 -75 dBm	
802.11n 20MHz MCS6 -72 dBm		
802.11n 20MHz MCS7 -71 dBm		
Maximum Input Level	802.11b : -10 dBm	
	802.11g/n : -20 dBm	
Antenna Interface	External: I-PEX I with 3.13 dBi peak gain	
Wi-Fi (5G)	WLAN Standard	IEEE 802.11a/n/ac 1x1 & Wi-Fi compliant
	Frequency Range	5.15 ~ 5.35GHz、5.47 ~ 5.725GHz、5.725 ~ 5.85GHz (5GHz UNII Band)
	Number of Channels	5.18~5.35GHz: Ch36 ~ Ch64
		5.5~5.7GHz: Ch100 ~ Ch140
		5.745~5.825GHz: Ch149 ~ Ch165
	Modulation	802.11a : OFDM /64-QAM、16-QAM、QPSK、BPS
802.11n : OFDM /64-QAM、16-QAM、QPSK、BPSK		
802.11ac : OFDM /256-QAM、OFDM /64-QAM、16-QAM、QPSK、BPSK		
Max EIRP	5180-5240GHZ, 15.96dBm	
	5260-5320GHZ, 16.65dBm	
	5500-5700GHZ, 16.99dBm	

Doc Title	Wireless Smart Audio Module-A97 Datasheet	Number	WMB20210203
		Version	0.4

<p>Receive Sensitivity (Tolerance \pm 2 dB OFDM modulation PER \cong 10%)</p>	5745-5825GHZ, 12.77dBm
	802.11a 6Mbps -92 dBm
	802.11a 9Mbps -89 dBm
	802.11a 12Mbps -88 dBm
	802.11a 18Mbps -86 dBm
	802.11a 24Mbps -82 dBm
	802.11a 36Mbps -79 dBm
	802.11a 48Mbps -75 dBm
	802.11a 54Mbps -74 dBm
	802.11n 20MHz MCS0 -91 dBm
	802.11n 20MHz MCS1 -88 dBm
	802.11n 20MHz MCS2 -85 dBm
	802.11n 20MHz MCS3 -82 dBm
	802.11n 20MHz MCS4 -78 dBm
	802.11n 20MHz MCS5 -74 dBm
	802.11n 20MHz MCS6 -73 dBm
	802.11n 20MHz MCS7 -72 dBm
	802.11n 40MHz MCS0 -89 dBm
	802.11n 40MHz MCS1 -85 dBm
	802.11n 40MHz MCS2 -83 dBm
	802.11n 40MHz MCS3 -79 dBm
	802.11n 40MHz MCS4 -76 dBm
	802.11n 40MHz MCS5 -71 dBm
	802.11n 40MHz MCS6 -70 dBm
	802.11n 40MHz MCS7 -68 dBm
	802.11ac 20MHz MCS0 -90 dBm
	802.11ac 20MHz MCS1 -87 dBm
	802.11ac 20MHz MCS2 -84 dBm
	802.11ac 20MHz MCS3 -81 dBm
	802.11ac 20MHz MCS4 -77 dBm
	802.11ac 20MHz MCS5 -73 dBm
	802.11ac 20MHz MCS6 -71 dBm
	802.11ac 20MHz MCS7 -70 dBm
	802.11ac 20MHz MCS8 -67 dBm
802.11ac 40MHz MCS0 -88 dBm	
802.11ac 40MHz MCS1 -83 dBm	
802.11ac 40MHz MCS2 -81 dBm	
802.11ac 40MHz MCS3 -78 dBm	
802.11ac 40MHz MCS4 -75 dBm	
802.11ac 40MHz MCS5 -70 dBm	
802.11ac 40MHz MCS6 -68 dBm	

Doc Title	Wireless Smart Audio Module-A97 Datasheet	Number	WMB20210203
		Version	0.4

		802.11ac 40MHz MCS7 -66 dBm	
		802.11ac 40MHz MCS8 -65 dBm	
		802.11ac 40MHz MCS9 -63 dBm	
		802.11ac 80MHz MCS0 -85 dBm	
		802.11ac 80MHz MCS1 -82 dBm	
		802.11ac 80MHz MCS2 -78 dBm	
		802.11ac 80MHz MCS3 -74 dBm	
		802.11ac 80MHz MCS4 -71 dBm	
		802.11ac 80MHz MCS5 -69 dBm	
		802.11ac 80MHz MCS6 -65 dBm	
		802.11ac 80MHz MCS7 -63 dBm	
		802.11ac 80MHz MCS8 -61 dBm	
		802.11ac 80MHz MCS9 -60 dBm	
		Maximum Input Level	802.11a/n : -20 dBm 802.11ac : -30 dBm
	Antenna Reference	External: I-PEX I with 3.73 dBi peak gain	
Bluetooth	Certification	D053921	
	Bluetooth Standard	GFSK、DQPSK、8DPSK、LE(1Mbps)、2LE(2Mbps)	
	Antenna Interface	External: I-PEX I shared with Wi-Fi 3.13 dBi peak gain	
	Frequency Band	2402 MHz ~ 2480 MHz	
	Number of Channels	79 channels for classic、40 channels for BLE	
	Modulation	FHSS, GFSK, DPSK, DQPSK	
	Max EIRP	9.65dBm	
	Sensitivity @ BER=0.1% for GFSK (1Mbps)	-86 dBm, Typical	
	Sensitivity @ BER=0.01% for $\pi/4$ -DQPSK (2Mbps)	-87 dBm, Typical	
	Sensitivity @ BER=0.01% for 8DPSK (3Mbps)	-83 dBm, Typical	
	Sensitivity @ BER=0.01% for LE (1Mbps)	-90 dBm, Typical	
	Sensitivity @ BER=0.01% for LE (2Mbps)	-90 dBm, Typical	
		Maximum Input Level	GFSK (1Mbps): -20dBm $\pi/4$ -DQPSK (2Mbps) : -20dBm 8DPSK (3Mbps) : -20dBm
	Hardware	Working Voltage	3.5-5.5V (Typical 5V)
Working Current		150mA (STA mode)	
Standby Current		TBD	
Wi-Fi Working Distance		2.4G 80 meters/5G 150meters	
IO Extension		USB, A-MIC, LINEOUT, I2S, I2C, PWM, PDM, UART	
Dimension		58-pin dual-row pin headers, 43.95mm x 30mm	

Doc Title	Wireless Smart Audio Module-A97 Datasheet	Number	WMB20210203
		Version	0.4

Table1- 1 A97 General Parameters

2. Hardware Description

2.1. Description of Hardware Interface

A97 series provides 58-pin dual-row pitch 2.0mm pin headers connector. Detailed information as below.

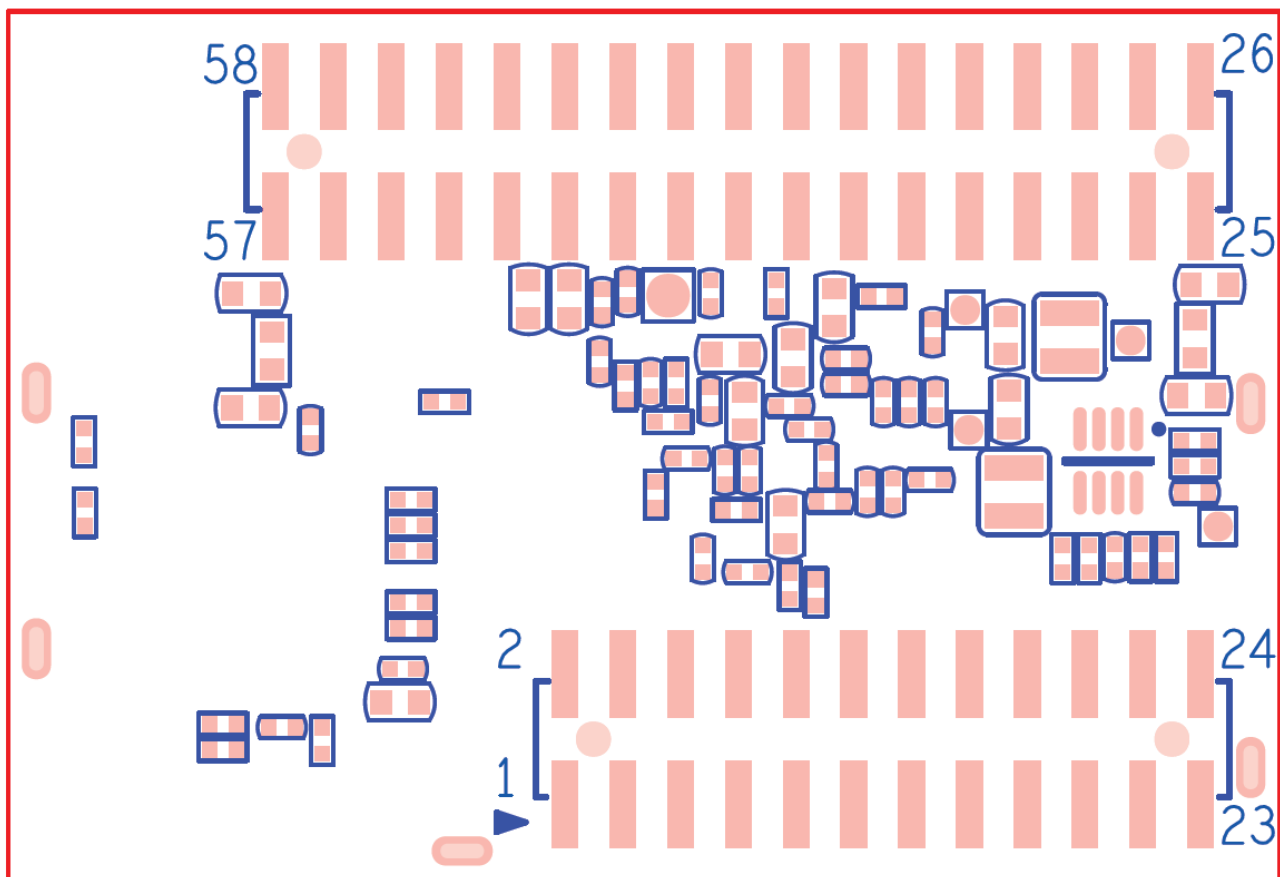

Figure 2- 1 A97 Pin Number Definition

Pin Description:

Pin No.	Pin Name	Type	Function	Remark
1, 2, 8,10,11,12, 19,20,23,24 ,25,26,45,4 6,57,58	GND	P	Digital ground	
27,28	VDD_5V	P	Power supply input > 500mA	
3	USB_DM	AIO	USB Data Signal DM	
4	USB_DP	AIO	USB Data Signal DP	

Doc Title	Wireless Smart Audio Module-A97 Datasheet	Number	WMB20210203
		Version	0.4

5	USB_ID/PH8	I	USB ID/GPIO	
6	MBIAS	O	Master Analog Microphone Bias Voltage Output	
7	GPADC2	AI/PU	General Purpose ADC Input Channel 2	Power domain: 1.8V
9	GPADC0	AI/PU	General Purpose ADC Input Channel 0	Internal pull up to 1.8V (Pull-up resistor 10K)
13	MICIN2P	AI	Microphone Positive Input 2	
14	MICIN2N	AI	Microphone Negative Input 2	
15	MICIN1P	AI	Microphone Positive Input 1	
16	MICIN1N	AI	Microphone Negative Input 1	
17	MICIN3P	AI	AEC Positive Signal Input	
18	MICIN3N	AI	AEC Negative Signal Input	
21	LINEOUTN	AO	Differential Mono Negative Output	
22	LINEOUTP	AO	Differential Mono Positive Output	
29	UART0_RX	I	UART0 Data Receive	
30	EFUSE_EN	O	EFUSE power Enable/Disable	Reserved for factory test
31	PH7	I	GPIO	
32	PH6	O	GPIO	
33	TWI1_SDA	IO	TWI1 Serial Data Signal	Internal pull up to 3.3V (Pull-up resistor 10K)
34	USB_SW/PE2	O	USB Bus Switch Control/GPIO	
35	UART3_TX/PH4	O	UART3 Data Transmit/GPIO	
36	UART3_RX/PH5	I	UART3 Data Receive/GPIO	
37	TWI1_SCK	IO	TWI1 Serial Clock Signal	Internal pull up to 3.3V (Pull-up resistor 10K)
38	AUXIN_DET/PH9	I	AUXIN Cable Insert Detection/GPIO	
39	PWM0/PB0	O	Pulse Width Modulation Output Channel 0/GPIO	
40	OWA_OUT	O	One Wire Audio Output	
41	UART0_TX	O	UART0 Data Transmit	
42	I2S1_MCLK	O	I2S1 Master Clock	
43	I2S0_MCLK	O	I2S0 Master Clock	
44	DMIC_CLK	O	Digital Microphone Clock Output	
47	PWM6/PB6	O	Pulse Width Modulation Output Channel 6/GPIO	
48	PWM7/PB7	O	Pulse Width Modulation Output Channel 7/GPIO	
49	I2S0_LRCK	IO	I2S0/PCM0 Left Right Clock	
50	I2S1_BCLK	IO	I2S1/PCM1 Bit Clock	
51	I2S0_BCLK	IO	I2S0/PCM0 Bit Clock	
52	I2S1_LRCK	IO	I2S1/PCM1 Left Right Clock	

Doc Title	Wireless Smart Audio Module-A97 Datasheet	Number	WMB20210203
		Version	0.4

53	I2S0_DIN	I	I2S0/PCM0 Serial Data Input	
54	I2S0_DOUT	O	I2S0/PCM0 Serial Data Output	
55	DMIC_DATA1	I	Digital Microphone Data Input	
56	I2S1_DIN	I	I2S1/PCM1 Serial Data Input	

Table 2- 1 A97 Module Pin Description

Notes:

- I: Input
- O: Output
- IO: Input and Output
- P: Power
- PU: Internal Pull Up
- PD: Internal Pull Down
- AI: Analog Input
- AO: Analog Output
- AIO: Analog Input and Output

2.2. Mechanical Dimension

A97 module has the dimension of 30mm x 39mm. The detailed layout will be given shortly below.

Unit: mm

A97 module uses dual row pin headers connector. The matching female socket as below.

Double-row patch male connector dimensions:

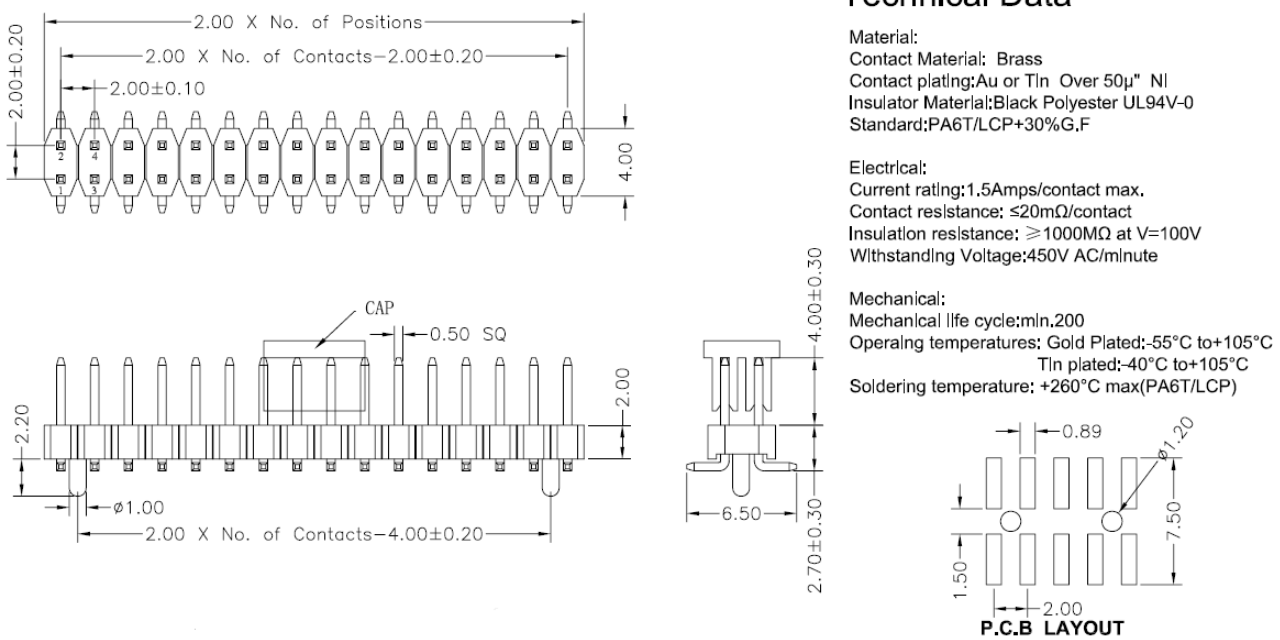
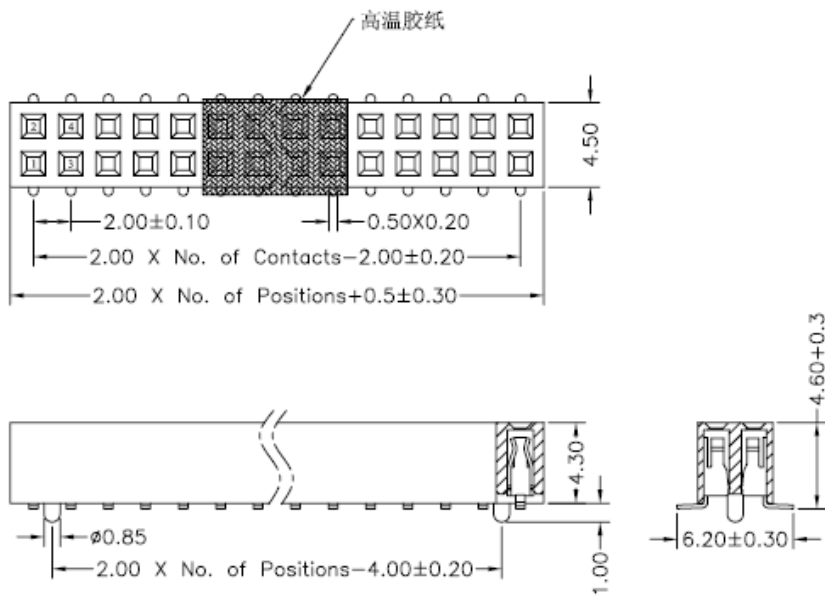

Figure 2-2 Male Pin Header Dimensions

Double-row patch female connector dimensions:

Doc Title	Wireless Smart Audio Module-A97 Datasheet	Number	WMB20210203
		Version	0.4



Technical Data

Material:
 Contact Material: Brass
 Contact plating: Au Over $30\mu^* \text{ Ni}$
 Insulator Material: Black Polyester UL94V-0
 Standard: PA6T+30%G.F

Electrical:
 Current rating: 1.5Amps/contact max.
 Contact resistance: $\leq 20\text{m}\Omega/\text{contact}$
 Insulation resistance: $\geq 1000\text{M}\Omega$ at $V=100\text{V}$
 Withstanding Voltage: 450V AC/minute

Mechanical:
 Mechanical life cycle: min.200
 Operating temperatures: Gold Plated: -55°C to $+105^\circ\text{C}$
 Tin plated: -40°C to $+105^\circ\text{C}$
 Soldering temperature: $+260^\circ\text{C}$ max(PA6T)

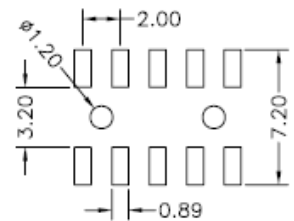
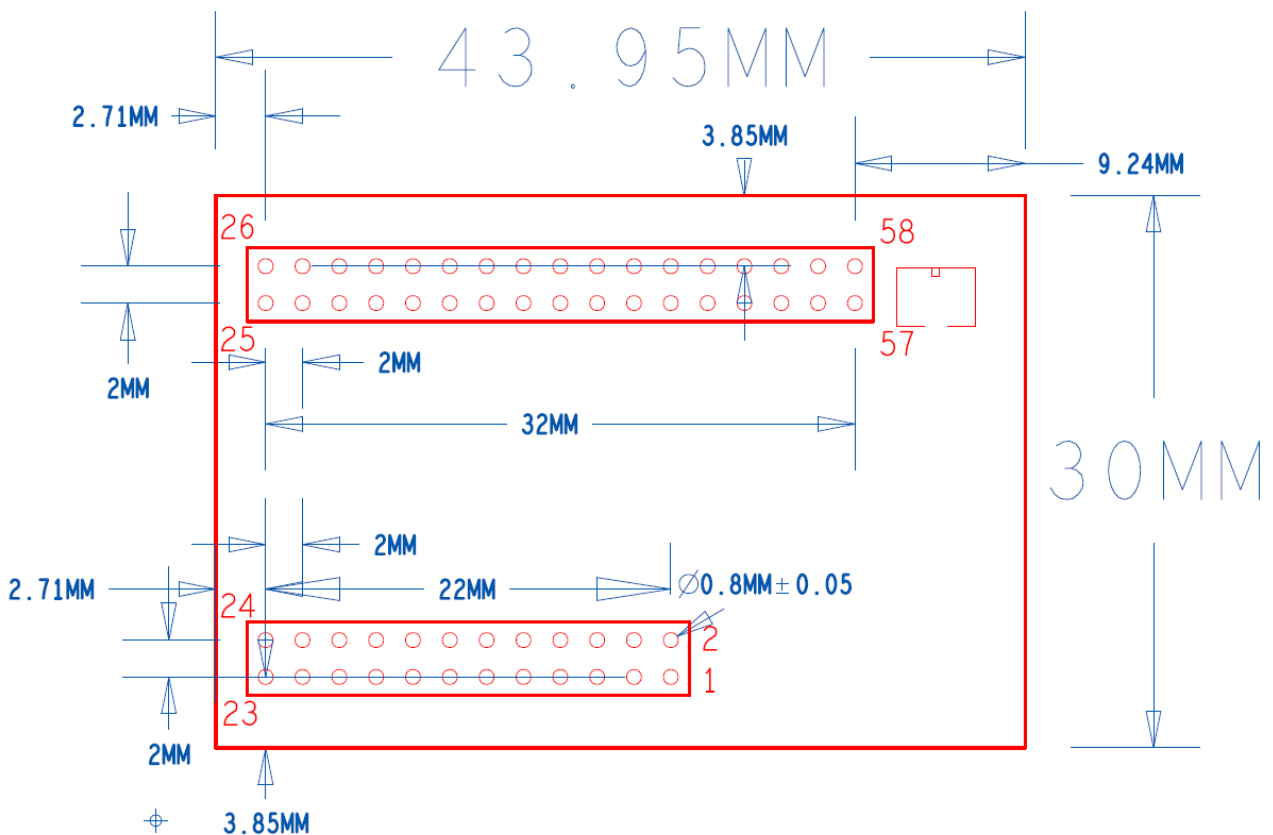

Figure 2-3 Female Pin Header Dimensions

We recommend two ways to connect A97 module:

- A97 module is directly soldered on board. The dimension of A97 module interface as below.



Doc Title	Wireless Smart Audio Module-A97 Datasheet	Number	WMB20210203
		Version	0.4

Figure 2-4 A97 on Board Dimensions

b) Matching female sockets are soldered on board. Recommended land pattern as below.

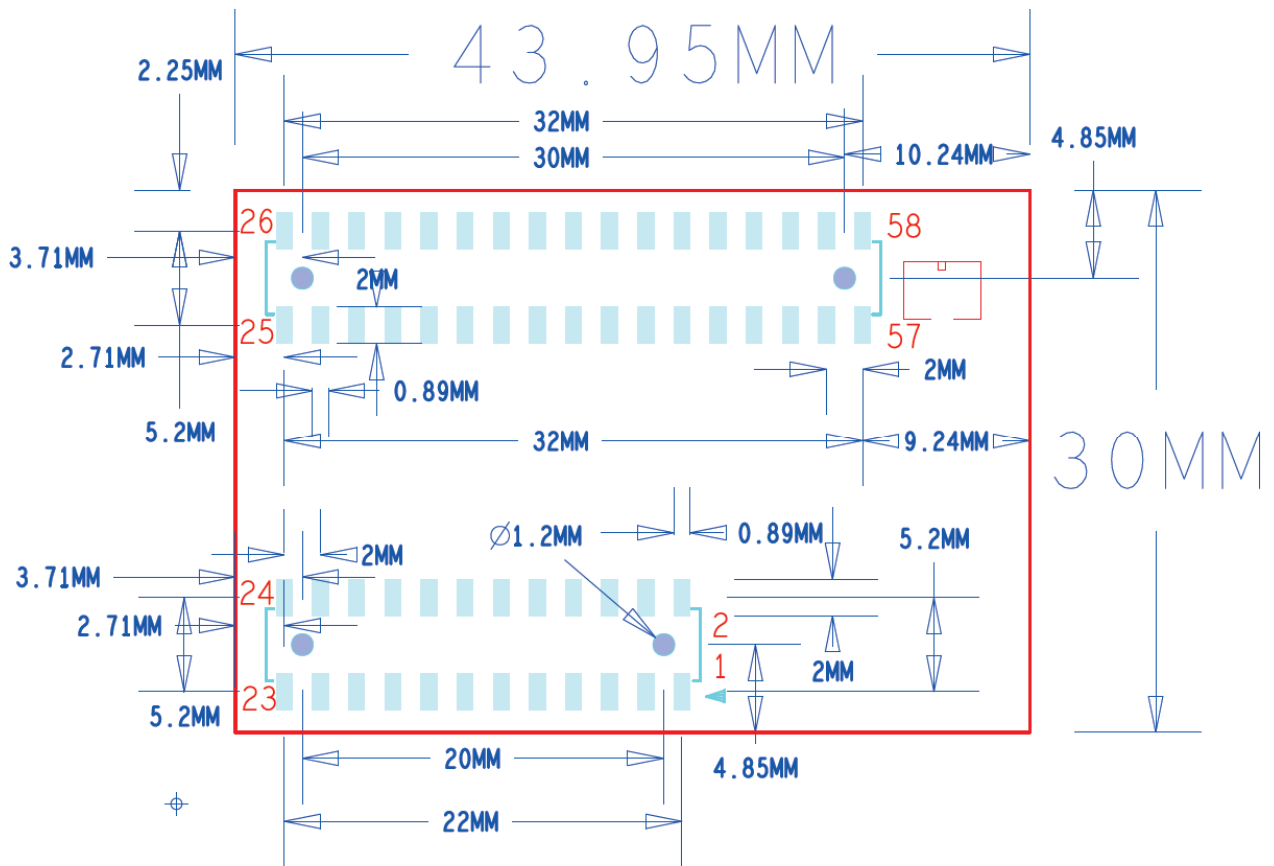

Figure 2-5 A97 Female Socket Dimensions

Linkplay

Doc Title	Wireless Smart Audio Module-A97 Datasheet	Number	WMB20210203
		Version	0.4

2.3. Module Overview and Height Limit



Figure 2-6 Top View

Linkplay

Doc Title	Wireless Smart Audio Module-A97 Datasheet	Number	WMB20210203
		Version	0.4

TOP
Other height 0.7-1.0mm

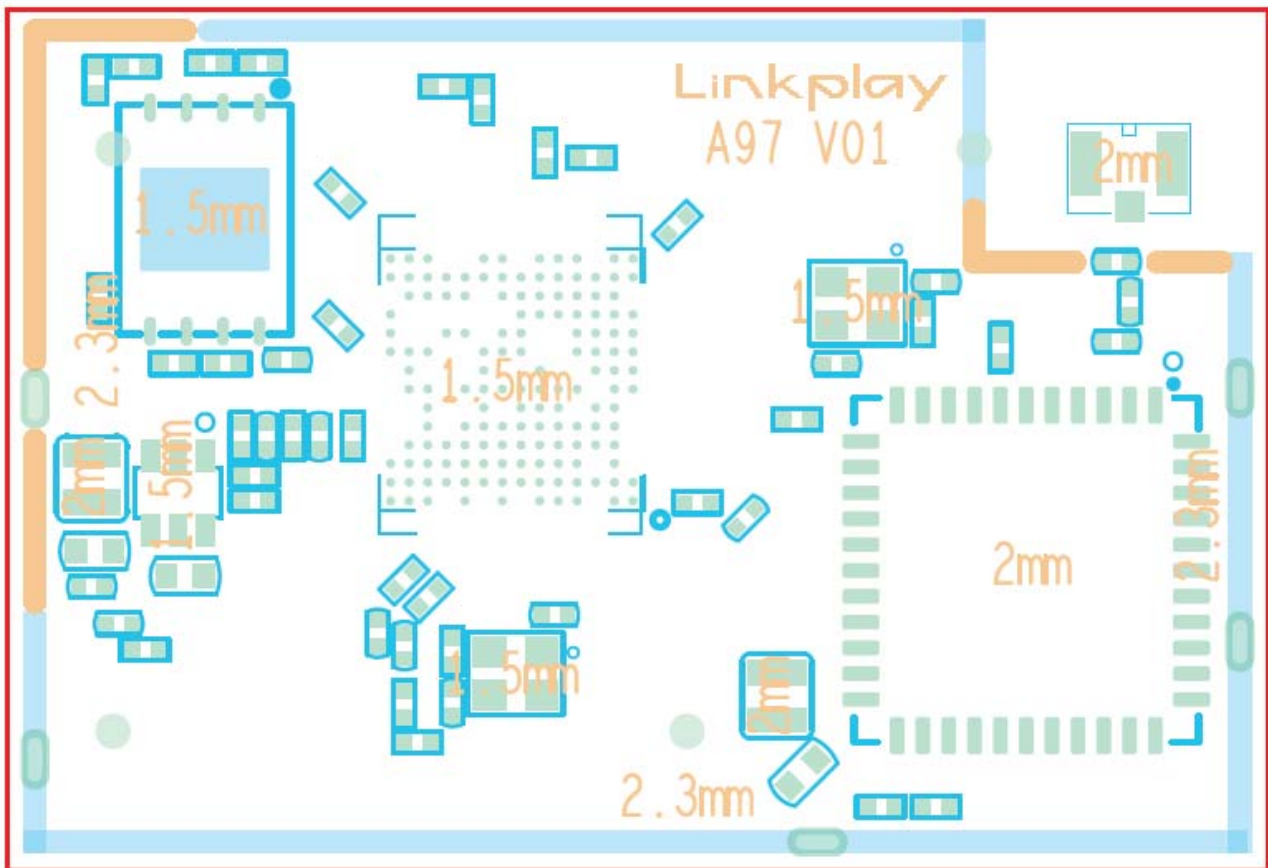

Figure 2-7 Height Limit Top

Linkplay

Doc Title	Wireless Smart Audio Module-A97 Datasheet	Number	WMB20210203
		Version	0.4

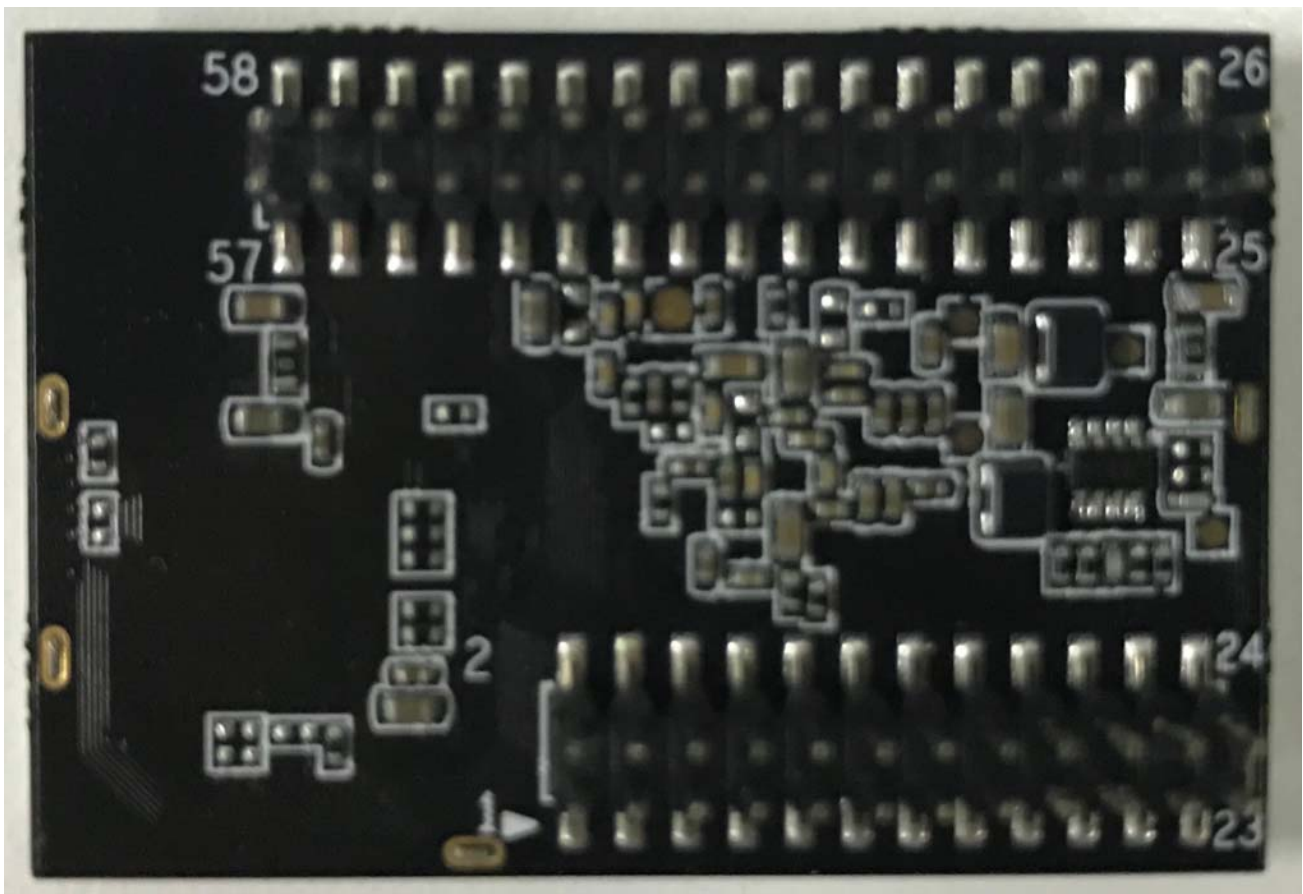

Figure 2-8 Bottom View

Doc Title	Wireless Smart Audio Module-A97 Datasheet	Number	WMB20210203
		Version	0.4

BOTTOM
Other height 0.7-1.0mm

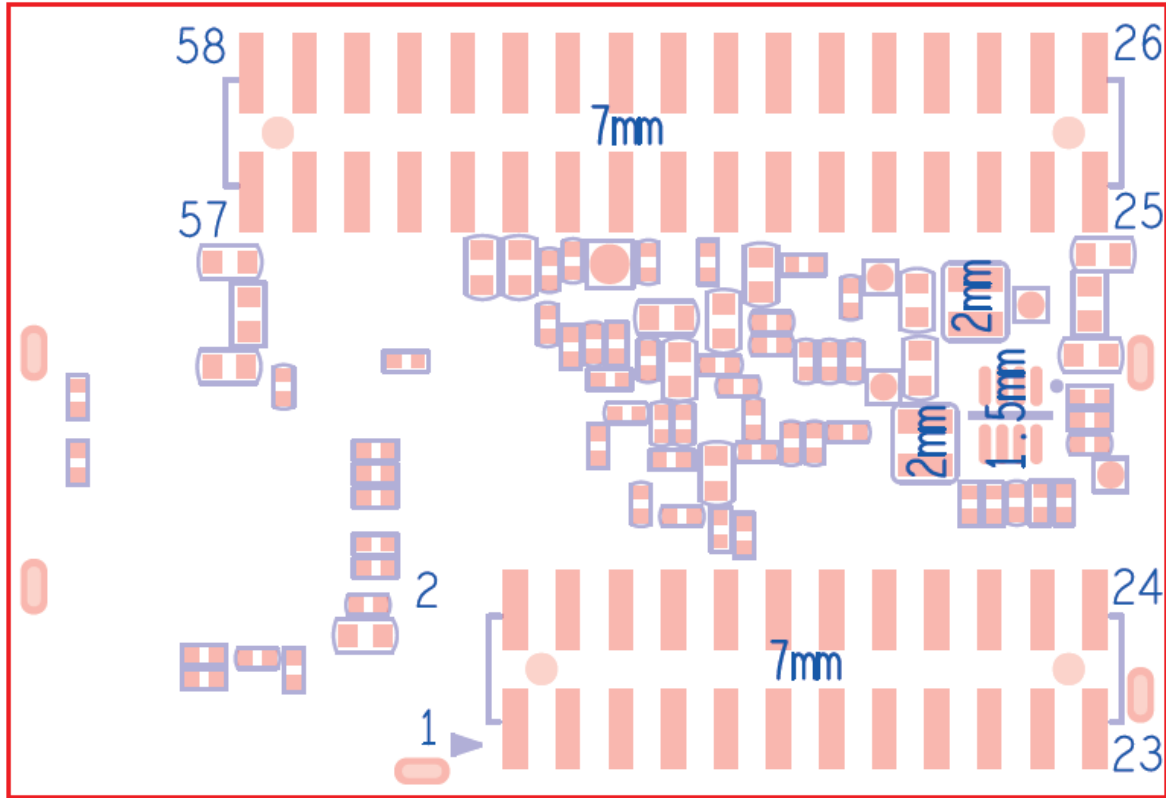

Figure 2-9 Height Limit Bottom

Linkplay

Doc Title	Wireless Smart Audio Module-A97 Datasheet	Number	WMB20210203
		Version	0.4

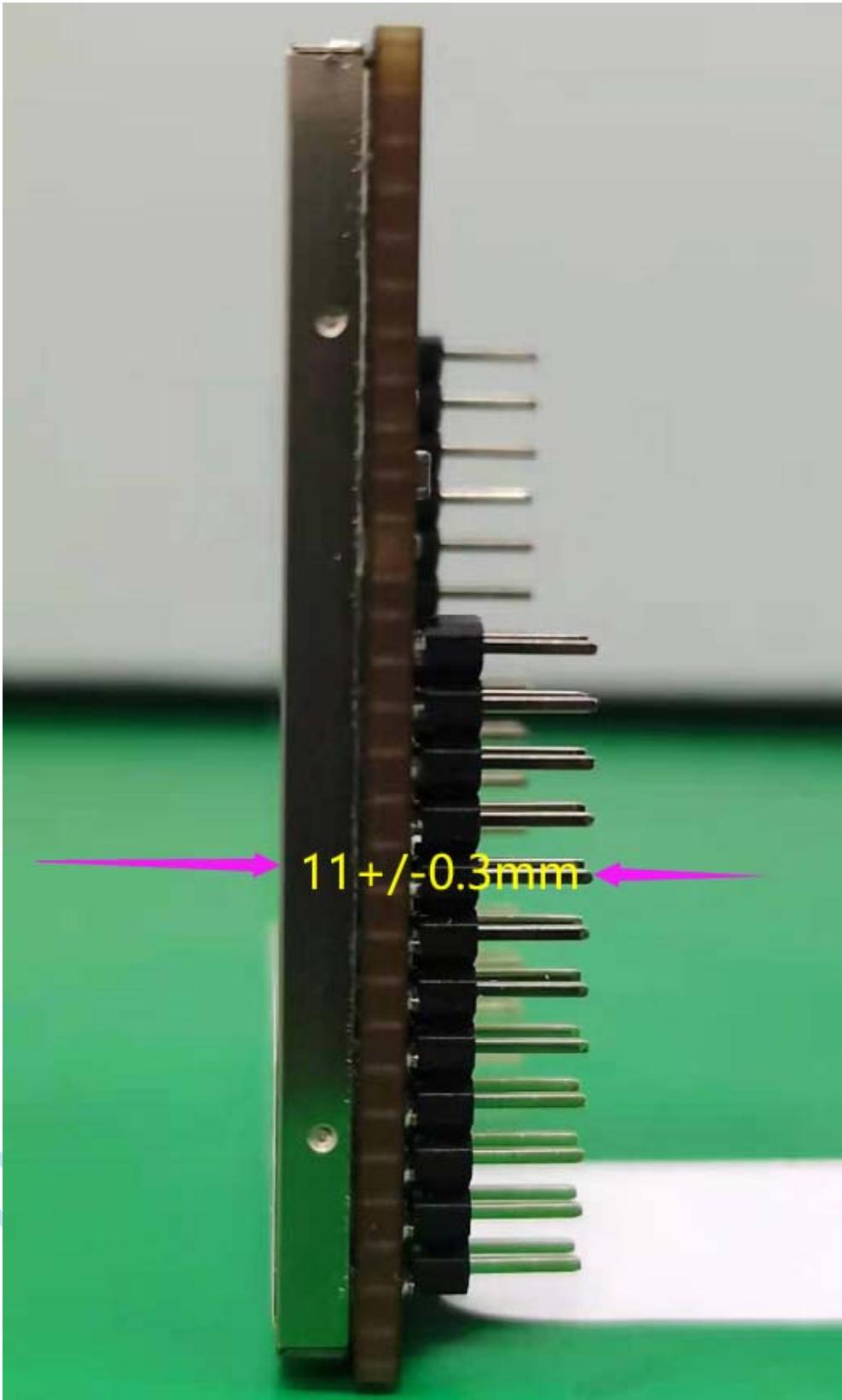

Figure 2- 10 Z dimension

Doc Title	Wireless Smart Audio Module-A97 Datasheet	Number	WMB20210203
		Version	0.4

2.4. External Antenna

A97 series provides Gen-1 U.FL connector for external WLAN-BT antenna. In order to get the best performance, please tune the antenna based on whole device and meet the requirement of WLAN-BT standard. The detailed parameters are shown in the following table.

Item	Parameter
Frequency range	2.4 ~ 2.5GHz/4.9 ~ 5.8GHz
Impedance	50 Ohm
VSWR	2 (Max.)
Reflection loss	-10dB (Max.)
Connector	IPX, U.FL or populate directly

Table 2-2 External Antenna Parameters

Doc Title	Wireless Smart Audio Module-A97 Datasheet	Number	WMB20210203
		Version	0.4

2.5. Power on Sequence

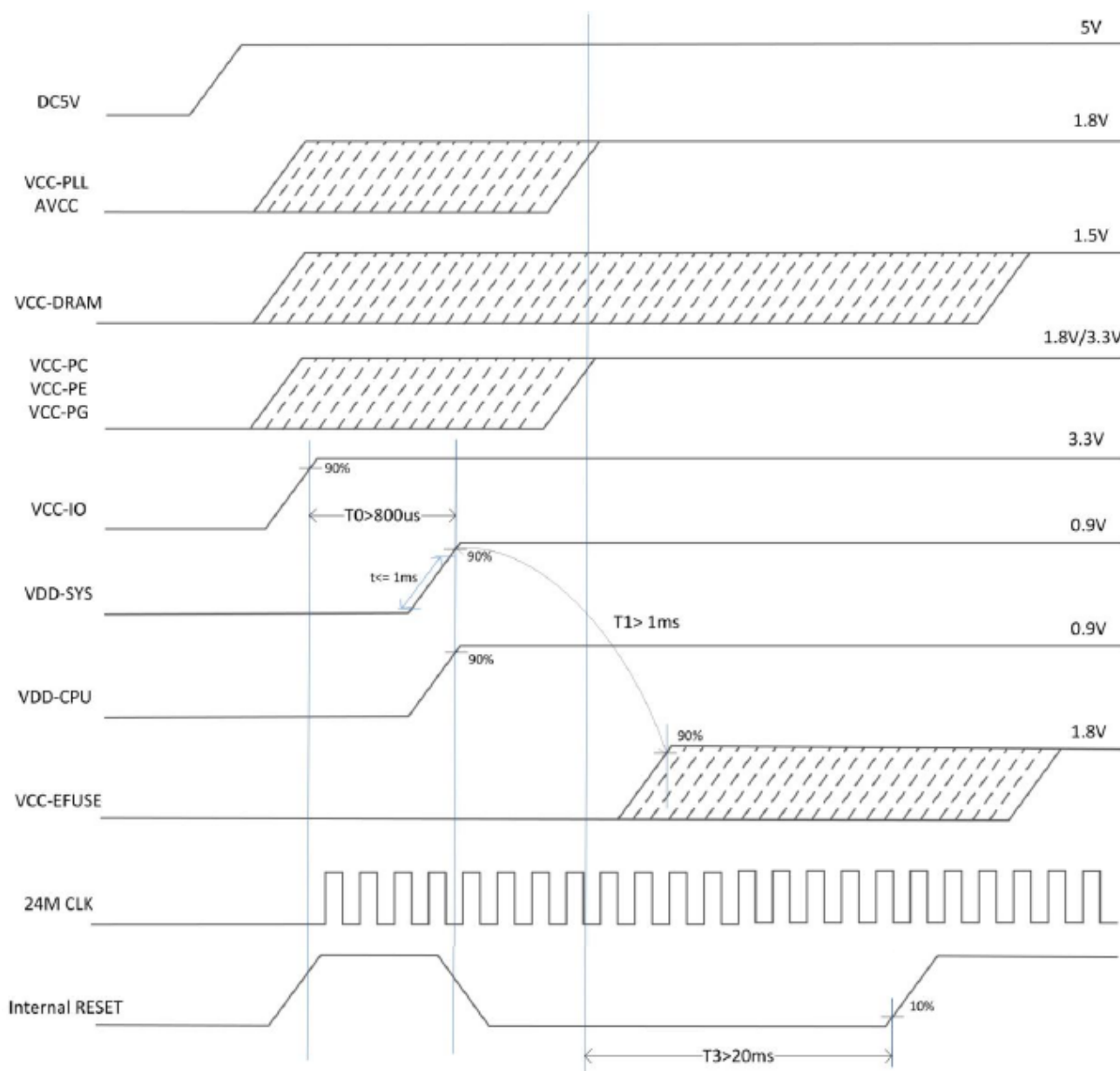

Figure 2- 15 Power on Sequence

2.6. USB OTG Port

Please follow the design rule below to populate the USB host interface:

Item	Parameter
Signal Group	USB
Topology	Differential Pair Point-to-Point
Reference Plane	Ground Referenced

Doc Title	Wireless Smart Audio Module-A97 Datasheet	Number	WMB20210203
		Version	0.4

Characteristic Trace Impedance (Zo)	90 Ω ±10%
Trace Width	4 mils
Serpentine Spacing (center to center)	8.5 mils
Minimum Isolation Spacing to Clock Signals	50 mils
Minimum Isolation Spacing to Low-Speed Signals	20 mils
Minimum Isolation Spacing to other USB Pair	20 mils
Total Length (with package length)	< 8000 mils
Maximum Recommended Via Count	2 (per side)
DM to DP Length Matching (with package length)	Match total length to within ±10 mils

Table 2- 3 A97 USB Design Rules

3. Software Introduction

3.1. Feature list

- “Easy Setup” to setup your network, with the help of one button of your device, you can connect the device to your home router quickly.
- Music stream protocol
Support Spotify Connect, Airplay, DLNA and QPlay protocol
- Amazon Alexa
- Music content
Support iHeartRadio, Napster/Rhapsody, Tidal, Deezer, vTune, Qobuz, Audible, Radio.de, NPR, Ximalaya, Qingting FM, QQ FM, Douban FM inside, with the help of App, you can search, stream, playback and preset the musics of the above music services.
- Multiroom
Support multiroom.
Support Airplay, Spotify, Bluetooth, Aux-in multiroom playback.
- Music format
HTTP/HTTPS/RTSP/MMS/TS protocol
HLS/ASX/M3U playlist format
MP3/AAC/FLAC/ALAC/WMA/APE/OGG codec
- BT
Support 5.2: A2DP, AVRCP, HFP, HID profiles
Support BLE
Support EDR
- Preset
With the help of App, you can store the music account token and playlist in the A97 series. Then the end user can play the playlist by the button/voice or timer even without the App.

Doc Title	Wireless Smart Audio Module-A97 Datasheet	Number	WMB20210203
		Version	0.4

3.2. APP support

- iOS App
≥ iOS6.1, suggest iOS10 and above
- Android APP
≥ Android 4.3.3
- Quick Customization
With the help of the Linkplay compile server, you can change the brand and some strings, change the logo and some pictures to get a customization App.

4. Module Environmental and Package

4.1. Environmental Ratings

The environmental ratings are shown as following table.

Characteristic	Min.	Units	Conditions/Comments
Operating Ambient Temperature	0 ~ 40	°C	
Storage Temperature	-5 ~ 45	°C	
Relative humidity	Less than 60	%	Storage
	Less than 80	%	Operation

Table 4-1 A97 Environmental Ratings

4.2. Electrostatic Discharge Specifications

Extreme caution must be exercised to prevent electrostatic discharge (ESD) damage. Proper use of wrist and heel grounding straps to discharge static electricity is required when handling these devices. Always store unused material in its antistatic packaging.

ESD Specifications

Type	Symbol	Condition	ESD Rating	Unit
ESD Handling	ESD_HAND_HBM	Human Body Model Contact Discharge per JEDEC EID/JESD22-A114	1000	V
Machine Model (MM)	ESD_HAND_MM	Machine Model Contact	30	V
CDM	ESD_HAND_CDM	Charged Device Model Contact Discharge per JEDEC EIA/JESD22-C101	300	V

Table 4-2 A97 ESD Specifications

Doc Title	Wireless Smart Audio Module-A97 Datasheet	Number	WMB20210203
		Version	0.4

CE Statement:

RF exposure information: The Maximum Permissible Exposure (MPE) level has been calculated based on a distance of d=20 cm between the device and the human body. To maintain compliance with RF exposure requirement, use product that maintain a 20cm distance between the device and human body.

Do not use the device in the environment at too high or too low temperature, never expose the device under strong sunshine or too wet environment. The suitable temperature for the product and accessories is 0°C-40°C.

The device for operation in the band 5150~5350 MHz is only for indoor use to reduce the potential for harmful interference to co-channel mobile satellite systems.

	AT	BE	BG	HR	CY	CZ	DK
	EE	FI	FR	DE	EL	HU	IE
	IT	LV	LT	LU	MT	NL	PL
	PT	RO	SK	SI	ES	SE	UK
	CH	IS	LI	NO	TR		

This product can be used across EU member states.

EU Regulatory Conformance

Hereby, Linkplay Technology Inc. Corporation declares that this device is in compliance with the essential requirements and other relevant provisions of Directive 2014/53/EU.



Doc Title	Wireless Smart Audio Module-A97 Datasheet	Number	WMB20210203
		Version	0.4

Federal Communication Commission (FCC) Radiation Exposure Statement

When using the product, maintain a distance of 20cm from the body to ensure compliance with RF exposure requirements.

FCC Statement:

This device complies with part 15 of the FCC rules. Operation is subject to the following two conditions:

- (1) this device may not cause harmful interference, and
- (2) this device must accept any interference received, including interference that may cause undesired operation.

NOTE: The manufacturer is not responsible for any radio or TV interference caused by unauthorized modifications or changes to this equipment. Such modifications or changes could void the user's authority to operate the equipment.

NOTE: This equipment has been tested and found to comply with the limits for a Class B digital device, pursuant to part 15 of the FCC Rules. These limits are designed to provide reasonable protection against harmful interference in a residential installation. This equipment generates uses and can radiate radio frequency energy and, if not installed and used in accordance with the instructions, may cause harmful interference to radio communications. However, there is no guarantee that interference will not occur in a particular installation. If this equipment does cause harmful interference to radio or television reception, which can be determined by turning the equipment off and on, the user is encouraged to try to correct the interference by one or more of the following measures:

- Reorient or relocate the receiving antenna.
- Increase the separation between the equipment and receiver.
- Connect the equipment into an outlet on a circuit different from that to which the receiver is connected.
- Consult the dealer or an experienced radio/TV technician for help.

This device is intended only for OEM integrators under the following conditions:

1. The antenna must be installed such that 20 cm is maintained between the antenna and users.
2. The transmitter module may not be co-located with any other transmitter or antenna. As long as the two conditions above are met, additional transmitter testing will not be required. However, the OEM integrator is still responsible for testing their end-product for any additional compliance requirements required for the installed module.

Important Note:

In the event that these conditions cannot be met (for example certain laptop configurations or co-location with another transmitter), then the Federal Communications Commission of the U.S. Government (FCC) and the Canadian Government authorizations are no longer considered valid and the FCC ID and IC ID cannot be used on the final product. In these circumstances, the OEM integrator shall be responsible for re-evaluating the end-product (including the transmitter) and obtaining a separate FCC and IC authorization in the U.S. and Canada.

Doc Title	Wireless Smart Audio Module-A97 Datasheet	Number	WMB20210203
		Version	0.4

OEM Integrators - End Product Labeling Considerations:

This transmitter module is authorized only for use in device where the antenna may be installed such that 20 cm may be maintained between the antenna and users. The final end product must be labeled in a visible area with the following: "Contains, FCC ID: 2ANOG-A97. The grantee's FCC ID can be used only when all FCC compliance requirements are met.

OEM Integrators - End Product Manual Provided to the End User:

The OEM integrator shall not provide information to the end user regarding how to install or remove this RF module in end product user manual. The end user manual must include all required regulatory information and warnings as outlined in this document.

Linkplay Confidential

EU Declaration of Conformity

Number

Wireless Smart Audio Module_A97_DOC

Name and address of the Manufacturer

Linkplay Technology Inc.

8F-8036, Qianren Building, No.7, Yingcui Road, Jiangning District, Nanjing, China

This declaration of conformity is issued under the sole responsibility of the manufacturer.

Object of the declaration

A97 is Wireless Smart Audio Module which incorporate WIFI,BT technologies.

The object of the declaration described above is in conformity with the relevant Union harmonisation legislation

Directive RED: 2014/53/EU

and other Union harmonization legislation where applicable:

RoHS directive: 2015/863/EU amending 2011/65/ EU

WEEE directive: 2012/19/EU

References to the relevant harmonised standards used or references to the other technical specifications in relation to which conformity is declared.

EN IEC 62368-1:2020+A11:2020;

ETSI EN 301 489-1 V2.2.3;

Draft ETSI EN 301 489-3 V2.1.2;

ETSI EN 301 489-17 V3.2.4;

ETSI EN 300 328 V2.2.2;

ETSI EN 301 893 V2.1.1;

ETSI EN 300 440 V2.2.1;

EN 62311:2020;

The Notified Body

Name: Phoenix Testlab

Number: 0700

Performed

Applicable Modules: B+C



And issued the EU-type examination certificate

Certificate number:

This product can be used across EU member state.

Description of accessories and components, including software, which allow the radio equipment to operate as intended and covered by the DoC

Hardware version	V01
Software version	Linkplay.4.4.235449
Antenna	External rod antenna

Software version note:Some software updates will be released by the manufacturer to fix some bug or enhance some function after placing on the market. All versions released by the manufacturer have been verified and still compliance with the related rules. All RF parameters (e.g.: frequency range, output power) are not accessible to the user, and can't be changed by the user.

Signed for and on behalf of:

Nanjing 13/09/2021

Place and date of issue

Cunxue Wang

cunxue wang, HW Manager

Name, Function, signature