

FCC CFR47 PART 22H, 24E, 27 CERTIFICATION TEST REPORT FCC ID: 2ANMU-WP5PRO

Product: Smart Phone
Trade Mark: OUKITEL
Model Number: WP5 Pro
Family Model: N/A
Report No.: S20060901604005

Prepared for

SHENZHEN YUNJI INTELLIGENT TECHNOLOGY CO.,LTD
A2 2F BUILDING ENET NEW INDUSTRIAL PARK, DAFU
INDUSTRIAL ZONE, GUANLAN, LONGHUA, SHENZHEN,
518XXX China

Prepared by

Shenzhen NTEK Testing Technology Co., Ltd.
1/F, Building E, Fenda Science Park, Sanwei Community, Xixiang Street
Bao'an District, Shenzhen 518126 P.R. China
Tel.: +86-755-6115 9388 Fax.: +86-755-6115 6599
Website: <http://www.ntek.org.cn>

TEST RESULT CERTIFICATION

Applicant's name : SHENZHEN YUNJI INTELLIGENT TECHNOLOGY CO.,LTD
Address..... : A2 2F BUILDING ENET NEW INDUSTRIAL PARK, DAFU INDUSTRIAL ZONE, GUANLAN, LONGHUA, SHENZHEN, 518XXX China

Manufacturer's Name..... : SHENZHEN YUNJI INTELLIGENT TECHNOLOGY CO.,LTD
Address..... : A2 2F BUILDING ENET NEW INDUSTRIAL PARK, DAFU INDUSTRIAL ZONE, GUANLAN, LONGHUA, SHENZHEN, 518XXX China

Product name..... : Smart Phone
Model and/or type reference .. : WP5 Pro
Family Model: N/A

Standards..... : FCC CFR 47 Part 22H, Part 24E, Part 27
Test procedure : ANSI C63.26:2015
ANSI/TIA-603-E-2016

This device described above has been tested by NTEK, and the test results show that the equipment under test (EUT) is in compliance with the FCC requirements. And it is applicable only to the tested sample identified in the report.

This report shall not be reproduced except in full, without the written approval of NTEK, this document may be altered or revised by NTEK, personal only, and shall be noted in the revision of the document.

Date of Test

Date (s) of performance of tests..... 09 Jun. 2020 ~ 24 Jun, 2020

Date of Issue 24 Jun, 2020

Test Result..... **Pass**

Testing Engineer : Allen Liu
(Allen Liu)

Technical Manager : Jason Chen
(Jason Chen)

Authorized Signatory : Sam Chen
(Sam Chen)

TABLE OF CONTENTS

1. GENERAL INFORMATION	6
1.1 PRODUCT DESCRIPTION	6
1.2 RELATED SUBMITTAL(S) / GRANT (S)	8
1.3 TEST METHODOLOGY	8
1.4 TEST FACILITY	8
MEASUREMENT UNCERTAINTY	8
1.5 SPECIAL ACCESSORIES.....	8
1.6 WORST-CASE CONFIGURATION AND MODE.....	8
1.6 SUMMARY OF TEST RESULTS	9
2. SYSTEM TEST CONFIGURATION	11
2.1 EUT CONFIGURATION.....	11
2.2 EUT EXERCISE	11
2.3 CONFIGURATION OF EUT SYSTEM.....	11
2.4 TEST SETUP	12
3. TEST AND MEASUREMENT EQUIPMENT	13
4. OUTPUT POWER	15
4.1 OUTPUT POWER MEASUREMENT	15
6. BANDEDGE AND EMISSION MASK	18
7. OUT OF BAND EMISSIONS	19
7.1 MEASUREMENT METHOD	20
8. RADIATED MEASUREMENT	21
8.1. RADIATED POWER (ERP & EIRP).....	21
8.2 LTE BAND 2.....	22
8.3 LTE BAND 4.....	26
8.4 LTE BAND 5.....	30

8.5 LTE BAND 7	32
8.6 LTE BAND 12	34
8.7 LTE BAND 17	36
9. SPURIOUS RADIATION EMISSION	38
9.1 LTE BAND 2	40
9.2 LTE BAND 4	42
9.3 LTE BAND 5	44
9.4 LTE BAND 7	46
9.5 LTE BAND 12	48
9.6 LTE BAND 17	50
10. FREQUENCY STABILITY	52
10.1 LTE BAND 2	53
10.2 LTE BAND 4	55
10.3 LTE BAND 5	57
10.4 LTE BAND 7	59
10.5 LTE BAND 12	61
10.6 LTE BAND 17	63
11. PEAK-TO-AVERAGE RATIO	65
11.1 Description of the PAR Measurement	65
11.2 Measuring Instruments	65
11.3 Test Procedures	65
11.4 Test Setup	65

1. GENERAL INFORMATION

1.1 PRODUCT DESCRIPTION

A major technical description of EUT is described as following:

Product Designation:	Smart Phone
Trade Mark	OUKITEL
Model Name	WP5 Pro
Family Model	N/A
Model Difference	N/A
FCC ID:	2ANMU-WP5PRO
Frequency Bands:	U.S. Bands: <input checked="" type="checkbox"/> LTE FDD Band 2,4,5,7,12,17
Frequency Range:	LTE FDD Band 2 Uplink: 1850MHz-1910MHz, Downlink: 1930MHz-1990MHz; LTE FDD Band 4 Uplink: 1710MHz-1755MHz, Downlink: 2110MHz-2155MHz; LTE FDD Band 5 Uplink: 824MHz-849MHz, Downlink: 869MHz-894MHz; LTE-FDD Band 7 Uplink: 2500MHz-2570MHz, Downlink: 2620MHz-2690MHz; LTE FDD Band 12 Uplink: 699MHz-716MHz, Downlink: 729MHz-746MHz; LTE FDD Band 17 Uplink: 704MHz-716MHz, Downlink: 734MHz-746MHz;
Type of Modulation:	QPSK/16QAM
SIM Card	SIM 1 and SIM 2 is a chipset unit and tested as a single chipset. The SIM 1 is chosen for test.
Antenna:	FPC Antenna
Antenna gain:	LTE FDD Band 2: 1.58dBi LTE FDD Band 4: 1.42dBi LTE FDD Band 5: -2.51dBi LTE FDD Band 7: 0.63dBi LTE FDD Band 12: -3.42dBi LTE FDD Band 17: -3.42dBi
Power Supply:	DC 3.85V, 8000mAh ,30.8Wh from Battery or DC 5V from Adapter
Adapter:	Model: HJ-0502000N2-US Input: 100-240V~50/60Hz 0.3A Output: 5.0V $\overline{\text{---}}$ 2.0A
Extreme Vol. Limits:	DC 3.4V to DC 4.4V (Nominal DC 3.85V) (Note 1)

HW Version	D937_MB_V1
SW Version	OUKITEL_WP5 Pro_EEA_V01_10112019
** Note1: The High Voltage DC 4.4V and Low Voltage 3.4V was declared by manufacturer, The EUT couldn't be operate normally with higher or lower voltage.	

1.2 RELATED SUBMITTAL(S) / GRANT (S)

This submittal(s) (test report) is intended for **FCC ID: 2ANMU-WP5PRO** filing to comply with the FCC Part 22H&24E &27.

1.3 TEST METHODOLOGY

The tests documented in this report were performed in accordance with ANSI/TIA-603-E-2016, FCC CFR 47 Part 2, Part 22, Part 24, Part 27, ANSI C63.26:2015.

1.4 TEST FACILITY

The test site used to collect the radiated data is located at:

ShenZhen NTEK Testing Technology Co., Ltd.

1/F, Building E, Fenda Science Park, Sanwei Community, Xixiang Street, Bao'an District, Shenzhen 518126 P.R.China.

The test site is constructed and calibrated to meet the FCC requirements in documents ANSI C63.26:2015& ANSI C63.4: 2014.

FCC Registration No.:463705

IC Registration No.:9270A-1,

CNAS Registration No.:L5516

MEASUREMENT UNCERTAINTY

The reported uncertainty of measurement, where expended uncertainty U is based on a standard uncertainty multiplied by a coverage factor of k=2, providing a level of confidence of approximately 95 %.

No.	Item	Uncertainty
1	Measuring Uncertainty for a Level of Confidence of 95% ($U = 2U_c(y)$)	2.5dB

1.5 SPECIAL ACCESSORIES

The battery and the charger, earphone supplied by the applicant were used as accessories and being tested with EUT intended for FCC grant together.

1.6 WORST-CASE CONFIGURATION AND MODE

The worst-case scenario for all measurements is based on the investigation results.

The device has LTE Bands of: Band 2, Band 4, Band 5, Band 7, Band 12, Band 17.

The RB Size was selected to measure for peak or average ERP and EIRP, which was based on the conducted power verification baseline data.

For the fundamental investigation of radiated emissions, the EUT is investigated for vertical and horizontal antenna orientations and X Y and Z orientations of the EUT alone. After the investigations the worst case was determined to be at X orientation for all LTE bands.

1.6 SUMMARY OF TEST RESULTS

FCC Part22, Subpart H/ FCC Part24, Subpart E, FCC Part27, Subpart L, KDB 971168 D01 Power Meas License Digital Systems v03			
FCC Rule	Test Item	Verdict	Remark
2.1046	Conducted Output Power	PASS	
22.913(d) 24.232(d) 27.50(d)(5) KDB 971168 D01 Clause 5.7	Peak-to-Average Ratio	PASS	
2.1049 22.917(b) 24.238(b) KDB 971168 D01 Clause 4.2	Occupied Bandwidth	PASS	
2.1051 22.917(a) 24.238(a) 27.53(c), (g), (h) KDB 971168 D01 Clause 6	Band Edge	PASS	
22.913(a)(2) 27.50(b)(10), (c)(10) KDB 971168 D01 Clause 5.6	Effective Radiated Power	PASS	
24.232(c) 27.50(h)(2), (d)(4) KDB 971168 D01 Clause 5.6	Equivalent Isotropic Radiated Power	PASS	
2.1053 22.917(a) 24.238(a) 27.53(c)(g)(h)(m) KDB 971168 D01 Clause 7	Field Strength of Spurious Radiation	PASS	
2.1055 22.355 24.235 27.54 KDB 971168 D01 Clause 9	Frequency Stability for Temperature & Voltage	PASS	

2.1051 22.917(a) 24.238(a) 27.53(c)(g)(h)(m) KDB 971168 D01 Clause 6	Conducted Emission	PASS	
--	--------------------	------	--

Remark:

1. "N/A" denotes test is not applicable in this Test Report.
2. All test items were verified and recorded according to the standards and without any deviation during the test.
3. No modifications are made to the EUT during all test items.

2. SYSTEM TEST CONFIGURATION

2.1 EUT CONFIGURATION

The EUT configuration for testing is installed on RF field strength measurement to meet the Commission's requirement and operating in a manner which intends to maximize its emission characteristics in a continuous normal application.

2.2 EUT EXERCISE

The Transmitter was operated in the maximum output power mode through Communication Tester. The TX frequency was fixed which was for the purpose of the measurements.

2.3 CONFIGURATION OF EUT SYSTEM

Table 2-1 Equipment Used in EUT System

Item	Equipment	Model No.	ID or Specification	Note
1	Smart Phone	WP5 Pro	FCC ID: 2ANMU-WP5PRO	EUT

*Note: All the accessories have been used during the test.
the following "EUT" in setup diagram means EUT system.*

2.4 TEST SETUP

For Radiated Test Cases



For Conducted Output Power

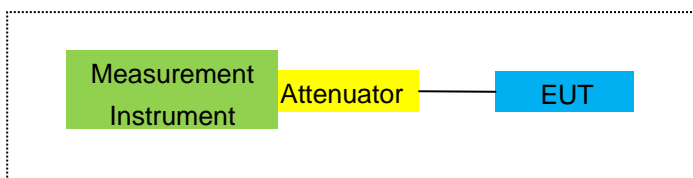

For Peak-to Average Ratio, Occupied Bandwidth, Conducted Band edge and Conducted Spurious Emission

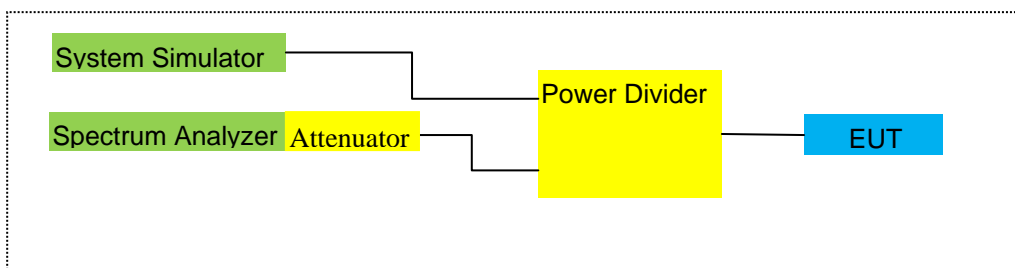

For Frequency Stability

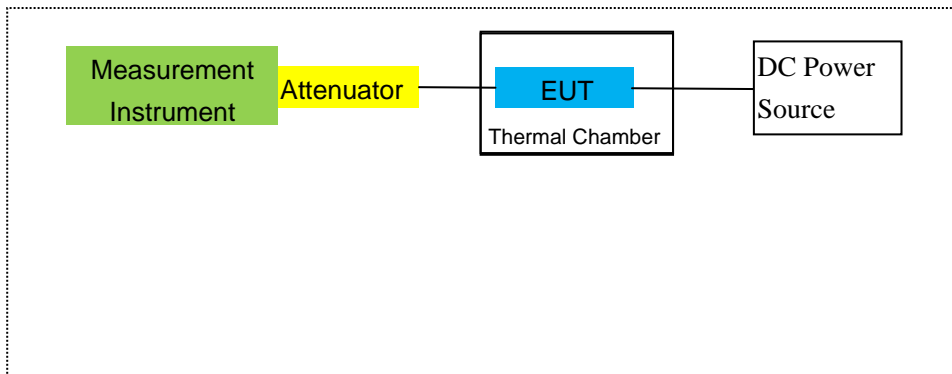

3. TEST AND MEASUREMENT EQUIPMENT

The following test and measurement equipment was utilized for the tests documented in this report:

Item	Kind of Equipment	Manufacturer	Type No.	Serial No.	Last calibration	Calibrated until	Calibration period
1	MXA Signal Analyzer	Agilent	N9020A	MY49100060	2019.08.28	2020.08.27	1 year
2	Test Receiver	R&S	ESPI	101318	2020.05.11	2021.05.10	1 year
3	Bilog Antenna	TESEQ	CBL6111D	31216	2020.04.11	2021.04.10	1 year
4	50Ω Coaxial Switch	Anritsu	MP59B	6200983705	2020.05.11	2023.05.10	3 year
5	Horn Antenna	EM	EM-AH-10180	2011071402	2020.04.11	2021.04.10	1 year
6	Horn Ant	Schwarzbeck	BBHA 9170	9170-181	2019.12.11	2020.12.10	1 year
7	Amplifier	EM	EM-30180	060538	2019.08.06	2020.08.05	1 year
8	Loop Antenna	ARA	PLA-1030/B	1029	2020.05.11	2021.05.10	1 year
9	Power Meter	R&S	NRVS	100696	2019.08.06	2020.08.05	1 year
10	Power Sensor	R&S	URV5-Z4	0395.1619.05	2020.05.11	2021.05.10	1 year
11	Test Cable	N/A	R-01	N/A	2019.08.06	2022.08.05	3 year
12	Test Cable	N/A	R-02	N/A	2019.08.06	2020.08.05	3 year
13	Test Cable	N/A	R-03	N/A	2019.06.28	2022.06.27	3 year
14	Test Receiver	R&S	ESCI	101160	2020.05.11	2021.05.10	1 year
15	LISN	R&S	ENV216	101313	2020.05.11	2021.05.10	1 year
16	LISN	EMCO	3816/2	00042990	2020.05.11	2021.05.10	1 year
17	50Ω Coaxial Switch	Anritsu	MP59B	6200264417	2020.05.11	2021.05.10	1 year
18	Passive Voltage Probe	R&S	ESH2-Z3	100196	2020.04.11	2021.04.10	3 year
19	Test Cable	N/A	C01	N/A	2020.05.11	2023.05.10	3 year
20	Test Cable	N/A	C02	N/A	2020.05.11	2023.05.10	3 year
21	Test Cable	N/A	C03	N/A	2020.05.11	2021.05.10	1 year
22	Attenuator	MCE	24-10-34	BN9258	2020.05.11	2021.05.10	1 year
23	Spectrum Analyzer	agilent	e4440a	us44300399	2020.05.11	2021.05.10	1 year
24	test receiver	R&S	ESCI	a0304218	2020.05.11	2021.05.10	1 year
25	Communication Tester	R&S	CMU200	A0304247	2019.08.06	2020.08.05	1 year
27	DC Power Source	N/A	PS-6005D	20170402923	2018.06.06	2021.06.05	3 year

28	PSG Analog Signal Generator	Agilent	E8257D	MY51110112	2019.08.06	2020.08.05	1 year
29	Communication Tester	R&S	CMW500	148500	2020.05.11	2021.05.10	1 year

Note: Each piece of equipment is scheduled for calibration once a year except the Test Cable& DC Power Source which is scheduled for calibration every 3 years.

4. OUTPUT POWER

4.1 OUTPUT POWER MEASUREMENT

LTE Measurement Procedure:

All LTE bands conducted power peak and average are obtained from the CMW500 telecommunication test set. The following tests were conducted according to the test requirements outlined in section 6.2 of the 3GPP TS36.101 specification.

UE Power Class: 3 (23 +/- 2dBm). The allowed Maximum Power Reduction (MPR) for the maximum output power due to higher order modulation and transmit bandwidth configuration (resource blocks) is specified in Table 6.2.3-1 of the 3GPP TS36.101.

Table 6.2.3-1: Maximum Power Reduction (MPR) for Power Class 3

Modulation	Channel bandwidth / Transmission bandwidth (RB)						MPR (dB)
	1.4 MHz	3.0 MHz	5 MHz	10 MHz	15 MHz	20 MHz	
QPSK	> 5	> 4	> 8	> 12	> 16	> 18	≤ 1
16 QAM	≤ 5	≤ 4	≤ 8	≤ 12	≤ 16	≤ 18	≤ 1
16 QAM	> 5	> 4	> 8	> 12	> 16	> 18	≤ 2

The allowed A-MPR values specified below in Table 6.2.4.-1 of 3GPP TS36.101 are in addition to the allowed MPR requirements. All the measurements below were performed with A-MPR disabled, by using Network Signaling Value of "NS_01".3

Table 6.2.4-1: Additional Maximum Power Reduction (A-MPR)

Network Signalling value	Requirements (sub-clause)	E-UTRA Band	Channel bandwidth (MHz)	Resources Blocks (N_{RB})	A-MPR (dB)
NS_01	6.6.2.1.1	Table 5.5-1	1.4, 3, 5, 10, 15, 20	Table 5.6-1	NA
NS_03	6.6.2.2.1	2, 4, 10, 23, 25, 35, 36	3	>5	≤ 1
			5	>6	≤ 1
			10	>6	≤ 1
			15	>8	≤ 1
			20	>10	≤ 1
NS_04	6.6.2.2.2	41	5	>6	≤ 1
			10, 15, 20	See Table 6.2.4-4	
NS_05	6.6.3.3.1	1	10, 15, 20	≥ 50	≤ 1
NS_06	6.6.2.2.3	12, 13, 14, 17	1.4, 3, 5, 10	Table 5.6-1	n/a
NS_07	6.6.2.2.3	13	10	Table 6.2.4-2	Table 6.2.4-2
	6.6.3.3.2				
NS_08	6.6.3.3.3	19	10, 15	> 44	≤ 3
NS_09	6.6.3.3.4	21	10, 15	> 40	≤ 1
				> 55	≤ 2
NS_10		20	15, 20	Table 6.2.4-3	Table 6.2.4-3
NS_11	6.6.2.2.1	23 ¹	1.4, 3, 5, 10	Table 6.2.4-5	Table 6.2.4-5
..					
NS_32	-	-	-	-	-

Note 1: Applies to the lower block of Band 23, i.e. a carrier placed in the 2000-2010 MHz region.

Test data reference attachment.

5. OCCUPIED BANDWIDTH

RULE PART(S)

FCC: §2.1049

LIMITS

For reporting purposes only

TEST PROCEDURE

The transmitter output was connected to a calibrated coaxial cable and coupler, the other end of which was connected to a spectrum analyzer. The occupied bandwidth was measured with the spectrum analyzer at the low, middle and high channel in each band. The -26dB bandwidth was also measured and recorded.

MODES TESTED

- LTE Band 2
- LTE Band 4
- LTE Band 5
- LTE Band 7
- LTE Band 12
- LTE Band 17

RESULTS

PASS

Test data reference attachment.

6. BANDEDGE AND EMISSION MASK

RULE PART(S)

FCC: §2.1051, §22.917(a), §24.238(a), §27.53(c)(g)(h)(m)

FCC: §2.1046, §22.913, §24.232

LIMITS

The minimum permissible attenuation level of any spurious emission is $43 + \log_{10}(P[\text{Watts}])$, where P is the transmitter power in Watts.

The minimum permissible attenuation level for Band 7 is as following.

Per 27.53(g) for operations in the 698-746 MHz band, in the 100 kHz bands immediately outside and adjacent to the frequency block a resolution bandwidth of at least 30 kHz may be employed to demonstrate compliance with the out-of-band emissions limit.

Per 27.53(c.5) for operations in the 776-788 MHz band, in the 100 kHz bands immediately outside and adjacent to the frequency block a resolution bandwidth of at least 30 kHz may be employed to demonstrate compliance with the out-of-band emissions limit.

For all plots showing emissions in the 763 – 775MHz and 793 – 805MHz band, the FCC limit per 27.53(c.4) is $65 + 10\log_{10}(P) = -35\text{dBm}$ in a 6.25kHz bandwidth.

Per 27.53(m) for operations in the BRS/EBS bands, the attenuation factor shall be not less than $40 + 10 \log (P)$ dB on all frequencies between the channel edge and 5 megahertz from the channel edge, $43 + 10 \log (P)$ dB on all frequencies between 5 megahertz and X megahertz from the channel edge, and $55 + 10 \log (P)$ dB on all frequencies more than X megahertz from the channel edge, where X is the greater of 6 megahertz or the actual emission bandwidth.

TEST PROCEDURE

The transmitter output was connected to a CMW500 Test Set and configured to operate at maximum power. The band edge emissions were measured at the required operating frequencies in each band on the Spectrum Analyzer.

For each band edge measurement:

Set the spectrum analyzer span to include the block edge frequency

Set a marker to point the corresponding band edge frequency in each test case.

Set display line

Set resolution bandwidth to at least 1% of emission bandwidth.

MODES TESTED

- LTE Band 2/4/5/7/12/17

RESULTS

Test data reference attachment.

7. OUT OF BAND EMISSIONS

RULE PART(S)

FCC: §2.1051, §22.917(a), §24.238(a), §27.53(c)(g)(h)(m)

LIMITS

The minimum permissible attenuation level of any spurious emission is $43 + \log_{10}(P[\text{Watts}])$, where P is the transmitter power in Watts.

The minimum permissible attenuation level for Band 7 is as following.

Per 27.53(g) for operations in the 698-746 MHz band, in the 100 kHz bands immediately outside and adjacent to the frequency block a resolution bandwidth of at least 30 kHz may be employed to demonstrate compliance with the out-of-band emissions limit.

Per 27.53(c.5) for operations in the 776-788 MHz band, in the 100 kHz bands immediately outside and adjacent to the frequency block a resolution bandwidth of at least 30 kHz may be employed to demonstrate compliance with the out-of-band emissions limit.

For all plots showing emissions in the 763 – 775MHz and 793 – 805MHz band, the FCC limit per 27.53(c.4) is $65 + 10\log_{10}(P) = -35\text{dBm}$ in a 6.25kHz bandwidth.

Per 27.53(m) for operations in the BRS/EBS bands, the attenuation factor shall be not less than $40 + 10 \log (P)$ dB on all frequencies between the channel edge and 5 megahertz from the channel edge, $43 + 10 \log (P)$ dB on all frequencies between 5 megahertz and X megahertz from the channel edge, and $55 + 10 \log (P)$ dB on all frequencies more than X megahertz from the channel edge, where X is the greater of 6 megahertz or the actual emission bandwidth.

TEST PROCEDURE

The RF output of the transmitter was connected to a spectrum analyzer through a calibrated coaxial cable. Sufficient scans were taken to show the out-of-band Emissions, if any, up to 10th harmonic. Multiple sweeps were recorded in maximum hold mode using a peak detector to ensure that the worst-case emissions were caught.

For each out of band emissions measurement:

- Set display line
- Set RBW & VBW to 100 kHz for the measurement below 1 GHz, and 1 MHz for the measurement above 1 GHz.

MODES TESTED

- LTE Band 2
- LTE Band 4
- LTE Band 5
- LTE Band 7
- LTE Band 12
- LTE Band 17

7.1 MEASUREMENT METHOD

The test set up and general procedure is similar to conducted peak output power test. Only different for setting the measurement configuration of the measuring instrument of Spectrum Analyzer.

Test data reference attachment.

8. RADIATED MEASUREMENT

8.1. RADIATED POWER (ERP & EIRP)

RULE PART(S)

FCC: §2.1046, §22.913(a)(2), §24.232(c) and §27.50 (h)(2), (b)(10), (c)(10), (d)(4)

LIMITS:

22.913(a) (2)- The ERP of mobile transmitters and auxiliary test transmitters must not exceed 7 Watts.
24.232 (c) Mobile and portable stations are limited to 2 watts EIRP.
27.50 (c) (10) the following power and antenna height requirements apply to stations transmitting in the 698–746 MHz band, the portable stations (hand-held devices) are limited to 3 watts ERP.
27.50 (b)(10) Portable stations (hand-held devices) transmitting in the 746–757 MHz, 758–763 MHz, 776–793 MHz, and 805–806 MHz bands are limited to 3 watts ERP.
27.50 (d)(4) The following power and antenna height requirements apply to stations transmitting in the 1710–1755 MHz and 2110–2155 MHz bands: Fixed, mobile, and portable (hand-held) stations operating in the 1710–1755 MHz band are limited to 1 watt EIRP.
27.50 (h)(2) Mobile and other user stations in the 2500–2570 MHz and 2620–2690 MHz bands. Mobile stations are limited to 2.0 watts EIRP. All user stations are limited to 2.0 watts transmitter output power.

TEST PROCEDURE

ANSI/TIA-603-E Clause 2.2.17

KDB 971168 v02r01 RF power output using broadband peak and average power meter method.

KDB 971168 D01 Power Meas License Digital Systems v02r01, "Measurement Guidance for Certification of Licensed Digital Transmitters"

MODES TESTED

- LTE Band 2
- LTE Band 4
- LTE Band 5
- LTE Band 7
- LTE Band 12
- LTE Band 17

RESULTS

Pass

8.2 LTE BAND 2

Radiated Power (EIRP) for Band 2										
Mode	RB/RB SIZE	Frequency	Result						Polarization Of Max. ERP	Conclusion
			SG Level (dBm)	Cable Loss (dBm)	Antenna Gain (dB)	Max. EIRP Average (dBm)	Max. EIRP Average (mW)			
1.4MHz Band QPSK	1/#Midd	1850.7	-2.15	3.76	28.24	22.33	171.00	Horizontal	Pass	
		1880	-1.22	3.91	28.22	23.09	203.70	Horizontal	Pass	
		1909.3	-1.91	3.93	28.20	22.36	172.19	Horizontal	Pass	
3.0MHz Band QPSK	1/#Midd	1851.5	-1.51	3.77	28.23	22.95	197.24	Horizontal	Pass	
		1880	-2.43	3.91	28.24	21.90	154.88	Horizontal	Pass	
		1908.5	-1.68	3.94	28.25	22.63	183.23	Horizontal	Pass	
5.0MHz Band QPSK	1/#Midd	1852.5	-2.13	3.77	28.31	22.41	174.18	Horizontal	Pass	
		1880	-1.52	3.91	28.22	22.79	190.11	Horizontal	Pass	
		1907.5	-1.81	3.94	28.20	22.45	175.79	Horizontal	Pass	
10.0MHz Band QPSK	1/#Midd	1855	-2.34	3.79	28.33	22.20	166.05	Horizontal	Pass	
		1880	-1.05	3.95	28.22	23.22	209.67	Horizontal	Pass	
		1905	-1.69	3.97	28.19	22.53	179.02	Horizontal	Pass	
15.0MHz Band QPSK	1/#Midd	1857.5	-1.88	3.79	28.34	22.67	184.96	Horizontal	Pass	
		1880	-1.71	3.95	28.22	22.56	180.50	Horizontal	Pass	
		1902.5	-1.73	3.97	28.18	22.48	176.98	Horizontal	Pass	
20.0MHz Band QPSK	1/#Midd	1860	-2.73	3.81	28.35	21.81	151.64	Horizontal	Pass	
		1880	-2.10	3.96	28.22	22.16	164.56	Horizontal	Pass	
		1900	-1.98	4.00	28.16	22.18	165.08	Horizontal	Pass	
1.4MHz Band QPSK	1/#Midd	1850.7	-2.19	3.76	28.24	22.29	169.29	Vertical	Pass	
		1880	-1.70	3.91	28.22	22.61	182.44	Vertical	Pass	
		1909.3	-0.90	3.93	28.20	23.37	217.08	Vertical	Pass	
3.0MHz Band QPSK	1/#Midd	1851.5	-1.41	3.77	28.23	23.05	201.66	Vertical	Pass	
		1880	-1.07	3.91	28.24	23.26	211.94	Vertical	Pass	
		1908.5	-1.58	3.94	28.25	22.73	187.30	Vertical	Pass	
5.0MHz Band QPSK	1/#Midd	1852.5	-1.46	3.77	28.31	23.08	203.10	Vertical	Pass	
		1880	-1.86	3.91	28.22	22.45	175.70	Vertical	Pass	
		1907.5	-1.63	3.94	28.20	22.63	183.33	Vertical	Pass	
10.0MHz Band	1/#Midd	1855	-1.73	3.79	28.33	22.81	190.90	Vertical	Pass	
		1880	-1.82	3.95	28.22	22.45	175.93	Vertical	Pass	

QPSK		1905	-1.17	3.97	28.19	23.05	201.82	Vertical	Pass
15.0MHz Band QPSK	1/#Midd	1857.5	-2.38	3.79	28.34	22.17	165.00	Vertical	Pass
		1880	-1.26	3.95	28.22	23.01	199.90	Vertical	Pass
		1902.5	-1.27	3.97	28.18	22.94	196.74	Vertical	Pass
20.0MHz Band QPSK	1/#Midd	1860	-2.15	3.81	28.35	22.39	173.38	Vertical	Pass
		1880	-1.28	3.96	28.22	22.98	198.61	Vertical	Pass
		1900	-0.79	4.00	28.16	23.37	217.27	Vertical	Pass

Note:

SG Level= Signal generator output

Max. EIRP Average (dBm)= Antenna Gain(dB)+ SG Level (dBm)- Cable Loss(dBm)

Radiated Power (EIRP) for Band 2									
Mode	RB/RB SIZE	Frequency	Result					Polarization Of Max. ERP	Conclusion
			SG Level (dBm)	Cable Loss (dBm)	Antenna Gain (dB)	Max. EIRP Average (dBm)	Max. EIRP		
							Average (mW)		
1.4MHz Band 16 QAM	1/#Midd	1850.7	-1.60	3.76	28.24	22.88	194.25	Horizontal	Pass
		1880	-0.94	3.91	28.22	23.37	217.27	Horizontal	Pass
		1909.3	-1.17	3.93	28.20	23.10	204.40	Horizontal	Pass
3.0MHz Band 16 QAM	1/#Midd	1851.5	-1.58	3.77	28.23	22.88	194.24	Horizontal	Pass
		1880	-2.07	3.91	28.24	22.26	168.16	Horizontal	Pass
		1908.5	-2.14	3.94	28.25	22.17	164.82	Horizontal	Pass
5.0MHz Band 16 QAM	1/#Midd	1852.5	-1.88	3.77	28.31	22.66	184.50	Horizontal	Pass
		1880	-2.02	3.91	28.22	22.29	169.43	Horizontal	Pass
		1907.5	-1.59	3.94	28.20	22.67	184.93	Horizontal	Pass
10.0MHz Band 16 QAM	1/#Midd	1855	-2.57	3.79	28.33	21.97	157.40	Horizontal	Pass
		1880	-1.85	3.95	28.22	22.42	174.58	Horizontal	Pass
		1905	-0.89	3.97	28.19	23.33	215.28	Horizontal	Pass
15.0MHz Band 16 QAM	1/#Midd	1857.5	-2.16	3.79	28.34	22.39	173.21	Horizontal	Pass
		1880	-1.72	3.95	28.22	22.55	179.96	Horizontal	Pass
		1902.5	-1.16	3.97	28.18	23.05	201.91	Horizontal	Pass
20.0MHz Band 16 QAM	1/#Midd	1860	-3.16	3.81	28.35	21.38	137.49	Horizontal	Pass
		1880	-1.40	3.96	28.22	22.86	193.23	Horizontal	Pass
		1900	-2.31	4.00	28.16	21.85	153.26	Horizontal	Pass
1.4MHz Band 16 QAM	1/#Midd	1850.7	-2.51	3.76	28.24	21.97	157.49	Vertical	Pass
		1880	-1.40	3.91	28.22	22.91	195.25	Vertical	Pass
		1909.3	-0.91	3.93	28.20	23.36	216.79	Vertical	Pass
3.0MHz Band 16 QAM	1/#Midd	1851.5	-1.65	3.77	28.23	22.81	191.19	Vertical	Pass
		1880	-1.07	3.91	28.24	23.26	211.81	Vertical	Pass
		1908.5	-1.35	3.94	28.25	22.96	197.66	Vertical	Pass
5.0MHz Band 16 QAM	1/#Midd	1852.5	-1.69	3.77	28.31	22.85	192.65	Vertical	Pass
		1880	-1.71	3.91	28.22	22.60	181.93	Vertical	Pass
		1907.5	-1.79	3.94	28.20	22.47	176.79	Vertical	Pass
10.0MHz Band 16 QAM	1/#Midd	1855	-2.08	3.79	28.33	22.46	176.20	Vertical	Pass
		1880	-2.35	3.95	28.22	21.92	155.53	Vertical	Pass
		1905	-1.23	3.97	28.19	22.99	198.88	Vertical	Pass
15.0MHz Band	1/#Midd	1857.5	-2.56	3.79	28.34	21.99	158.18	Vertical	Pass
		1880	-1.15	3.95	28.22	23.12	205.15	Vertical	Pass

16 QAM		1902.5	-0.83	3.97	28.18	23.38	217.77	Vertical	Pass
20.0MHz Band 16 QAM	1/#Midd	1860	-2.77	3.81	28.35	21.77	150.18	Vertical	Pass
		1880	-0.83	3.96	28.22	23.43	220.23	Vertical	Pass
		1900	-1.34	4.00	28.16	22.82	191.61	Vertical	Pass

Note:

SG Level= Signal generator output

Max. EIRP Average (dBm)= Antenna Gain(dB)+ SG Level (dBm)- Cable Loss(dBm)

8.3 LTE BAND 4

Radiated Power (EIRP) for Band 4										
Mode	RB/RB SIZE	Frequency	Result						Polarization Of Max. ERP	Conclusion
			SG Level (dBm)	Cable Loss (dBm)	Antenna Gain (dB)	Max. EIRP Average (dBm)	Max. EIRP Average (mW)			
			1.4MHz Band QPSK	1/#Midd	1710.7	-2.53	3.12	27.58		
		1732.5	-1.46	3.27	27.61	22.88	193.92	Horizontal	Pass	
		1754.3	-2.72	3.29	27.63	21.62	145.08	Horizontal	Pass	
3.0MHz Band QPSK	1/#Midd	1711.5	-3.18	3.13	27.61	21.30	134.99	Horizontal	Pass	
		1732.5	-2.04	3.27	27.61	22.30	170.00	Horizontal	Pass	
		1753.5	-2.17	3.30	27.62	22.15	164.06	Horizontal	Pass	
5.0MHz Band QPSK	1/#Midd	1712.5	-2.78	3.13	27.63	21.72	148.53	Horizontal	Pass	
		1732.5	-2.16	3.27	27.61	22.18	165.02	Horizontal	Pass	
		1752.5	-2.91	3.30	27.60	21.39	137.80	Horizontal	Pass	
10.0MHz Band QPSK	1/#Midd	1715	-3.13	3.15	27.64	21.36	136.68	Horizontal	Pass	
		1732.5	-2.70	3.31	27.61	21.60	144.50	Horizontal	Pass	
		1750	-2.36	3.33	27.59	21.90	154.71	Horizontal	Pass	
15.0MHz Band QPSK	1/#Midd	1717.5	-3.49	3.15	27.65	21.01	126.07	Horizontal	Pass	
		1732.5	-2.68	3.31	27.61	21.62	145.36	Horizontal	Pass	
		1747.5	-2.49	3.33	27.57	21.75	149.48	Horizontal	Pass	
20.0MHz Band QPSK	1/#Midd	1720	-4.24	3.17	27.66	20.25	106.00	Horizontal	Pass	
		1732.5	-1.77	3.32	27.61	22.52	178.47	Horizontal	Pass	
		1745	-2.82	3.36	27.56	21.38	137.25	Horizontal	Pass	
1.4MHz Band QPSK	1/#Midd	1710.7	-2.51	3.12	27.58	21.95	156.71	Vertical	Pass	
		1732.5	-1.84	3.27	27.61	22.50	178.00	Vertical	Pass	
		1754.3	-2.82	3.29	27.63	21.52	141.86	Vertical	Pass	
3.0MHz Band QPSK	1/#Midd	1711.5	-2.90	3.13	27.61	21.58	143.96	Vertical	Pass	
		1732.5	-2.57	3.27	27.61	21.77	150.43	Vertical	Pass	
		1753.5	-2.52	3.30	27.62	21.80	151.22	Vertical	Pass	
5.0MHz Band QPSK	1/#Midd	1712.5	-2.77	3.13	27.63	21.73	149.01	Vertical	Pass	
		1732.5	-2.01	3.27	27.61	22.33	171.15	Vertical	Pass	
		1752.5	-1.67	3.30	27.60	22.63	183.33	Vertical	Pass	
10.0MHz Band	1/#Midd	1715	-2.18	3.15	27.64	22.31	170.35	Vertical	Pass	
		1732.5	-2.90	3.31	27.61	21.40	137.93	Vertical	Pass	

QPSK		1750	-2.23	3.33	27.59	22.03	159.42	Vertical	Pass
15.0MHz Band QPSK	1/#Midd	1717.5	-3.13	3.15	27.65	21.37	136.93	Vertical	Pass
		1732.5	-2.49	3.31	27.61	21.81	151.67	Vertical	Pass
		1747.5	-2.70	3.33	27.57	21.54	142.60	Vertical	Pass
20.0MHz Band QPSK	1/#Midd	1720	-2.16	3.17	27.66	22.33	171.15	Vertical	Pass
		1732.5	-1.38	3.32	27.61	22.91	195.24	Vertical	Pass
		1745	-2.06	3.36	27.56	22.14	163.63	Vertical	Pass

Note:

SG Level= Signal generator output

Max. EIRP Average (dBm)= Antenna Gain(dB)+ SG Level (dBm)- Cable Loss(dBm)

Radiated Power (EIRP) for Band 4									
Mode	RB/RB SIZE	Frequency	Result						Conclusion
			SG Level (dBm)	Cable Loss (dBm)	Antenna Gain (dB)	Max. EIRP	Max. EIRP	Polarization Of Max. ERP	
						Average (dBm)	Average (mW)		
1.4MHz Band 16 QAM	1/#Midd	1710.7	-2.32	3.12	27.58	22.14	163.70	Horizontal	Pass
		1732.5	-2.27	3.27	27.61	22.07	160.97	Horizontal	Pass
		1754.3	-3.68	3.29	27.63	20.66	116.48	Horizontal	Pass
3.0MHz Band 16 QAM	1/#Midd	1711.5	-3.88	3.13	27.61	20.60	114.94	Horizontal	Pass
		1732.5	-2.35	3.27	27.61	21.99	158.14	Horizontal	Pass
		1753.5	-2.67	3.30	27.62	21.65	146.34	Horizontal	Pass
5.0MHz Band 16 QAM	1/#Midd	1712.5	-2.88	3.13	27.63	21.62	145.36	Horizontal	Pass
		1732.5	-3.07	3.27	27.61	21.27	134.02	Horizontal	Pass
		1752.5	-3.23	3.30	27.60	21.07	127.86	Horizontal	Pass
10.0MHz Band 16 QAM	1/#Midd	1715	-2.73	3.15	27.64	21.76	149.80	Horizontal	Pass
		1732.5	-2.49	3.31	27.61	21.81	151.78	Horizontal	Pass
		1750	-2.26	3.33	27.59	22.00	158.54	Horizontal	Pass
15.0MHz Band 16 QAM	1/#Midd	1717.5	-3.24	3.15	27.65	21.26	133.81	Horizontal	Pass
		1732.5	-2.27	3.31	27.61	22.03	159.50	Horizontal	Pass
		1747.5	-3.44	3.33	27.57	20.80	120.34	Horizontal	Pass
20.0MHz Band 16 QAM	1/#Midd	1720	-5.24	3.17	27.66	19.25	84.22	Horizontal	Pass
		1732.5	-2.83	3.32	27.61	21.46	139.89	Horizontal	Pass
		1745	-3.01	3.36	27.56	21.19	131.37	Horizontal	Pass
1.4MHz Band 16 QAM	1/#Midd	1710.7	-2.68	3.12	27.58	21.78	150.69	Vertical	Pass
		1732.5	-2.84	3.27	27.61	21.50	141.37	Vertical	Pass
		1754.3	-2.62	3.29	27.63	21.72	148.55	Vertical	Pass
3.0MHz Band 16 QAM	1/#Midd	1711.5	-1.70	3.13	27.61	22.78	189.82	Vertical	Pass
		1732.5	-1.51	3.27	27.61	22.83	191.95	Vertical	Pass
		1753.5	-1.85	3.30	27.62	22.47	176.66	Vertical	Pass
5.0MHz Band 16 QAM	1/#Midd	1712.5	-2.70	3.13	27.63	21.80	151.36	Vertical	Pass
		1732.5	-3.06	3.27	27.61	21.28	134.23	Vertical	Pass
		1752.5	-2.47	3.30	27.60	21.83	152.46	Vertical	Pass
10.0MHz Band 16 QAM	1/#Midd	1715	-2.27	3.15	27.64	22.22	166.64	Vertical	Pass
		1732.5	-2.90	3.31	27.61	21.40	138.04	Vertical	Pass
		1750	-2.94	3.33	27.59	21.32	135.37	Vertical	Pass
15.0MHz Band	1/#Midd	1717.5	-3.77	3.15	27.65	20.73	118.31	Vertical	Pass
		1732.5	-2.72	3.31	27.61	21.58	143.81	Vertical	Pass

16 QAM		1747.5	-1.51	3.33	27.57	22.73	187.47	Vertical	Pass
20.0MHz Band 16 QAM	1/#Midd	1720	-2.30	3.17	27.66	22.19	165.51	Vertical	Pass
		1732.5	-1.90	3.32	27.61	22.39	173.49	Vertical	Pass
		1745	-1.21	3.36	27.56	22.99	199.07	Vertical	Pass

Note:

SG Level= Signal generator output

Max. EIRP Average (dBm)= Antenna Gain(dB)+ SG Level (dBm)- Cable Loss(dBm)

8.4 LTE BAND 5

Radiated Power (ERP) for Band 5											
Mode	RB/ RB SIZE	Freque ncy	Result							Polarizati on Of Max. ERP	Conclu sion
			SG Level	Cable Loss (dBm)	Anten na Gain (dB)	Corre ction (dB)	Max. ERP	Max. ERP			
			(dBm)				Averag e	Averag e			
							(dBm)	(mW)			
1.4MHz Band QPSK	1/#M id	824.7	6.78	2.01	19.68	2.15	22.30	169.92	Horizontal	Pass	
		836.5	5.65	2.01	19.77	2.15	21.26	133.67	Horizontal	Pass	
		848.3	6.65	2.02	19.82	2.15	22.30	169.68	Horizontal	Pass	
3.0MHz Band QPSK	1/#M id	825.5	6.11	2.01	19.70	2.15	21.65	146.22	Horizontal	Pass	
		836.5	5.80	2.01	19.77	2.15	21.41	138.33	Horizontal	Pass	
		847.5	6.52	2.02	19.81	2.15	22.16	164.53	Horizontal	Pass	
5.0MHz Band QPSK	1/#M id	826.5	6.16	2.01	19.71	2.15	21.71	148.08	Horizontal	Pass	
		836.5	5.26	2.01	19.77	2.15	20.87	122.28	Horizontal	Pass	
		846.5	6.49	2.02	19.79	2.15	22.11	162.69	Horizontal	Pass	
10.0MH z Band QPSK	1/#M id	829	6.03	2.01	19.73	2.15	21.60	144.48	Horizontal	Pass	
		836.5	6.02	2.01	19.77	2.15	21.63	145.70	Horizontal	Pass	
		844	5.95	2.02	19.78	2.15	21.56	143.10	Horizontal	Pass	
1.4MHz Band QPSK	1/#M id	824.7	7.01	2.01	19.68	2.15	22.53	179.11	Vertical	Pass	
		836.5	6.79	2.01	19.77	2.15	22.40	173.96	Vertical	Pass	
		848.3	6.95	2.02	19.82	2.15	22.60	182.11	Vertical	Pass	
3.0MHz Band QPSK	1/#M id	825.5	6.52	2.01	19.70	2.15	22.06	160.76	Vertical	Pass	
		836.5	6.89	2.01	19.77	2.15	22.50	177.84	Vertical	Pass	
		847.5	6.60	2.02	19.81	2.15	22.24	167.35	Vertical	Pass	
5.0MHz Band QPSK	1/#M id	826.5	6.13	2.01	19.71	2.15	21.68	147.23	Vertical	Pass	
		836.5	7.14	2.01	19.77	2.15	22.75	188.32	Vertical	Pass	
		846.5	6.31	2.02	19.79	2.15	21.93	155.91	Vertical	Pass	
10.0MH z Band QPSK	1/#M id	829	6.02	2.01	19.73	2.15	21.59	144.31	Vertical	Pass	
		836.5	6.86	2.01	19.77	2.15	22.47	176.57	Vertical	Pass	
		844	7.48	2.02	19.78	2.15	23.09	203.48	Vertical	Pass	

Note:

SG Level= Signal generator output

Max. EIRP Average (dBm)= Antenna Gain(dB)+ SG Level (dBm)- Cable Loss(dBm)

ERP = EIRP-2.15

Radiated Power (ERP) for Band 5											
Mode	RB/ RB SIZE	Freque ncy	Result							Polarizati on Of Max. ERP	Conclu sion
			SG Level (dBm)	Cable Loss (dBm)	Anten na Gain (dB)	Corre ction (dB)	Max. ERP Averag e (dBm)	Max. ERP Averag e (mW)			
1.4MHz Band 16 QAM	1/#M id	824.7	6.77	2.01	19.68	2.15	22.29	169.43	Horizontal	Pass	
		836.5	5.75	2.01	19.77	2.15	21.36	136.77	Horizontal	Pass	
		848.3	5.46	2.02	19.82	2.15	21.11	129.12	Horizontal	Pass	
3.0MHz Band 16 QAM	1/#M id	825.5	5.78	2.01	19.70	2.15	21.32	135.52	Horizontal	Pass	
		836.5	5.55	2.01	19.77	2.15	21.16	130.62	Horizontal	Pass	
		847.5	5.63	2.02	19.81	2.15	21.27	134.05	Horizontal	Pass	
5.0MHz Band 16 QAM	1/#M id	826.5	5.45	2.01	19.71	2.15	21.00	125.82	Horizontal	Pass	
		836.5	5.83	2.01	19.77	2.15	21.44	139.43	Horizontal	Pass	
		846.5	5.57	2.02	19.79	2.15	21.19	131.44	Horizontal	Pass	
10.0MH z Band 16 QAM	1/#M id	829	5.43	2.01	19.73	2.15	21.00	125.87	Horizontal	Pass	
		836.5	5.86	2.01	19.77	2.15	21.47	140.38	Horizontal	Pass	
		844	5.64	2.02	19.78	2.15	21.25	133.21	Horizontal	Pass	
1.4MHz Band 16 QAM	1/#M id	824.7	6.17	2.01	19.68	2.15	21.69	147.73	Vertical	Pass	
		836.5	6.24	2.01	19.77	2.15	21.85	153.07	Vertical	Pass	
		848.3	6.23	2.02	19.82	2.15	21.88	154.34	Vertical	Pass	
3.0MHz Band 16 QAM	1/#M id	825.5	5.37	2.01	19.70	2.15	20.91	123.25	Vertical	Pass	
		836.5	5.31	2.01	19.77	2.15	20.92	123.58	Vertical	Pass	
		847.5	6.21	2.02	19.81	2.15	21.85	153.24	Vertical	Pass	
5.0MHz Band 16 QAM	1/#M id	826.5	6.39	2.01	19.71	2.15	21.94	156.38	Vertical	Pass	
		836.5	5.02	2.01	19.77	2.15	20.63	115.64	Vertical	Pass	
		846.5	6.18	2.02	19.79	2.15	21.80	151.49	Vertical	Pass	
10.0MH z Band 16 QAM	1/#M id	829	6.75	2.01	19.73	2.15	22.32	170.61	Vertical	Pass	
		836.5	6.13	2.01	19.77	2.15	21.74	149.29	Vertical	Pass	
		844	5.63	2.02	19.78	2.15	21.24	132.95	Vertical	Pass	

Note:

SG Level= Signal generator output

Max. EIRP Average (dBm)= Antenna Gain(dB)+ SG Level (dBm)- Cable Loss(dBm)

ERP = EIRP-2.15

8.5 LTE BAND 7

Radiated Power (EIRP) for Band 7									
Mode	RB/RB SIZE	Frequency	Result						Conclusion
			SG Level (dBm)	Cable Loss (dBm)	Antenna Gain (dB)	Max. EIRP Average (dBm)	Max. EIRP Average (mW)	Polarization Of Max. ERP	
5.0MHz Band QPSK	1/#Mid	2502.5	1.93	4.54	27.75	25.14	326.588	Horizontal	Pass
		2535	2.10	4.69	27.72	25.13	325.837	Horizontal	Pass
		2567.5	2.17	4.71	27.71	25.17	328.852	Horizontal	Pass
10.0MHz Band QPSK	1/#Mid	2505	2.00	4.55	27.76	25.21	331.894	Horizontal	Pass
		2535	2.19	4.69	27.72	25.22	332.660	Horizontal	Pass
		2565	2.27	4.72	27.70	25.25	334.965	Horizontal	Pass
15.0MHz Band QPSK	1/#Mid	2507.5	1.99	4.55	27.77	25.21	331.894	Horizontal	Pass
		2535	2.13	4.69	27.72	25.16	328.095	Horizontal	Pass
		2562.5	2.23	4.72	27.69	25.20	331.131	Horizontal	Pass
20.0MHz Band QPSK	1/#Mid	2510	2.05	4.57	27.78	25.26	335.738	Horizontal	Pass
		2535	2.23	4.73	27.72	25.22	332.660	Horizontal	Pass
		2560	2.27	4.75	27.68	25.20	331.131	Horizontal	Pass
5.0MHz Band QPSK	1/#Mid	2502.5	0.18	4.54	27.75	23.39	218.273	Vertical	Pass
		2535	0.78	4.69	27.72	23.81	240.436	Vertical	Pass
		2567.5	0.88	4.71	27.71	23.88	244.343	Vertical	Pass
10.0MHz Band QPSK	1/#Mid	2505	0.65	4.55	27.76	23.86	243.220	Vertical	Pass
		2535	0.73	4.69	27.72	23.76	237.684	Vertical	Pass
		2565	0.35	4.72	27.70	23.33	215.278	Vertical	Pass
15.0MHz Band QPSK	1/#Mid	2507.5	0.99	4.55	27.77	24.21	263.633	Vertical	Pass
		2535	0.96	4.69	27.72	23.99	250.611	Vertical	Pass
		2562.5	0.80	4.72	27.69	23.77	238.232	Vertical	Pass
20.0MHz Band QPSK	1/#Mid	2510	0.63	4.57	27.78	23.84	242.103	Vertical	Pass
		2535	1.05	4.73	27.72	24.04	253.513	Vertical	Pass
		2560	0.56	4.75	27.68	23.49	223.357	Vertical	Pass

Radiated Power (EIRP) for Band 7									
Mode	RB/RB SIZE	Frequency	Result						Conclusion
			SG Level (dBm)	Cable Loss (dBm)	Antenna Gain (dB)	Max. EIRP Average (dBm)	Max. EIRP Average (mW)	Polarization Of Max. ERP	
5.0MHz Band 16 QAM	1/#Mid	2502.5	1.24	4.54	27.75	24.45	278.612	Horizontal	Pass
		2535	1.55	4.69	27.72	24.58	287.078	Horizontal	Pass
		2567.5	1.47	4.71	27.71	24.47	279.898	Horizontal	Pass
10.0MHz Band 16 QAM	1/#Mid	2505	1.35	4.55	27.76	24.56	285.759	Horizontal	Pass
		2535	1.34	4.69	27.72	24.37	273.527	Horizontal	Pass
		2565	1.07	4.72	27.70	24.05	254.097	Horizontal	Pass
15.0MHz Band 16 QAM	1/#Mid	2507.5	1.17	4.55	27.77	24.39	274.789	Horizontal	Pass
		2535	1.20	4.69	27.72	24.23	264.850	Horizontal	Pass
		2562.5	1.59	4.72	27.69	24.56	285.759	Horizontal	Pass
20.0MHz Band 16 QAM	1/#Mid	2510	1.29	4.57	27.78	24.50	281.838	Horizontal	Pass
		2535	1.62	4.73	27.72	24.61	289.068	Horizontal	Pass
		2560	1.52	4.75	27.68	24.45	278.612	Horizontal	Pass
5.0MHz Band 16 QAM	1/#Mid	2502.5	0.43	4.54	27.75	23.64	231.206	Vertical	Pass
		2535	0.71	4.69	27.72	23.74	236.592	Vertical	Pass
		2567.5	-0.12	4.71	27.71	22.88	194.089	Vertical	Pass
10.0MHz Band 16 QAM	1/#Mid	2505	0.33	4.55	27.76	23.54	225.944	Vertical	Pass
		2535	0.82	4.69	27.72	23.85	242.661	Vertical	Pass
		2565	1.23	4.72	27.70	24.21	263.633	Vertical	Pass
15.0MHz Band 16 QAM	1/#Mid	2507.5	0.54	4.55	27.77	23.76	237.684	Vertical	Pass
		2535	0.92	4.69	27.72	23.95	248.313	Vertical	Pass
		2562.5	-0.23	4.72	27.69	22.74	187.932	Vertical	Pass
20.0MHz Band 16 QAM	1/#Mid	2510	-0.50	4.57	27.78	22.71	186.638	Vertical	Pass
		2535	-0.27	4.73	27.72	22.72	187.068	Vertical	Pass
		2560	-0.52	4.75	27.68	22.41	174.181	Vertical	Pass

Note:

SG Level= Signal generator output

Max. EIRP Average (dBm)= Antenna Gain(dB)+ SG Level (dBm)- Cable Loss(dBm)

8.6 LTE BAND 12

Radiated Power (ERP) for Band 12											
Mode	RB/ RB SIZE	Frequ ncy	Result							Polarizati on Of Max. ERP	Conclu sion
			SG Level (dBm)	Cable Loss (dBm)	Anten na Gain (dB)	Corre ction (dB)	Max. ERP Averag e (dBm)	Max. ERP Averag e (mW)			
1.4MHz Band QPSK	1/#M id	699.7	6.78	1.91	19.21	2.15	21.93	155.91	Vertical	Pass	
		707.5	6.23	1.91	19.26	2.15	21.43	138.90	Vertical	Pass	
		715.3	6.49	1.93	19.34	2.15	21.75	149.79	Vertical	Pass	
3.0MHz Band QPSK	1/#M id	700.5	6.72	1.91	19.21	2.15	21.87	153.93	Vertical	Pass	
		707.5	6.05	1.91	19.26	2.15	21.25	133.31	Vertical	Pass	
		714.5	5.67	1.93	19.34	2.15	20.93	123.82	Vertical	Pass	
5.0MHz Band QPSK	1/#M id	701.5	6.03	1.91	19.23	2.15	21.20	131.81	Vertical	Pass	
		707.5	6.32	1.91	19.26	2.15	21.52	141.81	Vertical	Pass	
		713.5	5.33	1.92	19.33	2.15	20.59	114.55	Vertical	Pass	
10.0MH z Band QPSK	1/#M id	704	6.07	1.91	19.25	2.15	21.26	133.66	Vertical	Pass	
		707.5	5.99	1.91	19.26	2.15	21.19	131.52	Vertical	Pass	
		711	5.78	1.92	19.32	2.15	21.03	126.76	Vertical	Pass	
1.4MHz Band QPSK	1/#M id	699.7	6.50	1.91	19.21	2.15	21.65	146.19	Horizontal	Pass	
		707.5	6.92	1.91	19.26	2.15	22.12	162.87	Horizontal	Pass	
		715.3	6.00	1.93	19.34	2.15	21.26	133.71	Horizontal	Pass	
3.0MHz Band QPSK	1/#M id	700.5	5.80	1.91	19.21	2.15	20.95	124.40	Horizontal	Pass	
		707.5	6.67	1.91	19.26	2.15	21.87	153.75	Horizontal	Pass	
		714.5	6.01	1.93	19.34	2.15	21.27	134.11	Horizontal	Pass	
5.0MHz Band QPSK	1/#M id	701.5	6.18	1.91	19.23	2.15	21.35	136.39	Horizontal	Pass	
		707.5	5.68	1.91	19.26	2.15	20.88	122.60	Horizontal	Pass	
		713.5	6.26	1.92	19.33	2.15	21.52	142.05	Horizontal	Pass	
10.0MH z Band QPSK	1/#M id	704	6.20	1.91	19.25	2.15	21.39	137.72	Horizontal	Pass	
		707.5	7.09	1.91	19.26	2.15	22.29	169.43	Horizontal	Pass	
		711	6.41	1.92	19.32	2.15	21.66	146.55	Horizontal	Pass	

Note:ERP = EIRP-2.15

Radiated Power (ERP) for Band 12											
Mode	RB/ RB SIZE	Freque ncy	Result							Polarizati on Of Max. ERP	Conclu sion
			SG Level	Cable Loss (dBm)	Anten na Gain (dB)	Corre ction (dB)	Max. ERP	Max. ERP			
			(dBm)				Averag e	Averag e			
							(dBm)	(mW)			
1.4MHz Band 16 QAM	1/#M id	699.7	7.48	1.91	19.21	2.15	22.63	183.23	Vertical	Pass	
		707.5	7.76	1.91	19.26	2.15	22.96	197.70	Vertical	Pass	
		715.3	6.83	1.93	19.34	2.15	22.09	161.81	Vertical	Pass	
3.0MHz Band 16 QAM	1/#M id	700.5	7.33	1.91	19.21	2.15	22.48	177.01	Vertical	Pass	
		707.5	7.24	1.91	19.26	2.15	22.44	175.39	Vertical	Pass	
		714.5	7.28	1.93	19.34	2.15	22.54	179.47	Vertical	Pass	
5.0MHz Band 16 QAM	1/#M id	701.5	7.75	1.91	19.23	2.15	22.92	195.88	Vertical	Pass	
		707.5	6.87	1.91	19.26	2.15	22.07	161.06	Vertical	Pass	
		713.5	6.79	1.92	19.33	2.15	22.05	160.17	Vertical	Pass	
10.0MH z Band 16 QAM	1/#M id	704	7.29	1.91	19.25	2.15	22.48	177.18	Vertical	Pass	
		707.5	6.80	1.91	19.26	2.15	22.00	158.65	Vertical	Pass	
		711	7.75	1.92	19.32	2.15	23.00	199.62	Vertical	Pass	
1.4MHz Band 16 QAM	1/#M id	699.7	8.04	1.91	19.21	2.15	23.19	208.45	Horizontal	Pass	
		707.5	7.43	1.91	19.26	2.15	22.63	183.16	Horizontal	Pass	
		715.3	7.00	1.93	19.34	2.15	22.26	168.30	Horizontal	Pass	
3.0MHz Band 16 QAM	1/#M id	700.5	7.25	1.91	19.21	2.15	22.40	173.62	Horizontal	Pass	
		707.5	7.79	1.91	19.26	2.15	22.99	199.24	Horizontal	Pass	
		714.5	7.71	1.93	19.34	2.15	22.97	198.08	Horizontal	Pass	
5.0MHz Band 16 QAM	1/#M id	701.5	7.46	1.91	19.23	2.15	22.63	183.23	Horizontal	Pass	
		707.5	7.76	1.91	19.26	2.15	22.96	197.70	Horizontal	Pass	
		713.5	7.87	1.92	19.33	2.15	23.13	205.75	Horizontal	Pass	
10.0MH z Band 16 QAM	1/#M id	704	8.01	1.91	19.25	2.15	23.20	208.93	Horizontal	Pass	
		707.5	7.18	1.91	19.26	2.15	22.38	172.98	Horizontal	Pass	
		711	7.02	1.92	19.32	2.15	22.27	168.66	Horizontal	Pass	

Note:

SG Level= Signal generator output

Max. EIRP Average (dBm)= Antenna Gain(dB)+ SG Level (dBm)- Cable Loss(dBm)

ERP = EIRP-2.15

8.7 LTE BAND 17

Radiated Power (ERP) for Band 17											
Mode	RB/ RB SIZE	Freque ncy	Result							Polarizati on Of Max. ERP	Conclu sion
			SG Level (dBm)	Cable Loss (dBm)	Anten na Gain (dB)	Corre ction (dB)	Max. ERP Averag e (dBm)	Max. ERP Averag e (mW)			
5.0MHz Band QPSK	1/#M id	706.5	5.31	1.91	19.23	2.15	20.48	111.68	Vertical	Pass	
		710	5.72	1.91	19.26	2.15	20.92	123.63	Vertical	Pass	
		713.5	6.42	1.92	19.33	2.15	21.68	147.33	Vertical	Pass	
10.0MH z Band QPSK	1/#M id	709	5.93	1.91	19.25	2.15	21.12	129.34	Vertical	Pass	
		710	7.14	1.91	19.26	2.15	22.34	171.52	Vertical	Pass	
		711	6.30	1.92	19.32	2.15	21.55	142.94	Vertical	Pass	
5.0MHz Band QPSK	1/#M id	706.5	6.70	1.91	19.23	2.15	21.87	153.82	Horizontal	Pass	
		710	6.27	1.91	19.26	2.15	21.47	140.21	Horizontal	Pass	
		713.5	5.71	1.92	19.33	2.15	20.97	124.89	Horizontal	Pass	
10.0MH z Band QPSK	1/#M id	709	6.21	1.91	19.25	2.15	21.40	138.09	Horizontal	Pass	
		710	7.36	1.91	19.26	2.15	22.56	180.30	Horizontal	Pass	
		711	6.20	1.92	19.32	2.15	21.45	139.61	Horizontal	Pass	

Note: ERP = EIRP-2.15

Radiated Power (ERP) for Band 17											
Mode	RB/ RB SIZE	Freque ncy	Result							Polarizati on Of Max. ERP	Conclu sion
			SG Level	Cable Loss (dBm)	Anten na Gain (dB)	Corre ction (dB)	Max. ERP	Max. ERP			
			(dBm)				Averag e	Averag e			
							(dBm)	(mW)			
5.0MHz Band 16 QAM	1/#M id	706.5	6.89	1.91	19.23	2.15	22.06	160.70	Vertical	Pass	
		710	6.83	1.91	19.26	2.15	22.03	159.52	Vertical	Pass	
		713.5	7.30	1.92	19.33	2.15	22.56	180.30	Vertical	Pass	
10.0MH z Band 16 QAM	1/#M id	709	6.64	1.91	19.25	2.15	21.83	152.28	Vertical	Pass	
		710	6.64	1.91	19.26	2.15	21.84	152.65	Vertical	Pass	
		711	6.84	1.92	19.32	2.15	22.09	161.81	Vertical	Pass	
5.0MHz Band 16 QAM	1/#M id	706.5	7.30	1.91	19.23	2.15	22.47	176.68	Horizontal	Pass	
		710	7.27	1.91	19.26	2.15	22.47	176.77	Horizontal	Pass	
		713.5	6.71	1.92	19.33	2.15	21.97	157.55	Horizontal	Pass	
10.0MH z Band 16 QAM	1/#M id	709	6.84	1.91	19.25	2.15	22.03	159.48	Horizontal	Pass	
		710	7.38	1.91	19.26	2.15	22.58	181.13	Horizontal	Pass	
		711	6.92	1.92	19.32	2.15	22.17	164.63	Horizontal	Pass	

Note:

SG Level= Signal generator output

Max. EIRP Average (dBm)= Antenna Gain(dB)+ SG Level (dBm)- Cable Loss(dBm)

ERP = EIRP-2.15

9. SPURIOUS RADIATION EMISSION

RULE PART(S)

FCC: §2.1051, §22.917(a), §24.238(a), §27.53(c)(g)(h)(m)

LIMIT

For Band 7, the minimum permissible attenuation level of any spurious emission is $55 + \log_{10}(P)$ [Watts].

The minimum permissible attenuation level of any spurious emission is $43 + \log_{10}(P)$ [Watts], where P is the transmitter power in Watts.

TEST PROCEDURE

For Cellular equipment - Compliance with these rules is based on the use of measurement instrumentation employing a resolution bandwidth of 100 kHz or greater. In the 1 MHz bands immediately outside and adjacent to the frequency block a resolution bandwidth of at least one percent of the emission bandwidth of the fundamental emission of the transmitter may be employed. A narrower resolution bandwidth is permitted in all cases to improve measurement accuracy provided the measured power is integrated over the full required measurement bandwidth (i.e. 100 kHz or 1 percent of emission bandwidth, as specified). The emission bandwidth is defined as the width of the signal between two points, one below the carrier center frequency and one above the carrier center frequency, outside of which all emissions are attenuated at least 26 dB below the transmitter power.

For PCS equipment - Compliance with these rules is based on the use of measurement instrumentation employing a resolution bandwidth of 1 MHz or greater. However, in the 1 MHz bands immediately outside and adjacent to the frequency block a resolution bandwidth of at least one percent of the emission bandwidth of the fundamental emission of the transmitter may be employed. A narrower resolution bandwidth is permitted in all cases to improve measurement accuracy provided the measured power is integrated over the full required measurement bandwidth (i.e. 1 MHz or 1 percent of emission bandwidth, as specified). The emission bandwidth is defined as the width of the signal between two points, one below the carrier center frequency and one above the carrier center frequency, outside of which all emissions are attenuated at least 26 dB below the transmitter power.

The unwanted emission power shall be measured with a resolution bandwidth of at least 1% of the occupied bandwidth in the 1 MHz band immediately outside and adjacent to the channel edge of the equipment. Beyond the 1 MHz band immediately outside the channel edge of the equipment, a resolution bandwidth of 1 MHz shall be employed. A narrower resolution bandwidth is allowed to be used provided that the measured power is integrated over the full required measurement bandwidth of 1 MHz or 1% of the occupied bandwidth as applicable.

The power of any unwanted emissions measured from the channel edge of the equipment shall be attenuated below the transmitter power, P (dBW), as follows:

- a. for base station and subscriber equipment, other than mobile subscriber equipment, the attenuation shall not be less than $43 + 10 \text{ Log}_{10}(p)$, dB; and
- b. for mobile subscriber equipment, the attenuation shall not be less than $43 + 10 \text{ Log}_{10}(p)$, dB at the channel edges and $55 + 10 \text{ Log}_{10}(p)$ at 5.5 MHz away and beyond the channel edges where p in (a) and (b) is the transmitter power measured in watts.

MODES TESTED

- LTE Band2
LTE Band 4
- LTE Band 5
LTE Band 7
LTE Band 12
LTE Band 17

RESULTS

PASS

9.1 LTE BAND 2

QPSK EIRP POWER FOR LTE BAND 2 (1.4MHZ BANDWIDTH)

Test Results for Low Channel 1710.7MHz							
Frequency(MHz)	SG Level(dBm)	Cable Loss(dB)	Antenna Gain(dB)	Absolute Level(dBm)	Limit (dBm)	Margin(dBm)	Polarity
3701.4	-51.12	4.04	33.51	-21.65	-13	-8.65	Horizontal
3701.4	-52.78	4.04	33.51	-23.31	-13	-10.31	Vertical
5552.1	-55.32	5.24	35.84	-24.72	-13	-11.72	Vertical
5552.1	-66.29	5.24	35.84	-35.69	-13	-22.69	Horizontal
Test Results for Mid Channel 1732.5MHz							
3760	-53.49	4.04	33.56	-23.97	-13	-10.97	Horizontal
3760	-54.03	4.04	33.56	-24.51	-13	-11.51	Vertical
5640	-54.04	5.24	35.91	-23.37	-13	-10.37	Vertical
5640	-54.60	5.24	35.91	-23.93	-13	-10.93	Horizontal
Test Results for High Channel 1754.3.3MHz							
3818.6	-52.99	4.04	34.00	-23.03	-13	-10.03	Horizontal
3818.6	-54.14	4.04	34.00	-24.18	-13	-11.18	Vertical
5727.9	-57.15	5.24	36.04	-26.35	-13	-13.35	Vertical
5727.9	-56.11	5.24	36.04	-25.31	-13	-12.31	Horizontal

QPSK EIRP POWER FOR LTE BAND 2 (20.0MHZ BANDWIDTH)

Test Results for Low Channel 1710.7MHz							
Frequency(MHz)	SG Level(dBm)	Cable Loss(dB)	Antenna Gain(dB)	Absolute Level(dBm)	Limit (dBm)	Margin(dBm)	Polarity
3720	-56.81	4.07	33.54	-27.34	-13	-14.34	Horizontal
3720	-51.63	4.07	33.54	-22.16	-13	-9.16	Vertical
5580	-57.83	5.28	35.86	-27.25	-13	-14.25	Vertical
5580	-59.98	5.28	35.86	-29.40	-13	-16.40	Horizontal
Test Results for Mid Channel 1732.5MHz							
3760	-55.94	4.04	33.56	-26.42	-13	-13.42	Horizontal
3760	-52.75	4.04	33.56	-23.23	-13	-10.23	Vertical
5640	-56.75	5.24	35.91	-26.08	-13	-13.08	Vertical
5640	-57.79	5.24	35.91	-27.12	-13	-14.12	Horizontal
Test Results for High Channel 1754.3MHz							
3800	-53.96	4.04	34.00	-24.00	-13	-11.00	Horizontal
3800	-56.19	4.04	34.00	-26.23	-13	-13.23	Vertical
5700	-56.70	5.24	36.04	-25.90	-13	-12.90	Vertical
5700	-55.95	5.24	36.04	-25.15	-13	-12.15	Horizontal

Note: $P_{Mea}(dBm) = Power(dBm) + ARpl(dBm)$

Over Limit = $P_{Mea}(dBm) - Limit(dBm)$

QPSK and 16QAM have been tested, the worst mode is QPSK, only the worst mode is reflected in the report.

9.2 LTE BAND 4

QPSK EIRP POWER FOR LTE BAND 4 (1.4MHZ BANDWIDTH)

Test Results for Low Channel 1710.7MHz							
Frequency(MHz)	SG Level(dBm)	Cable Loss(dB)	Antenna Gain(dB)	Absolute Level(dBm)	Limit (dBm)	Margin(dBm)	Polarity
3421.4	-58.94	4.02	29.80	-33.16	-13	-20.16	Horizontal
3421.4	-56.53	4.02	29.80	-30.75	-13	-17.75	Vertical
5132.1	-60.76	5.24	35.84	-30.16	-13	-17.16	Vertical
5132.1	-62.40	5.24	35.84	-31.80	-13	-18.80	Horizontal
Test Results for Mid Channel 1732.5MHz							
3465	-50.61	4.03	30.00	-24.64	-13	-11.64	Horizontal
3465	-54.21	4.03	30.00	-28.24	-13	-15.24	Vertical
5197.5	-57.78	5.25	35.86	-27.17	-13	-14.17	Vertical
5197.5	-55.49	5.25	35.86	-24.88	-13	-11.88	Horizontal
Test Results for High Channel 1754.3MHz							
3508.6	-50.20	4.05	30.01	-24.24	-13	-11.24	Horizontal
3508.6	-56.53	4.05	30.01	-30.57	-13	-17.57	Vertical
5262.9	-56.60	5.26	35.86	-26.00	-13	-13.00	Vertical
5262.9	-54.88	5.26	35.86	-24.28	-13	-11.28	Horizontal

QPSK EIRP POWER FOR LTE BAND 4 (20.0MHZ BANDWIDTH)

Test Results for Low Channel 1720MHz							
Frequency(MHz)	SG Level(dBm)	Cable Loss(dB)	Antenna Gain(dB)	Absolute Level(dBm)	Limit (dBm)	Margin(dBm)	Polarity
3440	-55.50	4.02	29.80	-29.72	-13	-16.72	Horizontal
3440	-57.03	4.02	29.80	-31.25	-13	-18.25	Vertical
5160	-58.85	5.24	35.84	-28.25	-13	-15.25	Vertical
5160	-61.17	5.24	35.84	-30.57	-13	-17.57	Horizontal
Test Results for Mid Channel 1732.5MHz							
3465	-50.00	4.03	30.00	-24.03	-13	-11.03	Horizontal
3465	-53.24	4.03	30.00	-27.27	-13	-14.27	Vertical
5197.5	-59.52	5.25	35.86	-28.91	-13	-15.91	Vertical
5197.5	-58.05	5.25	35.86	-27.44	-13	-14.44	Horizontal
Test Results for High Channel 1745MHz							
2490	-53.22	2.91	27.68	-28.45	-13	-15.45	Horizontal
3490	-54.62	2.91	27.68	-29.85	-13	-16.85	Vertical
5235	-59.03	5.26	35.86	-28.43	-13	-15.43	Vertical
5235	-56.88	5.26	35.86	-26.28	-13	-13.28	Horizontal

Note: P_{Mea}(dBm)= Power(dBm)+ AR_{pl} (dBm)

. Over Limit= : P_{Mea}(dBm)-Limit(dBm)

. QPSK and 16QAM have been tested, the worst mode is QPSK, only the worst mode is reflected in the report

9.3 LTE BAND 5

QPSK EIRP POWER FOR LTE BAND 5 (1.4MHZ BANDWIDTH)

Test Results for Low Channel 824.7MHz							
Frequency(MHz)	SG Level(dBm)	Cable Loss(dB)	Antenna Gain(dB)	Absolute Level(dBm)	Limit (dBm)	Margin(dBm)	Polarity
1649.4	-49.45	2.78	27.50	-24.73	-13	-11.73	Horizontal
1649.4	-54.51	2.78	27.50	-29.79	-13	-16.79	Vertical
2474.1	-54.63	2.90	27.80	-29.73	-13	-16.73	Vertical
2474.1	-52.49	2.90	27.80	-27.59	-13	-14.59	Horizontal
Test Results For Mid Channel 836.5MHz							
1673	-51.28	2.78	27.48	-26.58	-13	-13.58	Horizontal
1673	-49.27	2.78	27.48	-24.57	-13	-11.57	Vertical
2509.5	-51.78	2.91	27.70	-26.99	-13	-13.99	Vertical
2509.5	-51.18	2.91	27.70	-26.39	-13	-13.39	Horizontal
Test Results for High Channel 848.3MHz							
1696.6	-51.92	2.78	27.43	-27.27	-13	-14.27	Horizontal
1696.6	-53.24	2.78	27.43	-28.59	-13	-15.59	Vertical
2544.9	-49.69	2.92	27.74	-24.87	-13	-11.87	Vertical
2544.9	-51.60	2.92	27.74	-26.78	-13	-13.78	Horizontal

QPSK EIRP POWER FOR LTE BAND 5 (10MHZ BANDWIDTH)

Test Results for Low Channel 829MHz							
Frequency(MHz)	SG Level(dBm)	Cable Loss(dB)	Antenna Gain(dB)	Absolute Level(dBm)	Limit (dBm)	Margin(dBm)	Polarity
1658	-52.87	2.78	27.50	-28.15	-13	-15.15	Horizontal
1658	-49.30	2.78	27.50	-24.58	-13	-11.58	Vertical
2487	-54.19	2.90	27.80	-29.29	-13	-16.29	Vertical
2487	-51.68	2.90	27.80	-26.78	-13	-13.78	Horizontal
Test Results For Mid Channel 836.5MHz							
1673	-51.72	2.78	27.48	-27.02	-13	-14.02	Horizontal
1673	-51.54	2.78	27.48	-26.84	-13	-13.84	Vertical
2509.5	-55.49	2.91	27.70	-30.70	-13	-17.70	Vertical
2509.5	-52.21	2.91	27.70	-27.42	-13	-14.42	Horizontal
Test Results for High Channel 844MHz							
1688	-55.22	2.78	27.43	-30.57	-13	-17.57	Horizontal
1688	-49.18	2.78	27.43	-24.53	-13	-11.53	Vertical
2532	-49.62	2.92	27.74	-24.80	-13	-11.80	Vertical
2532	-51.80	2.92	27.74	-26.98	-13	-13.98	Horizontal

Note: P_{Mea}(dBm)= Power(dBm)+ AR_{pl} (dBm)

Over Limit= : P_{Mea}(dBm)-Limit(dBm)

QPSK and 16QAM have been tested, the worst mode is QPSK, only the worst mode is reflected in the report

9.4 LTE BAND 7

QPSK EIRP POWER FOR LTE BAND 7 (5.0MHZ BANDWIDTH)

Test Results for Low Channel 2502.5MHz							
Frequency(MHz)	SG Level(dBm)	Cable Loss(dB)	Antenna Gain(dB)	Absolute Level(dBm)	Limit (dBm)	Margin(dBm)	Polarity
5005	-66.25	5.23	35.81	-35.67	-25	-10.67	Horizontal
5005	-63.54	5.23	35.81	-32.96	-25	-7.96	Vertical
7507.5	-68.08	5.67	36.85	-36.90	-25	-11.90	Vertical
7507.5	-63.94	5.67	36.85	-32.76	-25	-7.76	Horizontal
Test Results for Mid Channel 2535MHz							
5070	-63.10	5.23	35.82	-32.51	-25	-7.51	Horizontal
5070	-63.90	5.23	35.82	-33.31	-25	-8.31	Vertical
7605	-66.57	5.67	36.85	-35.39	-25	-10.39	Vertical
7605	-66.96	5.67	36.85	-35.78	-25	-10.78	Horizontal
Test Results for High Channel 2567.5MHz							
5135	-65.95	5.24	35.83	-35.36	-25	-10.36	Horizontal
5135	-63.64	5.24	35.83	-33.05	-25	-8.05	Vertical
7702.5	-65.47	5.68	36.87	-34.28	-25	-9.28	Vertical
7702.5	-65.88	5.68	36.87	-34.69	-25	-9.69	Horizontal

QPSK EIRP POWER FOR LTE BAND 7 (20.0MHZ BANDWIDTH)

Test Results for Low Channel 2510MHz							
Frequency(MHz)	SG Level(dBm)	Cable Loss(dB)	Antenna Gain(dB)	Absolute Level(dBm)	Limit (dBm)	Margin(dBm)	Polarity
5020	-65.37	5.23	35.82	-34.78	-25	-9.78	Horizontal
5020	-63.73	5.23	35.82	-33.14	-25	-8.14	Vertical
7530	-66.25	5.67	36.86	-35.06	-25	-10.06	Vertical
7530	-62.52	5.67	36.86	-31.33	-25	-6.33	Horizontal
Test Results for Mid Channel 2535MHz							
5070	-63.51	5.23	35.82	-32.92	-25	-7.92	Horizontal
5070	-63.21	5.23	35.82	-32.62	-25	-7.62	Vertical
7605	-65.84	5.67	36.85	-34.66	-25	-9.66	Vertical
7605	-66.48	5.67	36.85	-35.30	-25	-10.30	Horizontal
Test Results for High Channel 2560MHz							
5120	-62.48	5.24	35.83	-31.89	-25	-6.89	Horizontal
5120	-65.38	5.24	35.83	-34.79	-25	-9.79	Vertical
7680	-66.43	5.70	36.88	-35.25	-25	-10.25	Vertical
7680	-66.13	5.70	36.88	-34.95	-25	-9.95	Horizontal

Note: $P_{Mea}(dBm) = Power(dBm) + ARpl(dBm)$

Over Limit = $P_{Mea}(dBm) - Limit(dBm)$

QPSK and 16QAM have been tested, the worst mode is QPSK, only the worst mode is reflected in the report

9.5 LTE BAND 12

QPSK EIRP POWER FOR LTE BAND 12 (1.4MHZ BANDWIDTH)

Test Results for Low Channel 699.7MHz							
Frequency(MHz)	SG Level(dBm)	Cable Loss(dB)	Antenna Gain(dB)	Absolute Level(dBm)	Limit (dBm)	Margin(dBm)	Polarity
1399.4	-48.47	2.60	27.2	-23.87	-13	-10.87	Horizontal
1399.4	-49.45	2.60	27.2	-24.85	-13	-11.85	Vertical
2099.1	-50.12	2.85	27.54	-25.43	-13	-12.43	Vertical
2099.1	-49.29	2.85	27.54	-24.60	-13	-11.60	Horizontal
Test Results For Mid Channel 707.5MHz							
1415	-51.70	2.61	27.28	-27.03	-13	-14.03	Horizontal
1415	-49.12	2.61	27.28	-24.45	-13	-11.45	Vertical
2122.5	-47.72	2.87	27.59	-23.00	-13	-10.00	Vertical
2122.5	-53.09	2.87	27.59	-28.37	-13	-15.37	Horizontal
Test Results for High Channel 715.3MHz							
1430.6	-50.77	2.63	27.28	-26.12	-13	-13.12	Horizontal
1430.6	-55.17	2.63	27.28	-30.52	-13	-17.52	Vertical
2145.9	-52.26	2.88	27.60	-27.54	-13	-14.54	Vertical
2145.9	-50.74	2.88	27.60	-26.02	-13	-13.02	Horizontal

QPSK EIRP POWER FOR LTE BAND 12 (10MHZ BANDWIDTH)

Test Results for Low Channel 704MHz							
Frequency(MHz)	SG Level(dBm)	Cable Loss(dB)	Antenna Gain(dB)	Absolute Level(dBm)	Limit (dBm)	Margin(dBm)	Polarity
1408	-47.96	2.61	27.26	-23.31	-13	-10.31	Horizontal
1408	-52.54	2.61	27.26	-27.89	-13	-14.89	Vertical
2112	-52.06	2.87	27.58	-27.35	-13	-14.35	Vertical
2112	-52.33	2.87	27.58	-27.62	-13	-14.62	Horizontal
Test Results for Mid Channel 707.5MHz							
1415	-51.15	2.61	27.28	-26.48	-13	-13.48	Horizontal
1415	-54.15	2.61	27.28	-29.48	-13	-16.48	Vertical
2122.5	-51.85	2.87	27.59	-27.13	-13	-14.13	Vertical
2122.5	-52.00	2.87	27.59	-27.28	-13	-14.28	Horizontal
Test Results for High Channel 711MHz							
1422	-53.88	2.62	27.28	-29.22	-13	-16.22	Horizontal
1422	-49.78	2.62	27.28	-25.12	-13	-12.12	Vertical
2133	-52.53	2.87	27.60	-27.80	-13	-14.80	Vertical
2133	-51.92	2.87	27.60	-27.19	-13	-14.19	Horizontal

Note: P_{Mea}(dBm)= Power(dBm)+ AR_{pl} (dBm)

Over Limit= : P_{Mea}(dBm)-Limit(dBm)

QPSK and 16QAM have been tested, the worst mode is QPSK, only the worst mode is reflected in the report

9.6 LTE BAND 17

QPSK EIRP POWER FOR LTE BAND 17 (5MHZ BANDWIDTH)

Test Results for Low Channel 706.5MHz							
Frequency(MHz)	SG Level(dBm)	Cable Loss(dB)	Antenna Gain(dB)	Absolute Level(dBm)	Limit (dBm)	Margin(dBm)	Polarity
1413	-52.04	2.61	27.28	-27.37	-13	-14.37	Horizontal
1413	-53.95	2.61	27.28	-29.28	-13	-16.28	Vertical
2119.5	-53.48	2.87	27.59	-28.76	-13	-15.76	Vertical
2119.5	-51.19	2.87	27.59	-26.47	-13	-13.47	Horizontal
Test Results For Mid Channel 710MHz							
1420	-52.27	2.62	27.30	-27.59	-13	-14.59	Horizontal
1420	-54.38	2.62	27.30	-29.70	-13	-16.70	Vertical
2130	-55.13	2.87	27.62	-30.38	-13	-17.38	Vertical
2130	-56.29	2.87	27.62	-31.54	-13	-18.54	Horizontal
Test Results for High Channel 713.5MHz							
1427	-54.61	2.66	27.28	-29.99	-13	-16.99	Horizontal
1427	-55.45	2.66	27.28	-30.83	-13	-17.83	Vertical
2140.5	-53.77	2.88	27.60	-29.05	-13	-16.05	Vertical
2140.5	-53.99	2.88	27.60	-29.27	-13	-16.27	Horizontal

QPSK EIRP POWER FOR LTE BAND 17 (10MHZ BANDWIDTH)

Test Results for Low Channel 709MHz							
Frequency(MHz)	SG Level(dBm)	Cable Loss(dB)	Antenna Gain(dB)	Absolute Level(dBm)	Limit (dBm)	Margin(dBm)	Polarity
1418	-54.18	2.62	27.30	-29.50	-13	-16.50	Horizontal
1418	-51.34	2.62	27.30	-26.66	-13	-13.66	Vertical
2127	-53.21	2.87	27.62	-28.46	-13	-15.46	Vertical
2127	-54.38	2.87	27.62	-29.63	-13	-16.63	Horizontal
Test Results for Mid Channel 710MHz							
1420	-53.13	2.62	27.30	-28.45	-13	-15.45	Horizontal
1420	-51.11	2.62	27.30	-26.43	-13	-13.43	Vertical
2130	-53.81	2.87	27.62	-29.06	-13	-16.06	Vertical
2130	-51.71	2.87	27.62	-26.96	-13	-13.96	Horizontal
Test Results for High Channel 711MHz							
1422	-50.72	2.62	27.30	-26.04	-13	-13.04	Horizontal
1422	-51.88	2.62	27.30	-27.20	-13	-14.20	Vertical
2133	-53.09	2.87	27.62	-28.34	-13	-15.34	Vertical
2133	-55.44	2.87	27.62	-30.69	-13	-17.69	Horizontal

Note: $P_{Mea}(dBm) = Power(dBm) + ARpl (dBm)$

Over Limit = $P_{Mea}(dBm) - Limit(dBm)$

QPSK and 16QAM have been tested, the worst mode is QPSK, only the worst mode is reflected in the report

10. FREQUENCY STABILITY

RULE PART(S)

FCC: §2.1055, §22.355, §24.235, §27.54

LIMITS

§22.355 - The carrier frequency shall not depart from the reference frequency in excess of ± 2.5 ppm for mobile stations.

§24.235 - The frequency stability shall be sufficient to ensure that the fundamental emission stays within the authorized frequency block.

TEST PROCEDURE

Use CMW 500 with Frequency Error measurement capability.

- Temp. = -30° to $+50^{\circ}\text{C}$
- Voltage = low voltage, DC 3.4V, Normal, DC 3.85V and High voltage, DC 4.4V.

Frequency Stability vs Temperature:

The EUT is placed inside a temperature chamber. The temperature is set to -30°C and allowed to stabilize. After sufficient soak time, the transmitting frequency error is measured. The temperature is increased by 10 degrees, allowed to stabilize and soak, and then the measurement is repeated. This is repeated until $+50^{\circ}\text{C}$ is reached.

Frequency Stability vs Voltage:

The peak frequency error is recorded (worst-case).

MODES TESTED

- LTE Band 2
LTE Band 4
- LTE Band 5
LTE Band 7
LTE Band 12
LTE Band 17

RESULTS

See the following pages.

10.1 LTE BAND 2

QPSK, (20MHz BANDWIDTH)

Frequency error vs. Voltage

Voltage [Vdc]	Frequency [MHz]	Frequency* Error[Hz]	Frequency Error[ppm]	Limit [ppm]
BAND 2 QPSK, (CH 18900 RB size 100 RB Offset 0 20MHz BANDWIDTH)				
3.4	1880	13.0	0.006915	2.5
3.85	1880	14.2	0.007553	2.5
4.4	1880	13.8	0.007340	2.5

Frequency error vs. Temperature

Temperature [° C]	Frequency [MHz]	Frequency* Error[Hz]	Frequency Error[ppm]	Limit [ppm]
BAND 2 QPSK, (CH 18900 RB size 100 RB Offset 0 20MHz BANDWIDTH)				
Normal (25C)	1880	12.2	0.006489	2.5
Extreme (50C)	1880	11.8	0.006277	2.5
Extreme (40C)	1880	14.1	0.007500	2.5
Extreme (30C)	1880	13.7	0.007287	2.5
Extreme (10C)	1880	13.7	0.007287	2.5
Extreme (0C)	1880	12.3	0.006543	2.5
Extreme (-10C)	1880	13.4	0.007128	2.5
Extreme (-20C)	1880	13.7	0.007287	2.5
Extreme (-30C)	1880	14.6	0.007766	2.5

16QAM, (20MHz BANDWIDTH)

Frequency error vs. Voltage

Voltage [Vdc]	Frequency [MHz]	Frequency* Error[Hz]	Frequency Error[ppm]	Limit [ppm]
BAND 2 16QAM, (CH 18900 RB size 100 RB Offset 0 20MHz BANDWIDTH)				
3.4	1880	9.5	0.005053	2.5
3.85	1880	8.5	0.004521	2.5
4.4	1880	8.4	0.004468	2.5

Frequency error vs. Temperature

Temperature [° C]	Frequency [MHz]	Frequency* Error[Hz]	Frequency Error[ppm]	Limit [ppm]
BAND 2 16QAM, (CH 18900 RB size 100 RB Offset 0 20MHz BANDWIDTH)				
Normal (25C)	1880	9.8	0.005213	2.5
Extreme (50C)	1880	9.2	0.004894	2.5
Extreme (40C)	1880	7.9	0.004202	2.5
Extreme (30C)	1880	9.0	0.004787	2.5
Extreme (10C)	1880	9.1	0.004840	2.5
Extreme (0C)	1880	7.9	0.004202	2.5
Extreme (-10C)	1880	8.7	0.004628	2.5
Extreme (-20C)	1880	8.9	0.004734	2.5
Extreme (-30C)	1880	8.3	0.004415	2.5

*Note: Frequency error measurements were made by using the build-in capability of the Wireless Communication Test Set.

10.2 LTE BAND 4

QPSK, (10MHz BANDWIDTH)

Frequency error vs. Voltage

Voltage [Vdc]	Frequency [MHz]	Frequency* Error[Hz]	Frequency Error[ppm]	Limit [ppm]
BAND 4 QPSK, (CH 20175 RB size 100 RB Offset 0 20MHz BANDWIDTH)				
3.4	1732.5	8.5	0.004903	2.5
3.85	1732.5	8.9	0.005142	2.5
4.4	1732.5	8.8	0.005055	2.5

Frequency error vs. Temperature

Temperature [°C]	Frequency [MHz]	Frequency* Error[Hz]	Frequency Error[ppm]	Limit [ppm]
BAND 4 QPSK, (CH 20175 RB size 100 RB Offset 0 20MHz BANDWIDTH)				
Normal (25C)	1732.5	8.2	0.004735	2.5
Extreme (50C)	1732.5	9.2	0.005313	2.5
Extreme (40C)	1732.5	7.6	0.004390	2.5
Extreme (30C)	1732.5	6.1	0.003512	2.5
Extreme (10C)	1732.5	7.0	0.004050	2.5
Extreme (0C)	1732.5	9.3	0.005355	2.5
Extreme (-10C)	1732.5	8.1	0.004664	2.5
Extreme (-20C)	1732.5	6.9	0.003957	2.5
Extreme (-30C)	1732.5	8.1	0.004672	2.5

16QAM, (20MHz BANDWIDTH)

Frequency error vs. Voltage

Voltage [Vdc]	Frequency [MHz]	Frequency* Error[Hz]	Frequency Error[ppm]	Limit [ppm]
BAND 4 16QAM, (CH 20175 RB size 100 RB Offset 0 20MHz BANDWIDTH)				
3.4	1732.5	9.6	0.005541	2.5
3.85	1732.5	8.5	0.004906	2.5
4.4	1732.5	7.8	0.004502	2.5

Frequency error vs. Temperature

Temperature [°C]	Frequency [MHz]	Frequency* Error[Hz]	Frequency Error[ppm]	Limit [ppm]
BAND 4 16QAM, (CH 20175 RB size 100 RB Offset 0 20MHz BANDWIDTH)				
Normal (25C)	1732.5	9.9	0.005714	2.5
Extreme (50C)	1732.5	8.9	0.005137	2.5
Extreme (40C)	1732.5	8.1	0.004675	2.5
Extreme (30C)	1732.5	9.1	0.005253	2.5
Extreme (10C)	1732.5	8.4	0.004848	2.5
Extreme (0C)	1732.5	7.9	0.004560	2.5
Extreme (-10C)	1732.5	8.8	0.005079	2.5
Extreme (-20C)	1732.5	8.7	0.005022	2.5
Extreme (-30C)	1732.5	7.8	0.004502	2.5

***Note:** Frequency error measurements were made by using the build-in capability of the Wireless Communication Test Set.

10.3 LTE BAND 5

QPSK, (10MHz BANDWIDTH)

Frequency error vs. Voltage

Voltage [Vdc]	Frequency [MHz]	Frequency* Error[Hz]	Frequency Error[ppm]	Limit [ppm]
BAND 5 QPSK, (CH 20525 RB size 50 RB Offset 0 10MHz BANDWIDTH)				
3.4	836.5	5.4	0.006455	2.5
3.85	836.5	6.7	0.008010	2.5
4.4	836.5	4.9	0.005858	2.5

Frequency error vs. Temperature

Temperature [° C]	Frequency [MHz]	Frequency* Error[Hz]	Frequency Error[ppm]	Limit [ppm]
BAND 5 QPSK, (CH 20525 RB size 50 RB Offset 0 10MHz BANDWIDTH)				
Normal (25C)	836.5	6.3	0.007531	2.5
Extreme (50C)	836.5	5.6	0.006695	2.5
Extreme (40C)	836.5	6.2	0.007412	2.5
Extreme (30C)	836.5	6.2	0.007412	2.5
Extreme (10C)	836.5	5.8	0.006934	2.5
Extreme (0C)	836.5	5.3	0.006336	2.5
Extreme (-10C)	836.5	6.0	0.007173	2.5
Extreme (-20C)	836.5	6.1	0.007292	2.5
Extreme (-30C)	836.5	6.6	0.007890	2.5

16QAM, (10MHz BANDWIDTH)

Frequency error vs. Voltage

Voltage [Vdc]	Frequency [MHz]	Frequency* Error[Hz]	Frequency Error[ppm]	Limit [ppm]
BAND 5 16QAM, (CH 20525 RB size 50 RB Offset 0 10MHz BANDWIDTH)				
3.4	836.5	5.5	0.006575	2.5
3.85	836.5	6.3	0.007531	2.5
4.4	836.5	4.9	0.005858	2.5

Frequency error vs. Temperature

Temperature [° C]	Frequency [MHz]	Frequency* Error[Hz]	Frequency Error[ppm]	Limit [ppm]
BAND 5 16QAM, (CH 20525 RB size 50 RB Offset 0 10MHz BANDWIDTH)				
Normal (25C)	836.5	6.4	0.007651	2.5
Extreme (50C)	836.5	5.7	0.006814	2.5
Extreme (40C)	836.5	6.4	0.007651	2.5
Extreme (30C)	836.5	6.6	0.007890	2.5
Extreme (10C)	836.5	4.9	0.005858	2.5
Extreme (0C)	836.5	5.6	0.006695	2.5
Extreme (-10C)	836.5	5.1	0.006097	2.5
Extreme (-20C)	836.5	6.3	0.007531	2.5
Extreme (-30C)	836.5	6.8	0.008129	2.5

***Note:** Frequency error measurements were made by using the build-in capability of the Wireless Communication Test Set.

10.4 LTE BAND 7

QPSK, (20MHz BANDWIDTH)

Frequency error vs. Voltage

Voltage [Vdc]	Frequency [MHz]	Frequency* Error[Hz]	Frequency Error[ppm]	Limit [ppm]
BAND 7 QPSK, (CH 21100 RB size 100 RB Offset 0 20MHz BANDWIDTH)				
3.4	2535	10.0	0.003945	2.5
3.85	2535	8.5	0.003353	2.5
4.4	2535	7.9	0.003116	2.5

Frequency error vs. Temperature

Temperature [° C]	Frequency [MHz]	Frequency* Error[Hz]	Frequency Error[ppm]	Limit [ppm]
BAND 7 QPSK, (CH 21100 RB size 100 RB Offset 0 20MHz BANDWIDTH)				
Normal (25C)	2535	9.0	0.003550	2.5
Extreme (50C)	2535	9.3	0.003669	2.5
Extreme (40C)	2535	8.2	0.003235	2.5
Extreme (30C)	2535	9.2	0.003629	2.5
Extreme (10C)	2535	8.3	0.003274	2.5
Extreme (0C)	2535	8.2	0.003235	2.5
Extreme (-10C)	2535	9.1	0.003590	2.5
Extreme (-20C)	2535	9.1	0.003590	2.5
Extreme (-30C)	2535	8.1	0.003195	2.5

16QAM, (20MHz BANDWIDTH)

Frequency error vs. Voltage

Voltage [Vdc]	Frequency [MHz]	Frequency* Error[Hz]	Frequency Error[ppm]	Limit [ppm]
BAND 7 16QAM, (CH 21100 RB size 100 RB Offset 0 20MHz BANDWIDTH)				
3.4	2535	6.8	0.002682	2.5
3.85	2535	6.4	0.002525	2.5
4.4	2535	5.9	0.002327	2.5

Frequency error vs. Temperature

Temperature [° C]	Frequency [MHz]	Frequency* Error[Hz]	Frequency Error[ppm]	Limit [ppm]
BAND 7 16QAM, (CH 21100 RB size 100 RB Offset 0 20MHz BANDWIDTH)				
Normal (25C)	2535	7.0	0.002761	2.5
Extreme (50C)	2535	5.7	0.002249	2.5
Extreme (40C)	2535	5.4	0.002130	2.5
Extreme (30C)	2535	6.8	0.002682	2.5
Extreme (10C)	2535	6.1	0.002406	2.5
Extreme (0C)	2535	5.5	0.002170	2.5
Extreme (-10C)	2535	4.8	0.001893	2.5
Extreme (-20C)	2535	6.0	0.002367	2.5
Extreme (-30C)	2535	5.8	0.002288	2.5

***Note:** Frequency error measurements were made by using the build-in capability of the Wireless Communication Test Set.

10.5 LTE BAND 12

QPSK, (10MHz BANDWIDTH)

Frequency error vs. Voltage

Voltage [Vdc]	Frequency [MHz]	Frequency* Error[Hz]	Frequency Error[ppm]	Limit [ppm]
BAND 12 QPSK, (CH 23095 RB size 50 RB Offset 0 10MHz BANDWIDTH)				
3.4	707.5	8.7	0.012297	2.5
3.85	707.5	10.3	0.014558	2.5
4.4	707.5	8.4	0.011873	2.5

Frequency error vs. Temperature

Temperature [° C]	Frequency [MHz]	Frequency* Error[Hz]	Frequency Error[ppm]	Limit [ppm]
BAND 12 QPSK, (CH 23095 RB size 50 RB Offset 0 10MHz BANDWIDTH)				
Normal (25C)	707.5	8.4	0.011873	2.5
Extreme (50C)	707.5	7.4	0.010459	2.5
Extreme (40C)	707.5	7.1	0.010035	2.5
Extreme (30C)	707.5	8.1	0.011449	2.5
Extreme (10C)	707.5	7.2	0.010177	2.5
Extreme (0C)	707.5	9.0	0.012721	2.5
Extreme (-10C)	707.5	8.2	0.011590	2.5
Extreme (-20C)	707.5	9.2	0.013004	2.5
Extreme (-30C)	707.5	8.3	0.011731	2.5

16QAM, (10MHz BANDWIDTH)

Frequency error vs. Voltage

Voltage [Vdc]	Frequency [MHz]	Frequency* Error[Hz]	Frequency Error[ppm]	Limit [ppm]
BAND 12 16QAM, (CH 23095 RB size 50 RB Offset 0 10MHz BANDWIDTH)				
3.4	707.5	7.3	0.010318	2.5
3.85	707.5	8.7	0.012297	2.5
4.4	707.5	7.7	0.010883	2.5

Frequency error vs. Temperature

Temperature [° C]	Frequency [MHz]	Frequency* Error[Hz]	Frequency Error[ppm]	Limit [ppm]
BAND 12 QPSK, (CH 23095 RB size 50 RB Offset 0 10MHz BANDWIDTH)				
Normal (25C)	707.5	6.5	0.009187	2.5
Extreme (50C)	707.5	5.5	0.007774	2.5
Extreme (40C)	707.5	6.4	0.009046	2.5
Extreme (30C)	707.5	-7.7	-0.010883	2.5
Extreme (10C)	707.5	-8.2	-0.011590	2.5
Extreme (0C)	707.5	2.9	0.004099	2.5
Extreme (-10C)	707.5	-5.2	-0.007350	2.5
Extreme (-20C)	707.5	-8.7	-0.012297	2.5
Extreme (-30C)	707.5	-10.2	-0.014417	2.5

***Note:** Frequency error measurements were made by using the build-in capability of the Wireless Communication Test Set.

10.6 LTE BAND 17

QPSK, (10MHz BANDWIDTH)

Frequency error vs. Voltage

Voltage [Vdc]	Frequency [MHz]	Frequency* Error[Hz]	Frequency Error[ppm]	Limit [ppm]
BAND 17 QPSK, (CH 23790 RB size 50 RB Offset 0 10MHz BANDWIDTH)				
3.4	710.0	9.7	0.013662	2.5
3.85	710.0	8.7	0.012254	2.5
4.4	710.0	7.7	0.010845	2.5

Frequency error vs. Temperature

Temperature [° C]	Frequency [MHz]	Frequency* Error[Hz]	Frequency Error[ppm]	Limit [ppm]
BAND 17 QPSK, (CH 23790 RB size 50 RB Offset 0 10MHz BANDWIDTH)				
Normal (25C)	710.0	9.5	0.013380	2.5
Extreme (50C)	710.0	9.2	0.012958	2.5
Extreme (40C)	710.0	7.6	0.010704	2.5
Extreme (30C)	710.0	8.6	0.012113	2.5
Extreme (10C)	710.0	9.3	0.013099	2.5
Extreme (0C)	710.0	7.6	0.010704	2.5
Extreme (-10C)	710.0	9.5	0.013380	2.5
Extreme (-20C)	710.0	9.0	0.012676	2.5
Extreme (-30C)	710.0	8.4	0.011831	2.5

16QAM, (10MHz BANDWIDTH)

Frequency error vs. Voltage

Voltage [Vdc]	Frequency [MHz]	Frequency* Error[Hz]	Frequency Error[ppm]	Limit [ppm]
BAND 17 16QAM, (CH 23790 RB size 50 RB Offset 0 10MHz BANDWIDTH)				
3.4	710.0	9.7	0.013662	2.5
3.85	710.0	9.1	0.012817	2.5
4.4	710.0	8.8	0.012394	2.5

Frequency error vs. Temperature

Temperature [° C]	Frequency [MHz]	Frequency* Error[Hz]	Frequency Error[ppm]	Limit [ppm]
BAND 17 QPSK, (CH 23790 RB size 50 RB Offset 0 10MHz BANDWIDTH)				
Normal (25C)	710.0	9.6	0.013521	2.5
Extreme (50C)	710.0	9.0	0.012676	2.5
Extreme (40C)	710.0	8.0	0.011268	2.5
Extreme (30C)	710.0	9.0	0.012676	2.5
Extreme (10C)	710.0	8.3	0.011690	2.5
Extreme (0C)	710.0	8.3	0.011690	2.5
Extreme (-10C)	710.0	9.7	0.013662	2.5
Extreme (-20C)	710.0	9.0	0.012676	2.5
Extreme (-30C)	710.0	8.1	0.011408	2.5

***Note:** Frequency error measurements were made by using the build-in capability of the Wireless Communication Test Set.

11. Peak-to-Average Ratio

11.1 Description of the PAR Measurement

The peak-to-average ratio (PAR) of the transmission may not exceed 13 dB.

11.2 Measuring Instruments

See list of measuring instruments of this test report.

11.3 Test Procedures

1. The EUT was connected to Spectrum Analyzer and Base Station via power divider.
2. The RF output of EUT was connected to the spectrum analyzer by RF cable and attenuator. The path loss was compensated to the results for each measurement.
3. For GSM/EGPRS operating modes:
 - a. Set the RBW = 1MHz, VBW = 1MHz, Peak detector in spectrum analyzer.
 - b. Set EUT in maximum power output, and triggered the burst signal.
 - c. Measured respectively the Peak level and Mean level, and the deviation was recorded as Peak to Average Ratio.
4. For UMTS operating modes:
 - a. Set the CCDF (Complementary Cumulative Distribution Function) option in spectrum analyzer.
 - b. The highest RF powers were measured and recorded the maximum PAPR level associated with a probability of 0.1 %.

11.4 Test Setup

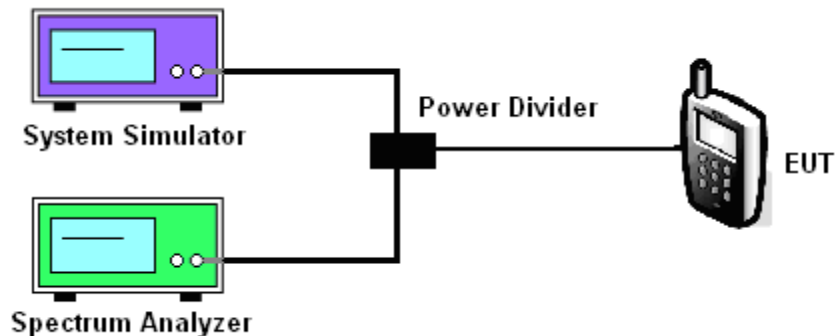

MODES TESTED

- LTE Band 2/4/5/7/12/17
-

Test data reference attachment.

----END OF REPORT----