

FCC CFR47 PART 22H, 24E, 27 CERTIFICATION TEST REPORT

FCC ID: 2ANMU-WP5

Product: Smart Phone
Trade Mark: OUKITEL
Model Number: WP5
Family Model: N/A
Report No.: S20022700103005

Prepared for

SHENZHEN YUNJI INTELLIGENT TECHNOLOGY CO.,LTD
A2 2F BUILDING ENET NEW INDUSTRIAL PARK, DAFU INDUSTRIAL ZONE
GUANLAN, LONGHUA, SHENZHEN, 518XXX China

Prepared by

Shenzhen NTEK Testing Technology Co., Ltd.
1/F, Building E, Fenda Science Park, Sanwei Community, Xixiang Street
Bao'an District, Shenzhen 518126 P.R. China
Tel.: +86-755-6115 9388 Fax.: +86-755-6115 6599
Website: <http://www.ntek.org.cn>

TEST RESULT CERTIFICATION

Applicant's name : SHENZHEN YUNJI INTELLIGENT TECHNOLOGY CO.,LTD
Address : A2 2F BUILDING ENET NEW INDUSTRIAL PARK, DAFU INDUSTRIAL ZONE, GUANLAN, LONGHUA, SHENZHEN, 518XXX China
Manufacturer's Name : SHENZHEN YUNJI INTELLIGENT TECHNOLOGY CO.,LTD
Address : A2 2F BUILDING ENET NEW INDUSTRIAL PARK, DAFU INDUSTRIAL ZONE, GUANLAN, LONGHUA, SHENZHEN, 518XXX China
Product name : Smart Phone
Model and/or type reference : WP5
Family Model: N/A
Standards : FCC CFR 47 Part 22H, Part 24E, Part 27
Test procedure : ANSI C63.26:2015
ANSI/TIA-603-E-2016

This device described above has been tested by NTEK, and the test results show that the equipment under test (EUT) is in compliance with the FCC requirements. And it is applicable only to the tested sample identified in the report.

This report shall not be reproduced except in full, without the written approval of NTEK, this document may be altered or revised by NTEK, personal only, and shall be noted in the revision of the document.

Date of Test
Date (s) of performance of tests : 27 Feb. 2020 ~ 19 Mar. 2020
Date of Issue : 19 Mar. 2020
Test Result : Pass

Testing Engineer : Allen Liu
Technical Manager : Jason Chen
Authorized Signatory : Sam Chen

TABLE OF CONTENTS

1. GENERAL INFORMATION	5
1.1 PRODUCT DESCRIPTION	5
1.2 RELATED SUBMITTAL(S) / GRANT (S).....	7
1.3 TEST METHODOLOGY.....	7
1.4 TEST FACILITY.....	7
MEASUREMENT UNCERTAINTY	7
1.5 SPECIAL ACCESSORIES.....	7
1.6 WORST-CASE CONFIGURATION AND MODE.....	7
2. SYSTEM TEST CONFIGURATION	8
2.1 EUT CONFIGURATION.....	8
2.2 EUT EXERCISE	8
2.3 CONFIGURATION OF EUT SYSTEM.....	8
2.4 TEST SETUP	9
3.TEST AND MEASUREMENT EQUIPMENT	10
4. OUTPUT POWER.....	11
4.1 OUTPUT POWER MEASUREMENT	11
5. OCCUPIED BANDWIDTH.....	13
6. BANDEDGE AND EMISSION MASK.....	14
7. OUT OF BAND EMISSIONS.....	15
7.1 MEASUREMENT METHOD	15
8. RADIATED MEASUREMENT	16
8.1. RADIATED POWER (ERP & EIRP).....	16
8.2 LTE BAND 2	17
8.3 LTE BAND 4	21
8.4 LTE BAND 5	25

8.5 LTE BAND 7	27
8.6 LTE BAND 12	29
8.7 LTE BAND 17	31
9. SPURIOUS RADIATION EMISSION	33
9.1 LTE BAND 2	35
9.2 LTE BAND 4	37
9.3 LTE BAND 5	39
9.4 LTE BAND 7	41
9.5 LTE BAND 12	43
9.6 LTE BAND 17	45
10. FREQUENCY STABILITY	47
10.1 LTE BAND 2	48
10.2 LTE BAND 4	50
10.3 LTE BAND 5	52
10.4 LTE BAND 7	54
10.5 LTE BAND 12	56
10.6 LTE BAND 17	58
11. PEAK-TO-AVERAGE RATIO	60
11.1 Description of the PAR Measurement	60
11.2 Measuring Instruments	60
11.3 Test Procedures	60
11.4 Test Setup	60

1. GENERAL INFORMATION

1.1 PRODUCT DESCRIPTION

A major technical description of EUT is described as following:

Product Designation:	Smart Phone
Trade Mark	OUKITEL
Model Name	WP5
Family Model	N/A
Model Difference	N/A
FCC ID:	2ANMU-WP5
Frequency Bands:	U.S. Bands: <input checked="" type="checkbox"/> LTE FDD Band 2,4,5,7,12,17
Frequency Range:	LTE FDD Band 2 Uplink: 1850MHz-1910MHz, Downlink: 1930MHz-1990MHz; LTE FDD Band 4 Uplink: 1710MHz-1755MHz, Downlink: 2110MHz-2155MHz; LTE FDD Band 5 Uplink: 824MHz-849MHz, Downlink: 869MHz-894MHz; LTE-FDD Band 7 Uplink: 2500MHz-2570MHz, Downlink: 2620MHz-2690MHz; LTE FDD Band 12 Uplink: 699MHz-716MHz, Downlink: 729MHz-746MHz; LTE FDD Band 17 Uplink: 704MHz-716MHz, Downlink: 734MHz-746MHz;
Type of Modulation:	QPSK/16QAM
SIM Card	SIM 1 and SIM 2 is a chipset unit and tested as a single chipset. The SIM 1 is chosen for test.
Antenna:	FPC Antenna
Antenna gain:	LTE FDD Band 2: 1.58dBi LTE FDD Band 4: 1.42dBi LTE FDD Band 5: -2.51dBi LTE FDD Band 7: 0.63dBi LTE FDD Band 12: -3.42dBi LTE FDD Band 17: -3.42dBi
Power Supply:	<input checked="" type="checkbox"/> DC supply: DC 3.85V, 8000mAh ,30.8Wh from Battery or DC 5V from USB Port
Adapter:	<input checked="" type="checkbox"/> Adapter: Model:HJ-0502000W2-US Input: 100-240V~50/60Hz 0.3A Output: 5V 2.0A

Extreme Vol. Limits:	DC 3.4V to DC 4.4V (Nominal DC 3.85V) (Note 1)
HW Version	E959-main-pcb
SW Version	OUKITEL_C17 Pro_V1.0
** Note1: The High Voltage DC 4.4V and Low Voltage 3.4V was declared by manufacturer, The EUT couldn't be operate normally with higher or lower voltage.	

1.2 RELATED SUBMITTAL(S) / GRANT (S)

This submittal(s) (test report) is intended for **FCC ID: 2ANMU-WP5** filing to comply with the FCC Part 22H&24E &27.

1.3 TEST METHODOLOGY

The tests documented in this report were performed in accordance with ANSI/TIA-603-E-2016, FCC CFR 47 Part 2, Part 22, Part 24, Part 27, ANSI C63.26:2015.

1.4 TEST FACILITY

The test site used to collect the radiated data is located at:

ShenZhen NTEK Testing Technology Co., Ltd.

1/F, Building E, Fenda Science Park, Sanwei Community, Xixiang Street, Bao'an District, Shenzhen 518126 P.R.China.

The test site is constructed and calibrated to meet the FCC requirements in documents ANSI C63.26:2015& ANSI C63.4: 2014.

FCC Registration No.:463705

IC Registration No.:9270A-1,

CNAS Registration No.:L5516

MEASUREMENT UNCERTAINTY

The reported uncertainty of measurement, where expended uncertainty U is based on a standard uncertainty multiplied by a coverage factor of k=2, providing a level of confidence of approximately 95 %.

No.	Item	Uncertainty
1	Measuring Uncertainty for a Level of Confidence of 95% (U = 2Uc(y))	2.5dB

1.5 SPECIAL ACCESSORIES

The battery and the charger, earphone supplied by the applicant were used as accessories and being tested with EUT intended for FCC grant together.

1.6 WORST-CASE CONFIGURATION AND MODE

The worst-case scenario for all measurements is based on the investigation results.

The device has LTE Bands of: Band 2, Band 4, Band 5, Band 7, Band 12, Band 17.

The RB Size was selected to measure for peak or average ERP and EIRP, which was based on the conducted power verification baseline data.

For the fundamental investigation of radiated emissions, the EUT is investigated for vertical and horizontal antenna orientations and X Y and Z orientations of the EUT alone. After the investigations the worst case was determined to be at X orientation for all LTE bands.

2. SYSTEM TEST CONFIGURATION

2.1 EUT CONFIGURATION

The EUT configuration for testing is installed on RF field strength measurement to meet the Commission’s requirement and operating in a manner which intends to maximize its emission characteristics in a continuous normal application.

2.2 EUT EXERCISE

The Transmitter was operated in the maximum output power mode through Communication Tester. The TX frequency was fixed which was for the purpose of the measurements.

2.3 CONFIGURATION OF EUT SYSTEM

Table 2-1 Equipment Used in EUT System

Item	Equipment	Model No.	ID or Specification	Note
1	Smart Phone	WP5	FCC ID: 2ANMU-WP5	EUT

*Note: All the accessories have been used during the test.
the following “EUT” in setup diagram means EUT system.*

2.4 TEST SETUP

CONDUCTED SETUP DIAGRAM FOR TESTS

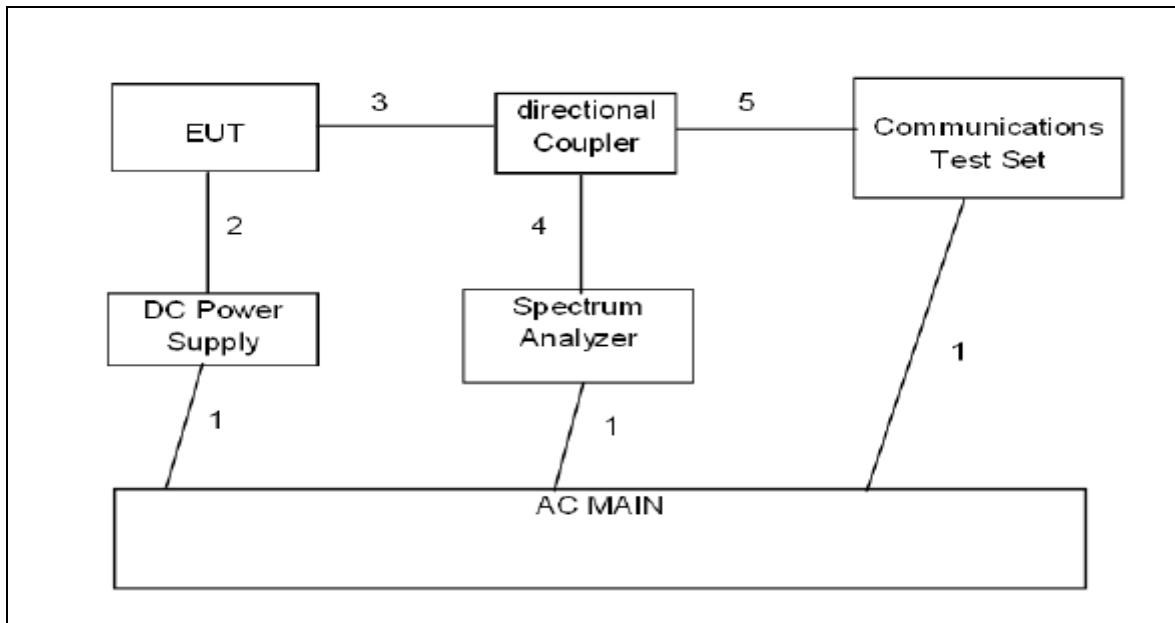

RADIATED SETUP DIAGRAM FOR TESTS

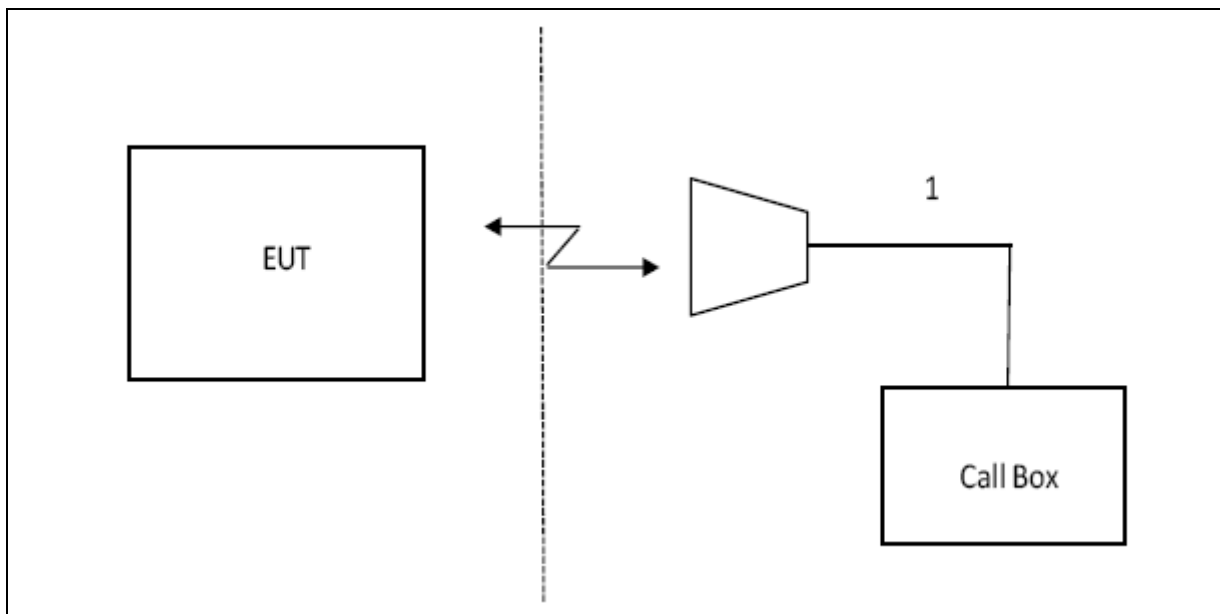

3. TEST AND MEASUREMENT EQUIPMENT

The following test and measurement equipment was utilized for the tests documented in this report:

NAME OF EQUIPMENT	MANUFACTURER	MODEL	SERIAL NUMBER	NEXT CAL. DATE
SPECTRUM ANALYZER	AGILENT	N9020A	MY49100060	2019.10.07
TEST RECEIVER	R&S	ESCI	A0304218	2020.05.12
COMMUNICATION TESTER	R&S	CMU200	117858	2020.05.12
COMMUNICATION TESTER	R&S	CMW500	148500	2020.05.12
TEST RECEIVER	R&S	ESPI	101318	2020.05.12
LISN	SCHWARZBECK	NSLK8127	A0304233	2020.05.12
CLIMATE CHAMBER	ALBATROSS	--	--	2020.05.12
Loop Antenna	ARA	PLA-1030/B	1029	2020.05.12
Biological Antenna	TESEQ	CBL6111D	31216	2020.05.12
Horn Antenna	EM	EM-AH-10180	2011071402	2020.05.12
DC Power Source	N/A	PS-6005D	20170402923	2020.05.12

4. OUTPUT POWER

4.1 OUTPUT POWER MEASUREMENT

LTE Measurement Procedure:

All LTE bands conducted power peak and average are obtained from the CMW500 telecommunication test set. The following tests were conducted according to the test requirements outlined in section 6.2 of the 3GPP TS36.101 specification.

UE Power Class: 3 (23 +/- 2dBm). The allowed Maximum Power Reduction (MPR) for the maximum output power due to higher order modulation and transmit bandwidth configuration (resource blocks) is specified in Table 6.2.3-1 of the 3GPP TS36.101.

Table 6.2.3-1: Maximum Power Reduction (MPR) for Power Class 3

Modulation	Channel bandwidth / Transmission bandwidth (RB)						MPR (dB)
	1.4 MHz	3.0 MHz	5 MHz	10 MHz	15 MHz	20 MHz	
QPSK	> 5	> 4	> 8	> 12	> 16	> 18	≤ 1
16 QAM	≤ 5	≤ 4	≤ 8	≤ 12	≤ 16	≤ 18	≤ 1
16 QAM	> 5	> 4	> 8	> 12	> 16	> 18	≤ 2

The allowed A-MPR values specified below in Table 6.2.4.-1 of 3GPP TS36.101 are in addition to the allowed MPR requirements. All the measurements below were performed with A-MPR disabled, by using Network Signaling Value of "NS_01".3

Table 6.2.4-1: Additional Maximum Power Reduction (A-MPR)

Network Signalling value	Requirements (sub-clause)	E-UTRA Band	Channel bandwidth (MHz)	Resources Blocks (N_{RB})	A-MPR (dB)
NS_01	6.6.2.1.1	Table 5.5-1	1.4, 3, 5, 10, 15, 20	Table 5.6-1	NA
NS_03	6.6.2.2.1	2, 4, 10, 23, 25, 35, 36	3	>5	≤ 1
			5	>6	≤ 1
			10	>6	≤ 1
			15	>8	≤ 1
			20	>10	≤ 1
NS_04	6.6.2.2.2	41	5	>6	≤ 1
			10, 15, 20	See Table 6.2.4-4	
NS_05	6.6.3.3.1	1	10, 15, 20	≥ 50	≤ 1
NS_06	6.6.2.2.3	12, 13, 14, 17	1.4, 3, 5, 10	Table 5.6-1	n/a
NS_07	6.6.2.2.3	13	10	Table 6.2.4-2	Table 6.2.4-2
	6.6.3.3.2				
NS_08	6.6.3.3.3	19	10, 15	> 44	≤ 3
NS_09	6.6.3.3.4	21	10, 15	> 40	≤ 1
				> 55	≤ 2
NS_10		20	15, 20	Table 6.2.4-3	Table 6.2.4-3
NS_11	6.6.2.2.1	23 ¹	1.4, 3, 5, 10	Table 6.2.4-5	Table 6.2.4-5
..					
NS_32	-	-	-	-	-

Note 1: Applies to the lower block of Band 23, i.e. a carrier placed in the 2000-2010 MHz region.

Test data reference attachment.

5. OCCUPIED BANDWIDTH

RULE PART(S)

FCC: §2.1049

LIMITS

For reporting purposes only

TEST PROCEDURE

The transmitter output was connected to a calibrated coaxial cable and coupler, the other end of which was connected to a spectrum analyzer. The occupied bandwidth was measured with the spectrum analyzer at the low, middle and high channel in each band. The -26dB bandwidth was also measured and recorded.

MODES TESTED

- LTE Band 2
- LTE Band 4
- LTE Band 5
- LTE Band 7
- LTE Band 12
- LTE Band 17

RESULTS

PASS

Test data reference attachment.

6. BANDEDGE AND EMISSION MASK

RULE PART(S)

FCC: §2.1051, §22.901, §22.917, §24.238, §27.53, and §90.691

FCC: §22.359

LIMITS

FCC: §22.359, §24.238,

The power of any emission outside of the authorized operating frequency ranges must be attenuated below the transmitting power (P) by a factor of at least $43 + 10 \log (P)$ dB.

(m)(4) For mobile digital stations, the attenuation factor shall be not less than $40 + 10 \log (P)$ dB on all frequencies between the channel edge and 5 megahertz from the channel edge, $43 + 10 \log (P)$ dB on all frequencies between 5 megahertz and X megahertz from the channel edge, and $55 + 10 \log (P)$ dB on all frequencies more than X megahertz from the channel edge, where X is the greater of 6 megahertz or the actual emission bandwidth as defined in paragraph (m)(6) of this section. In addition, the attenuation factor shall not be less that $43 + 10 \log (P)$ dB on all frequencies between 2490.5 MHz and 2496 MHz and $55 + 10 \log (P)$ dB at or below 2490.5 MHz. Mobile Satellite Service licensees operating on frequencies below 2495 MHz may also submit a documented interference complaint against BRS licensees operating on channel BRS Channel 1 on the same terms and conditions as adjacent channel BRS or EBS licensees. Show citation box.

TEST PROCEDURE

The transmitter output was connected to a CMW500 Test Set and configured to operate at maximum power. The band edge emissions were measured at the required operating frequencies in each band on the Spectrum Analyzer.

For each band edge measurement:

Set the spectrum analyzer span to include the block edge frequency (704, 716, 824, 849, 1710 and 1755, 1850 and 1910MHz)

Set a marker to point the corresponding band edge frequency in each test case.

MODES TESTED

- LTE Band 2
- LTE Band 4
- LTE Band 5
- LTE Band 7
- LTE Band 12
- LTE Band 17

RESULTS

Test data reference attachment.

Attach only the worst mode QPSK in the attachment

7. OUT OF BAND EMISSIONS

RULE PART(S)

FCC: §2.1051, §22.901, §22.917, §24.238 and §27.53

LIMITS

The power of any emission outside of the authorized operating frequency ranges must be attenuated below the transmitting power (P) by a factor of at least $43 + 10 \log (P)$ dB.

TEST PROCEDURE

The RF output of the transmitter was connected to a spectrum analyzer through a calibrated coaxial cable. Sufficient scans were taken to show the out-of-band Emissions, if any, up to 10th harmonic. Multiple sweeps were recorded in maximum hold mode using a peak detector to ensure that the worst-case emissions were caught.

For each out of band emissions measurement:

Set RBW & VBW to 100 kHz for the measurement below 1 GHz, and 1 MHz for the measurement above 1 GHz.

MODES TESTED

- LTE Band 2
- LTE Band 4
- LTE Band 5
- LTE Band 7
- LTE Band 12
- LTE Band 17

7.1 MEASUREMENT METHOD

The test set up and general procedure is similar to conducted peak output power test. Only different for setting the measurement configuration of the measuring instrument of Spectrum Analyzer.

Test data reference attachment.

Attach only the worst mode QPSK in the attachment

8. RADIATED MEASUREMENT

8.1. RADIATED POWER (ERP & EIRP)

RULE PART(S)

FCC: §2.1046, §22.913, §24.232 and §27.50

LIMITS:

22.913(a) - The ERP of mobile transmitters and auxiliary test transmitters must not exceed 7 Watts.

27.50 (c) (10) the following power and antenna height requirements apply to stations transmitting in the 698–746 MHz band, the portable stations (hand-held devices) are limited to 3 watts ERP.

27.50 (b)(10) Portable stations (hand-held devices) transmitting in the 746–757 MHz, 758–763 MHz, 776–793 MHz, and 805–806 MHz bands are limited to 3 watts ERP.

27.50 (d)(4) The following power and antenna height requirements apply to stations transmitting in the 1710–1755 MHz and 2110–2155 MHz bands: Fixed, mobile, and portable (hand-held) stations operating in the 1710–1755 MHz band are limited to 1 watt EIRP.

TEST PROCEDURE

ANSI/TIA-603-E Clause 2.2.17

KDB 971168 v02r01 RF power output using broadband peak and average power meter method.

KDB 971168 D01 Power Meas License Digital Systems v02r01, “Measurement Guidance for Certification of Licensed Digital Transmitters”

MODES TESTED

LTE Band 2
LTE Band 4
LTE Band 5
LTE Band 7
LTE Band 12
LTE Band 17

RESULTS

Pass

8.2 LTE BAND 2

Radiated Power (EIRP) for Band 2										
Mode	RB/RB SIZE	Frequency	Result						Polarization Of Max. ERP	Conclusion
			SG Level (dBm)	Cable Loss (dBm)	Antenna Gain (dB)	Max. EIRP Average (dBm)	Max. EIRP Average (mW)			
1.4MHz Band QPSK	6/0	1850.7	0.25	3.76	28.24	24.73	297.213	Horizontal	Pass	
		1880	0.58	3.91	28.22	24.89	308.074	Horizontal	Pass	
		1909.3	0.52	3.93	28.20	24.79	301.461	Horizontal	Pass	
3.0MHz Band QPSK	15/0	1851.5	0.23	3.77	28.23	24.69	294.594	Horizontal	Pass	
		1880	0.39	3.91	28.24	24.72	296.493	Horizontal	Pass	
		1908.5	0.51	3.94	28.25	24.82	303.488	Horizontal	Pass	
5.0MHz Band QPSK	25/0	1852.5	0.15	3.77	28.31	24.69	294.268	Horizontal	Pass	
		1880	0.43	3.91	28.22	24.74	297.820	Horizontal	Pass	
		1907.5	0.19	3.94	28.20	24.45	278.470	Horizontal	Pass	
10.0MHz Band QPSK	50/0	1855	0.19	3.79	28.33	24.73	297.418	Horizontal	Pass	
		1880	0.51	3.95	28.22	24.78	300.705	Horizontal	Pass	
		1905	0.62	3.97	28.19	24.84	304.789	Horizontal	Pass	
15.0MHz Band QPSK	75/0	1857.5	0.40	3.79	28.34	24.95	312.295	Horizontal	Pass	
		1880	0.67	3.95	28.22	24.94	311.571	Horizontal	Pass	
		1902.5	0.64	3.97	28.18	24.85	305.409	Horizontal	Pass	
20.0MHz Band QPSK	100/0	1860	0.16	3.81	28.35	24.70	295.345	Horizontal	Pass	
		1880	0.48	3.96	28.22	24.74	297.542	Horizontal	Pass	
		1900	0.73	4.00	28.16	24.89	308.050	Horizontal	Pass	
1.4MHz Band QPSK	6/0	1850.7	0.20	3.76	28.24	24.68	293.846	Vertical	Pass	
		1880	0.47	3.91	28.22	24.78	300.594	Vertical	Pass	
		1909.3	0.35	3.93	28.20	24.62	289.770	Vertical	Pass	
3.0MHz Band QPSK	15/0	1851.5	0.42	3.77	28.23	24.88	307.474	Vertical	Pass	
		1880	0.57	3.91	28.24	24.90	309.130	Vertical	Pass	
		1908.5	0.51	3.94	28.25	24.82	303.159	Vertical	Pass	
5.0MHz Band QPSK	25/0	1852.5	0.15	3.77	28.31	24.69	294.455	Vertical	Pass	
		1880	0.48	3.91	28.22	24.79	301.320	Vertical	Pass	
		1907.5	0.28	3.94	28.20	24.54	284.525	Vertical	Pass	
10.0MHz Band QPSK	50/0	1855	0.28	3.79	28.33	24.82	303.659	Vertical	Pass	
		1880	0.42	3.95	28.22	24.69	294.314	Vertical	Pass	

QPSK		1905	0.30	3.97	28.19	24.52	282.846	Vertical	Pass
15.0MHz z Band QPSK	75/0	1857.5	0.28	3.79	28.34	24.83	303.933	Vertical	Pass
		1880	0.43	3.95	28.22	24.70	295.135	Vertical	Pass
		1902.5	0.73	3.97	28.18	24.94	311.623	Vertical	Pass
20.0MHz z Band QPSK	100/0	1860	0.18	3.81	28.35	24.72	296.679	Vertical	Pass
		1880	0.42	3.96	28.22	24.68	293.612	Vertical	Pass
		1900	0.80	4.00	28.16	24.96	313.128	Vertical	Pass

Note:

SG Level= Signal generator output

Max. EIRP Average (dBm)= Antenna Gain(dB)+ SG Level (dBm)- Cable Loss(dBm)

Radiated Power (EIRP) for Band 2									
Mode	RB/RB SIZE	Frequency	Result					Polarization Of Max. ERP	Conclusion
			SG Level (dBm)	Cable Loss (dBm)	Antenna Gain (dB)	Max. EIRP Average (dBm)	Max. EIRP		
							Average (mW)		
1.4MHz Band 16 QAM	6/0	1850.7	-0.65	3.76	28.24	23.83	241.783	Horizontal	Pass
		1880	-0.49	3.91	28.22	23.82	241.219	Horizontal	Pass
		1909.3	-0.34	3.93	28.20	23.93	247.387	Horizontal	Pass
3.0MHz Band 16 QAM	15/0	1851.5	-0.55	3.77	28.23	23.91	245.978	Horizontal	Pass
		1880	-0.52	3.91	28.24	23.81	240.414	Horizontal	Pass
		1908.5	-0.55	3.94	28.25	23.76	237.909	Horizontal	Pass
5.0MHz Band 16 QAM	25/0	1852.5	-0.70	3.77	28.31	23.84	242.131	Horizontal	Pass
		1880	-0.40	3.91	28.22	23.91	245.942	Horizontal	Pass
		1907.5	-0.42	3.94	28.20	23.84	242.028	Horizontal	Pass
10.0MHz z Band 16 QAM	50/0	1855	-0.61	3.79	28.33	23.93	247.138	Horizontal	Pass
		1880	-0.38	3.95	28.22	23.89	245.010	Horizontal	Pass
		1905	-0.30	3.97	28.19	23.92	246.796	Horizontal	Pass
15.0MHz z Band 16 QAM	75/0	1857.5	-0.75	3.79	28.34	23.80	240.032	Horizontal	Pass
		1880	-0.48	3.95	28.22	23.79	239.240	Horizontal	Pass
		1902.5	-0.44	3.97	28.18	23.77	238.480	Horizontal	Pass
20.0MHz z Band 16 QAM	100/0	1860	-0.72	3.81	28.35	23.82	241.188	Horizontal	Pass
		1880	-0.23	3.96	28.22	24.03	252.998	Horizontal	Pass
		1900	-0.45	4.00	28.16	23.71	235.022	Horizontal	Pass
1.4MHz Band 16 QAM	6/0	1850.7	-0.62	3.76	28.24	23.86	243.308	Vertical	Pass
		1880	-0.58	3.91	28.22	23.73	236.201	Vertical	Pass
		1909.3	-0.36	3.93	28.20	23.91	245.842	Vertical	Pass
3.0MHz Band 16 QAM	15/0	1851.5	-0.65	3.77	28.23	23.81	240.490	Vertical	Pass
		1880	-0.61	3.91	28.24	23.72	235.378	Vertical	Pass
		1908.5	-0.42	3.94	28.25	23.89	244.714	Vertical	Pass
5.0MHz Band 16 QAM	25/0	1852.5	-0.75	3.77	28.31	23.79	239.598	Vertical	Pass
		1880	-0.58	3.91	28.22	23.73	236.077	Vertical	Pass
		1907.5	-0.34	3.94	28.20	23.92	246.574	Vertical	Pass
10.0MHz z Band 16 QAM	50/0	1855	-0.85	3.79	28.33	23.69	234.034	Vertical	Pass
		1880	-0.59	3.95	28.22	23.68	233.107	Vertical	Pass
		1905	-0.59	3.97	28.19	23.63	230.471	Vertical	Pass
15.0MHz z Band	75/0	1857.5	-0.84	3.79	28.34	23.71	235.061	Vertical	Pass
		1880	-0.57	3.95	28.22	23.70	234.263	Vertical	Pass

16 QAM		1902.5	-0.57	3.97	28.18	23.64	231.336	Vertical	Pass
20.0MH	100/0	1860	-0.75	3.81	28.35	23.79	239.466	Vertical	Pass
z Band		1880	-0.16	3.96	28.22	24.10	257.307	Vertical	Pass
16 QAM		1900	-0.33	4.00	28.16	23.83	241.381	Vertical	Pass

Note:

SG Level= Signal generator output

Max. EIRP Average (dBm)= Antenna Gain(dB)+ SG Level (dBm)- Cable Loss(dBm)

8.3 LTE BAND 4

Radiated Power (EIRP) for Band 4										
Mode	RB/RB SIZE	Frequency	Result						Polarization Of Max. ERP	Conclusion
			SG Level (dBm)	Cable Loss (dBm)	Antenna Gain (dB)	Max. EIRP Average (dBm)	Max. EIRP Average (mW)			
1.4MHz Band QPSK	6/0	1710.7	0.30	3.12	27.58	24.76	298.994	Horizontal	Pass	
		1732.5	0.24	3.27	27.61	24.58	287.367	Horizontal	Pass	
		1754.3	0.53	3.29	27.63	24.87	306.795	Horizontal	Pass	
3.0MHz Band QPSK	15/0	1711.5	0.08	3.13	27.61	24.56	286.082	Horizontal	Pass	
		1732.5	0.33	3.27	27.61	24.67	293.333	Horizontal	Pass	
		1753.5	0.43	3.30	27.62	24.75	298.640	Horizontal	Pass	
5.0MHz Band QPSK	25/0	1712.5	0.43	3.13	27.63	24.93	311.420	Horizontal	Pass	
		1732.5	-0.20	3.27	27.61	24.14	259.419	Horizontal	Pass	
		1752.5	0.76	3.30	27.60	25.06	320.514	Horizontal	Pass	
10.0MHz Band QPSK	50/0	1715	0.42	3.15	27.64	24.91	309.650	Horizontal	Pass	
		1732.5	0.59	3.31	27.61	24.89	308.043	Horizontal	Pass	
		1750	0.59	3.33	27.59	24.85	305.467	Horizontal	Pass	
15.0MHz Band QPSK	75/0	1717.5	0.15	3.15	27.65	24.65	291.991	Horizontal	Pass	
		1732.5	0.65	3.31	27.61	24.95	312.572	Horizontal	Pass	
		1747.5	0.51	3.33	27.57	24.75	298.685	Horizontal	Pass	
20.0MHz Band QPSK	100/0	1720	0.27	3.17	27.66	24.76	299.452	Horizontal	Pass	
		1732.5	0.59	3.32	27.61	24.88	307.424	Horizontal	Pass	
		1745	0.35	3.36	27.56	24.55	285.186	Horizontal	Pass	
1.4MHz Band QPSK	6/0	1710.7	0.36	3.12	27.58	24.82	303.234	Vertical	Pass	
		1732.5	0.48	3.27	27.61	24.82	303.534	Vertical	Pass	
		1754.3	0.51	3.29	27.63	24.85	305.521	Vertical	Pass	
3.0MHz Band QPSK	15/0	1711.5	0.38	3.13	27.61	24.86	306.517	Vertical	Pass	
		1732.5	0.50	3.27	27.61	24.84	304.784	Vertical	Pass	
		1753.5	0.47	3.30	27.62	24.79	301.624	Vertical	Pass	
5.0MHz Band QPSK	25/0	1712.5	-0.45	3.13	27.63	24.05	253.909	Vertical	Pass	
		1732.5	-0.24	3.27	27.61	24.10	257.064	Vertical	Pass	
		1752.5	-0.12	3.30	27.60	24.18	262.012	Vertical	Pass	
10.0MHz Band QPSK	50/0	1715	0.32	3.15	27.64	24.81	303.013	Vertical	Pass	
		1732.5	0.55	3.31	27.61	24.85	305.726	Vertical	Pass	
		1750	0.63	3.33	27.59	24.89	308.503	Vertical	Pass	

15.0MH z Band QPSK	75/0	1717.5	0.27	3.15	27.65	24.77	300.247	Vertical	Pass
		1732.5	0.64	3.31	27.61	24.94	312.117	Vertical	Pass
		1747.5	0.63	3.33	27.57	24.87	306.665	Vertical	Pass
20.0MH z Band QPSK	100/0	1720	0.57	3.17	27.66	25.06	320.786	Vertical	Pass
		1732.5	0.57	3.32	27.61	24.86	306.503	Vertical	Pass
		1745	0.51	3.36	27.56	24.71	296.003	Vertical	Pass

Note:

SG Level= Signal generator output

Max. EIRP Average (dBm)= Antenna Gain(dB)+ SG Level (dBm)- Cable Loss(dBm)

Radiated Power (EIRP) for Band 4									
Mode	RB/RB SIZE	Frequency	Result						Conclusion
			SG Level (dBm)	Cable Loss (dBm)	Antenna Gain (dB)	Max. EIRP	Max. EIRP	Polarization Of Max. ERP	
						Average (dBm)	Average (mW)		
1.4MHz Band 16 QAM	6/0	1710.7	-0.58	3.12	27.58	23.88	244.067	Horizontal	Pass
		1732.5	-0.41	3.27	27.61	23.93	247.192	Horizontal	Pass
		1754.3	-0.56	3.29	27.63	23.78	238.981	Horizontal	Pass
3.0MHz Band 16 QAM	15/0	1711.5	-1.38	3.13	27.61	23.10	204.265	Horizontal	Pass
		1732.5	-1.15	3.27	27.61	23.19	208.310	Horizontal	Pass
		1753.5	-1.12	3.30	27.62	23.20	208.736	Horizontal	Pass
5.0MHz Band 16 QAM	25/0	1712.5	-1.53	3.13	27.63	22.97	198.093	Horizontal	Pass
		1732.5	-1.36	3.27	27.61	22.98	198.782	Horizontal	Pass
		1752.5	-0.31	3.30	27.60	23.99	250.444	Horizontal	Pass
10.0MHz Band 16 QAM	50/0	1715	-0.72	3.15	27.64	23.77	238.041	Horizontal	Pass
		1732.5	-0.43	3.31	27.61	23.87	243.966	Horizontal	Pass
		1750	-0.69	3.33	27.59	23.57	227.356	Horizontal	Pass
15.0MHz Band 16 QAM	75/0	1717.5	-0.44	3.15	27.65	24.06	254.651	Horizontal	Pass
		1732.5	-0.32	3.31	27.61	23.98	249.799	Horizontal	Pass
		1747.5	-0.32	3.33	27.57	23.92	246.668	Horizontal	Pass
20.0MHz Band 16 QAM	100/0	1720	-0.73	3.17	27.66	23.76	237.830	Horizontal	Pass
		1732.5	-0.59	3.32	27.61	23.70	234.580	Horizontal	Pass
		1745	-0.32	3.36	27.56	23.88	244.439	Horizontal	Pass
1.4MHz Band 16 QAM	6/0	1710.7	-0.46	3.12	27.58	24.00	251.340	Vertical	Pass
		1732.5	-0.45	3.27	27.61	23.89	244.638	Vertical	Pass
		1754.3	-0.42	3.29	27.63	23.92	246.383	Vertical	Pass
3.0MHz Band 16 QAM	15/0	1711.5	-1.22	3.13	27.61	23.26	211.846	Vertical	Pass
		1732.5	-1.15	3.27	27.61	23.19	208.658	Vertical	Pass
		1753.5	-1.05	3.30	27.62	23.27	212.310	Vertical	Pass
5.0MHz Band 16 QAM	25/0	1712.5	-1.48	3.13	27.63	23.02	200.605	Vertical	Pass
		1732.5	-1.10	3.27	27.61	23.24	210.752	Vertical	Pass
		1752.5	-1.31	3.30	27.60	22.99	199.113	Vertical	Pass
10.0MHz Band 16 QAM	50/0	1715	-0.49	3.15	27.64	24.00	251.441	Vertical	Pass
		1732.5	-0.30	3.31	27.61	24.00	251.242	Vertical	Pass
		1750	-0.51	3.33	27.59	23.75	237.207	Vertical	Pass
15.0MHz Band	75/0	1717.5	-0.79	3.15	27.65	23.71	235.094	Vertical	Pass
		1732.5	-0.62	3.31	27.61	23.68	233.606	Vertical	Pass

16 QAM		1747.5	-0.58	3.33	27.57	23.66	232.253	Vertical	Pass
20.0MH	100/0	1720	-0.63	3.17	27.66	23.86	243.052	Vertical	Pass
z Band		1732.5	-0.55	3.32	27.61	23.74	236.474	Vertical	Pass
16 QAM		1745	-0.09	3.36	27.56	24.11	257.482	Vertical	Pass

Note:

SG Level= Signal generator output

Max. EIRP Average (dBm)= Antenna Gain(dB)+ SG Level (dBm)- Cable Loss(dBm)

8.4 LTE BAND 5

Radiated Power (ERP) for Band 5											
Mode	RB/ RB SIZE	Freque ncy	Result							Polarizati on Of Max. ERP	Conclu sion
			SG Level (dBm)	Cable Loss (dBm)	Anten na Gain (dB)	Corre ction (dB)	Max. ERP Averag e (dBm)	Max. ERP Averag e (mW)			
1.4MHz Band QPSK	6/0	824.7	5.16	2.01	19.68	2.15	20.68	116.972	Horizontal	Pass	
		836.5	5.11	2.01	19.77	2.15	20.72	118.134	Horizontal	Pass	
		848.3	5.05	2.02	19.82	2.15	20.70	117.495	Horizontal	Pass	
3.0MHz Band QPSK	15/0	825.5	5.23	2.01	19.70	2.15	20.77	119.263	Horizontal	Pass	
		836.5	5.07	2.01	19.77	2.15	20.68	116.969	Horizontal	Pass	
		847.5	5.02	2.02	19.81	2.15	20.66	116.386	Horizontal	Pass	
5.0MHz Band QPSK	25/0	826.5	5.09	2.01	19.71	2.15	20.64	115.821	Horizontal	Pass	
		836.5	4.95	2.01	19.77	2.15	20.56	113.707	Horizontal	Pass	
		846.5	4.95	2.02	19.79	2.15	20.57	113.988	Horizontal	Pass	
10.0MHz z Band QPSK	50/0	829	4.90	2.01	19.73	2.15	20.47	111.494	Horizontal	Pass	
		836.5	4.91	2.01	19.77	2.15	20.52	112.793	Horizontal	Pass	
		844	4.98	2.02	19.78	2.15	20.59	114.433	Horizontal	Pass	
1.4MHz Band QPSK	6/0	824.7	5.25	2.01	19.68	2.15	20.77	119.477	Vertical	Pass	
		836.5	5.17	2.01	19.77	2.15	20.78	119.704	Vertical	Pass	
		848.3	5.06	2.02	19.82	2.15	20.71	117.792	Vertical	Pass	
3.0MHz Band QPSK	15/0	825.5	5.27	2.01	19.70	2.15	20.81	120.520	Vertical	Pass	
		836.5	4.99	2.01	19.77	2.15	20.60	114.838	Vertical	Pass	
		847.5	5.00	2.02	19.81	2.15	20.64	115.921	Vertical	Pass	
5.0MHz Band QPSK	25/0	826.5	4.88	2.01	19.71	2.15	20.43	110.327	Vertical	Pass	
		836.5	4.73	2.01	19.77	2.15	20.34	108.118	Vertical	Pass	
		846.5	5.07	2.02	19.79	2.15	20.69	117.189	Vertical	Pass	
10.0MHz z Band QPSK	50/0	829	5.10	2.01	19.73	2.15	20.67	116.578	Vertical	Pass	
		836.5	4.93	2.01	19.77	2.15	20.54	113.222	Vertical	Pass	
		844	5.35	2.02	19.78	2.15	20.96	124.615	Vertical	Pass	

Note:

SG Level= Signal generator output

Max. EIRP Average (dBm)= Antenna Gain(dB)+ SG Level (dBm)- Cable Loss(dBm)

Radiated Power (ERP) for Band 5											
Mode	RB/ RB SIZE	Freque ncy	Result							Polarizati on Of Max. ERP	Conclu sion
			SG Level	Cable Loss (dBm)	Anten na Gain (dB)	Corre ction (dB)	Max. ERP	Max. ERP			
			(dBm)				Averag e	Averag e			
							(dBm)	(mW)			
1.4MHz Band 16 QAM	6/0	824.7	4.03	2.01	19.68	2.15	19.55	90.216	Horizontal	Pass	
		836.5	4.10	2.01	19.77	2.15	19.71	93.627	Horizontal	Pass	
		848.3	4.09	2.02	19.82	2.15	19.74	94.233	Horizontal	Pass	
3.0MHz Band 16 QAM	15/0	825.5	4.27	2.01	19.70	2.15	19.81	95.675	Horizontal	Pass	
		836.5	4.17	2.01	19.77	2.15	19.78	95.121	Horizontal	Pass	
		847.5	3.95	2.02	19.81	2.15	19.59	90.892	Horizontal	Pass	
5.0MHz Band 16 QAM	25/0	826.5	4.17	2.01	19.71	2.15	19.72	93.740	Horizontal	Pass	
		836.5	4.07	2.01	19.77	2.15	19.68	92.835	Horizontal	Pass	
		846.5	4.03	2.02	19.79	2.15	19.65	92.194	Horizontal	Pass	
10.0MH z Band 16 QAM	50/0	829	4.32	2.01	19.73	2.15	19.89	97.477	Horizontal	Pass	
		836.5	4.15	2.01	19.77	2.15	19.76	94.707	Horizontal	Pass	
		844	4.15	2.02	19.78	2.15	19.76	94.574	Horizontal	Pass	
1.4MHz Band 16 QAM	6/0	824.7	4.22	2.01	19.68	2.15	19.74	94.222	Vertical	Pass	
		836.5	4.06	2.01	19.77	2.15	19.67	92.764	Vertical	Pass	
		848.3	4.17	2.02	19.82	2.15	19.82	95.965	Vertical	Pass	
3.0MHz Band 16 QAM	15/0	825.5	4.20	2.01	19.70	2.15	19.74	94.289	Vertical	Pass	
		836.5	4.04	2.01	19.77	2.15	19.65	92.306	Vertical	Pass	
		847.5	3.97	2.02	19.81	2.15	19.61	91.315	Vertical	Pass	
5.0MHz Band 16 QAM	25/0	826.5	4.22	2.01	19.71	2.15	19.77	94.834	Vertical	Pass	
		836.5	4.16	2.01	19.77	2.15	19.77	94.846	Vertical	Pass	
		846.5	4.07	2.02	19.79	2.15	19.69	93.155	Vertical	Pass	
10.0MH z Band 16 QAM	50/0	829	4.34	2.01	19.73	2.15	19.91	97.861	Vertical	Pass	
		836.5	4.21	2.01	19.77	2.15	19.82	95.975	Vertical	Pass	
		844	4.20	2.02	19.78	2.15	19.81	95.819	Vertical	Pass	

Note:

SG Level= Signal generator output

Max. EIRP Average (dBm)= Antenna Gain(dB)+ SG Level (dBm)- Cable Loss(dBm)

8.5 LTE BAND 7

Radiated Power (EIRP) for Band 7										
Mode	RB/ RB SIZE	Frequency	Result						Polarization Of Max. ERP	Conclusion
			SG Level	Cable Loss	Antenna Gain	Max. EIRP	Max. EIRP			
			(dBm)	(dBm)	(dB)	Average (dBm)	Average (mW)			
5.0MHz Band QPSK	25/0	2502.5	2.63	4.54	27.75	25.84	384.070	Horizontal	Pass	
		2535	2.75	4.69	27.72	25.78	378.283	Horizontal	Pass	
		2567.5	2.86	4.71	27.71	25.86	385.615	Horizontal	Pass	
5.0MHz Band 16 QAM	25/0	2502.5	2.57	4.55	27.76	25.78	378.567	Horizontal	Pass	
		2535	2.87	4.69	27.72	25.90	389.032	Horizontal	Pass	
		2567.5	2.83	4.72	27.70	25.81	380.830	Horizontal	Pass	
10.0MHz z Band QPSK	50/0	2505	2.62	4.55	27.77	25.84	383.401	Horizontal	Pass	
		2535	2.81	4.69	27.72	25.84	383.520	Horizontal	Pass	
		2565	2.95	4.72	27.69	25.92	390.665	Horizontal	Pass	
10.0MHz z Band 16 QAM	50/0	2505	2.52	4.57	27.78	25.73	373.960	Horizontal	Pass	
		2535	2.40	4.73	27.72	25.39	346.256	Horizontal	Pass	
		2565	2.74	4.75	27.68	25.67	368.703	Horizontal	Pass	
15.0MHz z Band QPSK	75/0	2507.5	2.41	4.54	27.75	25.62	364.494	Vertical	Pass	
		2535	2.89	4.69	27.72	25.92	391.115	Vertical	Pass	
		2562.5	2.74	4.71	27.71	25.74	374.675	Vertical	Pass	
15.0MHz z Band 16 QAM	75/0	2507.5	2.33	4.55	27.76	25.54	358.478	Vertical	Pass	
		2535	2.83	4.69	27.72	25.86	385.701	Vertical	Pass	
		2562.5	2.56	4.72	27.70	25.54	358.015	Vertical	Pass	
20.0MHz z Band QPSK	100/0	2510	2.61	4.55	27.77	25.83	383.004	Vertical	Pass	
		2535	2.79	4.69	27.72	25.82	382.141	Vertical	Pass	
		2560	2.96	4.72	27.69	25.93	392.042	Vertical	Pass	
20.0MHz z Band 16 QAM	100/0	2510	2.72	4.57	27.78	25.93	392.120	Vertical	Pass	
		2535	2.92	4.73	27.72	25.91	389.803	Vertical	Pass	
		2560	3.01	4.75	27.68	25.94	392.618	Vertical	Pass	

Note:

SG Level= Signal generator output

Max. EIRP Average (dBm)= Antenna Gain(dB)+ SG Level (dBm)- Cable Loss(dBm)

Radiated Power (EIRP) for Band 7										
Mode	RB/ RB SIZE	Frequency	Result						Polarization Of Max. ERP	Conclusion
			SG Level (dBm)	Cable Loss (dBm)	Antenna Gain (dB)	Max. EIRP Average (dBm)	Max. EIRP Average (mW)			
5.0MHz Band QPSK	25/0	2502.5	0.25	4.54	27.75	23.46	221.757	Horizontal	Pass	
		2535	0.40	4.69	27.72	23.43	220.057	Horizontal	Pass	
		2567.5	0.46	4.71	27.71	23.46	221.905	Horizontal	Pass	
5.0MHz Band 16 QAM	25/0	2502.5	0.33	4.55	27.76	23.54	225.705	Horizontal	Pass	
		2535	0.39	4.69	27.72	23.42	219.927	Horizontal	Pass	
		2567.5	0.53	4.72	27.70	23.51	224.618	Horizontal	Pass	
10.0MHz z Band QPSK	50/0	2505	0.43	4.55	27.77	23.65	231.611	Horizontal	Pass	
		2535	0.51	4.69	27.72	23.54	226.066	Horizontal	Pass	
		2565	0.44	4.72	27.69	23.41	219.502	Horizontal	Pass	
10.0MHz z Band 16 QAM	50/0	2505	0.13	4.57	27.78	23.34	215.897	Horizontal	Pass	
		2535	0.47	4.73	27.72	23.46	221.648	Horizontal	Pass	
		2565	0.37	4.75	27.68	23.30	213.976	Horizontal	Pass	
15.0MHz z Band QPSK	75/0	2507.5	0.11	4.54	27.75	23.32	214.849	Vertical	Pass	
		2535	0.23	4.69	27.72	23.26	211.647	Vertical	Pass	
		2562.5	0.30	4.71	27.71	23.30	213.793	Vertical	Pass	
15.0MHz z Band 16 QAM	75/0	2507.5	0.37	4.55	27.76	23.58	228.002	Vertical	Pass	
		2535	0.56	4.69	27.72	23.59	228.482	Vertical	Pass	
		2562.5	0.54	4.72	27.70	23.52	224.791	Vertical	Pass	
20.0MHz z Band QPSK	100/0	2510	0.04	4.55	27.77	23.26	211.642	Vertical	Pass	
		2535	0.30	4.69	27.72	23.33	215.364	Vertical	Pass	
		2560	0.30	4.72	27.69	23.27	212.394	Vertical	Pass	
20.0MHz z Band 16 QAM	100/0	2510	0.42	4.57	27.78	23.63	230.484	Vertical	Pass	
		2535	0.67	4.73	27.72	23.66	232.340	Vertical	Pass	
		2560	0.58	4.75	27.68	23.51	224.493	Vertical	Pass	

Note:

SG Level= Signal generator output

Max. EIRP Average (dBm)= Antenna Gain(dB)+ SG Level (dBm)- Cable Loss(dBm)

8.6 LTE BAND 12

Radiated Power (ERP) for Band 12											
Mode	RB/ RB SIZE	Frequ ncy	Result							Polarizati on Of Max. ERP	Conclu sion
			SG Level (dBm)	Cable Loss (dBm)	Anten na Gain (dB)	Corre ction (dB)	Max. ERP Averag e (dBm)	Max. ERP Averag e (mW)			
1.4MHz Band QPSK	6/0	699.7	5.50	1.91	19.21	2.15	20.65	116.161	Vertical	Pass	
		707.5	5.43	1.91	19.26	2.15	20.63	115.636	Vertical	Pass	
		715.3	5.15	1.93	19.34	2.15	20.41	110.009	Vertical	Pass	
3.0MHz Band QPSK	15/0	700.5	5.11	1.91	19.21	2.15	20.26	106.191	Vertical	Pass	
		707.5	5.28	1.91	19.26	2.15	20.48	111.685	Vertical	Pass	
		714.5	5.18	1.93	19.34	2.15	20.44	110.604	Vertical	Pass	
5.0MHz Band QPSK	25/0	701.5	5.60	1.91	19.23	2.15	20.77	119.386	Vertical	Pass	
		707.5	5.41	1.91	19.26	2.15	20.61	115.108	Vertical	Pass	
		713.5	5.32	1.92	19.33	2.15	20.58	114.176	Vertical	Pass	
10.0MH z Band QPSK	50/0	704	5.21	1.91	19.25	2.15	20.40	109.720	Vertical	Pass	
		707.5	5.24	1.91	19.26	2.15	20.44	110.753	Vertical	Pass	
		711	5.33	1.92	19.32	2.15	20.58	114.221	Vertical	Pass	
1.4MHz Band QPSK	6/0	699.7	5.41	1.91	19.21	2.15	20.56	113.636	Horizontal	Pass	
		707.5	5.29	1.91	19.26	2.15	20.49	111.960	Horizontal	Pass	
		715.3	5.37	1.93	19.34	2.15	20.63	115.552	Horizontal	Pass	
3.0MHz Band QPSK	15/0	700.5	5.55	1.91	19.21	2.15	20.70	117.382	Horizontal	Pass	
		707.5	5.30	1.91	19.26	2.15	20.50	112.101	Horizontal	Pass	
		714.5	5.62	1.93	19.34	2.15	20.88	122.366	Horizontal	Pass	
5.0MHz Band QPSK	25/0	701.5	5.64	1.91	19.23	2.15	20.81	120.373	Horizontal	Pass	
		707.5	5.66	1.91	19.26	2.15	20.86	121.783	Horizontal	Pass	
		713.5	5.20	1.92	19.33	2.15	20.46	111.163	Horizontal	Pass	
10.0MH z Band QPSK	50/0	704	5.42	1.91	19.25	2.15	20.61	115.097	Horizontal	Pass	
		707.5	5.33	1.91	19.26	2.15	20.53	112.953	Horizontal	Pass	
		711	5.64	1.92	19.32	2.15	20.89	122.823	Horizontal	Pass	

Radiated Power (EIRP) for Band 12											
Mode	RB/ RB SIZE	Freque ncy	Result							Polarizati on Of Max. ERP	Conclu sion
			SG Level	Cable Loss (dBm)	Anten na Gain (dB)	Corre ction (dB)	Max. ERP	Max. ERP			
			(dBm)				Averag e	Averag e			
							(dBm)	(mW)			
1.4MHz Band 16 QAM	6/0	699.7	4.24	1.91	19.21	2.15	19.39	86.967	Vertical	Pass	
		707.5	3.95	1.91	19.26	2.15	19.15	82.309	Vertical	Pass	
		715.3	3.85	1.93	19.34	2.15	19.11	81.432	Vertical	Pass	
3.0MHz Band 16 QAM	15/0	700.5	4.51	1.91	19.21	2.15	19.66	92.519	Vertical	Pass	
		707.5	4.34	1.91	19.26	2.15	19.54	89.912	Vertical	Pass	
		714.5	4.52	1.93	19.34	2.15	19.78	95.111	Vertical	Pass	
5.0MHz Band 16 QAM	25/0	701.5	4.45	1.91	19.23	2.15	19.62	91.579	Vertical	Pass	
		707.5	4.58	1.91	19.26	2.15	19.78	95.057	Vertical	Pass	
		713.5	4.30	1.92	19.33	2.15	19.56	90.407	Vertical	Pass	
10.0MH z Band 16 QAM	50/0	704	4.64	1.91	19.25	2.15	19.83	96.161	Vertical	Pass	
		707.5	4.45	1.91	19.26	2.15	19.65	92.163	Vertical	Pass	
		711	4.64	1.92	19.32	2.15	19.89	97.543	Vertical	Pass	
1.4MHz Band 16 QAM	6/0	699.7	4.26	1.91	19.21	2.15	19.41	87.356	Horizontal	Pass	
		707.5	4.18	1.91	19.26	2.15	19.38	86.722	Horizontal	Pass	
		715.3	4.15	1.93	19.34	2.15	19.41	87.285	Horizontal	Pass	
3.0MHz Band 16 QAM	15/0	700.5	4.62	1.91	19.21	2.15	19.77	94.874	Horizontal	Pass	
		707.5	4.56	1.91	19.26	2.15	19.76	94.535	Horizontal	Pass	
		714.5	4.60	1.93	19.34	2.15	19.86	96.938	Horizontal	Pass	
5.0MHz Band 16 QAM	25/0	701.5	4.35	1.91	19.23	2.15	19.52	89.567	Horizontal	Pass	
		707.5	4.58	1.91	19.26	2.15	19.78	95.125	Horizontal	Pass	
		713.5	4.55	1.92	19.33	2.15	19.81	95.719	Horizontal	Pass	
10.0MH z Band 16 QAM	50/0	704	4.78	1.91	19.25	2.15	19.97	99.220	Horizontal	Pass	
		707.5	4.54	1.91	19.26	2.15	19.74	94.142	Horizontal	Pass	
		711	4.59	1.92	19.32	2.15	19.84	96.478	Horizontal	Pass	

Note:

SG Level= Signal generator output

Max. EIRP Average (dBm)= Antenna Gain(dB)+ SG Level (dBm)- Cable Loss(dBm)

8.7 LTE BAND 17

Radiated Power (ERP) for Band 17											
Mode	RB/ RB SIZE	Frequ ncy	Result							Polarizati on Of Max. ERP	Conclu sion
			SG Level (dBm)	Cable Loss (dBm)	Anten na Gain (dB)	Corre ction (dB)	Max. ERP Averag e (dBm)	Max. ERP Averag e (mW)			
			5.0MHz Band QPSK	25/0	706.5	5.75	1.91	19.23	2.15		
		710	5.78	1.91	19.26	2.15	20.98	125.323	Vertical	Pass	
		713.5	5.46	1.92	19.33	2.15	20.72	118.077	Vertical	Pass	
10.0MH z Band QPSK	50/0	709	5.09	1.91	19.25	2.15	20.28	106.745	Vertical	Pass	
		710	5.02	1.91	19.26	2.15	20.22	105.140	Vertical	Pass	
		711	5.62	1.92	19.32	2.15	20.87	122.141	Vertical	Pass	
5.0MHz Band QPSK	25/0	706.5	5.14	1.91	19.23	2.15	20.31	107.304	Horizontal	Pass	
		710	5.67	1.91	19.26	2.15	20.87	122.251	Horizontal	Pass	
		713.5	4.87	1.92	19.33	2.15	20.13	102.925	Horizontal	Pass	
10.0MH z Band QPSK	50/0	709	4.84	1.91	19.25	2.15	20.03	100.743	Horizontal	Pass	
		710	5.75	1.91	19.26	2.15	20.95	124.546	Horizontal	Pass	
		711	5.76	1.92	19.32	2.15	21.01	126.145	Horizontal	Pass	

Radiated Power (ERP) for Band 17											
Mode	RB/ RB SIZE	Freque ncy	Result							Polarizati on Of Max. ERP	Conclu sion
			SG Level (dBm)	Cable Loss (dBm)	Anten na Gain (dB)	Corre ction (dB)	Max. ERP Averag e (dBm)	Max. ERP Averag e (mW)			
5.0MHz Band 16 QAM	25/0	706.5	4.52	1.91	19.23	2.15	19.69	93.017	Vertical	Pass	
		710	4.59	1.91	19.26	2.15	19.79	95.201	Vertical	Pass	
		713.5	4.52	1.92	19.33	2.15	19.78	94.992	Vertical	Pass	
10.0MH z Band 16 QAM	50/0	709	4.39	1.91	19.25	2.15	19.58	90.839	Vertical	Pass	
		710	4.15	1.91	19.26	2.15	19.35	86.103	Vertical	Pass	
		711	4.29	1.92	19.32	2.15	19.54	90.014	Vertical	Pass	
5.0MHz Band 16 QAM	25/0	706.5	4.46	1.91	19.23	2.15	19.63	91.834	Horizontal	Pass	
		710	4.34	1.91	19.26	2.15	19.54	89.995	Horizontal	Pass	
		713.5	4.40	1.92	19.33	2.15	19.66	92.544	Horizontal	Pass	
10.0MH z Band 16 QAM	50/0	709	4.37	1.91	19.25	2.15	19.56	90.394	Horizontal	Pass	
		710	4.66	1.91	19.26	2.15	19.86	96.852	Horizontal	Pass	
		711	4.20	1.92	19.32	2.15	19.45	88.168	Horizontal	Pass	

Note:

SG Level= Signal generator output

Max. EIRP Average (dBm)= Antenna Gain(dB)+ SG Level (dBm)- Cable Loss(dBm)

9. SPURIOUS RADIATION EMISSION

RULE PART(S)

FCC: §2.1053, §22.917, §24.238 and §27.53

LIMIT

§22.917 (e) and §24.238 (a): Out of band emissions. The power of any emission outside of the authorized operating frequency ranges must be attenuated below the transmitting power (P) by a factor of at least $43 + 10 \log (P)$ dB.

§27.53 (g) For operations in the 698–746 MHz band, the power of any emission outside a licensee's frequency band(s) of operation shall be attenuated below the transmitter power (P) within the licensed band(s) of operation, measured in watts, by at least $43 + 10 \log (P)$ dB.

§27.53 (h) For operations in the 1710–1755 MHz and 2110–2155 MHz bands, the power of any emission outside a licensee's frequency block shall be attenuated below the transmitter power (P) by at least $43 + 10 \log_{10}(P)$ dB.

TEST PROCEDURE

For Cellular equipment - Compliance with these rules is based on the use of measurement instrumentation employing a resolution bandwidth of 100 kHz or greater. In the 1 MHz bands immediately outside and adjacent to the frequency block a resolution bandwidth of at least one percent of the emission bandwidth of the fundamental emission of the transmitter may be employed. A narrower resolution bandwidth is permitted in all cases to improve measurement accuracy provided the measured power is integrated over the full required measurement bandwidth (i.e. 100 kHz or 1 percent of emission bandwidth, as specified). The emission bandwidth is defined as the width of the signal between two points, one below the carrier center frequency and one above the carrier center frequency, outside of which all emissions are attenuated at least 26 dB below the transmitter power.

For PCS equipment - Compliance with these rules is based on the use of measurement instrumentation employing a resolution bandwidth of 1 MHz or greater. However, in the 1 MHz bands immediately outside and adjacent to the frequency block a resolution bandwidth of at least one percent of the emission bandwidth of the fundamental emission of the transmitter may be employed. A narrower resolution bandwidth is permitted in all cases to improve measurement accuracy provided the measured power is integrated over the full required measurement bandwidth (i.e. 1 MHz or 1 percent of emission bandwidth, as specified). The emission bandwidth is defined as the width of the signal between two points, one below the carrier center frequency and one above the carrier center frequency, outside of which all emissions are attenuated at least 26 dB below the transmitter power.

The unwanted emission power shall be measured with a resolution bandwidth of at least 1% of the occupied bandwidth in the 1 MHz band immediately outside and adjacent to the channel edge of the equipment. Beyond the 1 MHz band immediately outside the channel edge of the equipment, a resolution bandwidth of 1 MHz shall be employed. A narrower resolution bandwidth is allowed to be used provided that the measured power is integrated over the full required measurement bandwidth of 1 MHz or 1% of the occupied bandwidth as applicable.

The power of any unwanted emissions measured from the channel edge of the equipment shall be attenuated below the transmitter power, P (dBW), as follows:

- a. for base station and subscriber equipment, other than mobile subscriber equipment, the attenuation shall not be less than $43 + 10 \text{ Log}_{10}(p)$, dB; and
- b. for mobile subscriber equipment, the attenuation shall not be less than $43 + 10 \text{ Log}_{10}(p)$, dB at the channel edges and $55 + 10 \text{ Log}_{10}(p)$ at 5.5 MHz away and beyond the channel edges where p in (a) and (b) is the transmitter power measured in watts.

MODES TESTED

- LTE Band 2
- LTE Band 4
- LTE Band 5
- LTE Band 7
- LTE Band 12
- LTE Band 17

RESULTS

PASS

9.1 LTE BAND 2

QPSK EIRP POWER FOR LTE BAND 2 (1.4MHZ BANDWIDTH)

Test Results for Low Channel 1850.7MHz							
Frequency(MHz)	SG Level(dBm)	Cable Loss(dB)	Antenna Gain(dB)	Absolute Level(dBm)	Limit (dBm)	Margin(dBm)	Polarity
3701.4	-51.71	4.04	33.51	-22.24	-13	-9.24	Horizontal
3701.4	-47.50	4.04	33.51	-18.03	-13	-5.03	Vertical
5552.1	-50.49	5.24	35.84	-19.89	-13	-6.89	Vertical
5552.1	-49.42	5.24	35.84	-18.82	-13	-5.82	Horizontal
254.2799397	-69.94	1.54	15.33	-56.15	-13	-43.15	Vertical
177.2287639	-48.70	1.63	15.12	-35.20	-13	-22.20	Horizontal
Test Results for Mid Channel 1880MHz							
3760.0	-48.80	4.04	33.56	-19.28	-13	-6.28	Horizontal
3760.0	-46.08	4.04	33.56	-16.56	-13	-3.56	Vertical
5640.0	-50.27	5.24	35.91	-19.60	-13	-6.60	Vertical
5640.0	-47.17	5.24	35.91	-16.50	-13	-3.50	Horizontal
216.7	-70.36	1.74	15.32	-56.78	-13	-43.78	Vertical
165.1	-48.92	1.71	15.95	-34.68	-13	-21.68	Horizontal
Test Results for High Channel 1909.3MHz							
3818.6	-48.03	4.04	34.00	-18.07	-13	-5.07	Horizontal
3818.6	-47.78	4.04	34.00	-17.82	-13	-4.82	Vertical
5727.9	-47.97	5.24	36.04	-17.17	-13	-4.17	Vertical
5727.9	-47.18	5.24	36.04	-16.38	-13	-3.38	Horizontal
139.3	-57.85	1.58	15.47	-43.96	-13	-30.96	Vertical
241.6	-62.17	1.54	17.12	-46.59	-13	-33.59	Horizontal

QPSK EIRP POWER FOR LTE BAND 2 (20.0MHZ BANDWIDTH)

Test Results for Low Channel 1860MHz							
Frequency(MHz)	SG Level(dBm)	Cable Loss(dB)	Antenna Gain(dB)	Absolute Level(dBm)	Limit (dBm)	Margin(dBm)	Polarity
3720.0	-47.68	4.07	33.54	-18.21	-13	-5.21	Horizontal
3720.0	-47.18	4.07	33.54	-17.71	-13	-4.71	Vertical
5580.0	-52.99	5.28	35.86	-22.41	-13	-9.41	Vertical
5580.0	-49.48	5.28	35.86	-18.90	-13	-5.90	Horizontal
214.4	-49.30	1.33	15.94	-34.69	-13	-21.69	Vertical
110.6	-48.63	1.33	17.13	-32.83	-13	-19.83	Horizontal
Test Results for Mid Channel 1880MHz							
3760.0	-50.05	4.04	33.56	-20.53	-13	-7.53	Horizontal
3760.0	-46.79	4.04	33.56	-17.27	-13	-4.27	Vertical
5640.0	-62.99	5.24	35.91	-32.32	-13	-19.32	Vertical
5640.0	-59.96	5.24	35.91	-29.29	-13	-16.29	Horizontal
266.1	-71.15	1.78	15.26	-57.68	-13	-44.68	Vertical
223.8	-57.05	1.34	16.57	-41.82	-13	-28.82	Horizontal
Test Results for High Channel 1900MHz							
3800.0	-64.64	4.04	34.00	-34.68	-13	-21.68	Horizontal
3800.0	-59.03	4.04	34.00	-29.07	-13	-16.07	Vertical
5700.0	-54.82	5.24	36.04	-24.02	-13	-11.02	Vertical
5700.0	-61.54	5.24	36.04	-30.74	-13	-17.74	Horizontal
186.5	-63.46	1.39	15.32	-49.53	-13	-36.53	Vertical
227.5	-69.87	1.73	17.45	-54.14	-13	-41.14	Horizontal

Note: P_{Mea}(dBm)= Power(dBm)+ ARpl (dBm)
 . Over Limit= : P_{Mea}(dBm)-Limit(dBm)
 . Both QPSK and 16QAM modes have been evaluated, with the worst mode being QPSK.

9.2 LTE BAND 4

QPSK EIRP POWER FOR LTE BAND 4 (1.4MHZ BANDWIDTH)

Test Results for Low Channel 1710.7MHz							
Frequency(MHz)	SG Level(dBm)	Cable Loss(dB)	Antenna Gain(dB)	Absolute Level(dBm)	Limit (dBm)	Margin(dBm)	Polarity
3421.4	-59.93	4.02	29.80	-34.15	-13	-21.15	Horizontal
3421.4	-53.86	4.02	29.80	-28.08	-13	-15.08	Vertical
5132.1	-54.58	5.24	35.84	-23.98	-13	-10.98	Vertical
5132.1	-57.13	5.24	35.84	-26.53	-13	-13.53	Horizontal
99.7	-51.70	1.39	15.65	-37.43	-13	-24.43	Vertical
246.5	-48.06	1.71	16.78	-33.00	-13	-20.00	Horizontal
Test Results for Mid Channel 1732.5MHz							
3465.0	-56.50	4.03	30.00	-30.53	-13	-17.53	Horizontal
3465.0	-56.51	4.03	30.00	-30.54	-13	-17.54	Vertical
5197.5	-60.73	5.25	35.86	-30.12	-13	-17.12	Vertical
5197.5	-58.32	5.25	35.86	-27.71	-13	-14.71	Horizontal
109.8	-68.46	1.45	15.96	-53.95	-13	-40.95	Vertical
276.3	-61.31	1.66	17.56	-45.40	-13	-32.40	Horizontal
Test Results for High Channel 1754.3MHz							
3508.6	-61.77	4.05	30.01	-35.81	-13	-22.81	Horizontal
3508.6	-56.52	4.05	30.01	-30.56	-13	-17.56	Vertical
5262.9	-58.36	5.26	35.86	-27.76	-13	-14.76	Vertical
5262.9	-61.90	5.26	35.86	-31.30	-13	-18.30	Horizontal
276.5	-63.07	1.53	15.98	-48.63	-13	-35.63	Vertical
239.2	-64.44	1.53	16.12	-49.85	-13	-36.85	Horizontal

QPSK EIRP POWER FOR LTE BAND 4 (20.0MHZ BANDWIDTH)

Test Results for Low Channel 1720MHz							
Frequency(MHz)	SG Level(dBm)	Cable Loss(dB)	Antenna Gain(dB)	Absolute Level(dBm)	Limit (dBm)	Margin(dBm)	Polarity
3440.0	-65.50	4.02	29.80	-39.72	-13	-26.72	Horizontal
3440.0	-59.46	4.02	29.80	-33.68	-13	-20.68	Vertical
5160.0	-55.09	5.24	35.84	-24.49	-13	-11.49	Vertical
5160.0	-56.98	5.24	35.84	-26.38	-13	-13.38	Horizontal
94.0	-61.88	1.76	15.63	-48.00	-13	-35.00	Vertical
224.8	-60.64	1.67	15.97	-46.34	-13	-33.34	Horizontal
Test Results for Mid Channel 1732.5MHz							
3465.0	-61.35	4.03	30.00	-35.38	-13	-22.38	Horizontal
3465.0	-59.55	4.03	30.00	-33.58	-13	-20.58	Vertical
5197.5	-58.49	5.25	35.86	-27.88	-13	-14.88	Vertical
5197.5	-54.61	5.25	35.86	-24.00	-13	-11.00	Horizontal
204.6	-60.01	1.39	15.22	-46.18	-13	-33.18	Vertical
250.1	-53.50	1.73	17.80	-37.43	-13	-24.43	Horizontal
Test Results for High Channel 1745MHz							
3490.0	-65.25	2.91	27.68	-40.48	-13	-27.48	Horizontal
3490.0	-59.51	2.91	27.68	-34.74	-13	-21.74	Vertical
5235.0	-60.16	5.26	35.86	-29.56	-13	-16.56	Vertical
5235.0	-55.26	5.26	35.86	-24.66	-13	-11.66	Horizontal
178.8	-63.04	1.44	15.78	-48.70	-13	-35.70	Vertical
268.1	-69.73	1.38	17.31	-53.79	-13	-40.79	Horizontal

Note: P_{Mea}(dBm)= Power(dBm)+ ARpl (dBm)

. Over Limit= : P_{Mea}(dBm)-Limit(dBm)

. Both QPSK and 16QAM modes have been evaluated, with the worst mode being QPSK.

9.3 LTE BAND 5

QPSK EIRP POWER FOR LTE BAND 5 (1.4MHZ BANDWIDTH)

Test Results for Low Channel 824.7MHz							
Frequency(MHz)	SG Level(dBm)	Cable Loss(dB)	Antenna Gain(dB)	Absolute Level(dBm)	Limit (dBm)	Margin(dBm)	Polarity
1649.4	-51.72	2.78	27.50	-27.00	-13	-14.00	Horizontal
1649.4	-49.45	2.78	27.50	-24.73	-13	-11.73	Vertical
2474.1	-47.28	2.90	27.80	-22.38	-13	-9.38	Vertical
2474.1	-47.44	2.90	27.80	-22.54	-13	-9.54	Horizontal
88.6	-64.59	1.41	17.79	-48.21	-13	-35.21	Vertical
195.1	-54.43	1.37	16.63	-39.16	-13	-26.16	Horizontal
Test Results For Mid Channel 836.5MHz							
1673.0	-43.67	2.80	27.48	-18.99	-13	-5.99	Horizontal
1673.0	-43.14	2.80	27.48	-18.46	-13	-5.46	Vertical
2509.5	-51.53	2.91	27.70	-26.74	-13	-13.74	Vertical
2509.5	-47.48	2.91	27.70	-22.69	-13	-9.69	Horizontal
90.6	-48.80	1.34	15.18	-34.95	-13	-21.95	Vertical
268.9	-63.57	1.40	16.14	-48.83	-13	-35.83	Horizontal
Test Results for High Channel 848.3MHz							
1696.6	-43.06	2.82	27.43	-18.45	-13	-5.45	Horizontal
1696.6	-45.20	2.82	27.43	-20.59	-13	-7.59	Vertical
2544.9	-51.13	2.92	27.74	-26.31	-13	-13.31	Vertical
2544.9	-50.42	2.92	27.74	-25.60	-13	-12.60	Horizontal
155.6	-50.62	1.49	17.58	-34.54	-13	-21.54	Vertical
245.0	-69.54	1.69	15.70	-55.52	-13	-42.52	Horizontal

QPSK EIRP POWER FOR LTE BAND 5 (10MHZ BANDWIDTH)

Test Results for Low Channel 829MHz							
Frequency(MHz)	SG Level(dBm)	Cable Loss(dB)	Antenna Gain(dB)	Absolute Level(dBm)	Limit (dBm)	Margin(dBm)	Polarity
1658.0	-51.63	2.78	27.50	-26.91	-13	-13.91	Horizontal
1658.0	-51.26	2.78	27.50	-26.54	-13	-13.54	Vertical
2487.0	-47.88	2.90	27.80	-22.98	-13	-9.98	Vertical
2487.0	-44.15	2.90	27.80	-19.25	-13	-6.25	Horizontal
221.6	-71.72	1.43	16.93	-56.22	-13	-43.22	Vertical
225.6	-63.62	1.53	16.76	-48.39	-13	-35.39	Horizontal
Test Results For Mid Channel 836.5MHz							
1673.0	-55.96	2.80	27.48	-31.28	-13	-18.28	Horizontal
1673.0	-43.65	2.80	27.48	-18.97	-13	-5.97	Vertical
2509.5	-49.30	2.91	27.70	-24.51	-13	-11.51	Vertical
2509.5	-49.81	2.91	27.70	-25.02	-13	-12.02	Horizontal
171.5	-47.36	1.49	17.88	-30.97	-13	-17.97	Vertical
263.1	-64.22	1.40	16.10	-49.53	-13	-36.53	Horizontal
Test Results for High Channel 844MHz							
1688.0	-62.75	2.82	27.43	-38.14	-13	-25.14	Horizontal
1688.0	-55.10	2.82	27.43	-30.49	-13	-17.49	Vertical
2532.0	-54.94	2.92	27.74	-30.12	-13	-17.12	Vertical
2532.0	-56.91	2.92	27.74	-32.09	-13	-19.09	Horizontal
118.4	-65.80	1.55	16.71	-50.64	-13	-37.64	Vertical
240.8	-68.72	1.37	15.22	-54.87	-13	-41.87	Horizontal

Note: P_{Mea}(dBm)= Power(dBm)+ ARpl (dBm)

. Over Limit= : P_{Mea}(dBm)-Limit(dBm)

. Both QPSK and 16QAM modes have been evaluated, with the worst mode being QPSK.

9.4 LTE BAND 7

QPSK EIRP POWER FOR LTE BAND 7 (5.0MHZ BANDWIDTH)

Test Results for Low Channel 2502.5MHz							
Frequency(MHz)	SG Level(dBm)	Cable Loss(dB)	Antenna Gain(dB)	Absolute Level(dBm)	Limit (dBm)	Margin(dBm)	Polarity
5005.0	-79.65	5.23	35.81	-49.07	-25	-24.07	Horizontal
5005.0	-63.65	5.23	35.81	-33.07	-25	-8.07	Vertical
7507.5	-67.14	5.67	36.85	-35.96	-25	-10.96	Vertical
7507.5	-61.58	5.67	36.85	-30.40	-25	-5.40	Horizontal
231.3	-85.57	1.69	17.80	-69.46	-25	-44.46	Vertical
569.4	-74.34	1.59	15.60	-60.34	-25	-35.34	Horizontal
Test Results for Mid Channel 2535MHz							
5070.0	-69.58	5.23	35.82	-38.99	-25	-13.99	Horizontal
5070.0	-65.75	5.23	35.82	-35.16	-25	-10.16	Vertical
7605.0	-69.44	5.67	36.85	-38.26	-25	-13.26	Vertical
7605.0	-83.44	5.67	36.85	-52.26	-25	-27.26	Horizontal
348.2	-62.84	1.66	16.70	-47.80	-25	-22.80	Vertical
482.5	-73.84	1.56	17.49	-57.92	-25	-32.92	Horizontal
Test Results for High Channel 2567.5MHz							
5135.0	-83.65	5.24	35.83	-53.06	-25	-28.06	Horizontal
5135.0	-60.34	5.24	35.83	-29.75	-25	-4.75	Vertical
7702.5	-74.10	5.68	36.87	-42.91	-25	-17.91	Vertical
7702.5	-74.38	5.68	36.87	-43.19	-25	-18.19	Horizontal
270.2	-80.78	1.51	17.13	-65.17	-25	-40.17	Vertical
439.5	-82.38	1.49	17.01	-66.86	-25	-41.86	Horizontal

QPSK EIRP POWER FOR LTE BAND 7 (20.0MHZ BANDWIDTH)

Test Results for Low Channel 2510MHz							
Frequency(MHz)	SG Level(dBm)	Cable Loss(dB)	Antenna Gain(dB)	Absolute Level(dBm)	Limit (dBm)	Margin(dBm)	Polarity
5020.0	-81.59	5.23	35.82	-51.00	-25	-26.00	Horizontal
5020.0	-76.87	5.23	35.82	-46.28	-25	-21.28	Vertical
7530.0	-82.63	5.67	36.86	-51.44	-25	-26.44	Vertical
7530.0	-74.00	5.67	36.86	-42.81	-25	-17.81	Horizontal
267.2	-77.19	1.43	15.00	-63.62	-25	-38.62	Vertical
529.8	-81.12	1.39	17.00	-65.52	-25	-40.52	Horizontal
Test Results for Mid Channel 2535MHz							
5070.0	-78.73	5.23	35.82	-48.14	-25	-23.14	Horizontal
5070.0	-70.18	5.23	35.82	-39.59	-25	-14.59	Vertical
7605.0	-66.20	5.67	36.85	-35.02	-25	-10.02	Vertical
7605.0	-69.22	5.67	36.85	-38.04	-25	-13.04	Horizontal
180.1	-84.10	1.37	15.17	-70.30	-25	-45.30	Vertical
214.3	-64.12	1.70	17.26	-48.57	-25	-23.57	Horizontal
Test Results for High Channel 2560MHz							
5120.0	-62.31	5.24	35.83	-31.72	-25	-6.72	Horizontal
5120.0	-85.69	5.24	35.83	-55.10	-25	-30.10	Vertical
7680.0	-69.45	5.70	36.88	-38.27	-25	-13.27	Vertical
7680.0	-71.44	5.70	36.88	-40.26	-25	-15.26	Horizontal
391.7	-71.94	1.30	17.81	-55.43	-25	-30.43	Vertical
416.9	-80.80	1.66	16.21	-66.25	-25	-41.25	Horizontal

Note: P_{Mea}(dBm)= Power(dBm)+ ARpl (dBm)

. Over Limit= : P_{Mea}(dBm)-Limit(dBm)

. Both QPSK and 16QAM modes have been evaluated, with the worst mode being QPSK.

9.5 LTE BAND 12

QPSK EIRP POWER FOR LTE BAND 12 (1.4MHZ BANDWIDTH)

Test Results for Low Channel 699.7MHz							
Frequency(MHz)	SG Level(dBm)	Cable Loss(dB)	Antenna Gain(dB)	Absolute Level(dBm)	Limit (dBm)	Margin(dBm)	Polarity
1399.4	-65.58	2.60	27.20	-40.98	-13	-27.98	Horizontal
1399.4	-59.40	2.60	27.20	-34.80	-13	-21.80	Vertical
2099.1	-55.32	2.85	27.54	-30.63	-13	-17.63	Vertical
2099.1	-62.66	2.85	27.54	-37.97	-13	-24.97	Horizontal
82.5	-55.54	1.47	16.07	-40.94	-13	-27.94	Vertical
214.5	-51.33	1.78	15.94	-37.17	-13	-24.17	Horizontal
Test Results For Mid Channel 707.5MHz							
1415.0	-53.99	2.61	27.28	-29.32	-13	-16.32	Horizontal
1415.0	-56.94	2.61	27.28	-32.27	-13	-19.27	Vertical
2122.5	-58.69	2.87	27.59	-33.97	-13	-20.97	Vertical
2122.5	-58.77	2.87	27.59	-34.05	-13	-21.05	Horizontal
197.5	-66.93	1.57	16.28	-52.22	-13	-39.22	Vertical
112.5	-67.00	1.46	15.72	-52.74	-13	-39.74	Horizontal
Test Results for High Channel 715.3MHz							
1430.6	-56.00	2.63	27.28	-31.35	-13	-18.35	Horizontal
1430.6	-61.20	2.63	27.28	-36.55	-13	-23.55	Vertical
2145.9	-64.44	2.88	27.60	-39.72	-13	-26.72	Vertical
2145.9	-56.93	2.88	27.60	-32.21	-13	-19.21	Horizontal
240.3	-66.85	1.34	17.07	-51.12	-13	-38.12	Vertical
181.2	-57.47	1.76	17.97	-41.26	-13	-28.26	Horizontal

QPSK EIRP POWER FOR LTE BAND 12 (10MHZ BANDWIDTH)

Test Results for Low Channel 704MHz							
Frequency(MHz)	SG Level(dBm)	Cable Loss(dB)	Antenna Gain(dB)	Absolute Level(dBm)	Limit (dBm)	Margin(dBm)	Polarity
1408.0	-52.80	2.61	27.26	-28.15	-13	-15.15	Horizontal
1408.0	-62.82	2.61	27.26	-38.17	-13	-25.17	Vertical
2112.0	-58.30	2.87	27.58	-33.59	-13	-20.59	Vertical
2112.0	-54.06	2.87	27.58	-29.35	-13	-16.35	Horizontal
104.7	-72.45	1.75	17.21	-56.99	-13	-43.99	Vertical
98.6	-62.48	1.30	17.50	-46.28	-13	-33.28	Horizontal
Test Results for Mid Channel 707.5MHz							
1415.0	-60.95	2.61	27.28	-36.28	-13	-23.28	Horizontal
1415.0	-62.19	2.61	27.28	-37.52	-13	-24.52	Vertical
2122.5	-62.96	2.87	27.59	-38.24	-13	-25.24	Vertical
2122.5	-59.09	2.87	27.59	-34.37	-13	-21.37	Horizontal
103.5	-70.05	1.38	15.38	-56.05	-13	-43.05	Vertical
278.9	-68.84	1.69	17.25	-53.28	-13	-40.28	Horizontal
Test Results for High Channel 711MHz							
1422.0	-54.55	2.62	27.28	-29.89	-13	-16.89	Horizontal
1422.0	-62.96	2.62	27.28	-38.30	-13	-25.30	Vertical
2133.0	-60.44	2.87	27.60	-35.71	-13	-22.71	Vertical
2133.0	-57.80	2.87	27.60	-33.07	-13	-20.07	Horizontal
187.8	-66.41	1.72	17.31	-50.83	-13	-37.83	Vertical
186.5	-57.44	1.78	17.82	-41.40	-13	-28.40	Horizontal

Note: P_{Mea}(dBm)= Power(dBm)+ AR_{pl} (dBm)

. Over Limit= : P_{Mea}(dBm)-Limit(dBm)

. Both QPSK and 16QAM modes have been evaluated, with the worst mode being QPSK.

9.6 LTE BAND 17

QPSK EIRP POWER FOR LTE BAND 17 (5MHZ BANDWIDTH)

Test Results for Low Channel 706.5MHz							
Frequency(MHz)	SG Level(dBm)	Cable Loss(dB)	Antenna Gain(dB)	Absolute Level(dBm)	Limit (dBm)	Margin(dBm)	Polarity
1413.0	-57.33	2.61	27.28	-32.66	-13	-19.66	Horizontal
1413.0	-61.78	2.61	27.28	-37.11	-13	-24.11	Vertical
2119.5	-64.30	2.87	27.59	-39.58	-13	-26.58	Vertical
2119.5	-52.71	2.87	27.59	-27.99	-13	-14.99	Horizontal
87.5	-72.24	1.42	15.39	-58.27	-13	-45.27	Vertical
233.8	-67.76	1.62	16.70	-52.68	-13	-39.68	Horizontal
Test Results For Mid Channel 710MHz							
1420.0	-54.41	2.62	27.30	-29.73	-13	-16.73	Horizontal
1420.0	-64.02	2.62	27.30	-39.34	-13	-26.34	Vertical
2130.0	-62.50	2.87	27.62	-37.75	-13	-24.75	Vertical
2130.0	-59.85	2.87	27.62	-35.10	-13	-22.10	Horizontal
98.0	-70.37	1.53	17.81	-54.09	-13	-41.09	Vertical
224.4	-48.16	1.61	16.11	-33.67	-13	-20.67	Horizontal
Test Results for High Channel 713.5MHz							
1427.0	-62.23	2.66	27.28	-37.61	-13	-24.61	Horizontal
1427.0	-56.29	2.66	27.28	-31.67	-13	-18.67	Vertical
2140.5	-58.42	2.88	27.60	-33.70	-13	-20.70	Vertical
2140.5	-61.53	2.88	27.60	-36.81	-13	-23.81	Horizontal
230.2	-65.96	1.45	17.08	-50.34	-13	-37.34	Vertical
90.2	-56.07	1.68	16.43	-41.32	-13	-28.32	Horizontal

QPSK EIRP POWER FOR LTE BAND 17 (10MHZ BANDWIDTH)

Test Results for Low Channel 709MHz							
Frequency(MHz)	SG Level(dBm)	Cable Loss(dB)	Antenna Gain(dB)	Absolute Level(dBm)	Limit (dBm)	Margin(dBm)	Polarity
1418.0	-53.25	2.62	27.30	-28.57	-13	-15.57	Horizontal
1418.0	-59.76	2.62	27.30	-35.08	-13	-22.08	Vertical
2127.0	-62.77	2.87	27.62	-38.02	-13	-25.02	Vertical
2127.0	-58.77	2.87	27.62	-34.02	-13	-21.02	Horizontal
178.4	-53.57	1.74	16.78	-38.53	-13	-25.53	Vertical
268.6	-67.27	1.53	15.77	-53.03	-13	-40.03	Horizontal
Test Results for Mid Channel 710MHz							
1420.0	-58.47	2.62	27.30	-33.79	-13	-20.79	Horizontal
1420.0	-57.54	2.62	27.30	-32.86	-13	-19.86	Vertical
2130.0	-63.60	2.87	27.62	-38.85	-13	-25.85	Vertical
2130.0	-59.95	2.87	27.62	-35.20	-13	-22.20	Horizontal
202.2	-64.24	1.53	16.81	-48.96	-13	-35.96	Vertical
245.7	-53.09	1.59	17.18	-37.50	-13	-24.50	Horizontal
Test Results for High Channel 711MHz							
1422.0	-58.80	2.62	27.30	-34.12	-13	-21.12	Horizontal
1422.0	-57.49	2.62	27.30	-32.81	-13	-19.81	Vertical
2133.0	-56.57	2.87	27.62	-31.82	-13	-18.82	Vertical
2133.0	-54.01	2.87	27.62	-29.26	-13	-16.26	Horizontal
270.4	-48.29	1.32	15.07	-34.54	-13	-21.54	Vertical
146.0	-67.38	1.69	16.03	-53.04	-13	-40.04	Horizontal

Note: $P_{Mea}(dBm) = Power(dBm) + ARpl(dBm)$

. Over Limit = $P_{Mea}(dBm) - Limit(dBm)$

. Both QPSK and 16QAM modes have been evaluated, with the worst mode being QPSK.

10. FREQUENCY STABILITY

RULE PART(S)

FCC: §2.1055, §22.355, §24.235, §27.54

LIMITS

§22.355 - The carrier frequency shall not depart from the reference frequency in excess of ± 2.5 ppm for mobile stations.

§24.235 - The frequency stability shall be sufficient to ensure that the fundamental emission stays within the authorized frequency block.

TEST PROCEDURE

Use CMW 500 with Frequency Error measurement capability.

Temp. = -30° to $+50^{\circ}$ C

Voltage = low voltage, DC 3.4V, Normal, DC 3.85V and High voltage, DC 4.4V.

Frequency Stability vs Temperature:

The EUT is placed inside a temperature chamber. The temperature is set to -30° C and allowed to stabilize. After sufficient soak time, the transmitting frequency error is measured. The temperature is increased by 10 degrees, allowed to stabilize and soak, and then the measurement is repeated. This is repeated until $+50^{\circ}$ C is reached.

Frequency Stability vs Voltage:

The peak frequency error is recorded (worst-case).

MODES TESTED

LTE Band 2

LTE Band 4

LTE Band 5

LTE Band 7

LTE Band 12

LTE Band 17

RESULTS

See the following pages.

10.1 LTE BAND 2

QPSK, (20MHz BANDWIDTH)

Frequency error vs. Voltage

Voltage [Vdc]	Frequency [MHz]	Frequency* Error[Hz]	Frequency Error[ppm]	Limit [ppm]
BAND 2 QPSK, (CH 18900 RB size 100 RB Offset 0 20MHz BANDWIDTH)				
3.4	1880	-12.91	-0.006867	2.5
3.85	1880	-10.34	-0.005500	2.5
4.4	1880	-8.30	-0.004415	2.5

Frequency error vs. Temperature

Temperature [° C]	Frequency [MHz]	Frequency* Error[Hz]	Frequency Error[ppm]	Limit [ppm]
BAND 2 QPSK, (CH 18900 RB size 100 RB Offset 0 20MHz BANDWIDTH)				
Normal (25C)	1880	-19.73	-0.010495	2.5
Extreme (50C)	1880	-17.61	-0.009367	2.5
Extreme (40C)	1880	-17.74	-0.009436	2.5
Extreme (30C)	1880	-18.72	-0.009957	2.5
Extreme (10C)	1880	-7.33	-0.003899	2.5
Extreme (0C)	1880	-9.24	-0.004915	2.5
Extreme (-10C)	1880	-16.91	-0.008995	2.5
Extreme (-20C)	1880	-17.13	-0.009112	2.5
Extreme (-30C)	1880	-16.82	-0.008947	2.5

16QAM, (20MHz BANDWIDTH)

Frequency error vs. Voltage

Voltage [Vdc]	Frequency [MHz]	Frequency* Error[Hz]	Frequency Error[ppm]	Limit [ppm]
BAND 2 16QAM, (CH 18900 RB size 100 RB Offset 0 20MHz BANDWIDTH)				
3.4	1880	-8.48	-0.004511	2.5
3.85	1880	-12.13	-0.006452	2.5
4.4	1880	-9.94	-0.005287	2.5

Frequency error vs. Temperature

Temperature [° C]	Frequency [MHz]	Frequency* Error[Hz]	Frequency Error[ppm]	Limit [ppm]
BAND 2 16QAM, (CH 18900 RB size 100 RB Offset 0 20MHz BANDWIDTH)				
Normal (25C)	1880	-13.91	-0.007399	2.5
Extreme (50C)	1880	-11.13	-0.005920	2.5
Extreme (40C)	1880	-10.73	-0.005707	2.5
Extreme (30C)	1880	-12.94	-0.006883	2.5
Extreme (10C)	1880	-13.81	-0.007346	2.5
Extreme (0C)	1880	-10.72	-0.005702	2.5
Extreme (-10C)	1880	-12.12	-0.006447	2.5
Extreme (-20C)	1880	-11.94	-0.006351	2.5
Extreme (-30C)	1880	-13.27	-0.007059	2.5

*Note: Frequency error measurements were made by using the build-in capability of the Wireless Communication Test Set.

10.2 LTE BAND 4

QPSK, (10MHz BANDWIDTH)

Frequency error vs. Voltage

Voltage [Vdc]	Frequency [MHz]	Frequency* Error[Hz]	Frequency Error[ppm]	Limit [ppm]
BAND 4 QPSK, (CH 20175 RB size 100 RB Offset 0 20MHz BANDWIDTH)				
3.4	1732.5	-6.92	-0.003994	2.5
3.85	1732.5	-8.34	-0.004814	2.5
4.4	1732.5	-10.41	-0.006009	2.5

Frequency error vs. Temperature

Temperature [°C]	Frequency [MHz]	Frequency* Error[Hz]	Frequency Error[ppm]	Limit [ppm]
BAND 4 QPSK, (CH 20175 RB size 100 RB Offset 0 20MHz BANDWIDTH)				
Normal (25C)	1732.5	-9.41	-0.005431	2.5
Extreme (50C)	1732.5	-10.17	-0.005870	2.5
Extreme (40C)	1732.5	-9.84	-0.005680	2.5
Extreme (30C)	1732.5	-8.88	-0.005126	2.5
Extreme (10C)	1732.5	-10.13	-0.005847	2.5
Extreme (0C)	1732.5	-10.39	-0.005997	2.5
Extreme (-10C)	1732.5	-10.64	-0.006141	2.5
Extreme (-20C)	1732.5	-9.87	-0.005697	2.5
Extreme (-30C)	1732.5	-10.26	-0.005922	2.5

16QAM, (20MHz BANDWIDTH)

Frequency error vs. Voltage

Voltage [Vdc]	Frequency [MHz]	Frequency* Error[Hz]	Frequency Error[ppm]	Limit [ppm]
BAND 4 16QAM, (CH 20175 RB size 100 RB Offset 0 20MHz BANDWIDTH)				
3.4	1732.5	-2.98	-0.001720	2.5
3.85	1732.5	-1.93	-0.001114	2.5
4.4	1732.5	-3.74	-0.002159	2.5

Frequency error vs. Temperature

Temperature [°C]	Frequency [MHz]	Frequency* Error[Hz]	Frequency Error[ppm]	Limit [ppm]
BAND 4 16QAM, (CH 20175 RB size 100 RB Offset 0 20MHz BANDWIDTH)				
Normal (25C)	1732.5	-2.18	-0.001261	2.5
Extreme (50C)	1732.5	-3.57	-0.002060	2.5
Extreme (40C)	1732.5	-4.07	-0.002349	2.5
Extreme (30C)	1732.5	-2.95	-0.001701	2.5
Extreme (10C)	1732.5	-3.19	-0.001840	2.5
Extreme (0C)	1732.5	-4.93	-0.002844	2.5
Extreme (-10C)	1732.5	-3.05	-0.001759	2.5
Extreme (-20C)	1732.5	-2.54	-0.001466	2.5
Extreme (-30C)	1732.5	-4.99	-0.002879	2.5

***Note:** Frequency error measurements were made by using the build-in capability of the Wireless Communication Test Set.

10.3 LTE BAND 5

QPSK, (10MHz BANDWIDTH)

Frequency error vs. Voltage

Voltage [Vdc]	Frequency [MHz]	Frequency* Error[Hz]	Frequency Error[ppm]	Limit [ppm]
BAND 5 QPSK, (CH 20525 RB size 50 RB Offset 0 10MHz BANDWIDTH)				
3.4	836.5	-9.84	-0.011763	2.5
3.85	836.5	-10.07	-0.012035	2.5
4.4	836.5	-7.98	-0.009541	2.5

Frequency error vs. Temperature

Temperature [° C]	Frequency [MHz]	Frequency* Error[Hz]	Frequency Error[ppm]	Limit [ppm]
BAND 5 QPSK, (CH 20525 RB size 50 RB Offset 0 10MHz BANDWIDTH)				
Normal (25C)	836.5	-9.59	-0.011467	2.5
Extreme (50C)	836.5	-7.29	-0.008719	2.5
Extreme (40C)	836.5	-7.15	-0.008547	2.5
Extreme (30C)	836.5	-9.55	-0.011415	2.5
Extreme (10C)	836.5	-8.78	-0.010497	2.5
Extreme (0C)	836.5	-9.51	-0.011368	2.5
Extreme (-10C)	836.5	-10.24	-0.012236	2.5
Extreme (-20C)	836.5	-7.41	-0.008860	2.5
Extreme (-30C)	836.5	-7.35	-0.008783	2.5

16QAM, (10MHz BANDWIDTH)

Frequency error vs. Voltage

Voltage [Vdc]	Frequency [MHz]	Frequency* Error[Hz]	Frequency Error[ppm]	Limit [ppm]
BAND 5 16QAM, (CH 20525 RB size 50 RB Offset 0 10MHz BANDWIDTH)				
3.4	836.5	-7.72	-0.009229	2.5
3.85	836.5	-6.5	-0.007770	2.5
4.4	836.5	-6.9	-0.008249	2.5

Frequency error vs. Temperature

Temperature [° C]	Frequency [MHz]	Frequency* Error[Hz]	Frequency Error[ppm]	Limit [ppm]
BAND 5 16QAM, (CH 20525 RB size 50 RB Offset 0 10MHz BANDWIDTH)				
Normal (25C)	836.5	-6.03	-0.007203	2.5
Extreme (50C)	836.5	-9.59	-0.011467	2.5
Extreme (40C)	836.5	-8.47	-0.010123	2.5
Extreme (30C)	836.5	-5.35	-0.006400	2.5
Extreme (10C)	836.5	-5.64	-0.006744	2.5
Extreme (0C)	836.5	-9.82	-0.011735	2.5
Extreme (-10C)	836.5	-9.85	-0.011776	2.5
Extreme (-20C)	836.5	-9.70	-0.011598	2.5
Extreme (-30C)	836.5	-8.93	-0.010675	2.5

***Note:** Frequency error measurements were made by using the build-in capability of the Wireless Communication Test Set.

10.4 LTE BAND 7

QPSK, (20MHz BANDWIDTH)

Frequency error vs. Voltage

Voltage [Vdc]	Frequency [MHz]	Frequency* Error[Hz]	Frequency Error[ppm]	Limit [ppm]
BAND 7 QPSK, (CH 21100 RB size 100 RB Offset 0 20MHz BANDWIDTH)				
3.4	2535	-1.71	-0.000674	2.5
3.85	2535	-3.49	-0.001378	2.5
4.4	2535	-3.07	-0.001211	2.5

Frequency error vs. Temperature

Temperature [° C]	Frequency [MHz]	Frequency* Error[Hz]	Frequency Error[ppm]	Limit [ppm]
BAND 7 QPSK, (CH 21100 RB size 100 RB Offset 0 20MHz BANDWIDTH)				
Normal (25C)	2535	-2.03	-0.000799	2.5
Extreme (50C)	2535	-2.21	-0.000872	2.5
Extreme (40C)	2535	-3.46	-0.001364	2.5
Extreme (30C)	2535	-2.59	-0.001021	2.5
Extreme (10C)	2535	-2.67	-0.001054	2.5
Extreme (0C)	2535	-2.77	-0.001093	2.5
Extreme (-10C)	2535	-2.72	-0.001072	2.5
Extreme (-20C)	2535	-2.04	-0.000803	2.5
Extreme (-30C)	2535	-3.67	-0.001446	2.5

16QAM, (20MHz BANDWIDTH)

Frequency error vs. Voltage

Voltage [Vdc]	Frequency [MHz]	Frequency* Error[Hz]	Frequency Error[ppm]	Limit [ppm]
BAND 7 16QAM, (CH 21100 RB size 100 RB Offset 0 20MHz BANDWIDTH)				
3.4	2535	-4.78	-0.001886	2.5
3.85	2535	-5.34	-0.002108	2.5
4.4	2535	-3.01	-0.001186	2.5

Frequency error vs. Temperature

Temperature [° C]	Frequency [MHz]	Frequency* Error[Hz]	Frequency Error[ppm]	Limit [ppm]
BAND 7 16QAM, (CH 21100 RB size 100 RB Offset 0 20MHz BANDWIDTH)				
Normal (25C)	2535	-7.40	-0.002917	2.5
Extreme (50C)	2535	-3.16	-0.001245	2.5
Extreme (40C)	2535	-5.80	-0.002288	2.5
Extreme (30C)	2535	-4.42	-0.001744	2.5
Extreme (10C)	2535	-5.98	-0.002359	2.5
Extreme (0C)	2535	-4.96	-0.001956	2.5
Extreme (-10C)	2535	-4.57	-0.001804	2.5
Extreme (-20C)	2535	-7.99	-0.003151	2.5
Extreme (-30C)	2535	-6.23	-0.002459	2.5

***Note:** Frequency error measurements were made by using the build-in capability of the Wireless Communication Test Set.

10.5 LTE BAND 12

QPSK, (10MHz BANDWIDTH)

Frequency error vs. Voltage

Voltage [Vdc]	Frequency [MHz]	Frequency* Error[Hz]	Frequency Error[ppm]	Limit [ppm]
BAND 12 QPSK, (CH 23095 RB size 50 RB Offset 0 10MHz BANDWIDTH)				
3.4	707.5	-4.93	-0.006968	2.5
3.85	707.5	-3.34	-0.004717	2.5
4.4	707.5	-3.40	-0.004806	2.5

Frequency error vs. Temperature

Temperature [° C]	Frequency [MHz]	Frequency* Error[Hz]	Frequency Error[ppm]	Limit [ppm]
BAND 12 QPSK, (CH 23095 RB size 50 RB Offset 0 10MHz BANDWIDTH)				
Normal (25C)	707.5	-7.33	-0.010361	2.5
Extreme (50C)	707.5	-6.37	-0.009007	2.5
Extreme (40C)	707.5	-5.27	-0.007455	2.5
Extreme (30C)	707.5	-7.61	-0.010757	2.5
Extreme (10C)	707.5	-7.54	-0.010661	2.5
Extreme (0C)	707.5	-5.77	-0.008162	2.5
Extreme (-10C)	707.5	-7.36	-0.010401	2.5
Extreme (-20C)	707.5	-5.12	-0.007234	2.5
Extreme (-30C)	707.5	-7.18	-0.010152	2.5

16QAM, (10MHz BANDWIDTH)

Frequency error vs. Voltage

Voltage [Vdc]	Frequency [MHz]	Frequency* Error[Hz]	Frequency Error[ppm]	Limit [ppm]
BAND 12 16QAM, (CH 23095 RB size 50 RB Offset 0 10MHz BANDWIDTH)				
3.4	707.5	-11.89	-0.016810	2.5
3.85	707.5	-8.22	-0.011620	2.5
4.4	707.5	-8.80	-0.012442	2.5

Frequency error vs. Temperature

Temperature [° C]	Frequency [MHz]	Frequency* Error[Hz]	Frequency Error[ppm]	Limit [ppm]
BAND 12 QPSK, (CH 23095 RB size 50 RB Offset 0 10MHz BANDWIDTH)				
Normal (25C)	707.5	-10.84	-0.015322	2.5
Extreme (50C)	707.5	-8.69	-0.012279	2.5
Extreme (40C)	707.5	-12.85	-0.018157	2.5
Extreme (30C)	707.5	-11.85	-0.016745	2.5
Extreme (10C)	707.5	-11.74	-0.016596	2.5
Extreme (0C)	707.5	-8.23	-0.011632	2.5
Extreme (-10C)	707.5	-12.52	-0.017702	2.5
Extreme (-20C)	707.5	-12.45	-0.017593	2.5
Extreme (-30C)	707.5	-11.17	-0.015786	2.5

***Note:** Frequency error measurements were made by using the build-in capability of the Wireless Communication Test Set.

10.6 LTE BAND 17

QPSK, (10MHz BANDWIDTH)

Frequency error vs. Voltage

Voltage [Vdc]	Frequency [MHz]	Frequency* Error[Hz]	Frequency Error[ppm]	Limit [ppm]
BAND 17 QPSK, (CH 23790 RB size 50 RB Offset 0 10MHz BANDWIDTH)				
3.4	710.0	-3.93	-0.005535	2.5
3.85	710.0	-5.88	-0.008283	2.5
4.4	710.0	-2.79	-0.003928	2.5

Frequency error vs. Temperature

Temperature [° C]	Frequency [MHz]	Frequency* Error[Hz]	Frequency Error[ppm]	Limit [ppm]
BAND 17 QPSK, (CH 23790 RB size 50 RB Offset 0 10MHz BANDWIDTH)				
Normal (25C)	710.0	-4.33	-0.006103	2.5
Extreme (50C)	710.0	-3.08	-0.004345	2.5
Extreme (40C)	710.0	-3.50	-0.004923	2.5
Extreme (30C)	710.0	-5.50	-0.007746	2.5
Extreme (10C)	710.0	-3.25	-0.004579	2.5
Extreme (0C)	710.0	-3.21	-0.004523	2.5
Extreme (-10C)	710.0	-4.21	-0.005932	2.5
Extreme (-20C)	710.0	-5.43	-0.007648	2.5
Extreme (-30C)	710.0	-2.51	-0.003531	2.5

16QAM, (10MHz BANDWIDTH)

Frequency error vs. Voltage

Voltage [Vdc]	Frequency [MHz]	Frequency* Error[Hz]	Frequency Error[ppm]	Limit [ppm]
BAND 17 16QAM, (CH 23790 RB size 50 RB Offset 0 10MHz BANDWIDTH)				
3.4	710.0	-7.59	-0.010690	2.5
3.85	710.0	-7.81	-0.011001	2.5
4.4	710.0	-5.26	-0.007402	2.5

Frequency error vs. Temperature

Temperature [° C]	Frequency [MHz]	Frequency* Error[Hz]	Frequency Error[ppm]	Limit [ppm]
BAND 17 QPSK, (CH 23790 RB size 50 RB Offset 0 10MHz BANDWIDTH)				
Normal (25C)	710.0	-9.66	-0.013605	2.5
Extreme (50C)	710.0	-7.56	-0.010642	2.5
Extreme (40C)	710.0	-8.75	-0.012327	2.5
Extreme (30C)	710.0	-9.19	-0.012944	2.5
Extreme (10C)	710.0	-5.39	-0.007591	2.5
Extreme (0C)	710.0	-9.19	-0.012939	2.5
Extreme (-10C)	710.0	-9.75	-0.013728	2.5
Extreme (-20C)	710.0	-5.51	-0.007755	2.5
Extreme (-30C)	710.0	-5.09	-0.007164	2.5

***Note:** Frequency error measurements were made by using the build-in capability of the Wireless Communication Test Set.

11. Peak-to-Average Ratio

11.1 Description of the PAR Measurement

The peak-to-average ratio (PAR) of the transmission may not exceed 13 dB.

11.2 Measuring Instruments

See list of measuring instruments of this test report.

11.3 Test Procedures

1. The EUT was connected to Spectrum Analyzer and Base Station via power divider.
2. The RF output of EUT was connected to the spectrum analyzer by RF cable and attenuator. The path loss was compensated to the results for each measurement.
3. For GSM/EGPRS operating modes:
 - a. Set the RBW = 1MHz, VBW = 1MHz, Peak detector in spectrum analyzer.
 - b. Set EUT in maximum power output, and triggered the burst signal.
 - c. Measured respectively the Peak level and Mean level, and the deviation was recorded as Peak to Average Ratio.
4. For UMTS operating modes:
 - a. Set the CCDF (Complementary Cumulative Distribution Function) option in spectrum analyzer.
 - b. The highest RF powers were measured and recorded the maximum PAPR level associated with a probability of 0.1 %.

11.4 Test Setup

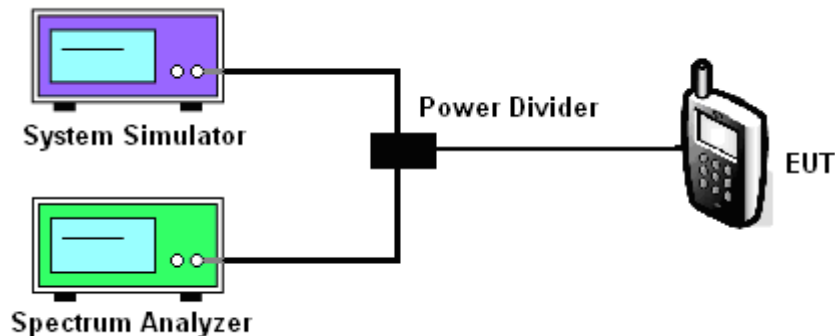

MODES TESTED

- LTE Band 2
- LTE Band 4
- LTE Band 5
- LTE Band 7
- LTE Band 12
- LTE Band 17

Test data reference attachment.

----END OF REPORT----