

# FCC CFR47 PART 27 CERTIFICATION TEST REPORT FCC ID: 2ANMU-WP10

**Product:** Smart Phone

**Trade Mark:** OUKITEL

**Model Number:** WP10

**Family Model:** N/A

**Report No.:** S20121001303008

## Prepared for

SHENZHEN YUNJI INTELLIGENT TECHNOLOGY CO.,LTD  
A-SIDE A2 BUILDING 2/F ENET NEW INDUSTRIAL PARK,  
NO.20 DAFU INDUSTRIAL ZONE, AOBEL COMMUNITY, GUANLAN,  
LONGHUA NEW DISTRICT, SHENZHEN CHINA

## Prepared by

Shenzhen NTEK Testing Technology Co., Ltd.  
1/F, Building E, Fenda Science Park, Sanwei Community, Xixiang Street  
Bao'an District, Shenzhen 518126 P.R. China  
Tel.: 400-800-6106, 0755-3699 5508  
Website: <http://www.ntek.org.cn>

## TEST RESULT CERTIFICATION

**Applicant's name** ..... : SHENZHEN YUNJI INTELLIGENT TECHNOLOGY CO.,LTD  
**Address**..... : A-SIDE A2 BUILDING 2/F ENET NEW INDUSTRIAL PARK,NO.20  
DAFU INDUSTRIAL ZONE, AOBEI COMMUNITY, GUANLAN,  
LONGHUA NEW DISTRICT,SHENZHEN CHINA  
**Manufacturer's Name**..... : SHENZHEN YUNJI INTELLIGENT TECHNOLOGY CO.,LTD  
**Address**..... : A-SIDE A2 BUILDING 2/F ENET NEW INDUSTRIAL PARK,NO.20  
DAFU INDUSTRIAL ZONE, AOBEI COMMUNITY, GUANLAN,  
LONGHUA NEW DISTRICT,SHENZHEN CHINA  
**Product name**..... : Smart Phone  
**Model and/or type reference** .. : WP10  
**Family Model:** N/A  
**Standards**..... : FCC CFR 47 Part 27  
**Test procedure** .....: ANSI C63.46:2015  
ANSI/TIA-603-E-2016

This device described above has been tested by NTEK, and the test results show that the equipment under test (EUT) is in compliance with the FCC requirements. And it is applicable only to the tested sample identified in the report.

This report shall not be reproduced except in full, without the written approval of NTEK, this document may be altered or revised by NTEK, personal only, and shall be noted in the revision of the document.

**Date of Test** .....

Date (s) of performance of tests..... 10 Dec. 2020 ~31 Dec, 2020

Date of Issue ..... 31 Dec, 2020

Test Result..... **Pass**

Testing Engineer : Cheng Jiawen  
(Cheng Jiawen)

Technical Manager : Jason Chen  
(Jason Chen)

Authorized Signatory : Alex  
(Alex Li)

## TABLE OF CONTENTS

<b>1. GENERAL INFORMATION.....</b>	<b>6</b>
<b>1.1 PRODUCT DESCRIPTION .....</b>	<b>6</b>
<b>1.2 RELATED SUBMITTAL(S) / GRANT (S) .....</b>	<b>7</b>
<b>1.3 TEST METHODOLOGY.....</b>	<b>7</b>
<b>1.4 TEST FACILITY.....</b>	<b>7</b>
<b>MEASUREMENT UNCERTAINTY .....</b>	<b>7</b>
<b>1.5 SPECIAL ACCESSORIES.....</b>	<b>7</b>
<b>1.6 WORST-CASE CONFIGURATION AND MODE.....</b>	<b>7</b>
<b>1.6 SUMMARY OF TEST RESULTS .....</b>	<b>8</b>
<b>2. SYSTEM TEST CONFIGURATION .....</b>	<b>9</b>
<b>2.1 EUT CONFIGURATION.....</b>	<b>9</b>
<b>2.2 EUT EXERCISE .....</b>	<b>9</b>
<b>2.3 CONFIGURATION OF EUT SYSTEM.....</b>	<b>9</b>
<b>2.4 TEST SETUP .....</b>	<b>10</b>
<b>3.TEST AND MEASUREMENT EQUIPMENT .....</b>	<b>11</b>
<b>4. OUTPUT POWER.....</b>	<b>13</b>
<b>4.1 OUTPUT POWER MEASUREMENT .....</b>	<b>13</b>
<b>5. OCCUPIED BANDWIDTH .....</b>	<b>14</b>
<b>6. BANEDGE AND EMISSION MASK.....</b>	<b>15</b>
<b>7. OUT OF BAND EMISSIONS .....</b>	<b>16</b>
<b>8. RADIATED MEASUREMENT .....</b>	<b>18</b>
<b>8.1. RADIATED POWER (ERP &amp; EIRP).....</b>	<b>18</b>
<b>8.2 NR BAND 5 .....</b>	<b>19</b>
<b>8.5 NR BAND 41.....</b>	<b>21</b>
<b>9. SPURIOUS RADIATION EMISSION .....</b>	<b>25</b>

9.3 NR BAND 5.....	27
9.4 NR BAND 41.....	31
10. FREQUENCY STABILITY .....	35
10.3 NR BAND 5.....	36
10.4 NR BAND 41.....	38
11. PEAK-TO-AVERAGE RATIO.....	40
11.1 Description of the PAR Measurement.....	40
11.2 Measuring Instruments .....	40
11.3 Test Procedures.....	40
11.4 Test Setup.....	40

# 1. GENERAL INFORMATION

## 1.1 PRODUCT DESCRIPTION

A major technical description of EUT is described as following:

Product Designation:	Smart Phone
Trade Mark	OUKITEL
Model Name	WP10
Family Model	N/A
Model Difference	N/A
FCC ID:	2ANMU-WP10
Frequency Bands:	U.S. Bands: <input checked="" type="checkbox"/> NR FDD Band 5, NR TDD Band 41
Frequency Range:	NR FDD Band 5 Uplink: 824MHz-849MHz, Downlink: 869MHz-894MHz; NR TDD Band 41 Uplink/Downlink: 2496 MHz - 2690 MHz
Type of Modulation:	DFT-s-OFDM:PI/2 BPSK/QPSK/16-QAM/64QAM/256QAM CP-OFDM: QPSK/16-QAM/64QAM/256QAM
Subcarrier spacing	<input checked="" type="checkbox"/> 15KHz, <input checked="" type="checkbox"/> 30KHz, <input type="checkbox"/> 60KHz
NR architecture	<input checked="" type="checkbox"/> SA, <input type="checkbox"/> NSA
Antenna:	FPC Antenna
Antenna gain:	Band 5: -0.9dBi, Band 41: 0.6dBi,
Power Supply:	DC 3.85V/8000mAh from battery or DC 9V from Adapter.
Adapter:	Model: HJ-FC017K7-US Input: 100-240V~50/60Hz 0.6A Output: 5V---2000mA 7V---2000mA 9V---2000mA 12V---1500mA 18.0W
Extreme Vol. Limits:	DC 3.4V to DC 4.4V (Nominal DC 3.85V) (Note 1)
HW Version	HCT-S1000MB-A2
SW Version	OUKITEL_WP10_EEA_V01_202001016
** Note1: The High Voltage 4.4V and Low Voltage 3.4V was declared by manufacturer, The EUT couldn't be operate normally with higher or lower voltage.	

## 1.2 RELATED SUBMITTAL(S) / GRANT (S)

This submittal(s) (test report) is intended for **FCC ID: 2ANMU-WP10** filing to comply with the FCC Part 27.

## 1.3 TEST METHODOLOGY

The tests documented in this report were performed in accordance with ANSI/TIA-603-E-2016, FCC CFR 47 Part 2, Part 27, ANSI C63.46:2015.

## 1.4 TEST FACILITY

The test site used to collect the radiated data is located at:

ShenZhen NTEK Testing Technology Co., Ltd.

1/F, Building E, Fenda Science Park, Sanwei Community, Xixiang Street, Bao'an District, Shenzhen 518126 P.R.China.

The test site is constructed and calibrated to meet the FCC requirements in documents ANSI C63.46:2015& ANSI C63.4: 2014.

FCC Registration No.:463705

IC Registration No.:9270A-1,

CNAS Registration No.:L5516

## MEASUREMENT UNCERTAINTY

The reported uncertainty of measurement, where expended uncertainty U is based on a standard uncertainty multiplied by a coverage factor of k=2, providing a level of confidence of approximately 95 %.

No.	Item	Uncertainty
1	Measuring Uncertainty for a Level of Confidence of 95% ( $U = 2U_c(y)$ )	2.5dB

## 1.5 SPECIAL ACCESSORIES

The battery and the charger, earphone supplied by the applicant were used as accessories and being tested with EUT intended for FCC grant together.

## 1.6 WORST-CASE CONFIGURATION AND MODE

The worst-case scenario for all measurements is based on the investigation results.

The device has NR Bands of: Band 5, Band 41.

The RB Size was selected to measure for peak or average ERP and EIRP, which was based on the conducted power verification baseline data.

For the fundamental investigation of radiated emissions, the EUT is investigated for vertical and horizontal antenna orientations and X Y and Z orientations of the EUT alone. After the investigations the worst case was determined to be at X orientation for all LTE bands.

**1.6 SUMMARY OF TEST RESULTS**

<b>FCC Part27, Subpart L, KDB 971168 D01 Power Meas License Digital Systems v03</b>			
<b>FCC Rule</b>	<b>Test Item</b>	<b>Verdict</b>	<b>Remark</b>
2.1046	Conducted Output Power	PASS	
27.50(d)(5) KDB 971168 D01 Clause 5.7	Peak-to-Average Ratio	PASS	
2.1049 KDB 971168 D01 Clause 4.2	Occupied Bandwidth	PASS	
2.1051 27.53(c), (g), (h) KDB 971168 D01 Clause 6	Band Edge	PASS	
27.50(b)(10), (c)(10) KDB 971168 D01 Clause 5.6	Effective Radiated Power	PASS	
27.50(h)(2), (d)(4) KDB 971168 D01 Clause 5.6	Equivalent Isotropic Radiated Power	PASS	
2.1053 27.53(c)(g)(h)(m) KDB 971168 D01 Clause 7	Field Strength of Spurious Radiation	PASS	
2.1055 27.54 KDB 971168 D01 Clause 9	Frequency Stability for Temperature & Voltage	PASS	
2.1051 27.53(c)(g)(h)(m) KDB 971168 D01 Clause 6	Conducted Emission	PASS	
<p>Remark:</p> <ol style="list-style-type: none"> <li>1. "N/A" denotes test is not applicable in this Test Report.</li> <li>2. All test items were verified and recorded according to the standards and without any deviation during the test.</li> <li>3. No modifications are made to the EUT during all test items.</li> </ol>			



## 2. SYSTEM TEST CONFIGURATION

### 2.1 EUT CONFIGURATION

The EUT configuration for testing is installed on RF field strength measurement to meet the Commission's requirement and operating in a manner which intends to maximize its emission characteristics in a continuous normal application.

### 2.2 EUT EXERCISE

The Transmitter was operated in the maximum output power mode through Communication Tester. The TX frequency was fixed which was for the purpose of the measurements.

### 2.3 CONFIGURATION OF EUT SYSTEM

Table 2-1 Equipment Used in EUT System

Item	Equipment	Model No.	ID or Specification	Note
1	Smart Phone	WP10	FCC ID: 2ANMU-WP10	EUT

*Note: All the accessories have been used during the test.  
the following "EUT" in setup diagram means EUT system.*

## 2.4 TEST SETUP

For Radiated Test Cases

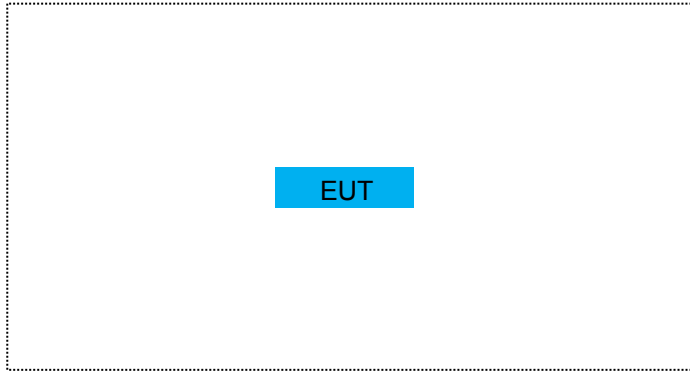

For Conducted Output Power

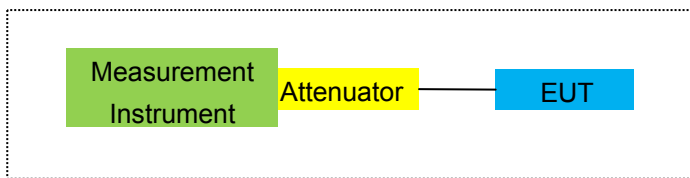

For Peak-to Average Ratio, Occupied Bandwidth, Conducted Band edge and Conducted Spurious Emission

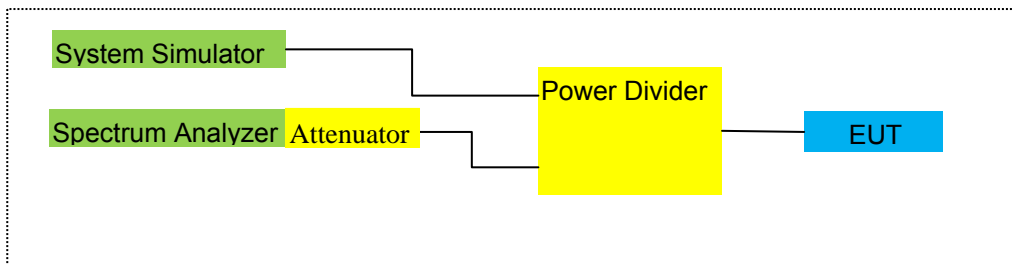

For Frequency Stability

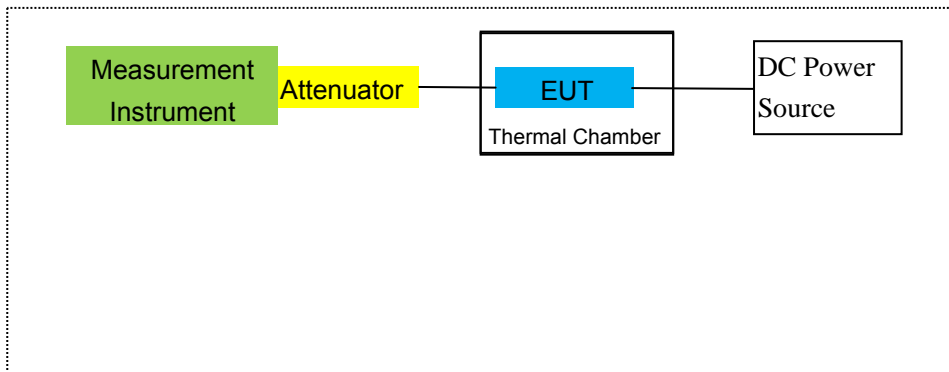

Note: EUT built-in battery-powered, the battery is fully-charged.

### 3.TEST AND MEASUREMENT EQUIPMENT

The following test and measurement equipment was utilized for the tests documented in this report:

Item	Kind of Equipment	Manufacturer	Type No.	Serial No.	Last calibration	Calibrated until	Calibration period
1	MXA Signal Analyzer	Agilent	N9020A	MY49100060	2020.07.13	2021.07.12	1 year
2	Test Receiver	R&S	ESPI	101318	2020.05.11	2021.05.10	1 year
3	Bilog Antenna	TESEQ	CBL6111D	31216	2020.04.11	2021.04.10	1 year
4	50Ω Coaxial Switch	Anritsu	MP59B	6200983705	2020.05.11	2023.05.10	3 year
5	Horn Antenna	EM	EM-AH-10180	2011071402	2020.04.11	2021.04.10	1 year
6	Horn Ant	Schwarzbeck	BBHA 9170	9170-181	2020.07.13	2021.07.12	1 year
7	Amplifier	EM	EM-30180	060538	2020.07.13	2021.07.12	1 year
8	Loop Antenna	ARA	PLA-1030/B	1029	2020.05.11	2021.05.10	1 year
9	Power Meter	R&S	NRVS	100696	2020.07.13	2021.07.12	1 year
10	Power Sensor	R&S	URV5-Z4	0395.1619.05	2020.05.11	2021.05.10	1 year
11	Test Cable	N/A	R-01	N/A	2019.08.06	2022.08.05	3 year
12	Test Cable	N/A	R-02	N/A	2020.07.13	2021.07.12	1 year
13	Test Cable	N/A	R-03	N/A	2019.06.28	2022.06.27	3 year
14	Test Receiver	R&S	ESCI	101160	2020.05.11	2021.05.10	1 year
15	LISN	R&S	ENV216	101313	2020.05.11	2021.05.10	1 year
16	LISN	EMCO	3816/2	00042990	2020.05.11	2021.05.10	1 year
17	50Ω Coaxial Switch	Anritsu	MP59B	6200264417	2020.05.11	2021.05.10	1 year
18	Passive Voltage Probe	R&S	ESH2-Z3	100196	2020.04.11	2021.04.10	1 year
19	Test Cable	N/A	C01	N/A	2020.05.11	2023.05.10	3 year
20	Test Cable	N/A	C02	N/A	2020.05.11	2023.05.10	3 year
21	Test Cable	N/A	C03	N/A	2020.05.11	2021.05.10	1 year
22	Attenuator	MCE	24-10-34	BN9258	2020.05.11	2021.05.10	1 year
23	Spectrum Analyzer	agilent	e4440a	us44300399	2020.05.11	2021.05.10	1 year
24	test receiver	R&S	ESCI	a0304218	2020.05.11	2021.05.10	1 year
25	Communication Tester	R&S	CMU200	A0304247	2020.07.13	2021.07.12	1 year
26	Thermal Chamber	Ten Billion	TTC-B3C	TBN-960502	2020.05.11	2021.05.10	1 year

27	DC Power Source	N/A	PS-6005D	2017040292 3	2020.07.13	2021.07.12	1 year
28	PSG Analog Signal Generator	Agilent	E8257D	MY51110112	2020.07.13	2021.07.12	1 year
29	Communication Tester	R&S	CMW500	148500	2020.05.11	2021.05.10	1 year
30	Radio Communication Analyzer	Anritsu	MT8821C	SN 6262186364	2020.10.13	2021.10.12	1 year
31	Radio Communication Test Station	Anritsu	MT8000A	SN 6262192315	2020.10.13	2021.10.12	1 year

Note: Each piece of equipment is scheduled for calibration once a year except the Test Cable& DC Power Source which is scheduled for calibration every 3 years.

## 4. OUTPUT POWER

### 4.1 OUTPUT POWER MEASUREMENT

#### NR Measurement Procedure:

All NR bands conducted power peak and average are obtained from the MT8821C telecommunication test set. The following tests were conducted according to the test requirements outlined in section 6.2 of the 3GPP TS 38.521-1 specification.

UE Power Class: 3 (23 +/- 2dBm). The allowed Maximum Power Reduction (MPR) for the maximum output power due to higher order modulation and transmit bandwidth configuration (resource blocks) is specified in Table Table 6.2.2.3-1: of the 3GPP TS 38.521-1 (V15.3.0) (07-2019).

**Table 6.2.2.3-1: UE Power Class**

EUTRA band	Class 1 (dBm)	Tolerance (dB)	Class 2 (dBm)	Tolerance (dB)	Class 3 (dBm)	Tolerance (dB)	Class 4 (dBm)	Tolerance (dB)
1					23	±2		
2					23	±2 <sup>2</sup>		
3					23	±2 <sup>2</sup>		
4					23	±2		
5					23	±2		
~					~	~		
40					23	±2		
41					23	±2 <sup>2</sup>		
42					23	+2/-3		
43					23	+2/-3		
44					23	+2/[-3]		
45					23	±2		
47			26	±2	23	±2		

The allowed A-MPR values specified below in Table 6.2.4.-1 of 3GPP TS 38.521-1 are in addition to the allowed MPR requirements. All the measurements below were performed with A-MPR disabled, by using Network Signaling Value of "NS\_01".<sup>3</sup>

Test data reference attachment.

## **5. OCCUPIED BANDWIDTH**

### **RULE PART(S)**

FCC: §2.1049

### **LIMITS**

For reporting purposes only

### **TEST PROCEDURE**

The transmitter output was connected to a calibrated coaxial cable and coupler, the other end of which was connected to a spectrum analyzer. The occupied bandwidth was measured with the spectrum analyzer at the low, middle and high channel in each band. The -26dB bandwidth was also measured and recorded.

### **MODES TESTED**

NR Band 5

NR Band 41

### **RESULTS**

**PASS**

Test data reference attachment.

## 6. BANDEDGE AND EMISSION MASK

### RULE PART(S)

FCC: §2.1051, §27.53(c)(g)(h)(m)

FCC: §2.1046,

### LIMITS

The minimum permissible attenuation level of any spurious emission is  $43 + \log_{10}(P[\text{Watts}])$ , where P is the transmitter power in Watts.

The minimum permissible attenuation level for Band 7 is as following.

Per 27.53(g) for operations in the 698-746 MHz band, in the 100 kHz bands immediately outside and adjacent to the frequency block a resolution bandwidth of at least 30 kHz may be employed to demonstrate compliance with the out-of-band emissions limit.

Per 27.53(c.5) for operations in the 776-788 MHz band, in the 100 kHz bands immediately outside and adjacent to the frequency block a resolution bandwidth of at least 30 kHz may be employed to demonstrate compliance with the out-of-band emissions limit.

For all plots showing emissions in the 763 – 775MHz and 793 – 805MHz band, the FCC limit per 27.53(c.4) is  $65 + 10\log_{10}(P) = -35\text{dBm}$  in a 6.25kHz bandwidth.

Per 27.53(m) for operations in the BRS/EBS bands, the attenuation factor shall be not less than  $40 + 10 \log (P)$  dB on all frequencies between the channel edge and 5 megahertz from the channel edge,  $43 + 10 \log (P)$  dB on all frequencies between 5 megahertz and X megahertz from the channel edge, and  $55 + 10 \log (P)$  dB on all frequencies more than X megahertz from the channel edge, where X is the greater of 6 megahertz or the actual emission bandwidth.

### TEST PROCEDURE

The transmitter output was connected to a CMW500Test Set and configured to operate at maximum power. The band edge emissions were measured at the required operating frequencies in each band on the Spectrum Analyzer.

For each band edge measurement:

Set the spectrum analyzer span to include the block edge frequency

Set a marker to point the corresponding band edge frequency in each test case.

Set display line

Set resolution bandwidth to at least 1% of emission bandwidth.

### MODES TESTED

NR Band 5

NR Band 41

### RESULTS

Test data reference attachment.

Note: Both DFT-s-OFDM:PI/2 BPSK/QPSK/16-QAM/64QAM/256QAM

CP-OFDM: QPSK/16-QAM/64QAM/256QAM has been tested, the worst case is CP\_QPSK mode, the report just reported the worst case.

## 7. OUT OF BAND EMISSIONS

### RULE PART(S)

FCC: §2.1051, §27.53(c)(g)(h)(m)

### LIMITS

The minimum permissible attenuation level of any spurious emission is  $43 + \log_{10}(P[\text{Watts}])$ , where P is the transmitter power in Watts.

The minimum permissible attenuation level for Band 7 is as following.

Per 27.53(g) for operations in the 698-746 MHz band, in the 100 kHz bands immediately outside and adjacent to the frequency block a resolution bandwidth of at least 30 kHz may be employed to demonstrate compliance with the out-of-band emissions limit.

Per 27.53(c.5) for operations in the 776-788 MHz band, in the 100 kHz bands immediately outside and adjacent to the frequency block a resolution bandwidth of at least 30 kHz may be employed to demonstrate compliance with the out-of-band emissions limit.

For all plots showing emissions in the 763 – 775MHz and 793 – 805MHz band, the FCC limit per 27.53(c.4) is  $65 + 10\log_{10}(P) = -35\text{dBm}$  in a 6.25kHz bandwidth.

Per 27.53(m) for operations in the BRS/EBS bands, the attenuation factor shall be not less than  $40 + 10 \log (P)$  dB on all frequencies between the channel edge and 5 megahertz from the channel edge,  $43 + 10 \log (P)$  dB on all frequencies between 5 megahertz and X megahertz from the channel edge, and  $55 + 10 \log (P)$  dB on all frequencies more than X megahertz from the channel edge, where X is the greater of 6 megahertz or the actual emission bandwidth.

### TEST PROCEDURE

The RF output of the transmitter was connected to a spectrum analyzer through a calibrated coaxial cable. Sufficient scans were taken to show the out-of-band Emissions, if any, up to 10th harmonic. Multiple sweeps were recorded in maximum hold mode using a peak detector to ensure that the worst-case emissions were caught.

For each out of band emissions measurement:

Set display line

Set RBW & VBW to 100 kHz for the measurement below 1 GHz, and 1 MHz for the measurement above 1 GHz.

### MODES TESTED

NR Band 5

NR Band 41



## 7.1 MEASUREMENT METHOD

The test set up and general procedure is similar to conducted peak output power test. Only different for setting the measurement configuration of the measuring instrument of Spectrum Analyzer.

Test data reference attachment.

Note: Both DFT-s-OFDM:PI/2 BPSK/QPSK/16-QAM/64QAM/256QAM

CP-OFDM: QPSK/16-QAM/64QAM/256QAM has been tested, the worst case is CP\_QPSK mode, the report just reported the worst case.

## 8. RADIATED MEASUREMENT

### 8.1. RADIATED POWER (ERP & EIRP)

#### RULE PART(S)

FCC: §2.1046, §27.50 (h)(2), (b)(10), (c)(10), (d)(4)

#### LIMITS:

27.50 (c) (10) the following power and antenna height requirements apply to stations transmitting in the 698–746 MHz band, the portable stations (hand-held devices) are limited to 3 watts ERP.

27.50 (b)(10) Portable stations (hand-held devices) transmitting in the 746–757 MHz, 758–763 MHz, 776–793 MHz, and 805–806 MHz bands are limited to 3 watts ERP.

27.50 (d)(4) The following power and antenna height requirements apply to stations transmitting in the 1710–1755 MHz and 2110–2155 MHz bands: Fixed, mobile, and portable (hand-held) stations operating in the 1710–1755 MHz band are limited to 1 watt EIRP.

27.50 (h)(2) Mobile and other user stations in the 2500–2570 MHz and 2620–2690 MHz bands. Mobile stations are limited to 2.0 watts EIRP. All user stations are limited to 2.0 watts transmitter output power.

#### TEST PROCEDURE

ANSI/TIA-603-E Clause 2.2.17

KDB 971168 v02r01 RF power output using broadband peak and average power meter method.

KDB 971168 D01 Power Meas License Digital Systems v02r01, “Measurement Guidance for Certification of Licensed Digital Transmitters”

#### MODES TESTED

NR Band 5

NR Band 41

#### RESULTS

Pass

## 8.2 NR BAND 5

Radiated Power (ERP) for Band 5 /SCS (30kHz)										
Mode	RB/ RB Position	Frequency	Result							Conclusion
			SG Level (dBm)	Cable Loss (dBm)	Factor Gain (dB)	Correction (dB)	Max. EIRP Average (dBm)	Max. EIRP Average (mW)	Polarization Of Max. ERP	
10MHz DFT_QPSK	1@1	829	6.33	2.01	19.68	2.15	21.85	153.109	Horizontal	Pass
		836.5	6.25	2.01	19.77	2.15	21.86	153.462	Horizontal	Pass
		844	6.18	2.02	19.82	2.15	21.83	152.405	Horizontal	Pass
10MHz DFT_QAM16	1@1	829	5.64	2.01	19.7	2.15	21.18	131.220	Horizontal	Pass
		836.5	5.43	2.01	19.77	2.15	21.04	127.057	Horizontal	Pass
		844	5.43	2.02	19.81	2.15	21.07	127.938	Horizontal	Pass
15MHz DFT_QPSK	1@1	831.5	6.29	2.01	19.71	2.15	21.84	152.757	Horizontal	Pass
		836.5	6.23	2.01	19.77	2.15	21.84	152.757	Horizontal	Pass
		841.5	6.24	2.02	19.79	2.15	21.86	153.462	Horizontal	Pass
15MHz DFT_QAM16	1@1	831.5	5.60	2.01	19.73	2.15	21.17	130.918	Horizontal	Pass
		836.5	5.53	2.01	19.77	2.15	21.14	130.017	Horizontal	Pass
		841.5	5.42	2.02	19.78	2.15	21.03	126.765	Horizontal	Pass
20MHz DFT_QPSK	1@1	834	6.25	2.01	19.68	2.15	21.77	150.314	Horizontal	Pass
		836.5	6.20	2.01	19.77	2.15	21.81	151.705	Horizontal	Pass
		839	6.22	2.02	19.82	2.15	<b>21.87</b>	153.815	Horizontal	Pass
20MHz DFT_QAM16	1@1	834	5.57	2.01	19.7	2.15	21.11	129.122	Horizontal	Pass
		836.5	5.58	2.01	19.77	2.15	21.19	131.522	Horizontal	Pass
		839	5.62	2.02	19.81	2.15	<b>21.26</b>	133.660	Horizontal	Pass

Radiated Power (ERP) for Band 5 SCS (30kHz)										
Mode	RB/ RB Position	Frequency	Result							Conclusion
			SG Level (dBm)	Cable Loss (dBm)	Factor Gain (dB)	Correction (dB)	Max. EIRP Average (dBm)	Max. EIRP Average (mW)	Polarization Of Max. ERP	
10MHz DFT_QPSK	1@1	829	5.05	2.01	19.71	2.15	20.60	114.815	Vertical	Pass
		836.5	5.39	2.01	19.77	2.15	21.00	125.893	Vertical	Pass
		844	5.18	2.02	19.79	2.15	20.80	120.226	Vertical	Pass
10MHz DFT_QAM16	1@1	829	4.83	2.01	19.73	2.15	20.40	109.648	Vertical	Pass
		836.5	4.89	2.01	19.77	2.15	20.50	112.202	Vertical	Pass
		844	5.29	2.02	19.78	2.15	20.90	123.027	Vertical	Pass
15MHz DFT_QPSK	1@1	831.5	6.13	2.01	19.73	2.15	21.70	147.911	Vertical	Pass
		836.5	4.59	2.01	19.77	2.15	20.20	104.713	Vertical	Pass
		841.5	6.29	2.02	19.78	2.15	21.90	154.882	Vertical	Pass
15MHz DFT_QAM16	1@1	831.5	4.63	2.01	19.73	2.15	20.20	104.713	Vertical	Pass
		836.5	5.39	2.01	19.77	2.15	21.00	125.893	Vertical	Pass
		841.5	4.79	2.02	19.78	2.15	20.40	109.648	Vertical	Pass
20MHz DFT_QPSK	1@1	834	6.03	2.01	19.73	2.15	<b>21.60</b>	144.544	Vertical	Pass
		836.5	5.49	2.01	19.77	2.15	21.10	128.825	Vertical	Pass
		839	5.69	2.02	19.78	2.15	21.30	134.896	Vertical	Pass
20MHz DFT_QAM16	1@1	834	5.33	2.01	19.73	2.15	20.90	123.027	Vertical	Pass
		836.5	5.19	2.01	19.77	2.15	20.80	120.226	Vertical	Pass
		839	4.89	2.02	19.78	2.15	20.50	112.202	Vertical	Pass

Note:

ERP=EIRP-2.15

SG Level= Signal generator output

Max. EIRP Average (dBm)= Factor Gain (dB)+ SG Level (dBm)- Cable Loss(dBm)

Factor Gain(dB)=Antenna Gain(dB) + Amplifier Factor (dB)

8.5 NR BAND 41

Radiated Power (EIRP) for Band 41 /SCS (30kHz)									
Mode	RB/ RB Position	Frequency	Result						Conclusion
			SG Level (dBm)	Cable Loss (dBm)	Factor Gain (dB)	Max. EIRP Average (dBm)	Max. EIRP Average (mW)	Polarization Of Max. ERP	
10.0MHz DFT_QPSK	1@1	2501.01	0.75	4.54	27.75	23.96	248.886	Horizontal	Pass
		2592.99	1.94	4.69	27.72	24.97	314.051	Horizontal	Pass
		2685	2.35	4.71	27.71	25.35	342.768	Horizontal	Pass
15.0MHz DFT_QPSK	1@1	2503.5	1.73	4.55	27.76	24.94	311.889	Horizontal	Pass
		2592.99	1.98	4.69	27.72	25.01	316.957	Horizontal	Pass
		2682.48	2.34	4.72	27.7	25.32	340.408	Horizontal	Pass
20.0MHz DFT_QPSK	1@1	2506.02	1.73	4.55	27.77	24.95	312.608	Horizontal	Pass
		2592.99	1.94	4.69	27.72	24.97	314.051	Horizontal	Pass
		2679.99	2.32	4.72	27.69	25.29	338.065	Horizontal	Pass
40.0MHz DFT_QPSK	1@1	2516.01	1.75	4.57	27.78	24.96	313.329	Horizontal	Pass
		2592.99	1.97	4.73	27.72	24.96	313.329	Horizontal	Pass
		2670	2.31	4.75	27.68	25.24	334.195	Horizontal	Pass
50.0MHz DFT_QPSK	1@1	2521.02	1.79	4.54	27.75	25.00	316.228	Horizontal	Pass
		2592.99	1.97	4.69	27.72	25.00	316.228	Horizontal	Pass
		2664.99	2.29	4.71	27.71	25.29	338.065	Horizontal	Pass
60.0MHz DFT_QPSK	1@1	2526	1.79	4.55	27.76	25.00	316.228	Horizontal	Pass
		2592.99	1.95	4.69	27.72	24.98	314.775	Horizontal	Pass
		2659.98	2.30	4.72	27.7	25.28	337.287	Horizontal	Pass
80.0MHz DFT_QPSK	1@1	2536.02	1.81	4.55	27.77	25.03	318.420	Horizontal	Pass
		2592.99	1.96	4.69	27.72	24.99	315.500	Horizontal	Pass
		2649.99	2.29	4.72	27.69	25.26	335.738	Horizontal	Pass
90.0MHz DFT_QPSK	1@1	2541	1.83	4.57	27.78	25.04	319.154	Horizontal	Pass
		2592.99	1.98	4.73	27.72	24.97	314.051	Horizontal	Pass
		2644.98	2.34	4.75	27.68	25.27	336.512	Horizontal	Pass
100.0MHz DFT_QPSK	1@1	2546.01	2.21	4.57	27.78	<b>25.42</b>	348.337	Horizontal	Pass
		2592.99	2.37	4.73	27.72	25.36	343.558	Horizontal	Pass
		2640	2.42	4.75	27.68	25.35	342.768	Horizontal	Pass

Radiated Power (EIRP) for Band 41 /SCS (30kHz)									
Mode	RB/ RB Position	Frequency	Result						Conclusion
			SG Level (dBm)	Cable Loss (dBm)	Factor Gain (dB)	Max. EIRP Average (dBm)	Max. EIRP Average (mW)	Polarization Of Max. ERP	
10.0MHz DFT_QPSK	1@1	2501.01	-0.63	4.54	27.75	22.58	181.134	Vertical	Pass
		2592.99	-0.22	4.69	27.72	22.81	190.985	Vertical	Pass
		2685	-0.96	4.71	27.71	22.04	159.956	Vertical	Pass
15.0MHz DFT_QPSK	1@1	2503.5	-0.61	4.55	27.76	22.6	181.970	Vertical	Pass
		2592.99	-1.01	4.69	27.72	22.02	159.221	Vertical	Pass
		2682.48	-0.88	4.72	27.7	22.1	162.181	Vertical	Pass
20.0MHz DFT_QPSK	1@1	2506.02	-0.44	4.55	27.77	22.78	189.671	Vertical	Pass
		2592.99	-0.83	4.69	27.72	22.2	165.959	Vertical	Pass
		2679.99	-0.87	4.72	27.69	22.1	162.181	Vertical	Pass
40.0MHz DFT_QPSK	1@1	2516.01	-0.83	4.57	27.78	22.38	172.982	Vertical	Pass
		2592.99	-0.93	4.73	27.72	22.06	160.694	Vertical	Pass
		2670	-0.87	4.75	27.68	22.06	160.694	Vertical	Pass
50.0MHz DFT_QPSK	1@1	2521.02	-0.37	4.54	27.75	22.84	192.309	Vertical	Pass
		2592.99	-0.67	4.69	27.72	22.36	172.187	Vertical	Pass
		2664.99	-0.45	4.71	27.71	22.55	179.887	Vertical	Pass
60.0MHz DFT_QPSK	1@1	2526	-0.83	4.55	27.76	22.38	172.982	Vertical	Pass
		2592.99	-0.93	4.69	27.72	22.1	162.181	Vertical	Pass
		2659.98	-0.43	4.72	27.7	22.55	179.887	Vertical	Pass
80.0MHz DFT_QPSK	1@1	2536.02	-1.06	4.55	27.77	22.16	164.437	Vertical	Pass
		2592.99	-0.91	4.69	27.72	22.12	162.930	Vertical	Pass
		2649.99	-0.12	4.72	27.69	22.85	192.752	Vertical	Pass
90.0MHz DFT_QPSK	1@1	2541	-0.64	4.57	27.78	22.57	180.717	Vertical	Pass
		2592.99	-0.49	4.73	27.72	22.5	177.828	Vertical	Pass
		2644.98	-0.11	4.75	27.68	22.82	191.426	Vertical	Pass
100.0MHz DFT_QPSK	1@1	2546.01	-0.86	4.57	27.78	22.35	171.791	Vertical	Pass
		2592.99	-0.81	4.73	27.72	22.18	165.196	Vertical	Pass
		2640	-0.31	4.75	27.68	22.62	182.810	Vertical	Pass

Radiated Power (EIRP) for Band 41 /SCS (30kHz)									
Mode	RB/ RB Position	Frequency	Result						Conclusion
			SG Level (dBm)	Cable Loss (dBm)	Factor Gain (dB)	Max. EIRP Average (dBm)	Max. EIRP Average (mW)	Polarization Of Max. ERP	
10.0MHz DFT_QAM16	1@1	2501.01	0.64	4.54	27.75	23.85	242.661	Horizontal	Pass
		2592.99	0.75	4.69	27.72	23.78	238.781	Horizontal	Pass
		2685	1.14	4.71	27.71	24.14	259.418	Horizontal	Pass
15.0MHz DFT_QAM16	1@1	2503.5	0.60	4.55	27.76	23.81	240.436	Horizontal	Pass
		2592.99	0.73	4.69	27.72	23.76	237.684	Horizontal	Pass
		2682.48	1.01	4.72	27.7	23.99	250.611	Horizontal	Pass
20.0MHz DFT_QAM16	1@1	2506.02	0.56	4.55	27.77	23.78	238.781	Horizontal	Pass
		2592.99	0.64	4.69	27.72	23.67	232.809	Horizontal	Pass
		2679.99	1.01	4.72	27.69	23.98	250.035	Horizontal	Pass
40.0MHz DFT_QAM16	1@1	2516.01	0.15	4.57	27.78	23.36	216.770	Horizontal	Pass
		2592.99	0.12	4.73	27.72	23.11	204.644	Horizontal	Pass
		2670	0.61	4.75	27.68	23.54	225.944	Horizontal	Pass
50.0MHz DFT_QAM16	1@1	2521.02	0.35	4.54	27.75	23.56	226.986	Horizontal	Pass
		2592.99	0.34	4.69	27.72	23.37	217.270	Horizontal	Pass
		2664.99	0.49	4.71	27.71	23.49	223.357	Horizontal	Pass
60.0MHz DFT_QAM16	1@1	2526	0.19	4.55	27.76	23.40	218.776	Horizontal	Pass
		2592.99	0.27	4.69	27.72	23.30	213.796	Horizontal	Pass
		2659.98	0.55	4.72	27.7	23.53	225.424	Horizontal	Pass
80.0MHz DFT_QAM16	1@1	2536.02	0.03	4.55	27.77	23.25	211.349	Horizontal	Pass
		2592.99	0.08	4.69	27.72	23.11	204.644	Horizontal	Pass
		2649.99	0.11	4.72	27.69	23.08	203.236	Horizontal	Pass
90.0MHz DFT_QAM16	1@1	2541	-0.03	4.57	27.78	23.18	207.970	Horizontal	Pass
		2592.99	-0.02	4.73	27.72	22.97	198.153	Horizontal	Pass
		2644.98	-0.09	4.75	27.68	22.84	192.309	Horizontal	Pass
100.0MHz DFT_QAM16	1@1	2546.01	1.11	4.57	27.78	<b>24.32</b>	270.396	Horizontal	Pass
		2592.99	1.14	4.73	27.72	24.13	258.821	Horizontal	Pass
		2640	0.82	4.75	27.68	23.75	237.137	Horizontal	Pass

Radiated Power (EIRP) for Band 41 /SCS (30kHz)									
Mode	RB/ RB Position	Frequency	Result						Conclusion
			SG Level (dBm)	Cable Loss (dBm)	Factor Gain (dB)	Max. EIRP Average (dBm)	Max. EIRP Average (mW)	Polarization Of Max. ERP	
10.0MHz DFT_QAM16	1@1	2501.01	-0.84	4.54	27.75	22.37	172.584	Vertical	Pass
		2592.99	-0.70	4.69	27.72	22.33	171.002	Vertical	Pass
		2685	-0.91	4.71	27.71	22.09	161.808	Vertical	Pass
15.0MHz DFT_QAM16	1@1	2503.5	-0.85	4.55	27.76	22.36	172.187	Vertical	Pass
		2592.99	-0.54	4.69	27.72	22.49	177.419	Vertical	Pass
		2682.48	-0.82	4.72	27.7	22.16	164.437	Vertical	Pass
20.0MHz DFT_QAM16	1@1	2506.02	-0.80	4.55	27.77	22.42	174.582	Vertical	Pass
		2592.99	-0.78	4.69	27.72	22.25	167.880	Vertical	Pass
		2679.99	-0.91	4.72	27.69	22.06	160.694	Vertical	Pass
40.0MHz DFT_QAM16	1@1	2516.01	-1.08	4.57	27.78	22.13	163.305	Vertical	Pass
		2592.99	-0.26	4.73	27.72	22.73	187.499	Vertical	Pass
		2670	0.03	4.75	27.68	22.96	197.697	Vertical	Pass
50.0MHz DFT_QAM16	1@1	2521.02	-0.81	4.54	27.75	22.4	173.780	Vertical	Pass
		2592.99	-0.85	4.69	27.72	22.18	165.196	Vertical	Pass
		2664.99	-0.47	4.71	27.71	22.53	179.061	Vertical	Pass
60.0MHz DFT_QAM16	1@1	2526	-0.97	4.55	27.76	22.24	167.494	Vertical	Pass
		2592.99	-0.26	4.69	27.72	22.77	189.234	Vertical	Pass
		2659.98	-0.75	4.72	27.7	22.23	167.109	Vertical	Pass
80.0MHz DFT_QAM16	1@1	2536.02	-0.95	4.55	27.77	22.27	168.655	Vertical	Pass
		2592.99	-0.68	4.69	27.72	22.35	171.791	Vertical	Pass
		2649.99	-0.63	4.72	27.69	22.34	171.396	Vertical	Pass
90.0MHz DFT_QAM16	1@1	2541	-1.00	4.57	27.78	22.21	166.341	Vertical	Pass
		2592.99	-0.72	4.73	27.72	22.27	168.655	Vertical	Pass
		2644.98	-0.39	4.75	27.68	22.54	179.473	Vertical	Pass
100.0MHz DFT_QAM16	1@1	2546.01	-0.91	4.57	27.78	22.3	169.824	Vertical	Pass
		2592.99	-0.58	4.73	27.72	22.41	174.181	Vertical	Pass
		2640	-0.53	4.75	27.68	22.4	173.780	Vertical	Pass

Note:

SG Level= Signal generator output

Max. EIRP Average (dBm)= Factor Gain (dB)+ SG Level (dBm)- Cable Loss(dBm)

Factor Gain(dB)=Antenna Gain(dB) + Amplifier Factor (dB)



## 9. SPURIOUS RADIATION EMISSION

### RULE PART(S)

FCC: §2.1051, §27.53(c)(g)(h)(m)

### LIMIT

For Band 7, the minimum permissible attenuation level of any spurious emission is  $55 + \log_{10}(P)$  [Watts].

The minimum permissible attenuation level of any spurious emission is  $43 + \log_{10}(P)$  [Watts], where P is the transmitter power in Watts.

### TEST PROCEDURE

For Cellular equipment - Compliance with these rules is based on the use of measurement instrumentation employing a resolution bandwidth of 100 kHz or greater. In the 1 MHz bands immediately outside and adjacent to the frequency block a resolution bandwidth of at least one percent of the emission bandwidth of the fundamental emission of the transmitter may be employed. A narrower resolution bandwidth is permitted in all cases to improve measurement accuracy provided the measured power is integrated over the full required measurement bandwidth (i.e. 100 kHz or 1 percent of emission bandwidth, as specified). The emission bandwidth is defined as the width of the signal between two points, one below the carrier center frequency and one above the carrier center frequency, outside of which all emissions are attenuated at least 26 dB below the transmitter power.

For PCS equipment - Compliance with these rules is based on the use of measurement instrumentation employing a resolution bandwidth of 1 MHz or greater. However, in the 1 MHz bands immediately outside and adjacent to the frequency block a resolution bandwidth of at least one percent of the emission bandwidth of the fundamental emission of the transmitter may be employed. A narrower resolution bandwidth is permitted in all cases to improve measurement accuracy provided the measured power is integrated over the full required measurement bandwidth (i.e. 1 MHz or 1 percent of emission bandwidth, as specified). The emission bandwidth is defined as the width of the signal between two points, one below the carrier center frequency and one above the carrier center frequency, outside of which all emissions are attenuated at least 26 dB below the transmitter power.

The unwanted emission power shall be measured with a resolution bandwidth of at least 1% of the occupied bandwidth in the 1 MHz band immediately outside and adjacent to the channel edge of the equipment. Beyond the 1 MHz band immediately outside the channel edge of the equipment, a resolution bandwidth of 1 MHz shall be employed. A narrower resolution bandwidth is allowed to be used provided that the measured power is integrated over the full required measurement bandwidth of 1 MHz or 1% of the occupied bandwidth as applicable.

The power of any unwanted emissions measured from the channel edge of the equipment shall be attenuated below the transmitter power, P (dBW), as follows:

- a. for base station and subscriber equipment, other than mobile subscriber equipment, the attenuation shall not be less than  $43 + 10 \text{ Log}_{10}(p)$ , dB; and
- b. for mobile subscriber equipment, the attenuation shall not be less than  $43 + 10 \text{ Log}_{10}(p)$ , dB at the channel edges and  $55 + 10 \text{ Log}_{10}(p)$  at 5.5 MHz away and beyond the channel edges where p in (a) and (b) is the transmitter power measured in watts.

**MODES TESTED**

NR Band 5

NR Band 41

**RESULTS**

PASS

9.3 NR BAND 5

**QPSK EIRP POWER FOR NR BAND 5 (10MHZ BANDWIDTH/ SCS (30kHz))**

<b>Test Results for Low Channel 829MHz</b>							
Frequency(MHz)	SG Level(dBm)	Cable Loss(dB)	Antenna Gain(dB)	Absolute Level(dBm)	Limit (dBm)	Margin(dBm)	Polarity
1658	-48.97	2.78	27.50	-24.25	-13	-11.25	Horizontal
1658	-51.18	2.78	27.5	-26.46	-13	-13.46	Vertical
2487	-50.34	2.9	27.8	-25.44	-13	-12.44	Vertical
2487	-50.82	2.9	27.8	-25.92	-13	-12.92	Horizontal
185.8	-34.17	1.76	17.59	-18.34	-13	-5.34	Vertical
270.9	-42.95	1.63	15.87	-28.71	-13	-15.71	Horizontal
<b>Test Results For Mid Channel 836.5MHz</b>							
1673	-53.68	2.8	27.48	-29.00	-13	-16.00	Horizontal
1673	-46.69	2.8	27.48	-22.01	-13	-9.01	Vertical
2509.5	-46.11	2.91	27.7	-21.32	-13	-8.32	Vertical
2509.5	-51.88	2.91	27.7	-27.09	-13	-14.09	Horizontal
211.1	-41.27	1.61	15.68	-27.20	-13	-14.20	Vertical
456.1	-44.19	1.59	17.52	-28.26	-13	-15.26	Horizontal
<b>Test Results for High Channel 844MHz</b>							
1688	-52.93	2.82	27.43	-28.32	-13	-15.32	Horizontal
1688	-46.27	2.82	27.43	-21.66	-13	-8.66	Vertical
2532	-46.13	2.92	27.74	-21.31	-13	-8.31	Vertical
2532	-52.30	2.92	27.74	-27.48	-13	-14.48	Horizontal
188.3	-35.37	1.69	16.67	-20.39	-13	-7.39	Vertical
437.1	-42.41	1.7	17.18	-26.93	-13	-13.93	Horizontal

**QPSK EIRP POWER FOR NR BAND 5 (20MHZ BANDWIDTH/ SCS (30kHz))**

Test Results for Low Channel 834MHz							
Frequency(MHz)	SG Level(dBm)	Cable Loss(dB)	Antenna Gain(dB)	Absolute Level(dBm)	Limit (dBm)	Margin(dBm)	Polarity
1668	-47.94	2.78	27.5	-23.22	-13	-10.22	Horizontal
1668	-49.16	2.78	27.5	-24.44	-13	-11.44	Vertical
2502	-51.83	2.9	27.8	-26.93	-13	-13.93	Vertical
2502	-52.76	2.9	27.8	-27.86	-13	-14.86	Horizontal
176.2	-39.13	1.71	15.57	-25.27	-13	-12.27	Vertical
431.1	-42.01	1.34	16.4	-26.95	-13	-13.95	Horizontal
Test Results for Mid Channel 836.5MHz							
1673	-45.86	2.8	27.48	-21.18	-13	-8.18	Horizontal
1673	-48.24	2.8	27.48	-23.56	-13	-10.56	Vertical
2509.5	-53.68	2.91	27.7	-28.89	-13	-15.89	Vertical
2509.5	-50.60	2.91	27.7	-25.81	-13	-12.81	Horizontal
190.5	-38.06	1.44	17.04	-22.46	-13	-9.46	Vertical
357.6	-40.73	1.76	17.62	-24.87	-13	-11.87	Horizontal
Test Results for High Channel 839MHz							
1678	-46.98	2.82	27.43	-22.37	-13	-9.37	Horizontal
1678	-48.59	2.82	27.43	-23.98	-13	-10.98	Vertical
2517	-46.19	2.92	27.74	-21.37	-13	-8.37	Vertical
2517	-53.14	2.92	27.74	-28.32	-13	-15.32	Horizontal
211.8	-38.60	1.74	17.7	-22.64	-13	-9.64	Vertical
450.8	-43.10	1.41	17.46	-27.05	-13	-14.05	Horizontal

**16QAM EIRP POWER FOR NR BAND 5 (10MHZ BANDWIDTH/ SCS (30kHz))**

<b>Test Results for Low Channel 829MHz</b>							
Frequency(MHz)	SG Level(dBm)	Cable Loss(dB)	Antenna Gain(dB)	Absolute Level(dBm)	Limit (dBm)	Margin(dBm)	Polarity
1658	-45.33	2.78	27.5	-20.61	-13	-7.61	Horizontal
1658	-53.26	2.78	27.5	-28.54	-13	-15.54	Vertical
2487	-48.41	2.9	27.8	-23.51	-13	-10.51	Vertical
2487	-50.66	2.9	27.8	-25.76	-13	-12.76	Horizontal
201.5	-35.54	1.76	17.59	-19.71	-13	-6.71	Vertical
461.8	-44.42	1.63	15.87	-30.18	-13	-17.18	Horizontal
<b>Test Results For Mid Channel 836.5MHz</b>							
1673	-52.55	2.8	27.48	-27.87	-13	-14.87	Horizontal
1673	-44.19	2.8	27.48	-19.51	-13	-6.51	Vertical
2509.5	-51.18	2.91	27.7	-26.39	-13	-13.39	Vertical
2509.5	-50.96	2.91	27.7	-26.17	-13	-13.17	Horizontal
195.8	-42.95	1.61	15.68	-28.88	-13	-15.88	Vertical
353.5	-38.26	1.59	17.52	-22.33	-13	-9.33	Horizontal
<b>Test Results for High Channel 844MHz</b>							
1688	-51.41	2.82	27.43	-26.80	-13	-13.80	Horizontal
1688	-45.59	2.82	27.43	-20.98	-13	-7.98	Vertical
2532	-51.75	2.92	27.74	-26.93	-13	-13.93	Vertical
2532	-53.72	2.92	27.74	-28.90	-13	-15.90	Horizontal
212.1	-37.81	1.69	16.67	-22.83	-13	-9.83	Vertical
343.7	-44.32	1.7	17.18	-28.84	-13	-15.84	Horizontal

**16QAM EIRP POWER FOR NR BAND 5 (20MHZ BANDWIDTH/ SCS (30kHz))**

Test Results for Low Channel 834MHz							
Frequency(MHz)	SG Level(dBm)	Cable Loss(dB)	Antenna Gain(dB)	Absolute Level(dBm)	Limit (dBm)	Margin(dBm)	Polarity
1668	-51.71	2.78	27.5	-26.99	-13	-13.99	Horizontal
1668	-53.96	2.78	27.5	-29.24	-13	-16.24	Vertical
2502	-47.86	2.9	27.8	-22.96	-13	-9.96	Vertical
2502	-53.39	2.9	27.8	-28.49	-13	-15.49	Horizontal
198.6	-34.47	1.71	15.57	-20.61	-13	-7.61	Vertical
336.2	-42.88	1.34	16.4	-27.82	-13	-14.82	Horizontal
Test Results for Mid Channel 836.5MHz							
1673	-50.68	2.8	27.48	-26.00	-13	-13.00	Horizontal
1673	-47.51	2.8	27.48	-22.83	-13	-9.83	Vertical
2509.5	-48.86	2.91	27.7	-24.07	-13	-11.07	Vertical
2509.5	-50.70	2.91	27.7	-25.91	-13	-12.91	Horizontal
195.4	-40.75	1.44	17.04	-25.15	-13	-12.15	Vertical
270.1	-34.68	1.76	17.62	-18.82	-13	-5.82	Horizontal
Test Results for High Channel 839MHz							
1678	-46.05	2.82	27.43	-21.44	-13	-8.44	Horizontal
1678	-48.64	2.82	27.43	-24.03	-13	-11.03	Vertical
2517	-48.79	2.92	27.74	-23.97	-13	-10.97	Vertical
2517	-51.57	2.92	27.74	-26.75	-13	-13.75	Horizontal
209.2	-34.27	1.74	17.7	-18.31	-13	-5.31	Vertical
339	-37.55	1.41	17.46	-21.50	-13	-8.50	Horizontal

Note: P<sub>Mea</sub>(dBm)= Power(dBm)+ AR<sub>pl</sub> (dBm)  
 Over Limit= : P<sub>Mea</sub>(dBm)-Limit(dBm)

9.4 NR BAND 41

**QPSK EIRP POWER FOR NR BAND 41 (10.0MHZ BANDWIDTH/ SCS (30kHz))**

<b>Test Results for Low Channel 2501.01MHz</b>							
Frequency(MHz)	SG Level(dBm)	Cable Loss(dB)	Antenna Gain(dB)	Absolute Level(dBm)	Limit (dBm)	Margin(dBm)	Polarity
5002.02	-60.21	2.63	27.3	-35.54	-25	-10.54	Horizontal
5002.02	-64.85	2.63	27.3	-40.18	-25	-15.18	Vertical
7503.3	-62.66	3.38	28.51	-37.53	-25	-12.53	Vertical
7503.3	-63.38	3.38	28.51	-38.25	-25	-13.25	Horizontal
182.2	-46.49	1.73	17.97	-30.25	-25	-5.25	Vertical
284.5	-50.28	1.38	15.11	-36.55	-25	-11.55	Horizontal
<b>Test Results for Mid Channel 2592.99MHz</b>							
5185.98	-65.00	2.65	27.32	-40.33	-25	-15.33	Horizontal
5185.98	-60.94	2.65	27.32	-36.27	-25	-11.27	Vertical
7778.97	-63.94	4.14	28.51	-39.57	-25	-14.57	Vertical
7778.97	-63.75	4.14	28.51	-39.38	-25	-14.38	Horizontal
180.9	-50.02	1.77	16.17	-35.62	-25	-10.62	Vertical
405.1	-44.77	1.63	15.21	-31.19	-25	-6.19	Horizontal
<b>Test Results for High Channel 2685MHz</b>							
5370	-59.04	2.65	27.32	-31.87	-25	-6.87	Horizontal
5370	-63.04	2.65	27.32	-32.26	-25	-7.26	Vertical
8055	-63.87	5.23	28.89	-32.02	-25	-7.02	Vertical
8055	-61.06	5.23	28.89	-29.06	-25	-4.06	Horizontal
196.2	-46.71	1.58	17.56	-32.38	-25	-7.38	Vertical
380.4	-47.26	1.45	16.58	-31.12	-25	-6.12	Horizontal

**QPSK EIRP POWER FOR NR BAND 41 (100.0MHZ BANDWIDTH/ SCS (30kHz))**

Test Results for Low Channel 2546.01MHz							
Frequency(MHz)	SG Level(dBm)	Cable Loss(dB)	Antenna Gain(dB)	Absolute Level(dBm)	Limit (dBm)	Margin(dBm)	Polarity
5092.02	-63.96	2.63	27.3	-39.29	-25	-14.29	Horizontal
5092.02	-62.15	2.63	27.3	-37.48	-25	-12.48	Vertical
7638.03	-64.37	3.38	28.51	-39.24	-25	-14.24	Vertical
7638.03	-62.06	3.38	28.51	-36.93	-25	-11.93	Horizontal
181.2	-51.75	1.63	15.76	-37.62	-25	-12.62	Vertical
436.4	-54.55	1.71	15.44	-40.82	-25	-15.82	Horizontal
Test Results for Mid Channel 2592.99MHz							
5185.98	-62.31	2.65	27.32	-37.64	-25	-12.64	Horizontal
5185.98	-60.06	2.65	27.32	-35.39	-25	-10.39	Vertical
7778.97	-63.13	4.14	28.51	-38.76	-25	-13.76	Vertical
7778.97	-64.48	4.14	28.51	-40.11	-25	-15.11	Horizontal
198.9	-48.93	1.79	16.84	-33.88	-25	-8.88	Vertical
325.1	-51.97	1.71	17.64	-36.04	-25	-11.04	Horizontal
Test Results for High Channel 2640MHz							
5280	-59.33	2.65	27.32	-34.66	-25	-9.66	Horizontal
5280	-60.46	2.65	27.32	-35.79	-25	-10.79	Vertical
7920	-64.58	5.23	28.89	-40.92	-25	-15.92	Vertical
7920	-62.21	5.23	28.89	-38.55	-25	-13.55	Horizontal
189.5	-53.31	1.79	16.84	-38.26	-25	-13.26	Vertical
253.1	-45.94	1.71	17.64	-30.01	-25	-5.01	Horizontal



**16QAM EIRP POWER FOR NR BAND 41 (10.0MHZ BANDWIDTH/ SCS (30kHz))**

<b>Test Results for Low Channel 2501.01MHz</b>							
Frequency(MHz)	SG Level(dBm)	Cable Loss(dB)	Antenna Gain(dB)	Absolute Level(dBm)	Limit (dBm)	Margin(dBm)	Polarity
5002.02	-62.50	2.63	27.3	-37.83	-25	-12.83	Horizontal
5002.02	-61.25	2.63	27.3	-36.58	-25	-11.58	Vertical
7503.3	-62.93	3.38	28.51	-37.80	-25	-12.80	Vertical
7503.3	-60.15	3.38	28.51	-35.02	-25	-10.02	Horizontal
198.4	-47.25	1.73	17.97	-31.01	-25	-6.01	Vertical
425.3	-51.22	1.38	15.11	-37.49	-25	-12.49	Horizontal
<b>Test Results for Mid Channel 2592.99MHz</b>							
5185.98	-63.05	2.65	27.32	-38.38	-25	-13.38	Horizontal
5185.98	-63.39	2.65	27.32	-38.72	-25	-13.72	Vertical
7778.97	-64.03	4.14	28.51	-39.66	-25	-14.66	Vertical
7778.97	-59.75	4.14	28.51	-35.38	-25	-10.38	Horizontal
201	-46.43	1.77	16.17	-32.03	-25	-7.03	Vertical
433.9	-47.25	1.63	15.21	-33.67	-25	-8.67	Horizontal
<b>Test Results for High Channel 2685MHz</b>							
5370	-59.46	2.65	27.32	-34.79	-25	-9.79	Horizontal
5370	-61.61	2.65	27.32	-36.94	-25	-11.94	Vertical
8055	-60.60	5.23	28.89	-36.94	-25	-11.94	Vertical
8055	-62.71	5.23	28.89	-39.05	-25	-14.05	Horizontal
188.8	-50.09	1.58	17.56	-34.11	-25	-9.11	Vertical
370.2	-48.50	1.45	16.58	-33.37	-25	-8.37	Horizontal

**16QAM EIRP POWER FOR NR BAND 51 (100.0MHZ BANDWIDTH/ SCS (30kHz))**

Test Results for Low Channel 2546.01MHz							
Frequency(MHz)	SG Level(dBm)	Cable Loss(dB)	Antenna Gain(dB)	Absolute Level(dBm)	Limit (dBm)	Margin(dBm)	Polarity
5092.02	-62.57	2.63	27.3	-37.90	-25	-12.90	Horizontal
5092.02	-64.32	2.63	27.3	-39.65	-25	-14.65	Vertical
7638.03	-61.86	3.38	28.51	-36.73	-25	-11.73	Vertical
7638.03	-59.41	3.38	28.51	-34.28	-25	-9.28	Horizontal
202.5	-52.56	1.63	15.76	-38.43	-25	-13.43	Vertical
438.1	-47.35	1.71	15.44	-33.62	-25	-8.62	Horizontal
Test Results for Mid Channel 2592.99MHz							
5185.98	-62.97	2.65	27.32	-38.30	-25	-13.30	Horizontal
5185.98	-59.10	2.65	27.32	-34.43	-25	-9.43	Vertical
7778.97	-59.33	4.14	28.51	-34.96	-25	-9.96	Vertical
7778.97	-61.82	4.14	28.51	-37.45	-25	-12.45	Horizontal
200.9	-46.59	1.79	16.84	-31.54	-25	-6.54	Vertical
459.3	-50.52	1.71	17.64	-34.59	-25	-9.59	Horizontal
Test Results for High Channel 2640MHz							
5280	-64.26	2.65	27.32	-39.59	-25	-14.59	Horizontal
5280	-60.08	2.65	27.32	-35.41	-25	-10.41	Vertical
7920	-64.74	5.23	28.89	-41.08	-25	-16.08	Vertical
7920	-63.62	5.23	28.89	-39.96	-25	-14.96	Horizontal
198.8	-54.86	1.79	16.84	-39.81	-25	-14.81	Vertical
297.5	-52.42	1.71	17.64	-36.49	-25	-11.49	Horizontal

Note: P<sub>Mea</sub>(dBm)= Power(dBm)+ ARpl (dBm)  
 Over Limit= : P<sub>Mea</sub>(dBm)-Limit(dBm)

## 10. FREQUENCY STABILITY

### RULE PART(S)

FCC: §2.1055, §27.54

### LIMITS

§22.355 - The carrier frequency shall not depart from the reference frequency in excess of  $\pm 2.5$  ppm for mobile stations.

§24.235 - The frequency stability shall be sufficient to ensure that the fundamental emission stays within the authorized frequency block.

### TEST PROCEDURE

Use CMW 500 with Frequency Error measurement capability.

Temp. =  $-30^{\circ}$  to  $+50^{\circ}$ C

Voltage = low voltage, DC 3.4V, Normal, DC 3.85V and High voltage, DC 4.2V.

### Frequency Stability vs Temperature:

The EUT is placed inside a temperature chamber. The temperature is set to  $-30^{\circ}$ C and allowed to stabilize. After sufficient soak time, the transmitting frequency error is measured. The temperature is increased by 10 degrees, allowed to stabilize and soak, and then the measurement is repeated. This is repeated until  $+50^{\circ}$ C is reached.

### Frequency Stability vs Voltage:

The peak frequency error is recorded (worst-case).

### MODES TESTED

NR Band 5

NR Band 41

### RESULTS

See the following pages.

10.3 NR BAND 5

DFT\_QPSK, (20MHz BANDWIDTH)

**Frequency error vs. Voltage**

Voltage [Vdc]	Frequency [MHz]	Frequency* Error[Hz]	Frequency Error[ppm]	Limit [ppm]
<b>BAND 5 DFT_QPSK, (CH 167300 1@1 20MHz BANDWIDTH)</b>				
3.4	836.5	2.03	0.002427	2.5
3.85	836.5	4.49	0.005368	2.5
4.4	836.5	5.61	0.006707	2.5

**Frequency error vs. Temperature**

Temperature [° C]	Frequency [MHz]	Frequency* Error[Hz]	Frequency Error[ppm]	Limit [ppm]
<b>BAND 5 DFT_QPSK, (CH 167300 1@1 20MHz BANDWIDTH)</b>				
Normal (25C)	836.5	3.42	0.004088	2.5
Extreme (50C)	836.5	11.73	0.014023	2.5
Extreme (40C)	836.5	9.31	0.011130	2.5
Extreme (30C)	836.5	5.49	0.006563	2.5
Extreme (10C)	836.5	7.55	0.009026	2.5
Extreme (0C)	836.5	8.15	0.009743	2.5
Extreme (-10C)	836.5	8.54	0.010209	2.5
Extreme (-20C)	836.5	11.55	0.013808	2.5
Extreme (-30C)	836.5	10.68	0.012767	2.5

**DFT\_QAM16, (20MHz BANDWIDTH)**

**Frequency error vs. Voltage**

Voltage [Vdc]	Frequency [MHz]	Frequency* Error[Hz]	Frequency Error[ppm]	Limit [ppm]
<b>BAND 5 DFT_QAM16, (CH 167300 1@1 20MHz BANDWIDTH)</b>				
3.4	836.5	4.55	0.005439	2.5
3.85	836.5	5.04	0.006025	2.5
4.4	836.5	7.13	0.008524	2.5

**Frequency error vs. Temperature**

Temperature [° C]	Frequency [MHz]	Frequency* Error[Hz]	Frequency Error[ppm]	Limit [ppm]
<b>BAND 5 DFT_QAM16, (CH 167300 1@1 20MHz BANDWIDTH)</b>				
Normal (25C)	836.5	3.8	0.004543	2.5
Extreme (50C)	836.5	11.33	0.013545	2.5
Extreme (40C)	836.5	8.5	0.010161	2.5
Extreme (30C)	836.5	4.1	0.004901	2.5
Extreme (10C)	836.5	5.78	0.006910	2.5
Extreme (0C)	836.5	7.19	0.008595	2.5
Extreme (-10C)	836.5	9.03	0.010795	2.5
Extreme (-20C)	836.5	10.51	0.012564	2.5
Extreme (-30C)	836.5	10.26	0.012265	2.5

**\*Note:** Frequency error measurements were made by using the build-in capability of the Wireless Communication Test Set.

10.4 NR BAND 41

DFT\_QPSK, (100MHz BANDWIDTH)

Frequency error vs. Voltage

Voltage [Vdc]	Frequency [MHz]	Frequency* Error[Hz]	Frequency Error[ppm]	Limit [ppm]
<b>BAND 41 DFT_QPSK, (CH 518598 1@1 100MHz BANDWIDTH)</b>				
3.4	2592.99	3.84	0.001481	2.5
3.85	2592.99	5.94	0.002291	2.5
4.4	2592.99	7.78	0.003000	2.5

Frequency error vs. Temperature

Temperature [° C]	Frequency [MHz]	Frequency* Error[Hz]	Frequency Error[ppm]	Limit [ppm]
<b>BAND 41 DFT_QPSK, (CH 518598 1@1 100MHz BANDWIDTH)</b>				
Normal (25C)	2592.99	2.63	0.001014	2.5
Extreme (50C)	2592.99	11.77	0.004539	2.5
Extreme (40C)	2592.99	9.71	0.003745	2.5
Extreme (30C)	2592.99	5.15	0.001986	2.5
Extreme (10C)	2592.99	5.42	0.002090	2.5
Extreme (0C)	2592.99	8.17	0.003151	2.5
Extreme (-10C)	2592.99	8.06	0.003108	2.5
Extreme (-20C)	2592.99	11.99	0.004624	2.5
Extreme (-30C)	2592.99	11.3	0.004358	2.5

**DFT\_QAM16, (100MHz BANDWIDTH)**

**Frequency error vs. Voltage**

Voltage [Vdc]	Frequency [MHz]	Frequency* Error[Hz]	Frequency Error[ppm]	Limit [ppm]
<b>BAND 41 DFT_QAM16, (CH 518598 1@1 100MHz BANDWIDTH)</b>				
3.4	2592.99	2.66	0.001026	2.5
3.85	2592.99	5.43	0.002094	2.5
4.4	2592.99	5.09	0.001963	2.5

**Frequency error vs. Temperature**

Temperature [° C]	Frequency [MHz]	Frequency* Error[Hz]	Frequency Error[ppm]	Limit [ppm]
<b>BAND 41 DFT_QAM16, (CH 518598 1@1 100MHz BANDWIDTH)</b>				
Normal (25C)	2592.99	2.58	0.000995	2.5
Extreme (50C)	2592.99	13.41	0.005172	2.5
Extreme (40C)	2592.99	9.48	0.003656	2.5
Extreme (30C)	2592.99	4.51	0.001739	2.5
Extreme (10C)	2592.99	5.58	0.002152	2.5
Extreme (0C)	2592.99	7.66	0.002954	2.5
Extreme (-10C)	2592.99	8.5	0.003278	2.5
Extreme (-20C)	2592.99	10.47	0.004038	2.5
Extreme (-30C)	2592.99	10.41	0.004015	2.5

**\*Note:** Frequency error measurements were made by using the build-in capability of the Wireless Communication Test Set.

## 11. Peak-to-Average Ratio

### 11.1 Description of the PAR Measurement

The peak-to-average ratio (PAR) of the transmission may not exceed 13 dB.

### 11.2 Measuring Instruments

See list of measuring instruments of this test report.

### 11.3 Test Procedures

1. The EUT was connected to Spectrum Analyzer and Base Station via power divider.
2. The RF output of EUT was connected to the spectrum analyzer by RF cable and attenuator. The path loss was compensated to the results for each measurement.
3. For GSM/EGPRS operating modes:
  - a. Set the RBW = 1MHz, VBW = 1MHz, Peak detector in spectrum analyzer.
  - b. Set EUT in maximum power output, and triggered the burst signal.
  - c. Measured respectively the Peak level and Mean level, and the deviation was recorded as Peak to Average Ratio.
4. For UMTS operating modes:
  - a. Set the CCDF (Complementary Cumulative Distribution Function) option in spectrum analyzer.
  - b. The highest RF powers were measured and recorded the maximum PAPR level associated with a probability of 0.1 %.

### 11.4 Test Setup

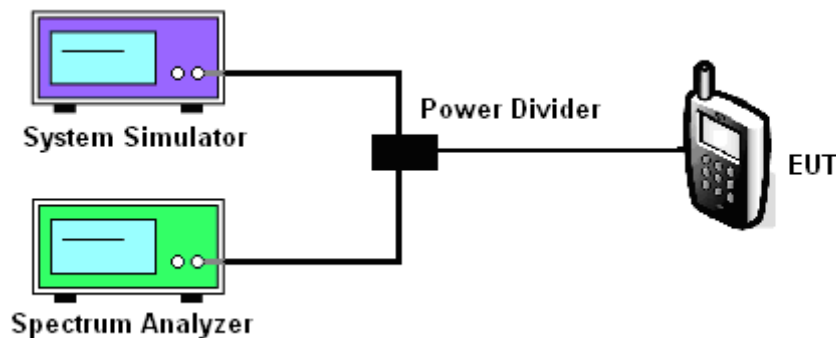

### MODES TESTED

NR Band 5/41

Test data reference attachment.

----END OF REPORT----