

GSM850 Channel=251

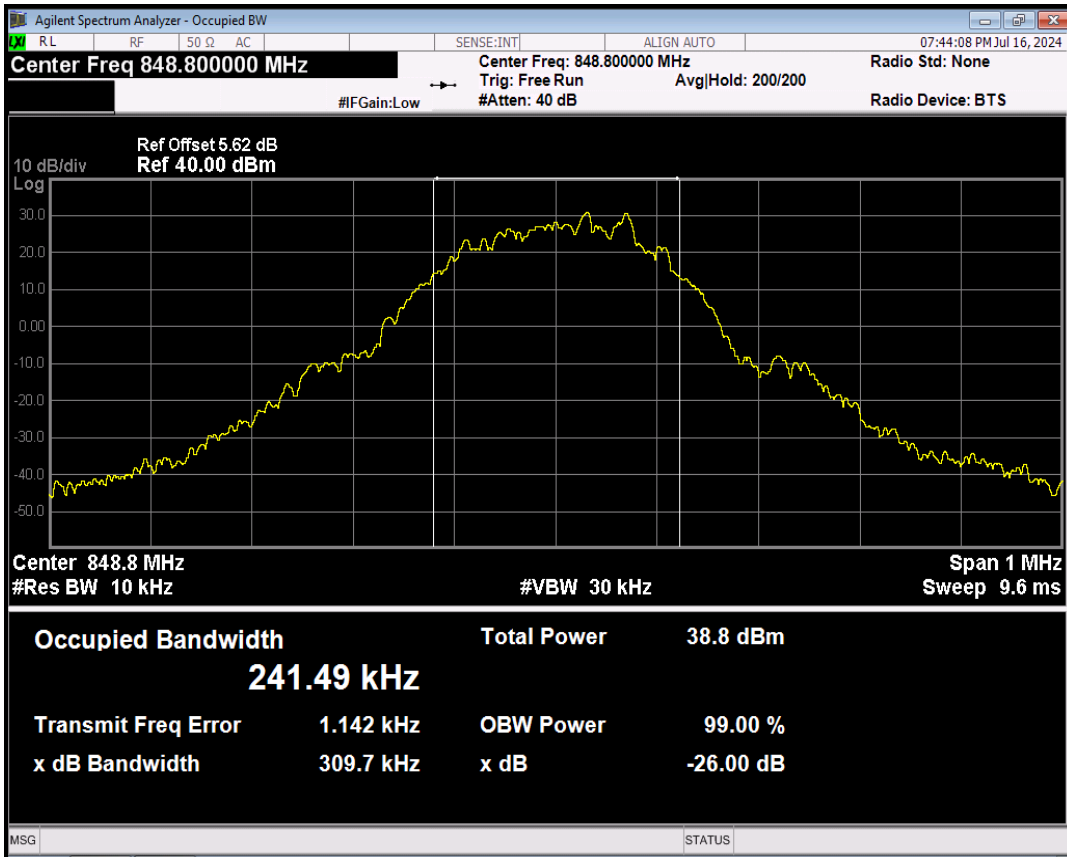

GPRS850 Channel=128

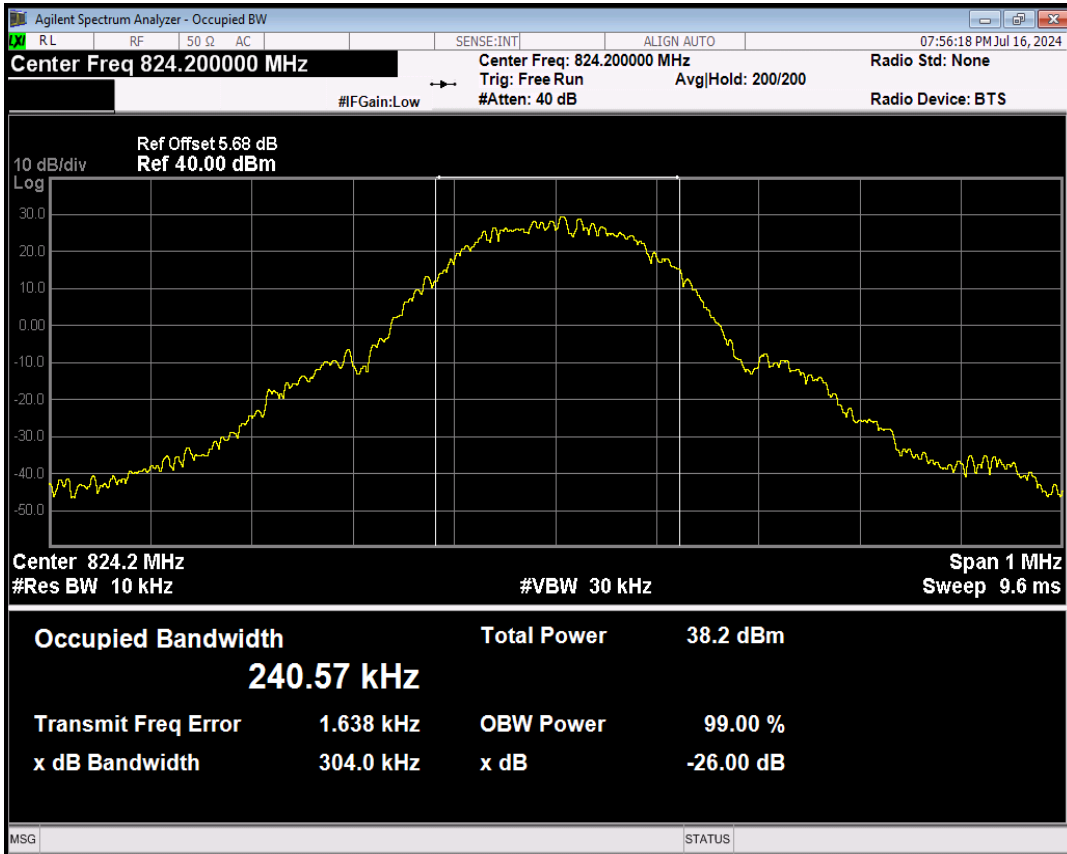

GPRS850 Channel=190

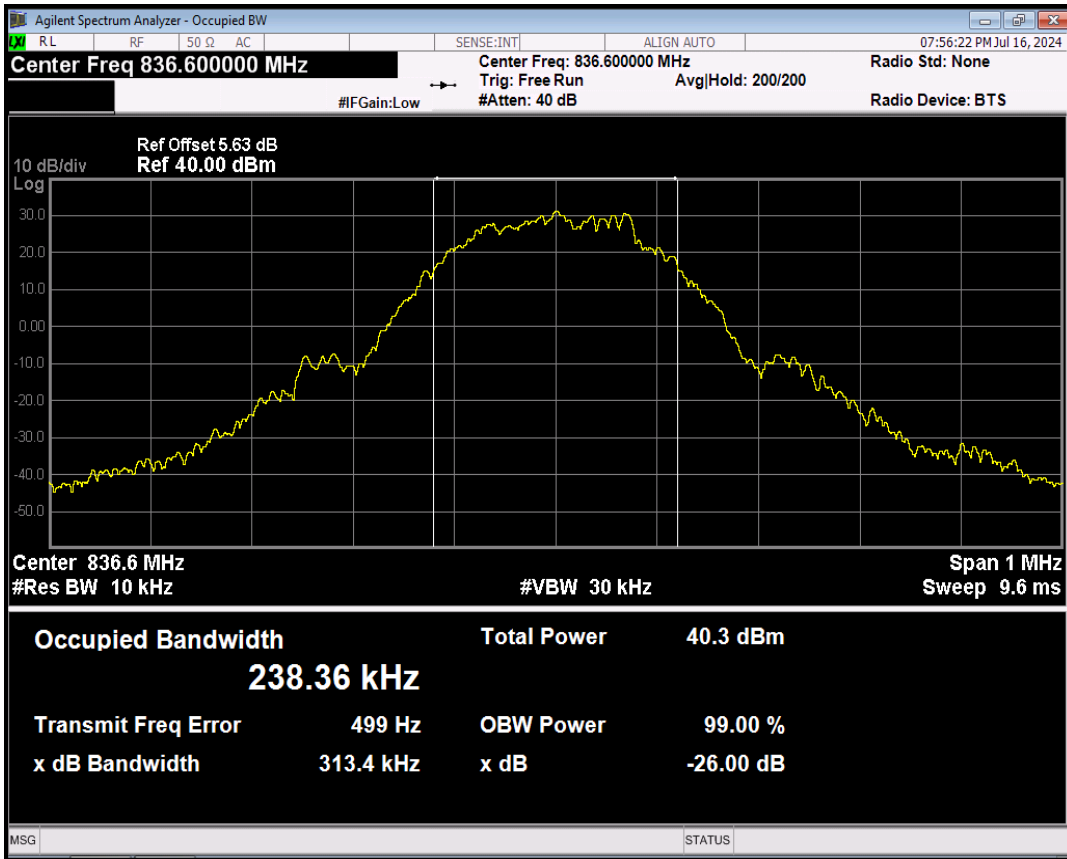

GPRS850 Channel=251

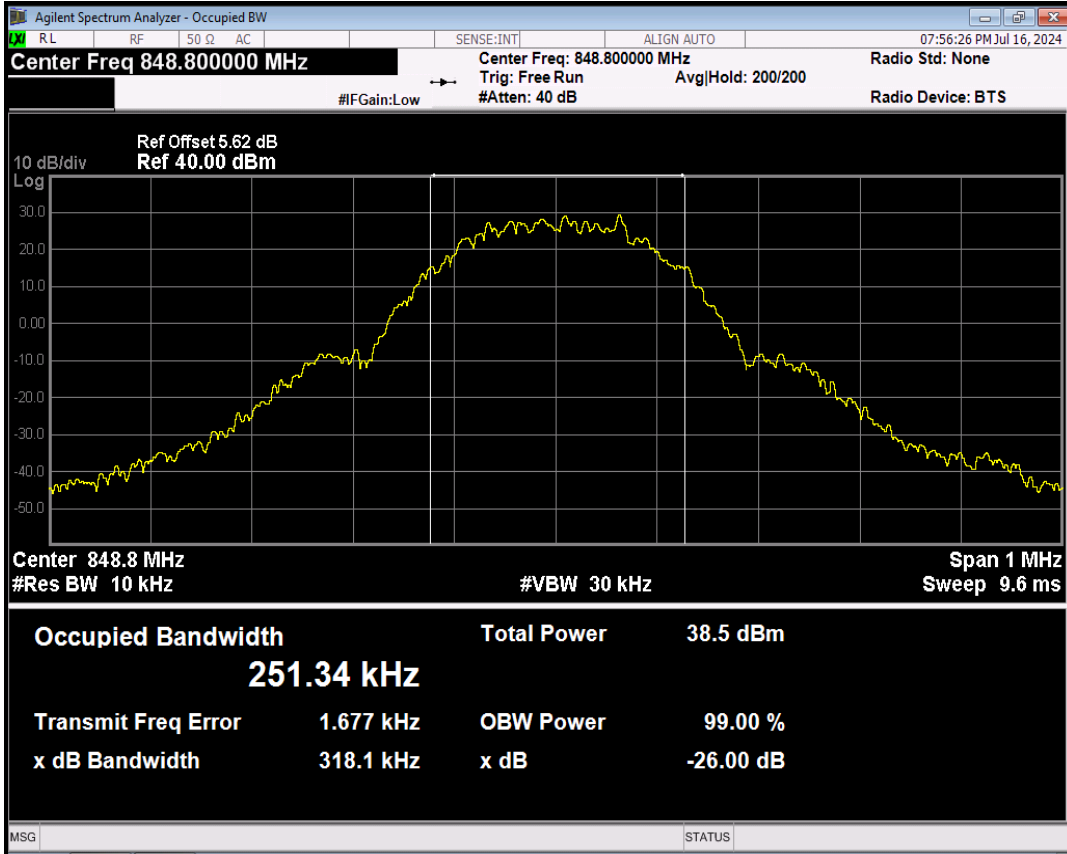

EGPRS850 Channel=128

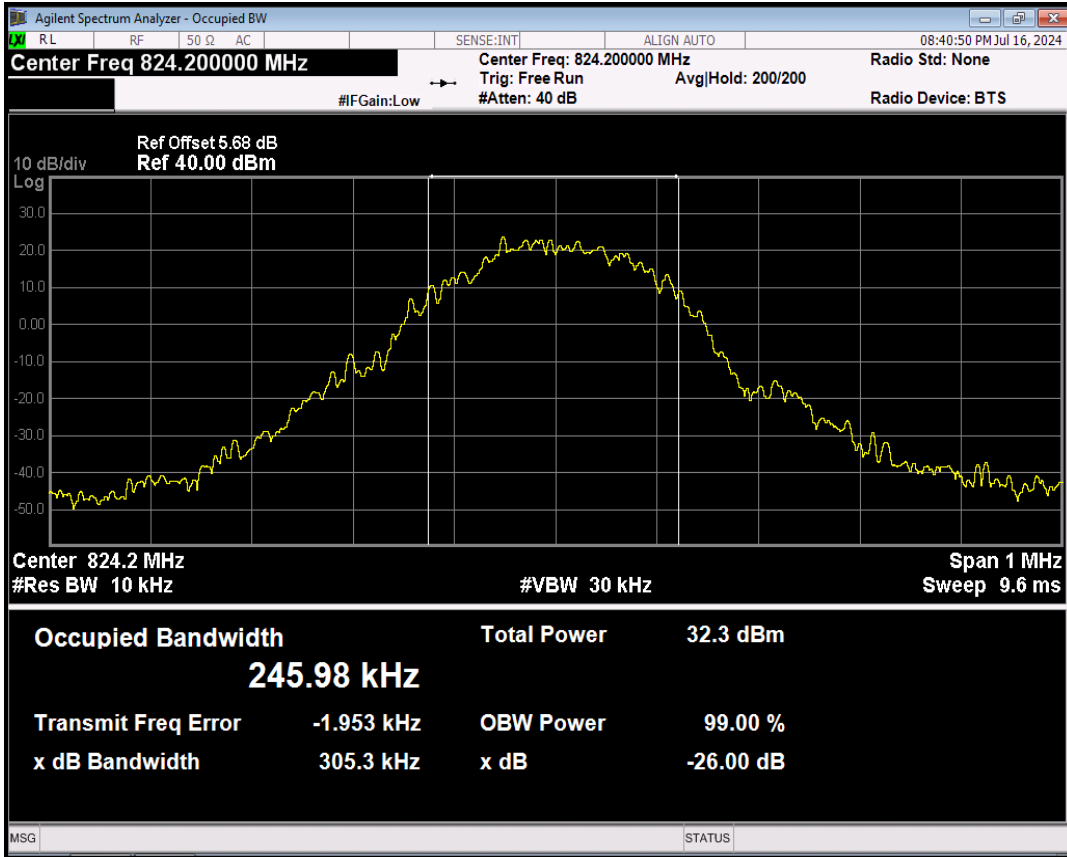

EGPRS850 Channel=190

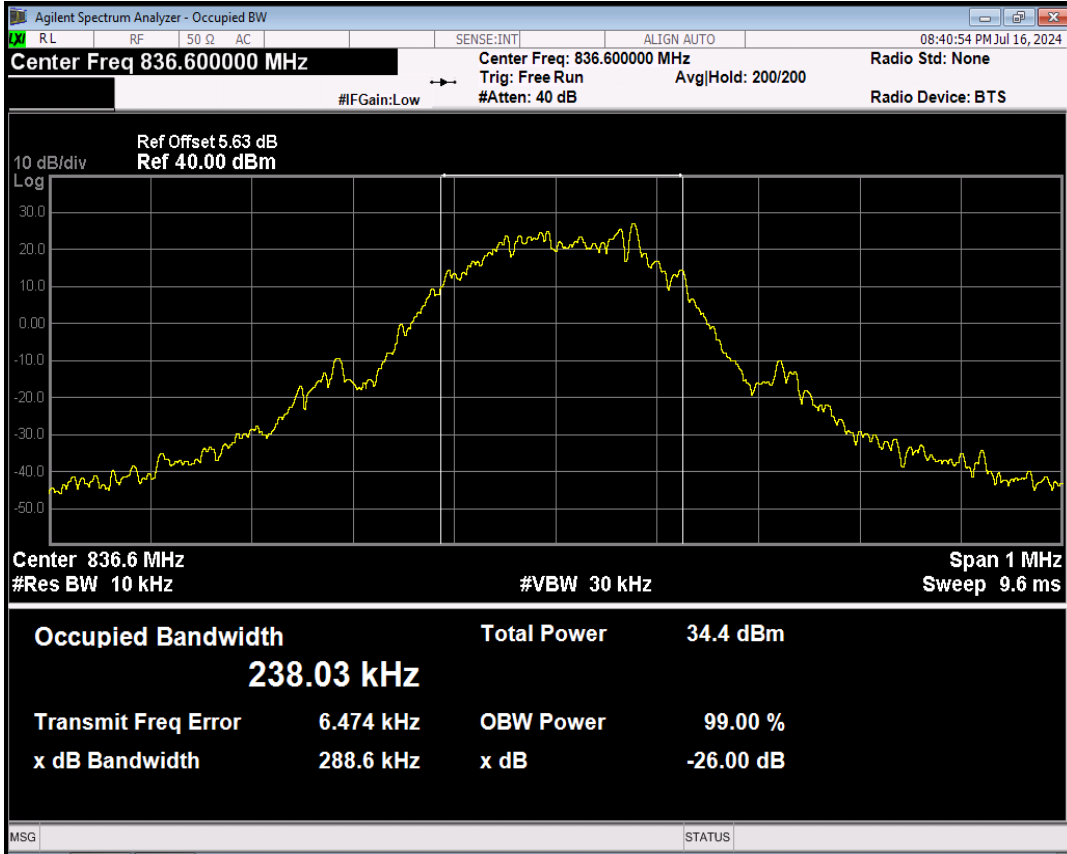

EGPRS850 Channel=251

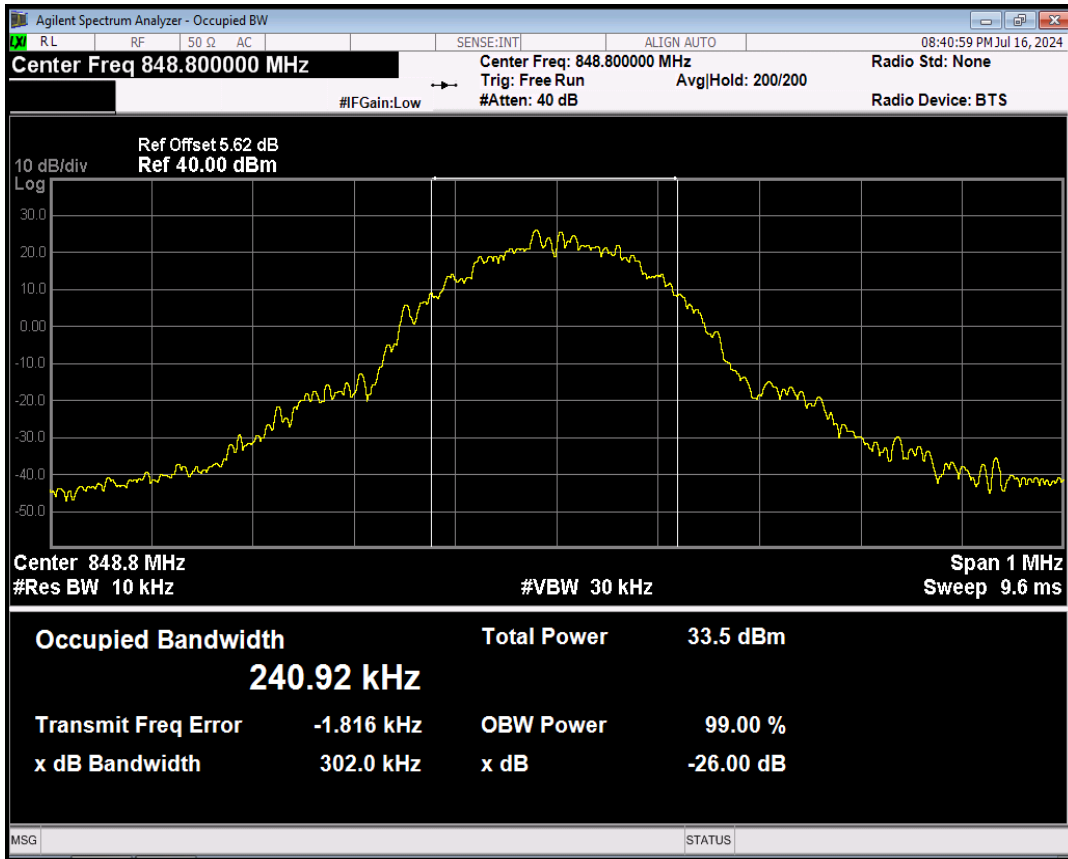

Band	Channel	Frequency (MHz)	99% OBW (kHz)	-26dB EBW (kHz)	Verdict
GSM1900	512	1850.2	242.652	301.460	PASS
GSM1900	661	1880	239.818	310.241	PASS
GSM1900	810	1909.8	240.949	303.264	PASS
GPRS1900	512	1850.2	245.198	315.548	PASS
GPRS1900	661	1880	244.397	307.033	PASS
GPRS1900	810	1909.8	246.757	316.763	PASS
EGPRS1900	512	1850.2	251.289	306.660	PASS
EGPRS1900	661	1880	239.682	317.972	PASS
EGPRS1900	810	1909.8	239.886	312.709	PASS

GSM1900 Channel=512

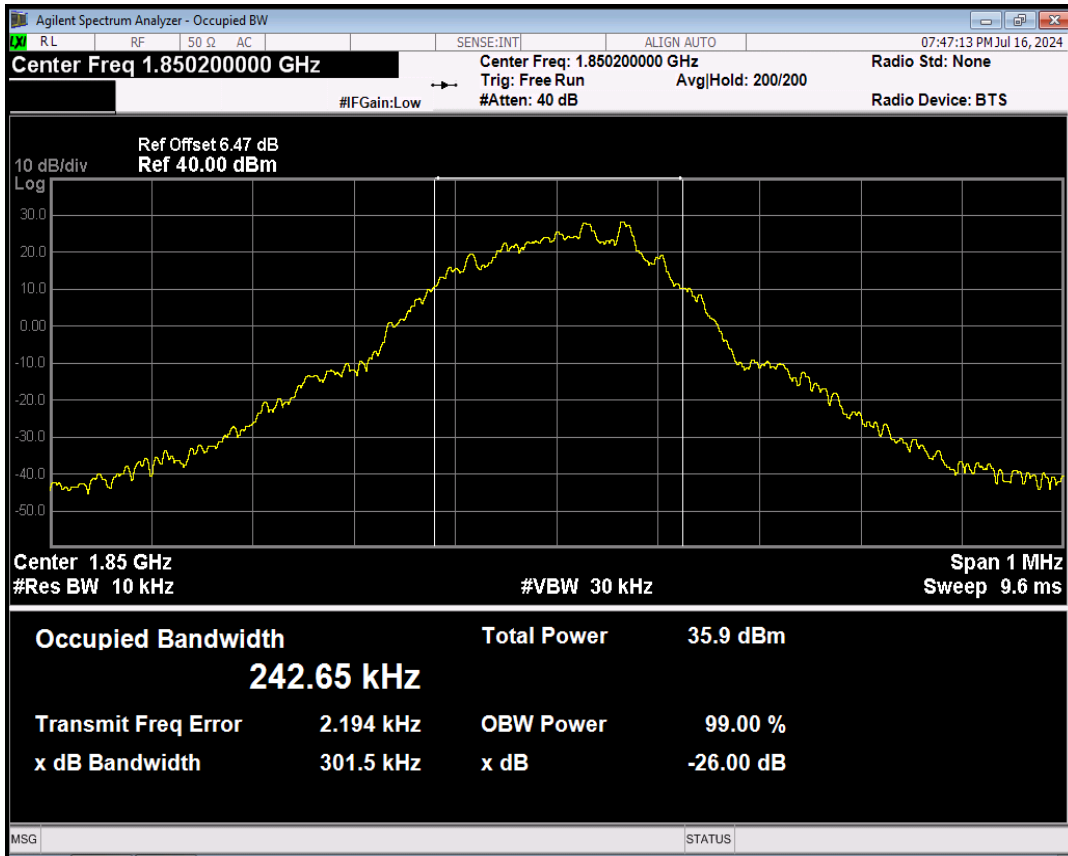

GSM1900 Channel=661

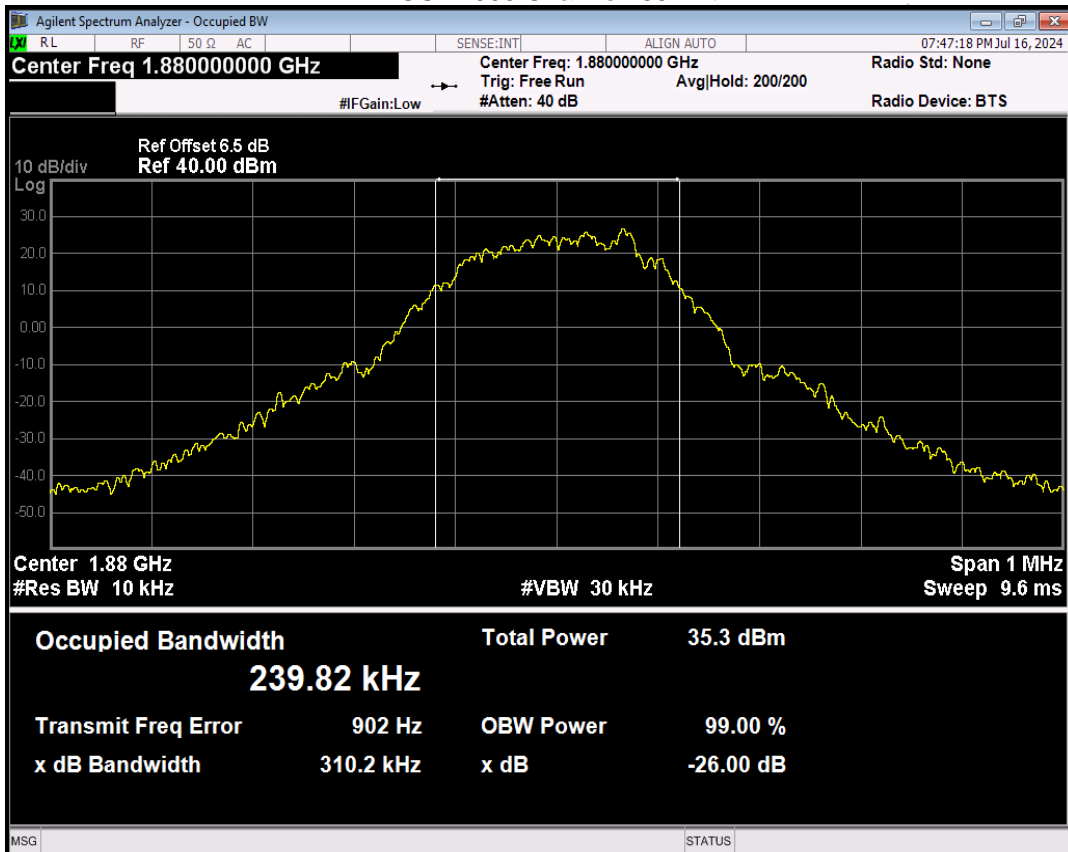

GSM1900 Channel=810

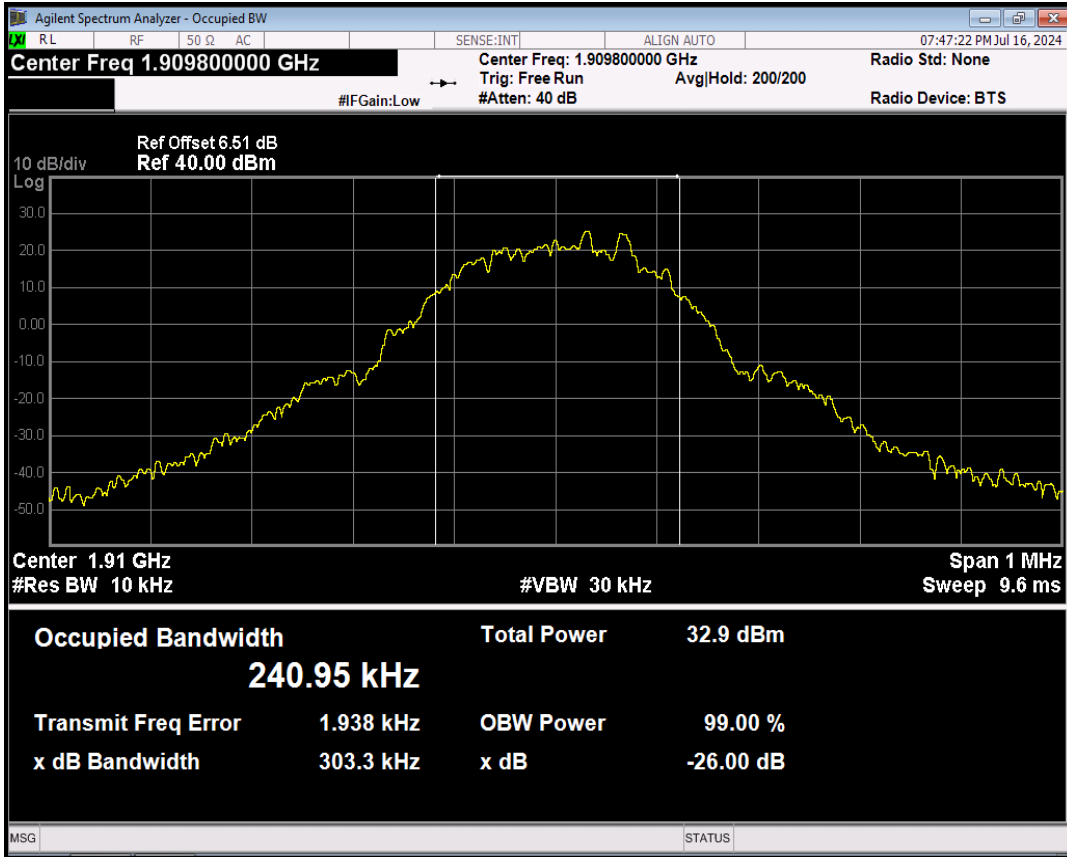

GPRS1900 Channel=512

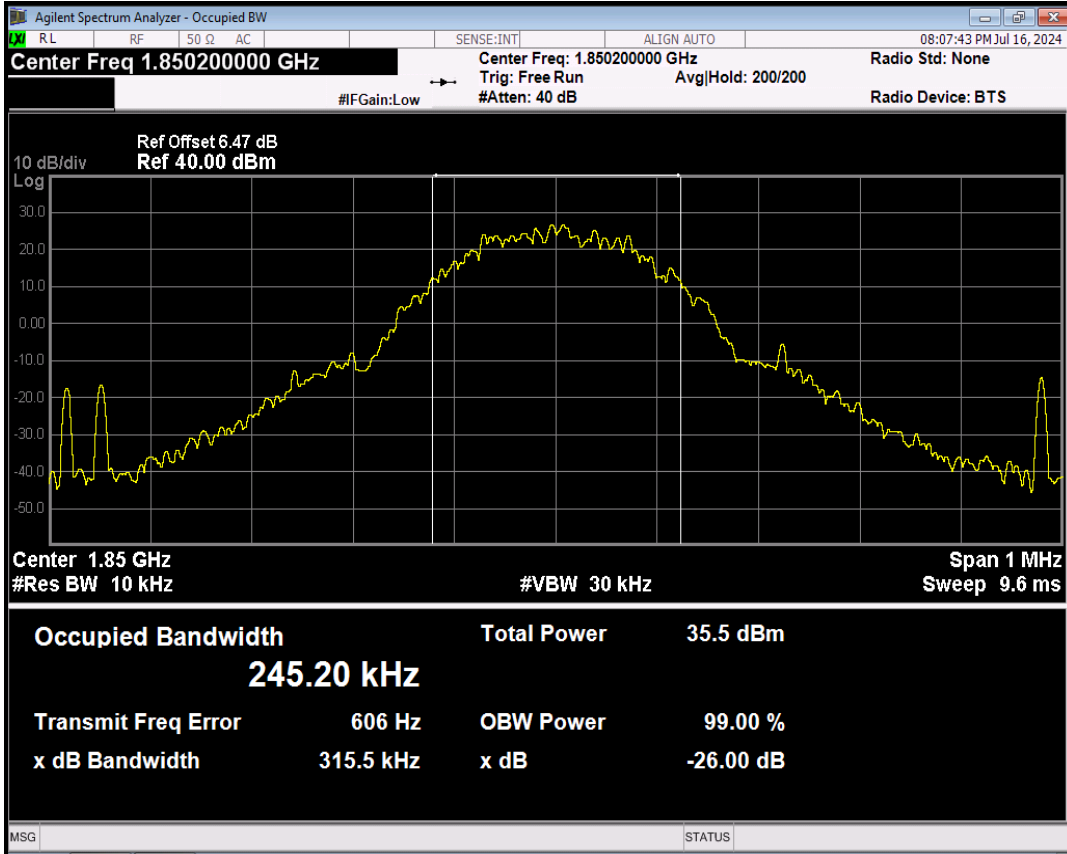

GPRS1900 Channel=661

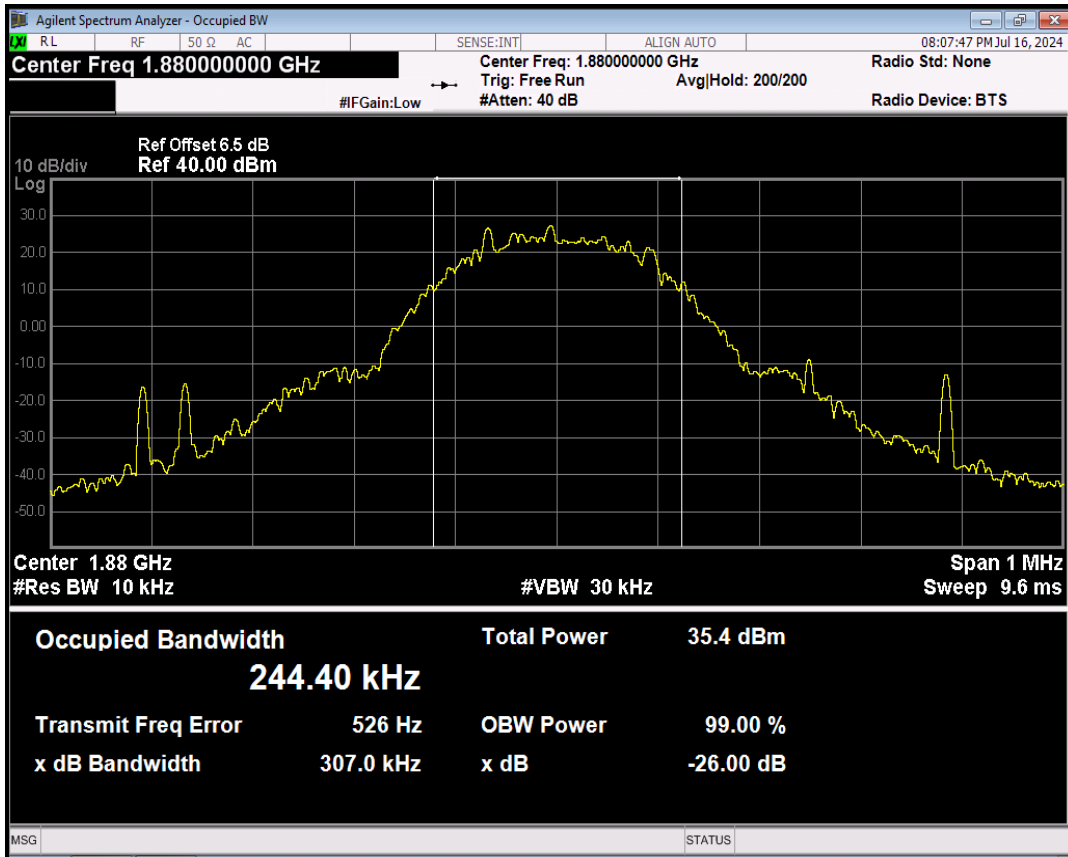

GPRS1900 Channel=810

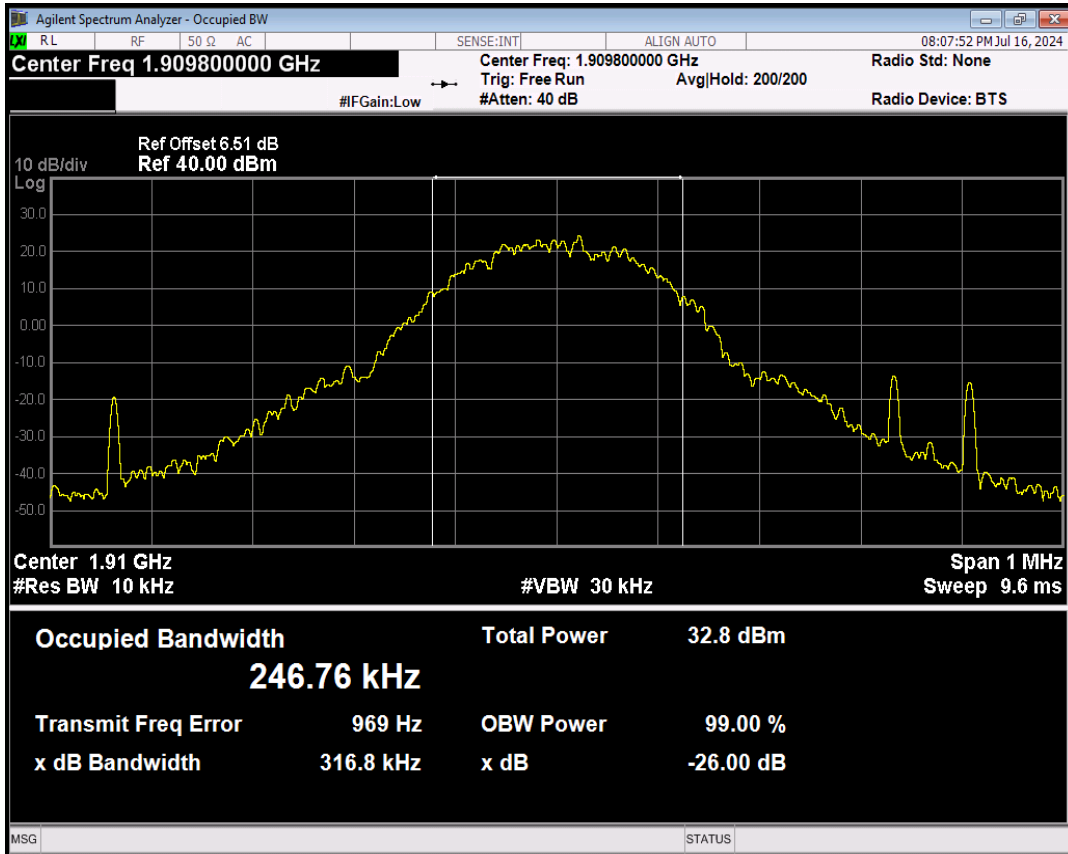

EGPRS1900 Channel=512

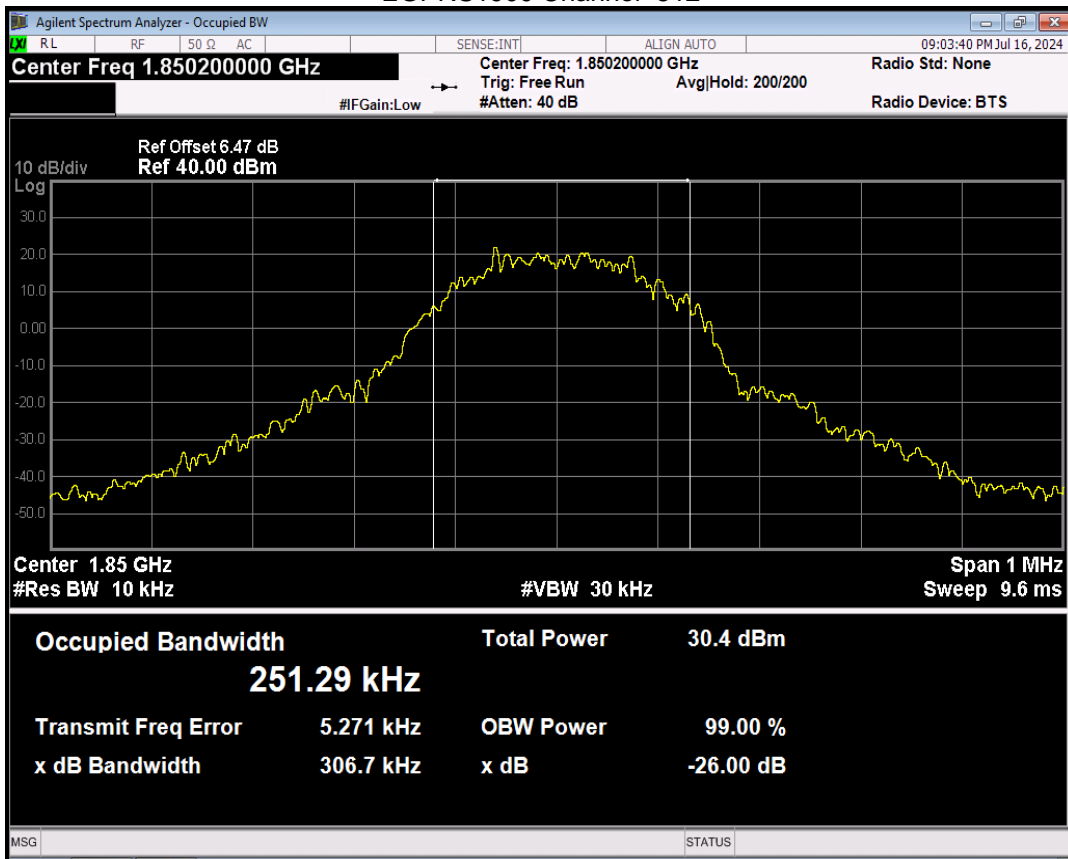

EGPRS1900 Channel=661

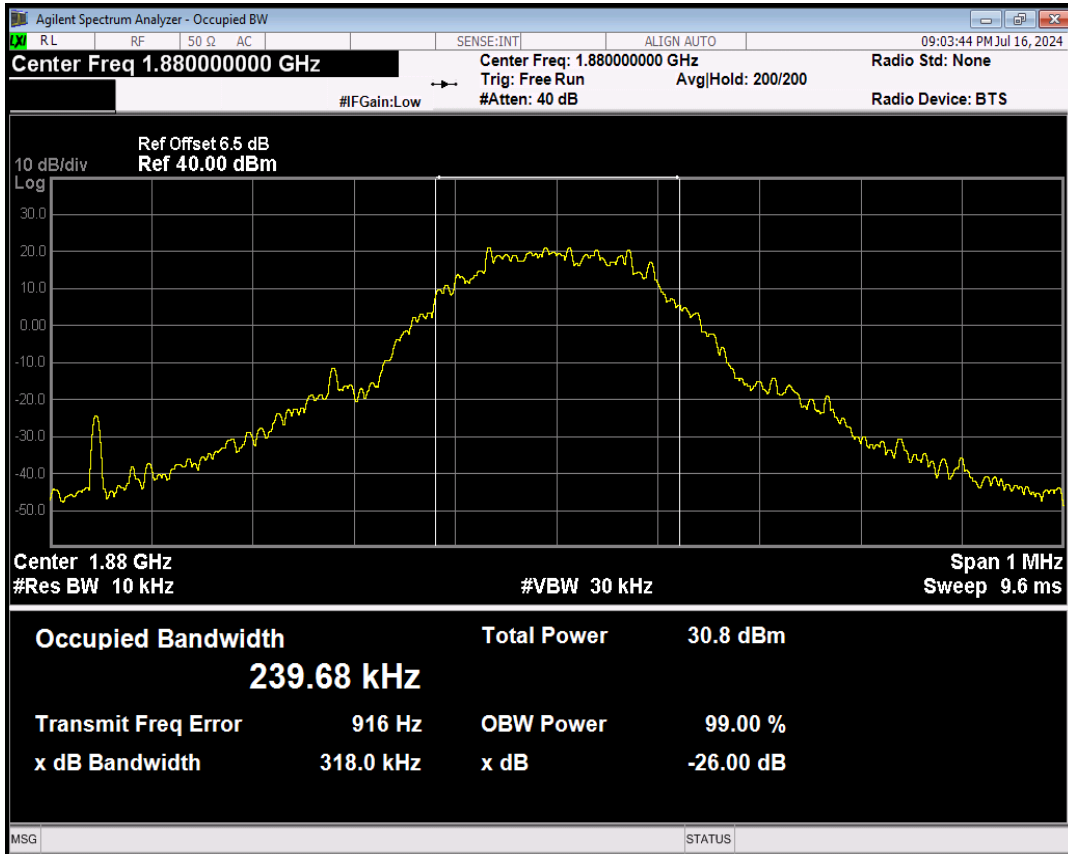

EGPRS1900 Channel=810

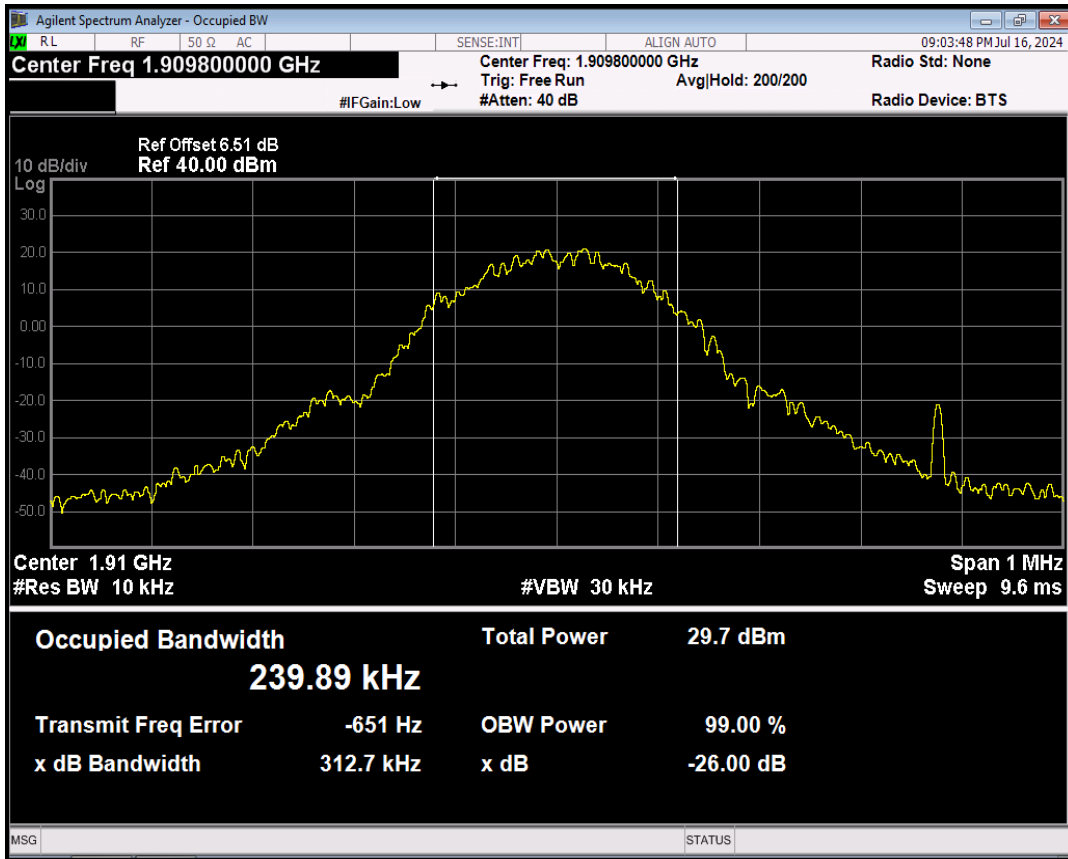

Band	Channel	Frequency (MHz)	99% OBW (kHz)	-26dB EBW (kHz)	Verdict
WCDMA Band2	9262	1852.4	4168.608	4703.657	PASS
WCDMA Band2	9400	1880	4200.519	4861.465	PASS
WCDMA Band2	9538	1907.6	4159.745	4672.837	PASS
WCDMA Band4	1312	1712.4	4167.994	4666.064	PASS
WCDMA Band4	1450	1740	4148.280	4693.342	PASS
WCDMA Band4	1513	1752.6	4157.103	4687.078	PASS
WCDMA Band5	4132	826.4	4170.109	4712.738	PASS
WCDMA Band5	4182	836.4	4144.329	4666.382	PASS
WCDMA Band5	4233	846.6	4150.545	4684.896	PASS

Note: In WCDMA, RMC, HSDPA and HSUPA all three tests only reflect the worst mode RMC.

WCDMA Band2 Channel=9262

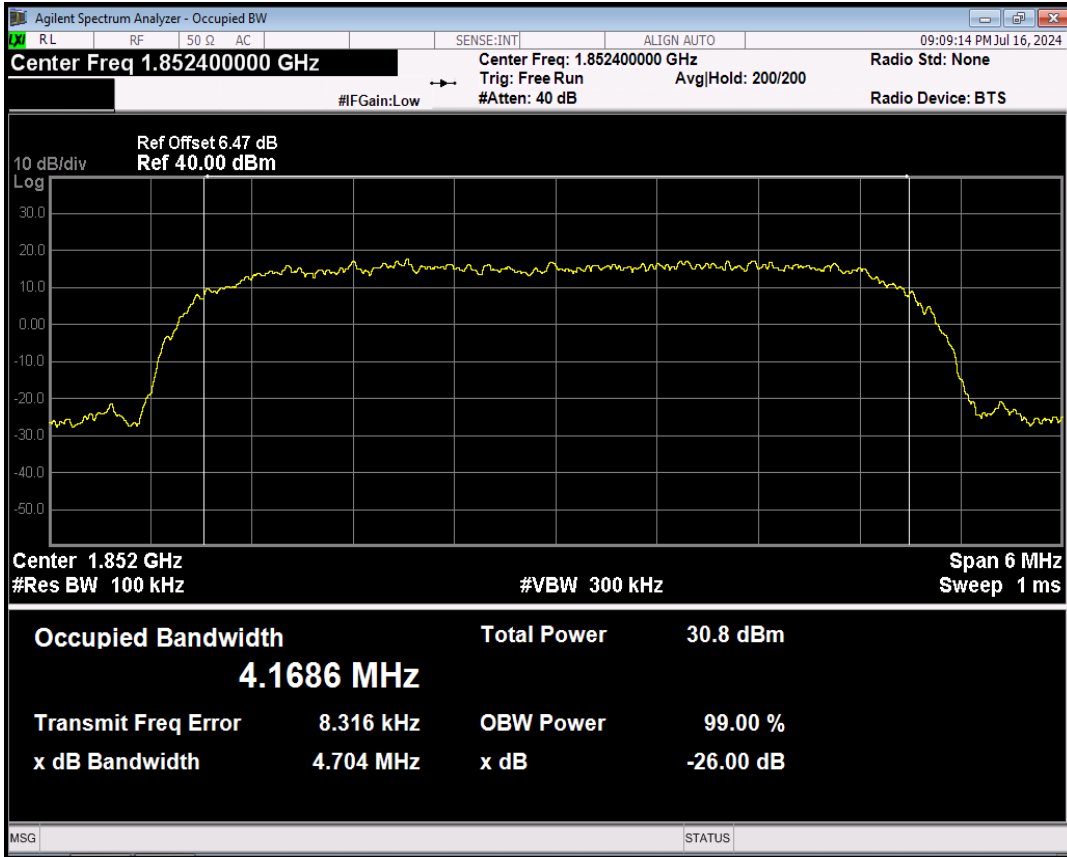

WCDMA Band2 Channel=9400

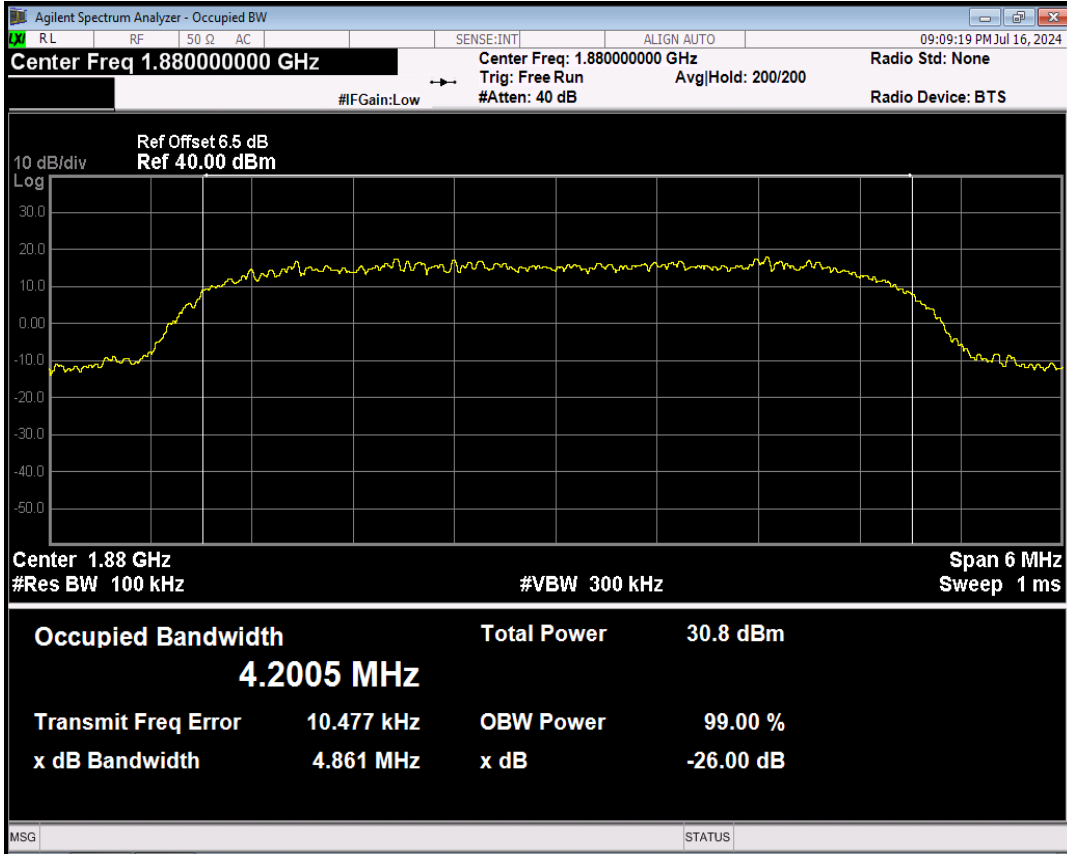

WCDMA Band2 Channel=9538

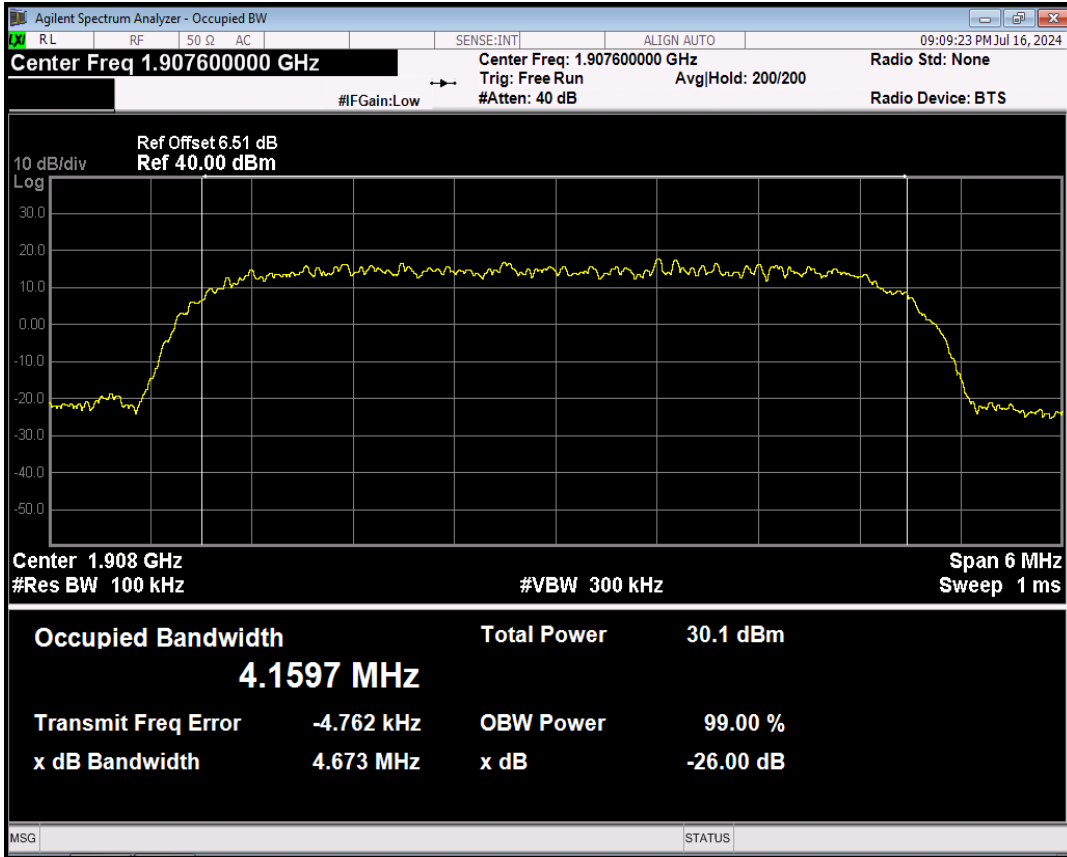

WCDMA Band4 Channel=1312

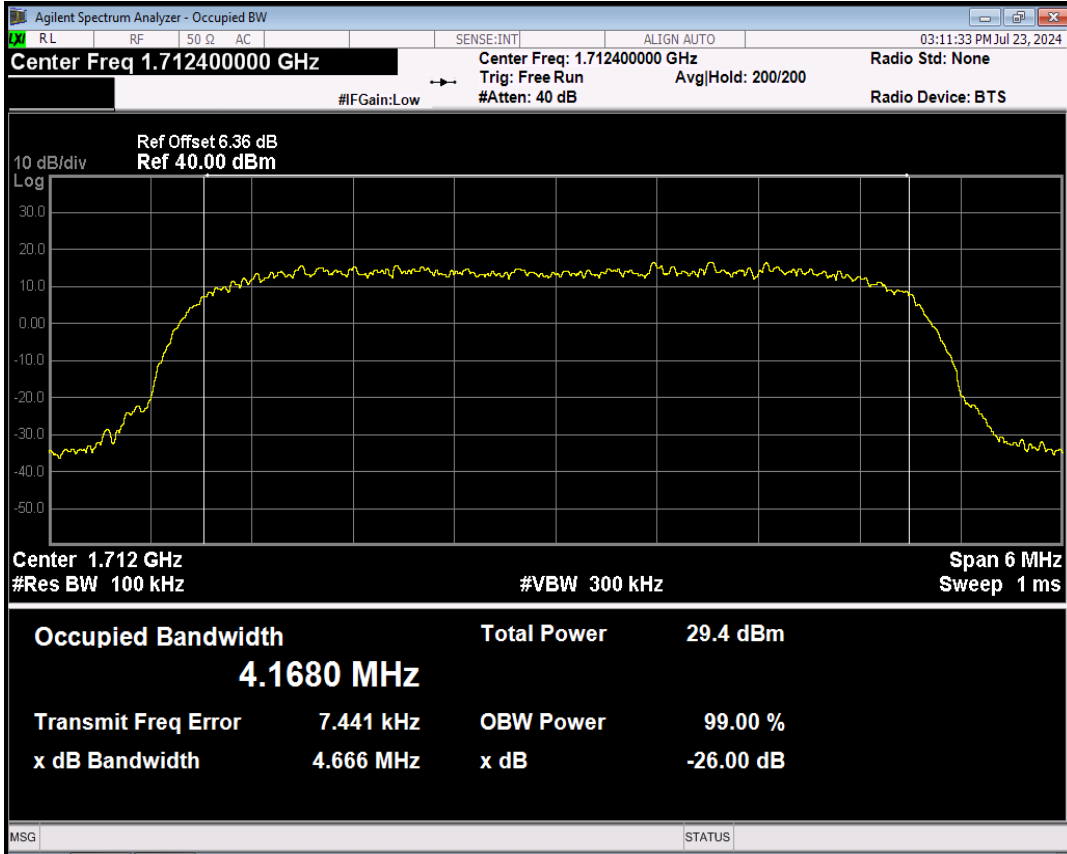

WCDMA Band4 Channel=1450

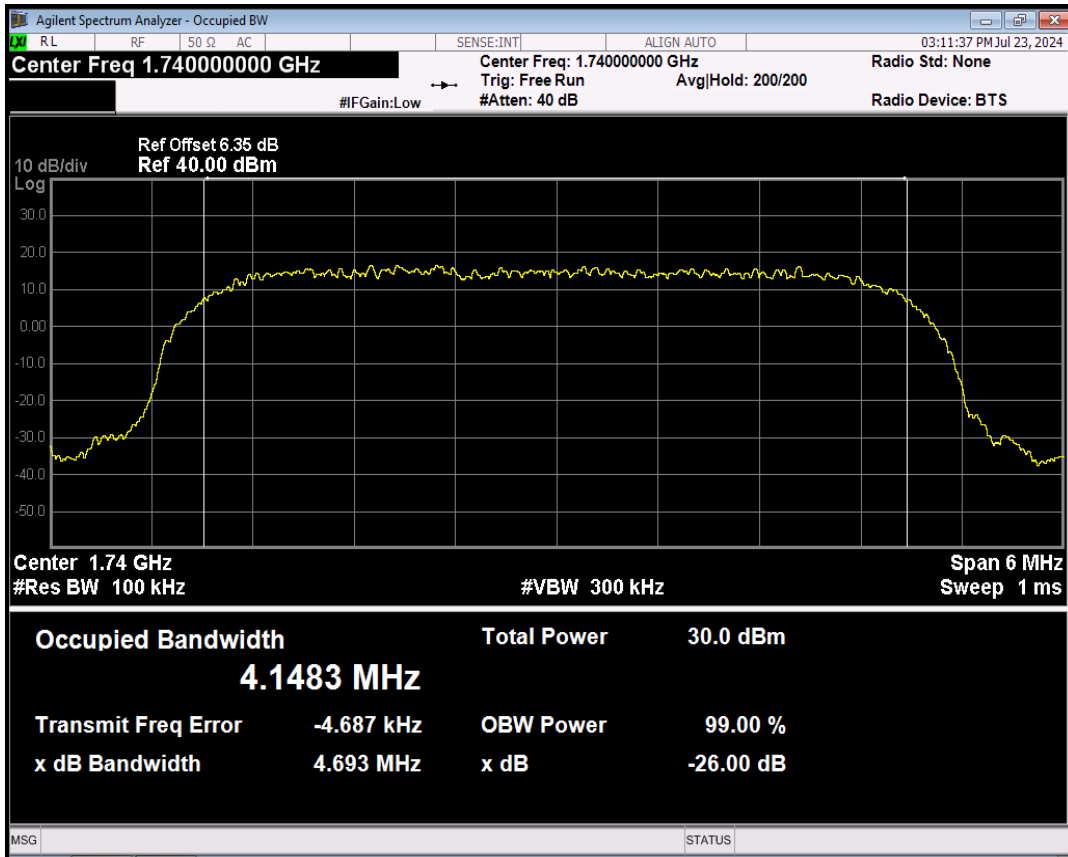

WCDMA Band4 Channel=1513

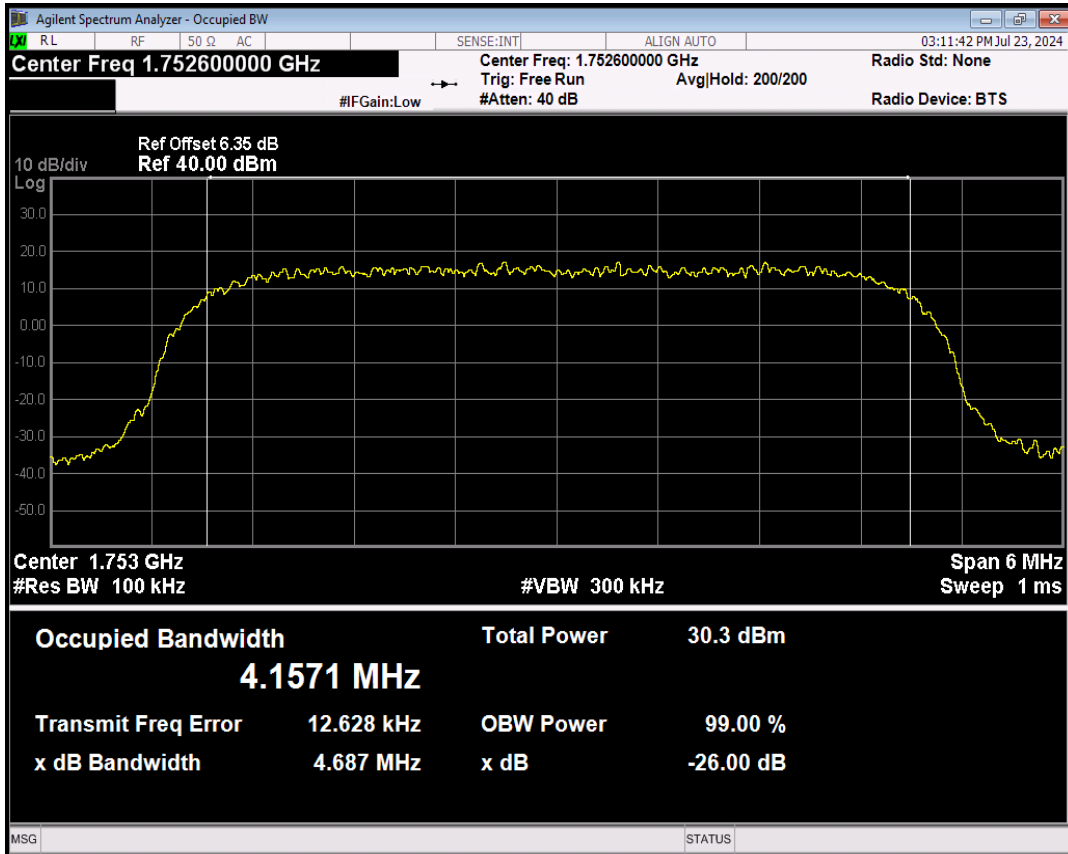

WCDMA Band5 Channel=4132

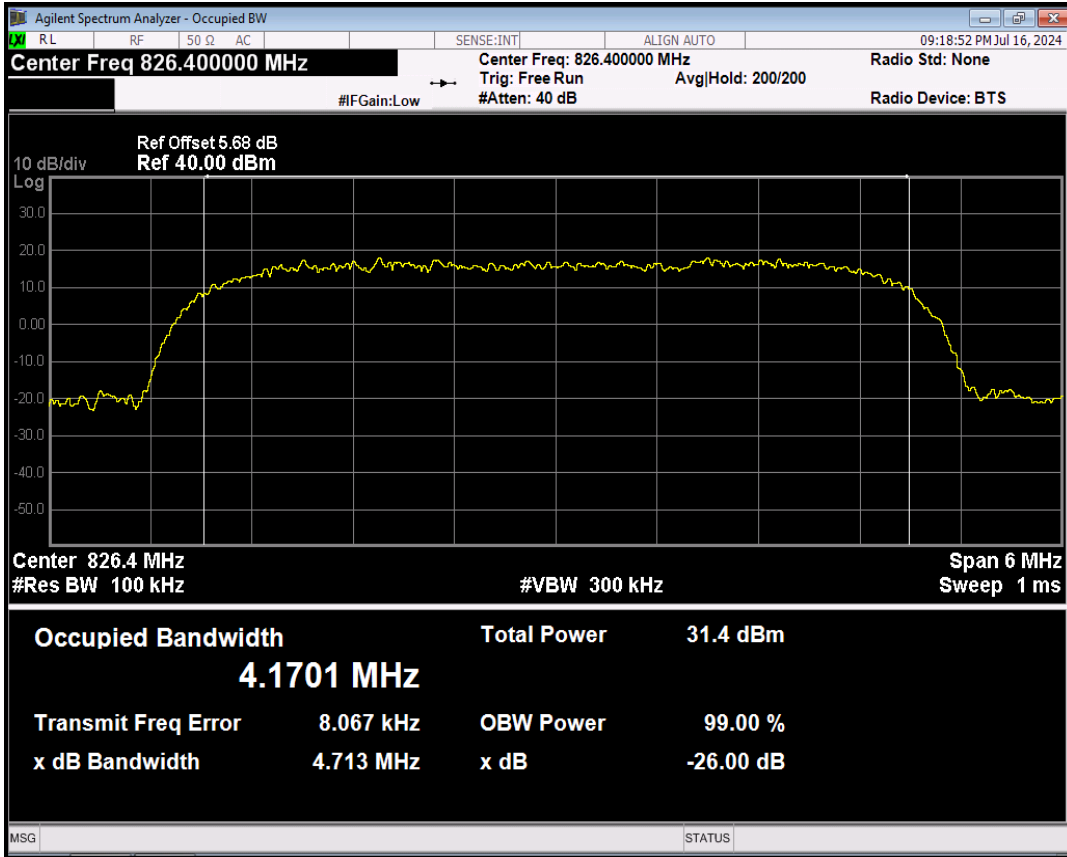

WCDMA Band5 Channel=4182

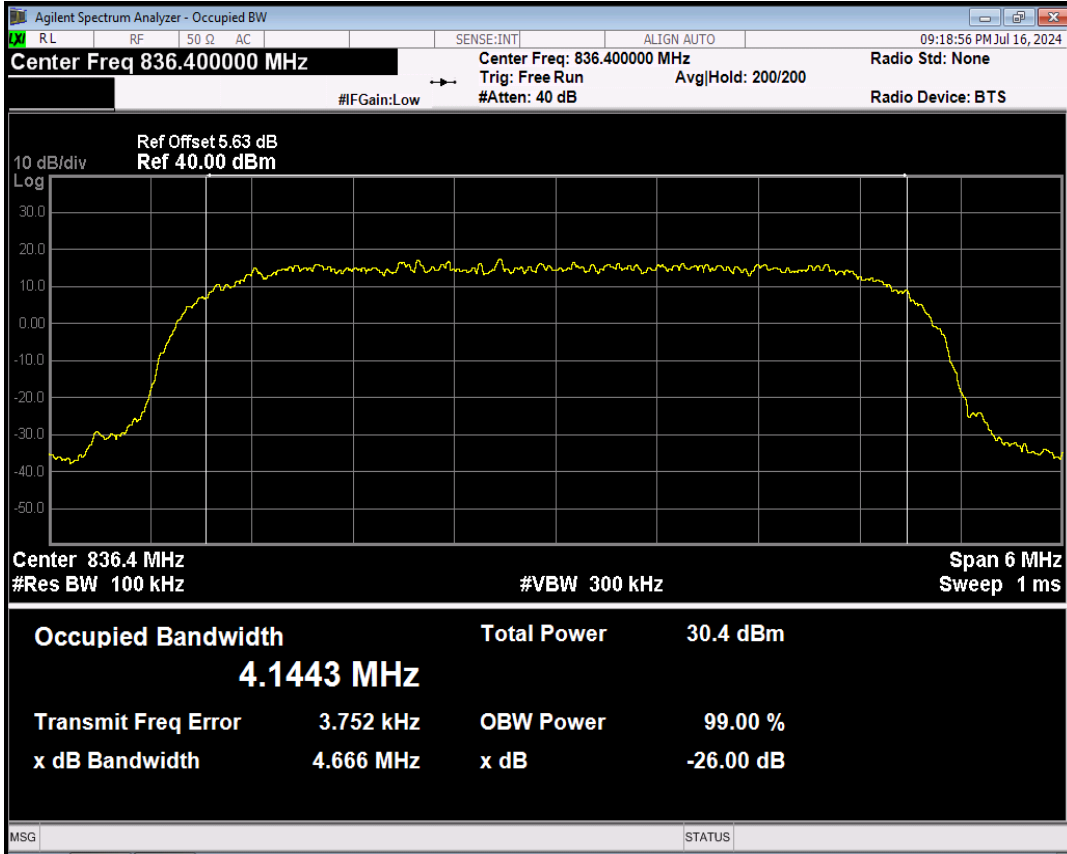

WCDMA Band5 Channel=4233

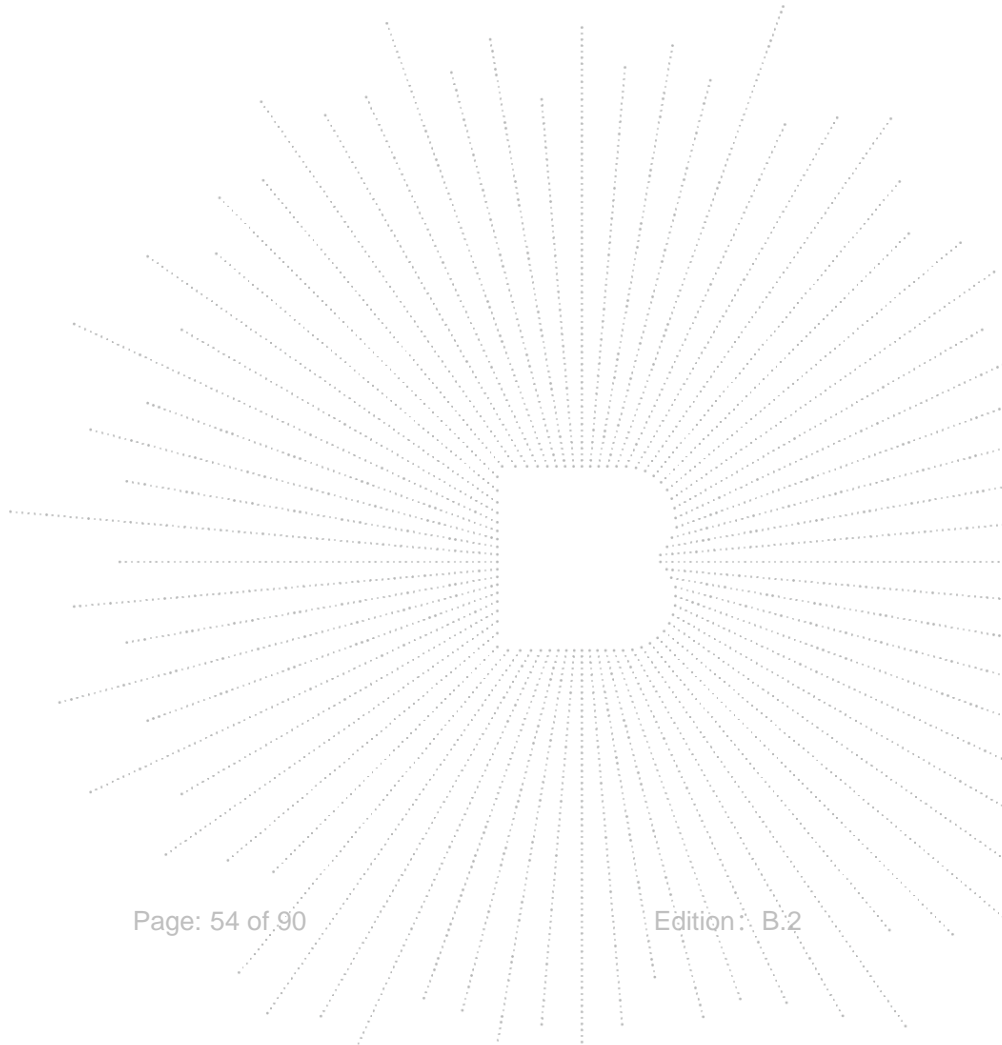
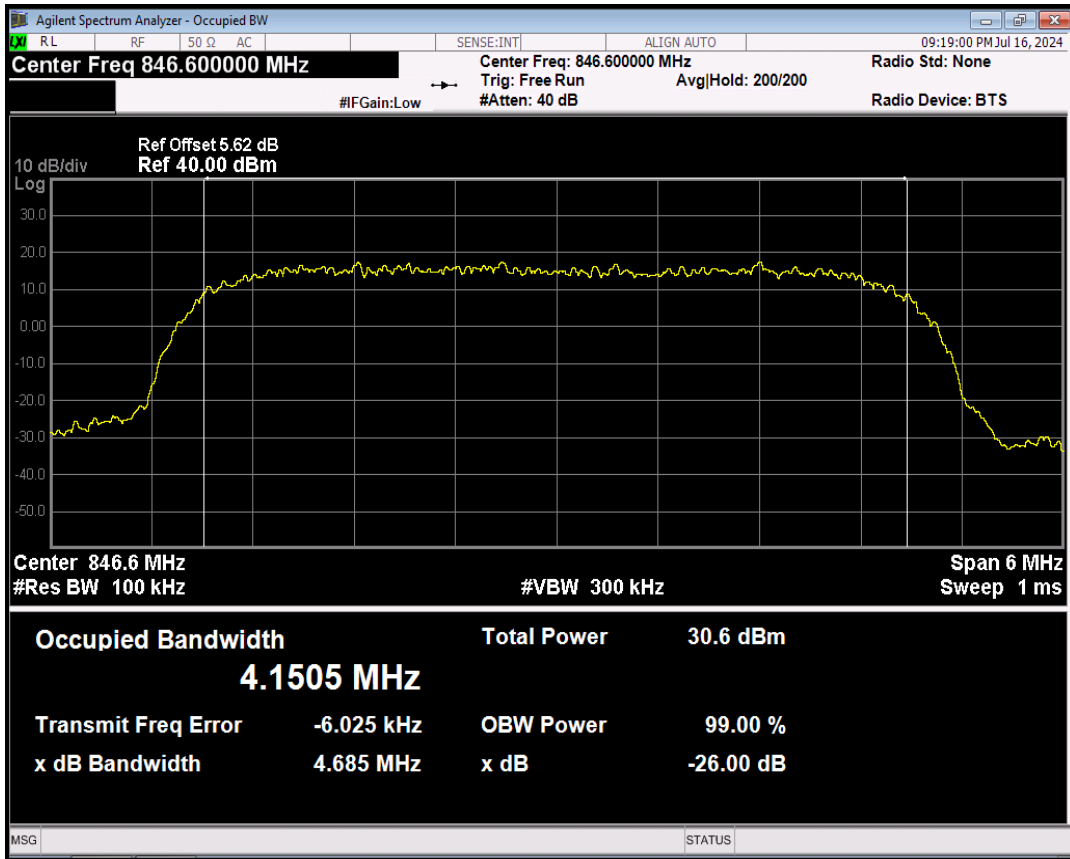

9. Out of Band Emissions at Antenna Terminal

9.1 Block Diagram Of Test Setup

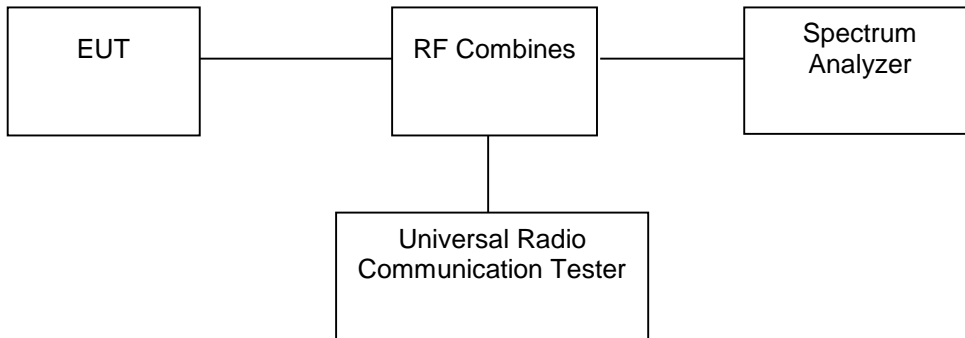

9.2 Limit

According to §22.917(a), the power of any emissions outside of the authorized operating frequency ranges must be attenuated below the transmitting power (P) by a factor of at least $43 + 10 \log(P)$ dB.

According to §24.238(a), the power of any emissions outside of the authorized operating frequency ranges must be attenuated below the transmitting power (P) by a factor of at least $43 + 10 \log(P)$ dB.

According to §27.53 (h), the power of any emission outside a licensee's frequency block shall be attenuated below the transmitter power (P) in watts by at least $43 + 10 \log_{10}(P)$ dB.

9.3 Test procedure

The RF output terminal of the transmitter was connected to the input of the spectrum analyzer via a suitable attenuation. The RBW of the spectrum analyzer was set to 100kHz and 1MHz for the scan frequency from 30MHz to 1GHz and the scan frequency from 1GHz to up to 10th harmonic. At the edge of the authorized Frequency block/band: RBW set 1%-5%OBW.

9.4 Test Result

GSM1900 Channel=512

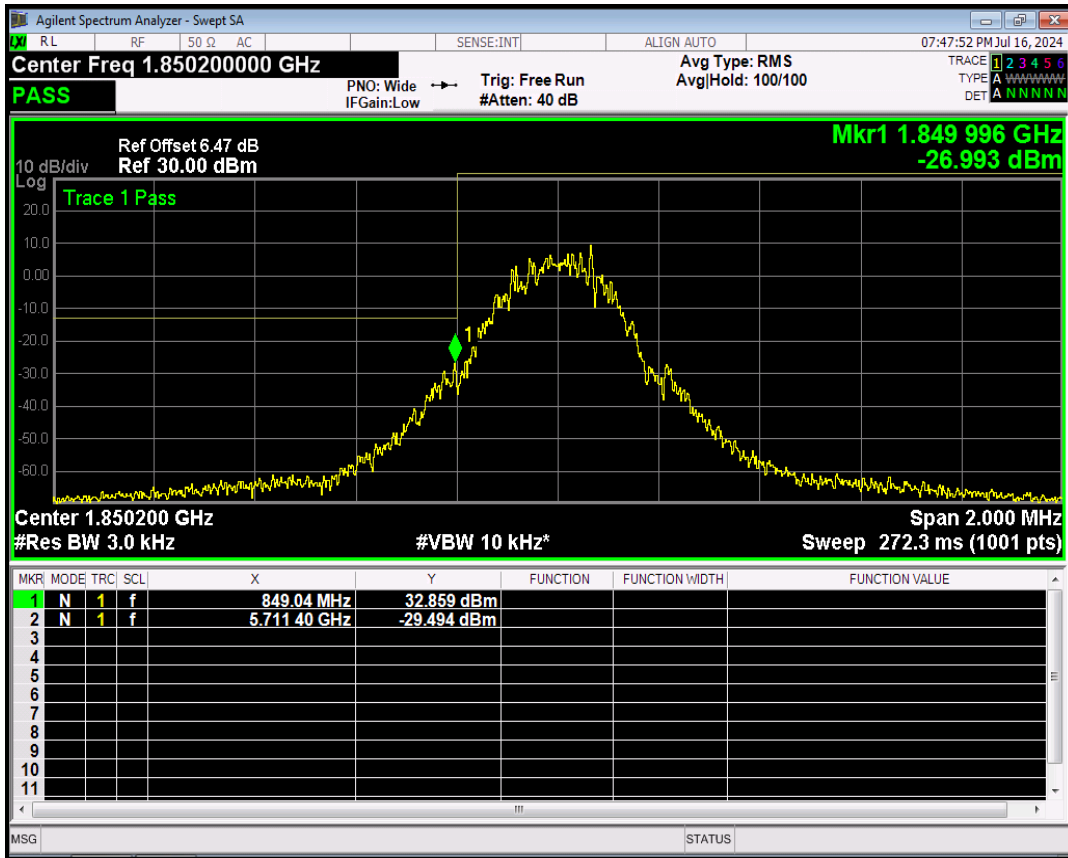

GSM1900 Channel=810

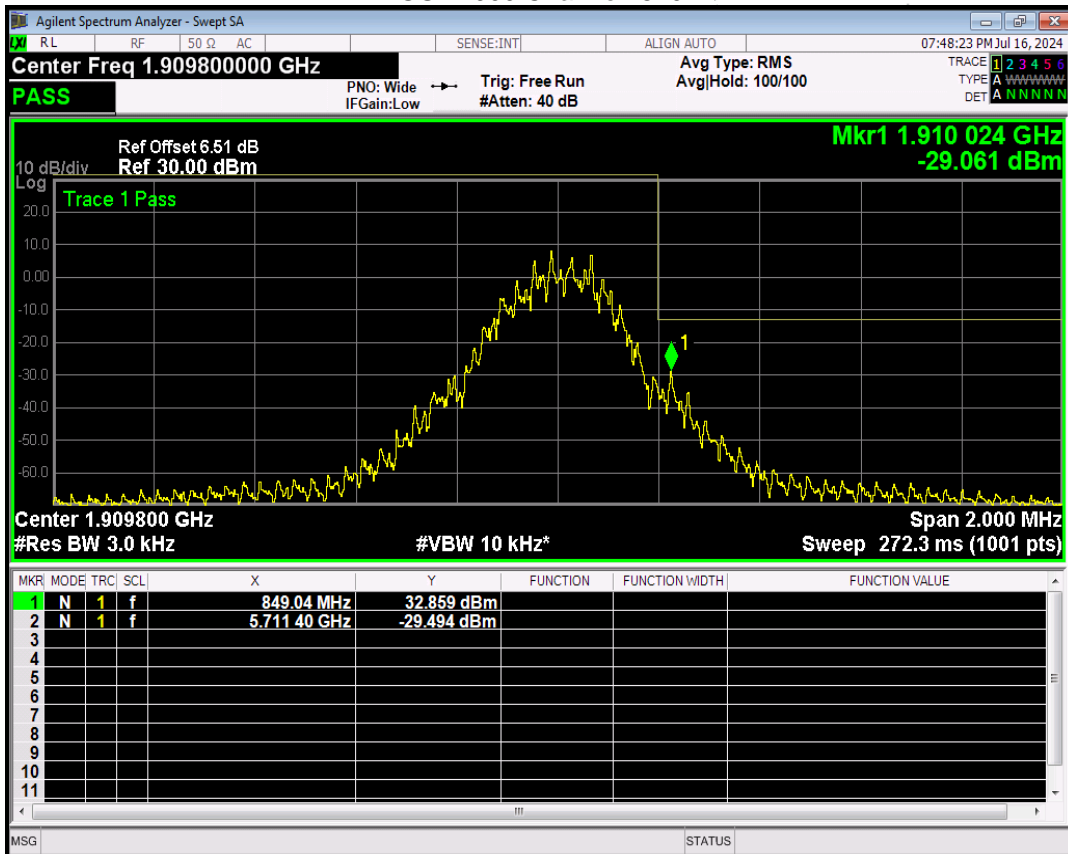

GSM850 Channel=128

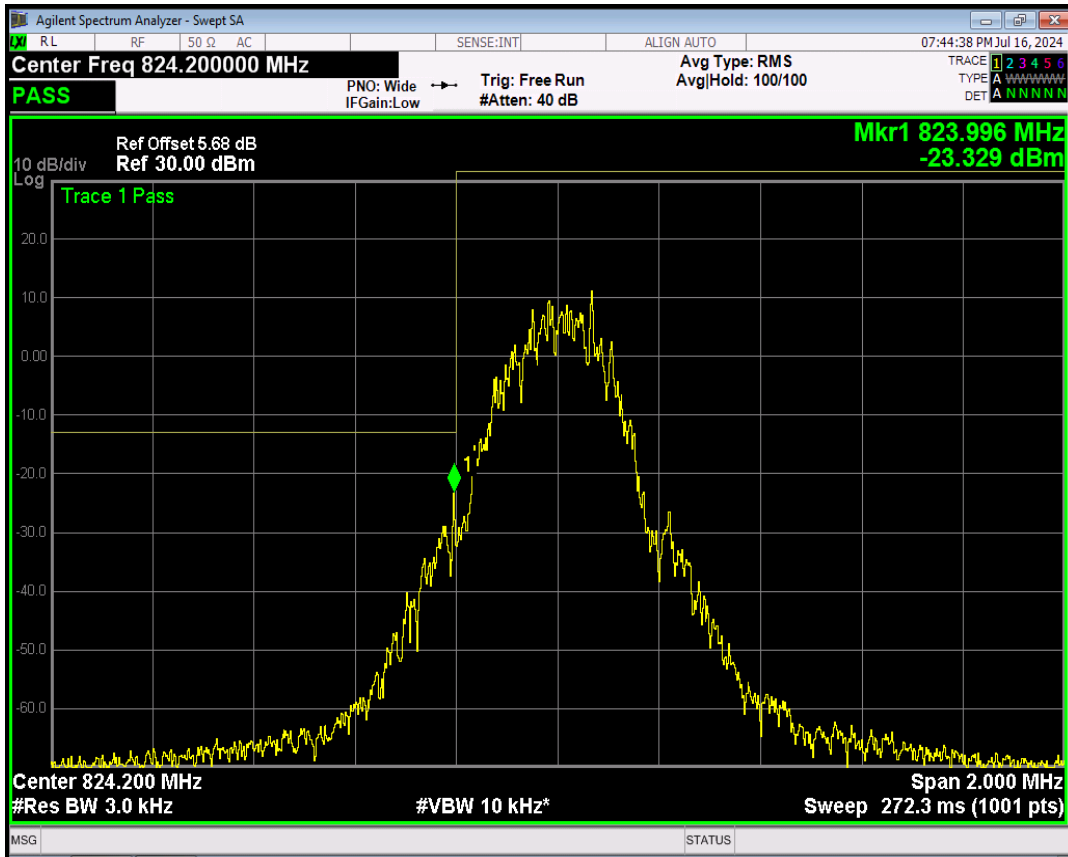

GSM850 Channel=251

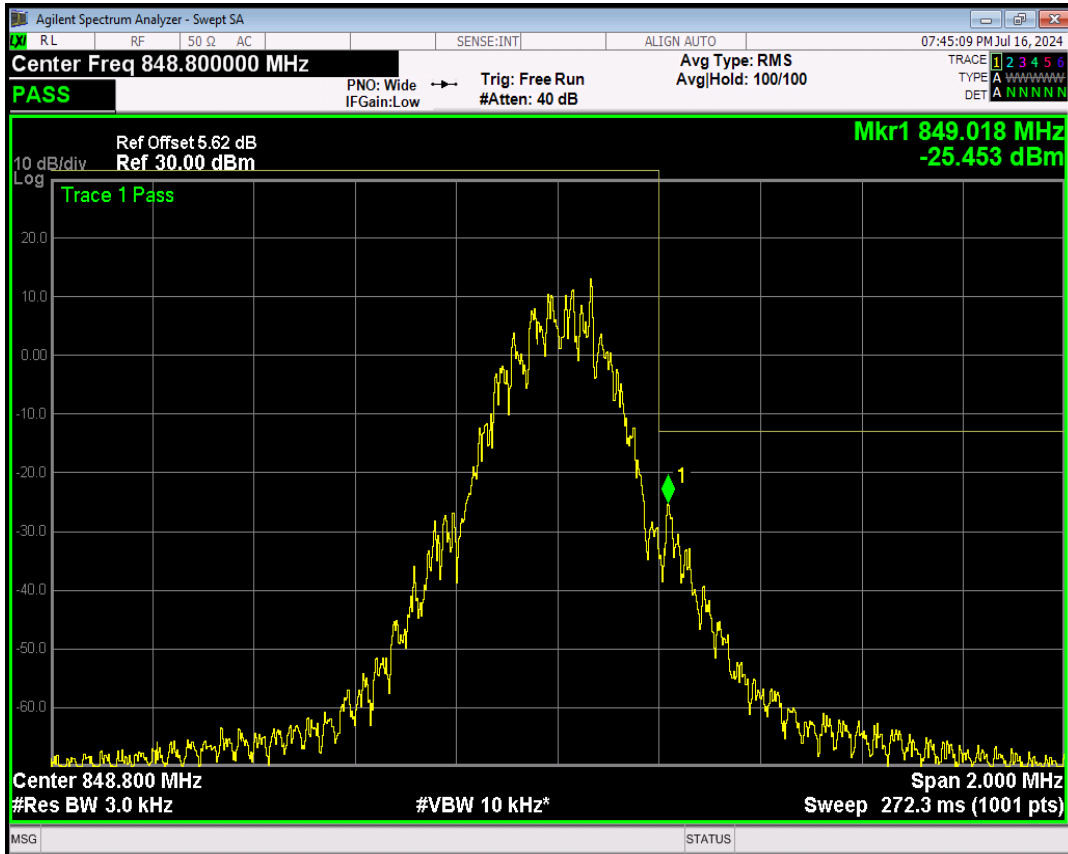

GSM1900 Channel=512

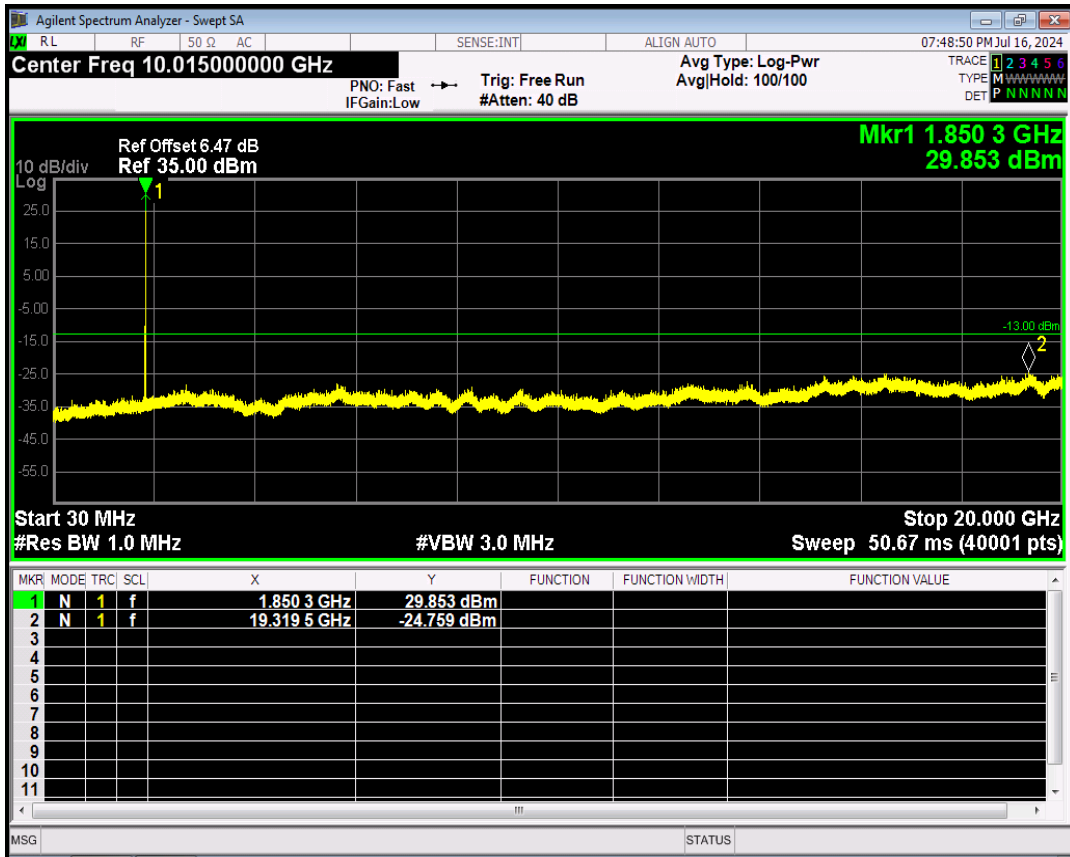

GSM1900 Channel=661

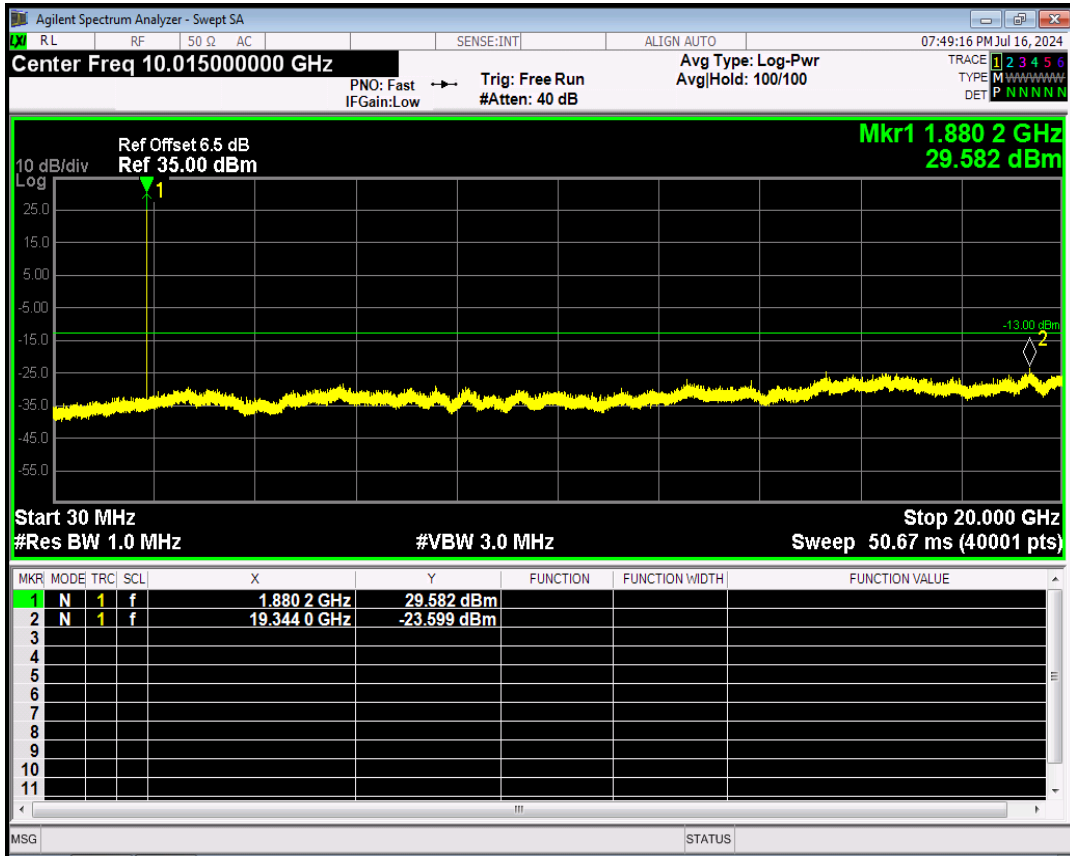

GSM1900 Channel=810

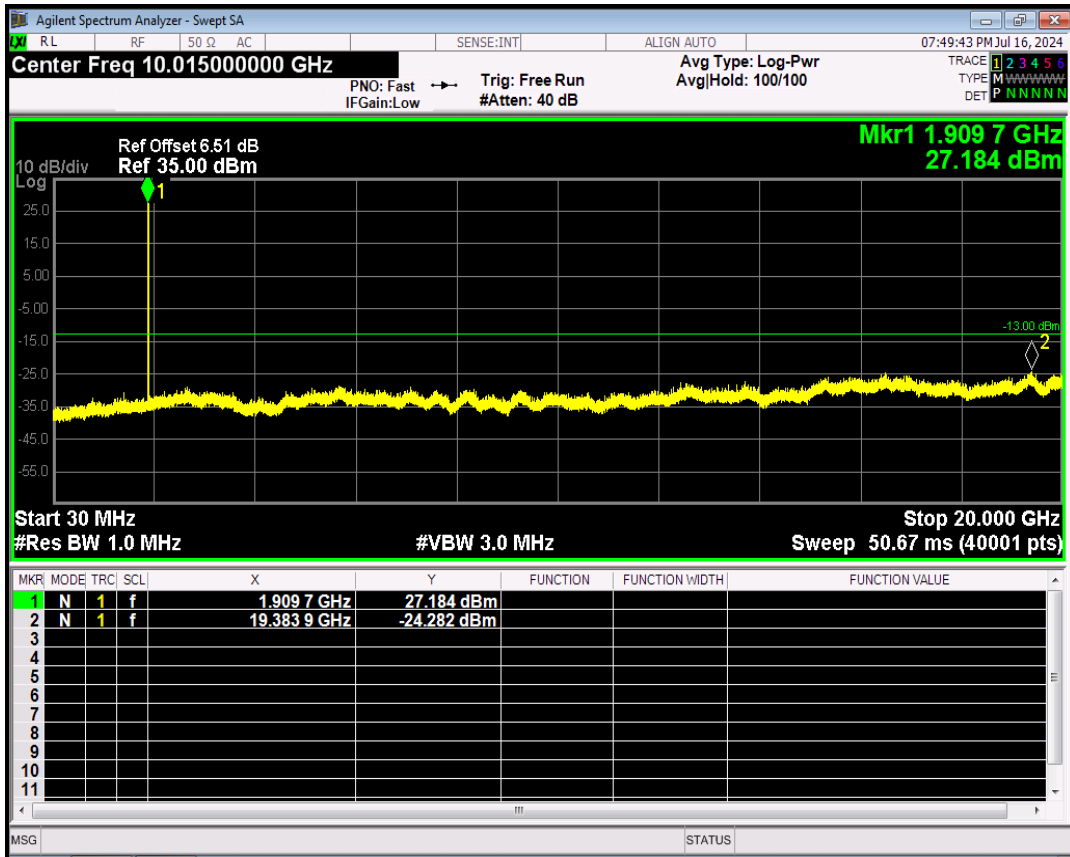

GSM850 Channel=128

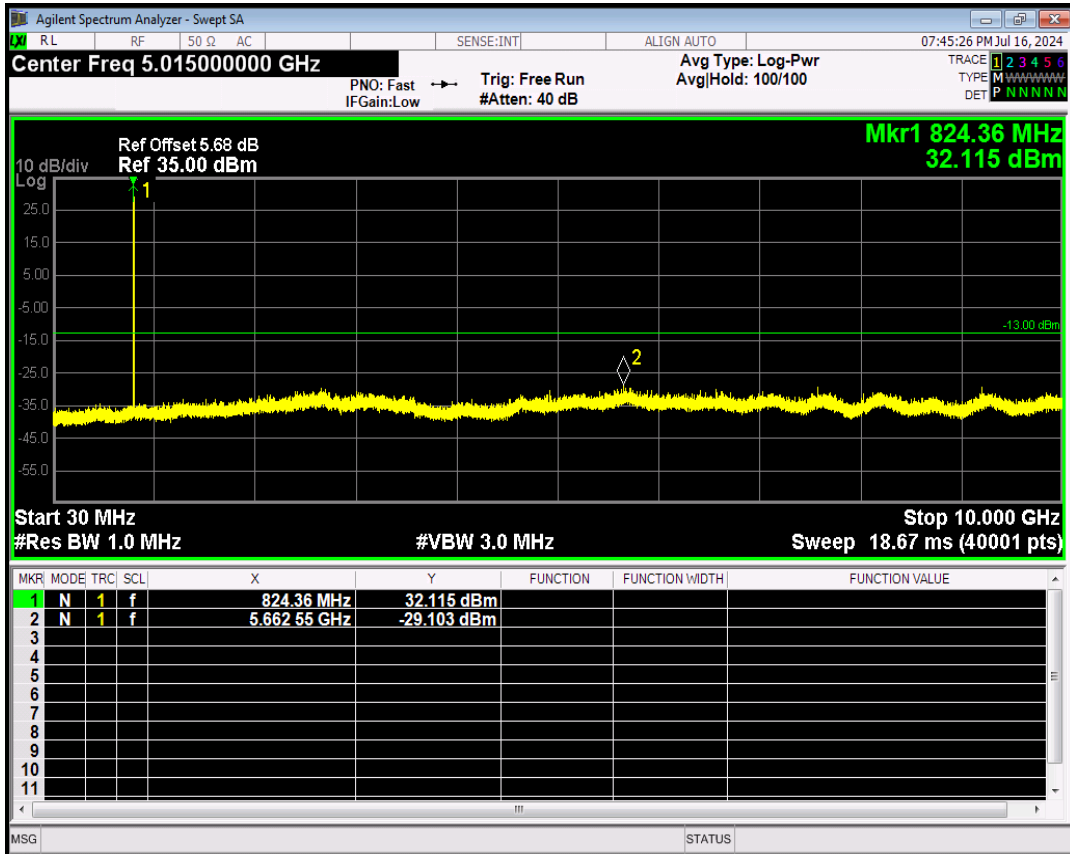

GSM850 Channel=190

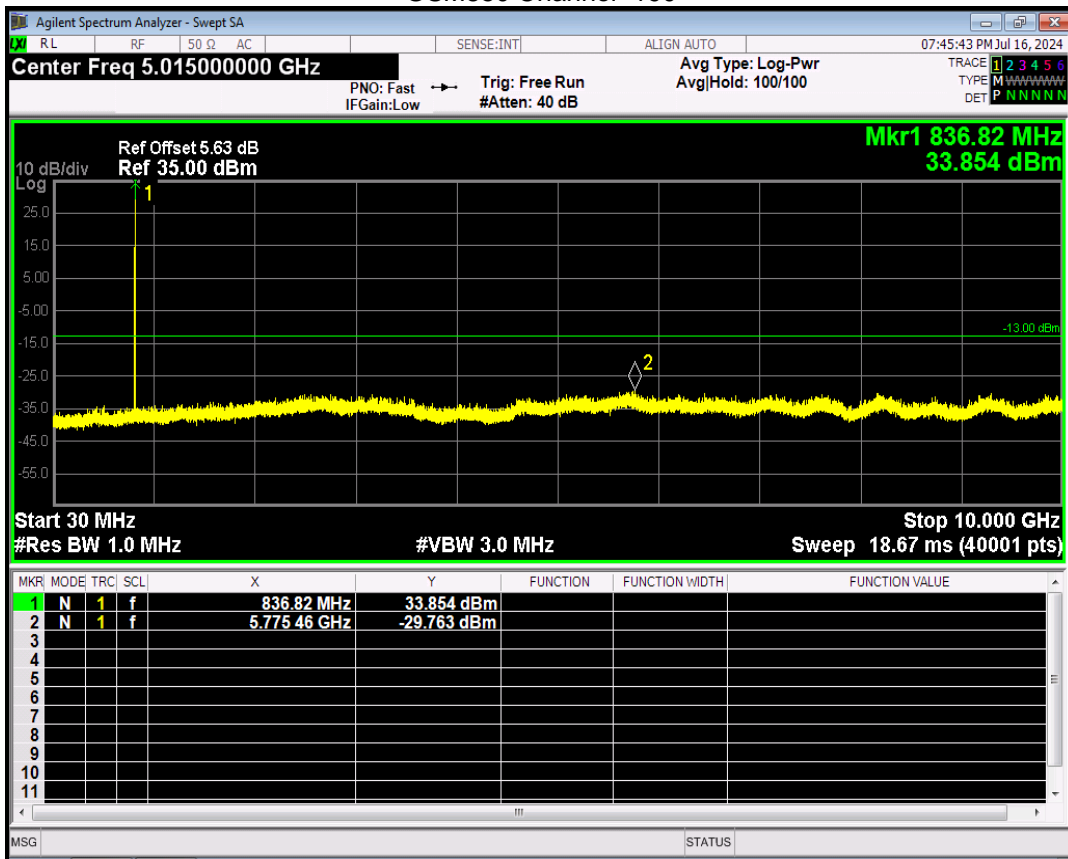

GSM850 Channel=251

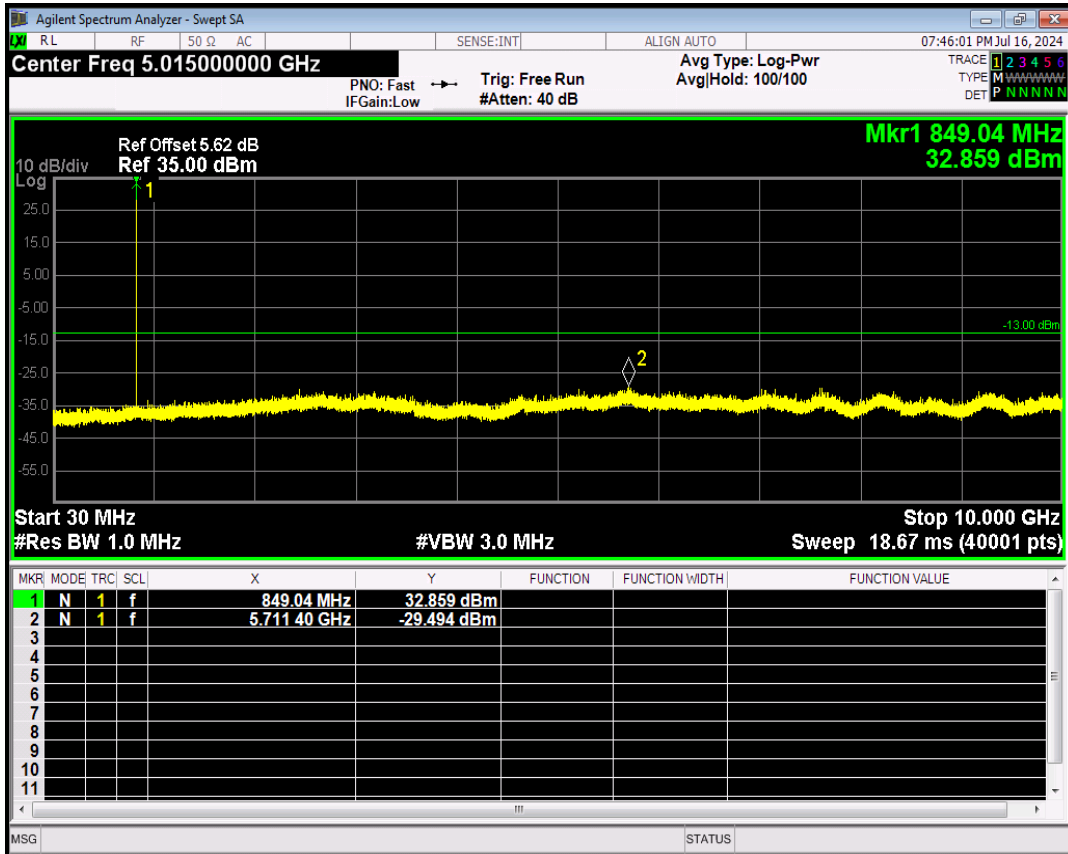

GPRS1900 Channel=512

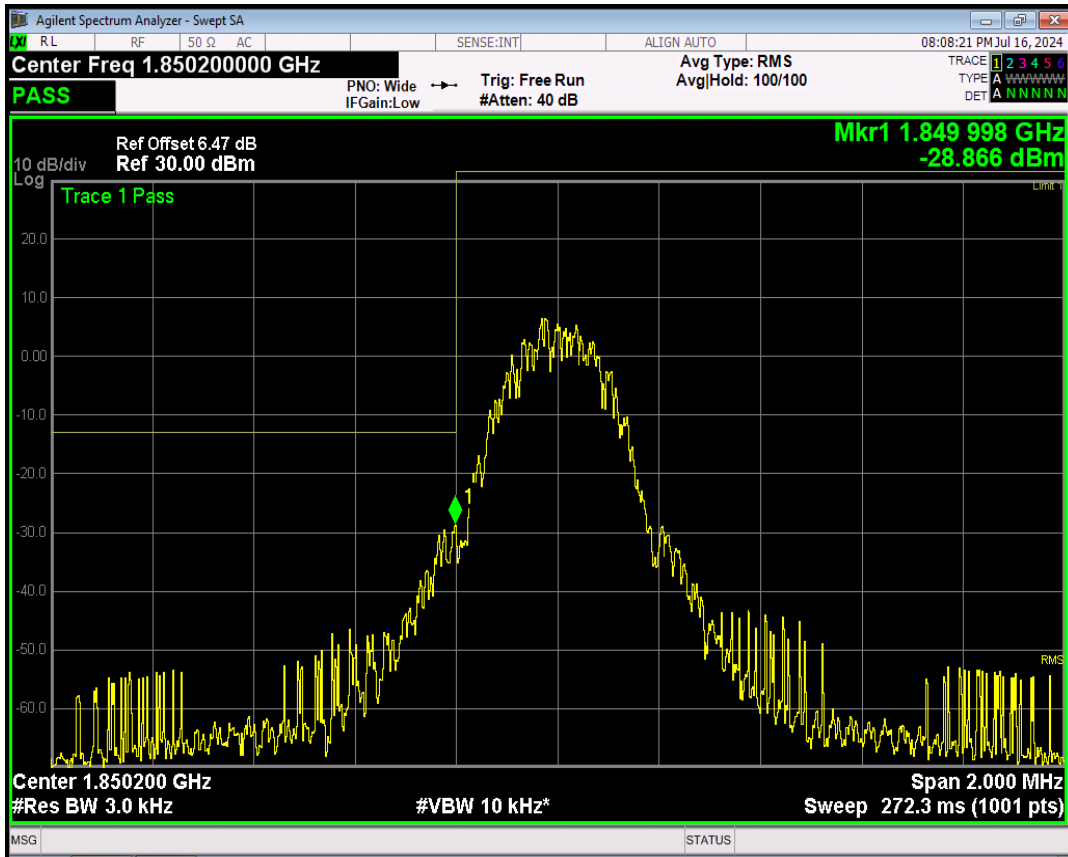

GPRS1900 Channel=810

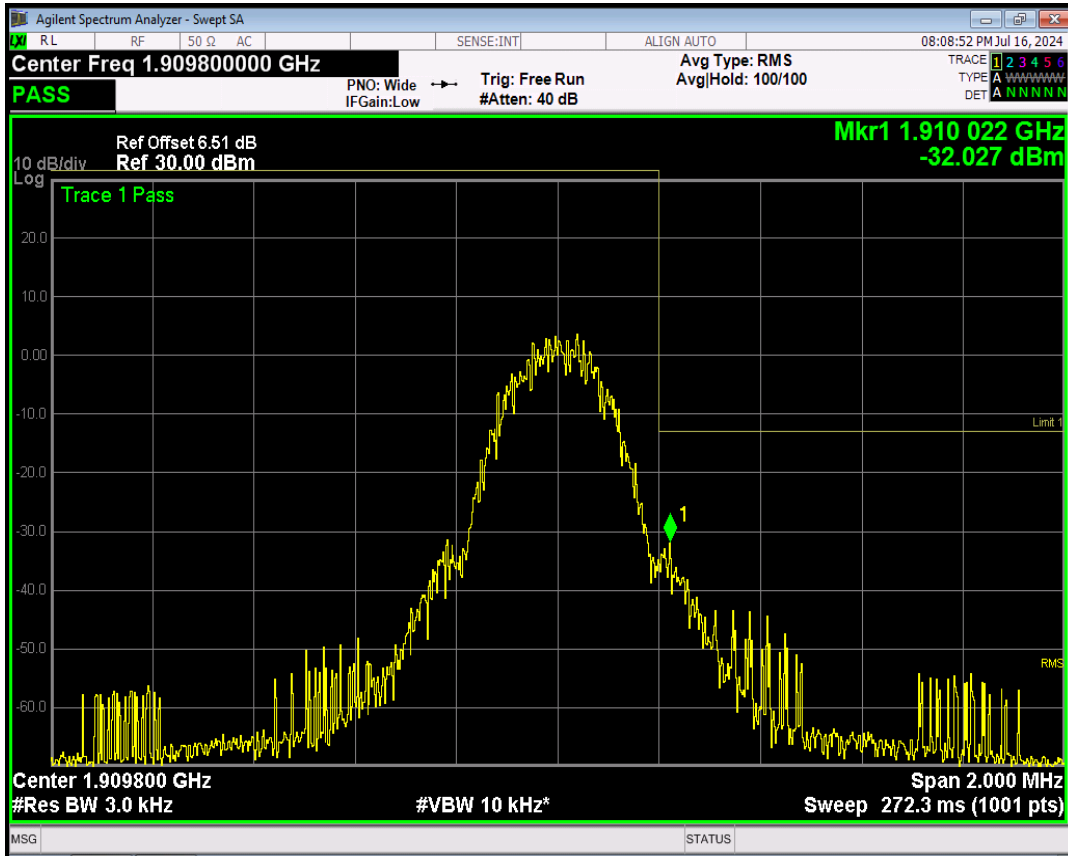

GPRS850 Channel=128

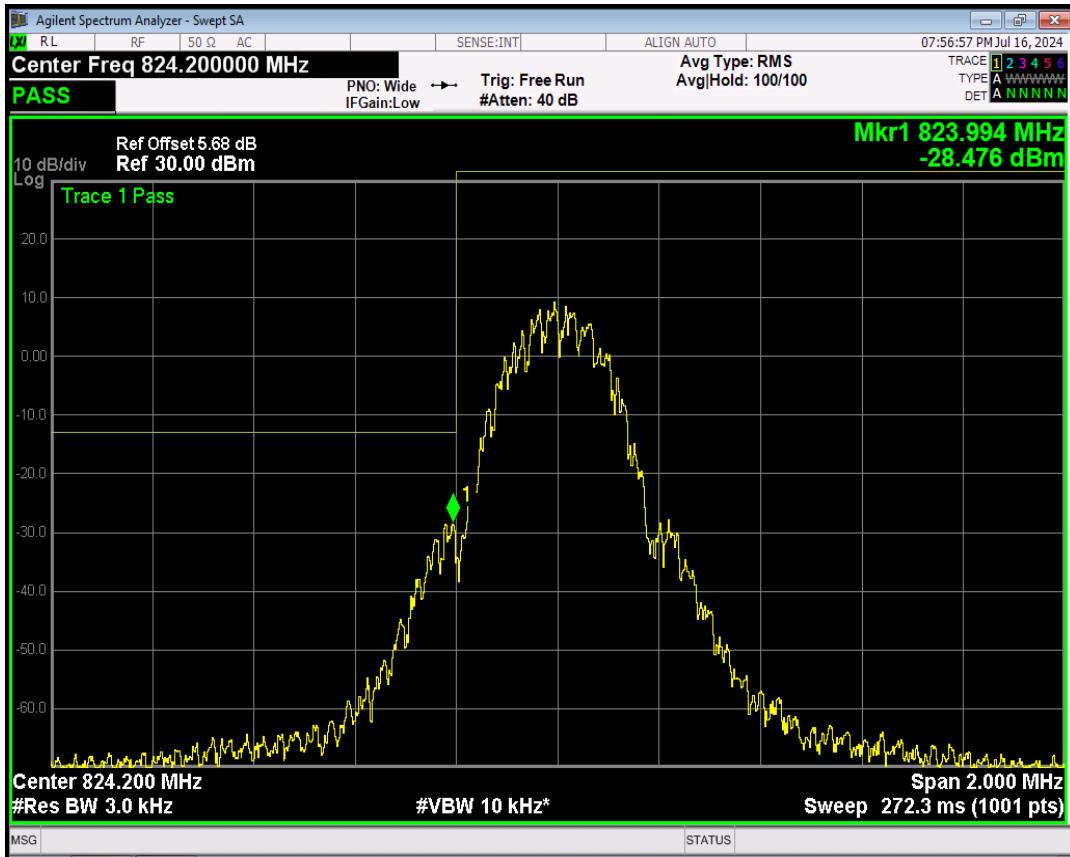

GPRS850 Channel=251

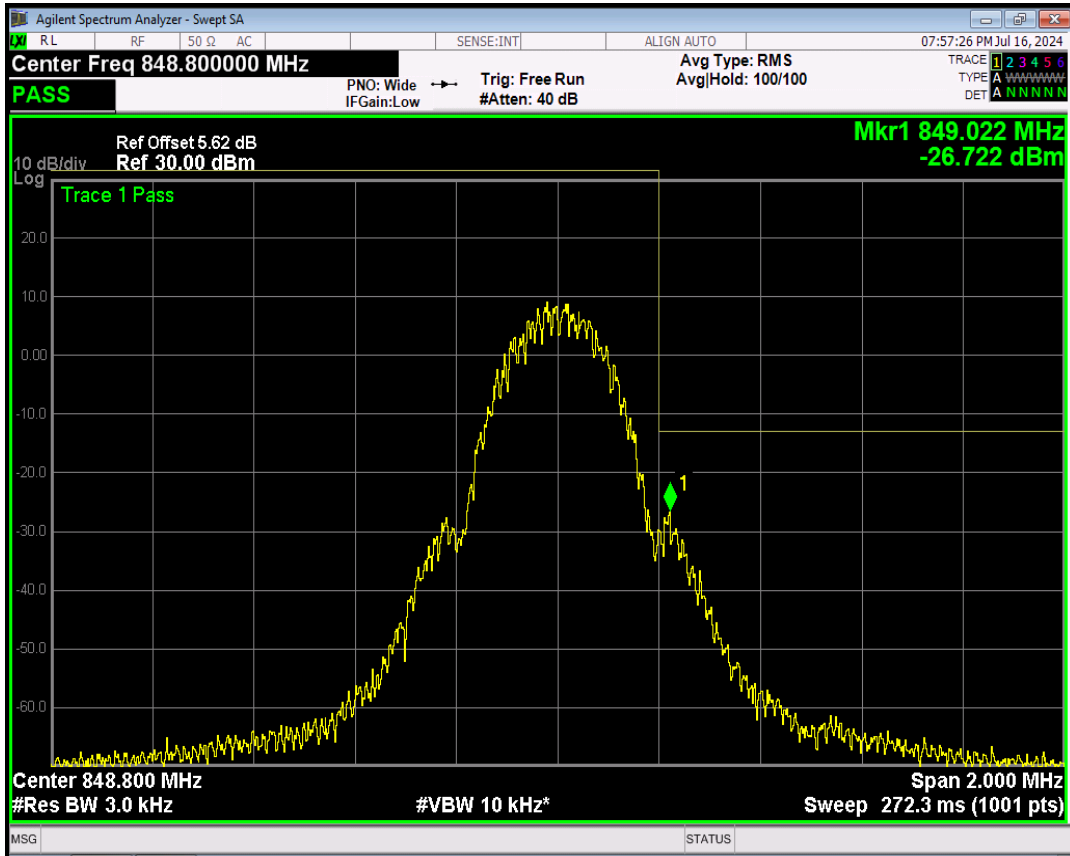

GPRS1900 Channel=512

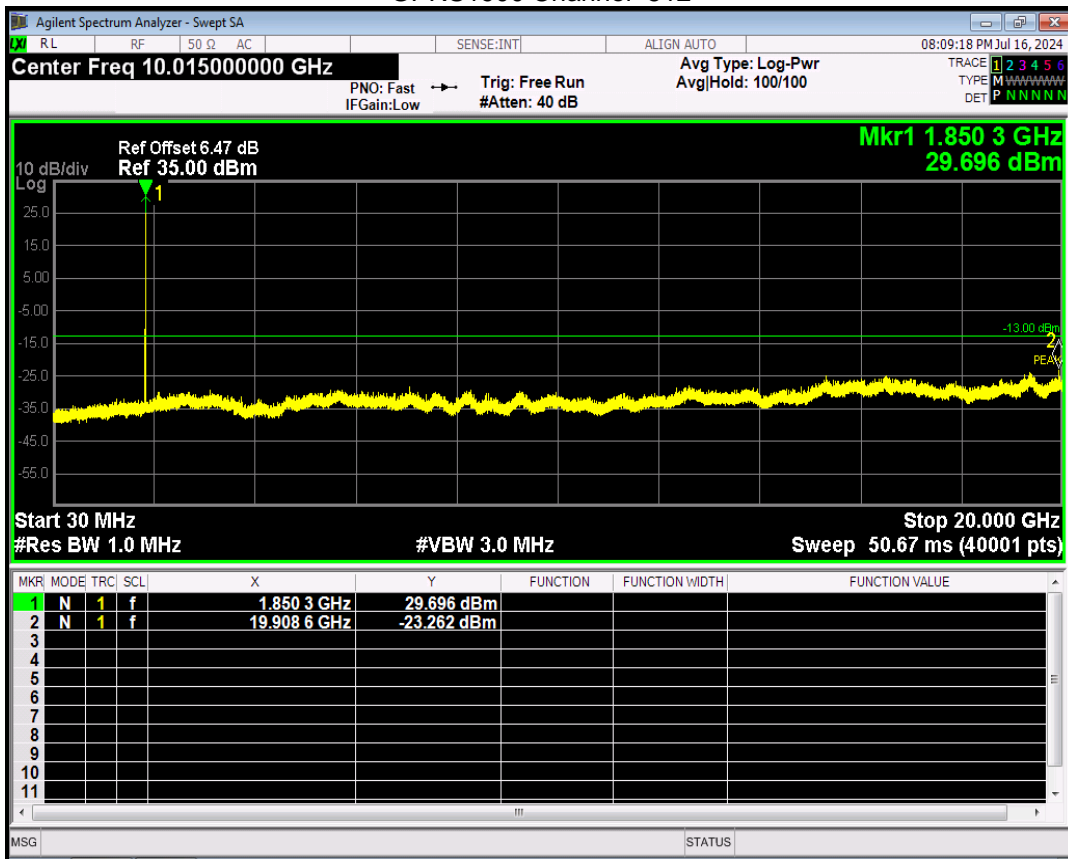

GPRS1900 Channel=661

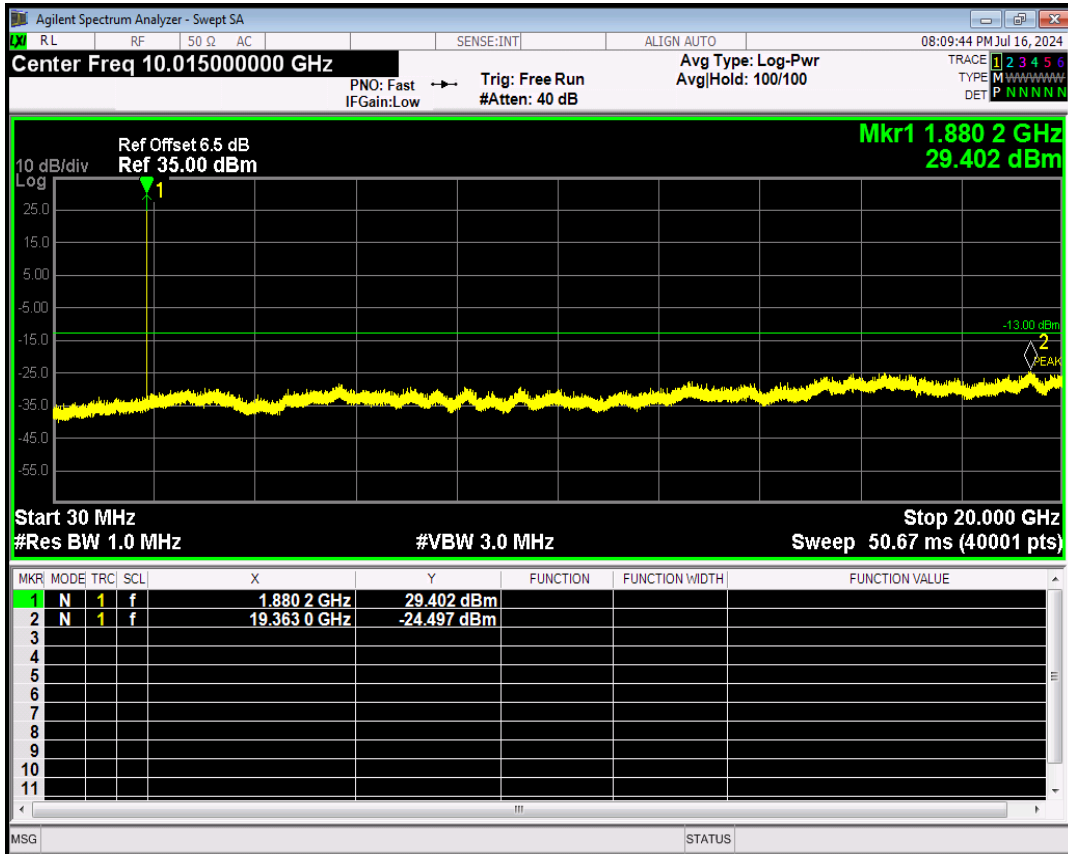

GPRS1900 Channel=810

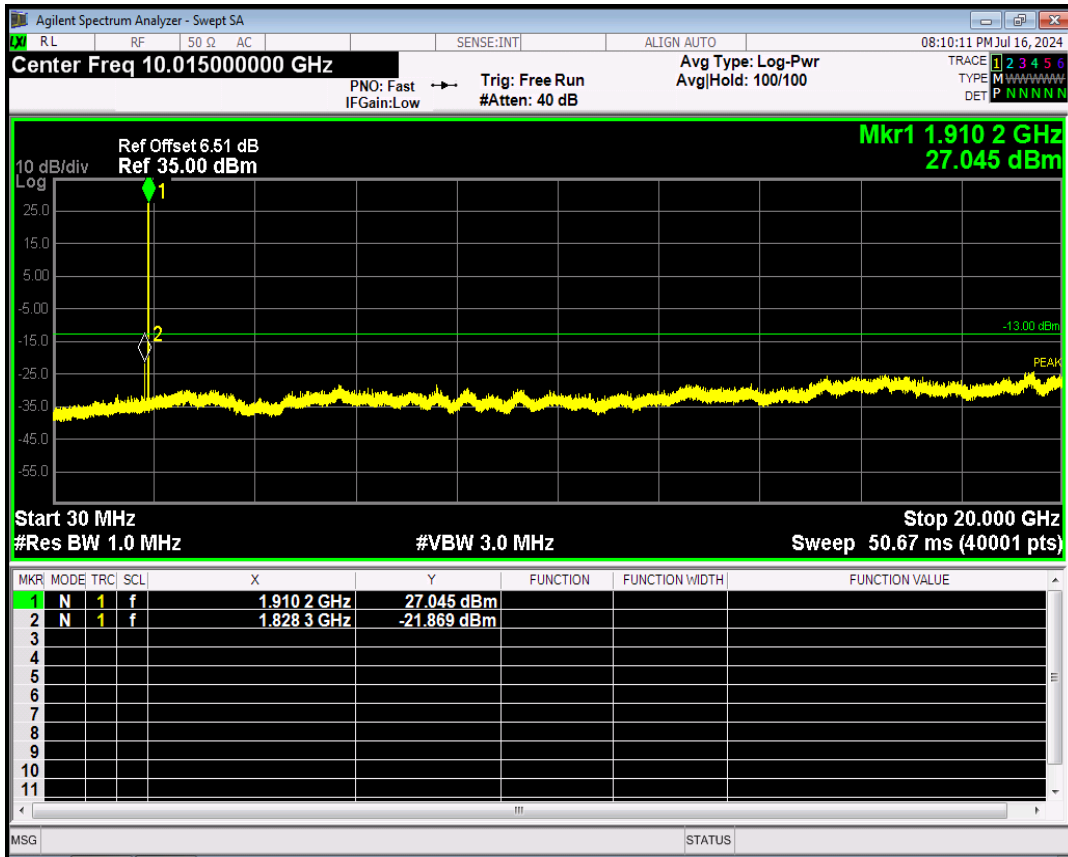

GPRS850 Channel=128

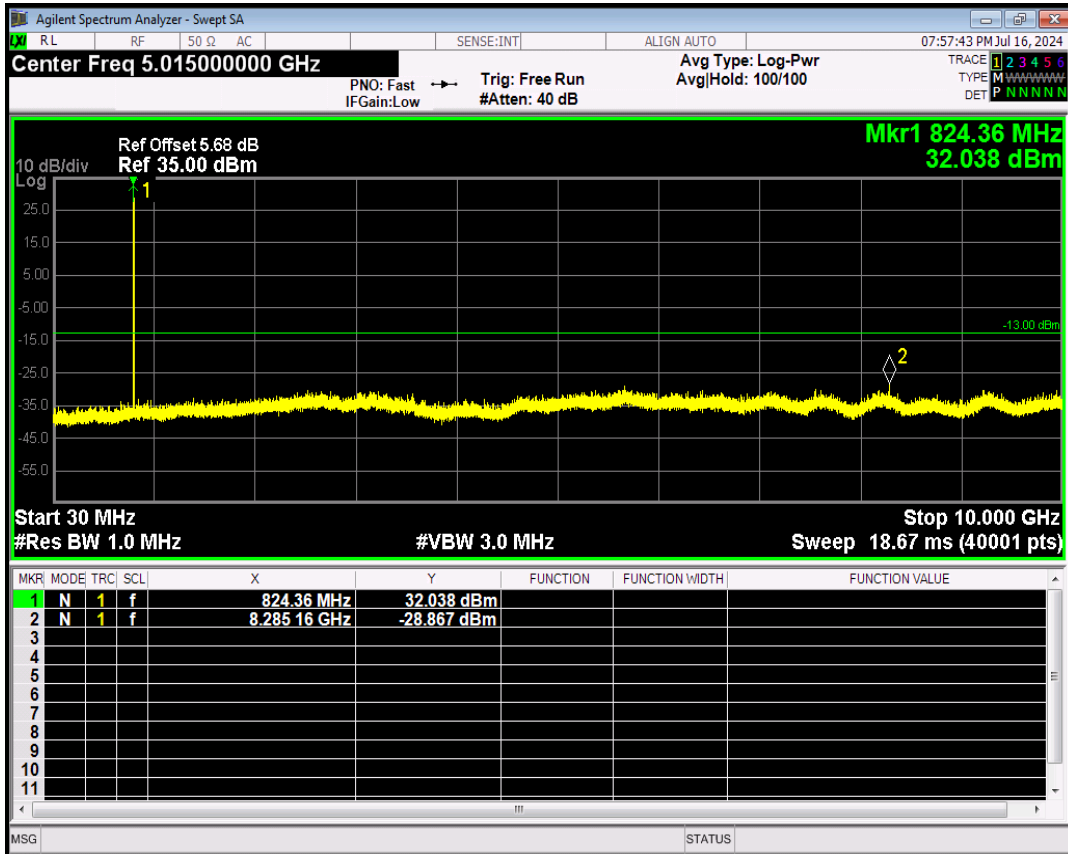

GPRS850 Channel=190

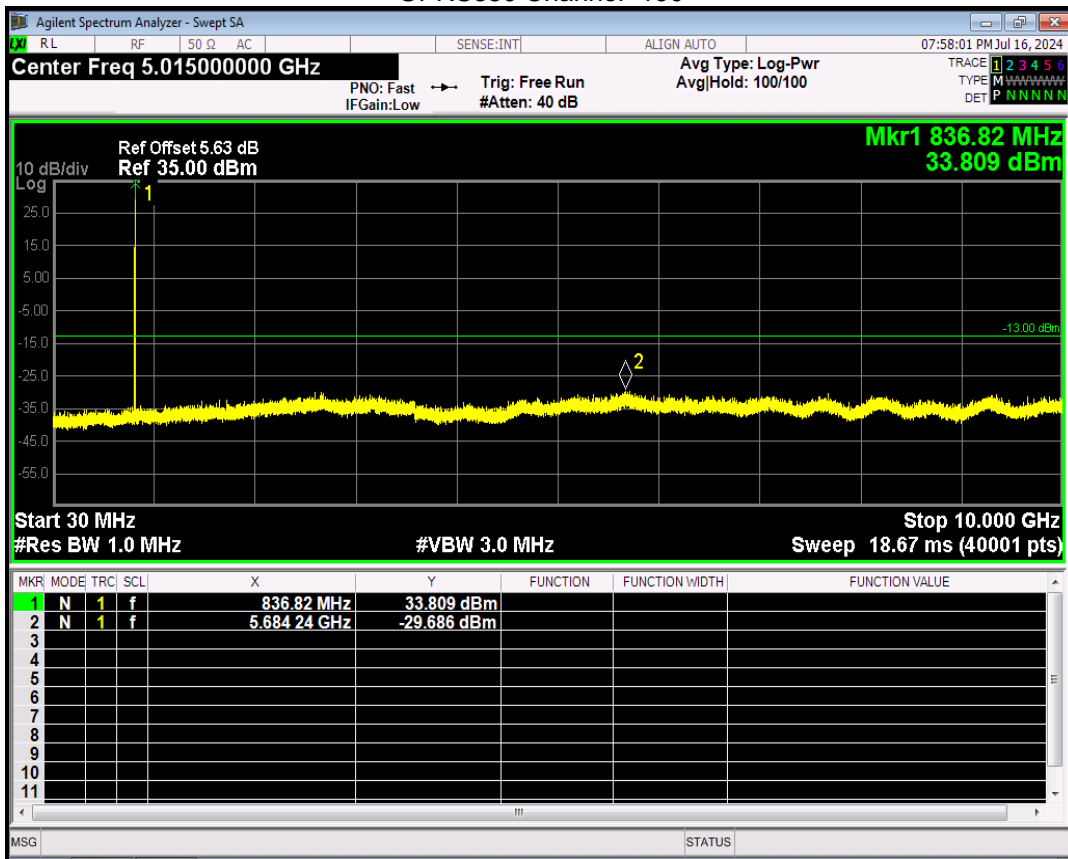

GPRS850 Channel=251

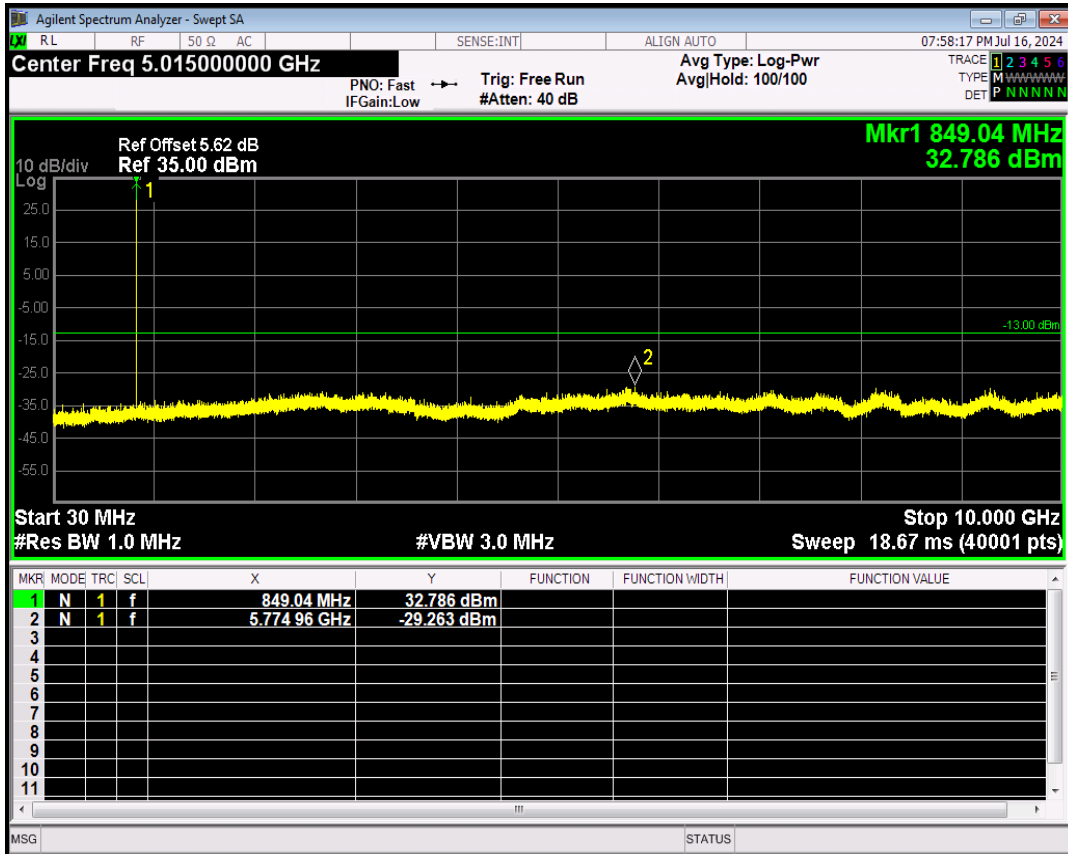

EGPRS1900 Channel=512

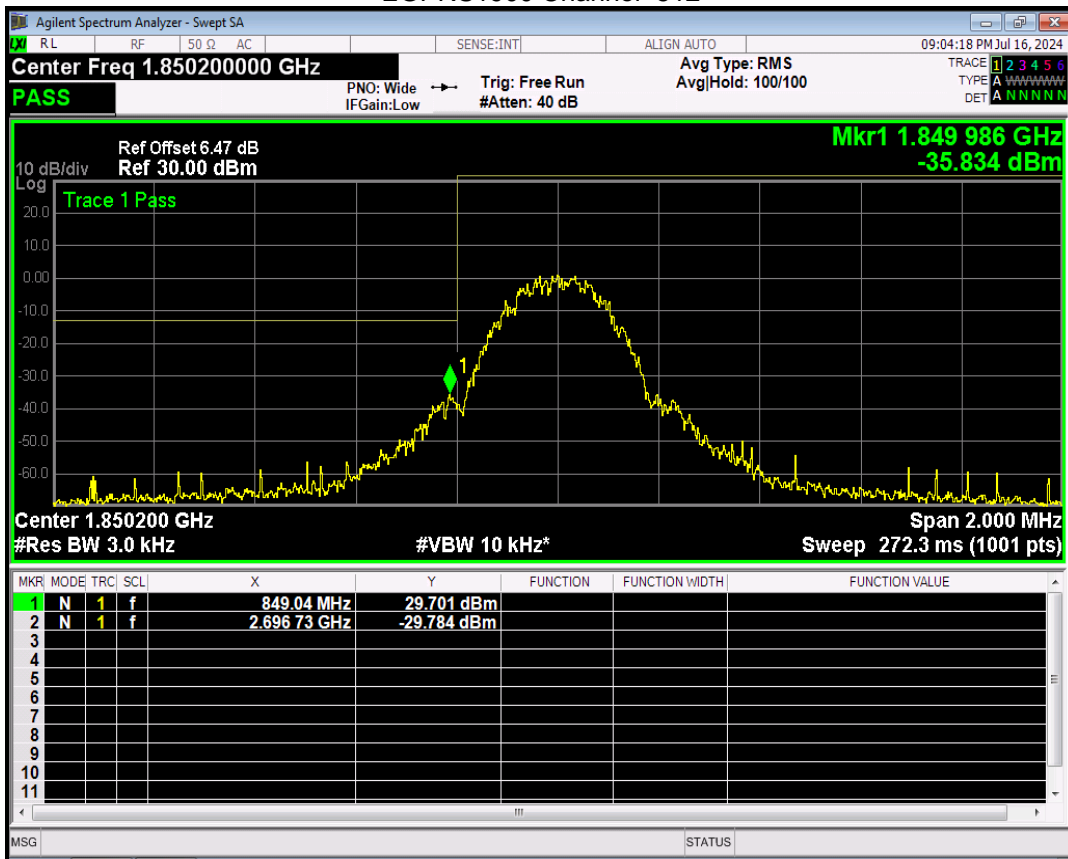

EGPRS1900 Channel=810

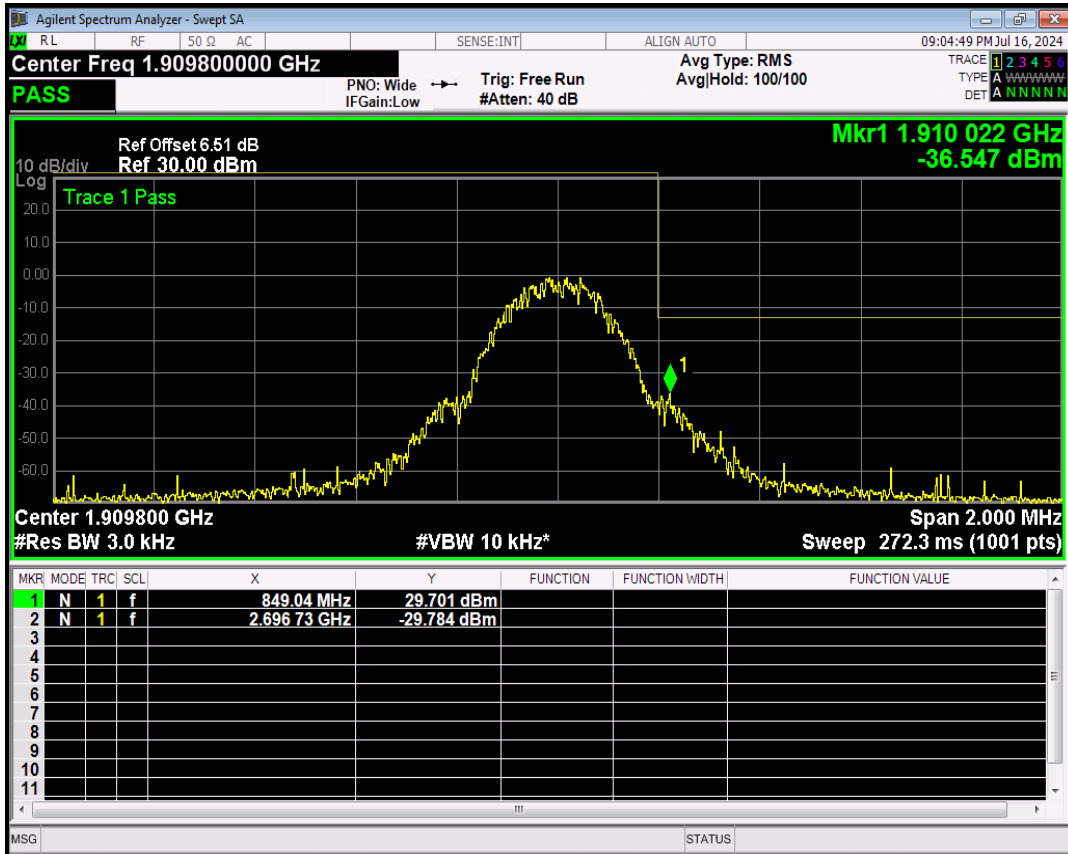

EGPRS850 Channel=128

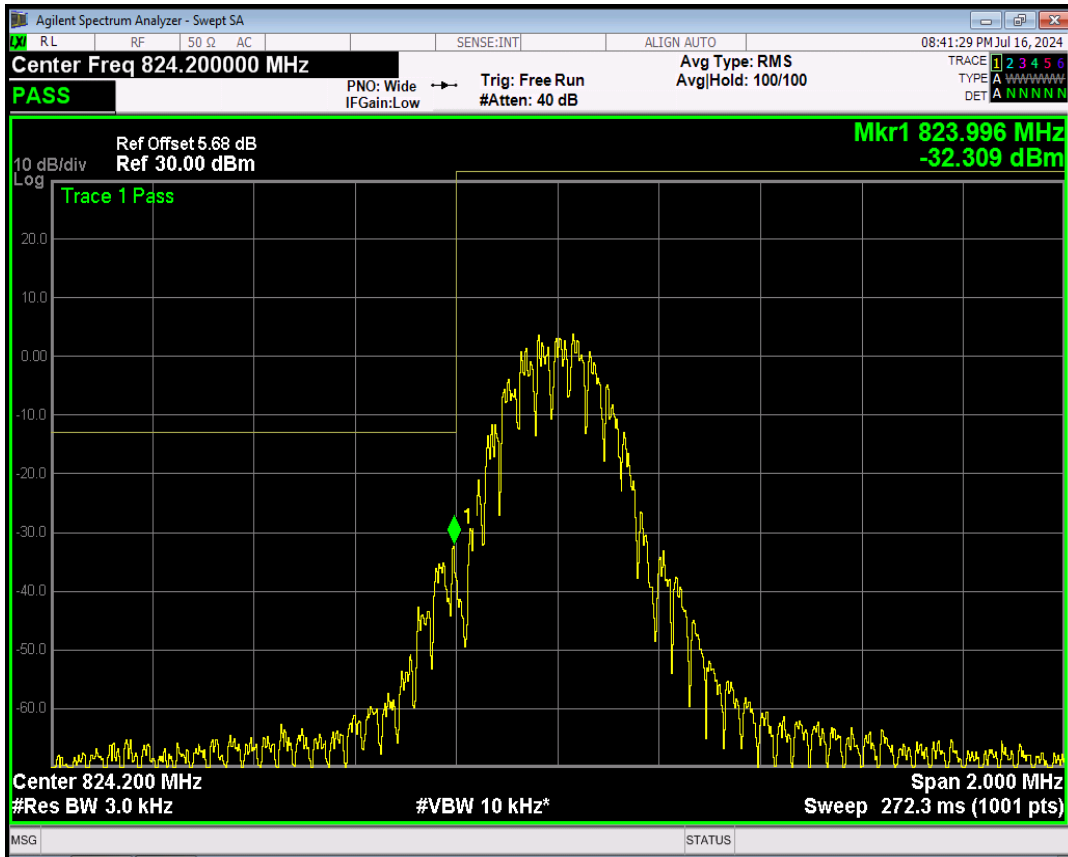

EGPRS850 Channel=251

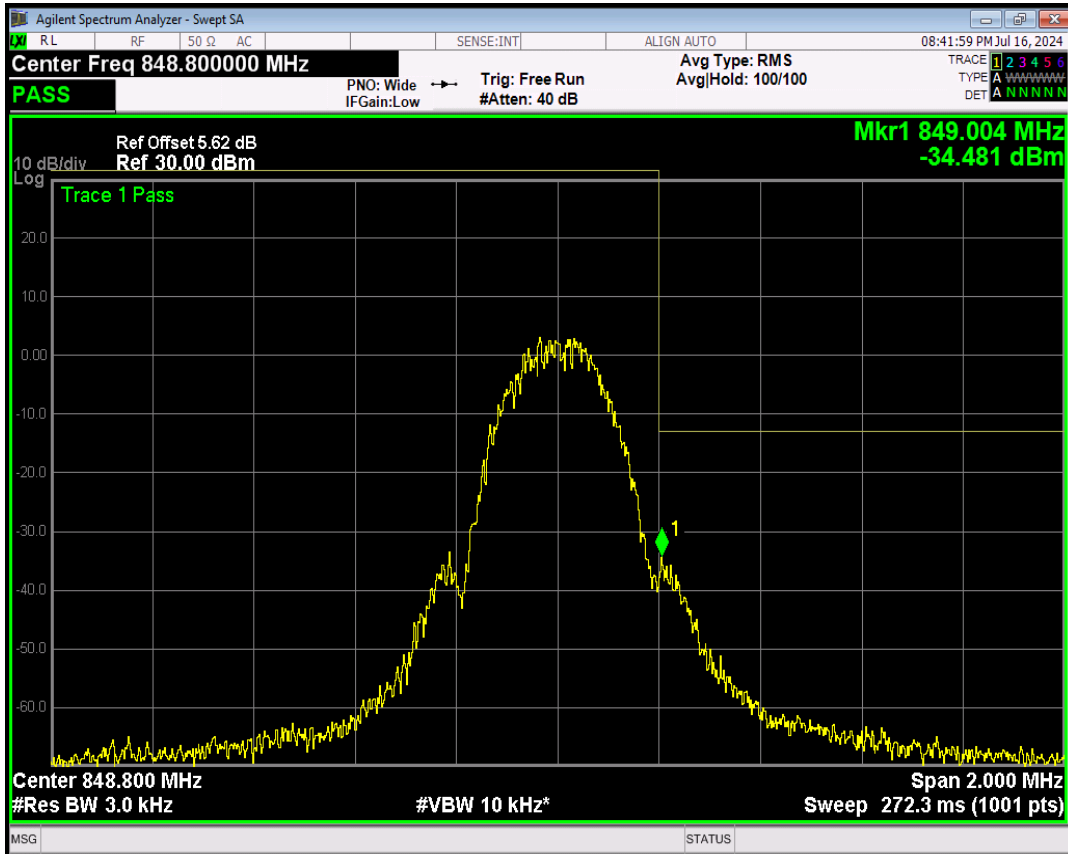

EGPRS1900 Channel=512

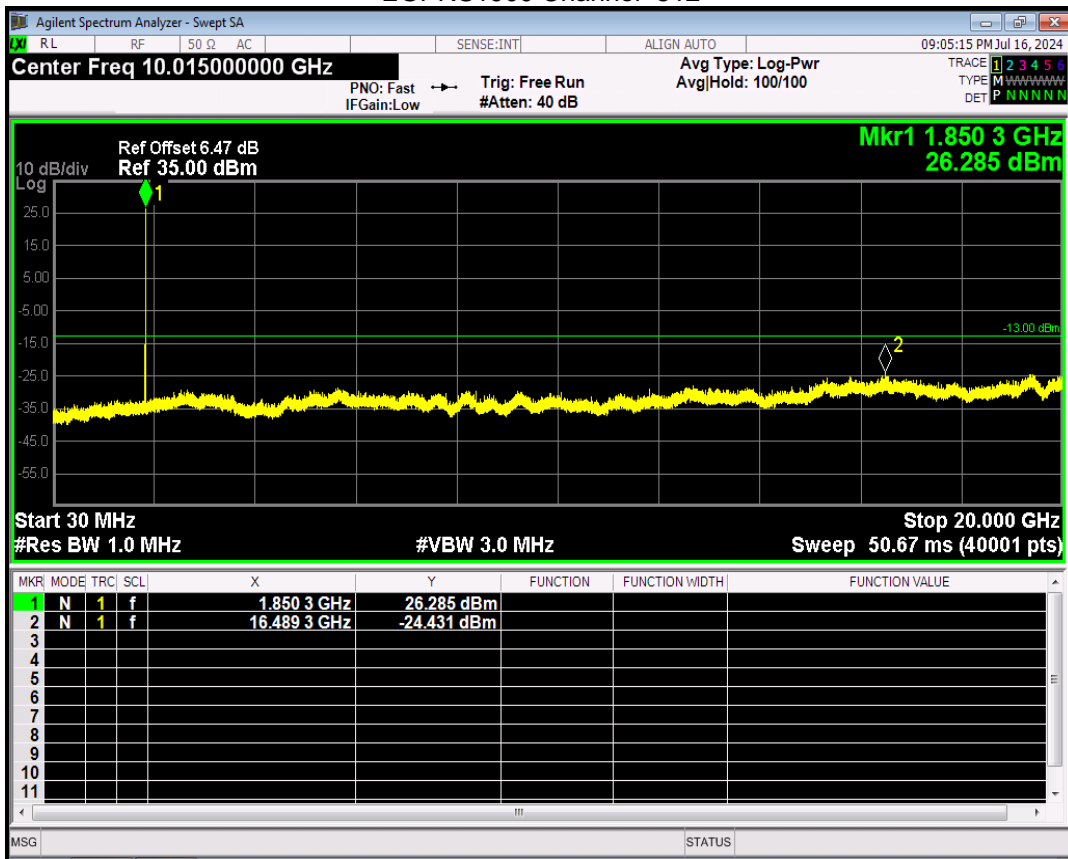

EGPRS1900 Channel=661

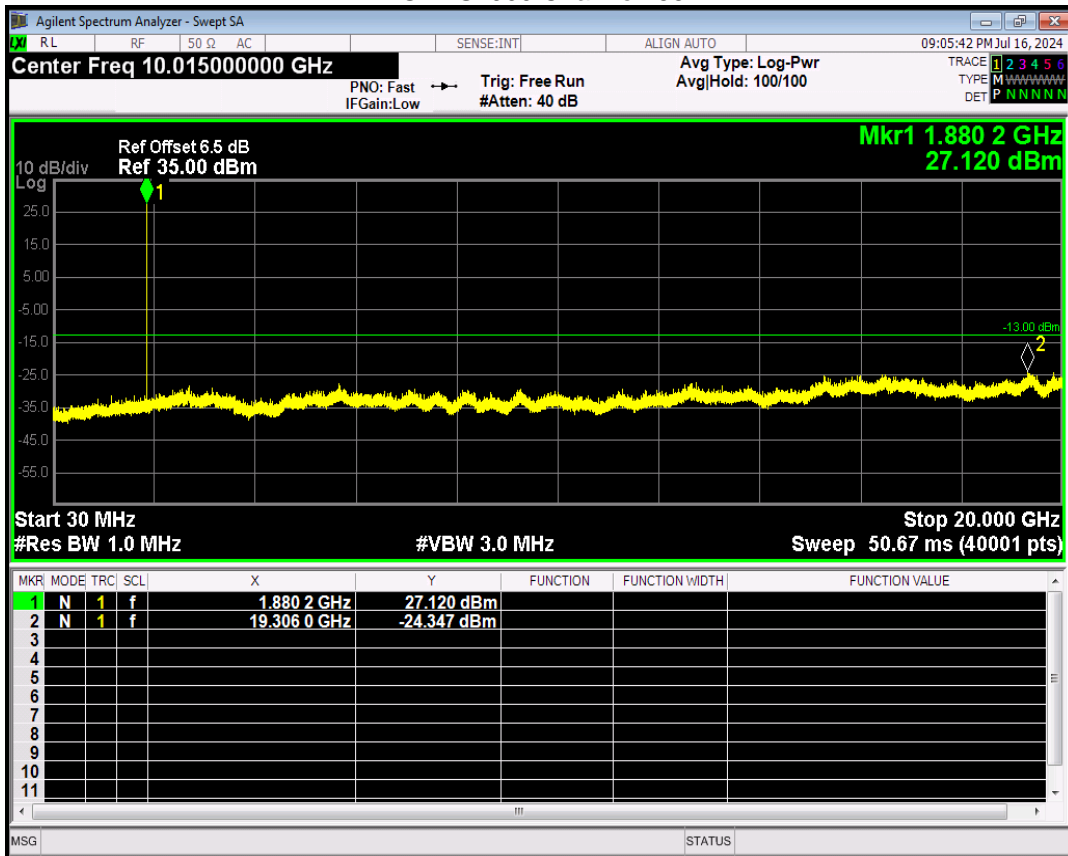

EGPRS1900 Channel=810

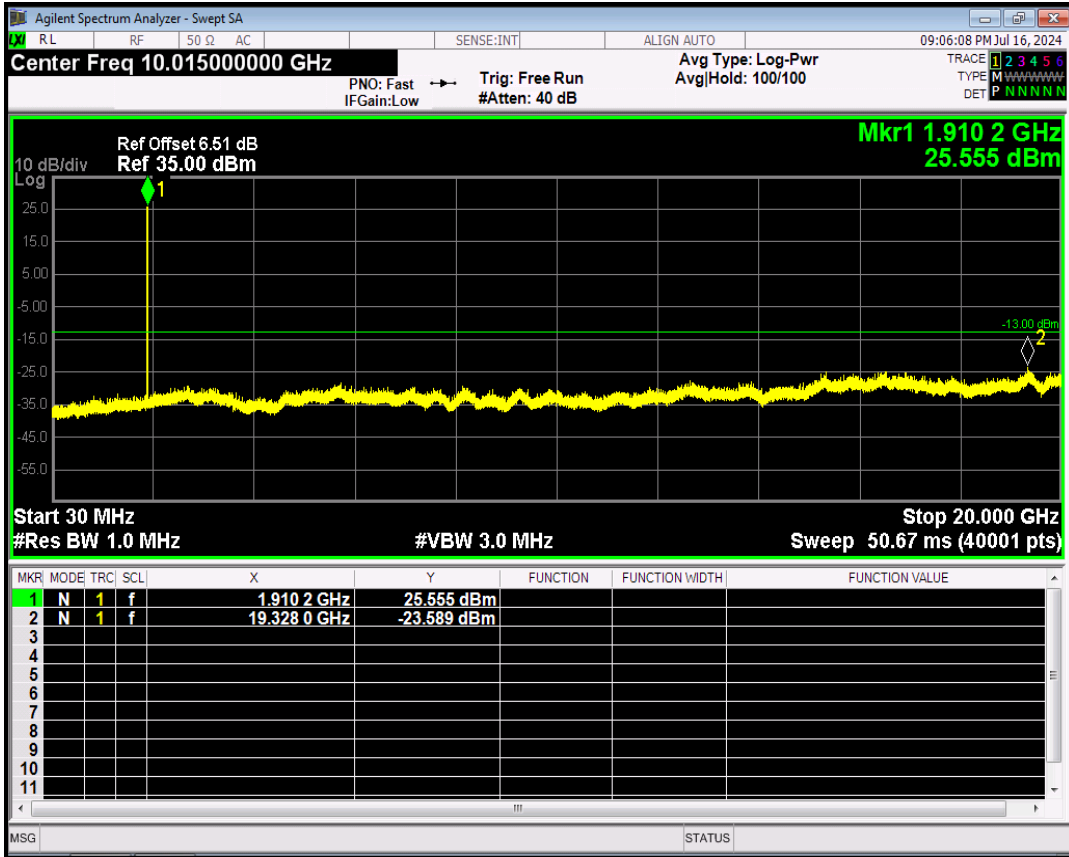

EGPRS850 Channel=128

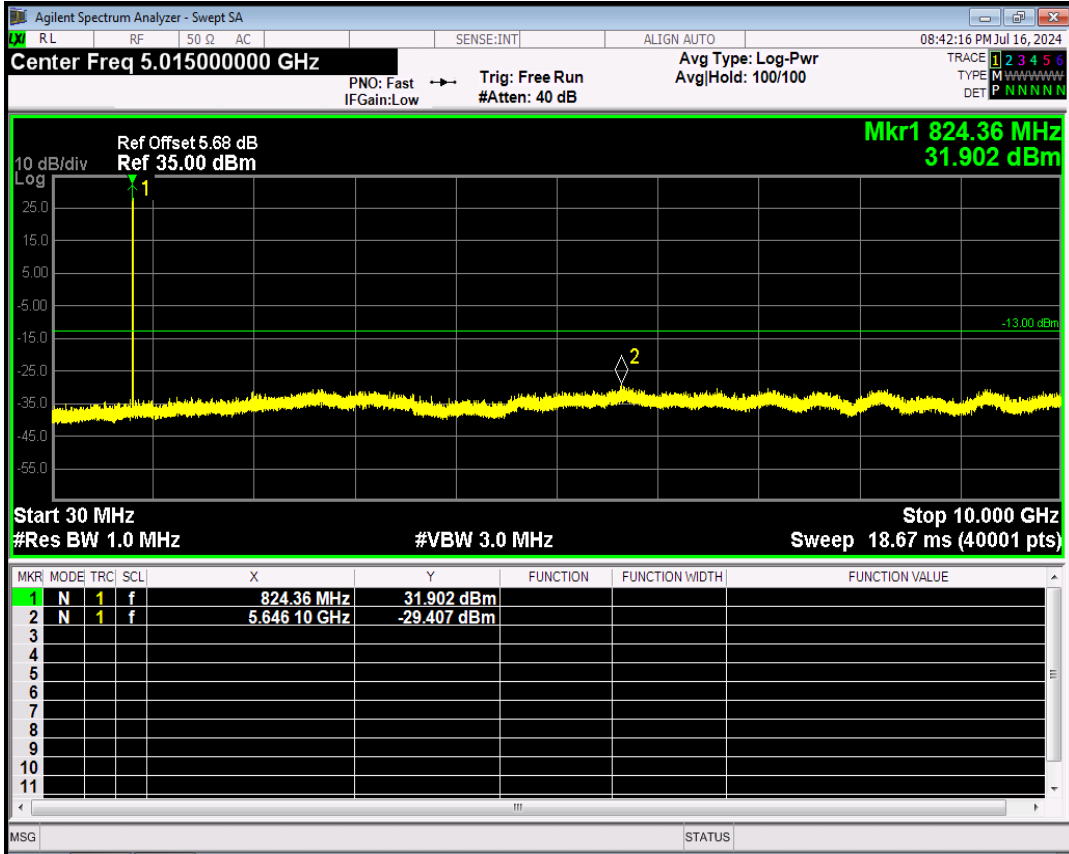

EGPRS850 Channel=190

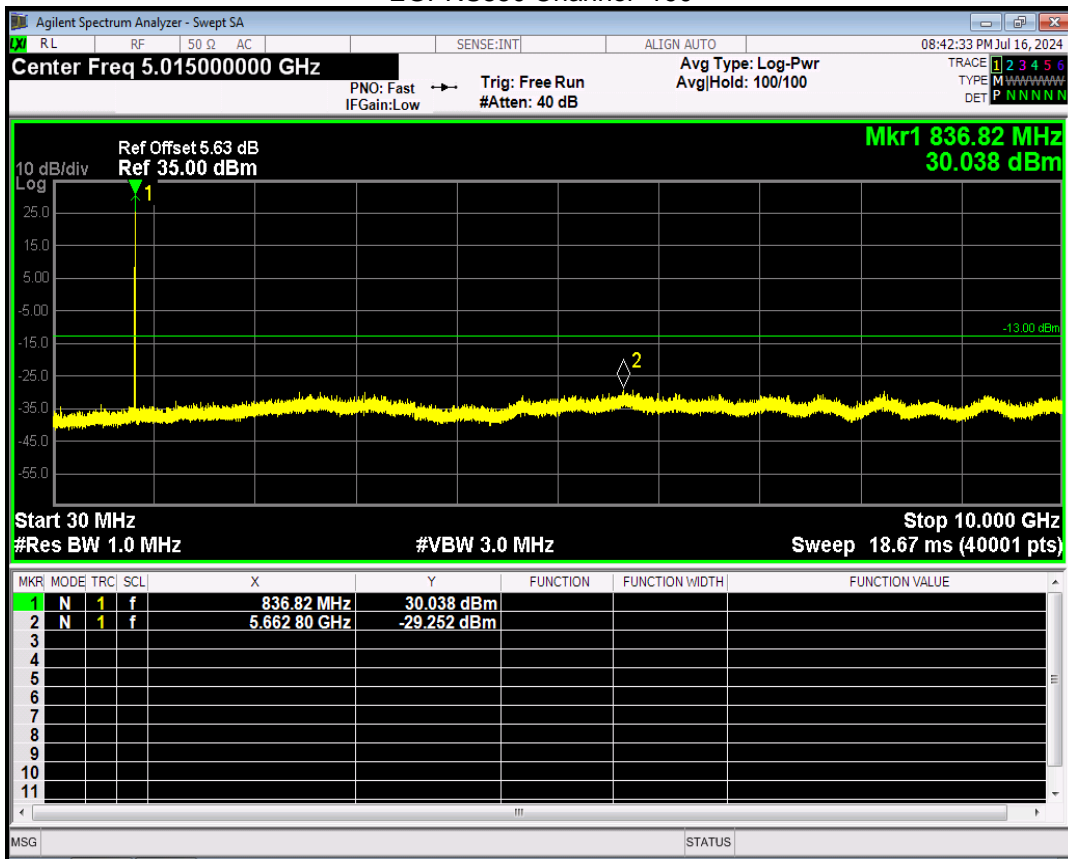

EGPRS850 Channel=251

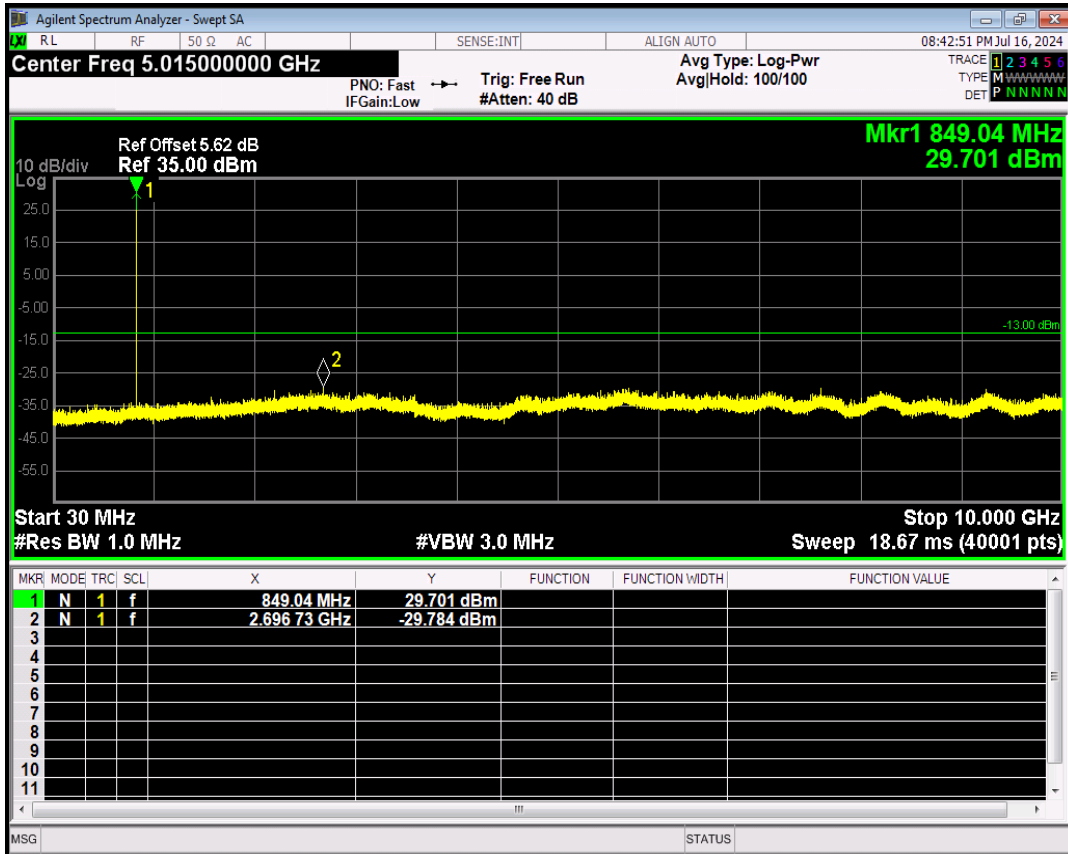

WCDMA Band2 Channel=9262

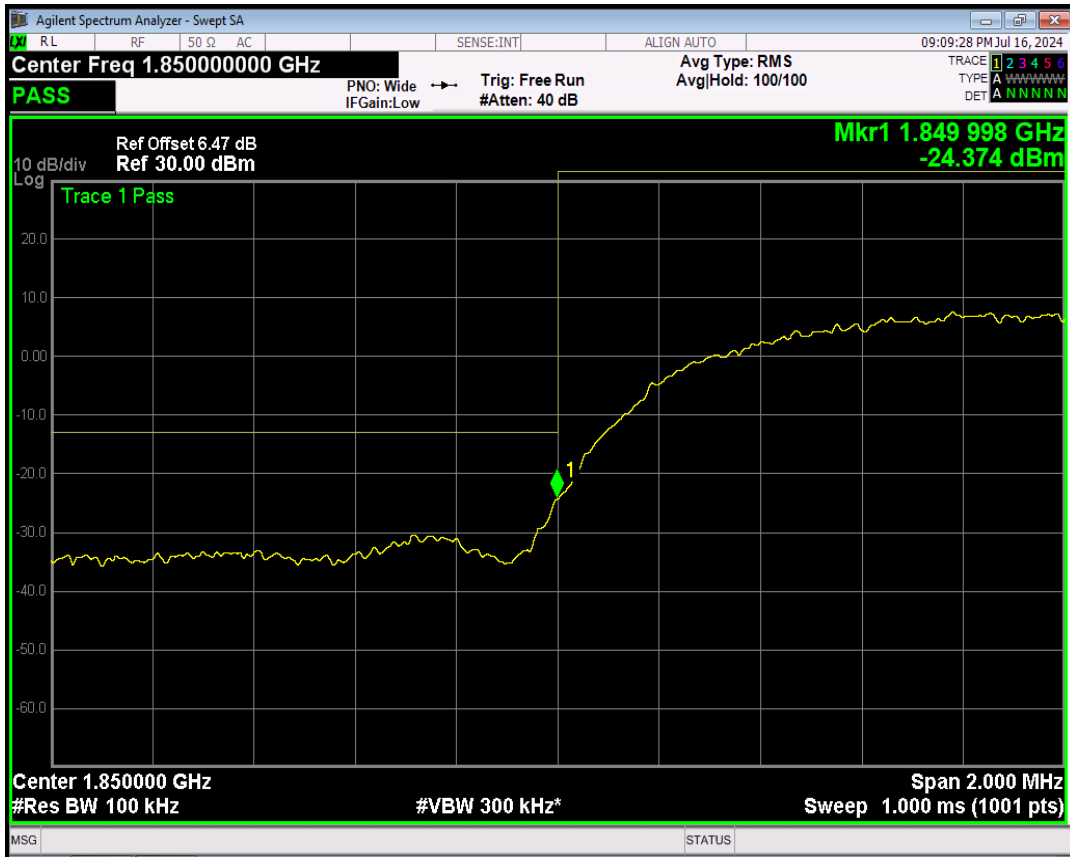

WCDMA Band2 Channel=9538



WCDMA Band2 Channel=9262

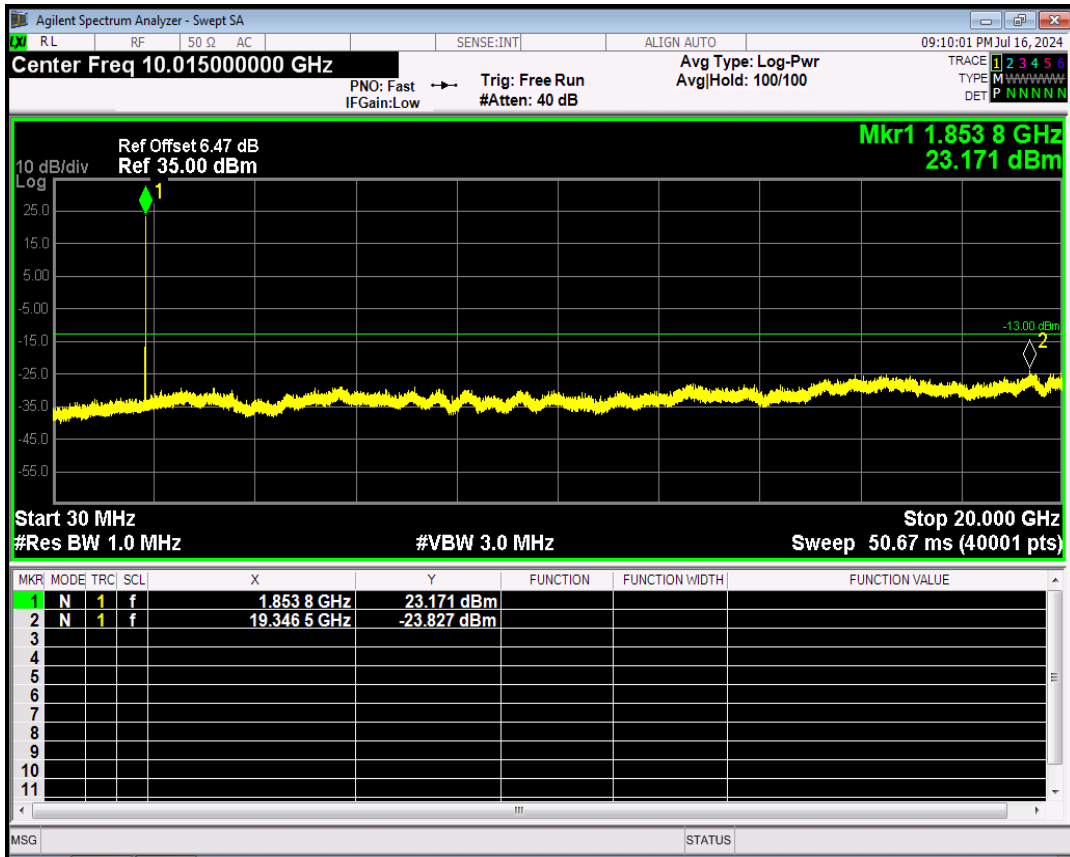

WCDMA Band2 Channel=9400

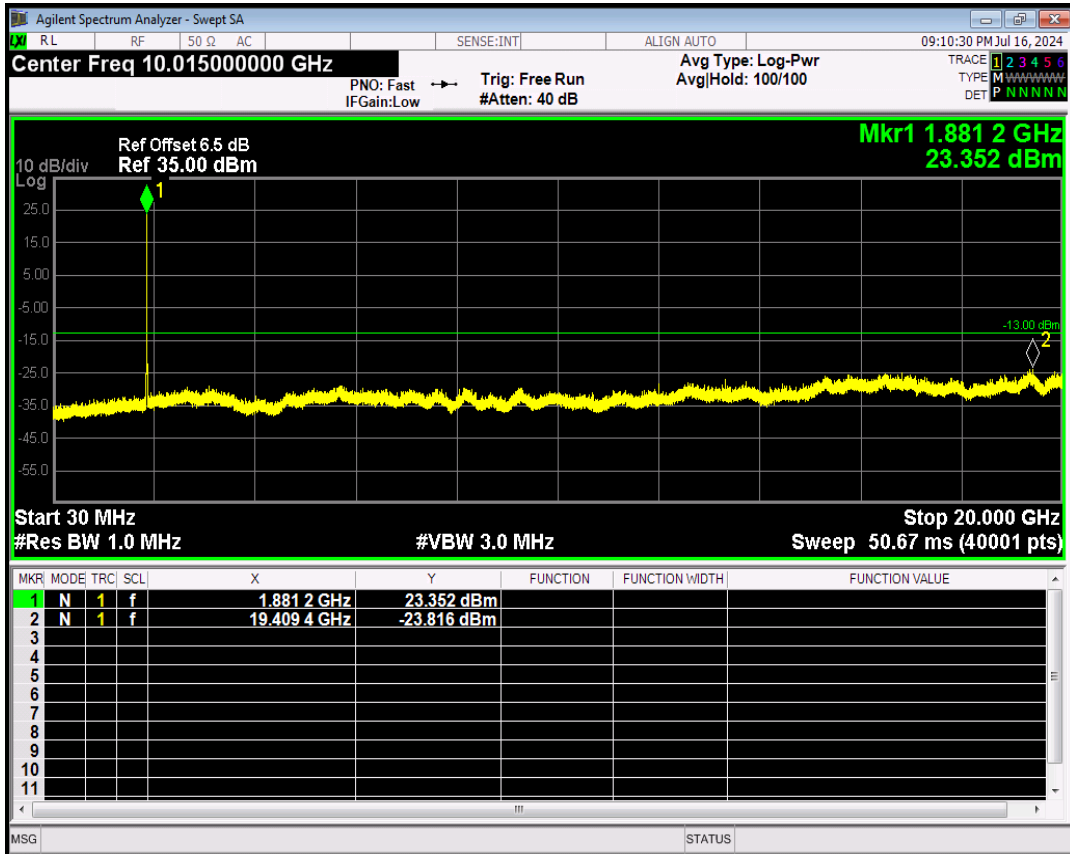

WCDMA Band2 Channel=9538

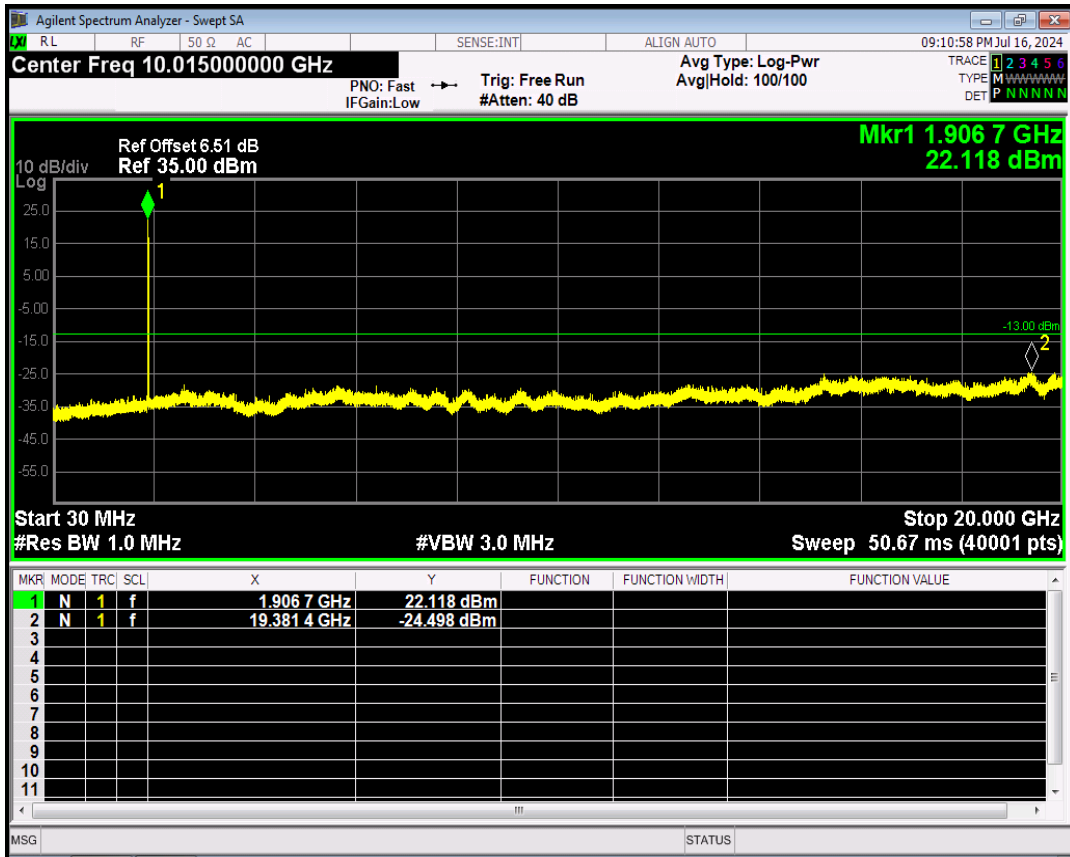

WCDMA Band4 Channel=1312

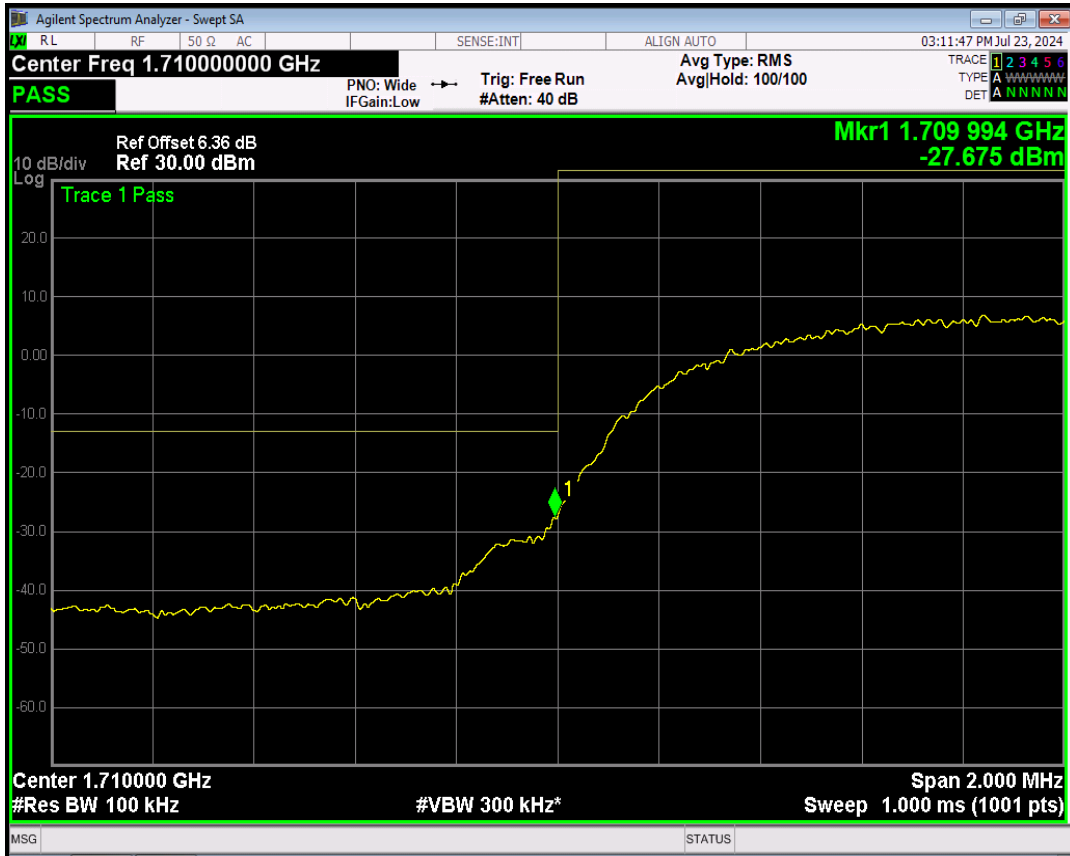

WCDMA Band4 Channel=1513



WCDMA Band4 Channel=1312

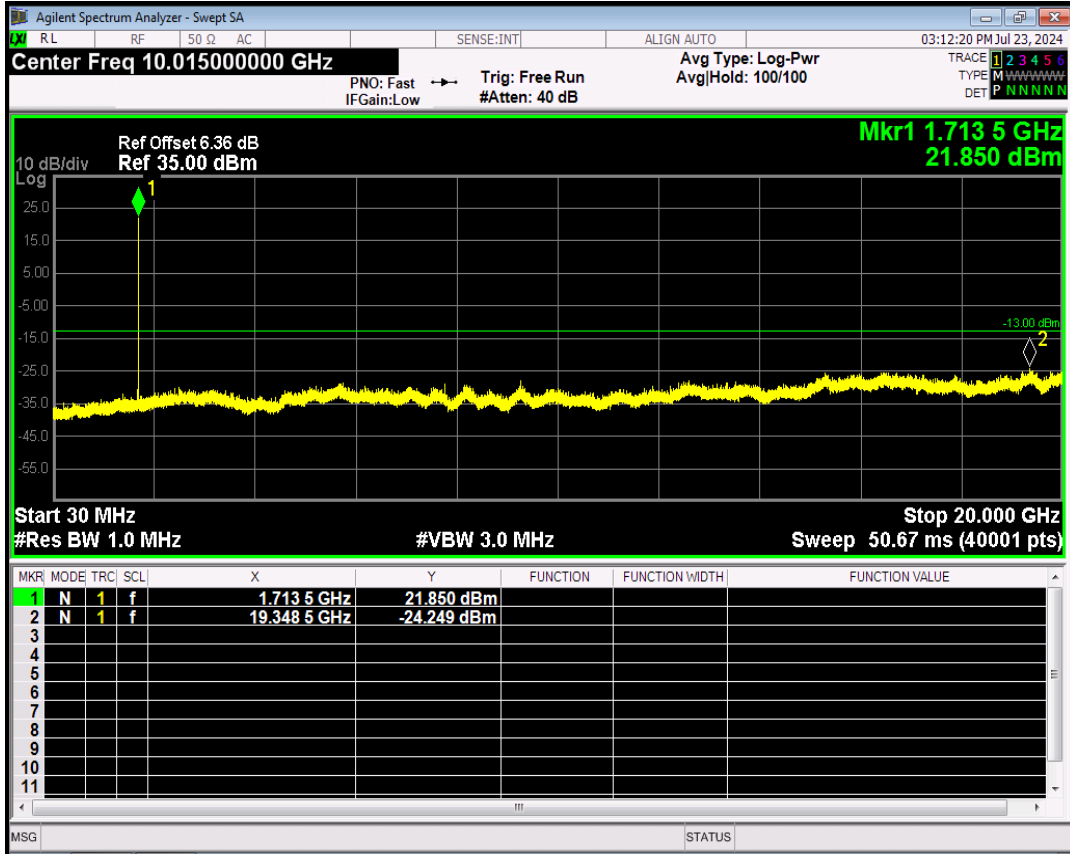

WCDMA Band4 Channel=1450

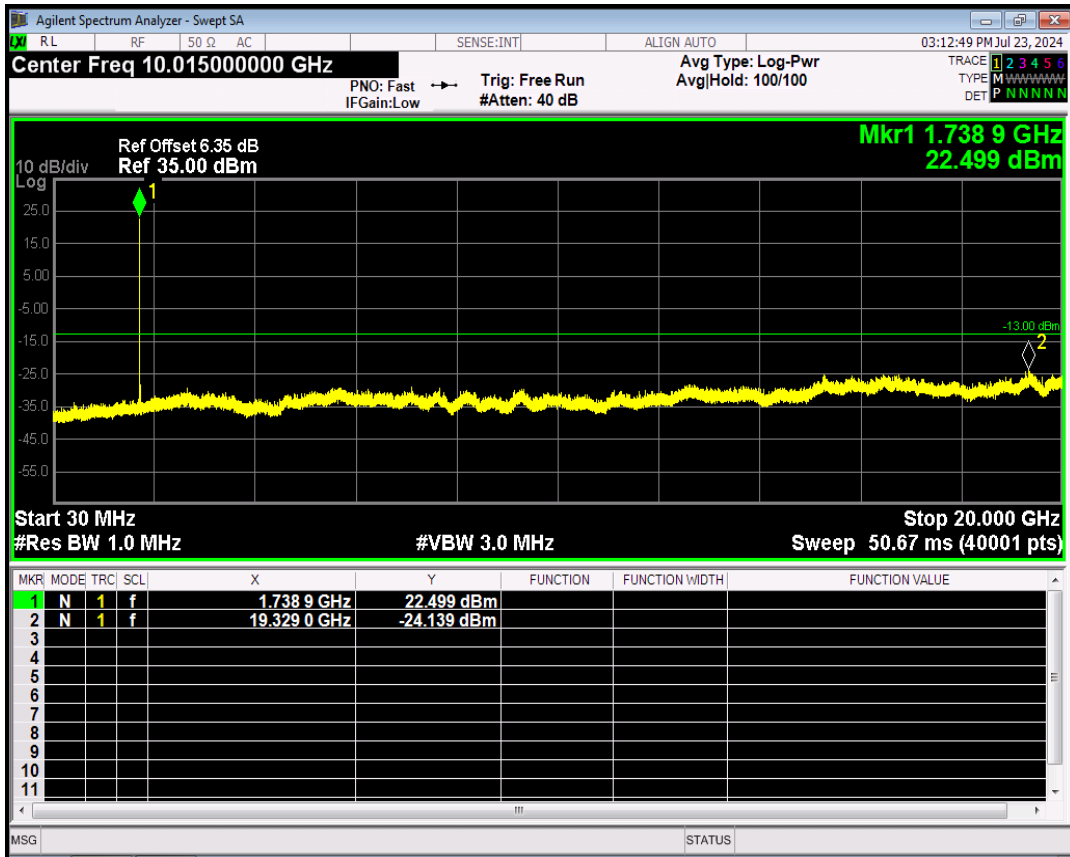

WCDMA Band4 Channel=1513

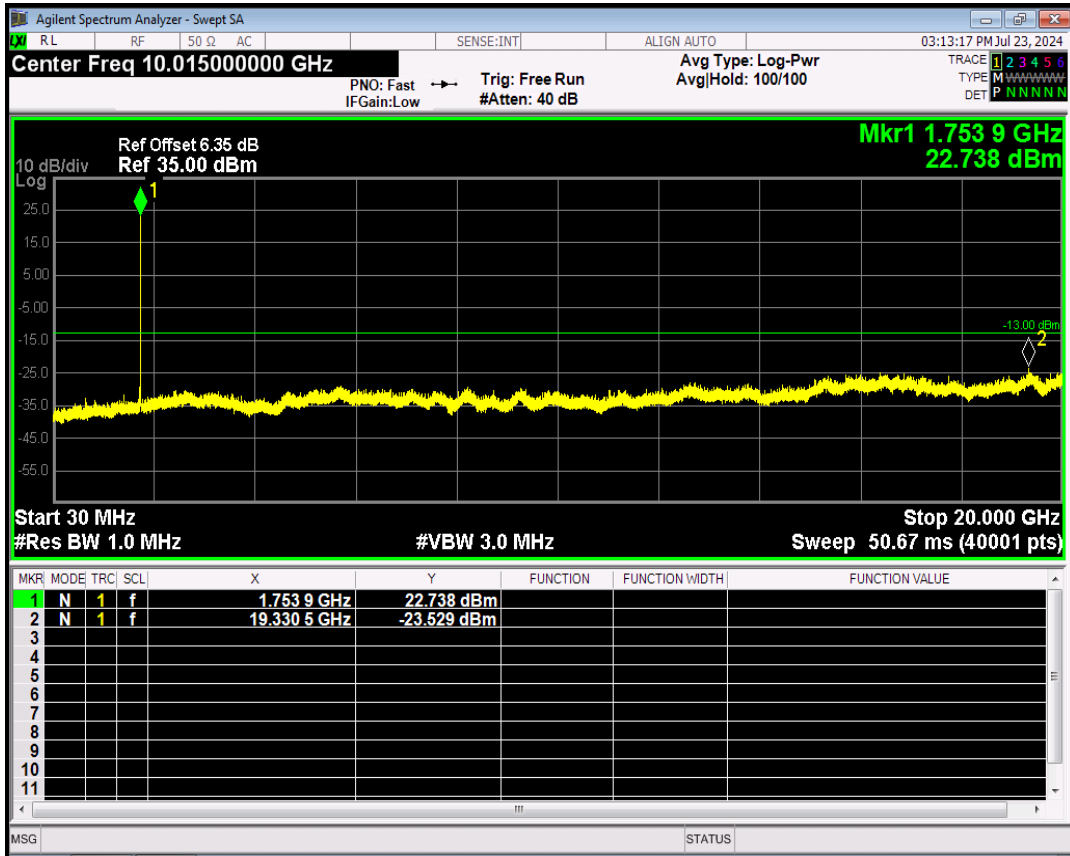

WCDMA Band5 Channel=4132

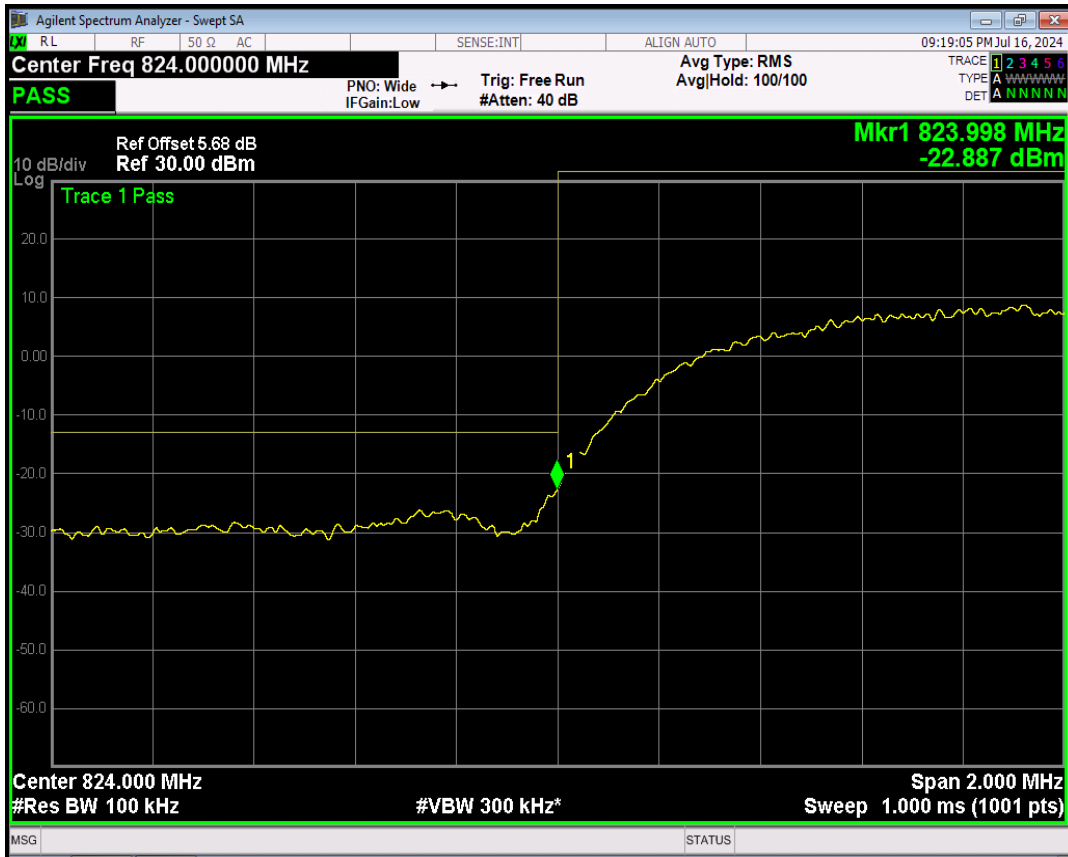

WCDMA Band5 Channel=4233



WCDMA Band5 Channel=4132

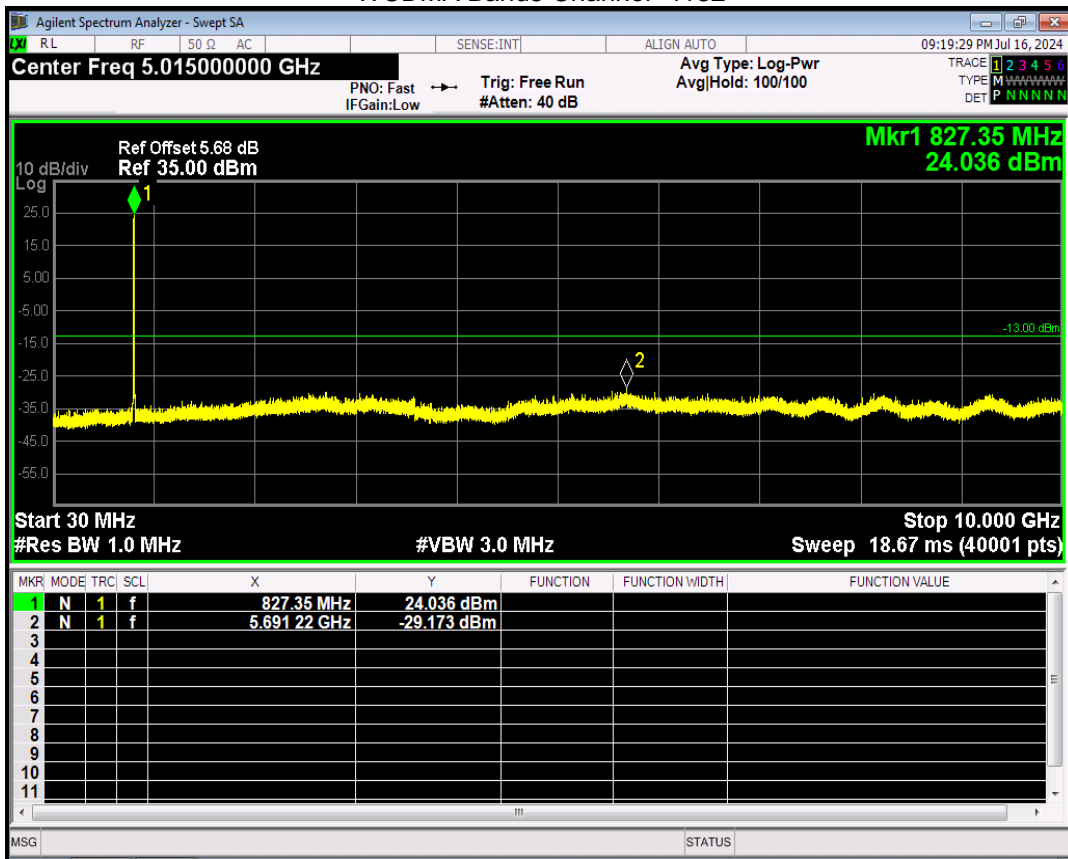

WCDMA Band5 Channel=4182

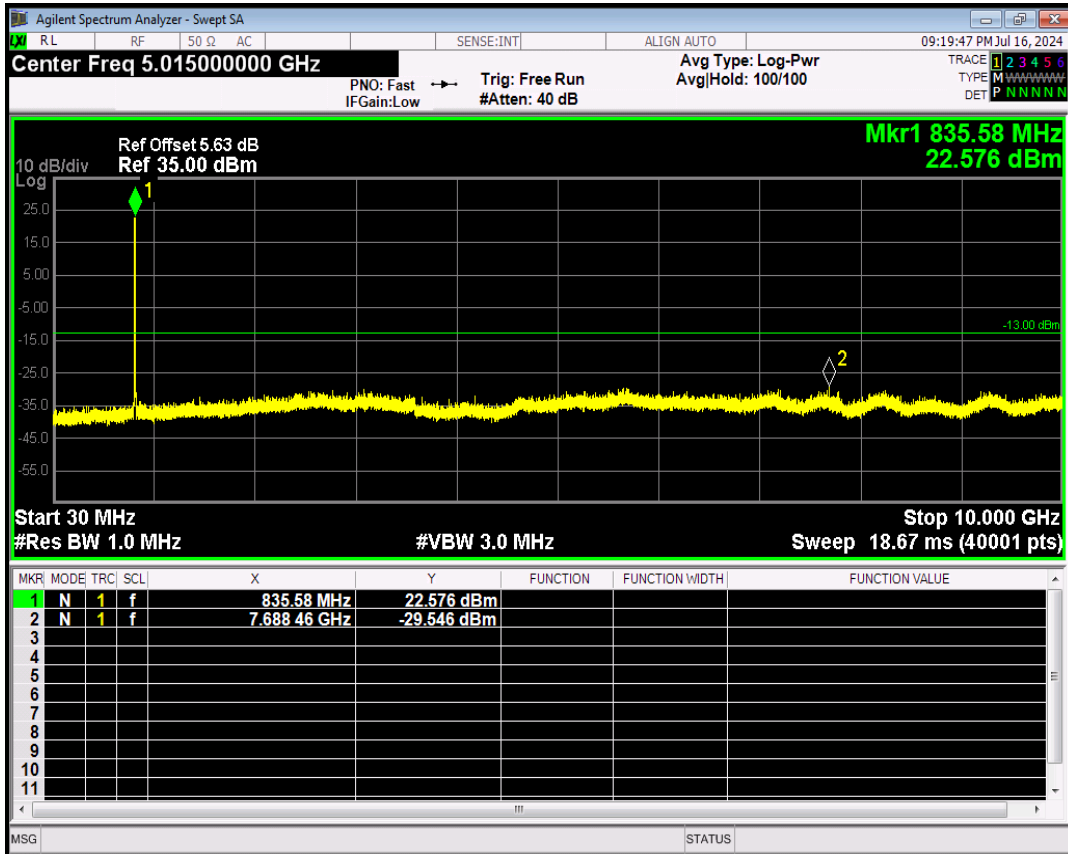

WCDMA Band5 Channel=4233

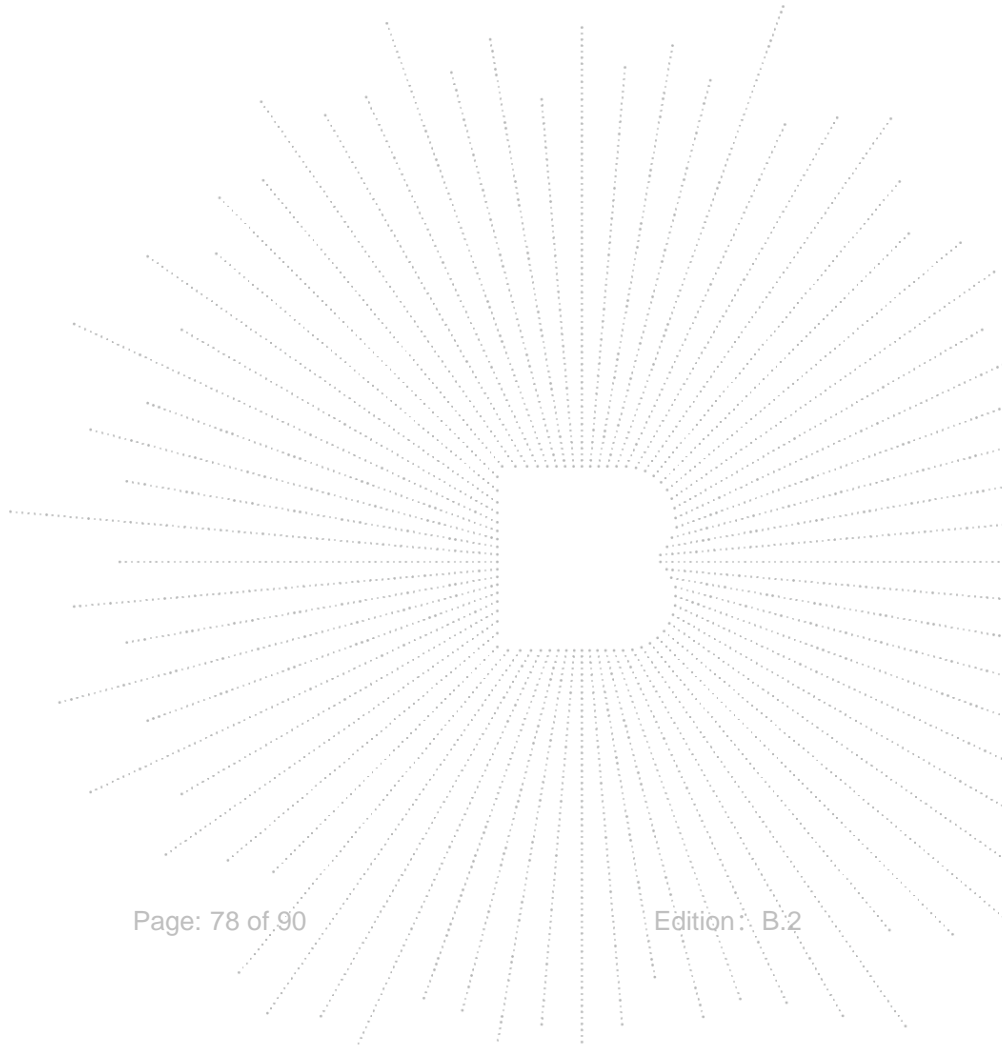
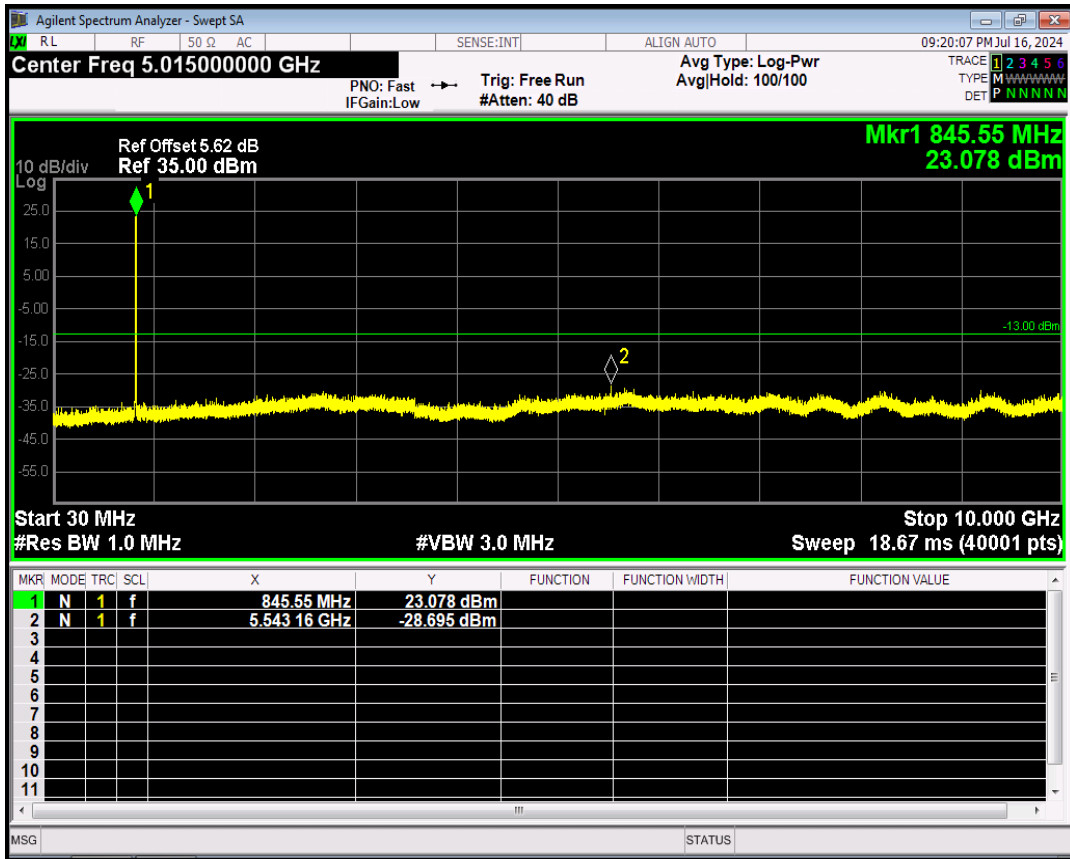

10. Spurious Radiated Emissions

10.1 Block Diagram Of Test Setup

(A) Radiated Emission Test-Up Frequency Below 30MHz

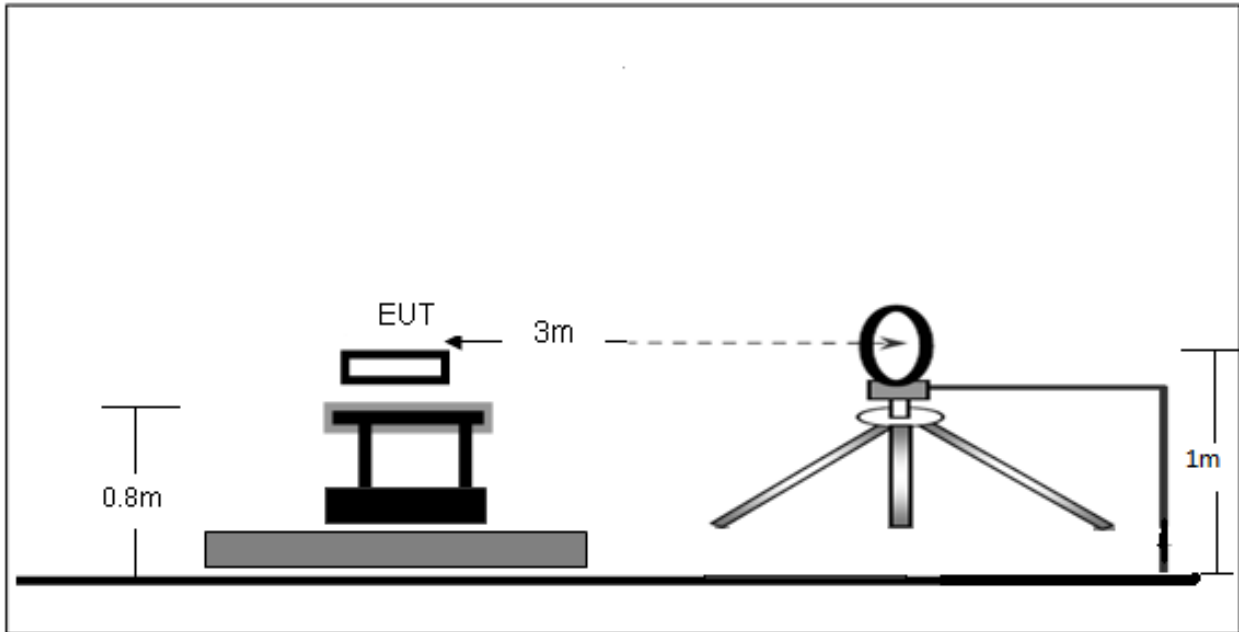

(B) Radiated Emission Test-Up Frequency 30MHz~1GHz

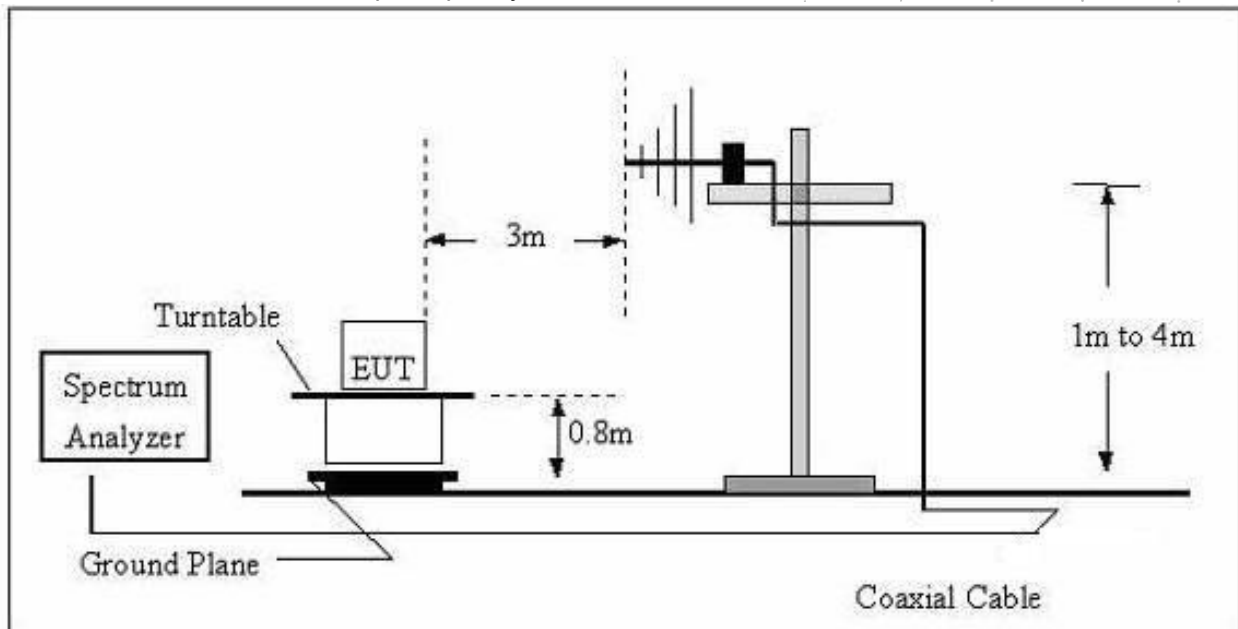

(C) Radiated Emission Test-Up Frequency Above 1GHz

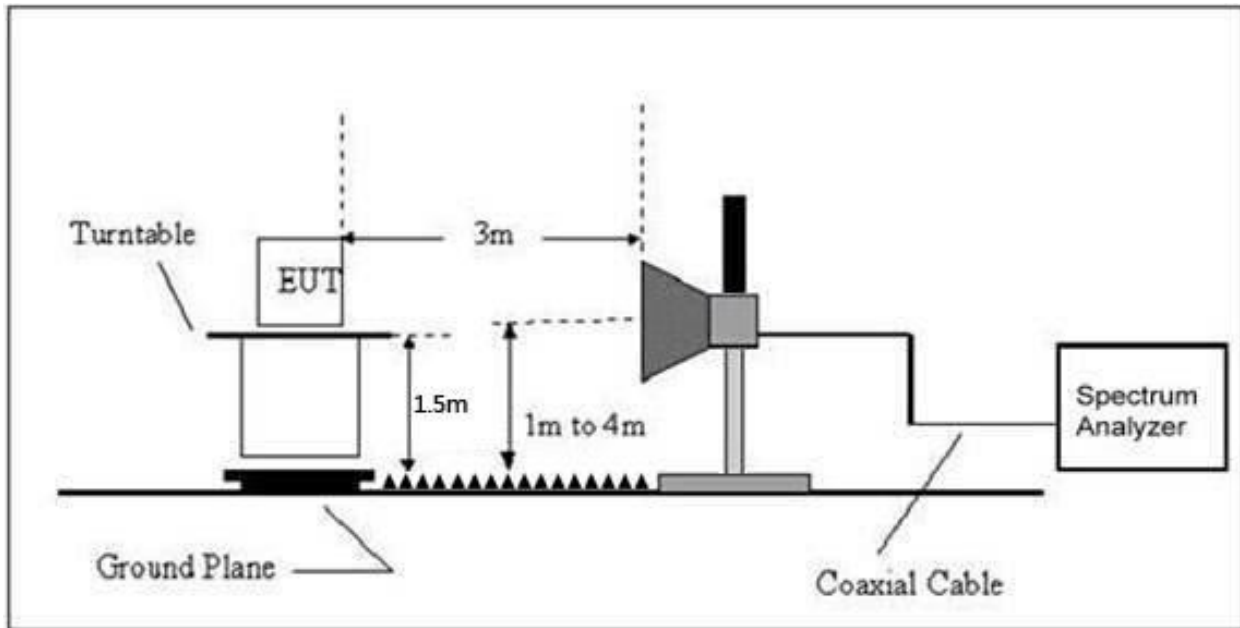

10.2 Limit

According to §22.917(a), the power of any emissions outside of the authorized operating frequency ranges must be attenuated below the transmitting power (P) by a factor of at least $43 + 10 \log(P)$ dB.

According to §24.238(a), the power of any emissions outside of the authorized operating frequency ranges must be attenuated below the transmitting power (P) by a factor of at least $43 + 10 \log(P)$ dB.

According to §27.53 (h), the power of any emission outside a licensee's frequency block shall be attenuated below the transmitter power (P) in watts by at least $43 + 10 \log_{10}(P)$ dB.

10.3 Test procedure

1. The setup of EUT is according with per ANSI/TIA Standard 603D and ANSI C63.4-2014 measurement procedure.
2. The measurement antenna was placed at a distance of 3 meters from the EUT. During the tests, the antenna height and polarization as well as EUT azimuth were varied in order to identify the maximum level of emissions from the EUT. The test was performed by placing the EUT on 3-orthogonal axis.
3. The frequency range up to tenth harmonic of the fundamental frequency was investigated.
4. Remove the EUT and replace it with substitution antenna. A signal generator was connected to the substitution antenna by a non-radiating cable. The absolute levels of the spurious emissions were measured by the substitution.

Spurious attenuation limit in dB = $43 + 10 \log_{10}(\text{power out in Watts})$

10.4 Test Result

For Cellular Band_GSM850 Mode

Frequency (MHz)	Reading (dBm)	Correct dB	Result (dBm)	Limit (dBm)	Margin (dB)	Polar H/V
Low Channel (824.2MHz)						
83.76	-23.36	-30.57	-53.93	-13.00	-40.93	H
1648.40	-18.77	-27.29	-46.06	-13.00	-33.06	H
2472.60	-25.71	-25.18	-50.89	-13.00	-37.89	H
83.76	-31.05	-30.57	-61.62	-13.00	-48.62	V
1648.40	-18.38	-27.29	-45.67	-13.00	-32.67	V
2472.60	-23.22	-25.18	-48.40	-13.00	-35.40	V
Middle Channel (836.6MHz)						
83.76	-29.18	-30.57	-59.75	-13.00	-46.75	H
1673.20	-19.97	-27.32	-47.29	-13.00	-34.29	H
2509.80	-25.65	-25.07	-50.72	-13.00	-37.72	H
83.76	-43.90	-30.57	-74.47	-13.00	-61.47	V
1673.20	-18.79	-27.32	-46.11	-13.00	-33.11	V
2509.80	-25.45	-25.07	-50.52	-13.00	-37.52	V
High Channel (848.8MHz)						
83.76	-41.51	-30.57	-72.08	-13.00	-59.08	H
1697.60	-18.24	-27.27	-45.51	-13.00	-32.51	H
2546.40	-26.70	-24.96	-51.66	-13.00	-38.66	H
83.76	-41.19	-30.57	-71.76	-13.00	-58.76	V
1697.60	-18.19	-27.27	-45.46	-13.00	-32.46	V
2546.40	-26.03	-24.96	-50.99	-13.00	-37.99	V

For PCS Band_GSM1900 Mode

Frequency (MHz)	Reading (dBm)	Correct dB	Result (dBm)	Limit (dBm)	Margin (dB)	Polar H/V
Low Channel (1850.2MHz)						
83.76	-33.61	-30.57	-64.18	-13.00	-51.18	H
3700.40	-26.55	-22.20	-48.75	-13.00	-35.75	H
5550.60	-30.15	-19.32	-49.47	-13.00	-36.47	H
83.76	-42.11	-30.57	-72.68	-13.00	-59.68	V
3700.40	-26.43	-22.20	-48.63	-13.00	-35.63	V
5550.60	-30.46	-19.32	-49.78	-13.00	-36.78	V
Middle Channel (1880MHz)						
83.76	-32.14	-30.57	-62.71	-13.00	-49.71	H
3760.00	-25.36	-22.08	-47.44	-13.00	-34.44	H
5640.00	-32.54	-19.28	-51.82	-13.00	-38.82	H
83.76	-44.22	-30.57	-74.79	-13.00	-61.79	V
3760.00	-27.69	-22.08	-49.77	-13.00	-36.77	V
5640.00	-29.32	-19.28	-48.60	-13.00	-35.60	V
High Channel (1909.8MHz)						
83.76	-32.00	-30.57	-62.57	-13.00	-49.57	H
3819.60	-25.30	-21.96	-47.26	-13.00	-34.26	H
5729.40	-32.70	-19.24	-51.94	-13.00	-38.94	H
83.76	-44.80	-30.57	-75.37	-13.00	-62.37	V
3819.60	-26.64	-21.96	-48.60	-13.00	-35.60	V
5729.40	-31.48	-19.24	-50.72	-13.00	-37.72	V

For Band WCDMA Band II Mode

Frequency (MHz)	Reading (dBm)	Correct dB	Result (dBm)	Limit (dBm)	Margin (dB)	Polar H/V
Low Channel (1852.4MHz)						
83.76	-43.54	-30.57	-74.11	-13.00	-61.11	H
3704.80	-24.97	-22.19	-47.16	-13.00	-34.16	H
5557.20	-32.61	-19.32	-51.93	-13.00	-38.93	H
83.76	-44.33	-30.57	-74.90	-13.00	-61.90	V
3704.80	-26.94	-22.19	-49.13	-13.00	-36.13	V
5557.20	-29.49	-19.32	-48.81	-13.00	-35.81	V
Middle Channel (1880MHz)						
83.76	-41.18	-30.57	-71.75	-13.00	-58.75	H
3760.00	-24.72	-22.08	-46.80	-13.00	-33.80	H
5640.00	-30.05	-19.28	-49.33	-13.00	-36.33	H
83.76	-44.06	-30.57	-74.63	-13.00	-61.63	V
3760.00	-26.06	-22.08	-48.14	-13.00	-35.14	V
5640.00	-28.55	-19.28	-47.83	-13.00	-34.83	V
High Channel (1907.6MHz)						
83.76	-41.60	-30.57	-72.17	-13.00	-59.17	H
3815.20	-26.51	-21.97	-48.48	-13.00	-35.48	H
5722.80	-30.76	-19.24	-50.00	-13.00	-37.00	H
83.76	-41.60	-30.57	-72.17	-13.00	-59.17	V
3815.20	-29.85	-21.97	-51.82	-13.00	-38.82	V
5722.80	-28.82	-19.24	-48.06	-13.00	-35.06	V

Note: Result=Reading+ Correct, Margin= Result- Limit

For Band WCDMA Band IV Mode

Frequency (MHz)	Reading (dBm)	Correct dB	Result (dBm)	Limit (dBm)	Margin (dB)	Polar H/V
Low Channel (1712.4MHz)						
83.76	-42.32	-30.57	-72.89	-13.00	-59.89	H
3424.80	-24.94	-22.75	-47.69	-13.00	-34.69	H
5137.20	-30.54	-19.53	-50.07	-13.00	-37.07	H
83.76	-44.82	-30.57	-75.39	-13.00	-62.39	V
3424.80	-27.00	-22.75	-49.75	-13.00	-36.75	V
5137.20	-29.45	-19.53	-48.98	-13.00	-35.98	V
Middle Channel (1740MHz)						
83.76	-43.27	-30.57	-73.84	-13.00	-60.84	H
3480.00	-27.31	-22.64	-49.95	-13.00	-36.95	H
5220.00	-29.02	-19.49	-48.51	-13.00	-35.51	H
83.76	-44.38	-30.57	-74.95	-13.00	-61.95	V
3480.00	-27.00	-22.64	-49.64	-13.00	-36.64	V
5220.00	-30.42	-19.49	-49.91	-13.00	-36.91	V
High Channel (1752.6MHz)						
83.76	-42.35	-30.57	-72.92	-13.00	-59.92	H
3505.20	-27.97	-22.59	-50.56	-13.00	-37.56	H
5257.80	-29.58	-19.47	-49.05	-13.00	-36.05	H
83.76	-42.65	-30.57	-73.22	-13.00	-60.22	V
3505.20	-26.82	-22.59	-49.41	-13.00	-36.41	V
5257.80	-31.90	-19.47	-51.37	-13.00	-38.37	V

Note: Result=Reading+ Correct, Margin= Result- Limit

For Band WCDMA Band V Mode

Frequency (MHz)	Reading (dBm)	Correct dB	Result (dBm)	Limit (dBm)	Margin (dB)	Polar H/V
Low Channel (826.4MHz)						
83.76	-41.84	-30.57	-72.41	-13.00	-59.41	H
1652.80	-18.05	-27.36	-45.41	-13.00	-32.41	H
2479.20	-23.10	-25.16	-48.26	-13.00	-35.26	H
83.76	-42.57	-30.57	-73.14	-13.00	-60.14	V
1652.80	-18.02	-27.36	-45.38	-13.00	-32.38	V
2479.20	-23.79	-25.16	-48.95	-13.00	-35.95	V
Middle Channel (836.4MHz)						
83.76	-44.55	-30.57	-75.12	-13.00	-62.12	H
1672.80	-19.17	-27.32	-46.49	-13.00	-33.49	H
2509.20	-26.19	-25.07	-51.26	-13.00	-38.26	H
83.76	-43.92	-30.57	-74.49	-13.00	-61.49	V
1672.80	-20.12	-27.32	-47.44	-13.00	-34.44	V
2509.20	-23.84	-25.07	-48.91	-13.00	-35.91	V
High Channel (846.6MHz)						
83.76	-41.23	-30.57	-71.80	-13.00	-58.80	H
1693.20	-19.26	-27.27	-46.53	-13.00	-33.53	H
2539.80	-25.37	-24.98	-50.35	-13.00	-37.35	H
83.76	-42.37	-30.57	-72.94	-13.00	-59.94	V
1693.20	-21.72	-27.27	-48.99	-13.00	-35.99	V
2539.80	-25.78	-24.98	-50.76	-13.00	-37.76	V

Note: Result=Reading+ Correct, Margin= Result- Limit

Note: Testing is carried out with frequency rang 9kHz to the tenth harmonics, other than listed in the table above are attenuated more than 20dB below the permissible limits or the field strength is too small to be measured.

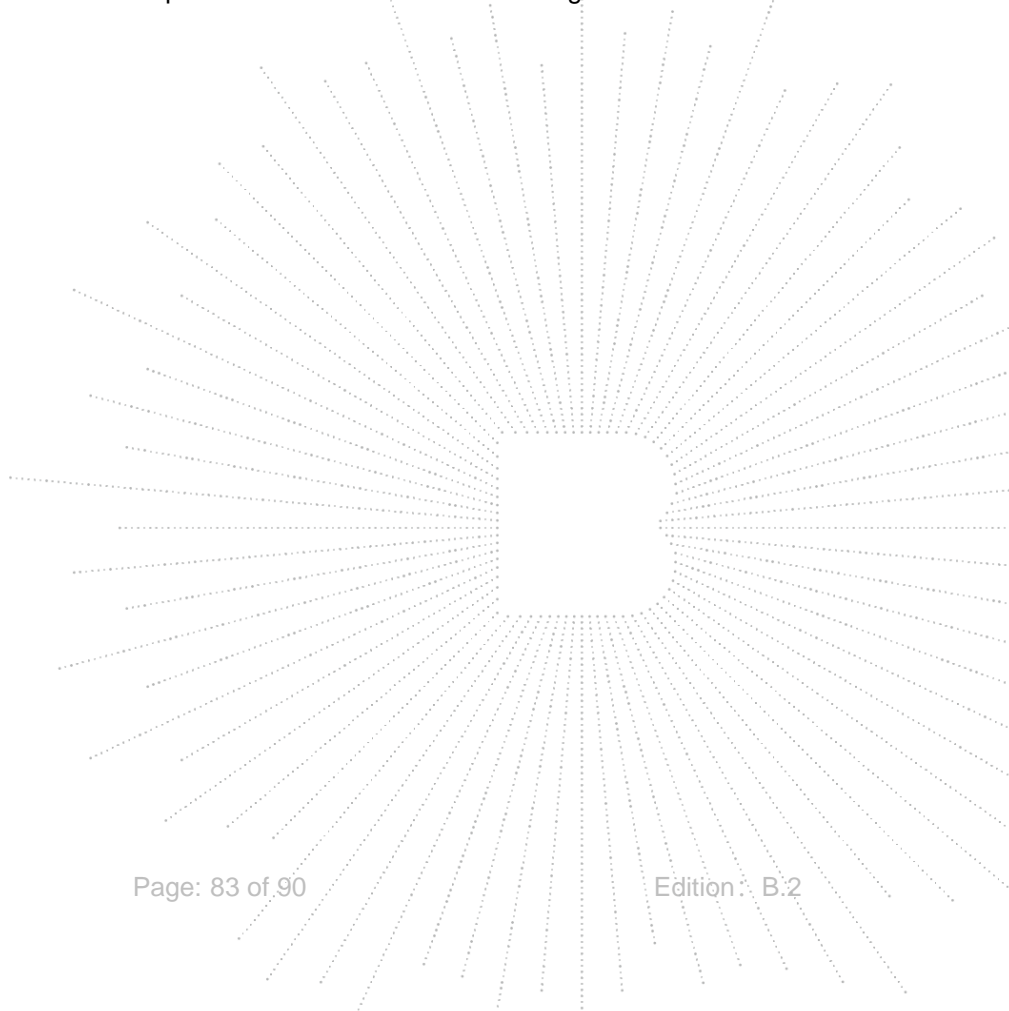

11. Frequency Stability

11.1 Block Diagram Of Test Setup

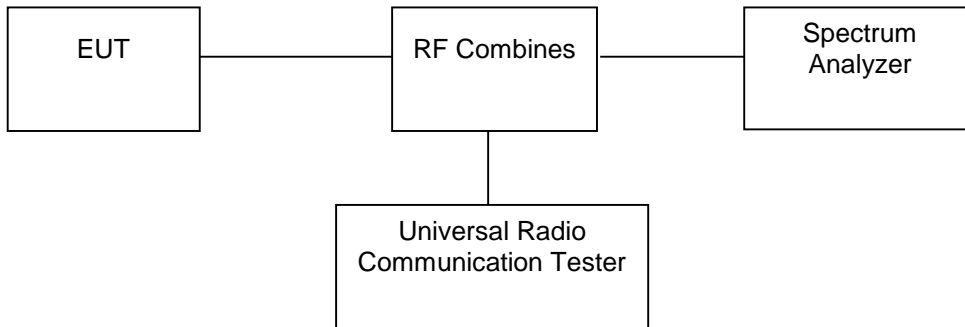

11.2 Limit

FCC Part 22.355: ± 2.5 ppm

FCC Part 24.235:

The frequency stability shall be sufficient to ensure that the fundamental emission stays within the authorized frequency block.

FCC Part 27.54

The frequency stability shall be sufficient to ensure that the fundamental emissions stay within the authorized bands of operation.

11.3 Test procedure

1. The testing follows FCC KDB 971168 D01v03r01 Section 9.0.
2. The EUT was set up in the thermal chamber and connected with the system simulator.
3. With power OFF, the temperature was decreased to -30°C and the EUT was stabilized before testing. Power was applied and the maximum change in frequency was recorded within one minute.
4. With power OFF, the temperature was raised in 10°C steps up to 50°C . The EUT was stabilized at each step for at least half an hour. Power was applied and the maximum frequency change was recorded within one minute.

Test Procedures for Voltage Variation

1. The testing follows FCC KDB 971168 D01v03r01 Section 9.0.
2. The EUT was placed in a temperature chamber at $25 \pm 5^{\circ}\text{C}$ and connected with the system simulator.
3. The power supply voltage to the EUT was varied from BEP to 115% of the nominal value measured at the input to the EUT.
4. The variation in frequency was measured for the worst case.