

FCC CFR47 PART 22H, 24E, 27 CERTIFICATION TEST REPORT

FCC ID: 2ANMU-RT8

Product: Tablet

Trade Mark: OUKITEL

Model Number: RT8

Family Model: RT8 S, RT8 Pro, RT8 Ultra, RT8 TITAN

Report No.: S23112302714006

Prepared for

SHENZHEN YUNJI INTELLIGENT TECHNOLOGY CO.,LTD
A2 2F BUILDING ENET NEW INDUSTRIAL PARK, DAFU INDUSTRIAL
ZONE, GUANLAN, LONGHUA SHENZHEN, 518XXX China

Prepared by

Shenzhen NTEK Testing Technology Co., Ltd.
1&5/F, Building C, 1&2/F, Building E, Fenda Science Park, Sanwei
Community, Hangcheng Street, Baoan District, Shenzhen ,Guangdong,
China

Tel. 400-800-6106, 0755-2320 0050, 0755-2320 0090

Website: <http://www.ntek.org.cn>

TEST RESULT CERTIFICATION

Applicant's name.....: SHENZHEN YUNJI INTELLIGENT TECHNOLOGY CO.,LTD
Address.....: A2 2F BUILDING ENET NEW INDUSTRIAL PARK, DAFU INDUSTRIAL ZONE, GUANLAN, LONGHUA SHENZHEN, 518XXX China
Manufacturer's Name.....: SHENZHEN YUNJI INTELLIGENT TECHNOLOGY CO.,LTD
Address.....: A2 2F BUILDING ENET NEW INDUSTRIAL PARK, DAFU INDUSTRIAL ZONE, GUANLAN, LONGHUA SHENZHEN, 518XXX China
Product name.....: Tablet
Model and/or type reference.....: RT8
Family Model: RT8 S, RT8 Pro, RT8 Ultra, RT8 TITAN
Test sample number S231123027015
Standards.....: FCC CFR 47 Part 22H, Part 24E, Part 27
Test procedure.....: ANSI C63.26:2015
ANSI/TIA-603-E-2016

This device described above has been tested by NTEK, and the test results show that the equipment under test (EUT) is in compliance with the FCC requirements. And it is applicable only to the tested sample identified in the report.

This report shall not be reproduced except in full, without the written approval of NTEK, this document may be altered or revised by NTEK, personal only, and shall be noted in the revision of the document.

Date of Test
Date (s) of performance of tests 27 Nov. 2023 ~ 18 Dec, 2023
Date of Issue 19 Dec, 2023
Test Result..... Pass

Prepared By: Allen Liu (Project Engineer)

Reviewed By: Aaron Cheng (Supervisor)

Approved By: Alex Li (Manager)

TABLE OF CONTENTS

1. GENERAL INFORMATION	5
1.1 PRODUCT DESCRIPTION	5
1.2 RELATED SUBMITTAL(S) / GRANT (S)	6
1.3 TEST METHODOLOGY	6
1.4 TEST FACILITY	6
MEASUREMENT UNCERTAINTY	6
1.5 SPECIAL ACCESSORIES.....	6
1.6 WORST-CASE CONFIGURATION AND MODE.....	6
1.6 SUMMARY OF TEST RESULTS	7
2. SYSTEM TEST CONFIGURATION	9
2.1 EUT CONFIGURATION.....	9
2.2 EUT EXERCISE	9
2.3 CONFIGURATION OF EUT SYSTEM.....	9
2.4 TEST SETUP	10
3.TEST AND MEASUREMENT EQUIPMENT	11
4. OUTPUT POWER	13
4.1 OUTPUT POWER MEASUREMENT	13
6. BANDEDGE AND EMISSION MASK	16
7. OUT OF BAND EMISSIONS	17
7.1 MEASUREMENT METHOD	18
8. RADIATED MEASUREMENT	19
8.1. RADIATED POWER (ERP & EIRP).....	19
8.2 LTE BAND 2.....	20
8.3 LTE BAND 4.....	24
8.4 LTE BAND 5.....	28

8.5 LTE BAND 7.....	30
8.5 LTE BAND 12.....	32
8.6 LTE BAND 17.....	34
9. SPURIOUS RADIATION EMISSION	36
9.1 LTE BAND 2.....	38
9.2 LTE BAND 4.....	40
9.3 LTE BAND 5.....	42
9.4 LTE BAND 7.....	44
9.5 LTE BAND 12.....	46
9.6 LTE BAND 17.....	48
10. FREQUENCY STABILITY	50
10.1 LTE BAND 2.....	51
10.2 LTE BAND 4.....	53
10.3 LTE BAND 5.....	55
10.4 LTE BAND 7.....	57
10.5 LTE BAND 12.....	59
10.6 LTE BAND 17.....	61
11. PEAK-TO-AVERAGE RATIO.....	63
11.1 Description of the PAR Measurement.....	63
11.2 Measuring Instruments.....	63
11.3 Test Procedures.....	63
11.4 Test Setup.....	63

1. GENERAL INFORMATION

1.1 PRODUCT DESCRIPTION

A major technical description of EUT is described as following:

Product Designation:	Tablet
Trade Mark	OUKITEL
Model Name	RT8
Family Model	RT8 S, RT8 Pro, RT8 Ultra, RT8 TITAN
Model Difference	All models are the same circuit and RF module, except the model name.
FCC ID:	2ANMU-RT8
Frequency Bands:	U.S. Bands: <input checked="" type="checkbox"/> LTE FDD Band 2, 4, 5, 7, 12, 17
Frequency Range:	LTE FDD Band 2 Uplink: 1850MHz-1910MHz, Downlink: 1930MHz-1990MHz; LTE FDD Band 4 Uplink: 1710MHz-1755MHz, Downlink: 2110MHz-2155MHz; LTE FDD Band 5 Uplink: 824MHz-849MHz, Downlink: 869MHz-894MHz; LTE-FDD Band 7 Uplink: 2500MHz-2570MHz, Downlink: 2620MHz-2690MHz; LTE FDD Band 12 Uplink: 699MHz-716MHz, Downlink: 729MHz-746MHz; LTE FDD Band 17 Uplink: 704MHz-716MHz, Downlink: 734MHz-746MHz;
Type of Modulation:	QPSK/16QAM
Antenna:	PIFA Antenna
Antenna gain:	Band 2:2.2dBi, Band 4: 1.3dBi, Band 5: -1.05dBi, Band 7: 2.59dBi, Band 12: -1.35dBi, Band 17: -1.35dBi
Power Supply:	DC 3.87V/20000mAh from battery or DC 5V from Adapter.
Adapter:	Model: HJ-PD33W-US Input: 100-240V~50/60Hz 0.8A Output: 5.0V---3.0A OR 9.0V---3.0A OR 12.0V---2.75A 33.0W MAX
Extreme Vol. Limits:	DC 3.4V to DC 4.2V (Nominal DC 3.87V) (Note 1)
HW Version	P556_MAIN_PCB_V1.1
SW Version	OUKITEL_RT8_EEA_V01_20231121
** Note1: The High Voltage 4.2V and Low Voltage 3.4V was declared by manufacturer, The EUT couldn't be operate normally with higher or lower voltage.	

1.2 RELATED SUBMITTAL(S) / GRANT (S)

This submittal(s) (test report) is intended for **FCC ID: 2ANMU-RT8** filing to comply with the FCC Part 22H&24E &27.

1.3 TEST METHODOLOGY

The tests documented in this report were performed in accordance with ANSI/TIA-603-E-2016, FCC CFR 47 Part 2, Part 22, Part 24, Part 27, ANSI C63.26:2015.

1.4 TEST FACILITY

The test site used to collect the radiated data is located at:

ShenZhen NTEK Testing Technology Co., Ltd.

1&5/F, Building C, 1&2/F, Building E, Fenda Science Park, Sanwei Community, Hangcheng Street, Baoan District, Shenzhen ,Guangdong, China.

The test site is constructed and calibrated to meet the FCC requirements in documents ANSI C63.46:2015& ANSI C63.4: 2014.

FCC Registration No.:463705

IC Registration No.:9270A,

CNAS Registration No.:L5516

MEASUREMENT UNCERTAINTY

The reported uncertainty of measurement, where expended uncertainty U is based on a standard uncertainty multiplied by a coverage factor of k=2, providing a level of confidence of approximately 95 %.

No.	Item	Uncertainty
1	Measuring Uncertainty for a Level of Confidence of 95% (U = 2Uc(y))	2.5dB

1.5 SPECIAL ACCESSORIES

The battery and the charger, earphone supplied by the applicant were used as accessories and being tested with EUT intended for FCC grant together.

1.6 WORST-CASE CONFIGURATION AND MODE

The worst-case scenario for all measurements is based on the investigation results.

The device has LTE Bands of: Band 2, Band 4, Band 5, Band 7, Band 12, Band 17.

The RB Size was selected to measure for peak or average ERP and EIRP, which was based on the conducted power verification baseline data.

For the fundamental investigation of radiated emissions, the EUT is investigated for vertical and horizontal antenna orientations and X Y and Z orientations of the EUT alone. After the investigations the worst case was determined to be at X orientation for all LTE bands.

1.6 SUMMARY OF TEST RESULTS

FCC Part22, Subpart H/ FCC Part24, Subpart E, FCC Part27, Subpart L, KDB 971168 D01 Power Meas License Digital Systems v03			
FCC Rule	Test Item	Verdict	Remark
2.1046	Conducted Output Power	PASS	
22.913(d) 24.232(d) 27.50(d)(5) KDB 971168 D01 Clause 5.7	Peak-to-Average Ratio	PASS	
2.1049 22.917(b) 24.238(b) KDB 971168 D01 Clause 4.2	Occupied Bandwidth	PASS	
2.1051 22.917(a) 24.238(a) 27.53(c), (g), (h) KDB 971168 D01 Clause 6	Band Edge	PASS	
22.913(a)(2) 27.50(b)(10), (c)(10) KDB 971168 D01 Clause 5.6	Effective Radiated Power	PASS	
24.232(c) 27.50(h)(2), (d)(4) KDB 971168 D01 Clause 5.6	Equivalent Isotropic Radiated Power	PASS	
2.1053 22.917(a) 24.238(a) 27.53(c)(g)(h)(m) KDB 971168 D01 Clause 7	Field Strength of Spurious Radiation	PASS	
2.1055 22.355 24.235 27.54 KDB 971168 D01 Clause 9	Frequency Stability for Temperature & Voltage	PASS	

2.1051 22.917(a) 24.238(a) 27.53(c)(g)(h)(m) KDB 971168 D01 Clause 6	Conducted Emission	PASS	
--	--------------------	------	--

Remark:

1. "N/A" denotes test is not applicable in this Test Report.
2. All test items were verified and recorded according to the standards and without any deviation during the test.
3. No modifications are made to the EUT during all test items.

2. SYSTEM TEST CONFIGURATION

2.1 EUT CONFIGURATION

The EUT configuration for testing is installed on RF field strength measurement to meet the Commission's requirement and operating in a manner which intends to maximize its emission characteristics in a continuous normal application.

2.2 EUT EXERCISE

The Transmitter was operated in the maximum output power mode through Communication Tester. The TX frequency was fixed which was for the purpose of the measurements.

2.3 CONFIGURATION OF EUT SYSTEM

Table 2-1 Equipment Used in EUT System

Item	Equipment	Model No.	ID or Specification	Note
1	Tablet	RT8	FCC ID: 2ANMU-RT8	EUT

*Note: All the accessories have been used during the test.
the following "EUT" in setup diagram means EUT system.*

2.4 TEST SETUP

For Radiated Test Cases



For Conducted Output Power

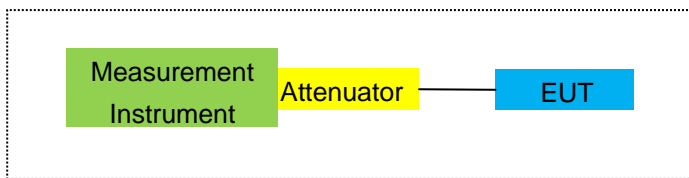

For Peak-to Average Ratio, Occupied Bandwidth, Conducted Band edge and Conducted Spurious Emission

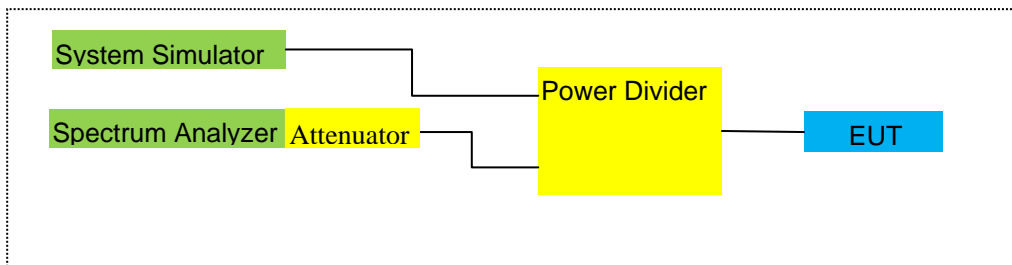

For Frequency Stability

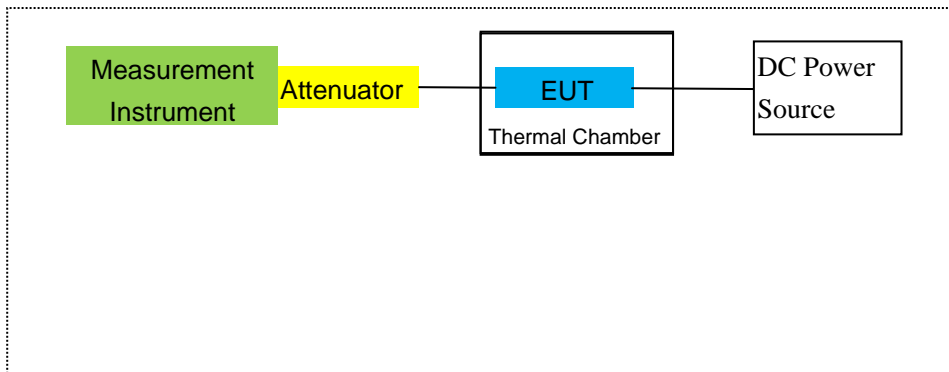

Note: EUT built-in battery-powered, the battery is fully-charged.

3. TEST AND MEASUREMENT EQUIPMENT

The following test and measurement equipment was utilized for the tests documented in this report:

Item	Kind of Equipment	Manufacturer	Type No.	Serial No.	Last calibration	Calibrated until	Calibration period
1	MXA Signal Analyzer	Agilent	N9020A	MY49100060	2023.05.29	2024.05.28	1 year
2	Test Receiver	R&S	ESPI	101318	2023.03.27	2024.03.26	1 year
3	Bilog Antenna	TESEQ	CBL6111D	31216	2023.03.27	2024.03.26	1 year
4	50Ω Coaxial Switch	Anritsu	MP59B	6200983705	2023.05.06	2026.05.05	3 year
5	Broadband Horn Antenna	SCHWARZBECK	BBHA 9120 D	2816	2023/1/12	2024/1/11	1 year
6	Broadband Horn Antenna	SCHWARZBECK	BBHA 9120 D	2817	2023/1/12	2024/1/11	1 year
7	Amplifier	EM	EM-30180	060538	2023.05.29	2024.05.28	1 year
8	Loop Antenna	ARA	PLA-1030/B	1029	2023.03.27	2024.03.26	1 year
9	Power Meter	R&S	NRVS	100696	2023.05.29	2024.05.28	1 year
10	Power Sensor	R&S	URV5-Z4	0395.1619.05	2023.03.27	2024.03.26	1 year
11	Test Cable	N/A	R-01	N/A	2022.06.17	2025.06.16	3 year
12	Test Cable	N/A	R-02	N/A	2022.06.17	2025.06.16	3 year
13	Test Cable	N/A	R-03	N/A	2022.06.17	2025.06.16	3 year
14	Test Receiver	R&S	ESCI	101160	2023.03.27	2024.03.26	1 year
15	LISN	R&S	ENV216	101313	2023.03.27	2024.03.26	1 year
16	LISN	EMCO	3816/2	00042990	2023.03.27	2024.03.26	1 year
17	50Ω Coaxial Switch	Anritsu	MP59B	6200264417	2023.03.27	2024.03.26	1 year
18	Passive Voltage Probe	R&S	ESH2-Z3	100196	2023.03.27	2024.03.26	1 year
19	Test Cable	N/A	C01	N/A	2023.05.06	2026.05.05	3 year
20	Test Cable	N/A	C02	N/A	2023.05.06	2026.05.05	3 year
21	Test Cable	N/A	C03	N/A	2023.05.06	2026.05.05	3 year
22	Attenuator	MCE	24-10-34	BN9258	2023.03.27	2024.03.26	1 year
23	Spectrum Analyzer	agilent	e4440a	us44300399	2023.03.27	2024.03.26	1 year
24	test receiver	R&S	ESCI	a0304218	2023.03.27	2024.03.26	1 year

25	Communication Tester	R&S	CMU200	A0304247	2023.05.29	2024.05.28	1 year
26	Thermal Chamber	Ten Billion	TTC-B3C	TBN-960502	2023.03.27	2024.03.26	1 year
27	DC Power Source	N/A	PS-6005D	2017040292 3	2023.05.06	2026.05.05	3 year
28	MXG Vector Signal Generator	Agilent	N5182A	MY47070317	2023.05.29	2024.05.28	1 year
29	Communication Tester	R&S	CMW500	148500	2023.05.29	2024.05.28	1 year
30	MXG Vector Signal Generator	Agilent	N5183B	MY57280984	2022/11/8	2023/11/7	1 year
31	Log-Periodic Antenna	SCHWARZBECK	VULB 9162	584	2023/1/11	2024/1/10	1 year
32	Log-Periodic Antenna	SCHWARZBECK	VULB 9162	586	2023/1/11	2024/1/10	1 year

Note: Each piece of equipment is scheduled for calibration once a year except the Test Cable& DC Power Source which is scheduled for calibration every 3 years.

4. OUTPUT POWER

4.1 OUTPUT POWER MEASUREMENT

LTE Measurement Procedure:

All LTE bands conducted power peak and average are obtained from the CMW500 telecommunication test set. The following tests were conducted according to the test requirements outlined in section 6.2 of the 3GPP TS36.101 specification.

UE Power Class: 3 (23 +/- 2dBm). The allowed Maximum Power Reduction (MPR) for the maximum output power due to higher order modulation and transmit bandwidth configuration (resource blocks) is specified in Table 6.2.3-1 of the 3GPP TS36.101.

Table 6.2.3-1: Maximum Power Reduction (MPR) for Power Class 3

Modulation	Channel bandwidth / Transmission bandwidth (RB)						MPR (dB)
	1.4 MHz	3.0 MHz	5 MHz	10 MHz	15 MHz	20 MHz	
QPSK	> 5	> 4	> 8	> 12	> 16	> 18	≤ 1
16 QAM	≤ 5	≤ 4	≤ 8	≤ 12	≤ 16	≤ 18	≤ 1
16 QAM	> 5	> 4	> 8	> 12	> 16	> 18	≤ 2

The allowed A-MPR values specified below in Table 6.2.4.-1 of 3GPP TS36.101 are in addition to the allowed MPR requirements. All the measurements below were performed with A-MPR disabled, by using Network Signaling Value of "NS_01".3

Table 6.2.4-1: Additional Maximum Power Reduction (A-MPR)

Network Signalling value	Requirements (sub-clause)	E-UTRA Band	Channel bandwidth (MHz)	Resources Blocks (N_{RB})	A-MPR (dB)
NS_01	6.6.2.1.1	Table 5.5-1	1.4, 3, 5, 10, 15, 20	Table 5.6-1	NA
NS_03	6.6.2.2.1	2, 4, 10, 23, 25, 35, 36	3	>5	≤ 1
			5	>6	≤ 1
			10	>6	≤ 1
			15	>8	≤ 1
			20	>10	≤ 1
NS_04	6.6.2.2.2	41	5	>6	≤ 1
			10, 15, 20	See Table 6.2.4-4	
NS_05	6.6.3.3.1	1	10, 15, 20	≥ 50	≤ 1
NS_06	6.6.2.2.3	12, 13, 14, 17	1.4, 3, 5, 10	Table 5.6-1	n/a
NS_07	6.6.2.2.3	13	10	Table 6.2.4-2	Table 6.2.4-2
	6.6.3.3.2				
NS_08	6.6.3.3.3	19	10, 15	> 44	≤ 3
NS_09	6.6.3.3.4	21	10, 15	> 40	≤ 1
				> 55	≤ 2
NS_10		20	15, 20	Table 6.2.4-3	Table 6.2.4-3
NS_11	6.6.2.2.1	23 ¹	1.4, 3, 5, 10	Table 6.2.4-5	Table 6.2.4-5
..					
NS_32	-	-	-	-	-

Note 1: Applies to the lower block of Band 23, i.e. a carrier placed in the 2000-2010 MHz region.

Test data reference attachment.

5. OCCUPIED BANDWIDTH

RULE PART(S)

FCC: §2.1049

LIMITS

For reporting purposes only

TEST PROCEDURE

The transmitter output was connected to a calibrated coaxial cable and coupler, the other end of which was connected to a spectrum analyzer. The occupied bandwidth was measured with the spectrum analyzer at the low, middle and high channel in each band. The -26dB bandwidth was also measured and recorded.

MODES TESTED

- LTE Band2
- LTE Band 4
- LTE Band 5
- LTE Band 7
- LTE Band 12
- LTE Band 17

RESULTS

PASS

Test data reference attachment.

6. BANDEDGE AND EMISSION MASK

RULE PART(S)

FCC: §2.1051, §22.917(a), §24.238(a), §27.53(c)(g)(h)(m)

FCC: §2.1046, §22.913, §24.232

LIMITS

The minimum permissible attenuation level of any spurious emission is $43 + \log_{10}(P[\text{Watts}])$, where P is the transmitter power in Watts.

The minimum permissible attenuation level for Band 7 is as following.

Per 27.53(g) for operations in the 698-746 MHz band, in the 100 kHz bands immediately outside and adjacent to the frequency block a resolution bandwidth of at least 30 kHz may be employed to demonstrate compliance with the out-of-band emissions limit.

Per 27.53(c.5) for operations in the 776-788 MHz band, in the 100 kHz bands immediately outside and adjacent to the frequency block a resolution bandwidth of at least 30 kHz may be employed to demonstrate compliance with the out-of-band emissions limit.

For all plots showing emissions in the 763 – 775MHz and 793 – 805MHz band, the FCC limit per 27.53(c.4) is $65 + 10\log_{10}(P) = -35\text{dBm}$ in a 6.25kHz bandwidth.

Per 27.53(m) for operations in the BRS/EBS bands, the attenuation factor shall be not less than $40 + 10 \log (P)$ dB on all frequencies between the channel edge and 5 megahertz from the channel edge, $43 + 10 \log (P)$ dB on all frequencies between 5 megahertz and X megahertz from the channel edge, and $55 + 10 \log (P)$ dB on all frequencies more than X megahertz from the channel edge, where X is the greater of 6 megahertz or the actual emission bandwidth.

TEST PROCEDURE

The transmitter output was connected to a CMW500Test Set and configured to operate at maximum power. The band edge emissions were measured at the required operating frequencies in each band on the Spectrum Analyzer.

For each band edge measurement:

Set the spectrum analyzer span to include the block edge frequency

Set a marker to point the corresponding band edge frequency in each test case.

Set display line

Set resolution bandwidth to at least 1% of emission bandwidth.

MODES TESTED

- LTE Band 2/4/5/7/12/17

RESULTS

Test data reference attachment.

Note: Both QPSK and 16QAM has been tested, the worst case is QPSK mode, the report just reported the worst case.

7. OUT OF BAND EMISSIONS

RULE PART(S)

FCC: §2.1051, §22.917(a), §24.238(a), §27.53(c)(g)(h)(m)

LIMITS

The minimum permissible attenuation level of any spurious emission is $43 + \log_{10}(P[\text{Watts}])$, where P is the transmitter power in Watts.

The minimum permissible attenuation level for Band 7 is as following.

Per 27.53(g) for operations in the 698-746 MHz band, in the 100 kHz bands immediately outside and adjacent to the frequency block a resolution bandwidth of at least 30 kHz may be employed to demonstrate compliance with the out-of-band emissions limit.

Per 27.53(c.5) for operations in the 776-788 MHz band, in the 100 kHz bands immediately outside and adjacent to the frequency block a resolution bandwidth of at least 30 kHz may be employed to demonstrate compliance with the out-of-band emissions limit.

For all plots showing emissions in the 763 – 775MHz and 793 – 805MHz band, the FCC limit per 27.53(c.4) is $65 + 10\log_{10}(P) = -35\text{dBm}$ in a 6.25kHz bandwidth.

Per 27.53(m) for operations in the BRS/EBS bands, the attenuation factor shall be not less than $40 + 10 \log (P)$ dB on all frequencies between the channel edge and 5 megahertz from the channel edge, $43 + 10 \log (P)$ dB on all frequencies between 5 megahertz and X megahertz from the channel edge, and $55 + 10 \log (P)$ dB on all frequencies more than X megahertz from the channel edge, where X is the greater of 6 megahertz or the actual emission bandwidth.

TEST PROCEDURE

The RF output of the transmitter was connected to a spectrum analyzer through a calibrated coaxial cable. Sufficient scans were taken to show the out-of-band Emissions, if any, up to 10th harmonic. Multiple sweeps were recorded in maximum hold mode using a peak detector to ensure that the worst-case emissions were caught.

For each out of band emissions measurement:

- Set display line
- Set RBW & VBW to 100 kHz for the measurement below 1 GHz, and 1 MHz for the measurement above 1 GHz.

MODES TESTED

- LTE Band2
- LTE Band 4
- LTE Band 5
- LTE Band 7
- LTE Band 12
- LTE Band 17

7.1 MEASUREMENT METHOD

The test set up and general procedure is similar to conducted peak output power test. Only different for setting the measurement configuration of the measuring instrument of Spectrum Analyzer.

Test data reference attachment.

Note: Both QPSK and 16QAM has been tested, the worst case is QPSK mode, the report just reported the worst case.

8. RADIATED MEASUREMENT

8.1. RADIATED POWER (ERP & EIRP)

RULE PART(S)

FCC: §2.1046, §22.913(a)(2), §24.232(c) and §27.50 (h)(2), (b)(10), (c)(10), (d)(4)

LIMITS:

22.913(a) (2)- The ERP of mobile transmitters and auxiliary test transmitters must not exceed 7 Watts.
24.232 (c) Mobile and portable stations are limited to 2 watts EIRP.
27.50 (c) (10) the following power and antenna height requirements apply to stations transmitting in the 698–746 MHz band, the portable stations (hand-held devices) are limited to 3 watts ERP.
27.50 (b)(10) Portable stations (hand-held devices) transmitting in the 746–757 MHz, 758–763 MHz, 776–793 MHz, and 805–806 MHz bands are limited to 3 watts ERP.
27.50 (d)(4) The following power and antenna height requirements apply to stations transmitting in the 1710–1755 MHz and 2110–2155 MHz bands: Fixed, mobile, and portable (hand-held) stations operating in the 1710–1755 MHz band are limited to 1 watt EIRP.
27.50 (h)(2) Mobile and other user stations in the 2500–2570 MHz and 2620–2690 MHz bands. Mobile stations are limited to 2.0 watts EIRP. All user stations are limited to 2.0 watts transmitter output power.

TEST PROCEDURE

ANSI/TIA-603-E Clause 2.2.17

KDB 971168 v02r01 RF power output using broadband peak and average power meter method.

KDB 971168 D01 Power Meas License Digital Systems v02r01, “Measurement Guidance for Certification of Licensed Digital Transmitters”

MODES TESTED

- LTE Band2
- LTE Band 4
- LTE Band 5
- LTE Band 7
- LTE Band 12
- LTE Band 17

RESULTS

Pass

8.2 LTE BAND 2

Radiated Power (EIRP) for Band 2									
Mode	RB/RB SIZE	Frequency	Result						Conclusion
			SG Level (dBm)	Cable Loss (dBm)	Antenna Factor (dB)	Max. EIRP Average (dBm)	Max. EIRP Average (mW)	Polarization Of Max. ERP	
1.4MHz Band QPSK	1/#Mid	1850.7	-2.81	3.76	28.24	21.67	146.893	Horizontal	Pass
		1880	-2.62	3.91	28.22	21.69	147.571	Horizontal	Pass
		1909.3	-2.53	3.93	28.20	21.74	149.279	Horizontal	Pass
3.0MHz Band QPSK	1/#Mid	1851.5	-2.87	3.77	28.23	21.59	144.212	Horizontal	Pass
		1880	-2.72	3.91	28.24	21.61	144.877	Horizontal	Pass
		1908.5	-2.59	3.94	28.25	21.72	148.594	Horizontal	Pass
5.0MHz Band QPSK	1/#Mid	1852.5	-2.76	3.77	28.31	21.78	150.661	Horizontal	Pass
		1880	-2.38	3.91	28.22	21.93	155.955	Horizontal	Pass
		1907.5	-2.31	3.94	28.20	21.95	156.675	Horizontal	Pass
10.0MHz Band QPSK	1/#Mid	1855	-2.62	3.79	28.33	21.92	155.597	Horizontal	Pass
		1880	-2.32	3.95	28.22	21.95	156.675	Horizontal	Pass
		1905	-2.21	3.97	28.19	22.01	158.855	Horizontal	Pass
15.0MHz Band QPSK	1/#Mid	1857.5	-2.58	3.79	28.34	21.97	157.398	Horizontal	Pass
		1880	-2.37	3.95	28.22	21.90	154.882	Horizontal	Pass
		1902.5	-2.23	3.97	28.18	21.98	157.761	Horizontal	Pass
20.0MHz Band QPSK	1/#Mid	1860	-2.57	3.81	28.35	21.97	157.398	Horizontal	Pass
		1880	-2.24	3.96	28.22	22.02	159.221	Horizontal	Pass
		1900	-2.18	4.00	28.16	21.98	157.761	Horizontal	Pass
1.4MHz Band QPSK	1/#Mid	1850.7	-3.69	3.76	28.24	20.79	119.950	Vertical	Pass
		1880	-3.88	3.91	28.22	20.43	110.408	Vertical	Pass
		1909.3	-3.13	3.93	28.20	21.14	130.017	Vertical	Pass
3.0MHz Band QPSK	1/#Mid	1851.5	-4.07	3.77	28.23	20.39	109.396	Vertical	Pass
		1880	-3.60	3.91	28.24	20.73	118.304	Vertical	Pass
		1908.5	-3.42	3.94	28.25	20.89	122.744	Vertical	Pass
5.0MHz Band QPSK	1/#Mid	1852.5	-3.21	3.77	28.31	21.33	135.831	Vertical	Pass
		1880	-3.59	3.91	28.22	20.72	118.032	Vertical	Pass
		1907.5	-3.44	3.94	28.20	20.82	120.781	Vertical	Pass
10.0MHz Band QPSK	1/#Mid	1855	-3.61	3.79	28.33	20.93	123.880	Vertical	Pass
		1880	-3.63	3.95	28.22	20.64	115.878	Vertical	Pass
		1905	-3.66	3.97	28.19	20.56	113.763	Vertical	Pass
15.0MHz Band	1/#Mid	1857.5	-3.39	3.79	28.34	21.16	130.617	Vertical	Pass
		1880	-3.60	3.95	28.22	20.67	116.681	Vertical	Pass

QPSK		1902.5	-3.05	3.97	28.18	21.16	130.617	Vertical	Pass
20.0MHz	1/#Mid	1860	-4.00	3.81	28.35	20.54	113.240	Vertical	Pass
Band		1880	-3.80	3.96	28.22	20.46	111.173	Vertical	Pass
QPSK		1900	-3.77	4.00	28.16	20.39	109.396	Vertical	Pass

Note:

SG Level= Signal generator output

Max. EIRP Average (dBm)= Factor Gain(dB) + SG Level (dBm)- Cable Loss(dBm)

Factor Gain(dB)=Antenna Gain(dB) + Amplifier Factor (dB)

Radiated Power (EIRP) for Band 2										
Mode	RB/RB SIZE	Frequency	Result					Polarization Of Max. ERP	Conclusion	
			SG Level (dBm)	Cable Loss (dBm)	Antenna Factor (dB)	Max. EIRP	Max. EIRP			
						Average (dBm)	Average			Average
							(mW)			
1.4MHz Band 16 QAM	1/#Mid	1850.7	-3.93	3.76	28.24	20.55	113.501	Horizontal	Pass	
		1880	-3.40	3.91	28.22	20.91	123.310	Horizontal	Pass	
		1909.3	-3.33	3.93	28.20	20.94	124.165	Horizontal	Pass	
3.0MHz Band 16 QAM	1/#Mid	1851.5	-3.43	3.77	28.23	21.03	126.765	Horizontal	Pass	
		1880	-3.51	3.91	28.24	20.82	120.781	Horizontal	Pass	
		1908.5	-3.72	3.94	28.25	20.59	114.551	Horizontal	Pass	
5.0MHz Band 16 QAM	1/#Mid	1852.5	-3.37	3.77	28.31	21.17	130.918	Horizontal	Pass	
		1880	-3.28	3.91	28.22	21.03	126.765	Horizontal	Pass	
		1907.5	-2.96	3.94	28.20	21.30	134.896	Horizontal	Pass	
10.0MHz Band 16 QAM	1/#Mid	1855	-3.42	3.79	28.33	21.12	129.420	Horizontal	Pass	
		1880	-3.41	3.95	28.22	20.86	121.899	Horizontal	Pass	
		1905	-2.88	3.97	28.19	21.34	136.144	Horizontal	Pass	
15.0MHz Band 16 QAM	1/#Mid	1857.5	-3.40	3.79	28.34	21.15	130.317	Horizontal	Pass	
		1880	-3.19	3.95	28.22	21.08	128.233	Horizontal	Pass	
		1902.5	-3.15	3.97	28.18	21.06	127.644	Horizontal	Pass	
20.0MHz Band 16 QAM	1/#Mid	1860	-3.29	3.81	28.35	21.25	133.352	Horizontal	Pass	
		1880	-2.99	3.96	28.22	21.27	133.968	Horizontal	Pass	
		1900	-2.81	4.00	28.16	21.35	136.458	Horizontal	Pass	
1.4MHz Band 16 QAM	1/#Mid	1850.7	-5.00	3.76	28.24	19.48	88.716	Vertical	Pass	
		1880	-4.14	3.91	28.22	20.17	103.992	Vertical	Pass	
		1909.3	-4.46	3.93	28.20	19.81	95.719	Vertical	Pass	
3.0MHz Band 16 QAM	1/#Mid	1851.5	-4.48	3.77	28.23	19.98	99.541	Vertical	Pass	
		1880	-4.17	3.91	28.24	20.16	103.753	Vertical	Pass	
		1908.5	-4.55	3.94	28.25	19.76	94.624	Vertical	Pass	
5.0MHz Band 16 QAM	1/#Mid	1852.5	-4.30	3.77	28.31	20.24	105.682	Vertical	Pass	
		1880	-4.02	3.91	28.22	20.29	106.905	Vertical	Pass	
		1907.5	-3.94	3.94	28.20	20.32	107.647	Vertical	Pass	
10.0MHz Band 16 QAM	1/#Mid	1855	-4.75	3.79	28.33	19.79	95.280	Vertical	Pass	
		1880	-4.83	3.95	28.22	19.44	87.902	Vertical	Pass	
		1905	-4.28	3.97	28.19	19.94	98.628	Vertical	Pass	
15.0MHz Band 16 QAM	1/#Mid	1857.5	-4.70	3.79	28.34	19.85	96.605	Vertical	Pass	
		1880	-4.28	3.95	28.22	19.99	99.770	Vertical	Pass	
		1902.5	-4.75	3.97	28.18	19.46	88.308	Vertical	Pass	

20.0MHz		1860	-4.33	3.81	28.35	20.21	104.954	Vertical	Pass
Band 16	1/#Mid	1880	-4.77	3.96	28.22	19.49	88.920	Vertical	Pass
QAM		1900	-4.27	4.00	28.16	19.89	97.499	Vertical	Pass

Note:

SG Level= Signal generator output

Max. EIRP Average (dBm)= Factor Gain (dB) + SG Level (dBm)- Cable Loss(dBm)

Factor Gain(dB)=Antenna Gain(dB) + Amplifier Factor (dB)

8.3 LTE BAND 4

Radiated Power (EIRP) for Band 4									
Mode	RB/RB SIZE	Frequency	Result						Conclusion
			SG Level	Cable Loss	Antenna Factor	Max. EIRP	Max. EIRP	Polarization	
			(dBm)	(dBm)	(dB)	Average	Average	Of Max. ERP	
						(dBm)	(mW)		
1.4MHz Band QPSK	1/#Mid	1710.7	-2.72	3.12	27.58	21.74	149.279	Horizontal	Pass
		1732.5	-2.71	3.27	27.61	21.63	145.546	Horizontal	Pass
		1754.3	-2.69	3.29	27.63	21.65	146.218	Horizontal	Pass
3.0MHz Band QPSK	1/#Mid	1711.5	-2.89	3.13	27.61	21.59	144.212	Horizontal	Pass
		1732.5	-2.81	3.27	27.61	21.53	142.233	Horizontal	Pass
		1753.5	-2.73	3.30	27.62	21.59	144.212	Horizontal	Pass
5.0MHz Band QPSK	1/#Mid	1712.5	-2.66	3.13	27.63	21.84	152.757	Horizontal	Pass
		1732.5	-2.56	3.27	27.61	21.78	150.661	Horizontal	Pass
		1752.5	-2.44	3.30	27.60	21.86	153.462	Horizontal	Pass
10.0MHz Band QPSK	1/#Mid	1715	-2.60	3.15	27.64	21.89	154.525	Horizontal	Pass
		1732.5	-2.37	3.31	27.61	21.93	155.955	Horizontal	Pass
		1750	-2.39	3.33	27.59	21.87	153.815	Horizontal	Pass
15.0MHz Band QPSK	1/#Mid	1717.5	-2.61	3.15	27.65	21.89	154.525	Horizontal	Pass
		1732.5	-2.45	3.31	27.61	21.85	153.109	Horizontal	Pass
		1747.5	-2.39	3.33	27.57	21.85	153.109	Horizontal	Pass
20.0MHz Band QPSK	1/#Mid	1720	-2.55	3.17	27.66	21.94	156.315	Horizontal	Pass
		1732.5	-2.38	3.32	27.61	21.91	155.239	Horizontal	Pass
		1745	-2.32	3.36	27.56	21.88	154.170	Horizontal	Pass
1.4MHz Band QPSK	1/#Mid	1710.7	-3.26	3.12	27.58	21.20	131.826	Vertical	Pass
		1732.5	-3.10	3.27	27.61	21.24	133.045	Vertical	Pass
		1754.3	-3.33	3.29	27.63	21.01	126.183	Vertical	Pass
3.0MHz Band QPSK	1/#Mid	1711.5	-3.77	3.13	27.61	20.71	117.761	Vertical	Pass
		1732.5	-3.51	3.27	27.61	20.83	121.060	Vertical	Pass
		1753.5	-3.21	3.30	27.62	21.11	129.122	Vertical	Pass
5.0MHz Band QPSK	1/#Mid	1712.5	-3.53	3.13	27.63	20.97	125.026	Vertical	Pass
		1732.5	-3.01	3.27	27.61	21.33	135.831	Vertical	Pass
		1752.5	-3.47	3.30	27.60	20.83	121.060	Vertical	Pass
10.0MHz Band QPSK	1/#Mid	1715	-3.98	3.15	27.64	20.51	112.460	Vertical	Pass
		1732.5	-3.02	3.31	27.61	21.28	134.276	Vertical	Pass
		1750	-3.73	3.33	27.59	20.53	112.980	Vertical	Pass

15.0MHz		1717.5	-4.02	3.15	27.65	20.48	111.686	Vertical	Pass
Band	1/#Mid	1732.5	-3.57	3.31	27.61	20.73	118.304	Vertical	Pass
QPSK		1747.5	-3.40	3.33	27.57	20.84	121.339	Vertical	Pass
20.0MHz		1720	-3.52	3.17	27.66	20.97	125.026	Vertical	Pass
Band	1/#Mid	1732.5	-2.99	3.32	27.61	21.30	134.896	Vertical	Pass
QPSK		1745	-3.19	3.36	27.56	21.01	126.183	Vertical	Pass

Note:

SG Level= Signal generator output

Max. EIRP Average (dBm)= Factor Gain (dB)+ SG Level (dBm)- Cable Loss(dBm)

Factor Gain(dB)=Antenna Gain(dB) + Amplifier Factor (dB)

Radiated Power (EIRP) for Band 4									
Mode	RB/RB SIZE	Frequency	Result						Conclusion
			SG Level	Cable Loss (dBm)	Antenna Factor (dB)	Max. EIRP	Max. EIRP	Polarization Of Max. ERP	
			(dBm)			Average	Average		
						(dBm)	(mW)		
1.4MHz Band 16 QAM	1/#Mid	1710.7	-3.53	3.12	27.58	20.93	123.880	Horizontal	Pass
		1732.5	-3.38	3.27	27.61	20.96	124.738	Horizontal	Pass
		1754.3	-3.38	3.29	27.63	20.96	124.738	Horizontal	Pass
3.0MHz Band 16 QAM	1/#Mid	1711.5	-3.47	3.13	27.61	21.01	126.183	Horizontal	Pass
		1732.5	-3.60	3.27	27.61	20.74	118.577	Horizontal	Pass
		1753.5	-3.82	3.30	27.62	20.50	112.202	Horizontal	Pass
5.0MHz Band 16 QAM	1/#Mid	1712.5	-3.30	3.13	27.63	21.20	131.826	Horizontal	Pass
		1732.5	-3.26	3.27	27.61	21.08	128.233	Horizontal	Pass
		1752.5	-2.95	3.30	27.60	21.35	136.458	Horizontal	Pass
10.0MHz Band 16 QAM	1/#Mid	1715	-3.37	3.15	27.64	21.12	129.420	Horizontal	Pass
		1732.5	-3.56	3.31	27.61	20.74	118.577	Horizontal	Pass
		1750	-2.94	3.33	27.59	21.32	135.519	Horizontal	Pass
15.0MHz Band 16 QAM	1/#Mid	1717.5	-3.17	3.15	27.65	21.33	135.831	Horizontal	Pass
		1732.5	-3.23	3.31	27.61	21.07	127.938	Horizontal	Pass
		1747.5	-3.25	3.33	27.57	20.99	125.603	Horizontal	Pass
20.0MHz Band 16 QAM	1/#Mid	1720	-3.12	3.17	27.66	21.37	137.088	Horizontal	Pass
		1732.5	-3.13	3.32	27.61	21.16	130.617	Horizontal	Pass
		1745	-2.94	3.36	27.56	21.26	133.660	Horizontal	Pass
1.4MHz Band 16 QAM	1/#Mid	1710.7	-4.47	3.12	27.58	19.99	99.770	Vertical	Pass
		1732.5	-4.37	3.27	27.61	19.97	99.312	Vertical	Pass
		1754.3	-4.82	3.29	27.63	19.52	89.536	Vertical	Pass
3.0MHz Band 16 QAM	1/#Mid	1711.5	-4.82	3.13	27.61	19.66	92.470	Vertical	Pass
		1732.5	-4.86	3.27	27.61	19.48	88.716	Vertical	Pass
		1753.5	-3.98	3.30	27.62	20.34	108.143	Vertical	Pass
5.0MHz Band 16 QAM	1/#Mid	1712.5	-4.53	3.13	27.63	19.97	99.312	Vertical	Pass
		1732.5	-4.57	3.27	27.61	19.77	94.842	Vertical	Pass
		1752.5	-4.77	3.30	27.60	19.53	89.743	Vertical	Pass
10.0MHz Band 16 QAM	1/#Mid	1715	-4.59	3.15	27.64	19.90	97.724	Vertical	Pass
		1732.5	-4.11	3.31	27.61	20.19	104.472	Vertical	Pass
		1750	-4.10	3.33	27.59	20.16	103.753	Vertical	Pass
15.0MHz Band 16 QAM	1/#Mid	1717.5	-4.86	3.15	27.65	19.64	92.045	Vertical	Pass
		1732.5	-4.74	3.31	27.61	19.56	90.365	Vertical	Pass
		1747.5	-3.92	3.33	27.57	20.32	107.647	Vertical	Pass

20.0MHz		1720	-4.20	3.17	27.66	20.29	106.905	Vertical	Pass
Band 16	1/#Mid	1732.5	-4.60	3.32	27.61	19.69	93.111	Vertical	Pass
QAM		1745	-3.87	3.36	27.56	20.33	107.895	Vertical	Pass

Note:

SG Level= Signal generator output

Max. EIRP Average (dBm)= Factor Gain (dB)+ SG Level (dBm)- Cable Loss(dBm)

Factor Gain(dB)=Antenna Gain(dB) + Amplifier Factor (dB)

8.4 LTE BAND 5

Radiated Power (ERP) for Band 5											
Mode	RB/RB SIZE	Frequency	Result							Polarization Of Max. ERP	Conclusion
			SG Level	Cable Loss	Antenna Factor	Correction	Max. EIRP	Max. EIRP			
			(dBm)	(dBm)	(dB)	(dB)	Average	Average			
							(dBm)	(mW)			
1.4MHz	Band QPSK	824.7	6.58	2.01	19.68	2.15	22.10	162.181	Horizontal	Pass	
		836.5	6.46	2.01	19.77	2.15	22.07	161.065	Horizontal	Pass	
		848.3	6.26	2.02	19.82	2.15	21.91	155.239	Horizontal	Pass	
3.0MHz	Band QPSK	825.5	6.35	2.01	19.70	2.15	21.89	154.525	Horizontal	Pass	
		836.5	6.25	2.01	19.77	2.15	21.86	153.462	Horizontal	Pass	
		847.5	6.12	2.02	19.81	2.15	21.76	149.968	Horizontal	Pass	
5.0MHz	Band QPSK	826.5	6.63	2.01	19.71	2.15	22.18	165.196	Horizontal	Pass	
		836.5	6.51	2.01	19.77	2.15	22.12	162.930	Horizontal	Pass	
		846.5	6.35	2.02	19.79	2.15	21.97	157.398	Horizontal	Pass	
10.0MHz	Band QPSK	829	6.65	2.01	19.73	2.15	22.22	166.725	Horizontal	Pass	
		836.5	6.60	2.01	19.77	2.15	22.21	166.341	Horizontal	Pass	
		844	6.50	2.02	19.78	2.15	22.11	162.555	Horizontal	Pass	
1.4MHz	Band QPSK	824.7	5.08	2.01	19.68	2.15	20.60	114.815	Vertical	Pass	
		836.5	5.14	2.01	19.77	2.15	20.75	118.850	Vertical	Pass	
		848.3	5.42	2.02	19.82	2.15	21.07	127.938	Vertical	Pass	
3.0MHz	Band QPSK	825.5	5.79	2.01	19.70	2.15	21.33	135.831	Vertical	Pass	
		836.5	5.07	2.01	19.77	2.15	20.68	116.950	Vertical	Pass	
		847.5	5.39	2.02	19.81	2.15	21.03	126.765	Vertical	Pass	
5.0MHz	Band QPSK	826.5	4.98	2.01	19.71	2.15	20.53	112.980	Vertical	Pass	
		836.5	4.97	2.01	19.77	2.15	20.58	114.288	Vertical	Pass	
		846.5	5.14	2.02	19.79	2.15	20.76	119.124	Vertical	Pass	
10.0MHz	Band QPSK	829	5.75	2.01	19.73	2.15	21.32	135.519	Vertical	Pass	
		836.5	5.09	2.01	19.77	2.15	20.70	117.490	Vertical	Pass	
		844	4.78	2.02	19.78	2.15	20.39	109.396	Vertical	Pass	

Radiated Power (ERP) for Band 5

Radiated Power (ERP) for Band 5											
Mode	RB/RB SIZE	Frequency	Result							Polarization Of Max. ERP	Conclusion
			SG Level	Cable Loss (dBm)	Antenna Factor (dB)	Correction (dB)	Max. EIRP	Max. EIRP			
			(dBm)				Average	Average			
							(dBm)	(mW)			
1.4MHz Band 16 QAM	3/#Mid	824.7	5.73	2.01	19.68	2.15	21.25	133.352	Horizontal	Pass	
		836.5	5.66	2.01	19.77	2.15	21.27	133.968	Horizontal	Pass	
		848.3	5.50	2.02	19.82	2.15	21.15	130.317	Horizontal	Pass	
3.0MHz Band 16 QAM	1/#Mid	825.5	5.81	2.01	19.70	2.15	21.35	136.458	Horizontal	Pass	
		836.5	5.52	2.01	19.77	2.15	21.13	129.718	Horizontal	Pass	
		847.5	5.00	2.02	19.81	2.15	20.64	115.878	Horizontal	Pass	
5.0MHz Band 16 QAM	1/#Mid	826.5	6.13	2.01	19.71	2.15	21.68	147.231	Horizontal	Pass	
		836.5	5.90	2.01	19.77	2.15	21.51	141.579	Horizontal	Pass	
		846.5	5.65	2.02	19.79	2.15	21.27	133.968	Horizontal	Pass	
10.0MHz Band 16 QAM	1/#Mid	829	6.13	2.01	19.73	2.15	21.70	147.911	Horizontal	Pass	
		836.5	5.85	2.01	19.77	2.15	21.46	139.959	Horizontal	Pass	
		844	5.39	2.02	19.78	2.15	21.00	125.893	Horizontal	Pass	
1.4MHz Band 16 QAM	1/#Mid	824.7	4.88	2.01	19.68	2.15	20.40	109.648	Vertical	Pass	
		836.5	4.16	2.01	19.77	2.15	19.77	94.842	Vertical	Pass	
		848.3	5.03	2.02	19.82	2.15	20.68	116.950	Vertical	Pass	
3.0MHz Band 16 QAM	1/#Mid	825.5	4.16	2.01	19.70	2.15	19.70	93.325	Vertical	Pass	
		836.5	4.85	2.01	19.77	2.15	20.46	111.173	Vertical	Pass	
		847.5	4.87	2.02	19.81	2.15	20.51	112.460	Vertical	Pass	
5.0MHz Band 16 QAM	1/#Mid	826.5	4.35	2.01	19.71	2.15	19.90	97.724	Vertical	Pass	
		836.5	5.72	2.01	19.77	2.15	21.33	135.831	Vertical	Pass	
		846.5	3.81	2.02	19.79	2.15	19.43	87.700	Vertical	Pass	
10.0MHz Band 16 QAM	1/#Mid	829	4.87	2.01	19.73	2.15	20.44	110.662	Vertical	Pass	
		836.5	5.43	2.01	19.77	2.15	21.04	127.057	Vertical	Pass	
		844	5.36	2.02	19.78	2.15	20.97	125.026	Vertical	Pass	

Note:

ERP=EIRP-2.15

SG Level= Signal generator output

Max. EIRP Average (dBm)= Factor Gain (dB)+ SG Level (dBm)- Cable Loss(dBm)

Factor Gain(dB)=Antenna Gain(dB) + Amplifier Factor (dB)

8.5 LTE BAND 7

Radiated Power (EIRP) for Band 7									
Mode	RB/RB SIZE	Frequency	Result						Conclusion
			SG Level	Cable Loss	Antenna Factor	Max. EIRP	Max. EIRP	Polarization	
			(dBm)	(dBm)	(dB)	Average	Average	Of Max. ERP	
						(dBm)	(mW)		
5.0MHz Band QPSK	1/#Mid	2502.5	-1.00	4.54	27.75	22.21	166.341	Horizontal	Pass
		2535	-0.83	4.69	27.72	22.20	165.959	Horizontal	Pass
		2567.5	-0.76	4.71	27.71	22.24	167.494	Horizontal	Pass
10.0MHz Band QPSK	1/#Mid	2505	-0.93	4.55	27.76	22.28	169.044	Horizontal	Pass
		2535	-0.74	4.69	27.72	22.29	169.434	Horizontal	Pass
		2565	-0.66	4.72	27.70	22.32	170.608	Horizontal	Pass
15.0MHz Band QPSK	1/#Mid	2507.5	-0.94	4.55	27.77	22.28	169.044	Horizontal	Pass
		2535	-0.80	4.69	27.72	22.23	167.109	Horizontal	Pass
		2562.5	-0.70	4.72	27.69	22.27	168.655	Horizontal	Pass
20.0MHz Band QPSK	1/#Mid	2510	-0.88	4.57	27.78	22.33	171.002	Horizontal	Pass
		2535	-0.70	4.73	27.72	22.29	169.434	Horizontal	Pass
		2560	-0.66	4.75	27.68	22.27	168.655	Horizontal	Pass
5.0MHz Band QPSK	1/#Mid	2502.5	-2.77	4.54	27.75	20.44	110.662	Vertical	Pass
		2535	-2.35	4.69	27.72	20.68	116.950	Vertical	Pass
		2567.5	-1.93	4.71	27.71	21.07	127.938	Vertical	Pass
10.0MHz Band QPSK	1/#Mid	2505	-1.95	4.55	27.76	21.26	133.660	Vertical	Pass
		2535	-2.63	4.69	27.72	20.40	109.648	Vertical	Pass
		2565	-2.32	4.72	27.70	20.66	116.413	Vertical	Pass
15.0MHz Band QPSK	1/#Mid	2507.5	-2.67	4.55	27.77	20.55	113.501	Vertical	Pass
		2535	-1.77	4.69	27.72	21.26	133.660	Vertical	Pass
		2562.5	-2.31	4.72	27.69	20.66	116.413	Vertical	Pass
20.0MHz Band QPSK	1/#Mid	2510	-2.71	4.57	27.78	20.50	112.202	Vertical	Pass
		2535	-1.82	4.73	27.72	21.17	130.918	Vertical	Pass
		2560	-1.89	4.75	27.68	21.04	127.057	Vertical	Pass

Radiated Power (EIRP) for Band 7									
Mode	RB/RB SIZE	Frequency	Result						Conclusion
			SG Level	Cable Loss (dBm)	Antenna Factor (dB)	Max. EIRP	Max. EIRP	Polarization Of Max. ERP	
			(dBm)			Average	Average		
						(dBm)	(mW)		
5.0MHz Band 16 QAM	1/#Mid	2502.5	-1.69	4.54	27.75	21.52	141.906	Horizontal	Pass
		2535	-1.38	4.69	27.72	21.65	146.218	Horizontal	Pass
		2567.5	-1.46	4.71	27.71	21.54	142.561	Horizontal	Pass
10.0MHz Band 16 QAM	1/#Mid	2505	-1.58	4.55	27.76	21.63	145.546	Horizontal	Pass
		2535	-1.59	4.69	27.72	21.44	139.316	Horizontal	Pass
		2565	-1.86	4.72	27.70	21.12	129.420	Horizontal	Pass
15.0MHz Band 16 QAM	1/#Mid	2507.5	-1.76	4.55	27.77	21.46	139.959	Horizontal	Pass
		2535	-1.73	4.69	27.72	21.30	134.896	Horizontal	Pass
		2562.5	-1.34	4.72	27.69	21.63	145.546	Horizontal	Pass
20.0MHz Band 16 QAM	1/#Mid	2510	-1.64	4.57	27.78	21.57	143.549	Horizontal	Pass
		2535	-1.31	4.73	27.72	21.68	147.231	Horizontal	Pass
		2560	-1.41	4.75	27.68	21.52	141.906	Horizontal	Pass
5.0MHz Band 16 QAM	1/#Mid	2502.5	-2.32	4.54	27.75	20.89	122.744	Vertical	Pass
		2535	-3.57	4.69	27.72	19.46	88.308	Vertical	Pass
		2567.5	-1.93	4.71	27.71	21.07	127.938	Vertical	Pass
10.0MHz Band 16 QAM	1/#Mid	2505	-3.66	4.55	27.76	19.55	90.157	Vertical	Pass
		2535	-3.61	4.69	27.72	19.42	87.498	Vertical	Pass
		2565	-1.97	4.72	27.70	21.01	126.183	Vertical	Pass
15.0MHz Band 16 QAM	1/#Mid	2507.5	-3.79	4.55	27.77	19.43	87.700	Vertical	Pass
		2535	-2.34	4.69	27.72	20.69	117.220	Vertical	Pass
		2562.5	-2.21	4.72	27.69	20.76	119.124	Vertical	Pass
20.0MHz Band 16 QAM	1/#Mid	2510	-2.61	4.57	27.78	20.60	114.815	Vertical	Pass
		2535	-2.47	4.73	27.72	20.52	112.720	Vertical	Pass
		2560	-2.17	4.75	27.68	20.76	119.124	Vertical	Pass

Note:

SG Level= Signal generator output

Max. EIRP Average (dBm)= Factor Gain (dB)+ SG Level (dBm)- Cable Loss(dBm)

Factor Gain(dB)=Antenna Gain(dB) + Amplifier Factor (dB)

8.5 LTE BAND 12

Radiated Power (ERP) for Band 12											
Mode	RB/RB SIZE	Frequency	Result							Polarization Of Max. ERP	Conclusion
			SG	Cable	Antenna	Correction	Max. EIRP	Max.			
			Level	Loss	Factor		EIRP				
			(dBm)	(dBm)	(dB)		Average	Average			
			(dB)	(dBm)	(mW)						
1.4MHz Band QPSK	1/#Mid	699.7	6.95	1.91	19.21	2.15	22.10	162.181	Vertical	Pass	
		707.5	6.87	1.91	19.26	2.15	22.07	161.065	Vertical	Pass	
		715.3	6.65	1.93	19.34	2.15	21.91	155.239	Vertical	Pass	
3.0MHz Band QPSK	1/#Mid	700.5	6.74	1.91	19.21	2.15	21.89	154.525	Vertical	Pass	
		707.5	6.66	1.91	19.26	2.15	21.86	153.462	Vertical	Pass	
		714.5	6.50	1.93	19.34	2.15	21.76	149.968	Vertical	Pass	
5.0MHz Band QPSK	1/#Mid	701.5	7.01	1.91	19.23	2.15	22.18	165.196	Vertical	Pass	
		707.5	6.92	1.91	19.26	2.15	22.12	162.930	Vertical	Pass	
		713.5	6.71	1.92	19.33	2.15	21.97	157.398	Vertical	Pass	
10.0MHz Band QPSK	1/#Mid	704	7.03	1.91	19.25	2.15	22.22	166.725	Vertical	Pass	
		707.5	7.01	1.91	19.26	2.15	22.21	166.341	Vertical	Pass	
		711	6.86	1.92	19.32	2.15	22.11	162.555	Vertical	Pass	
1.4MHz Band QPSK	1/#Mid	699.7	5.32	1.91	19.21	2.15	20.47	111.429	Horizontal	Pass	
		707.5	5.55	1.91	19.26	2.15	20.75	118.850	Horizontal	Pass	
		715.3	5.55	1.93	19.34	2.15	20.81	120.504	Horizontal	Pass	
3.0MHz Band QPSK	1/#Mid	700.5	5.47	1.91	19.21	2.15	20.62	115.345	Horizontal	Pass	
		707.5	6.11	1.91	19.26	2.15	21.31	135.207	Horizontal	Pass	
		714.5	6.11	1.93	19.34	2.15	21.37	137.088	Horizontal	Pass	
5.0MHz Band QPSK	1/#Mid	701.5	5.57	1.91	19.23	2.15	20.74	118.577	Horizontal	Pass	
		707.5	5.87	1.91	19.26	2.15	21.07	127.938	Horizontal	Pass	
		713.5	5.58	1.92	19.33	2.15	20.84	121.339	Horizontal	Pass	
10.0MHz Band QPSK	1/#Mid	704	5.42	1.91	19.25	2.15	20.61	115.080	Horizontal	Pass	
		707.5	5.47	1.91	19.26	2.15	20.67	116.681	Horizontal	Pass	
		711	6.10	1.92	19.32	2.15	21.35	136.458	Horizontal	Pass	

Radiated Power (ERP) for Band 12										
Mode	RB/RB SIZE	Frequency	Result							Conclusion
			SG Level	Cable Loss	Antenna Factor	Correction	Max. EIRP	Max. EIRP	Polarization	
			(dBm)	(dBm)	(dB)	(dB)	Average	Average	Of Max. ERP	
							(dBm)	(mW)		
1.4MHz Band 16 QAM	1/#Mid	699.7	6.83	1.91	19.21	2.15	21.98	157.761	Vertical	Pass
		707.5	6.75	1.91	19.26	2.15	21.95	156.675	Vertical	Pass
		715.3	6.53	1.93	19.34	2.15	21.79	151.008	Vertical	Pass
3.0MHz Band 16 QAM	1/#Mid	700.5	6.62	1.91	19.21	2.15	21.77	150.314	Vertical	Pass
		707.5	6.54	1.91	19.26	2.15	21.74	149.279	Vertical	Pass
		714.5	6.38	1.93	19.34	2.15	21.64	145.881	Vertical	Pass
5.0MHz Band 16 QAM	1/#Mid	701.5	6.89	1.91	19.23	2.15	22.06	160.694	Vertical	Pass
		707.5	6.80	1.91	19.26	2.15	22.00	158.489	Vertical	Pass
		713.5	6.59	1.92	19.33	2.15	21.85	153.109	Vertical	Pass
10.0MHz Band 16 QAM	1/#Mid	704	6.91	1.91	19.25	2.15	22.10	162.181	Vertical	Pass
		707.5	6.89	1.91	19.26	2.15	22.09	161.808	Vertical	Pass
		711	6.74	1.92	19.32	2.15	21.99	158.125	Vertical	Pass
1.4MHz Band 16 QAM	1/#Mid	699.7	6.07	1.91	19.21	2.15	21.22	132.434	Horizontal	Pass
		707.5	5.46	1.91	19.26	2.15	20.66	116.413	Horizontal	Pass
		715.3	5.68	1.93	19.34	2.15	20.94	124.165	Horizontal	Pass
3.0MHz Band 16 QAM	1/#Mid	700.5	5.23	1.91	19.21	2.15	20.38	109.144	Horizontal	Pass
		707.5	5.71	1.91	19.26	2.15	20.91	123.310	Horizontal	Pass
		714.5	5.71	1.93	19.34	2.15	20.97	125.026	Horizontal	Pass
5.0MHz Band 16 QAM	1/#Mid	701.5	5.21	1.91	19.23	2.15	20.38	109.144	Horizontal	Pass
		707.5	5.83	1.91	19.26	2.15	21.03	126.765	Horizontal	Pass
		713.5	5.21	1.92	19.33	2.15	20.47	111.429	Horizontal	Pass
10.0MHz Band 16 QAM	1/#Mid	704	5.18	1.91	19.25	2.15	20.37	108.893	Horizontal	Pass
		707.5	6.03	1.91	19.26	2.15	21.23	132.739	Horizontal	Pass
		711	5.86	1.92	19.32	2.15	21.11	129.122	Horizontal	Pass

Note:

ERP=EIRP-2.15

SG Level= Signal generator output

Max. EIRP Average (dBm)= Factor Gain (dB)+ SG Level (dBm)- Cable Loss(dBm)

Factor Gain(dB)=Antenna Gain(dB) + Amplifier Factor (dB)

8.6 LTE BAND 17

Radiated Power (ERP) for Band 17											
Mode	RB/RB SIZE	Frequency	Result							Polarization Of Max. ERP	Conclusion
			SG Level	Cable Loss	Antenna Factor	Correction	Max. EIRP	Max. EIRP			
			(dBm)	(dBm)	(dB)		Average	Average			
							(dBm)	(mW)			
5.0MHz Band QPSK	1/#Mid	706.5	6.22	1.91	19.23	2.15	21.39	137.721	Vertical	Pass	
		710	6.08	1.91	19.26	2.15	21.28	134.276	Vertical	Pass	
		713.5	5.98	1.92	19.33	2.15	21.24	133.045	Vertical	Pass	
10.0MHz Band QPSK	1/#Mid	709	6.23	1.91	19.25	2.15	21.42	138.676	Vertical	Pass	
		710	6.18	1.91	19.26	2.15	21.38	137.404	Vertical	Pass	
		711	6.14	1.92	19.32	2.15	21.39	137.721	Vertical	Pass	
5.0MHz Band QPSK	1/#Mid	706.5	5.82	1.91	19.23	2.15	20.99	125.603	Horizontal	Pass	
		710	4.09	1.91	19.26	2.15	19.29	84.918	Horizontal	Pass	
		713.5	5.02	1.92	19.33	2.15	20.28	106.660	Horizontal	Pass	
10.0MHz Band QPSK	1/#Mid	709	5.93	1.91	19.25	2.15	21.12	129.420	Horizontal	Pass	
		710	4.69	1.91	19.26	2.15	19.89	97.499	Horizontal	Pass	
		711	5.17	1.92	19.32	2.15	20.42	110.154	Horizontal	Pass	

Radiated Power (ERP) for Band 17											
Mode	RB/RB SIZE	Frequency	Result							Polarization Of Max. ERP	Conclusion
			SG Level	Cable Loss	Antenna Factor	Correction	Max. EIRP	Max. EIRP	Of Max. ERP		
			(dBm)	(dBm)	(dB)		Average	Average			
							(dB)	(dBm)			
5.0MHz	1/#Mid	706.5	5.57	1.91	19.23	2.15	20.74	118.577	Vertical	Pass	
Band 16		710	5.48	1.91	19.26	2.15	20.68	116.950	Vertical	Pass	
QAM		713.5	5.28	1.92	19.33	2.15	20.54	113.240	Vertical	Pass	
10.0MHz	1/#Mid	709	5.11	1.91	19.25	2.15	20.30	107.152	Vertical	Pass	
Band 16		710	5.64	1.91	19.26	2.15	20.84	121.339	Vertical	Pass	
QAM		711	5.37	1.92	19.32	2.15	20.62	115.345	Vertical	Pass	
5.0MHz	1/#Mid	706.5	4.57	1.91	19.23	2.15	19.74	94.189	Horizontal	Pass	
Band 16		710	4.37	1.91	19.26	2.15	19.57	90.573	Horizontal	Pass	
QAM		713.5	3.98	1.92	19.33	2.15	19.24	83.946	Horizontal	Pass	
10.0MHz	1/#Mid	709	4.90	1.91	19.25	2.15	20.09	102.094	Horizontal	Pass	
Band 16		710	4.86	1.91	19.26	2.15	20.06	101.391	Horizontal	Pass	
QAM		711	4.80	1.92	19.32	2.15	20.05	101.158	Horizontal	Pass	

Note:

ERP=EIRP-2.15

SG Level= Signal generator output

Max. EIRP Average (dBm)= Factor Gain (dB)+ SG Level (dBm)- Cable Loss(dBm)

Factor Gain(dB)=Antenna Gain(dB) + Amplifier Factor (dB)

9. SPURIOUS RADIATION EMISSION

RULE PART(S)

FCC: §2.1051, §22.917(a), §24.238(a), §27.53(c)(g)(h)(m)

LIMIT

For Band 7, the minimum permissible attenuation level of any spurious emission is $55 + \log_{10}(P)$ [Watts].

The minimum permissible attenuation level of any spurious emission is $43 + \log_{10}(P)$ [Watts], where P is the transmitter power in Watts.

TEST PROCEDURE

For Cellular equipment - Compliance with these rules is based on the use of measurement instrumentation employing a resolution bandwidth of 100 kHz or greater. In the 1 MHz bands immediately outside and adjacent to the frequency block a resolution bandwidth of at least one percent of the emission bandwidth of the fundamental emission of the transmitter may be employed. A narrower resolution bandwidth is permitted in all cases to improve measurement accuracy provided the measured power is integrated over the full required measurement bandwidth (i.e. 100 kHz or 1 percent of emission bandwidth, as specified). The emission bandwidth is defined as the width of the signal between two points, one below the carrier center frequency and one above the carrier center frequency, outside of which all emissions are attenuated at least 26 dB below the transmitter power.

For PCS equipment - Compliance with these rules is based on the use of measurement instrumentation employing a resolution bandwidth of 1 MHz or greater. However, in the 1 MHz bands immediately outside and adjacent to the frequency block a resolution bandwidth of at least one percent of the emission bandwidth of the fundamental emission of the transmitter may be employed. A narrower resolution bandwidth is permitted in all cases to improve measurement accuracy provided the measured power is integrated over the full required measurement bandwidth (i.e. 1 MHz or 1 percent of emission bandwidth, as specified). The emission bandwidth is defined as the width of the signal between two points, one below the carrier center frequency and one above the carrier center frequency, outside of which all emissions are attenuated at least 26 dB below the transmitter power.

The unwanted emission power shall be measured with a resolution bandwidth of at least 1% of the occupied bandwidth in the 1 MHz band immediately outside and adjacent to the channel edge of the equipment. Beyond the 1 MHz band immediately outside the channel edge of the equipment, a resolution bandwidth of 1 MHz shall be employed. A narrower resolution bandwidth is allowed to be used provided that the measured power is integrated over the full required measurement bandwidth of 1 MHz or 1% of the occupied bandwidth as applicable.

The power of any unwanted emissions measured from the channel edge of the equipment shall be attenuated below the transmitter power, P (dBW), as follows:

- a. for base station and subscriber equipment, other than mobile subscriber equipment, the attenuation shall not be less than $43 + 10 \text{ Log}_{10}(p)$, dB; and
- b. for mobile subscriber equipment, the attenuation shall not be less than $43 + 10 \text{ Log}_{10}(p)$, dB at the channel edges and $55 + 10 \text{ Log}_{10}(p)$ at 5.5 MHz away and beyond the channel edges where p in (a) and (b) is the transmitter power measured in watts.

MODES TESTED

- LTE Band2
LTE Band 4
- LTE Band 5
LTE Band 7
LTE Band 12
LTE Band 17

RESULTS

PASS

9.1 LTE BAND 2

QPSK EIRP POWER FOR LTE BAND 2 (1.4MHZ BANDWIDTH)

Test Results for Low Channel 1850.7MHz							
Frequency(MHz)	SG Level(dBm)	Cable Loss(dB)	Antenna Factor(dB)	Absolute Level(dBm)	Limit (dBm)	Margin(dBm)	Polarity
3701.4	-51.52	4.04	33.51	-22.05	-13	-9.05	Horizontal
3701.4	-50.32	4.04	33.51	-20.85	-13	-7.85	Vertical
5552.1	-53.77	5.24	35.84	-23.17	-13	-10.17	Vertical
5552.1	-49.22	5.24	35.84	-18.62	-13	-5.62	Horizontal
185.7	-34.98	1.43	16.02	-20.39	-13	-7.39	Vertical
335.9	-36.51	1.30	17.99	-19.82	-13	-6.82	Horizontal
Test Results for Mid Channel 1880MHz							
3760.0	-52.07	4.04	33.56	-22.55	-13	-9.55	Horizontal
3760.0	-48.75	4.04	33.56	-19.23	-13	-6.23	Vertical
5640.0	-49.53	5.24	35.91	-18.86	-13	-5.86	Vertical
5640.0	-51.88	5.24	35.91	-21.21	-13	-8.21	Horizontal
207.7	-42.15	1.62	16.97	-26.80	-13	-13.80	Vertical
460.0	-37.46	1.74	15.98	-23.23	-13	-10.23	Horizontal
Test Results for High Channel 1909.3MHz							
3818.6	-48.12	4.04	34.00	-18.16	-13	-5.16	Horizontal
3818.6	-52.02	4.04	34.00	-22.06	-13	-9.06	Vertical
5727.9	-52.77	5.24	36.04	-21.97	-13	-8.97	Vertical
5727.9	-50.72	5.24	36.04	-19.92	-13	-6.92	Horizontal
200.9	-41.48	1.42	17.29	-25.61	-13	-12.61	Vertical
352.4	-41.66	1.50	17.90	-25.25	-13	-12.25	Horizontal

QPSK EIRP POWER FOR LTE BAND 2 (20.0MHZ BANDWIDTH)

Test Results for Low Channel 1860MHz							
Frequency(MHz)	SG Level(dBm)	Cable Loss(dB)	Antenna Factor(dB)	Absolute Level(dBm)	Limit (dBm)	Margin(dBm)	Polarity
3720.0	-53.80	4.07	33.54	-24.33	-13	-11.33	Horizontal
3720.0	-49.27	4.07	33.54	-19.80	-13	-6.80	Vertical
5580.0	-54.50	5.28	35.86	-23.92	-13	-10.92	Vertical
5580.0	-52.68	5.28	35.86	-22.10	-13	-9.10	Horizontal
209.1	-44.92	1.58	16.89	-29.60	-13	-16.60	Vertical
344.0	-43.58	1.76	17.26	-28.08	-13	-15.08	Horizontal
Test Results for Mid Channel 1880MHz							
3760.0	-52.43	4.04	33.56	-22.91	-13	-9.91	Horizontal
3760.0	-53.30	4.04	33.56	-23.78	-13	-10.78	Vertical
5640.0	-55.10	5.24	35.91	-24.43	-13	-11.43	Vertical
5640.0	-49.40	5.24	35.91	-18.73	-13	-5.73	Horizontal
177.7	-34.15	1.46	16.27	-19.34	-13	-6.34	Vertical
303.7	-35.05	1.59	15.15	-21.49	-13	-8.49	Horizontal
Test Results for High Channel 1900MHz							
3800.0	-48.63	4.04	34.00	-18.67	-13	-5.67	Horizontal
3800.0	-52.30	4.04	34.00	-22.34	-13	-9.34	Vertical
5700.0	-51.93	5.24	36.04	-21.13	-13	-8.13	Vertical
5700.0	-49.32	5.24	36.04	-18.52	-13	-5.52	Horizontal
211.2	-53.60	1.36	17.39	-37.56	-13	-24.56	Vertical
362.7	-41.02	1.66	15.39	-27.29	-13	-14.29	Horizontal

9.2 LTE BAND 4

QPSK EIRP POWER FOR LTE BAND 4 (1.4MHZ BANDWIDTH)

Test Results for Low Channel 1710.7MHz							
Frequency(MHz)	SG Level(dBm)	Cable Loss(dB)	Antenna Factor(dB)	Absolute Level(dBm)	Limit (dBm)	Margin(dBm)	Polarity
3421.4	-53.29	4.02	29.80	-27.51	-13	-14.51	Horizontal
3421.4	-48.86	4.02	29.80	-23.08	-13	-10.08	Vertical
5132.1	-52.30	5.24	35.84	-21.70	-13	-8.70	Vertical
5132.1	-49.07	5.24	35.84	-18.47	-13	-5.47	Horizontal
189.6	-39.00	1.68	16.04	-24.64	-13	-11.64	Vertical
299.4	-37.08	1.78	17.74	-21.12	-13	-8.12	Horizontal
Test Results for Mid Channel 1732.5MHz							
3465.0	-49.53	4.03	30.00	-23.56	-13	-10.56	Horizontal
3465.0	-46.92	4.03	30.00	-20.95	-13	-7.95	Vertical
5197.5	-53.06	5.25	35.86	-22.45	-13	-9.45	Vertical
5197.5	-50.32	5.25	35.86	-19.71	-13	-6.71	Horizontal
176.4	-39.24	1.72	17.69	-23.27	-13	-10.27	Vertical
324.5	-42.56	1.62	16.02	-28.15	-13	-15.15	Horizontal
Test Results for High Channel 1754.3MHz							
3508.6	-45.76	4.05	30.01	-19.80	-13	-6.80	Horizontal
3508.6	-51.63	4.05	30.01	-25.67	-13	-12.67	Vertical
5262.9	-54.30	5.26	35.86	-23.70	-13	-10.70	Vertical
5262.9	-50.61	5.26	35.86	-20.01	-13	-7.01	Horizontal
209.9	-38.88	1.80	16.69	-23.99	-13	-10.99	Vertical
441.7	-38.00	1.75	16.66	-23.10	-13	-10.10	Horizontal

QPSK EIRP POWER FOR LTE BAND 4 (20.0MHZ BANDWIDTH)

Test Results for Low Channel 1720MHz							
Frequency(MHz)	SG Level(dBm)	Cable Loss(dB)	Antenna Factor(dB)	Absolute Level(dBm)	Limit (dBm)	Margin(dBm)	Polarity
3440.0	-53.67	4.02	29.80	-27.89	-13	-14.89	Horizontal
3440.0	-47.15	4.02	29.80	-21.37	-13	-8.37	Vertical
5160.0	-52.60	5.24	35.84	-22.00	-13	-9.00	Vertical
5160.0	-53.23	5.24	35.84	-22.63	-13	-9.63	Horizontal
196.5	-43.68	1.57	17.26	-27.99	-13	-14.99	Vertical
337.2	-43.60	1.78	16.35	-29.03	-13	-16.03	Horizontal
Test Results for Mid Channel 1732.5MHz							
3465.0	-51.92	4.03	30.00	-25.95	-13	-12.95	Horizontal
3465.0	-48.51	4.03	30.00	-22.54	-13	-9.54	Vertical
5197.5	-55.30	5.25	35.86	-24.69	-13	-11.69	Vertical
5197.5	-51.83	5.25	35.86	-21.22	-13	-8.22	Horizontal
176.7	-44.97	1.44	17.95	-28.46	-13	-15.46	Vertical
384.5	-43.29	1.65	16.09	-28.85	-13	-15.85	Horizontal
Test Results for High Channel 1745MHz							
3490.0	-49.11	2.91	27.68	-24.34	-13	-11.34	Horizontal
3490.0	-46.27	2.91	27.68	-21.50	-13	-8.50	Vertical
5235.0	-48.69	5.26	35.86	-18.09	-13	-5.09	Vertical
5235.0	-50.80	5.26	35.86	-20.20	-13	-7.20	Horizontal
196.7	-36.29	1.61	16.85	-21.05	-13	-8.05	Vertical
244.0	-40.76	1.61	15.19	-27.18	-13	-14.18	Horizontal

9.3 LTE BAND 5

QPSK EIRP POWER FOR LTE BAND 5 (1.4MHZ BANDWIDTH)

Test Results for Low Channel 824.7MHz							
Frequency(MHz)	SG Level(dBm)	Cable Loss(dB)	Antenna Factor(dB)	Absolute Level(dBm)	Limit (dBm)	Margin(dBm)	Polarity
1649.4	-52.72	2.78	27.50	-28.00	-13	-15.00	Horizontal
1649.4	-53.96	2.78	27.50	-29.24	-13	-16.24	Vertical
2474.1	-48.32	2.90	27.80	-23.42	-13	-10.42	Vertical
2474.1	-49.67	2.90	27.80	-24.77	-13	-11.77	Horizontal
179.4	-39.46	1.76	17.59	-23.63	-13	-10.63	Vertical
428.9	-34.58	1.63	15.87	-20.34	-13	-7.34	Horizontal
Test Results For Mid Channel 836.5MHz							
1673.0	-48.32	2.80	27.48	-23.64	-13	-10.64	Horizontal
1673.0	-51.36	2.80	27.48	-26.68	-13	-13.68	Vertical
2509.5	-50.73	2.91	27.70	-25.94	-13	-12.94	Vertical
2509.5	-50.37	2.91	27.70	-25.58	-13	-12.58	Horizontal
192.9	-37.30	1.61	15.68	-23.23	-13	-10.23	Vertical
407.9	-43.62	1.59	17.52	-27.70	-13	-14.70	Horizontal
Test Results for High Channel 848.3MHz							
1696.6	-50.59	2.82	27.43	-25.98	-13	-12.98	Horizontal
1696.6	-53.52	2.82	27.43	-28.91	-13	-15.91	Vertical
2544.9	-52.95	2.92	27.74	-28.13	-13	-15.13	Vertical
2544.9	-50.57	2.92	27.74	-25.75	-13	-12.75	Horizontal
180.5	-38.95	1.69	16.67	-23.96	-13	-10.96	Vertical
294.7	-44.40	1.70	17.18	-28.92	-13	-15.92	Horizontal

QPSK EIRP POWER FOR LTE BAND 5 (10MHZ BANDWIDTH)

Test Results for Low Channel 829MHz							
Frequency(MHz)	SG Level(dBm)	Cable Loss(dB)	Antenna Factor(dB)	Absolute Level(dBm)	Limit (dBm)	Margin(dBm)	Polarity
1658.0	-51.25	2.78	27.50	-26.53	-13	-13.53	Horizontal
1658.0	-48.59	2.78	27.50	-23.87	-13	-10.87	Vertical
2487.0	-48.47	2.90	27.80	-23.57	-13	-10.57	Vertical
2487.0	-53.20	2.90	27.80	-28.30	-13	-15.30	Horizontal
182.6	-41.91	1.71	15.57	-28.05	-13	-15.05	Vertical
360.1	-35.33	1.34	16.40	-20.27	-13	-7.27	Horizontal
Test Results for Mid Channel 836.5MHz							
1673.0	-51.26	2.80	27.48	-26.58	-13	-13.58	Horizontal
1673.0	-50.09	2.80	27.48	-25.41	-13	-12.41	Vertical
2509.5	-48.45	2.91	27.70	-23.66	-13	-10.66	Vertical
2509.5	-49.79	2.91	27.70	-25.00	-13	-12.00	Horizontal
203.1	-38.61	1.44	17.04	-23.01	-13	-10.01	Vertical
307.5	-38.12	1.76	17.62	-22.26	-13	-9.26	Horizontal
Test Results for High Channel 844MHz							
1688.0	-48.76	2.82	27.43	-24.15	-13	-11.15	Horizontal
1688.0	-50.94	2.82	27.43	-26.33	-13	-13.33	Vertical
2532.0	-51.28	2.92	27.74	-26.46	-13	-13.46	Vertical
2532.0	-53.89	2.92	27.74	-29.07	-13	-16.07	Horizontal
183.7	-39.99	1.74	17.70	-24.03	-13	-11.03	Vertical
248.8	-34.57	1.41	17.46	-18.51	-13	-5.51	Horizontal

9.4 LTE BAND 7

QPSK EIRP POWER FOR LTE BAND 7 (5.0MHZ BANDWIDTH)

Test Results for Low Channel 2502.5MHz							
Frequency(MHz)	SG Level(dBm)	Cable Loss(dB)	Antenna Factor(dB)	Absolute Level(dBm)	Limit (dBm)	Margin(dBm)	Polarity
5005.0	-62.46	5.23	35.81	-31.88	-25	-6.88	Horizontal
5005.0	-61.11	5.23	35.81	-30.53	-25	-5.53	Vertical
7507.5	-64.20	5.67	36.85	-33.02	-25	-8.02	Vertical
7507.5	-60.39	5.67	36.85	-29.21	-25	-4.21	Horizontal
201.8	-45.64	1.73	17.97	-29.40	-25	-4.40	Vertical
316.5	-54.01	1.38	15.11	-40.28	-25	-15.28	Horizontal
Test Results for Mid Channel 2535MHz							
5070.0	-62.12	5.23	35.82	-31.53	-25	-6.53	Horizontal
5070.0	-63.84	5.23	35.82	-33.25	-25	-8.25	Vertical
7605.0	-61.85	5.67	36.85	-30.67	-25	-5.67	Vertical
7605.0	-63.06	5.67	36.85	-31.88	-25	-6.88	Horizontal
188.4	-47.53	1.77	16.17	-33.12	-25	-8.12	Vertical
416.3	-51.10	1.63	15.21	-37.52	-25	-12.52	Horizontal
Test Results for High Channel 2567.5MHz							
5135.0	-60.35	5.24	35.83	-29.76	-25	-4.76	Horizontal
5135.0	-59.31	5.24	35.83	-28.72	-25	-3.72	Vertical
7702.5	-63.62	5.68	36.87	-32.43	-25	-7.43	Vertical
7702.5	-62.14	5.68	36.87	-30.95	-25	-5.95	Horizontal
192.7	-44.84	1.58	17.56	-28.86	-25	-3.86	Vertical
316.7	-49.62	1.45	16.58	-34.49	-25	-9.49	Horizontal

QPSK EIRP POWER FOR LTE BAND 7 (20.0MHZ BANDWIDTH)

Test Results for Low Channel 2510MHz							
Frequency(MHz)	SG Level(dBm)	Cable Loss(dB)	Antenna Factor(dB)	Absolute Level(dBm)	Limit (dBm)	Margin(dBm)	Polarity
5020.0	-60.57	5.23	35.82	-29.98	-25	-4.98	Horizontal
5020.0	-59.37	5.23	35.82	-28.78	-25	-3.78	Vertical
7530.0	-61.82	5.67	36.86	-30.63	-25	-5.63	Vertical
7530.0	-63.06	5.67	36.86	-31.87	-25	-6.87	Horizontal
183.7	-48.79	1.63	15.76	-34.66	-25	-9.66	Vertical
372.3	-53.81	1.71	15.44	-40.08	-25	-15.08	Horizontal
Test Results for Mid Channel 2535MHz							
5070.0	-62.77	5.23	35.82	-32.18	-25	-7.18	Horizontal
5070.0	-60.71	5.23	35.82	-30.12	-25	-5.12	Vertical
7605.0	-64.05	5.67	36.85	-32.87	-25	-7.87	Vertical
7605.0	-60.97	5.67	36.85	-29.79	-25	-4.79	Horizontal
199.3	-52.39	1.79	16.84	-37.33	-25	-12.33	Vertical
365.6	-51.45	1.71	17.64	-35.52	-25	-10.52	Horizontal
Test Results for High Channel 2560MHz							
5120.0	-64.07	5.24	35.83	-33.48	-25	-8.48	Horizontal
5120.0	-61.06	5.24	35.83	-30.47	-25	-5.47	Vertical
7680.0	-62.75	5.70	36.88	-31.57	-25	-6.57	Vertical
7680.0	-64.30	5.70	36.88	-33.12	-25	-8.12	Horizontal
191.6	-44.03	1.79	16.84	-28.97	-25	-3.97	Vertical
402.7	-45.21	1.71	17.64	-29.28	-25	-4.28	Horizontal

9.5 LTE BAND 12

QPSK EIRP POWER FOR LTE BAND 12 (1.4MHZ BANDWIDTH)

Test Results for Low Channel 699.7MHz							
Frequency(MHz)	SG Level(dBm)	Cable Loss(dB)	Antenna Factor(dB)	Absolute Level(dBm)	Limit (dBm)	Margin(dBm)	Polarity
1399.4	-46.42	2.60	27.20	-21.82	-13	-8.82	Horizontal
1399.4	-53.79	2.60	27.20	-29.19	-13	-16.19	Vertical
2099.1	-46.97	2.85	27.54	-22.28	-13	-9.28	Vertical
2099.1	-50.46	2.85	27.54	-25.77	-13	-12.77	Horizontal
186.8	-42.82	1.49	17.78	-26.53	-13	-13.53	Vertical
340.7	-40.37	1.36	17.33	-24.40	-13	-11.40	Horizontal
Test Results For Mid Channel 707.5MHz							
1415.0	-47.13	2.61	27.28	-22.46	-13	-9.46	Horizontal
1415.0	-45.89	2.61	27.28	-21.22	-13	-8.22	Vertical
2122.5	-46.32	2.87	27.59	-21.60	-13	-8.60	Vertical
2122.5	-50.88	2.87	27.59	-26.16	-13	-13.16	Horizontal
186.8	-35.79	1.73	15.74	-21.78	-13	-8.78	Vertical
306.8	-42.16	1.62	15.79	-27.99	-13	-14.99	Horizontal
Test Results for High Channel 715.3MHz							
1430.6	-44.32	2.63	27.28	-19.67	-13	-6.67	Horizontal
1430.6	-47.28	2.63	27.28	-22.63	-13	-9.63	Vertical
2145.9	-46.43	2.88	27.60	-21.71	-13	-8.71	Vertical
2145.9	-50.36	2.88	27.60	-25.64	-13	-12.64	Horizontal
183.8	-39.36	1.61	18.00	-22.97	-13	-9.97	Vertical
259.8	-38.40	1.45	15.49	-24.37	-13	-11.37	Horizontal

QPSK EIRP POWER FOR LTE BAND 12 (10MHZ BANDWIDTH)

Test Results for Low Channel 704MHz							
Frequency(MHz)	SG Level(dBm)	Cable Loss(dB)	Antenna Factor(dB)	Absolute Level(dBm)	Limit (dBm)	Margin(dBm)	Polarity
1408.0	-44.50	2.61	27.26	-19.85	-13	-6.85	Horizontal
1408.0	-46.46	2.61	27.26	-21.81	-13	-8.81	Vertical
2112.0	-47.63	2.87	27.58	-22.92	-13	-9.92	Vertical
2112.0	-52.04	2.87	27.58	-27.33	-13	-14.33	Horizontal
190.1	-35.00	1.31	16.97	-19.34	-13	-6.34	Vertical
342.9	-42.68	1.65	16.70	-27.63	-13	-14.63	Horizontal
Test Results for Mid Channel 707.5MHz							
1415.0	-46.76	2.61	27.28	-22.09	-13	-9.09	Horizontal
1415.0	-52.92	2.61	27.28	-28.25	-13	-15.25	Vertical
2122.5	-52.38	2.87	27.59	-27.66	-13	-14.66	Vertical
2122.5	-53.83	2.87	27.59	-29.11	-13	-16.11	Horizontal
202.5	-36.45	1.72	17.99	-20.18	-13	-7.18	Vertical
251.8	-39.09	1.73	17.94	-22.88	-13	-9.88	Horizontal
Test Results for High Channel 711MHz							
1422.0	-51.62	2.62	27.28	-26.96	-13	-13.96	Horizontal
1422.0	-44.91	2.62	27.28	-20.25	-13	-7.25	Vertical
2133.0	-49.66	2.87	27.60	-24.93	-13	-11.93	Vertical
2133.0	-52.11	2.87	27.60	-27.38	-13	-14.38	Horizontal
197.1	-39.79	1.58	15.93	-25.44	-13	-12.44	Vertical
272.5	-43.44	1.36	15.59	-29.21	-13	-16.21	Horizontal

9.6 LTE BAND 17

QPSK EIRP POWER FOR LTE BAND 17 (5MHZ BANDWIDTH)

Test Results for Low Channel 706.5MHz							
Frequency(MHz)	SG Level(dBm)	Cable Loss(dB)	Antenna Factor(dB)	Absolute Level(dBm)	Limit (dBm)	Margin(dBm)	Polarity
1413.0	-47.58	2.61	27.28	-22.91	-13	-9.91	Horizontal
1413.0	-50.52	2.61	27.28	-25.85	-13	-12.85	Vertical
2119.5	-51.69	2.87	27.59	-26.97	-13	-13.97	Vertical
2119.5	-52.44	2.87	27.59	-27.72	-13	-14.72	Horizontal
208.9	-34.07	1.71	16.15	-19.63	-13	-6.63	Vertical
274.6	-42.84	1.41	17.32	-26.93	-13	-13.93	Horizontal
Test Results For Mid Channel 710MHz							
1420.0	-51.68	2.62	27.30	-27.00	-13	-14.00	Horizontal
1420.0	-46.04	2.62	27.30	-21.36	-13	-8.36	Vertical
2130.0	-50.09	2.87	27.62	-25.34	-13	-12.34	Vertical
2130.0	-51.54	2.87	27.62	-26.79	-13	-13.79	Horizontal
208.7	-34.47	1.42	15.25	-20.65	-13	-7.65	Vertical
291.2	-44.06	1.36	17.19	-28.23	-13	-15.23	Horizontal
Test Results for High Channel 713.5MHz							
1427.0	-45.62	2.66	27.28	-21.00	-13	-8.00	Horizontal
1427.0	-49.84	2.66	27.28	-25.22	-13	-12.22	Vertical
2140.5	-53.16	2.88	27.60	-28.44	-13	-15.44	Vertical
2140.5	-51.08	2.88	27.60	-26.36	-13	-13.36	Horizontal
201.6	-40.62	1.32	17.29	-24.65	-13	-11.65	Vertical
411.1	-39.59	1.72	16.89	-24.42	-13	-11.42	Horizontal

QPSK EIRP POWER FOR LTE BAND 17 (10MHZ BANDWIDTH)

Test Results for Low Channel 709MHz							
Frequency(MHz)	SG Level(dBm)	Cable Loss(dB)	Antenna Factor(dB)	Absolute Level(dBm)	Limit (dBm)	Margin(dBm)	Polarity
1418.0	-48.20	2.62	27.30	-23.52	-13	-10.52	Horizontal
1418.0	-53.22	2.62	27.30	-28.54	-13	-15.54	Vertical
2127.0	-50.58	2.87	27.62	-25.83	-13	-12.83	Vertical
2127.0	-51.30	2.87	27.62	-26.55	-13	-13.55	Horizontal
195.6	-42.63	1.35	16.91	-27.07	-13	-14.07	Vertical
410.6	-42.35	1.62	16.31	-27.66	-13	-14.66	Horizontal
Test Results for Mid Channel 710MHz							
1420.0	-53.35	2.62	27.30	-28.67	-13	-15.67	Horizontal
1420.0	-53.16	2.62	27.30	-28.48	-13	-15.48	Vertical
2130.0	-51.88	2.87	27.62	-27.13	-13	-14.13	Vertical
2130.0	-52.25	2.87	27.62	-27.50	-13	-14.50	Horizontal
195.1	-39.65	1.51	17.14	-24.02	-13	-11.02	Vertical
420.5	-34.56	1.77	16.88	-19.45	-13	-6.45	Horizontal
Test Results for High Channel 711MHz							
1422.0	-52.67	2.62	27.30	-27.99	-13	-14.99	Horizontal
1422.0	-47.26	2.62	27.30	-22.58	-13	-9.58	Vertical
2133.0	-53.93	2.87	27.62	-29.18	-13	-16.18	Vertical
2133.0	-52.48	2.87	27.62	-27.73	-13	-14.73	Horizontal
198.3	-39.10	1.78	15.95	-24.93	-13	-11.93	Vertical
400.5	-43.32	1.34	17.95	-26.72	-13	-13.72	Horizontal

10. FREQUENCY STABILITY

RULE PART(S)

FCC: §2.1055, §22.355, §24.235, §27.54

LIMITS

§22.355 - The carrier frequency shall not depart from the reference frequency in excess of ± 2.5 ppm for mobile stations.

§24.235 - The frequency stability shall be sufficient to ensure that the fundamental emission stays within the authorized frequency block.

TEST PROCEDURE

Use CMW 500 with Frequency Error measurement capability.

- Temp. = -30° to $+50^{\circ}\text{C}$
- Voltage = low voltage, DC 3.4V, Normal, DC3.87V and High voltage, DC 4.2V.

Frequency Stability vs Temperature:

The EUT is placed inside a temperature chamber. The temperature is set to -30°C and allowed to stabilize. After sufficient soak time, the transmitting frequency error is measured. The temperature is increased by 10 degrees, allowed to stabilize and soak, and then the measurement is repeated. This is repeated until $+50^{\circ}\text{C}$ is reached.

Frequency Stability vs Voltage:

The peak frequency error is recorded (worst-case).

MODES TESTED

- LTE Band2
LTE Band 4
- LTE Band5
LTE Band 7
LTE Band 12
LTE Band 17

RESULTS

See the following pages.

10.1 LTE BAND 2

QPSK, (20MHz BANDWIDTH)

Frequency error vs. Voltage

Voltage [Vdc]	Frequency [MHz]	Frequency* Error[Hz]	Frequency Error[ppm]	Limit [ppm]
BAND 2 QPSK, (CH 18900 RB size 100 RB Offset 0 20MHz BANDWIDTH)				
3.4	1880	12.6	0.006706	2.5
3.87	1880	13.4	0.007119	2.5
4.2	1880	13.3	0.007056	2.5

Frequency error vs. Temperature

Temperature [° C]	Frequency [MHz]	Frequency* Error[Hz]	Frequency Error[ppm]	Limit [ppm]
BAND 2 QPSK, (CH 18900 RB size 100 RB Offset 0 20MHz BANDWIDTH)				
Normal (25C)	1880	12.8	0.006817	2.5
Extreme (50C)	1880	11.1	0.005910	2.5
Extreme (40C)	1880	13.3	0.007069	2.5
Extreme (30C)	1880	13.8	0.007356	2.5
Extreme (10C)	1880	14.3	0.007591	2.5
Extreme (0C)	1880	11.6	0.006197	2.5
Extreme (-10C)	1880	12.6	0.006693	2.5
Extreme (-20C)	1880	14.1	0.007525	2.5
Extreme (-30C)	1880	15.0	0.007964	2.5

16QAM, (20MHz BANDWIDTH)

Frequency error vs. Voltage

Voltage [Vdc]	Frequency [MHz]	Frequency* Error[Hz]	Frequency Error[ppm]	Limit [ppm]
BAND 2 16QAM, (CH 18900 RB size 100 RB Offset 0 20MHz BANDWIDTH)				
3.4	1880	9.9	0.005244	2.5
3.87	1880	8.7	0.004614	2.5
4.2	1880	7.7	0.004089	2.5

Frequency error vs. Temperature

Temperature [° C]	Frequency [MHz]	Frequency* Error[Hz]	Frequency Error[ppm]	Limit [ppm]
BAND 2 16QAM, (CH 18900 RB size 100 RB Offset 0 20MHz BANDWIDTH)				
Normal (25C)	1880	9.5	0.005030	2.5
Extreme (50C)	1880	9.2	0.004881	2.5
Extreme (40C)	1880	8.1	0.004288	2.5
Extreme (30C)	1880	8.6	0.004583	2.5
Extreme (10C)	1880	8.4	0.004476	2.5
Extreme (0C)	1880	8.3	0.004395	2.5
Extreme (-10C)	1880	8.5	0.004545	2.5
Extreme (-20C)	1880	9.1	0.004852	2.5
Extreme (-30C)	1880	8.2	0.004356	2.5

*Note: Frequency error measurements were made by using the build-in capability of the Wireless Communication Test Set.

10.2 LTE BAND 4

QPSK, (10MHz BANDWIDTH)

Frequency error vs. Voltage

Voltage [Vdc]	Frequency [MHz]	Frequency* Error[Hz]	Frequency Error[ppm]	Limit [ppm]
BAND 4 QPSK, (CH 20175 RB size 100 RB Offset 0 20MHz BANDWIDTH)				
3.4	1732.5	8.7	0.005041	2.5
3.87	1732.5	8.4	0.004870	2.5
4.2	1732.5	8.0	0.004616	2.5

Frequency error vs. Temperature

Temperature [°C]	Frequency [MHz]	Frequency* Error[Hz]	Frequency Error[ppm]	Limit [ppm]
BAND 4 QPSK, (CH 20175 RB size 100 RB Offset 0 20MHz BANDWIDTH)				
Normal (25C)	1732.5	8.3	0.004790	2.5
Extreme (50C)	1732.5	8.8	0.005074	2.5
Extreme (40C)	1732.5	7.3	0.004205	2.5
Extreme (30C)	1732.5	5.8	0.003320	2.5
Extreme (10C)	1732.5	7.4	0.004272	2.5
Extreme (0C)	1732.5	9.5	0.005490	2.5
Extreme (-10C)	1732.5	8.8	0.005055	2.5
Extreme (-20C)	1732.5	6.6	0.003783	2.5
Extreme (-30C)	1732.5	8.6	0.004944	2.5

16QAM, (20MHz BANDWIDTH)

Frequency error vs. Voltage

Voltage [Vdc]	Frequency [MHz]	Frequency* Error[Hz]	Frequency Error[ppm]	Limit [ppm]
BAND 4 16QAM, (CH 20175 RB size 100 RB Offset 0 20MHz BANDWIDTH)				
3.4	1732.5	9.8	0.005676	2.5
3.87	1732.5	8.8	0.005058	2.5
4.2	1732.5	8.1	0.004680	2.5

Frequency error vs. Temperature

Temperature [°C]	Frequency [MHz]	Frequency* Error[Hz]	Frequency Error[ppm]	Limit [ppm]
BAND 4 16QAM, (CH 20175 RB size 100 RB Offset 0 20MHz BANDWIDTH)				
Normal (25C)	1732.5	10.2	0.005879	2.5
Extreme (50C)	1732.5	9.4	0.005411	2.5
Extreme (40C)	1732.5	7.8	0.004503	2.5
Extreme (30C)	1732.5	9.3	0.005376	2.5
Extreme (10C)	1732.5	8.5	0.004909	2.5
Extreme (0C)	1732.5	8.3	0.004805	2.5
Extreme (-10C)	1732.5	8.9	0.005162	2.5
Extreme (-20C)	1732.5	8.5	0.004910	2.5
Extreme (-30C)	1732.5	8.2	0.004731	2.5

***Note:** Frequency error measurements were made by using the build-in capability of the Wireless Communication Test Set.

10.3 LTE BAND 5

QPSK, (10MHz BANDWIDTH)

Frequency error vs. Voltage

Voltage [Vdc]	Frequency [MHz]	Frequency* Error[Hz]	Frequency Error[ppm]	Limit [ppm]
BAND 5 QPSK, (CH 20525 RB size 50 RB Offset 0 10MHz BANDWIDTH)				
3.4	836.5	5.7	0.006843	2.5
3.87	836.5	7.1	0.008492	2.5
4.2	836.5	5.1	0.006083	2.5

Frequency error vs. Temperature

Temperature [° C]	Frequency [MHz]	Frequency* Error[Hz]	Frequency Error[ppm]	Limit [ppm]
BAND 5 QPSK, (CH 20525 RB size 50 RB Offset 0 10MHz BANDWIDTH)				
Normal (25C)	836.5	6.5	0.007819	2.5
Extreme (50C)	836.5	5.8	0.006938	2.5
Extreme (40C)	836.5	5.7	0.006832	2.5
Extreme (30C)	836.5	6.1	0.007336	2.5
Extreme (10C)	836.5	5.4	0.006398	2.5
Extreme (0C)	836.5	5.7	0.006799	2.5
Extreme (-10C)	836.5	6.0	0.007143	2.5
Extreme (-20C)	836.5	5.8	0.006975	2.5
Extreme (-30C)	836.5	6.6	0.007941	2.5

16QAM, (10MHz BANDWIDTH)

Frequency error vs. Voltage

Voltage [Vdc]	Frequency [MHz]	Frequency* Error[Hz]	Frequency Error[ppm]	Limit [ppm]
BAND 5 16QAM, (CH 20525 RB size 50 RB Offset 0 10MHz BANDWIDTH)				
3.4	836.5	5.4	0.006502	2.5
3.87	836.5	7.1	0.008516	2.5
4.2	836.5	4.3	0.005196	2.5

Frequency error vs. Temperature

Temperature [° C]	Frequency [MHz]	Frequency* Error[Hz]	Frequency Error[ppm]	Limit [ppm]
BAND 5 16QAM, (CH 20525 RB size 50 RB Offset 0 10MHz BANDWIDTH)				
Normal (25C)	836.5	5.9	0.006994	2.5
Extreme (50C)	836.5	5.5	0.006614	2.5
Extreme (40C)	836.5	6.5	0.007741	2.5
Extreme (30C)	836.5	6.8	0.008140	2.5
Extreme (10C)	836.5	5.5	0.006519	2.5
Extreme (0C)	836.5	5.0	0.005997	2.5
Extreme (-10C)	836.5	5.9	0.007048	2.5
Extreme (-20C)	836.5	5.7	0.006816	2.5
Extreme (-30C)	836.5	6.1	0.007312	2.5

***Note:** Frequency error measurements were made by using the build-in capability of the Wireless Communication Test Set.

10.4 LTE BAND 7

QPSK, (20MHz BANDWIDTH)

Frequency error vs. Voltage

Voltage [Vdc]	Frequency [MHz]	Frequency* Error[Hz]	Frequency Error[ppm]	Limit [ppm]
BAND 7 QPSK, (CH 21100 RB size 100 RB Offset 0 20MHz BANDWIDTH)				
3.4	2535	9.6	0.003786	2.5
3.87	2535	8.7	0.003435	2.5
4.2	2535	8.8	0.003481	2.5

Frequency error vs. Temperature

Temperature [° C]	Frequency [MHz]	Frequency* Error[Hz]	Frequency Error[ppm]	Limit [ppm]
BAND 7 QPSK, (CH 21100 RB size 100 RB Offset 0 20MHz BANDWIDTH)				
Normal (25C)	2535	9.8	0.003874	2.5
Extreme (50C)	2535	8.7	0.003435	2.5
Extreme (40C)	2535	8.0	0.003144	2.5
Extreme (30C)	2535	8.9	0.003522	2.5
Extreme (10C)	2535	8.2	0.003251	2.5
Extreme (0C)	2535	8.7	0.003419	2.5
Extreme (-10C)	2535	9.7	0.003845	2.5
Extreme (-20C)	2535	9.3	0.003650	2.5
Extreme (-30C)	2535	8.6	0.003394	2.5

16QAM, (20MHz BANDWIDTH)

Frequency error vs. Voltage

Voltage [Vdc]	Frequency [MHz]	Frequency* Error[Hz]	Frequency Error[ppm]	Limit [ppm]
BAND 7 16QAM, (CH 21100 RB size 100 RB Offset 0 20MHz BANDWIDTH)				
3.4	2535	6.2	0.002448	2.5
3.87	2535	6.1	0.002410	2.5
4.2	2535	5.4	0.002118	2.5

Frequency error vs. Temperature

Temperature [° C]	Frequency [MHz]	Frequency* Error[Hz]	Frequency Error[ppm]	Limit [ppm]
BAND 7 16QAM, (CH 21100 RB size 100 RB Offset 0 20MHz BANDWIDTH)				
Normal (25C)	2535	6.9	0.002740	2.5
Extreme (50C)	2535	5.9	0.002346	2.5
Extreme (40C)	2535	4.9	0.001952	2.5
Extreme (30C)	2535	6.6	0.002623	2.5
Extreme (10C)	2535	5.6	0.002192	2.5
Extreme (0C)	2535	4.8	0.001890	2.5
Extreme (-10C)	2535	5.3	0.002084	2.5
Extreme (-20C)	2535	5.9	0.002339	2.5
Extreme (-30C)	2535	5.3	0.002071	2.5

***Note:** Frequency error measurements were made by using the build-in capability of the Wireless Communication Test Set.

10.5 LTE BAND 12

QPSK, (10MHz BANDWIDTH)

Frequency error vs. Voltage

Voltage [Vdc]	Frequency [MHz]	Frequency* Error[Hz]	Frequency Error[ppm]	Limit [ppm]
BAND 12 QPSK, (CH 23095 RB size 50 RB Offset 0 10MHz BANDWIDTH)				
3.4	707.5	8.6	0.012197	2.5
3.87	707.5	9.8	0.013845	2.5
4.2	707.5	9.0	0.012686	2.5

Frequency error vs. Temperature

Temperature [° C]	Frequency [MHz]	Frequency* Error[Hz]	Frequency Error[ppm]	Limit [ppm]
BAND 12 QPSK, (CH 23095 RB size 50 RB Offset 0 10MHz BANDWIDTH)				
Normal (25C)	707.5	8.5	0.012073	2.5
Extreme (50C)	707.5	7.4	0.010450	2.5
Extreme (40C)	707.5	7.5	0.010607	2.5
Extreme (30C)	707.5	8.5	0.011973	2.5
Extreme (10C)	707.5	7.7	0.010843	2.5
Extreme (0C)	707.5	8.7	0.012311	2.5
Extreme (-10C)	707.5	8.0	0.011349	2.5
Extreme (-20C)	707.5	8.6	0.012226	2.5
Extreme (-30C)	707.5	7.9	0.011129	2.5

16QAM, (10MHz BANDWIDTH)

Frequency error vs. Voltage

Voltage [Vdc]	Frequency [MHz]	Frequency* Error[Hz]	Frequency Error[ppm]	Limit [ppm]
BAND 12 16QAM, (CH 23095 RB size 50 RB Offset 0 10MHz BANDWIDTH)				
3.4	707.5	7.3	0.010363	2.5
3.87	707.5	8.4	0.011842	2.5
4.2	707.5	7.9	0.011132	2.5

Frequency error vs. Temperature

Temperature [° C]	Frequency [MHz]	Frequency* Error[Hz]	Frequency Error[ppm]	Limit [ppm]
BAND 12 QPSK, (CH 23095 RB size 50 RB Offset 0 10MHz BANDWIDTH)				
Normal (25C)	707.5	6.5	0.009175	2.5
Extreme (50C)	707.5	5.5	0.007765	2.5
Extreme (40C)	707.5	6.4	0.009110	2.5
Extreme (30C)	707.5	-7.7	-0.010912	2.5
Extreme (10C)	707.5	-8.2	-0.011590	2.5
Extreme (0C)	707.5	2.9	0.004100	2.5
Extreme (-10C)	707.5	-5.2	-0.007292	2.5
Extreme (-20C)	707.5	-8.7	-0.012302	2.5
Extreme (-30C)	707.5	-10.2	-0.014350	2.5

***Note:** Frequency error measurements were made by using the build-in capability of the Wireless Communication Test Set.

10.6 LTE BAND 17

QPSK, (10MHz BANDWIDTH)

Frequency error vs. Voltage

Voltage [Vdc]	Frequency [MHz]	Frequency* Error[Hz]	Frequency Error[ppm]	Limit [ppm]
BAND 17 QPSK, (CH 23790 RB size 50 RB Offset 0 10MHz BANDWIDTH)				
3.4	710.0	9.7	0.013650	2.5
3.87	710.0	8.7	0.012296	2.5
4.2	710.0	7.7	0.010840	2.5

Frequency error vs. Temperature

Temperature [° C]	Frequency [MHz]	Frequency* Error[Hz]	Frequency Error[ppm]	Limit [ppm]
BAND 17 QPSK, (CH 23790 RB size 50 RB Offset 0 10MHz BANDWIDTH)				
Normal (25C)	710.0	9.9	0.013903	2.5
Extreme (50C)	710.0	9.0	0.012700	2.5
Extreme (40C)	710.0	8.3	0.011748	2.5
Extreme (30C)	710.0	8.8	0.012406	2.5
Extreme (10C)	710.0	9.2	0.012949	2.5
Extreme (0C)	710.0	8.0	0.011311	2.5
Extreme (-10C)	710.0	8.7	0.012196	2.5
Extreme (-20C)	710.0	9.1	0.012756	2.5
Extreme (-30C)	710.0	8.2	0.011521	2.5

16QAM, (10MHz BANDWIDTH)

Frequency error vs. Voltage

Voltage [Vdc]	Frequency [MHz]	Frequency* Error[Hz]	Frequency Error[ppm]	Limit [ppm]
BAND 17 16QAM, (CH 23790 RB size 50 RB Offset 0 10MHz BANDWIDTH)				
3.4	710.0	10.3	0.014507	2.5
3.87	710.0	9.3	0.013138	2.5
4.2	710.0	8.7	0.012271	2.5

Frequency error vs. Temperature

Temperature [° C]	Frequency [MHz]	Frequency* Error[Hz]	Frequency Error[ppm]	Limit [ppm]
BAND 17 QPSK, (CH 23790 RB size 50 RB Offset 0 10MHz BANDWIDTH)				
Normal (25C)	710.0	9.2	0.012931	2.5
Extreme (50C)	710.0	9.0	0.012693	2.5
Extreme (40C)	710.0	8.0	0.011318	2.5
Extreme (30C)	710.0	8.5	0.012039	2.5
Extreme (10C)	710.0	7.6	0.010767	2.5
Extreme (0C)	710.0	8.7	0.012252	2.5
Extreme (-10C)	710.0	9.7	0.013597	2.5
Extreme (-20C)	710.0	9.3	0.013126	2.5
Extreme (-30C)	710.0	8.2	0.011594	2.5

***Note:** Frequency error measurements were made by using the build-in capability of the Wireless Communication Test Set.

11. Peak-to-Average Ratio

11.1 Description of the PAR Measurement

The peak-to-average ratio (PAR) of the transmission may not exceed 13 dB.

11.2 Measuring Instruments

See list of measuring instruments of this test report.

11.3 Test Procedures

1. The EUT was connected to Spectrum Analyzer and Base Station via power divider.
2. The RF output of EUT was connected to the spectrum analyzer by RF cable and attenuator. The path loss was compensated to the results for each measurement.
3. For GSM/EGPRS operating modes:
 - a. Set the RBW = 1MHz, VBW = 1MHz, Peak detector in spectrum analyzer.
 - b. Set EUT in maximum power output, and triggered the burst signal.
 - c. Measured respectively the Peak level and Mean level, and the deviation was recorded as Peak to Average Ratio.
4. For UMTS operating modes:
 - a. Set the CCDF (Complementary Cumulative Distribution Function) option in spectrum analyzer.
 - b. The highest RF powers were measured and recorded the maximum PAPR level associated with a probability of 0.1 %.

11.4 Test Setup

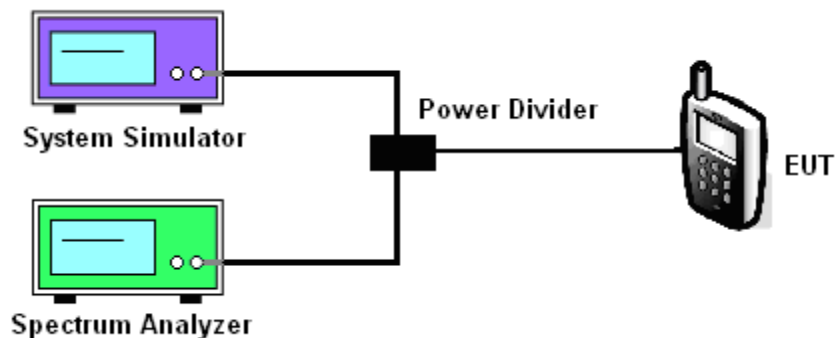

MODES TESTED

- LTE Band 2/4/5/7/12/17
-

Test data reference attachment.

----END OF REPORT----