

WCDMA Band5 Channel=4132

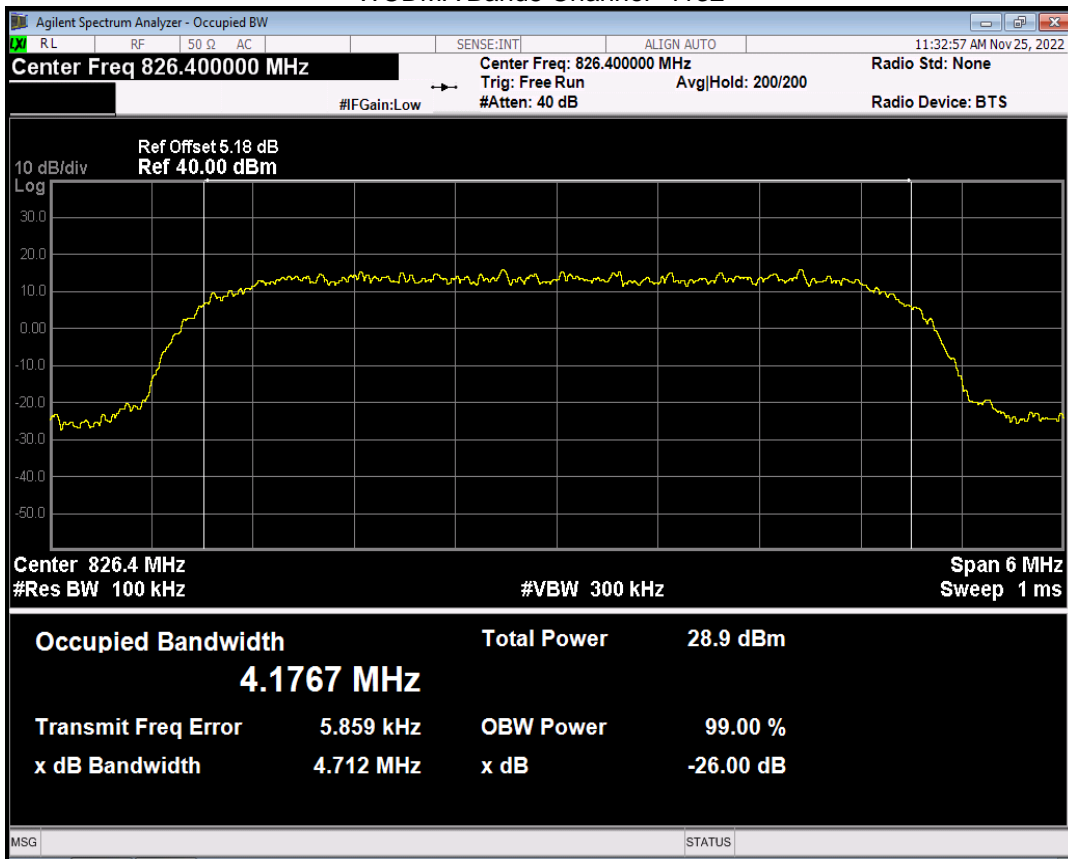

WCDMA Band5 Channel=4182

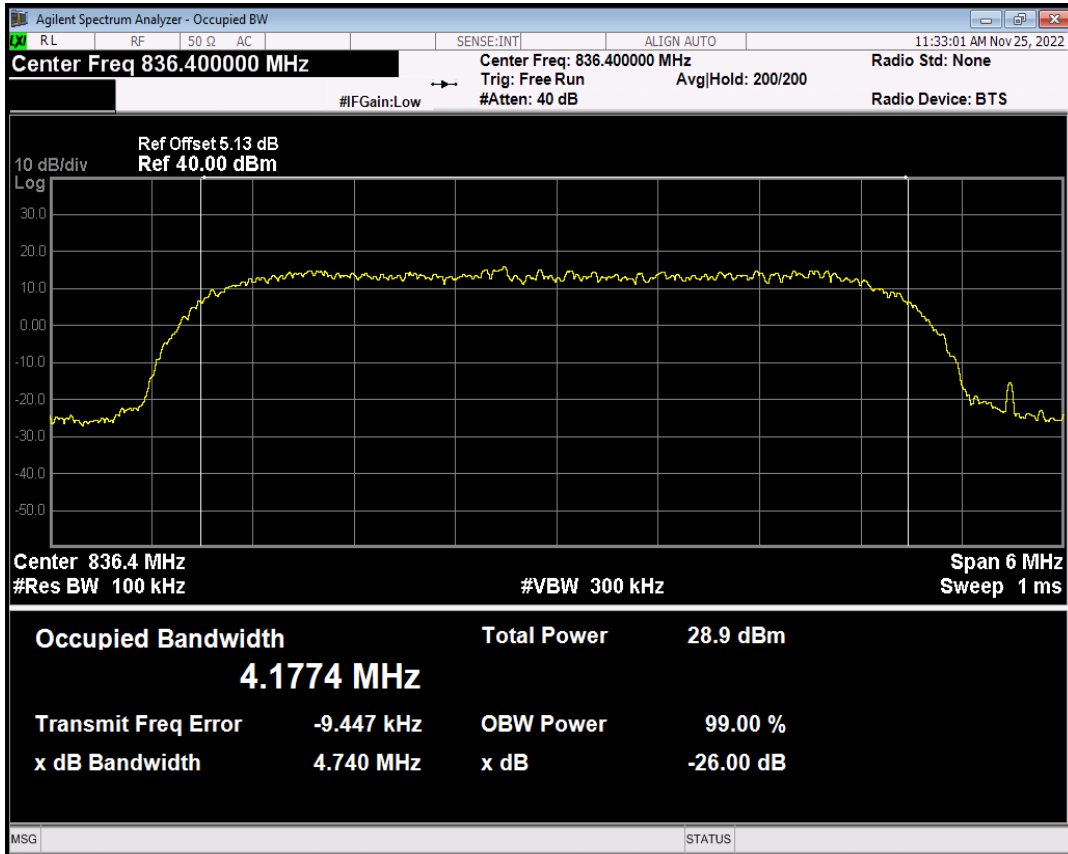

WCDMA Band5 Channel=4233

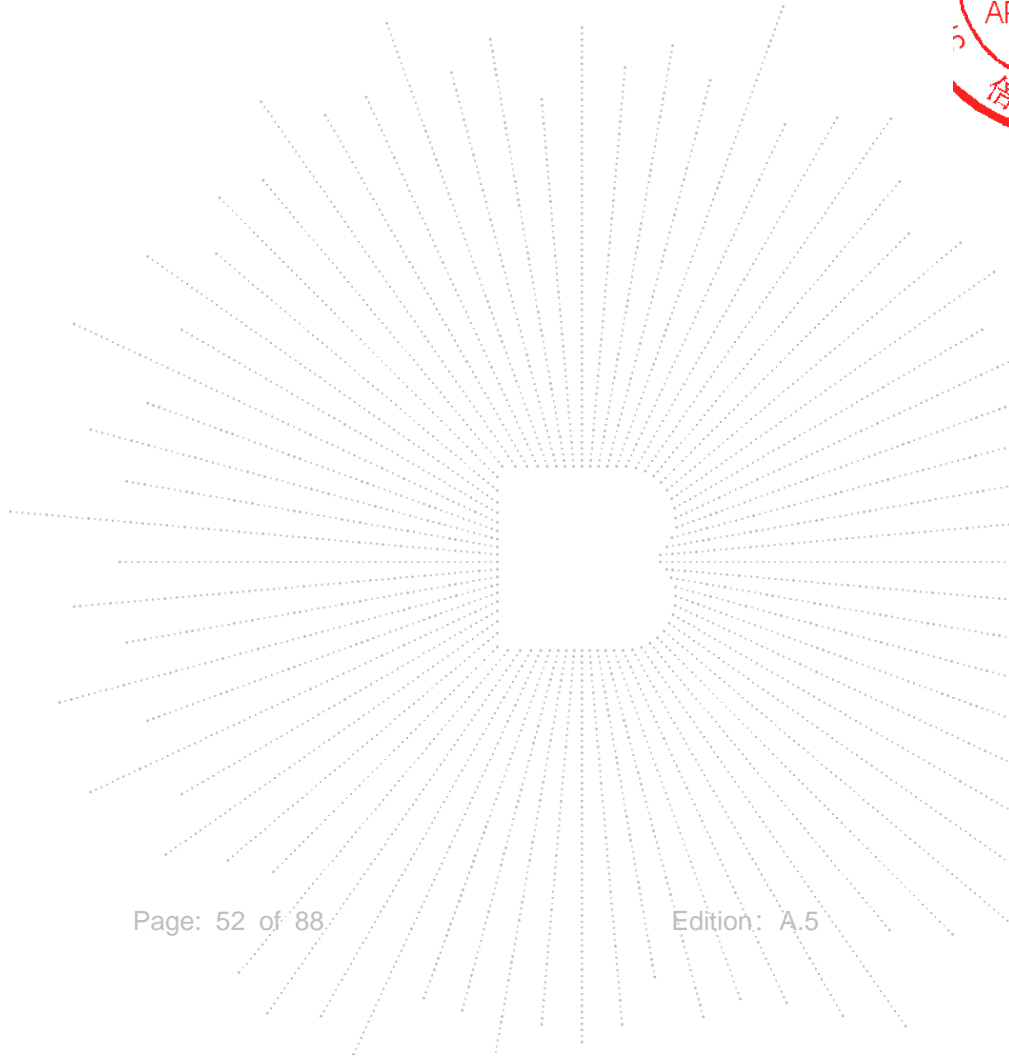
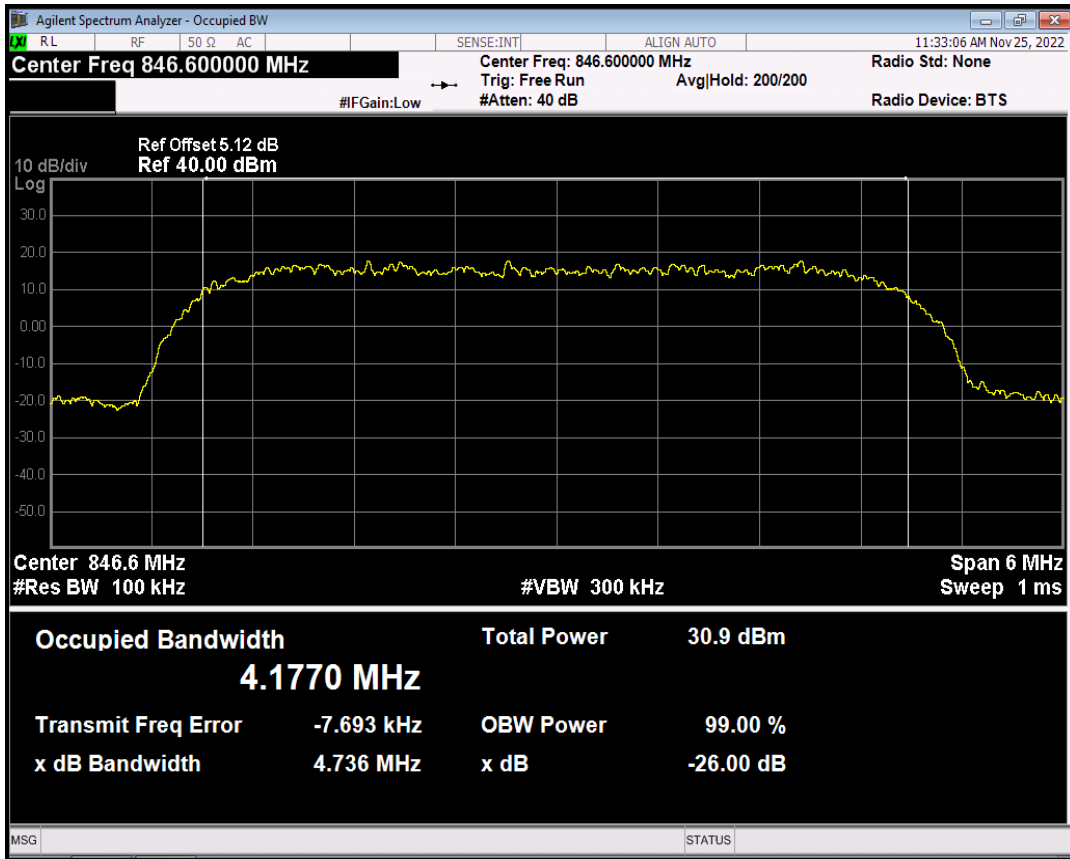

9. Out of Band Emissions at Antenna Terminal

9.1 Block Diagram Of Test Setup

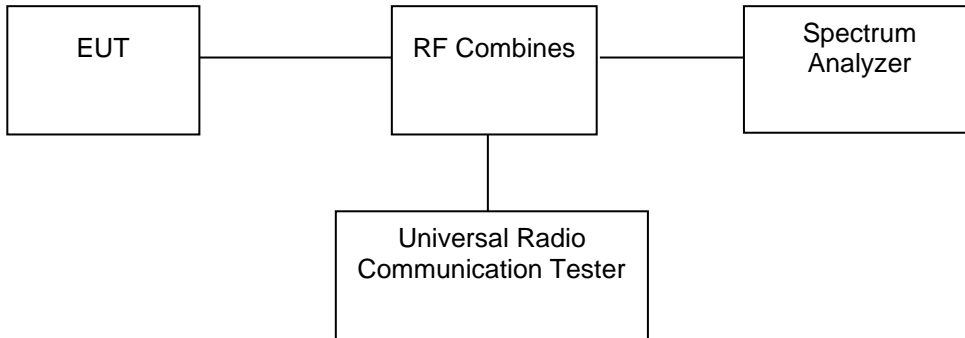

9.2 Limit

According to §22.917(a), the power of any emissions outside of the authorized operating frequency ranges must be attenuated below the transmitting power (P) by a factor of at least $43 + 10 \log(P)$ dB.

According to §24.238(a), the power of any emissions outside of the authorized operating frequency ranges must be attenuated below the transmitting power (P) by a factor of at least $43 + 10 \log(P)$ dB.

According to §27.53 (h), the power of any emission outside a licensee's frequency block shall be attenuated below the transmitter power (P) in watts by at least $43 + 10 \log_{10}(P)$ dB.

9.3 Test procedure

The RF output terminal of the transmitter was connected to the input of the spectrum analyzer via a suitable attenuation. The RBW of the spectrum analyzer was set to 100kHz and 1MHz for the scan frequency from 30MHz to 1GHz and the scan frequency from 1GHz to up to 10th harmonic

9.4 Test Result

GSM850 Channel=128

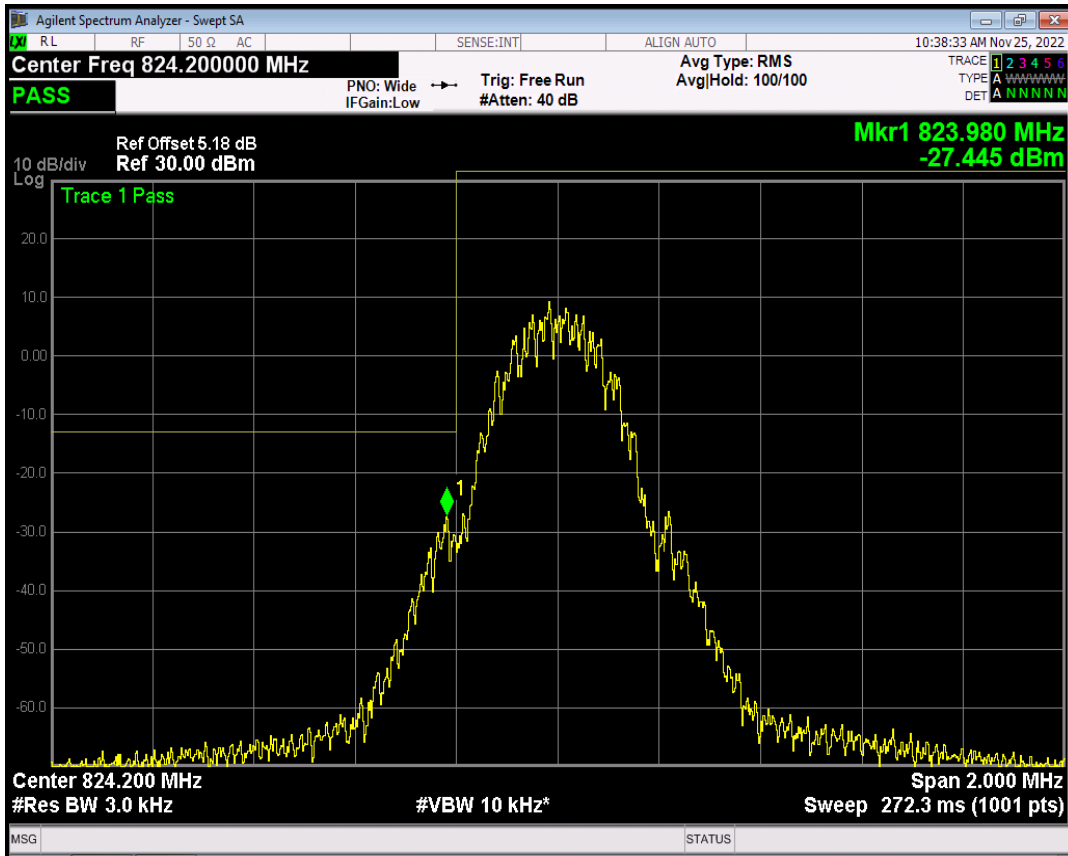

GSM850 Channel=251

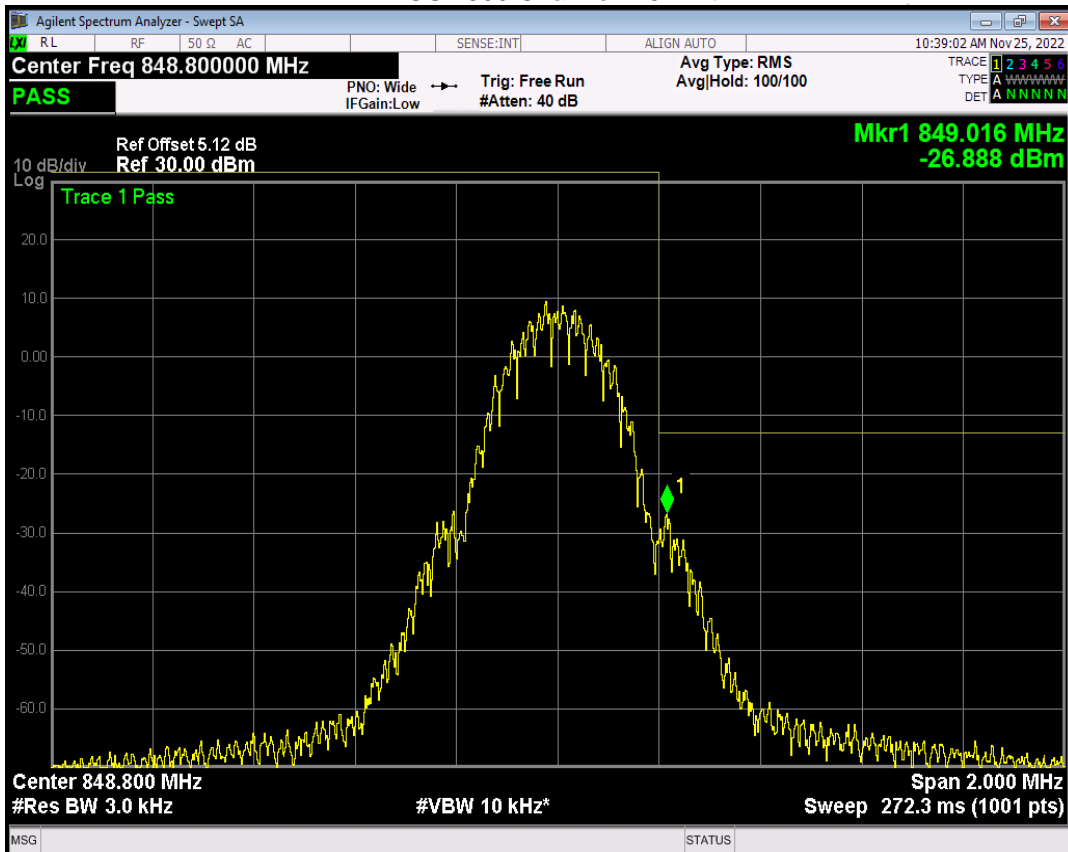

TEC
TO
OVB
檢

GPRS850 Channel=128

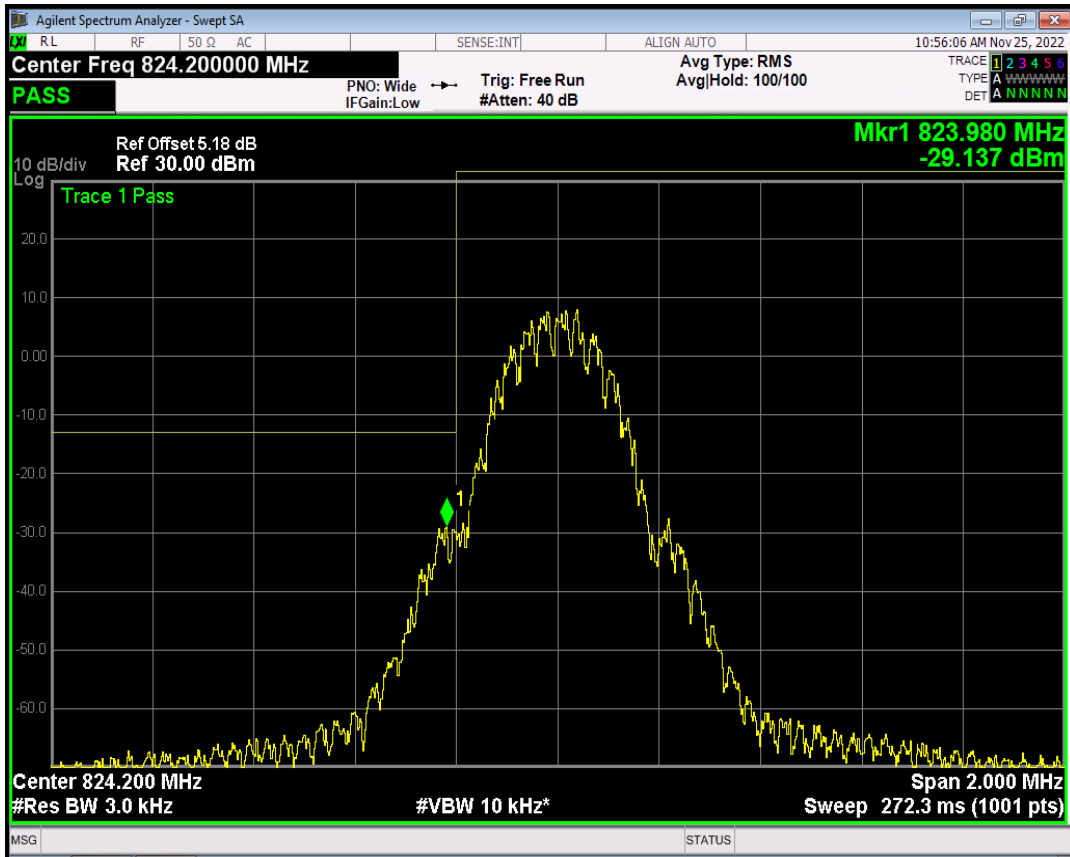

GPRS850 Channel=251

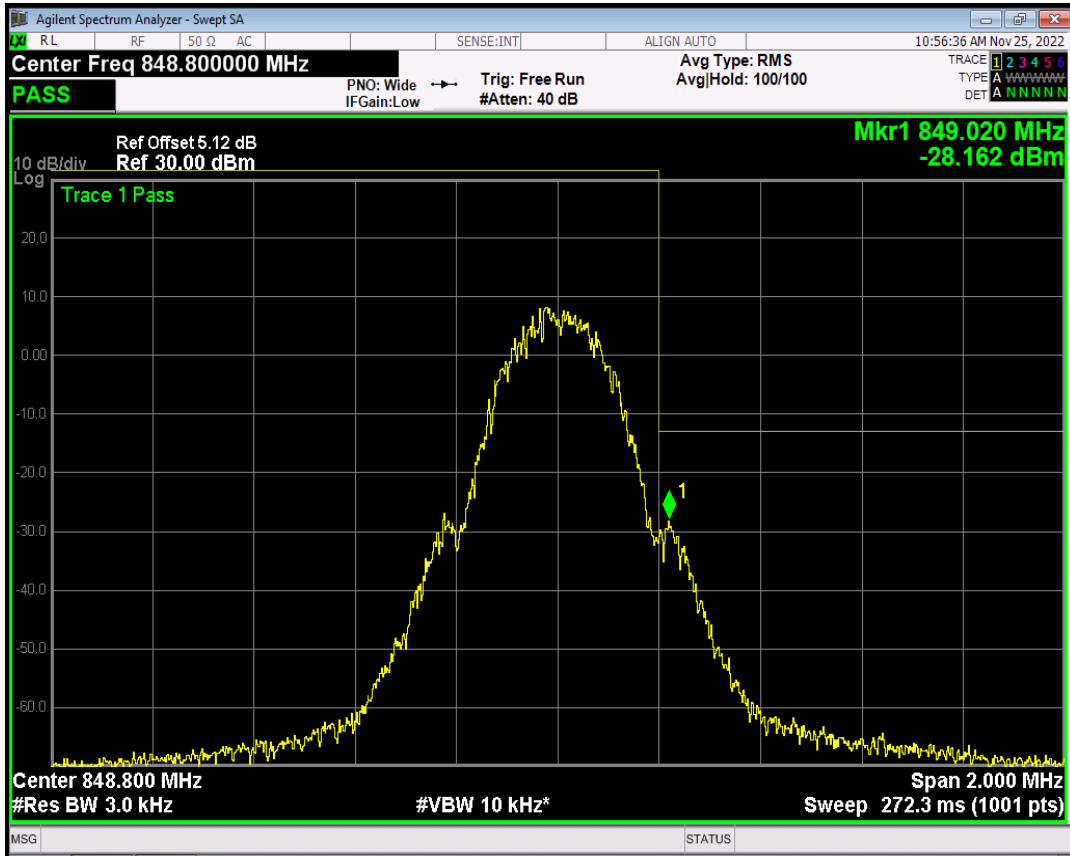

EGPRS850 Channel=128

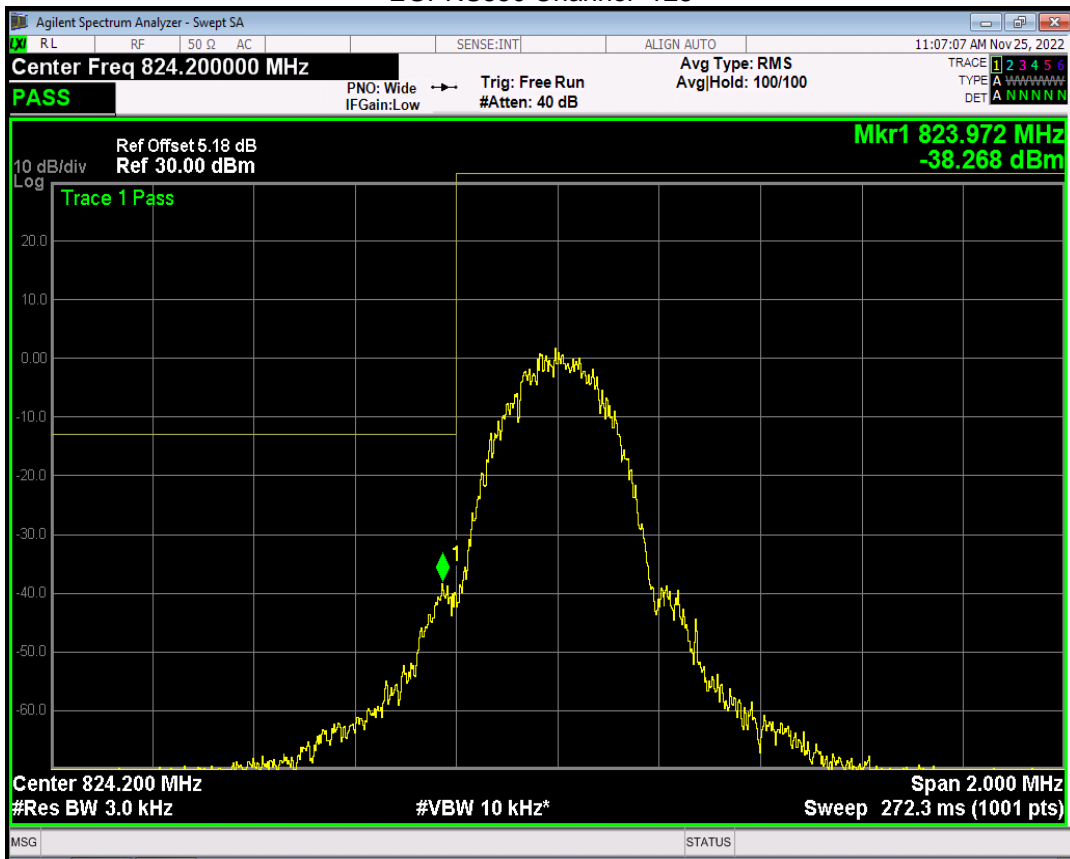

EGPRS850 Channel=251

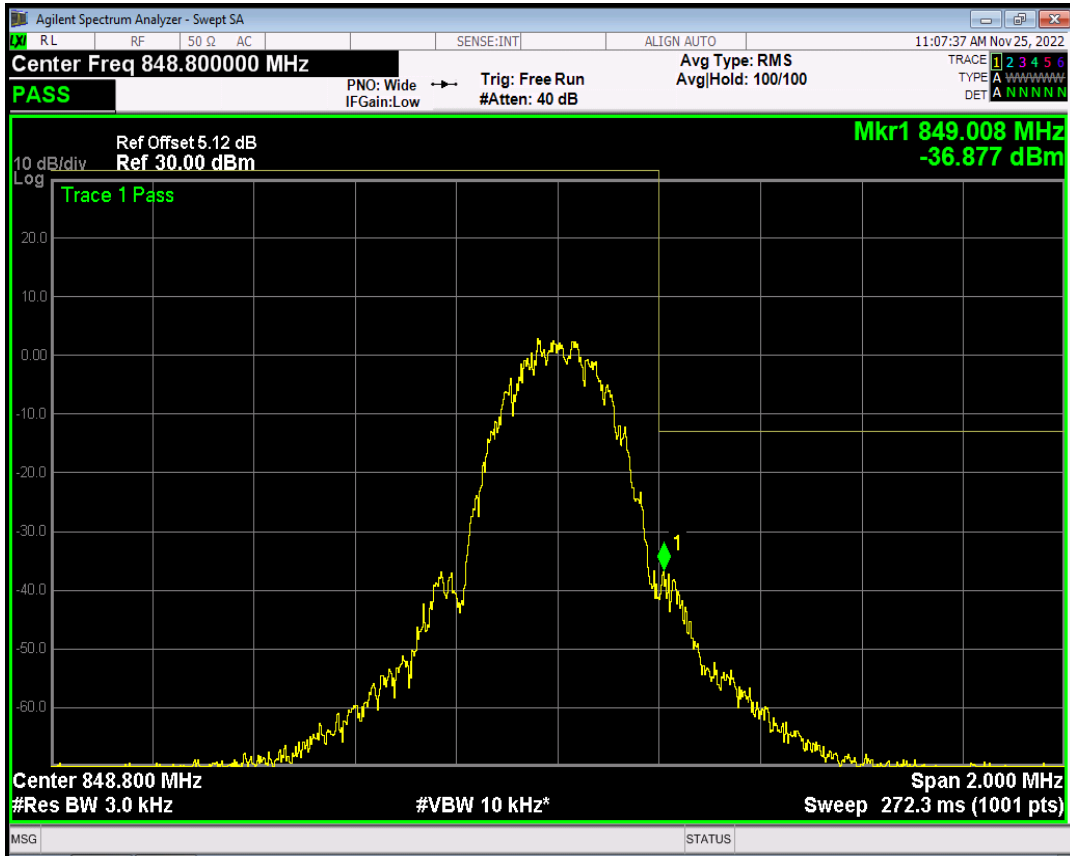

CO.LTD

GSM1900 Channel=512

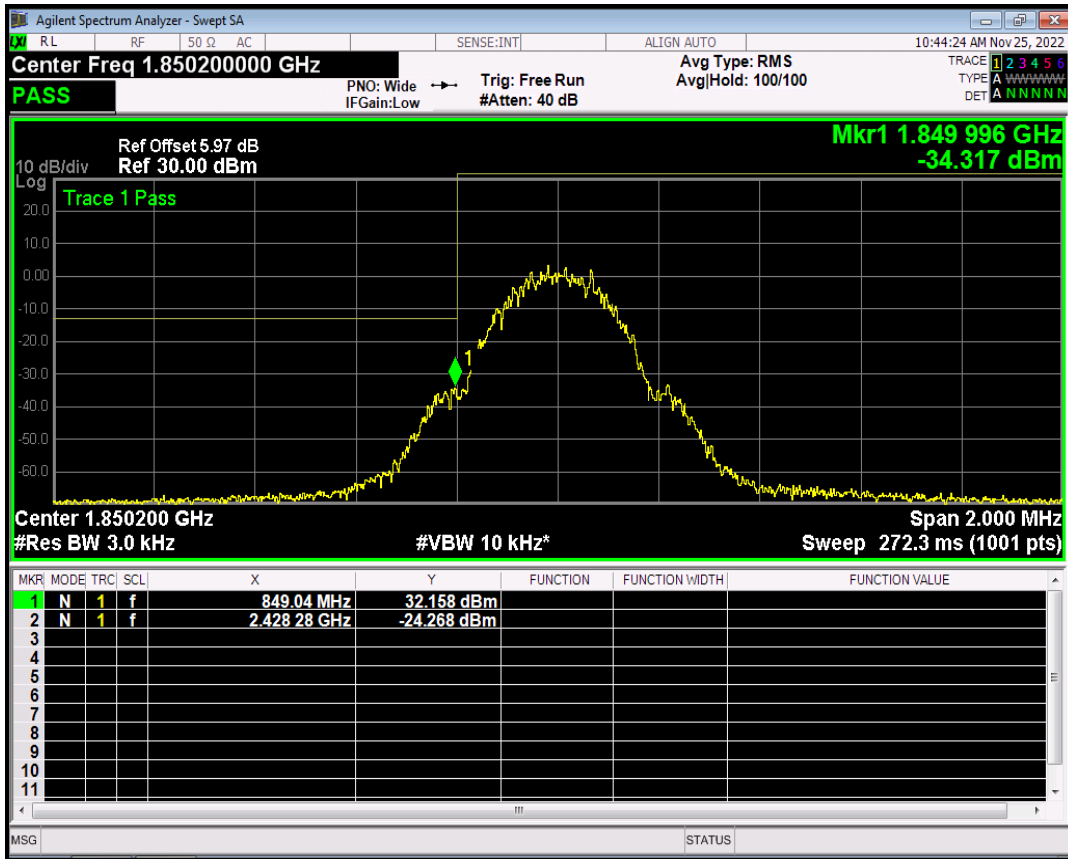

GSM1900 Channel=810

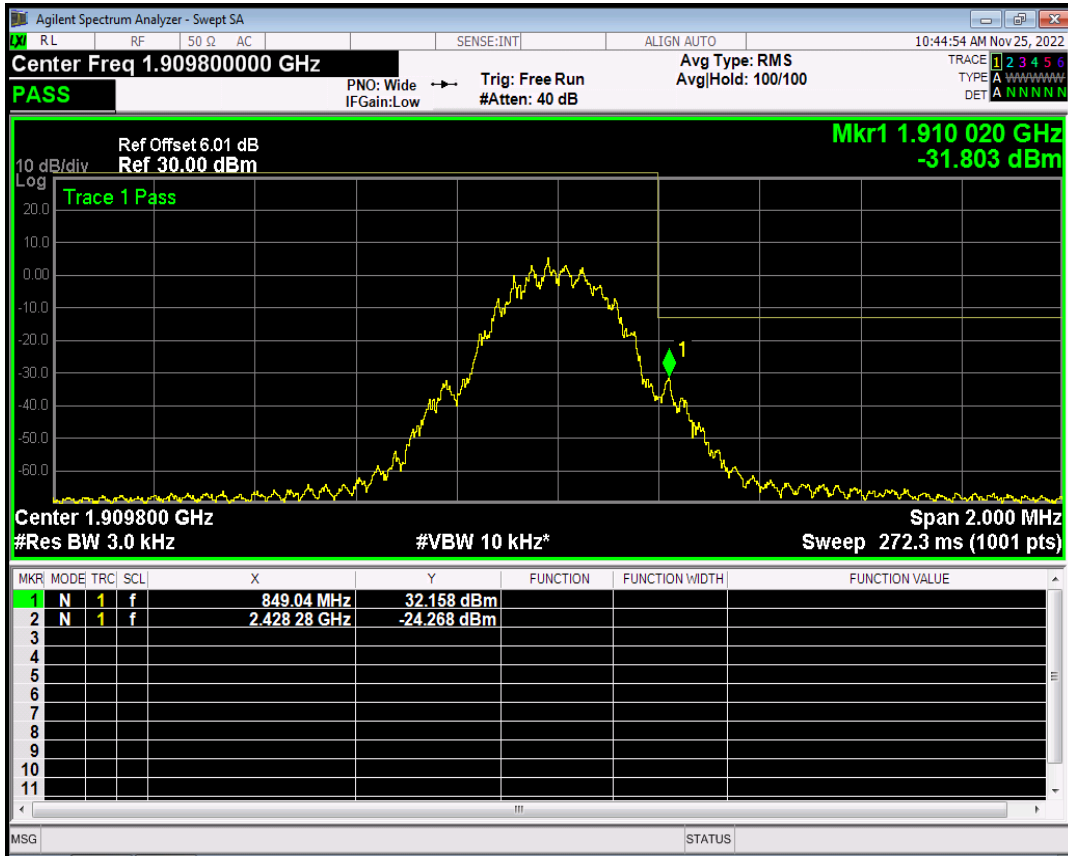

CHENZHEN

GPRS1900 Channel=512

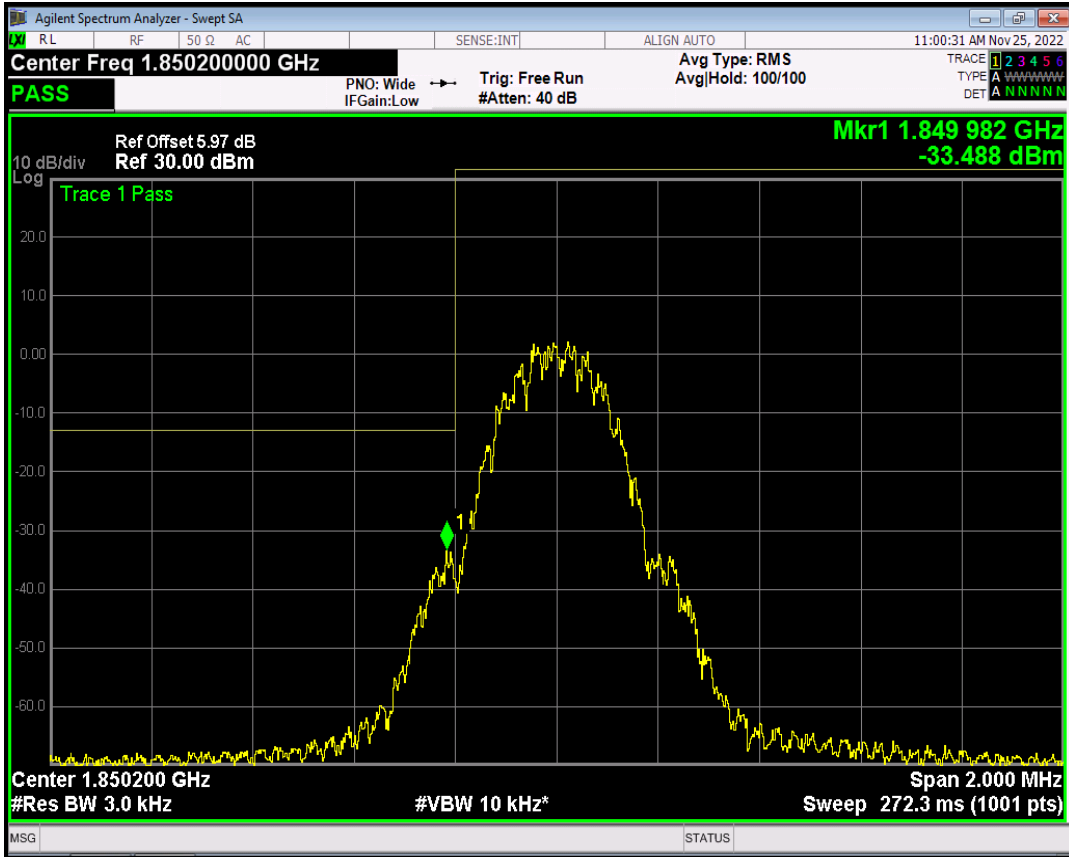

GPRS1900 Channel=810

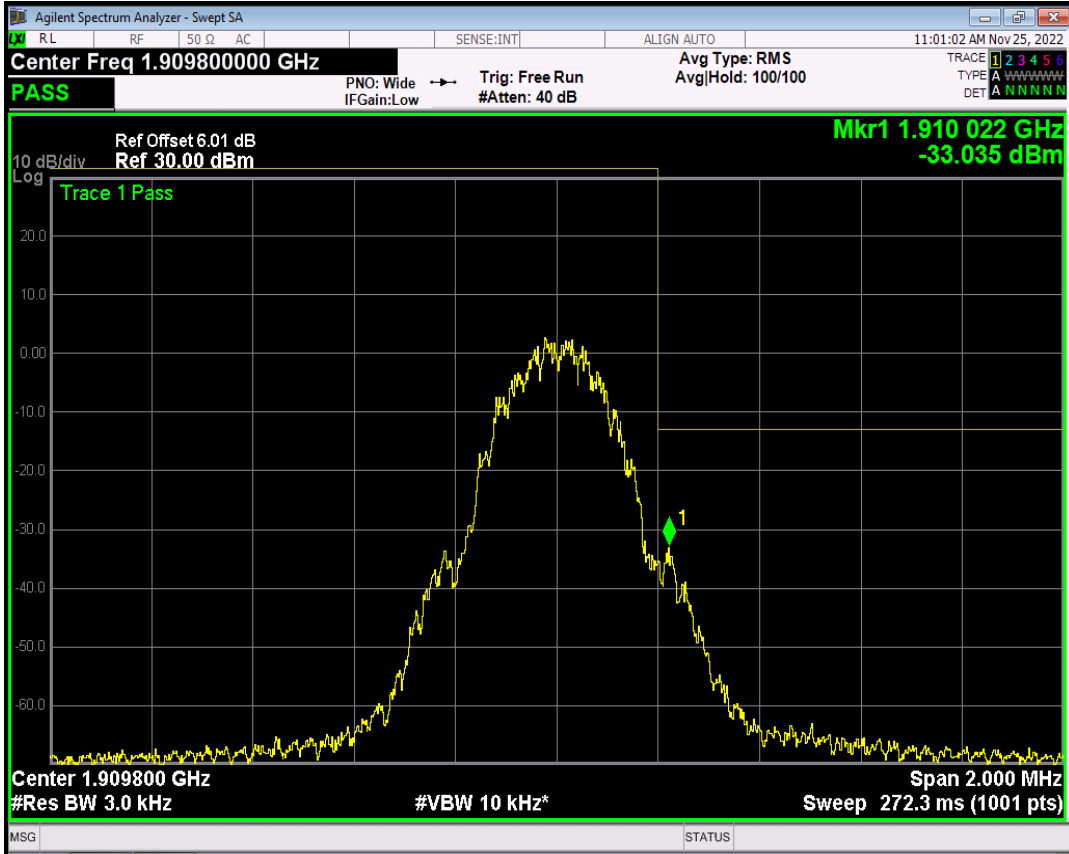

EGPRS1900 Channel=512

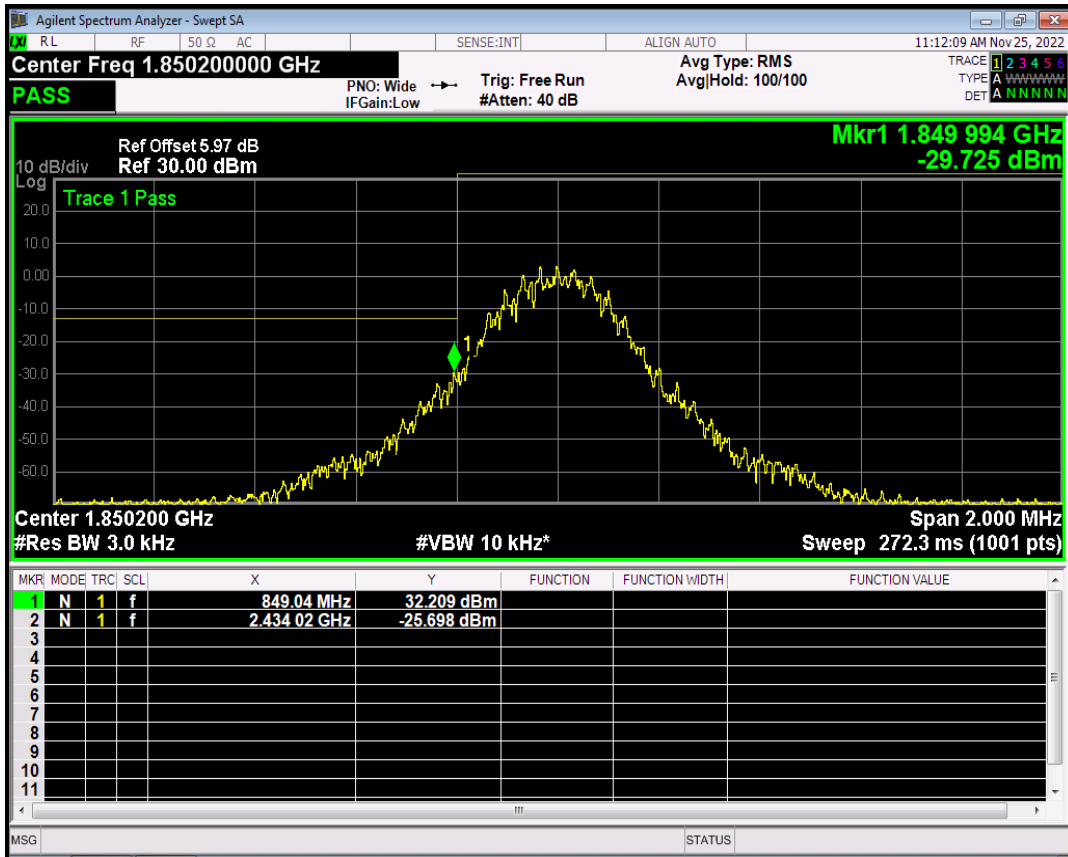

EGPRS1900 Channel=810

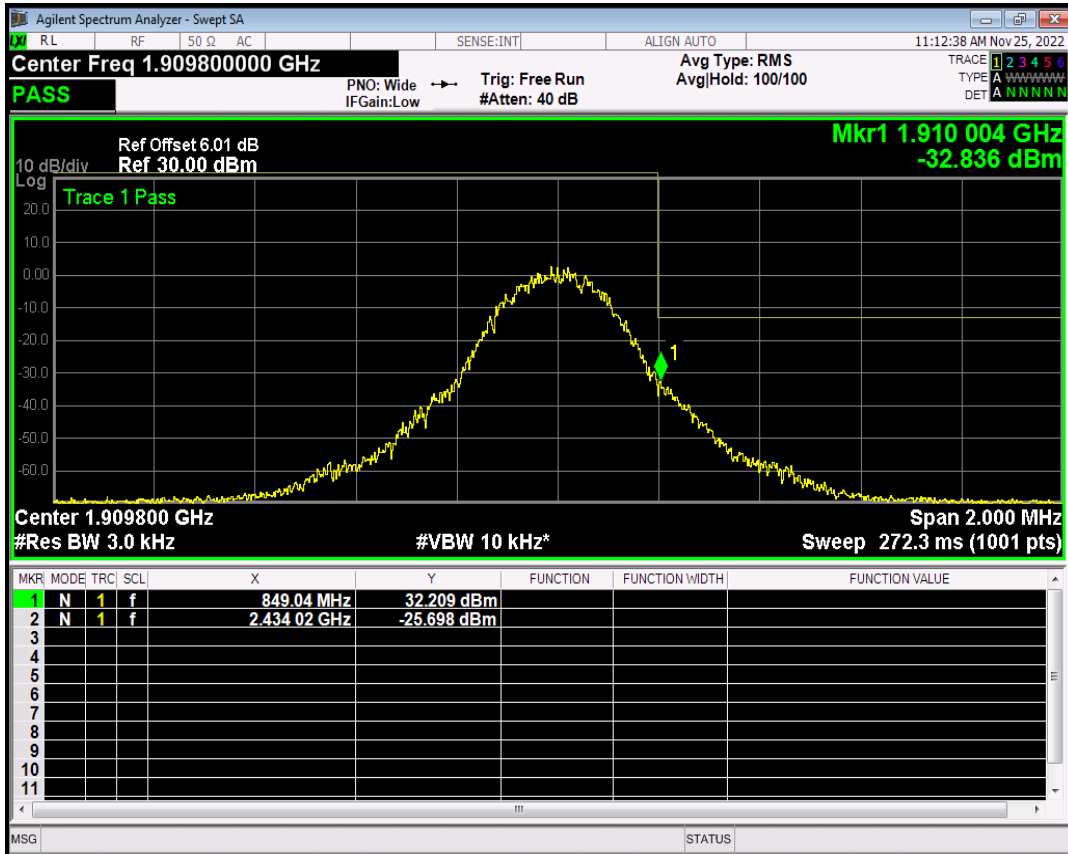

BCTC
 BCTC
 PPR
 检测

GSM850 Channel=128

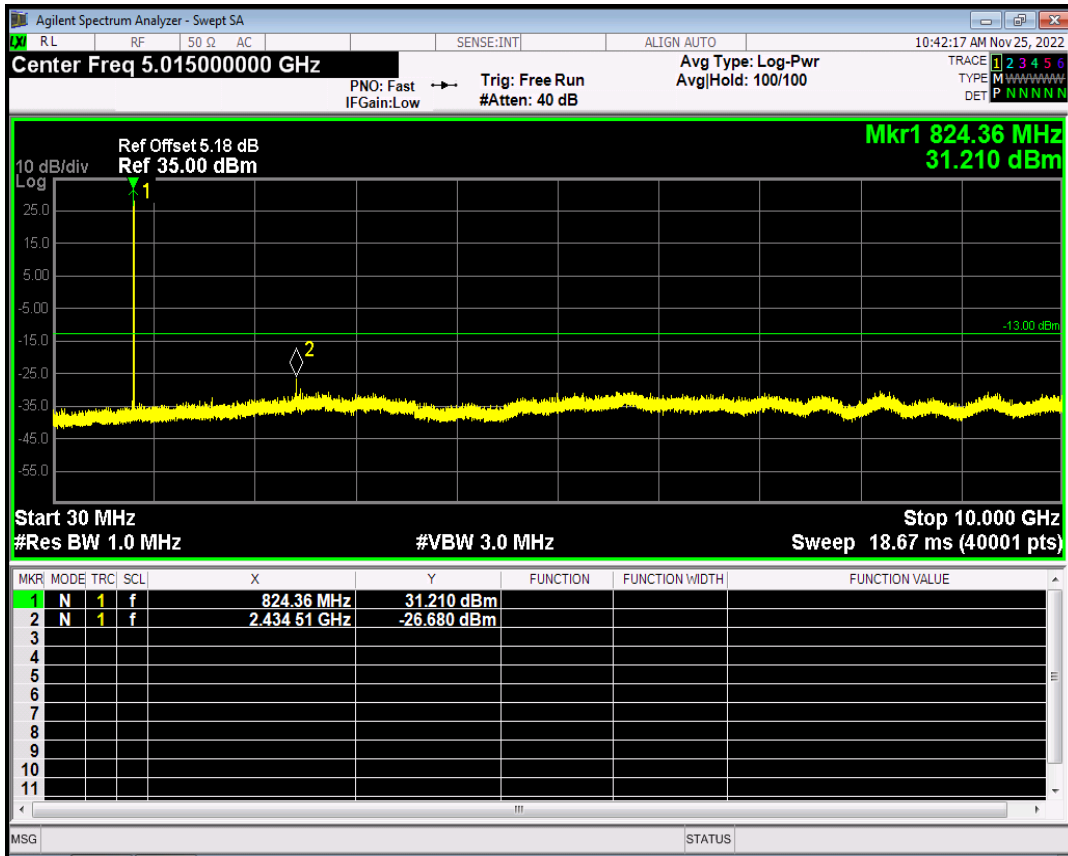

GSM850 Channel=190

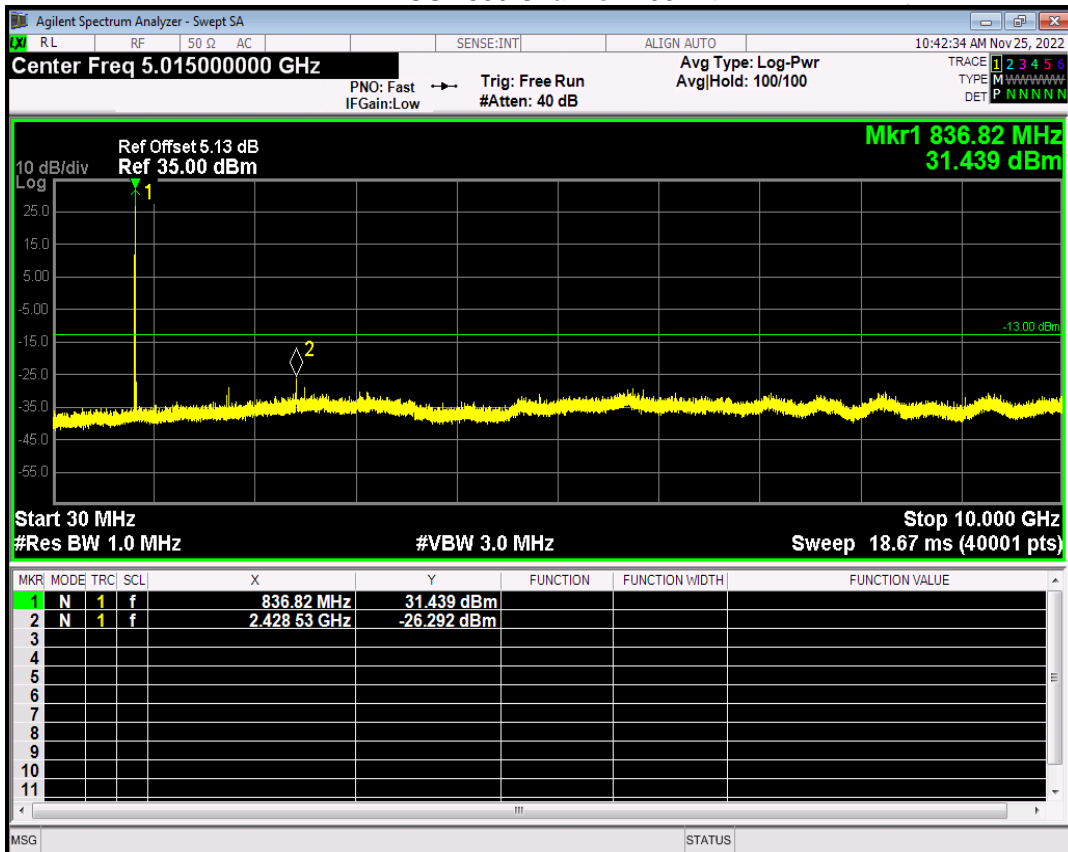
 検査
 OVER
 TO
 TEC

GSM850 Channel=251

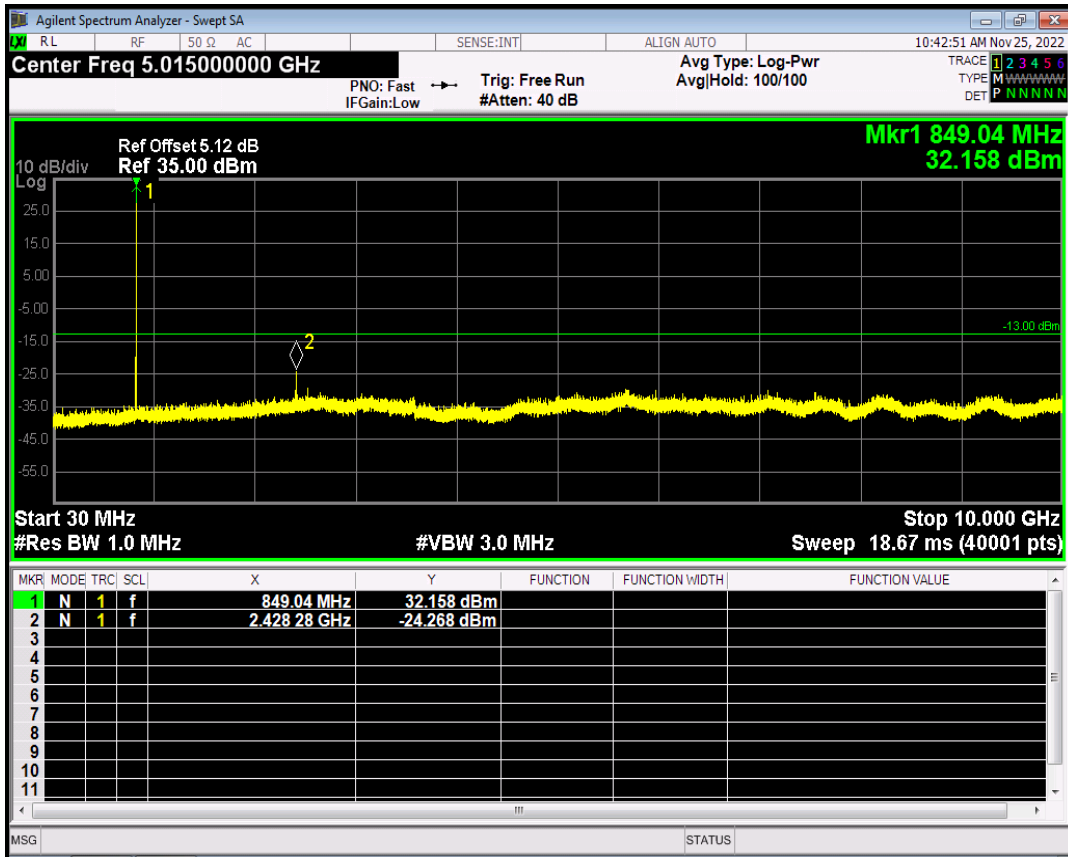

GPRS850 Channel=128

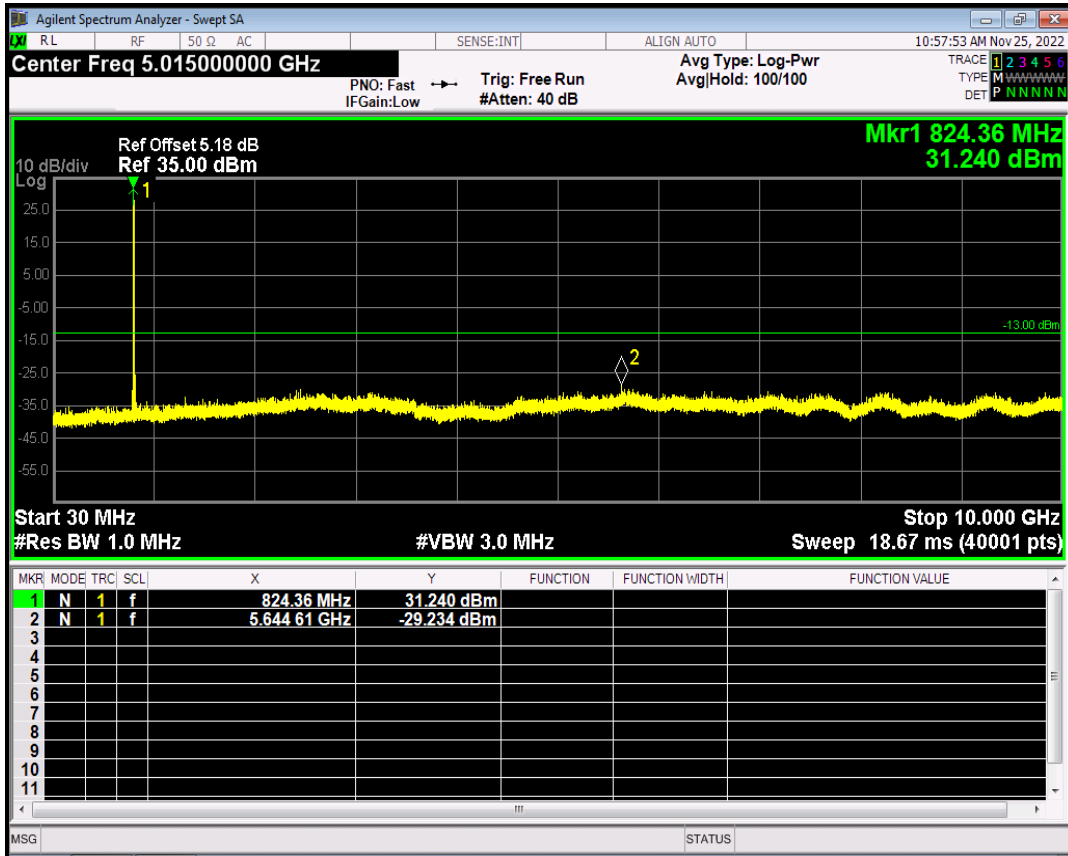

GPRS850 Channel=190

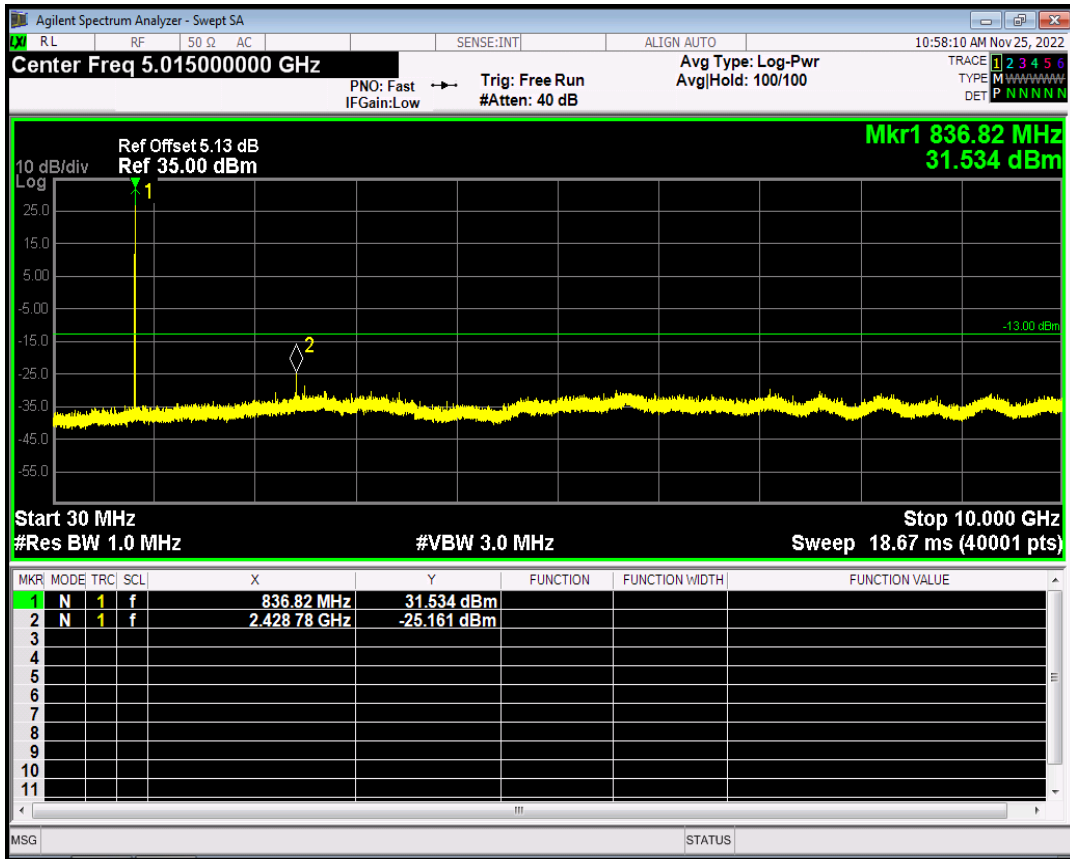

GPRS850 Channel=251

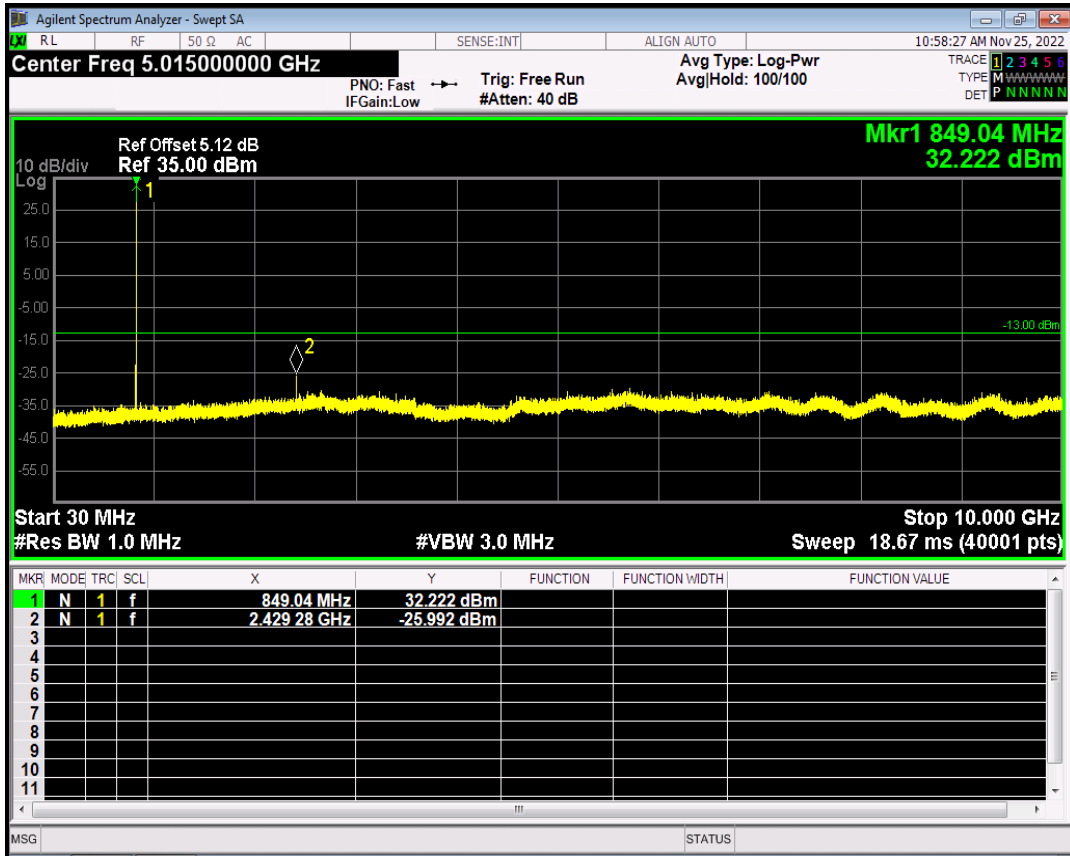

CO.LTD

EGPRS850 Channel=128

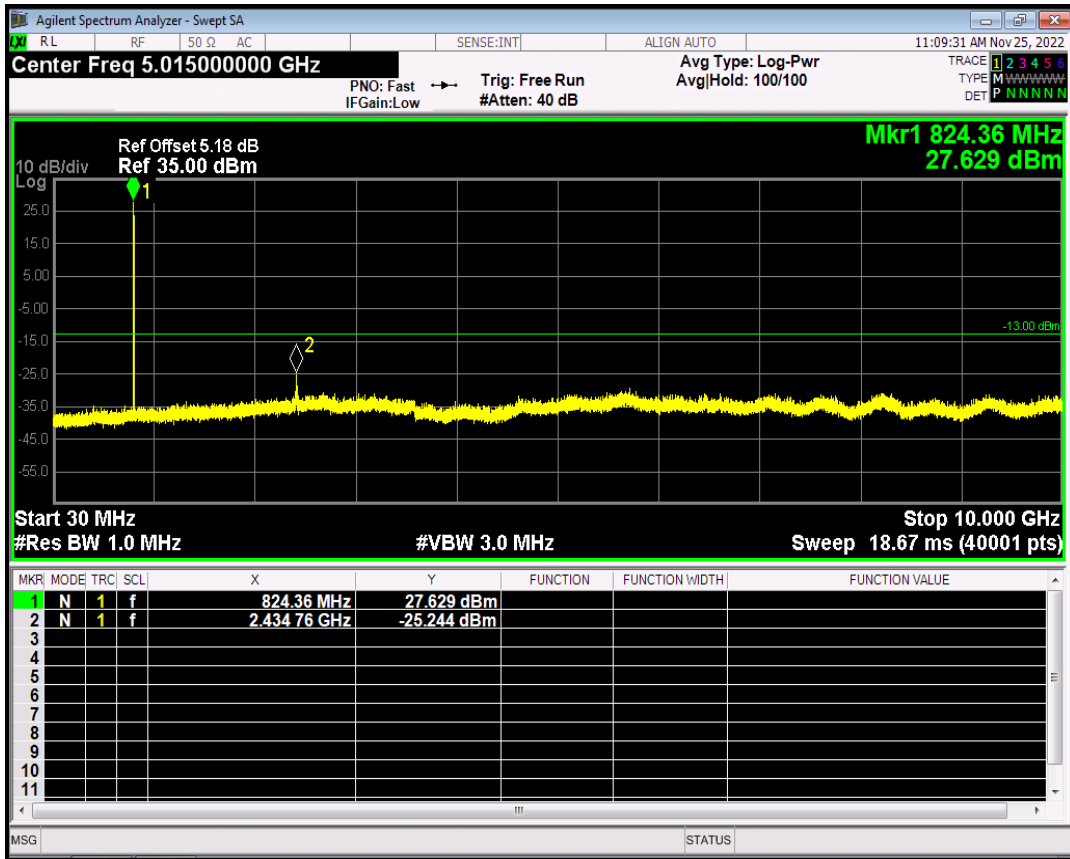

EGPRS850 Channel=190

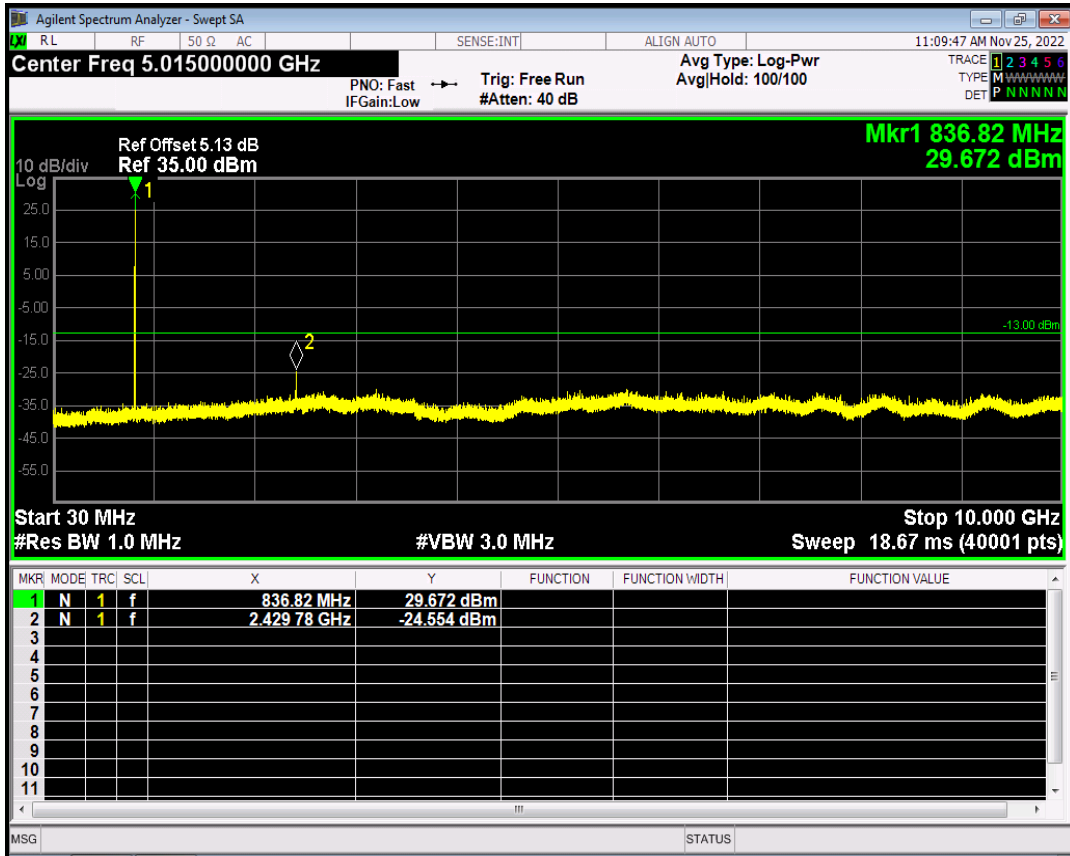

CHENZHEN

EGPRS850 Channel=251

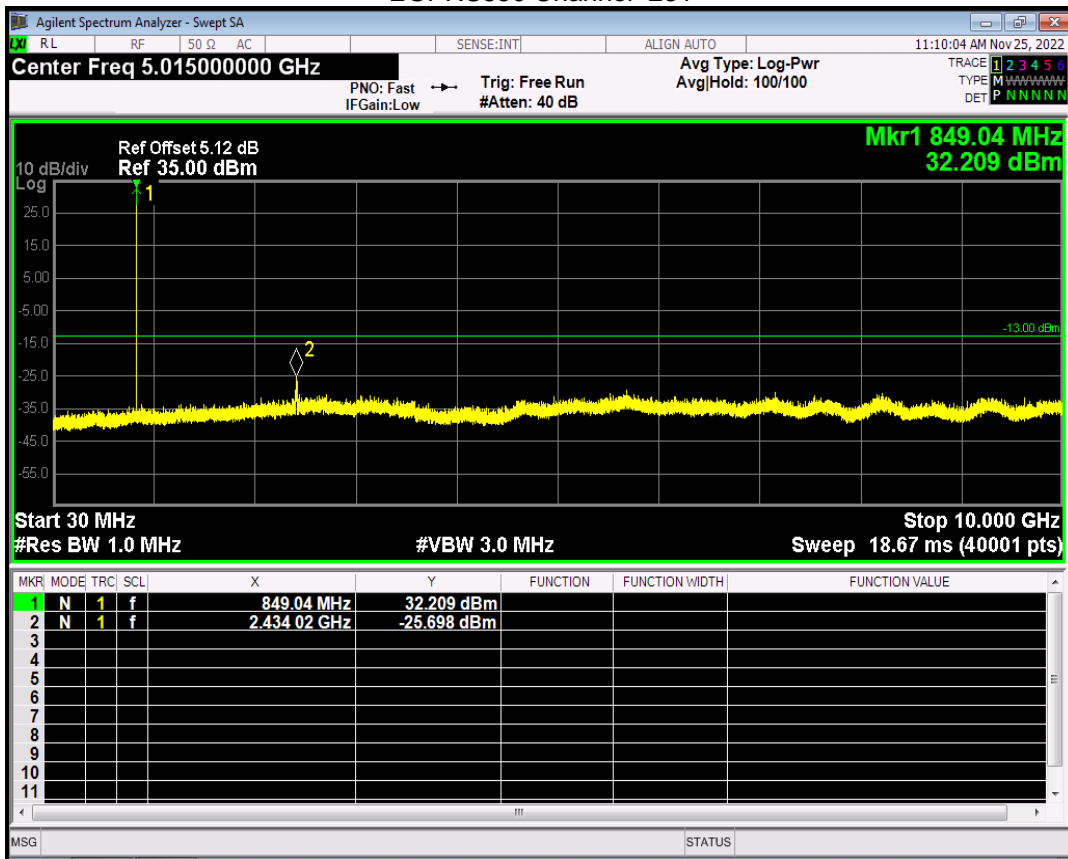

GSM1900 Channel=512

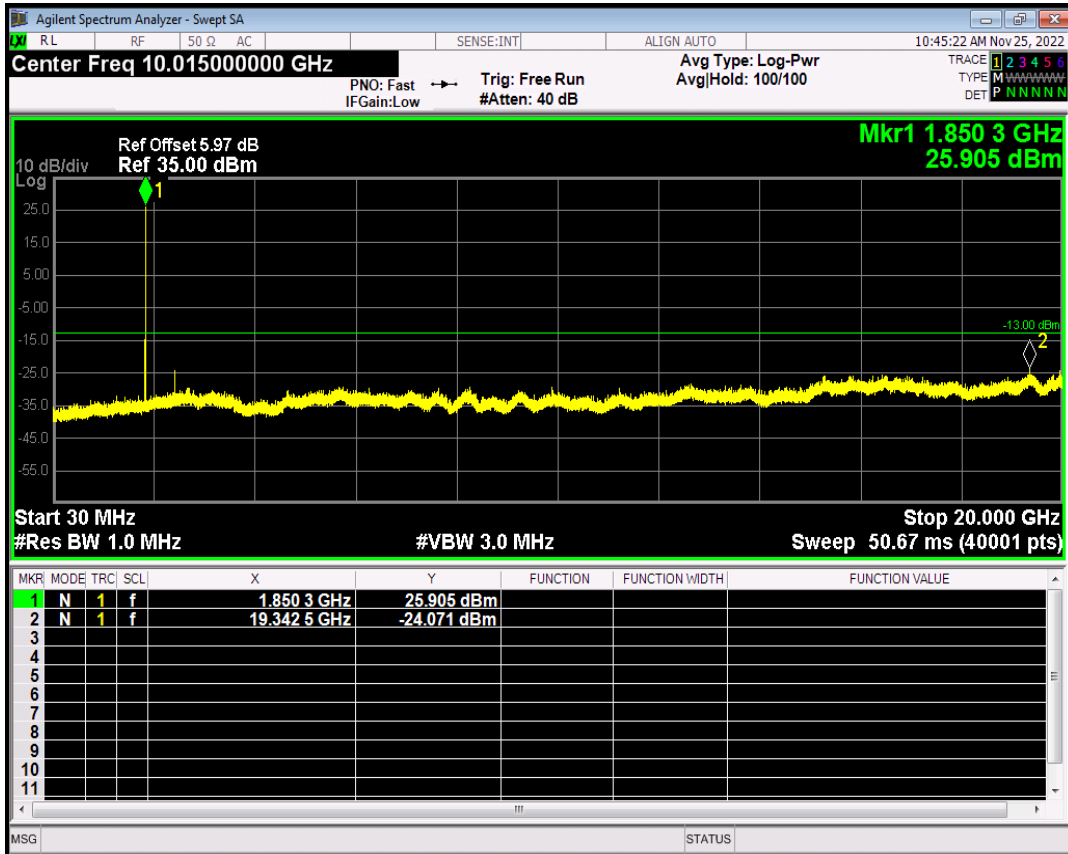

GSM1900 Channel=661

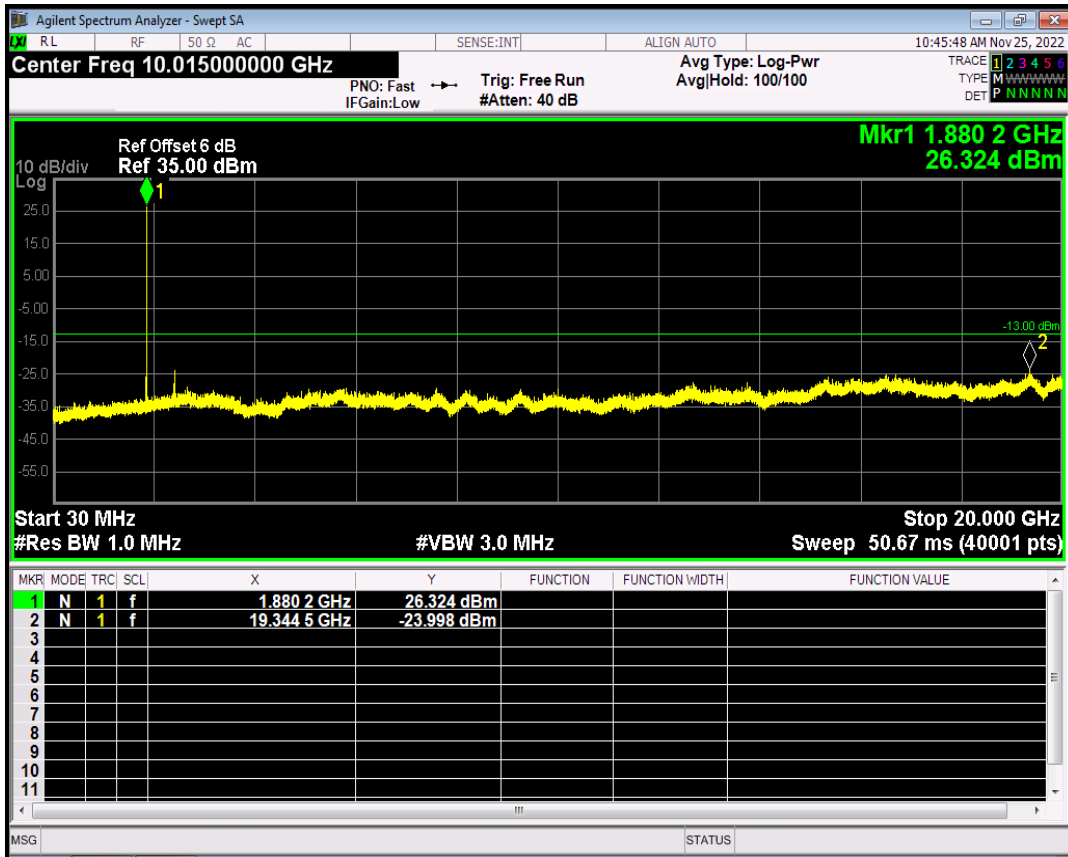

GSM1900 Channel=810

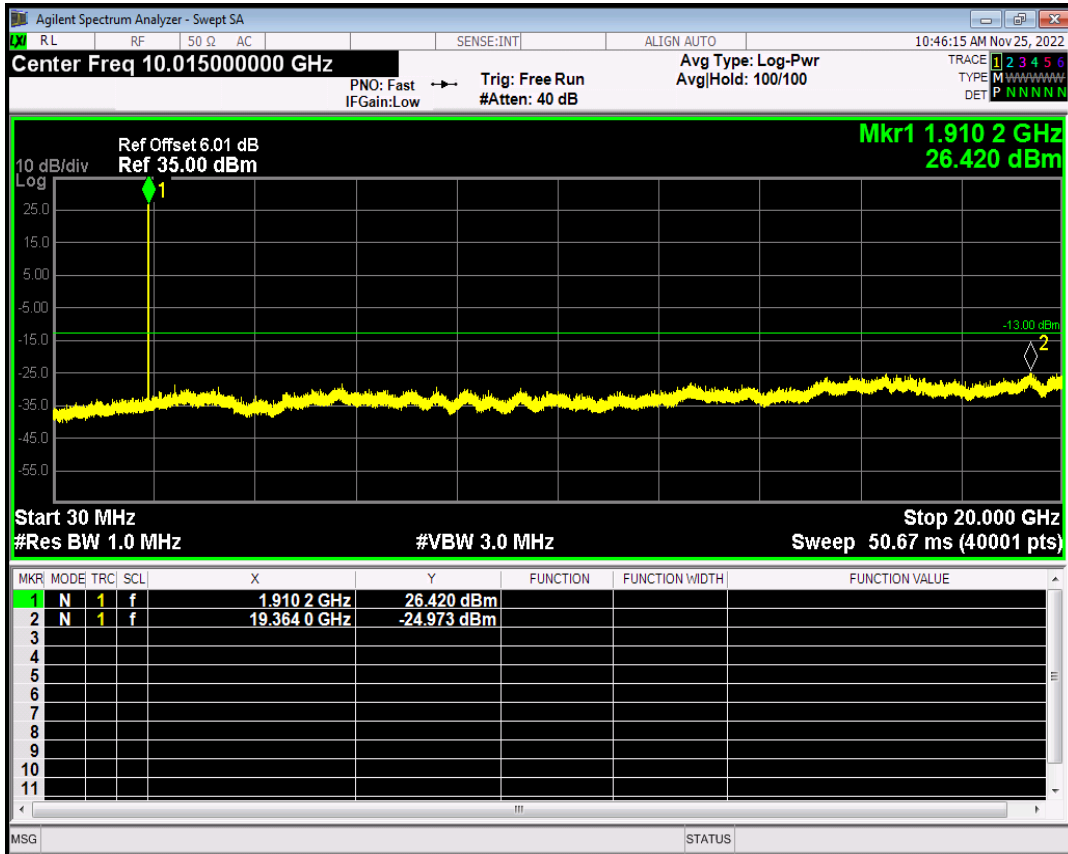
 BCTC
 3C
 PPR
 检测

GPRS1900 Channel=512

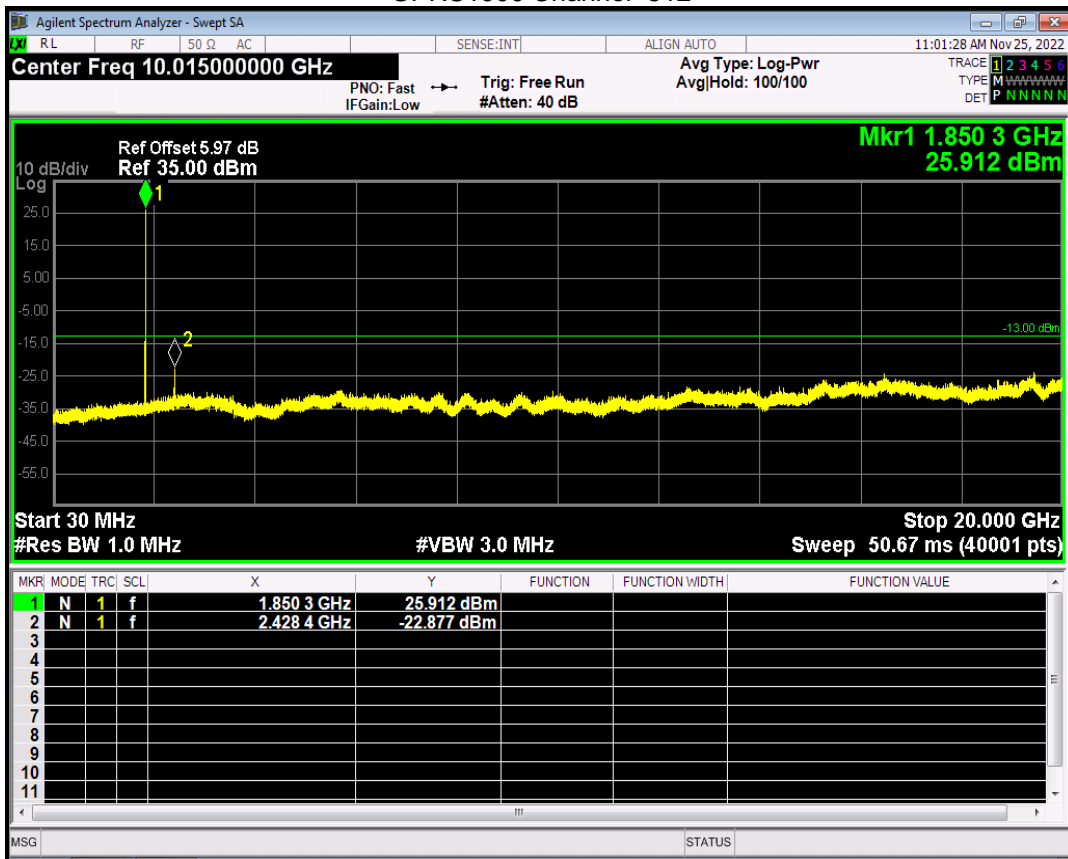

GPRS1900 Channel=661

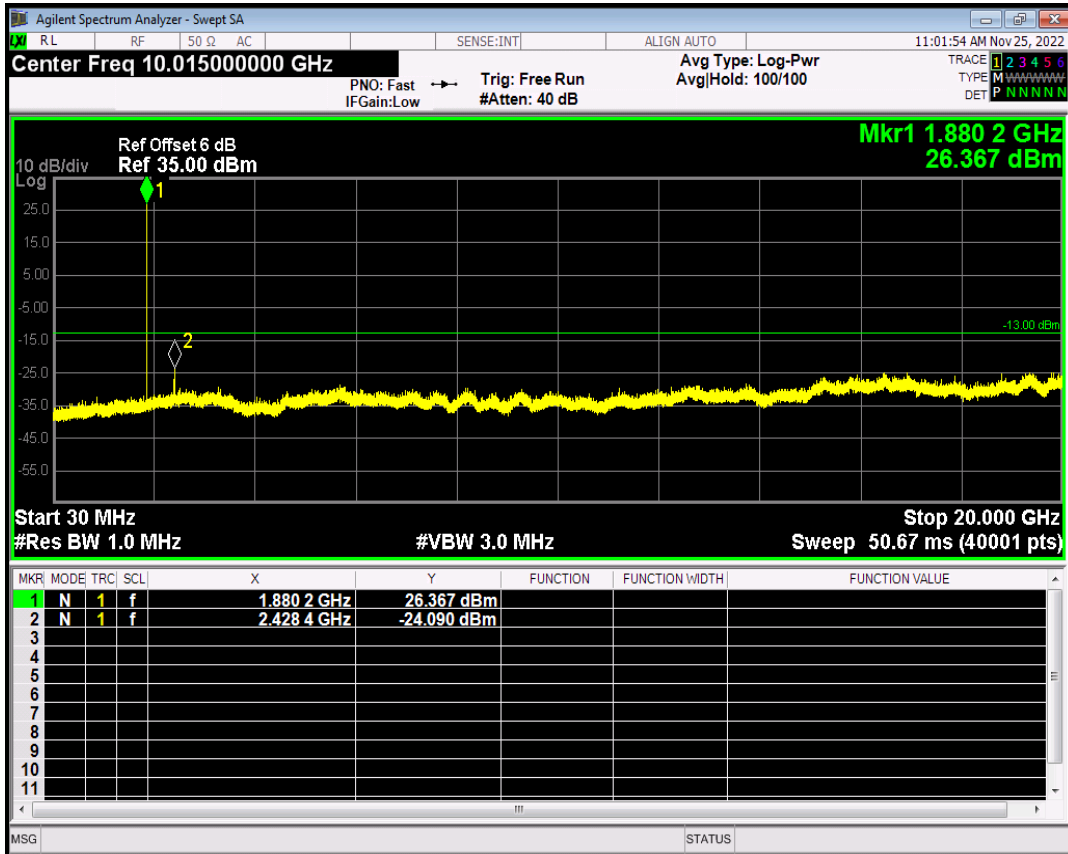

GPRS1900 Channel=810

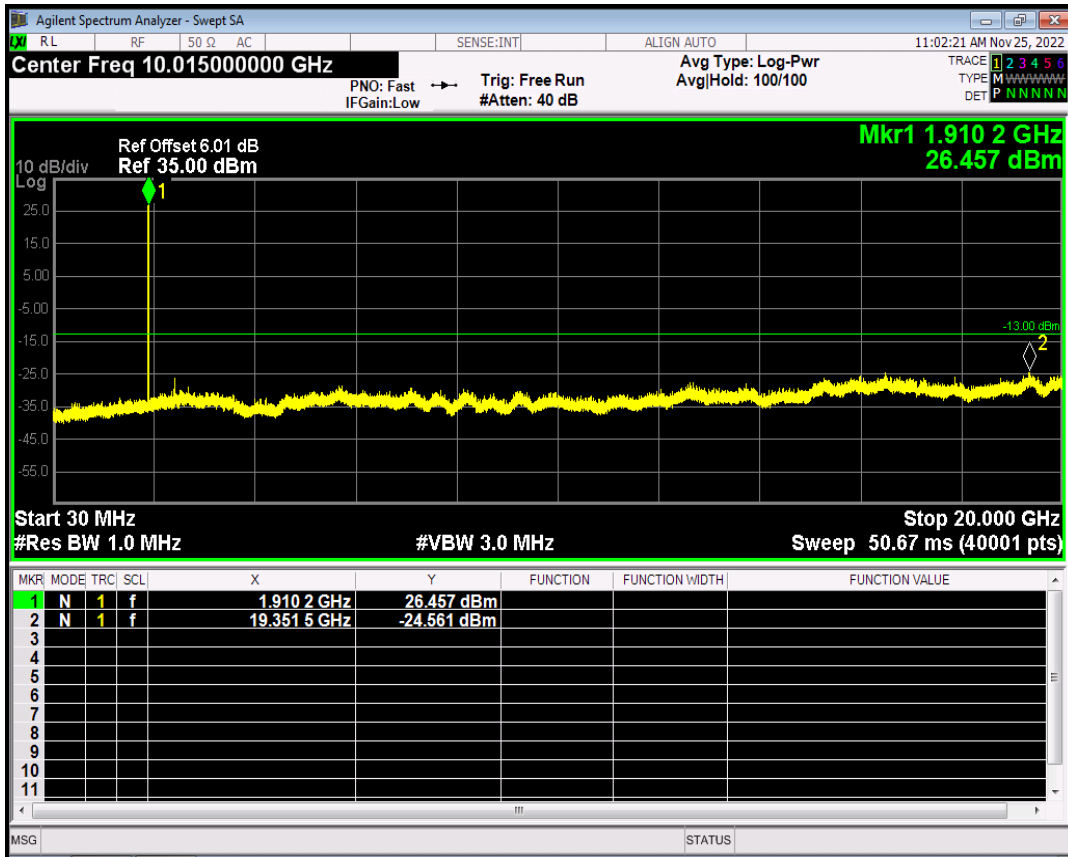

EGPRS1900 Channel=512

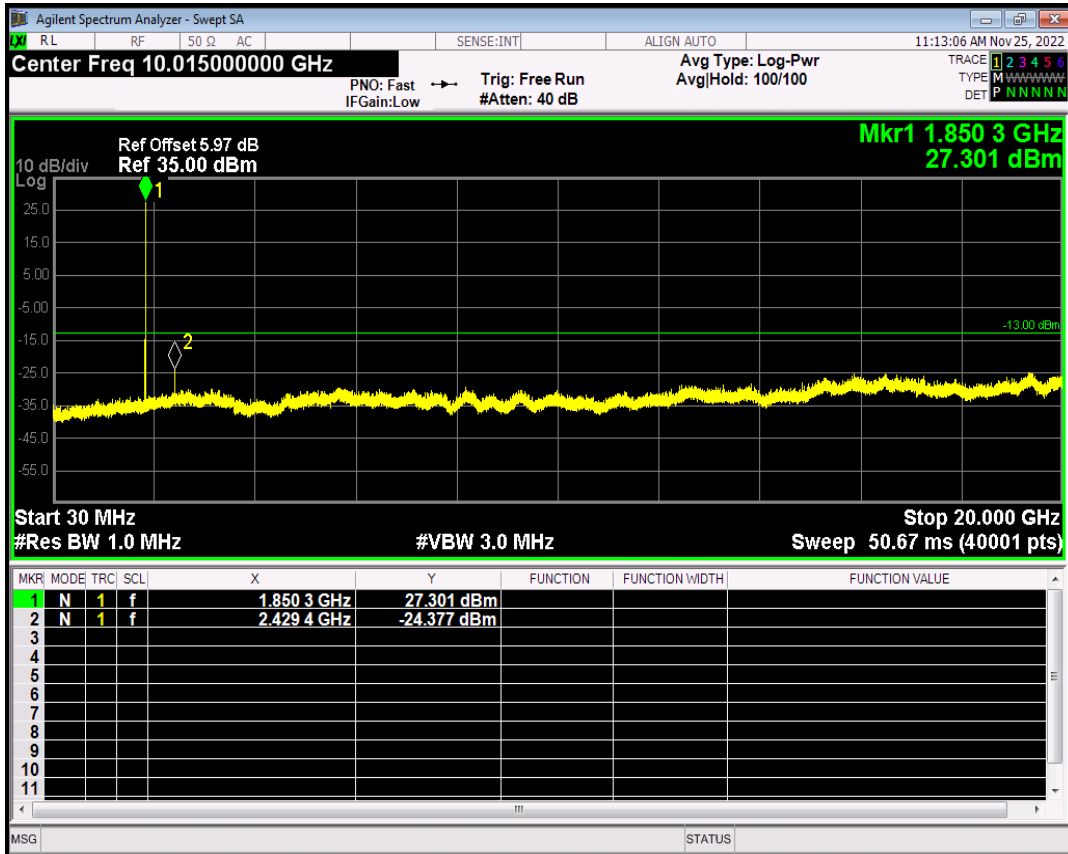

EGPRS1900 Channel=661

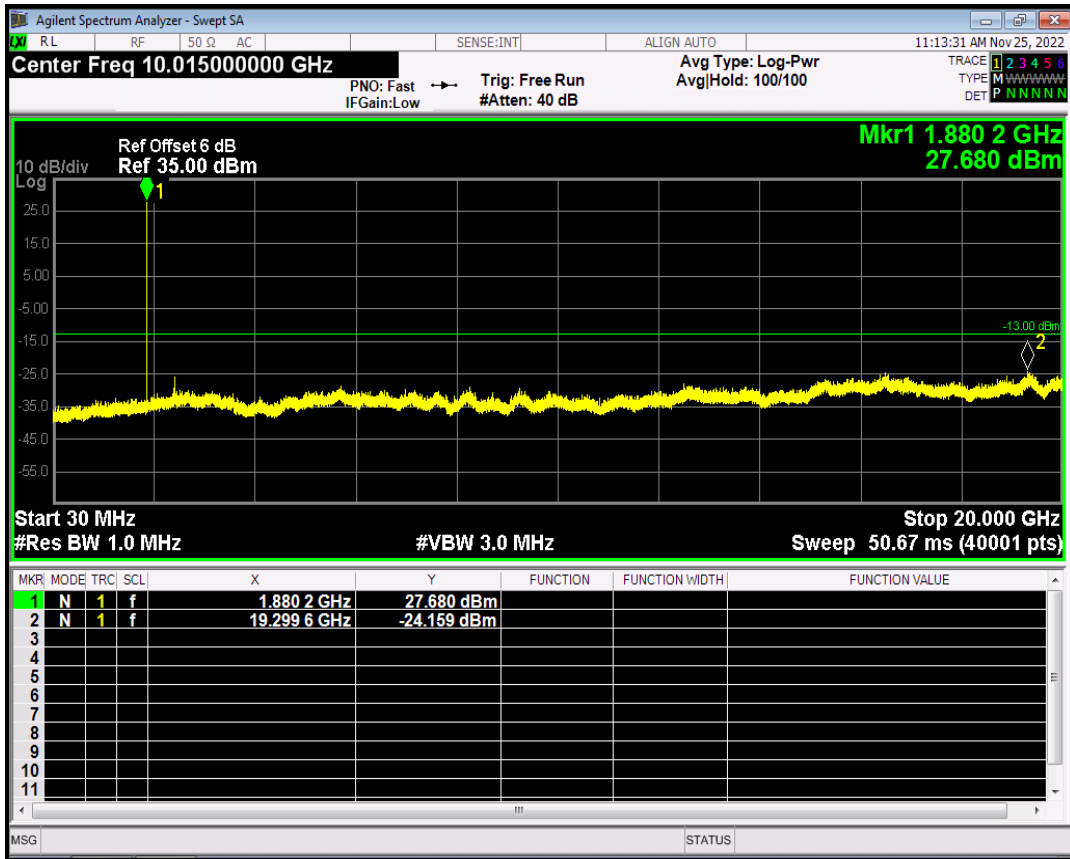

EGPRS1900 Channel=810

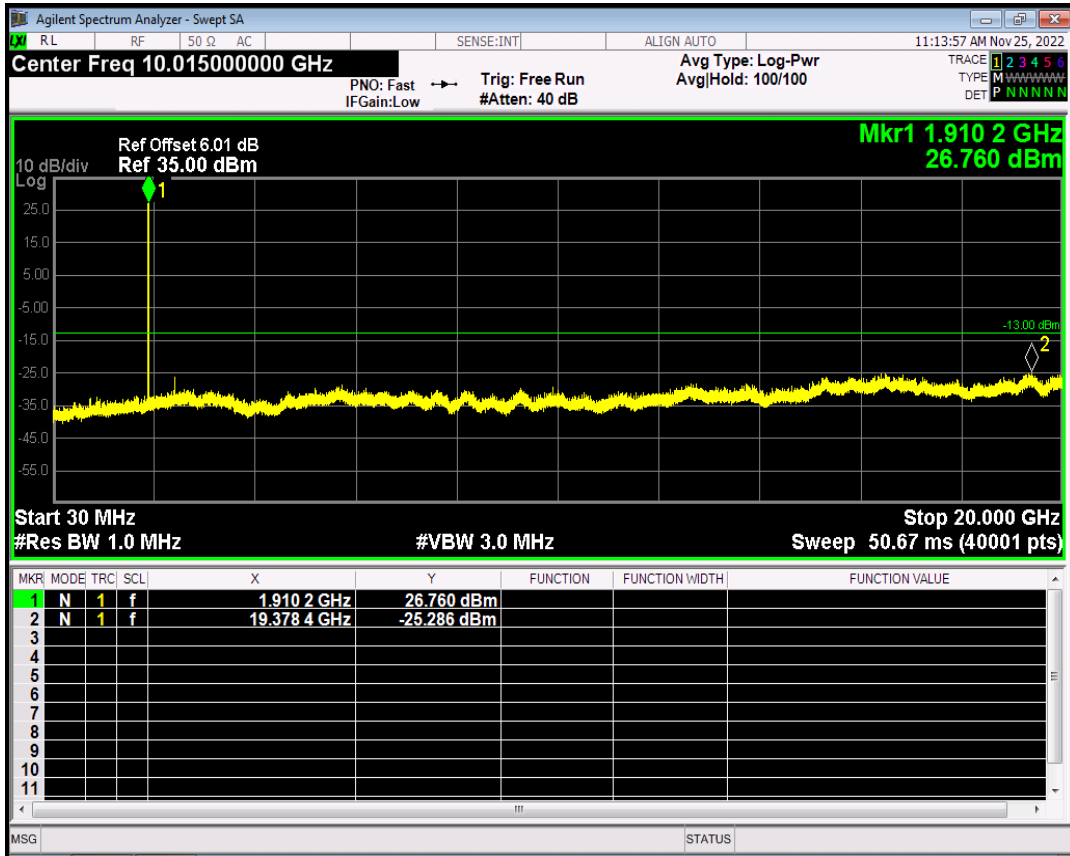

CO. LTD

Note: In WCDMA, RMC, HSDPA and HSUPA all three tests only reflect the worst mode RMC.
 WCDMA Band2 Channel=9262

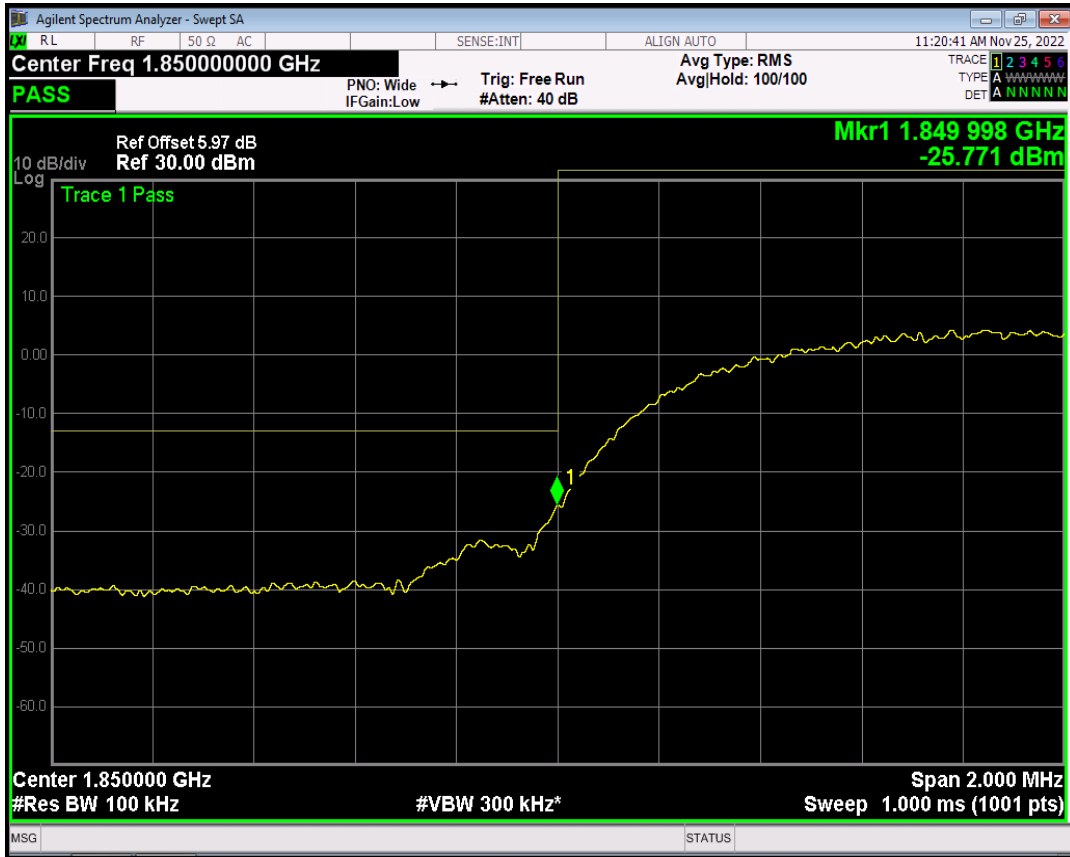

WCDMA Band2 Channel=9538



SHENZHEN

WCDMA Band4 Channel=1312

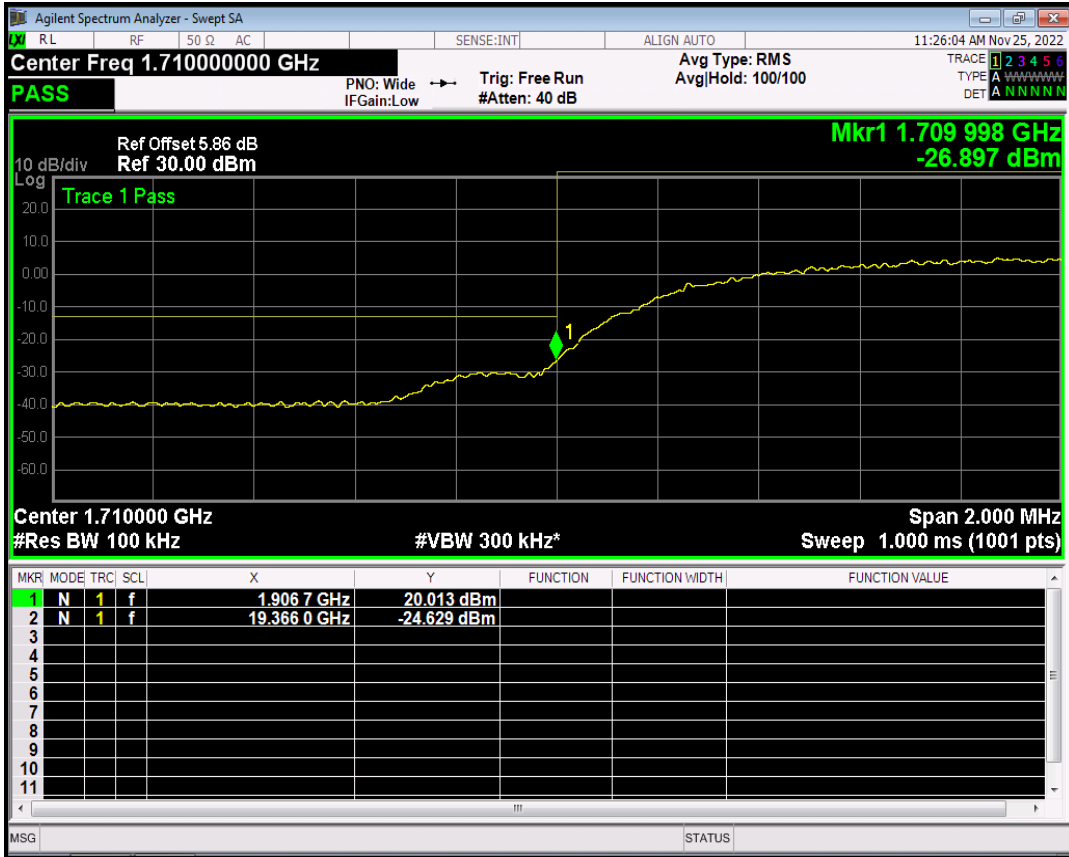

WCDMA Band4 Channel=1513

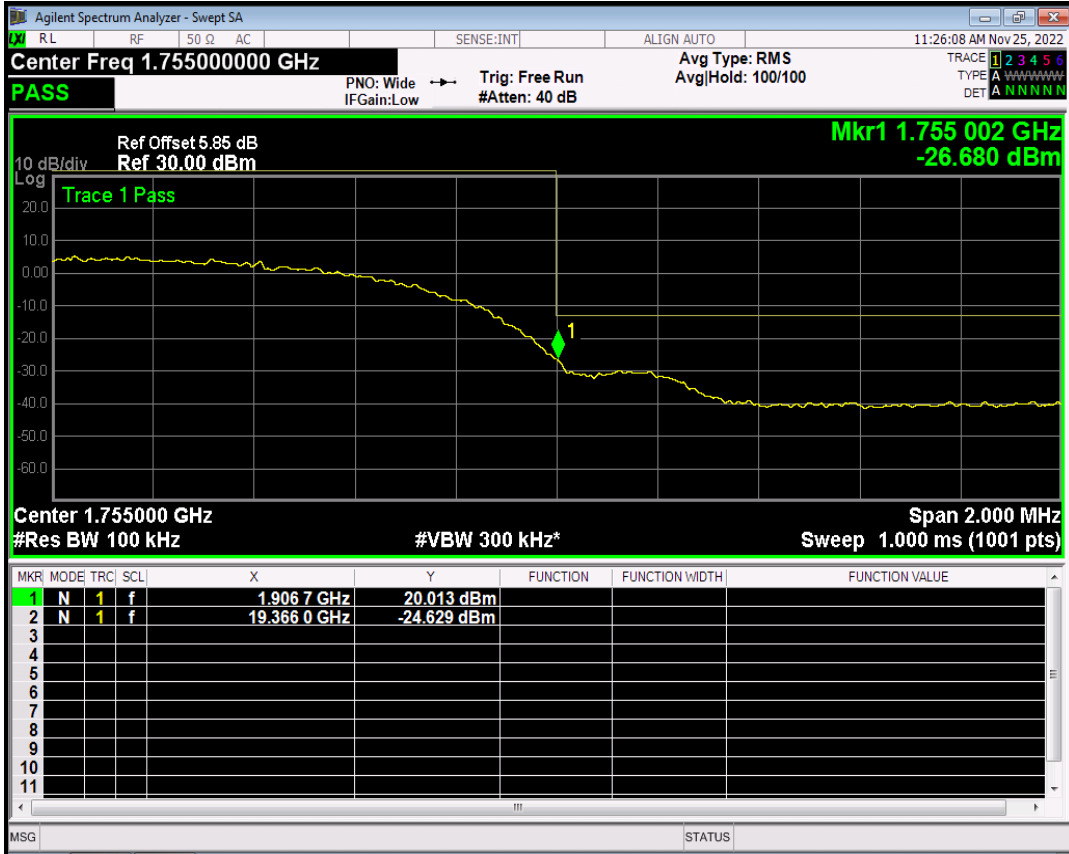

WCDMA Band5 Channel=4132

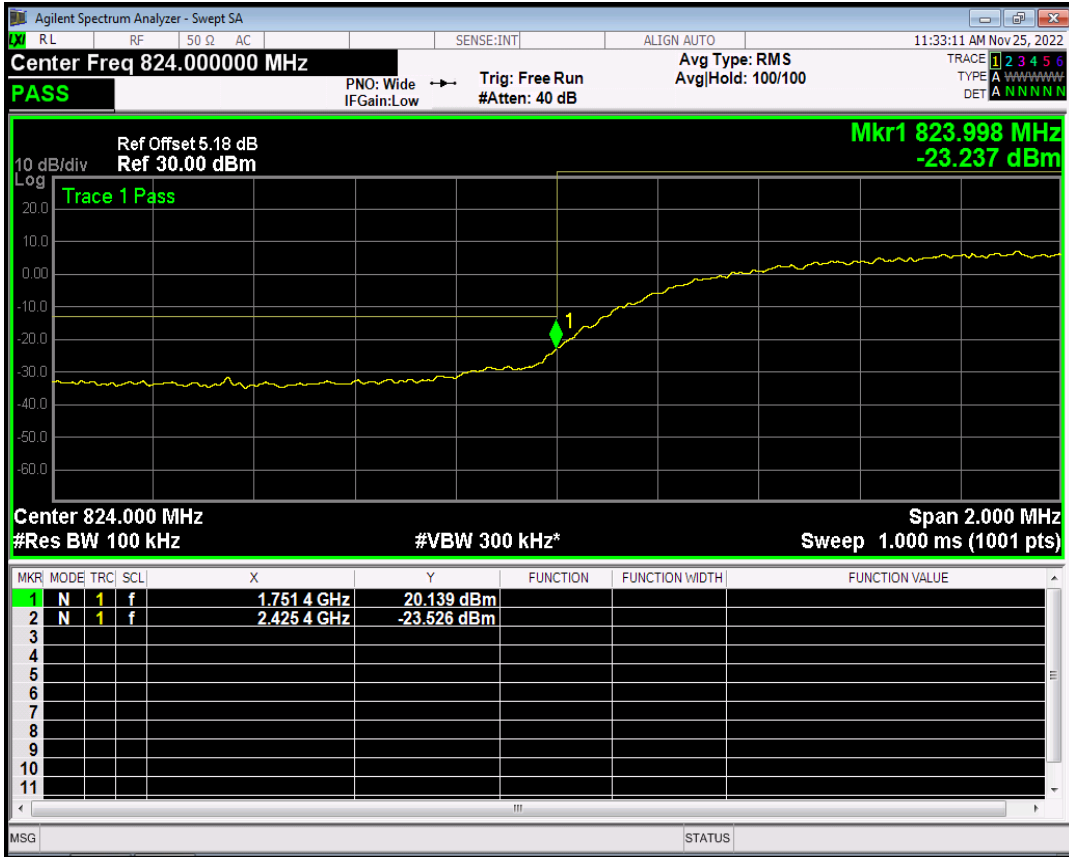

WCDMA Band5 Channel=4233

 BCTC
3C
PPR
測

WCDMA Band2 Channel=9262

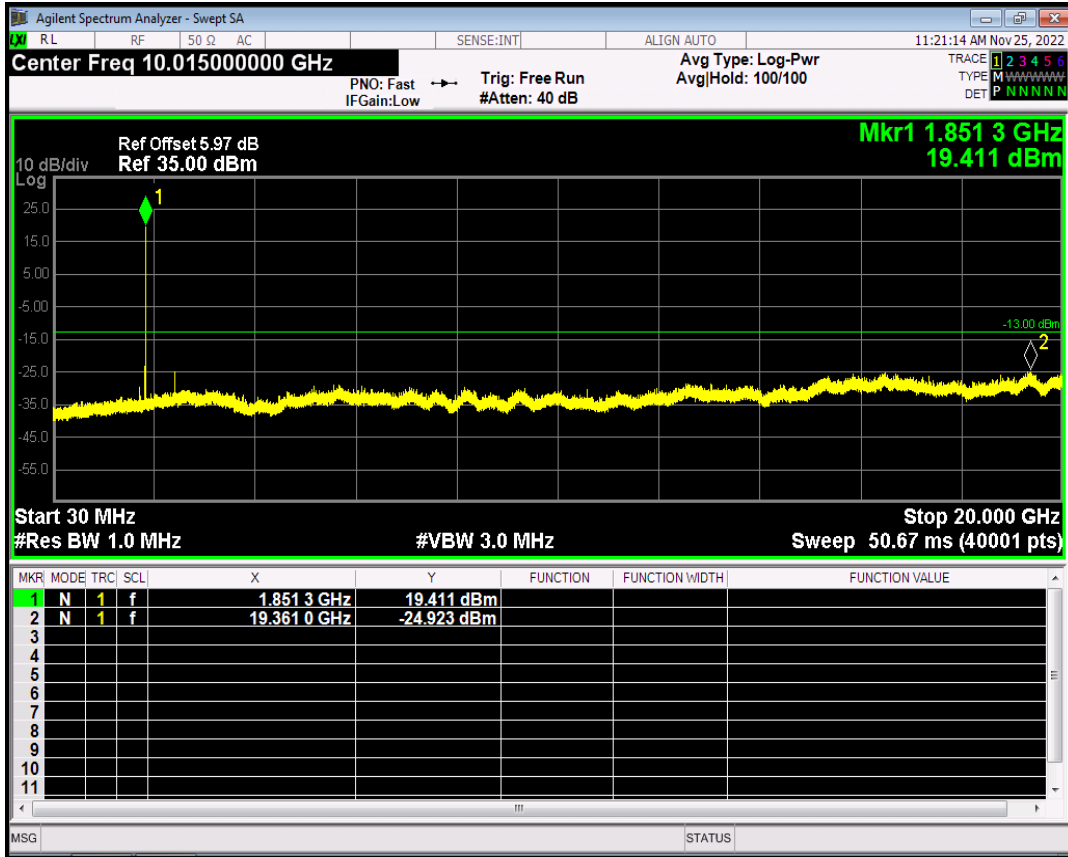

WCDMA Band2 Channel=9400

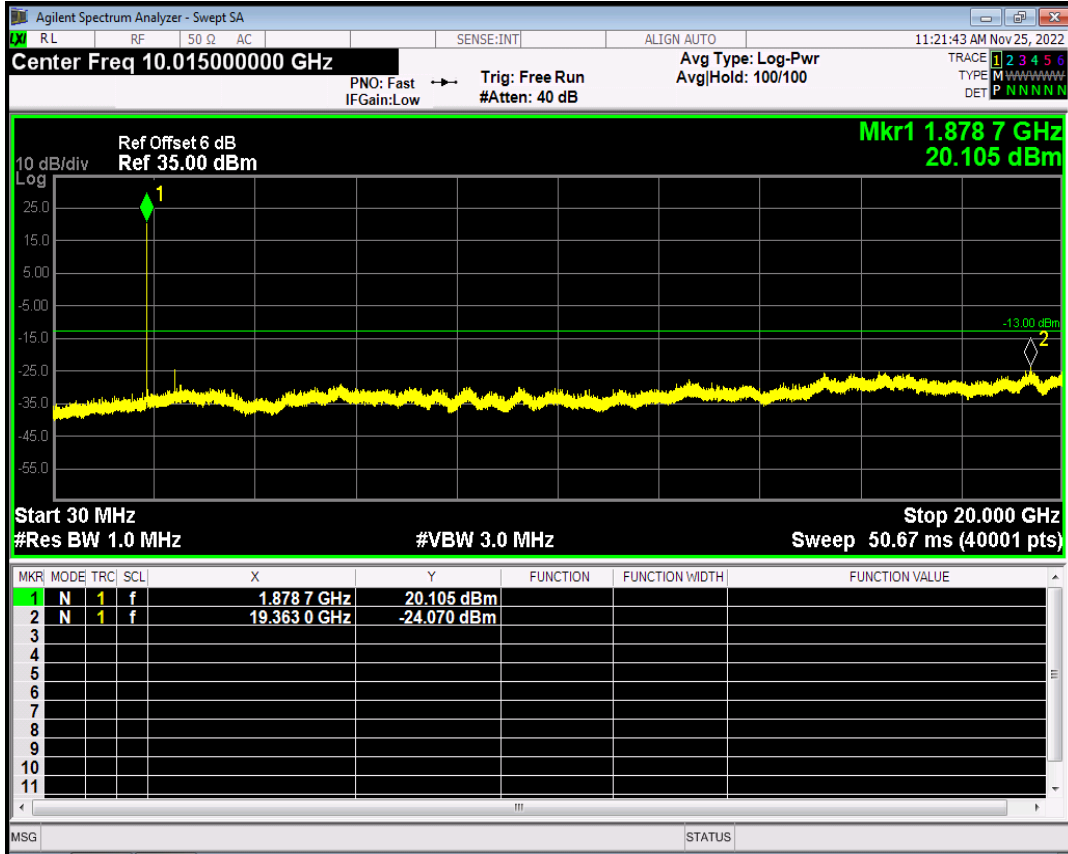

WCDMA Band2 Channel=9538

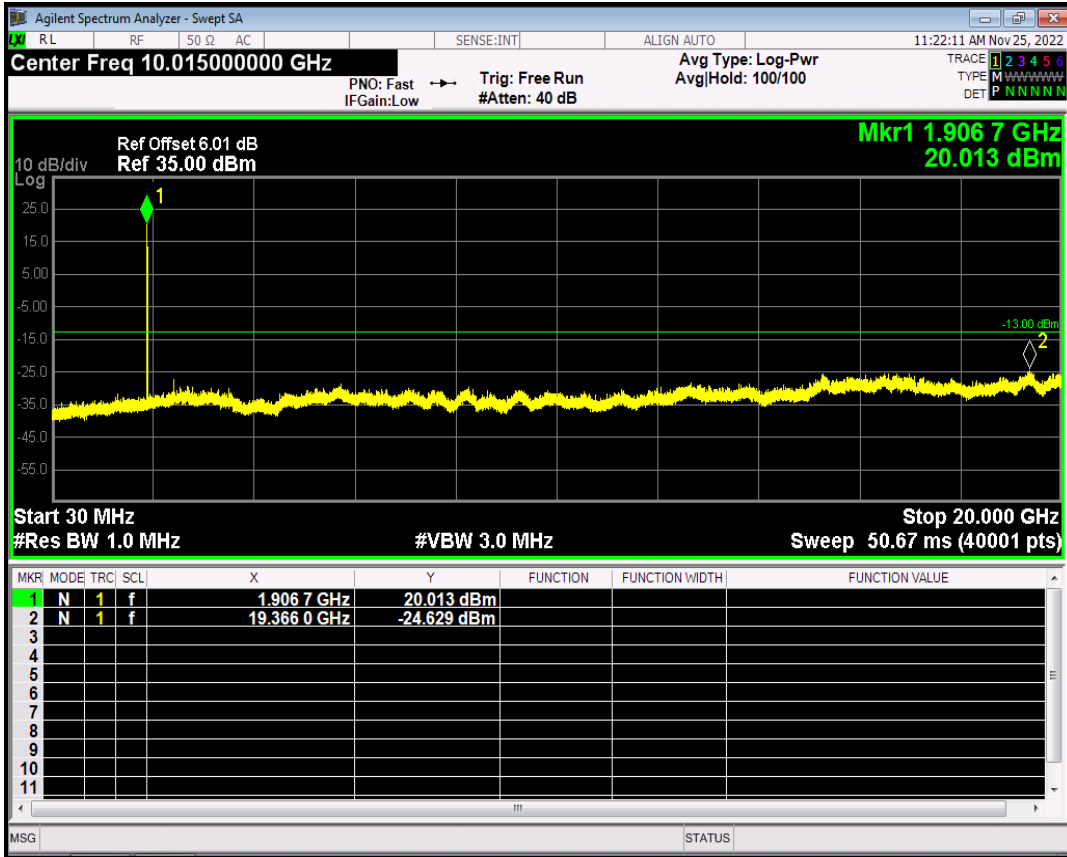

WCDMA Band4 Channel=1312

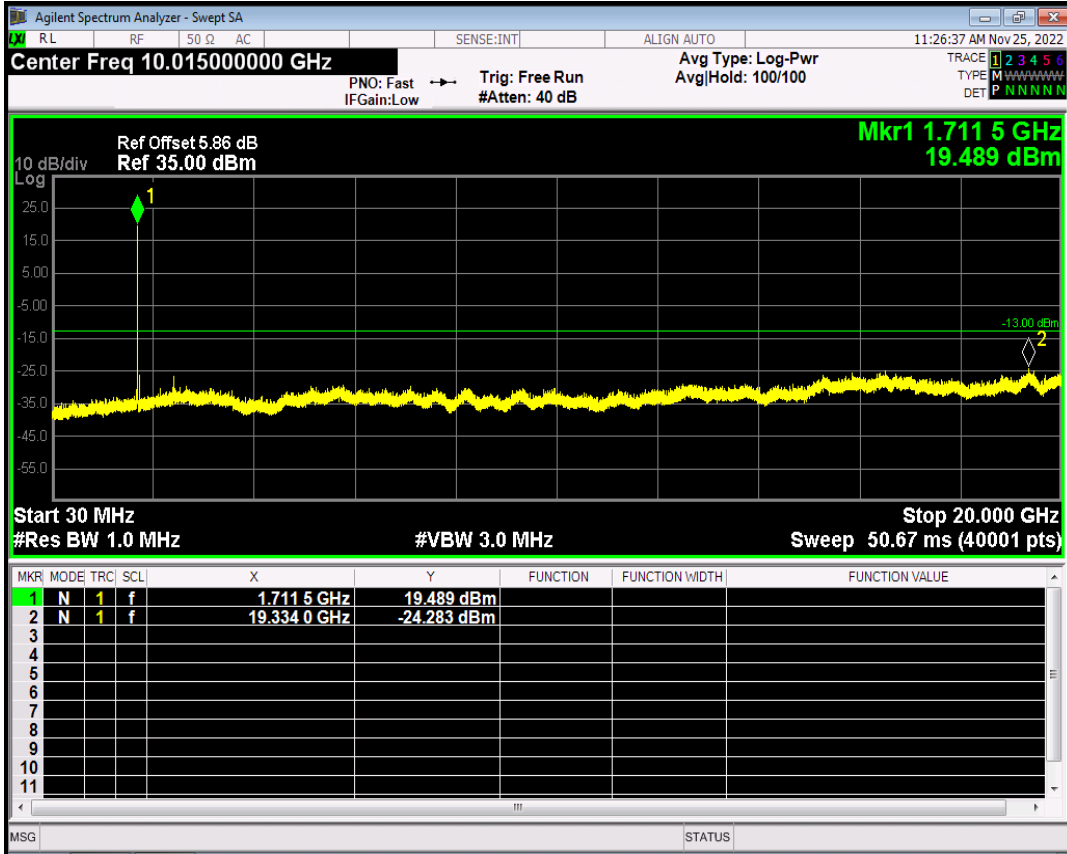

WCDMA Band4 Channel=1450

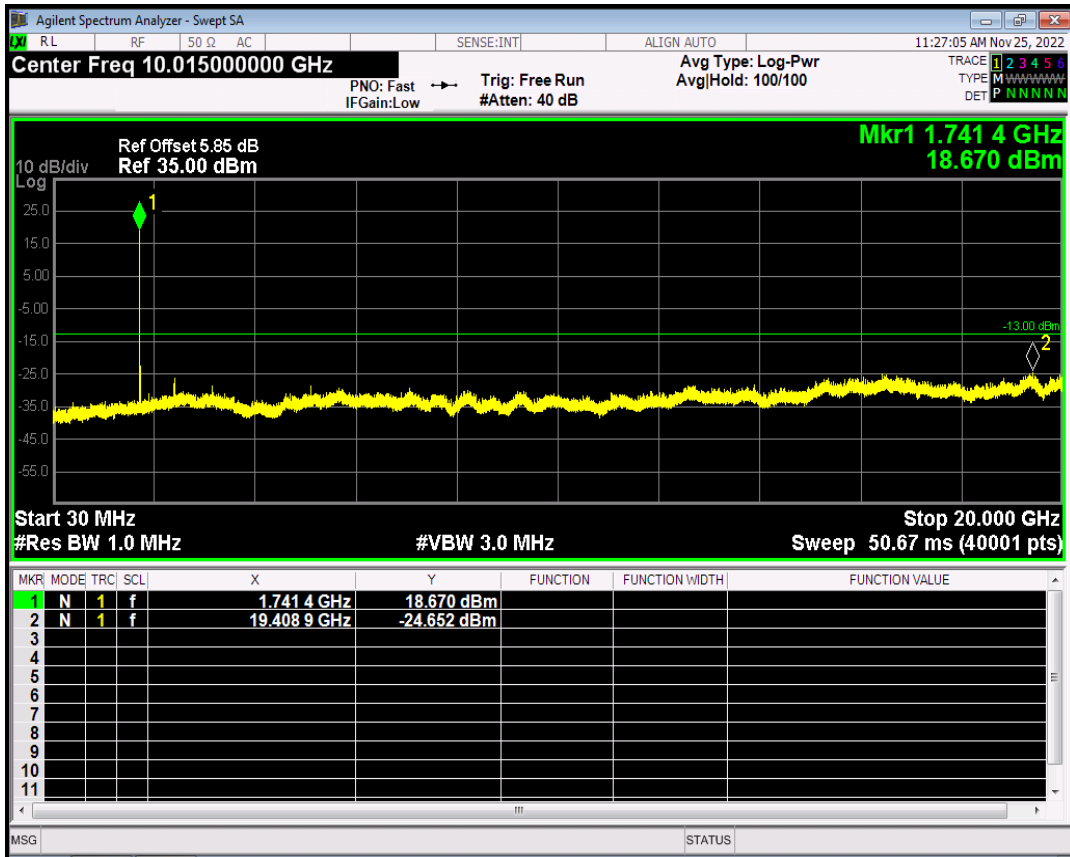

WCDMA Band4 Channel=1513

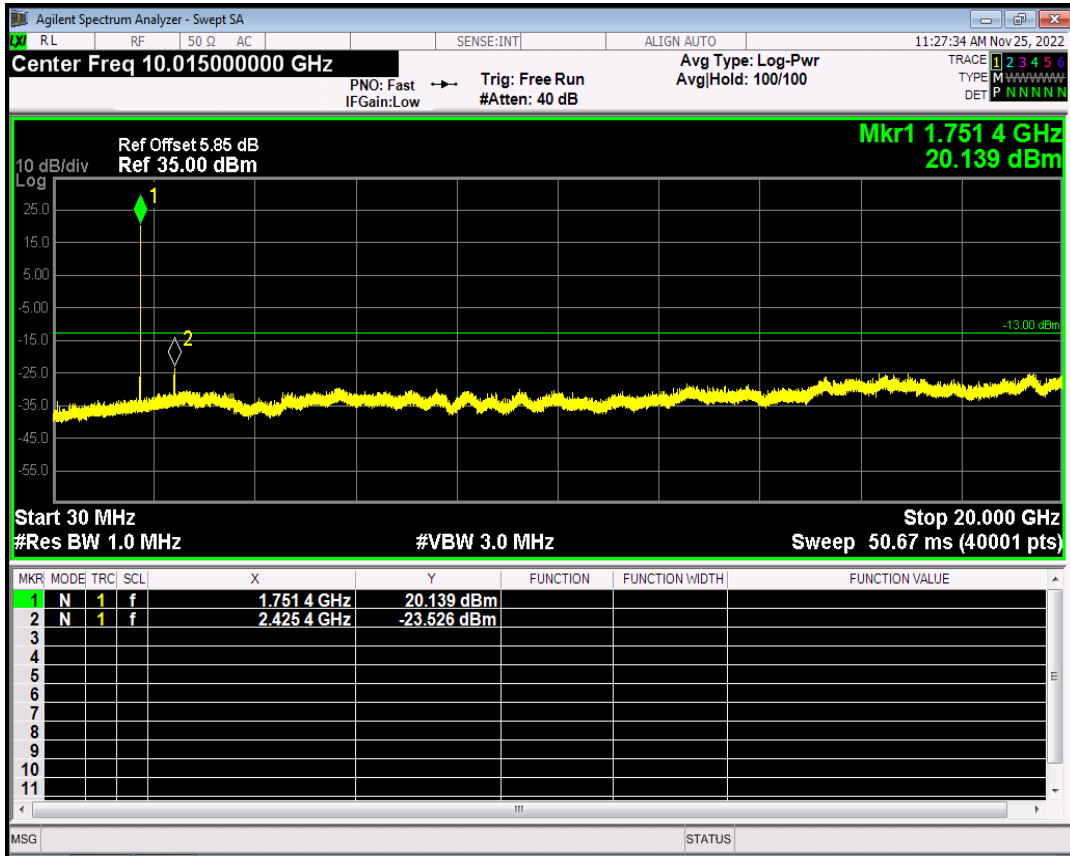

CO. LTD

WCDMA Band5 Channel=4132

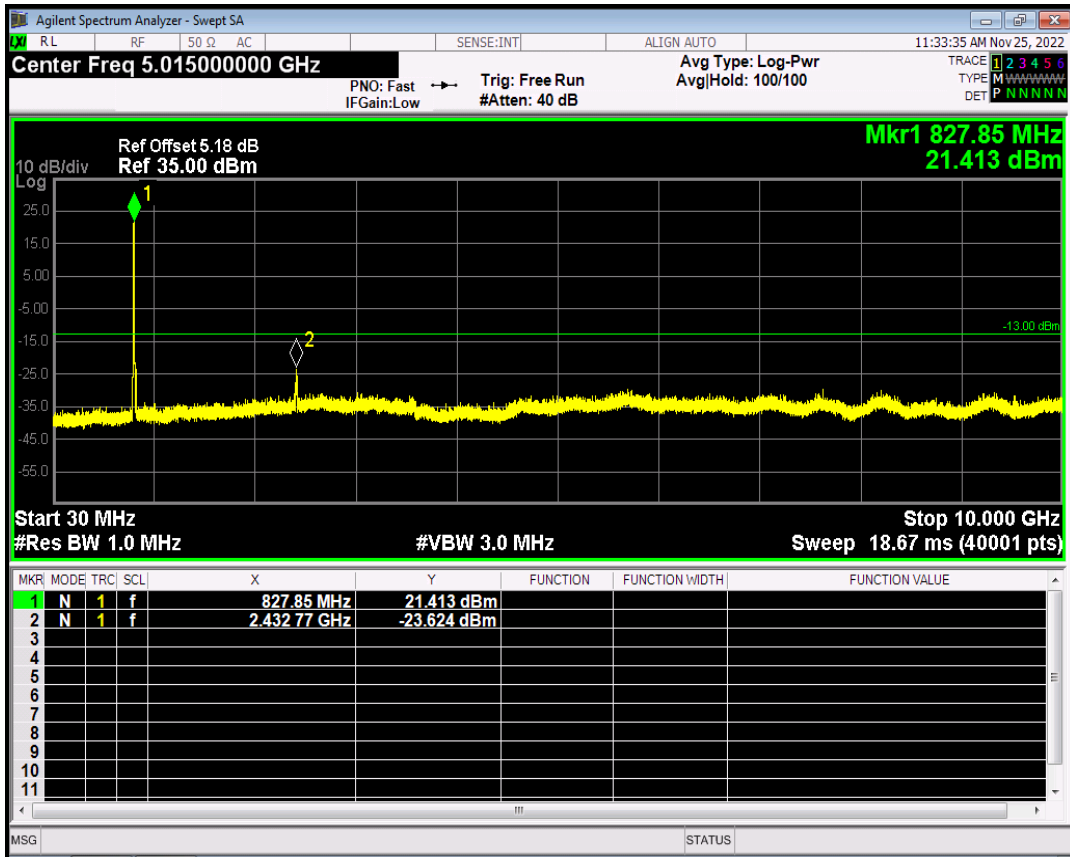

WCDMA Band5 Channel=4182

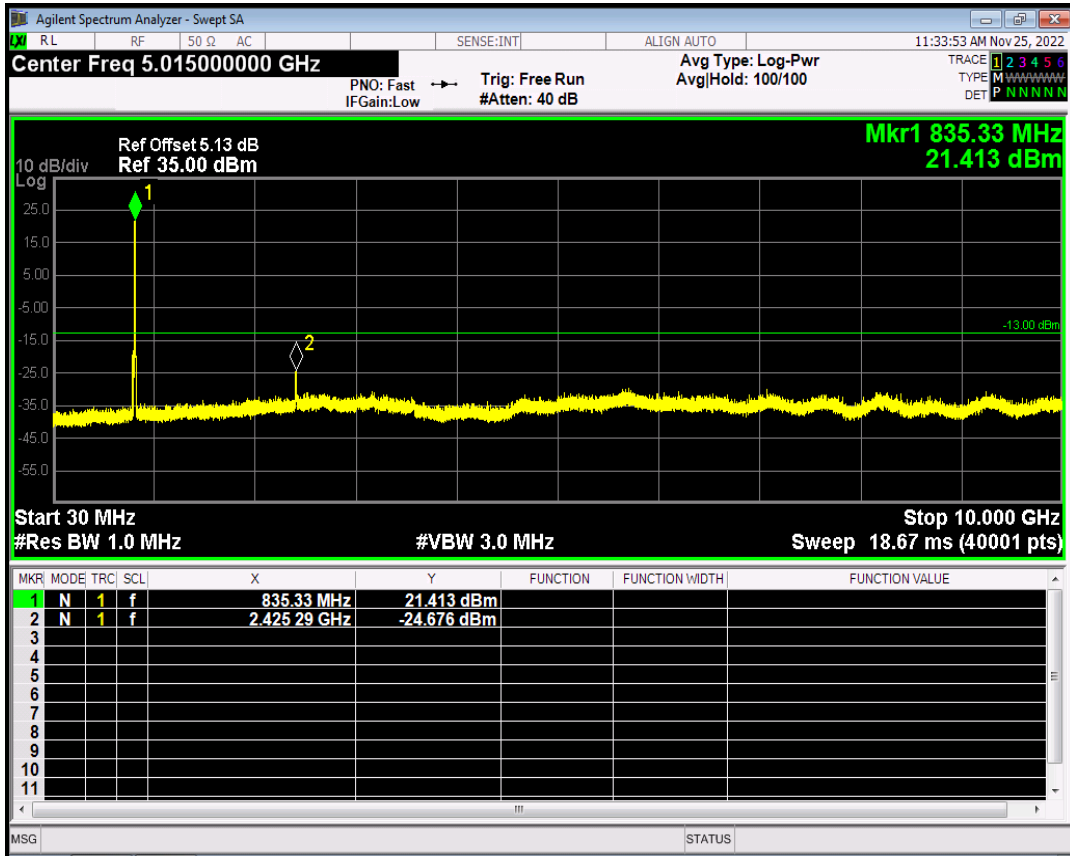

CHENZHEN

WCDMA Band5 Channel=4233

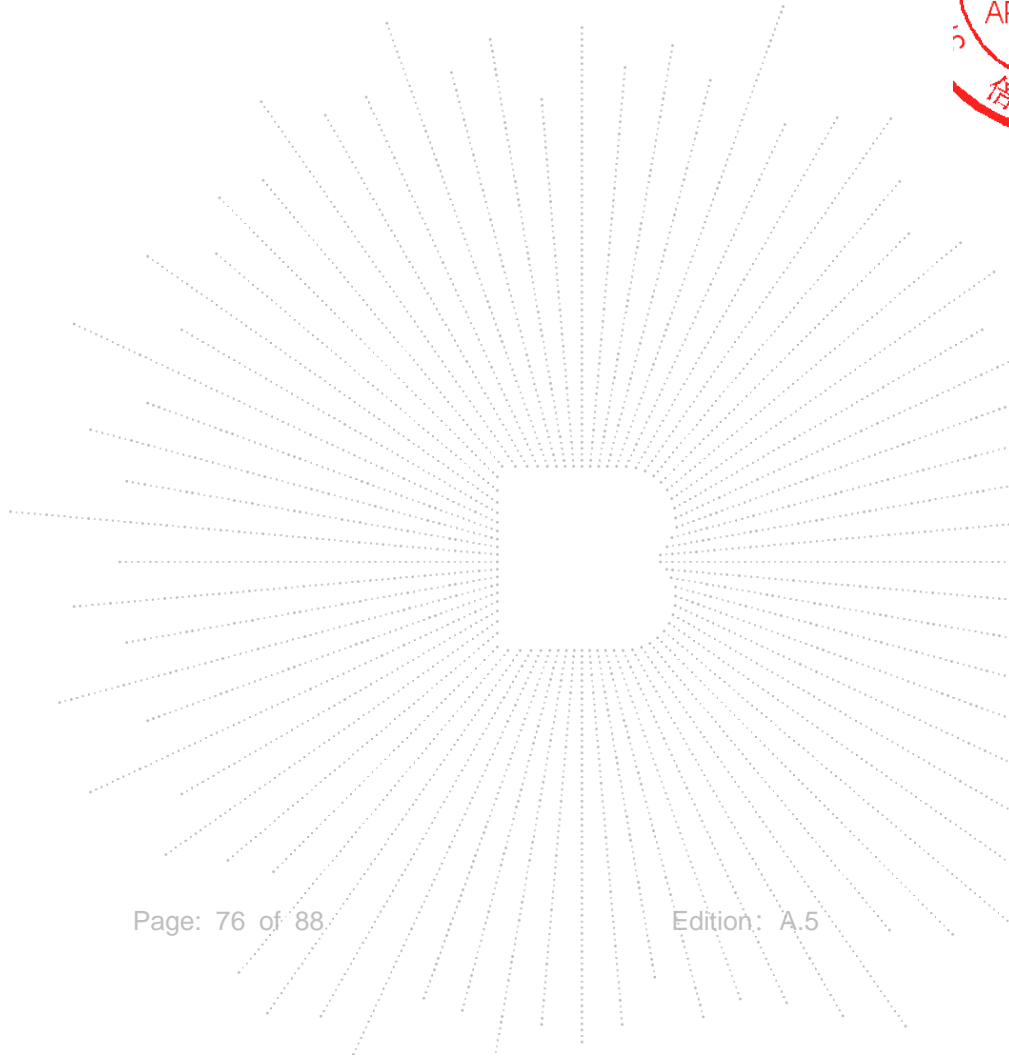
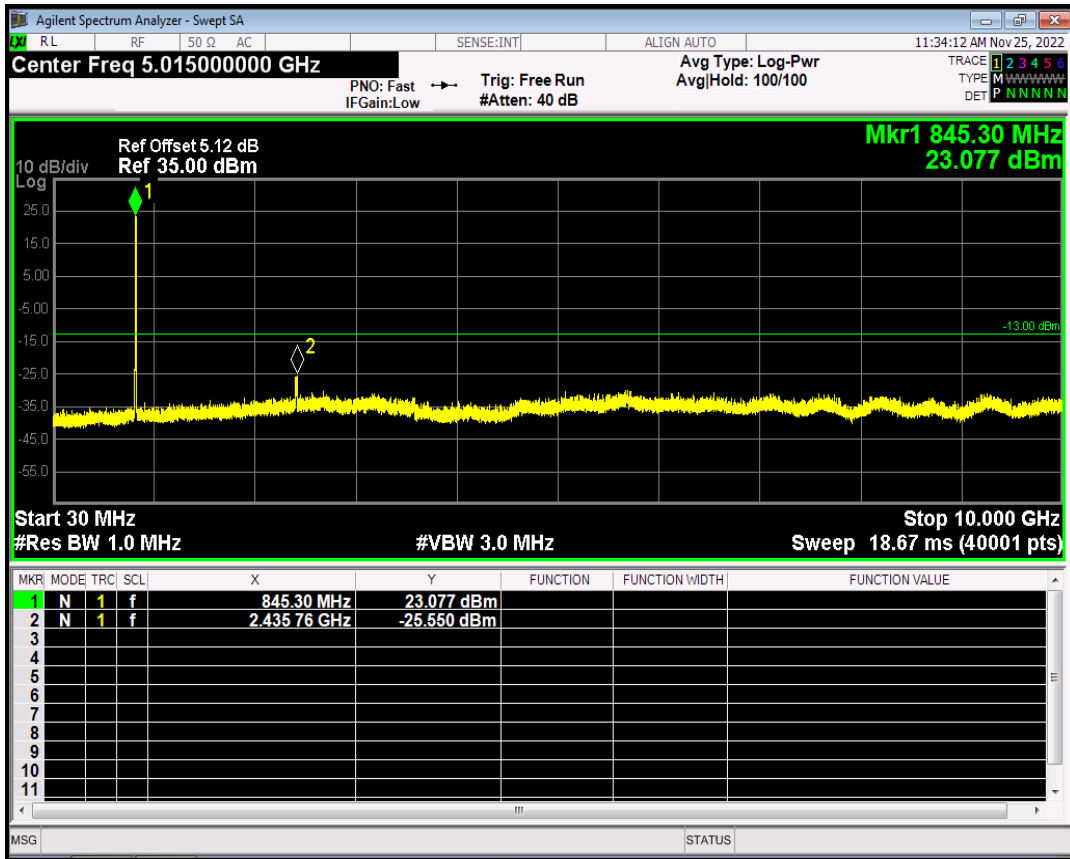

10. Spurious Radiated Emissions

10.1 Block Diagram Of Test Setup

(A) Radiated Emission Test-Up Frequency Below 30MHz

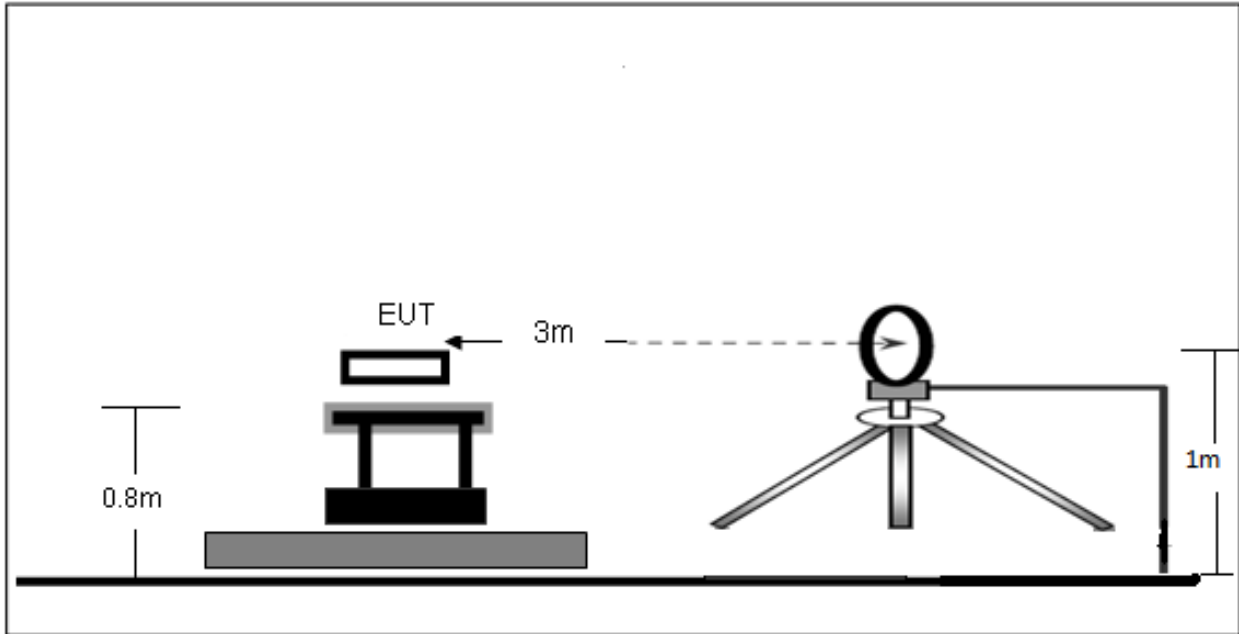

(B) Radiated Emission Test-Up Frequency 30MHz~1GHz

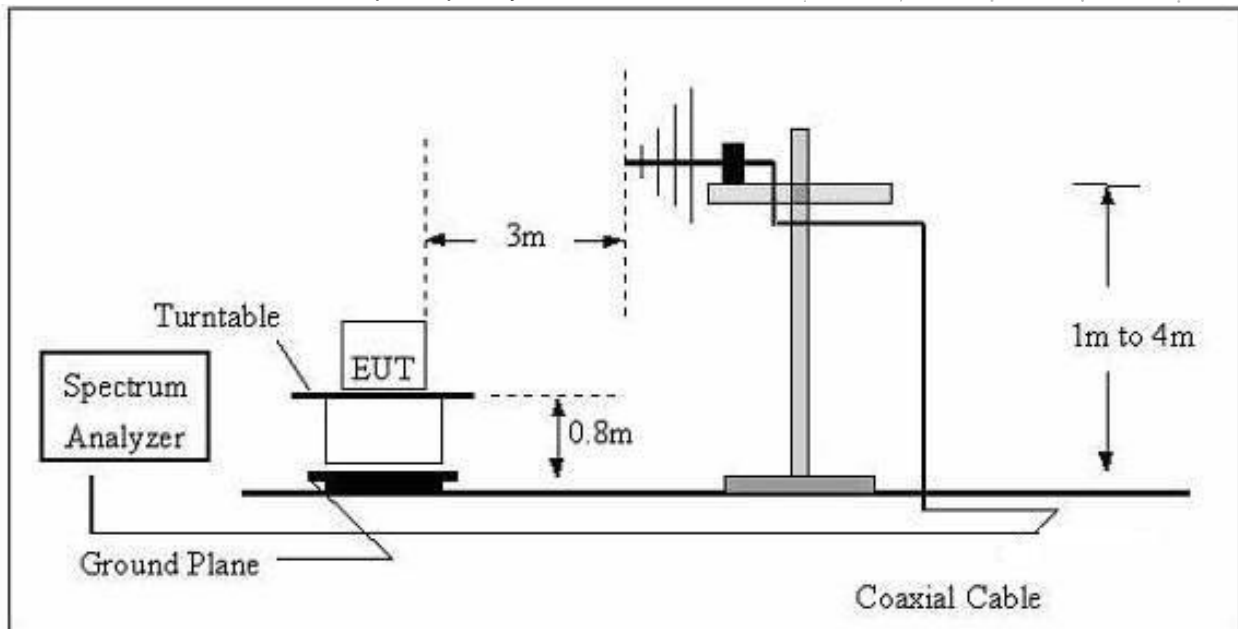

(C) Radiated Emission Test-Up Frequency Above 1GHz

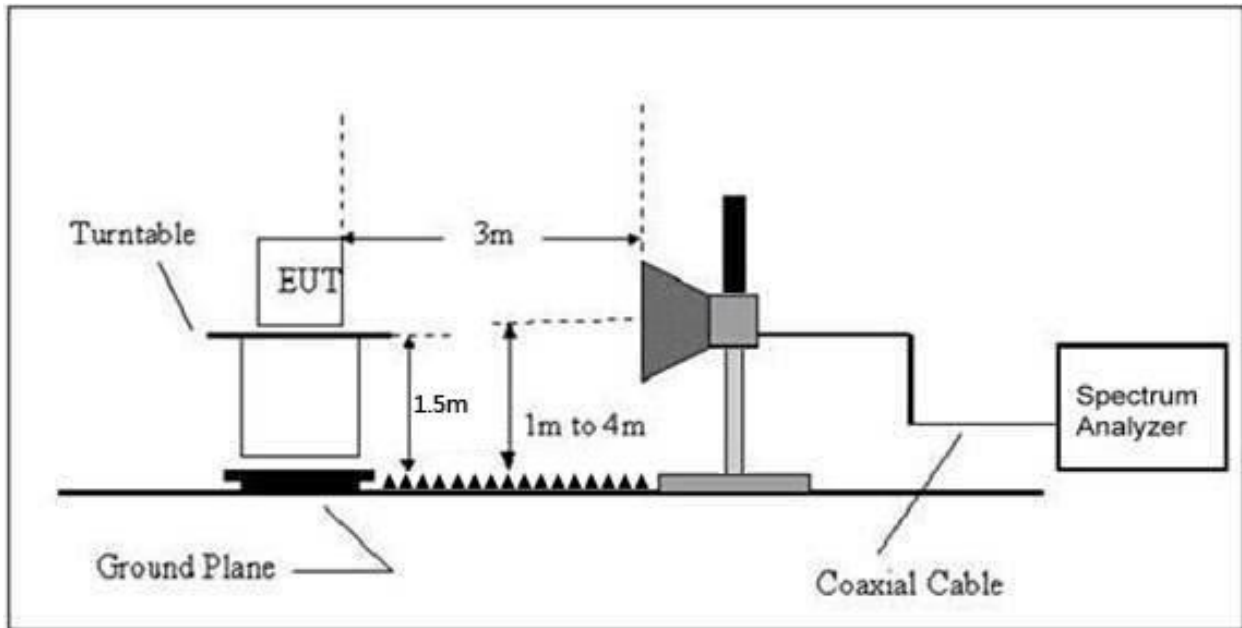

10.2 Limit

According to §22.917(a), the power of any emissions outside of the authorized operating frequency ranges must be attenuated below the transmitting power (P) by a factor of at least $43 + 10 \log(P)$ dB.

According to §24.238(a), the power of any emissions outside of the authorized operating frequency ranges must be attenuated below the transmitting power (P) by a factor of at least $43 + 10 \log(P)$ dB.

According to §27.53 (h), the power of any emission outside a licensee's frequency block shall be attenuated below the transmitter power (P) in watts by at least $43 + 10 \log_{10}(P)$ dB.

10.3 Test procedure

1. The setup of EUT is according with per ANSI/TIA Standard 603D and ANSI C63.4-2014 measurement procedure.
2. The measurement antenna was placed at a distance of 3 meters from the EUT. During the tests, the antenna height and polarization as well as EUT azimuth were varied in order to identify the maximum level of emissions from the EUT. The test was performed by placing the EUT on 3-orthogonal axis.
3. The frequency range up to tenth harmonic of the fundamental frequency was investigated.
4. Remove the EUT and replace it with substitution antenna. A signal generator was connected to the substitution antenna by a non-radiating cable. The absolute levels of the spurious emissions were measured by the substitution.

Spurious attenuation limit in dB = $43 + 10 \log_{10}(\text{power out in Watts})$

10.4 Test Result

For Cellular Band_GSM850 Mode

Frequency (MHz)	Reading (dBm)	Correct dB	Result (dBm)	Limit (dBm)	Margin (dB)	Polar H/V
Low Channel (824.2MHz)						
81.56	-44.46	-15.87	-60.33	-13.00	-47.33	H
1648.40	-21.19	-22.93	-44.12	-13.00	-31.12	H
2472.60	-24.71	-22.45	-47.16	-13.00	-34.16	H
81.56	-44.10	-15.87	-59.97	-13.00	-46.97	V
1648.40	-21.87	-22.93	-44.80	-13.00	-31.80	V
2472.60	-24.28	-22.45	-46.73	-13.00	-33.73	V
Middle Channel (836.6MHz)						
81.56	-43.15	-15.87	-59.02	-13.00	-46.02	H
1673.20	-19.83	-22.87	-42.70	-13.00	-29.70	H
2509.80	-26.50	-22.50	-49.00	-13.00	-36.00	H
81.56	-42.43	-15.87	-58.30	-13.00	-45.30	V
1673.20	-21.53	-22.87	-44.40	-13.00	-31.40	V
2509.80	-23.26	-22.50	-45.76	-13.00	-32.76	V
High Channel (848.8MHz)						
81.56	-44.45	-15.87	-60.33	-13.00	-47.33	H
1697.60	-21.99	-22.79	-44.78	-13.00	-31.78	H
2546.40	-24.63	-22.56	-47.19	-13.00	-34.19	H
81.56	-41.75	-15.87	-57.62	-13.00	-44.62	V
1697.60	-18.90	-22.79	-41.69	-13.00	-28.69	V
2546.40	-24.15	-22.56	-46.71	-13.00	-33.71	V

For PCS Band_GSM1900 Mode

Frequency (MHz)	Reading (dBm)	Correct dB	Result (dBm)	Limit (dBm)	Margin (dB)	Polar H/V
Low Channel (1850.2MHz)						
77.38	-44.36	-15.81	-60.17	-13.00	-47.17	H
3700.40	-18.44	-22.93	-41.37	-13.00	-28.37	H
5550.60	-23.46	-22.45	-45.91	-13.00	-32.91	H
77.38	-44.66	-15.81	-60.47	-13.00	-47.47	V
3700.40	-20.30	-22.93	-43.23	-13.00	-30.23	V
5550.60	-23.31	-22.45	-45.76	-13.00	-32.76	V
Middle Channel (1880MHz)						
77.38	-42.50	-15.81	-58.31	-13.00	-45.31	H
3760.00	-18.54	-22.87	-41.41	-13.00	-28.41	H
5640.00	-24.75	-22.50	-47.25	-13.00	-34.25	H
77.38	-41.14	-15.81	-56.95	-13.00	-43.95	V
3760.00	-18.54	-22.87	-41.41	-13.00	-28.41	V
5640.00	-26.03	-22.50	-48.53	-13.00	-35.53	V
High Channel (1909.8MHz)						
77.38	-42.00	-15.81	-57.81	-13.00	-44.81	H
3819.60	-21.80	-22.79	-44.59	-13.00	-31.59	H
5729.40	-24.44	-22.56	-47.00	-13.00	-34.00	H
77.38	-42.70	-15.81	-58.51	-13.00	-45.51	V
3819.60	-18.45	-22.79	-41.24	-13.00	-28.24	V
5729.40	-24.79	-22.56	-47.35	-13.00	-34.35	V



For Band WCDMA Band II Mode

Frequency (MHz)	Reading (dBm)	Correct dB	Result (dBm)	Limit (dBm)	Margin (dB)	Polar H/V
Low Channel (1852.4MHz)						
61.45	-44.83	-15.59	-60.42	-13.00	-47.42	H
3704.80	-20.36	-22.93	-43.29	-13.00	-30.29	H
5557.20	-24.38	-22.45	-46.83	-13.00	-33.83	H
61.45	-43.16	-15.59	-58.75	-13.00	-45.75	V
3704.80	-19.25	-22.93	-42.18	-13.00	-29.18	V
5557.20	-24.96	-22.45	-47.41	-13.00	-34.41	V
Middle Channel (1880MHz)						
61.45	-42.88	-15.59	-58.47	-13.00	-45.47	H
3760.00	-19.35	-22.87	-42.22	-13.00	-29.22	H
5640.00	-24.30	-22.50	-46.80	-13.00	-33.80	H
61.45	-44.65	-15.59	-60.24	-13.00	-47.24	V
3760.00	-21.68	-22.87	-44.55	-13.00	-31.55	V
5640.00	-26.47	-22.50	-48.97	-13.00	-35.97	V
High Channel (1907.6MHz)						
61.45	-43.00	-15.59	-58.59	-13.00	-45.59	H
3815.20	-18.89	-22.79	-41.68	-13.00	-28.68	H
5722.80	-24.49	-22.56	-47.05	-13.00	-34.05	H
61.45	-41.99	-15.59	-57.58	-13.00	-44.58	V
3815.20	-19.30	-22.79	-42.09	-13.00	-29.09	V
5722.80	-23.64	-22.56	-46.20	-13.00	-33.20	V

Note: Result=Reading+ Correct, Margin= Result- Limit

For Band WCDMA Band IV Mode

Frequency (MHz)	Reading (dBm)	Correct dB	Result (dBm)	Limit (dBm)	Margin (dB)	Polar H/V
Low Channel (1712.4MHz)						
88.14	-44.95	-15.96	-60.91	-13.00	-47.91	H
3424.80	-19.18	-22.93	-42.11	-13.00	-29.11	H
5137.20	-23.38	-22.45	-45.83	-13.00	-32.83	H
88.14	-41.37	-15.96	-57.33	-13.00	-44.33	V
3424.80	-20.31	-22.93	-43.24	-13.00	-30.24	V
5137.20	-25.86	-22.45	-48.31	-13.00	-35.31	V
Middle Channel (1740MHz)						
88.14	-43.45	-15.96	-59.41	-13.00	-46.41	H
3480.00	-18.99	-22.87	-41.86	-13.00	-28.86	H
5220.00	-23.34	-22.50	-45.84	-13.00	-32.84	H
88.14	-41.23	-15.96	-57.19	-13.00	-44.19	V
3480.00	-20.16	-22.87	-43.03	-13.00	-30.03	V
5220.00	-25.31	-22.50	-47.81	-13.00	-34.81	V
High Channel (1752.6MHz)						
88.14	-44.74	-15.96	-60.70	-13.00	-47.70	H
3505.20	-21.63	-22.79	-44.42	-13.00	-31.42	H
5257.80	-25.34	-22.56	-47.90	-13.00	-34.90	H
88.14	-44.37	-15.96	-60.33	-13.00	-47.33	V
3505.20	-19.51	-22.79	-42.30	-13.00	-29.30	V
5257.80	-26.35	-22.56	-48.91	-13.00	-35.91	V

Note: Result=Reading+ Correct, Margin= Result- Limit

For Band WCDMA Band V Mode

Frequency (MHz)	Reading (dBm)	Correct dB	Result (dBm)	Limit (dBm)	Margin (dB)	Polar H/V
Low Channel (826.4MHz)						
66.25	-43.39	-15.66	-59.05	-13.00	-46.05	H
1652.80	-18.96	-22.93	-41.89	-13.00	-28.89	H
2479.20	-26.99	-22.45	-49.44	-13.00	-36.44	H
66.25	-41.40	-15.66	-57.06	-13.00	-44.06	V
1652.80	-20.96	-22.93	-43.89	-13.00	-30.89	V
2479.20	-26.29	-22.45	-48.74	-13.00	-35.74	V
Middle Channel (836.4MHz)						
66.25	-44.87	-15.66	-60.52	-13.00	-47.52	H
1672.80	-19.25	-22.87	-42.12	-13.00	-29.12	H
2509.20	-24.26	-22.50	-46.76	-13.00	-33.76	H
66.25	-43.47	-15.66	-59.13	-13.00	-46.13	V
1672.80	-19.25	-22.87	-42.12	-13.00	-29.12	V
2509.20	-23.62	-22.50	-46.12	-13.00	-33.12	V
High Channel (846.6MHz)						
66.25	-42.69	-15.66	-58.35	-13.00	-45.35	H
1693.20	-19.84	-22.79	-42.63	-13.00	-29.63	H
2539.80	-26.47	-22.56	-49.03	-13.00	-36.03	H
66.25	-41.57	-15.66	-57.23	-13.00	-44.23	V
1693.20	-20.55	-22.79	-43.34	-13.00	-30.34	V
2539.80	-26.63	-22.56	-49.19	-13.00	-36.19	V

Note: Result=Reading+ Correct, Margin= Result- Limit

Note: Testing is carried out with frequency rang 9kHz to the tenth harmonics, other than listed in the table above are attenuated more than 20dB below the permissible limits or the field strength is too small to be measured.

11. Frequency Stability

11.1 Block Diagram Of Test Setup

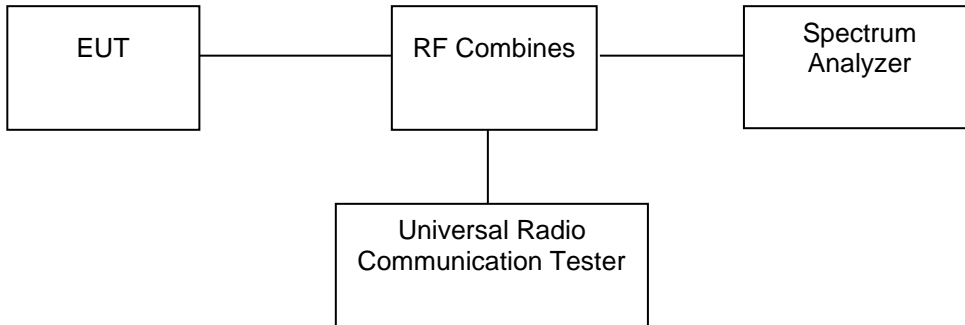

11.2 Limit

FCC Part 22.355 : ± 2.5 ppm

FCC Part 24.235 :

The frequency stability shall be sufficient to ensure that the fundamental emission stays within the authorized frequency block.

11.3 Test procedure

1. The testing follows FCC KDB 971168 D01v03r01 Section 9.0.
2. The EUT was set up in the thermal chamber and connected with the system simulator.
3. With power OFF, the temperature was decreased to -30°C and the EUT was stabilized before testing. Power was applied and the maximum change in frequency was recorded within one minute.
4. With power OFF, the temperature was raised in 10°C steps up to 50°C . The EUT was stabilized at each step for at least half an hour. Power was applied and the maximum frequency change was recorded within one minute.

Test Procedures for Voltage Variation

1. The testing follows FCC KDB 971168 D01v03r01 Section 9.0.
2. The EUT was placed in a temperature chamber at $25 \pm 5^{\circ}\text{C}$ and connected with the system simulator.
3. The power supply voltage to the EUT was varied from BEP to 115% of the nominal value measured at the input to the EUT.
4. The variation in frequency was measured for the worst case.

11.4 Test Result

Operation Mode	Channel Number	Test Condition		Channel Frequency (MHz)	Freq.Dev. (Hz)	Deviation (ppm)	Limit (ppm)
		Voltage (V)	Temp (°C)				
GSM850	190	VN	-20	836.60	-2.89	-0.0034	2.5
			-10	836.60	0.39	0.0005	2.5
			0	836.60	-1.79	-0.0021	2.5
			10	836.60	-5.07	-0.0061	2.5
			20	836.60	6.59	0.0079	2.5
			30	836.60	5.98	0.0072	2.5
			40	836.60	7.05	0.0084	2.5
			50	836.60	3.04	0.0036	2.5
		VL	20	836.60	5.01	0.0060	2.5
		VH	20	836.60	7.45	0.0089	2.5
VERDICT				PASS			

Operation Mode	Channel Number	Test Condition		Channel Frequency (MHz)	Freq.Dev. (Hz)	Deviation (ppm)	Limit (ppm)
		Voltage (V)	Temp (°C)				
GSM1900	512	VN	-20	1850.20	14.42	0.0078	2.5
			-10	1850.20	18.70	0.0101	2.5
			0	1850.20	15.37	0.0083	2.5
			10	1850.20	17.29	0.0093	2.5
			20	1850.20	17.27	0.0093	2.5
			30	1850.20	16.13	0.0087	2.5
			40	1850.20	17.11	0.0092	2.5
			50	1850.20	13.94	0.0075	2.5
		VL	20	1850.20	15.46	0.0084	2.5
		VH	20	1850.20	17.10	0.0092	2.5
VERDICT				PASS			

Note: All modes have been tested with GSM

 BCTC
 B
 AP
 停

All modes have been tested, and the worst result recorded was report as below

Operation Mode	Channel Number	Test Condition		Channel Frequency (MHz)	Freq.Dev. (Hz)	Deviation (ppm)	Limit (ppm)
		Voltage (V)	Temp (°C)				
WCDMA850	4132	VN	-20	836.40	14.34	0.0171	2.5
			-10	836.40	18.70	0.0224	2.5
			0	836.40	15.15	0.0181	2.5
			10	836.40	17.21	0.0206	2.5
			20	836.40	17.29	0.0207	2.5
			30	836.40	16.16	0.0193	2.5
			40	836.40	17.16	0.0205	2.5
			50	836.40	13.82	0.0165	2.5
		VL	20	836.40	15.48	0.0185	2.5
		VH	20	836.40	17.15	0.0205	2.5
VERDICT				PASS			

Operation Mode	Channel Number	Test Condition		Channel Frequency (MHz)	Freq.Dev. (Hz)	Deviation (ppm)	Limit (ppm)
		Voltage (V)	Temp (°C)				
WCDMA1700	1312	VN	-20	1712.40	14.45	0.0084	2.5
			-10	1712.40	18.73	0.0109	2.5
			0	1712.40	15.21	0.0089	2.5
			10	1712.40	17.22	0.0101	2.5
			20	1712.40	17.34	0.0101	2.5
			30	1712.40	16.08	0.0094	2.5
			40	1712.40	17.23	0.0101	2.5
			50	1712.40	13.97	0.0082	2.5
		VL	20	1712.40	15.43	0.0090	2.5
		VH	20	1712.40	17.13	0.0100	2.5
VERDICT				PASS			

 IC
 C
 PR
 测

Operation Mode	Channel Number	Test Condition		Channel Frequency (MHz)	Freq.Dev. (Hz)	Deviation (ppm)	Limit (ppm)
		Voltage (V)	Temp (°C)				
WCDMA1900	9262	VN	-20	1852.40	14.43	0.0078	2.5
			-10	1852.40	18.73	0.0101	2.5
			0	1852.40	15.21	0.0082	2.5
			10	1852.40	17.26	0.0093	2.5
			20	1852.40	17.26	0.0093	2.5
			30	1852.40	16.10	0.0087	2.5
			40	1852.40	17.01	0.0092	2.5
			50	1852.40	14.02	0.0076	2.5
		VL	20	1852.40	15.38	0.0083	2.5
		VH	20	1852.40	17.07	0.0092	2.5
VERDICT				PASS			

TE
 T
 OV
 檢

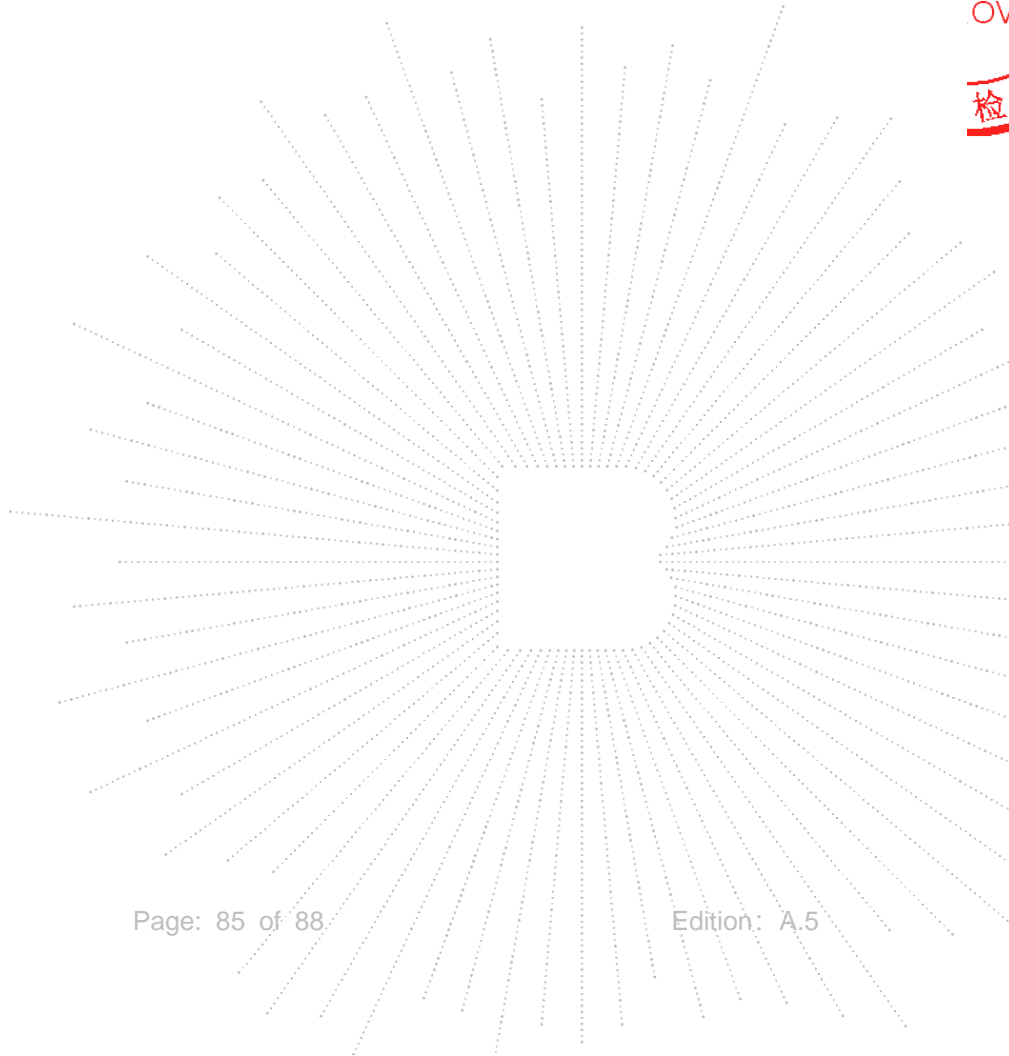

13. EUT Test Setup Photographs

Radiated Measurement Photos

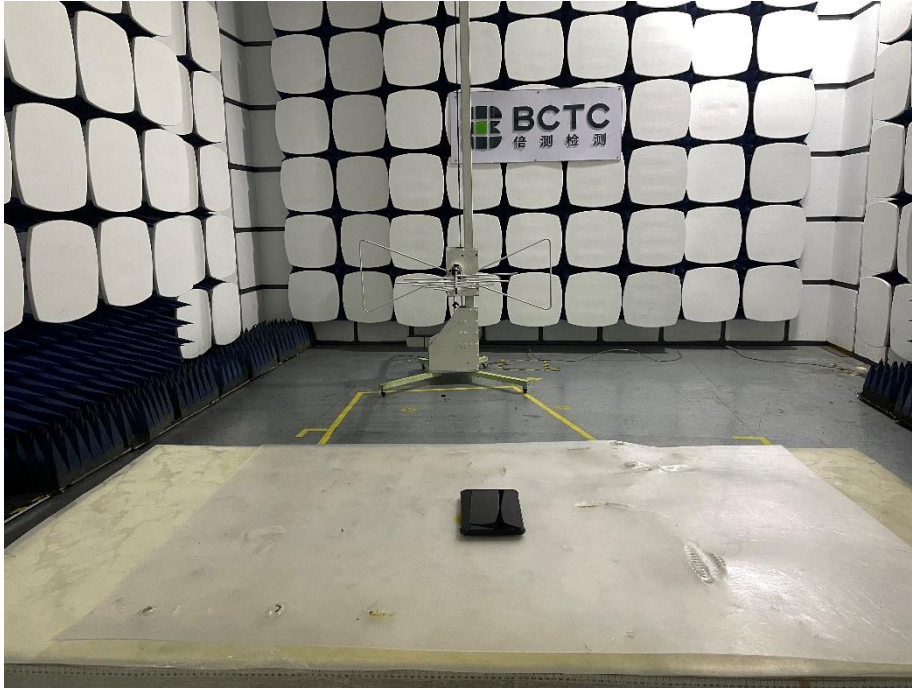

STATEMENT

1. The equipment lists are traceable to the national reference standards.
2. The test report can not be partially copied unless prior written approval is issued from our lab.
3. The test report is invalid without the "special seal for inspection and testing".
4. The test report is invalid without the signature of the approver.
5. The test process and test result is only related to the Unit Under Test.
6. Sample information is provided by the client and the laboratory is not responsible for its authenticity.
7. The test report without CMA mark is only used for scientific research, teaching, enterprise product development and internal quality control purposes.
8. The quality system of our laboratory is in accordance with ISO/IEC17025.
9. If there is any objection to this test report, the client should inform issuing laboratory within 15 days from the date of receiving test report.

Address:

1-2/F., Building B, Pengzhou Industrial Park, No.158, Fuyuan 1st Road, Zhancheng, Fuhai Subdistrict, Bao'an District, Shenzhen, Guangdong, China

TEL: 400-788-9558

P.C.: 518103

FAX: 0755-33229357

Website: <http://www.chnbctc.com>

E-Mail: bctc@bctc-lab.com.cn

***** END *****

2017