

Dates of Tests: September 10 ~ September 28, 2017
Test Report S/N: LR500111710E
Test Site : LTA CO., LTD.

CERTIFICATION OF COMPLIANCE

FCC ID.

2ANM8IDM22

APPLICANT

INDI TAG Co.,Ltd.

Equipment Class	:	Digital Transmission System (DTS)
Manufacturing Description	:	Zigbee Tag
Manufacturer	:	INDI TAG Co.,Ltd.
Model name	:	IDM22
Test Device Serial No.:	:	Identical prototype
Rule Part(s)	:	FCC Part 15.247 Subpart C ; ANSI C-63.4-2014
Frequency Range	:	2405 MHz ~ 2480 MHz
Max. Output Power	:	Max 8.28 dBm – Conducted
Data of issue	:	September 30, 2017

This test report is issued under the authority of:



Yong-Cheol, Wang / Manager

The test was supervised by:



Eun-hwan, Jung / Test Engineer

This test result only responds to the tested sample. It is not allowed to copy this report even partly without the allowance of the test laboratory. The report must not be used by the client to claim product certification, approval, or endorsement by NVLAP, NIST, or any agency of the Federal Government.



NVLAP LAB Code.: 200723-0

TABLE OF CONTENTS

1. GENERAL INFORMATION	-----	3
2. INFORMATION ABOUT TEST ITEM	-----	4
3. TEST REPORT	-----	6
3.1 SUMMARY OF TESTS	-----	6
3.2 TECHNICAL CHARACTERISTICS TEST	-----	7
3.2.1 6 dB BANDWIDTH	-----	7
3.2.2 PEAK OUTPUT POWER	-----	10
3.2.3 POWER SPECTRAL DENSITY	-----	13
3.2.4 BAND EDGE	-----	16
3.2.5 CONDUCTED SPURIOUS EMISSIONS	-----	19
3.2.6 RADIATED SPURIOUS EMISSIONS	-----	22
APPENDIX		
APPENDIX TEST EQUIPMENT USED FOR TESTS	-----	34

1. General information

1-1 Test Performed

Company name : LTA Co., Ltd.
 Address : 243, Jubug-ri, Yangji-Myeon, Youngin-Si, Kyunggi-Do, Korea. 17159
 Web site : <http://www.ltalab.com>
 E-mail : chahn@ltalab.com
 Telephone : +82-31-323-6008
 Facsimile : +82-31-323-6010

Quality control in the testing laboratory is implemented as per ISO/IEC 17025 which is the “General requirements for the competents of calibration and testing laboratory”.

1-2 Accredited agencies

LTA Co., Ltd. is approved to perform EMC testing by the following agencies:

Agency	Country	Accreditation No.	Validity	Reference
NVLAP	U.S.A	200723-0	2017-09-30	ECT accredited Lab.
RRA	KOREA	KR0049	-	EMC accredited Lab.
FCC	U.S.A	649054	2019-04-13	FCC CAB
VCCI	JAPAN	R2133(10 m), C2307	Updating	VCCI registration
VCCI	JAPAN	T-2009	2017-12-23	VCCI registration
VCCI	JAPAN	G-563	2018-12-13	VCCI registration
IC	CANADA	5799A-1	2019-11-07	IC filing
KOLAS	KOREA	NO.551	2021-08-20	KOLAS accredited Lab.

2. Information about test item

2-1 Client & Manufacturer

Company name : INDI TAG Co., Ltd.
Address : Nambusunhwan-ro 347-gil Seocho-gu, Seoul, Korea
Tel / Fax : TEL No : +82-2-3272-0068

2-3 Equipment Under Test (EUT)

Trade name : INDI TAG Co.,Ltd.
Model name : IDM22
Serial number : Identical prototype
Date of receipt : September 10, 2017
EUT condition : Pre-production, not damaged
Antenna type : IFA antenna - Max Gain 0 dBi
Frequency Range : 2405 MHz ~ 2480 MHz
RF output power : Max 8.20 dBm – Conducted
Number of channels : 16
Type of Modulation : Direct Sequence Spread Spectrum(DSSS)
Power Source : 6 Vdc
Firmware Version : V1.0.0

2-3 Tested frequency

Zigbee	LOW	MID	HIGH
Frequency (MHz)	2405	2440	2480

2-4 Ancillary Equipment

Equipment	Model No.	Serial No.	Manufacturer
Notebook	CR720	MS-1736	MSI

3. Test Report

3.1 Summary of tests

FCC Part Section(s)	Parameter	Limit	Test Condition	Status (note 1)
15.247(a)	6 dB Bandwidth	> 500 kHz	Conducted	C
15.247(b)	Transmitter Peak Output Power	< 1 Watt		C
15.247(d)	Transmitter Power Spectral Density	< 8 dBm @ 3 kHz		C
15.247(d)	Band Edge	> 20 dBc		C
15.209	Field Strength of Harmonics	Emission	Radiated	C
15.207	AC Conducted Emissions	Emissions	Conducted	N/A
15.203	Antenna requirement	-	-	C

Note 1: C=Complies NC=Not Complies NT=Not Tested NA=Not Applicable

Note 2: The data in this test report are traceable to the national or international standards.

→ Antenna Requirement

The INDI TAG Co.,Ltd. FCC ID: 2ANM8IDM42 unit complies with the requirement of §15.203.
The antenna type is IFA Antenna

The sample was tested according to the following specification:

- *FCC Parts 15.247; ANSI C-63.4-2014
- *FCC KDB Publication No. 558074 v03r05
- *FCC TCB Workshop 2012, April

3.2 Technical Characteristics Test

3.2.1 6 dB Bandwidth

Procedure:

The bandwidth at 6 dB below the highest in-band spectral density was measured with a spectrum analyzer connected to the antenna terminal, while EUT is operating in transmission mode at the appropriate frequencies.

After the trace being stable, Use the marker-to-peak function to set the marker to the peak of the emission. Use the marker-delta function to measure 6 dB down one side of the emission. Reset the marker-delta function, and move the marker to the other side of the emission, until it is (as close as possible to) even with the reference marker level. The marker-delta reading at this point is the 6 dB bandwidth of the emission.

The spectrum analyzer is set to:

Center frequency = the highest, middle and the lowest channels

RBW = 100 kHz

Span = 5 MHz

VBW = 100 kHz (VBW \geq RBW)

Sweep = auto

Trace = max hold

Detector function = peak

Measurement Data : **Complies**

Frequency (MHz)	Test Results	
	Measured Bandwidth (MHz)	Result
2405	1.6281	Complies
2440	1.6136	Complies
2480	1.6136	Complies

- See next pages for actual measured spectrum plots.

Minimum Standard:

6 dB Bandwidth > 500 kHz

Measurement Setup

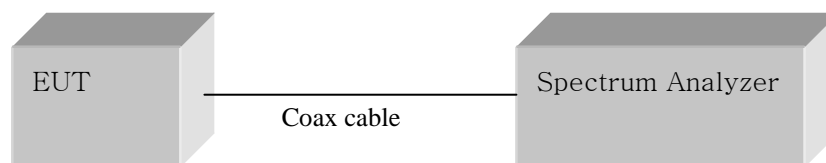
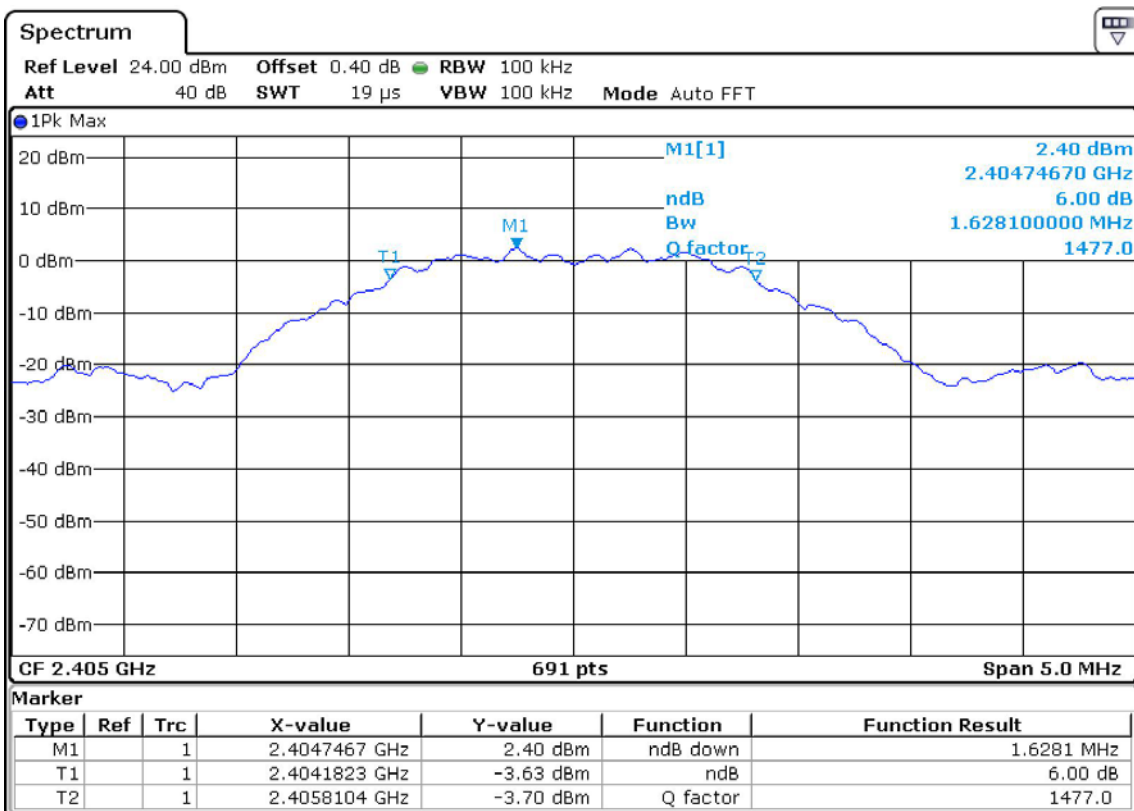
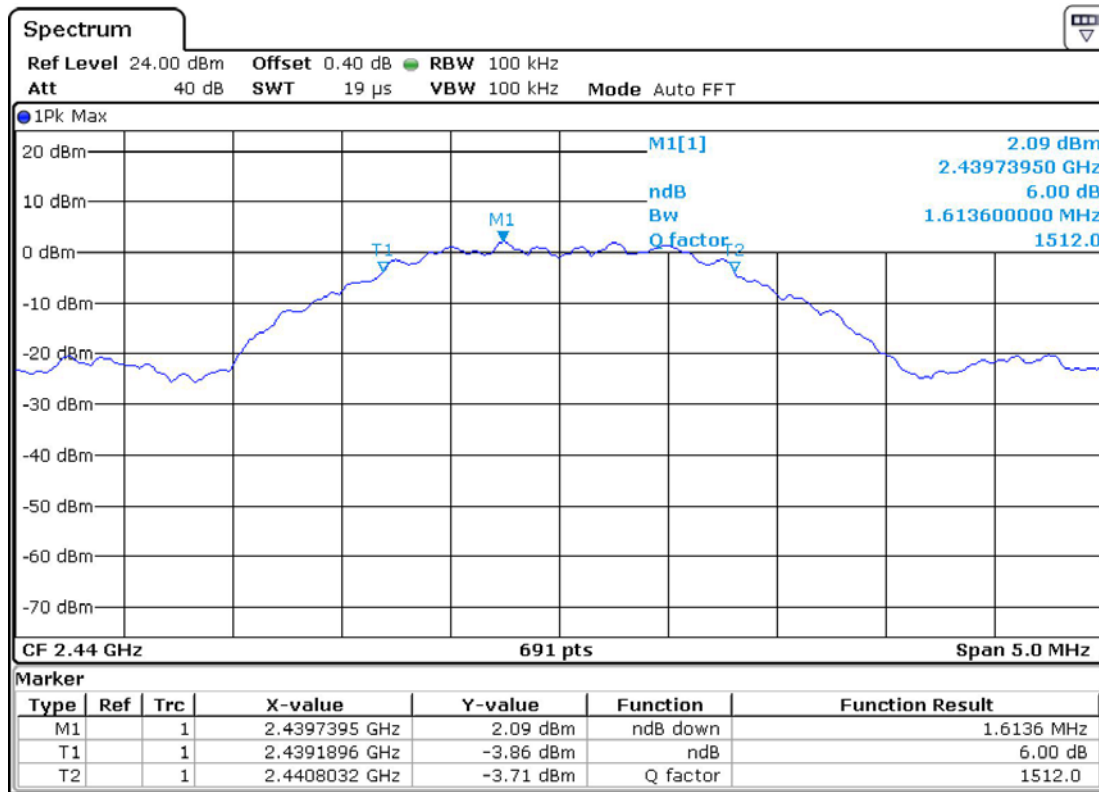

Figure 1: Measurement setup for the carrier frequency separation

Low Channel



Middle Channel



High Channel

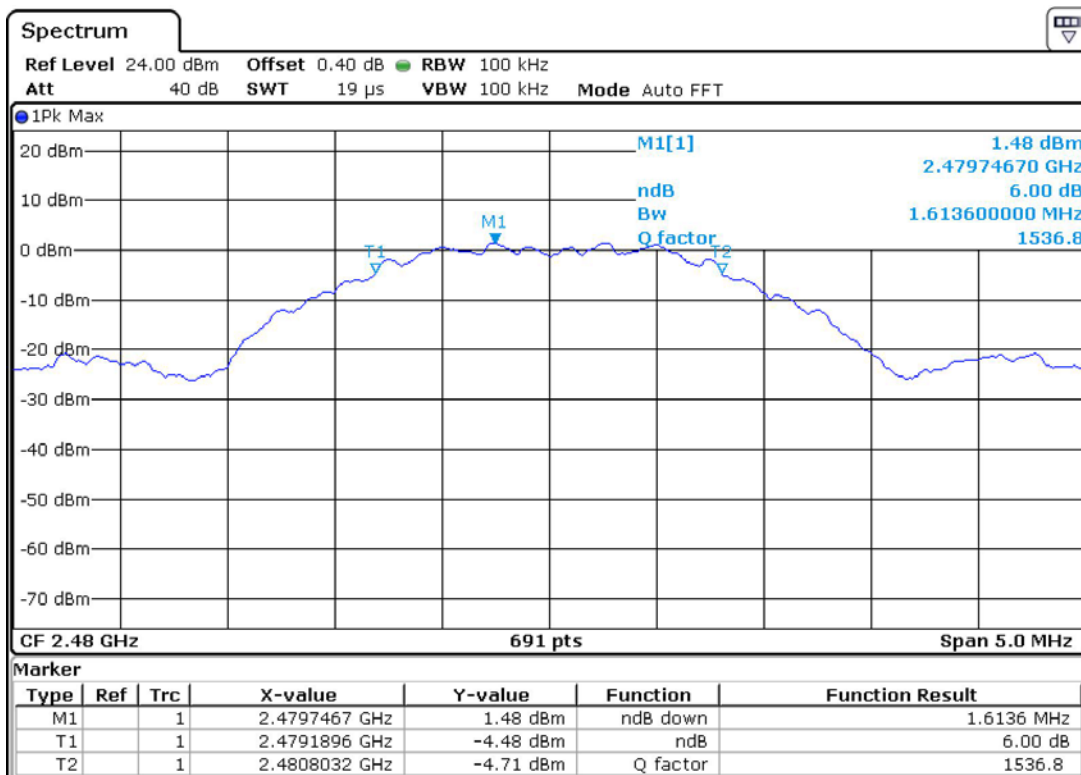

3.2.2 Peak Output Power Measurement

Procedure:

The maximum peak output power was measured with the spectrum analyzer connected to the antenna output of the EUT. The spectrum analyzer's internal channel power integration function is used to integrate the power over a bandwidth greater than or equal to the 99% bandwidth. The EUT was operating in transmit mode at the appropriate center frequency.

The spectrum analyzer is set to:

Center frequency = the highest, middle and the lowest channels

RBW = 1MHz

Span = auto

VBW = 1MHz (VBW \geq RBW)

Sweep = auto

Detector function = peak

Measurement Data (Port 1) : **Complies**

Frequency (MHz)	Test Results		
	dBm	W	Result
2405	8.28	0.0067	Complies
2440	7.79	0.0054	Complies
2480	7.37	0.0055	Complies

- See next pages for actual measured spectrum plots.

Minimum Standard:

Peak output power	< 1 W
-------------------	-------

Measurement Setup

Same as the Chapter 3.2.1 (Figure 1)

Low Channel

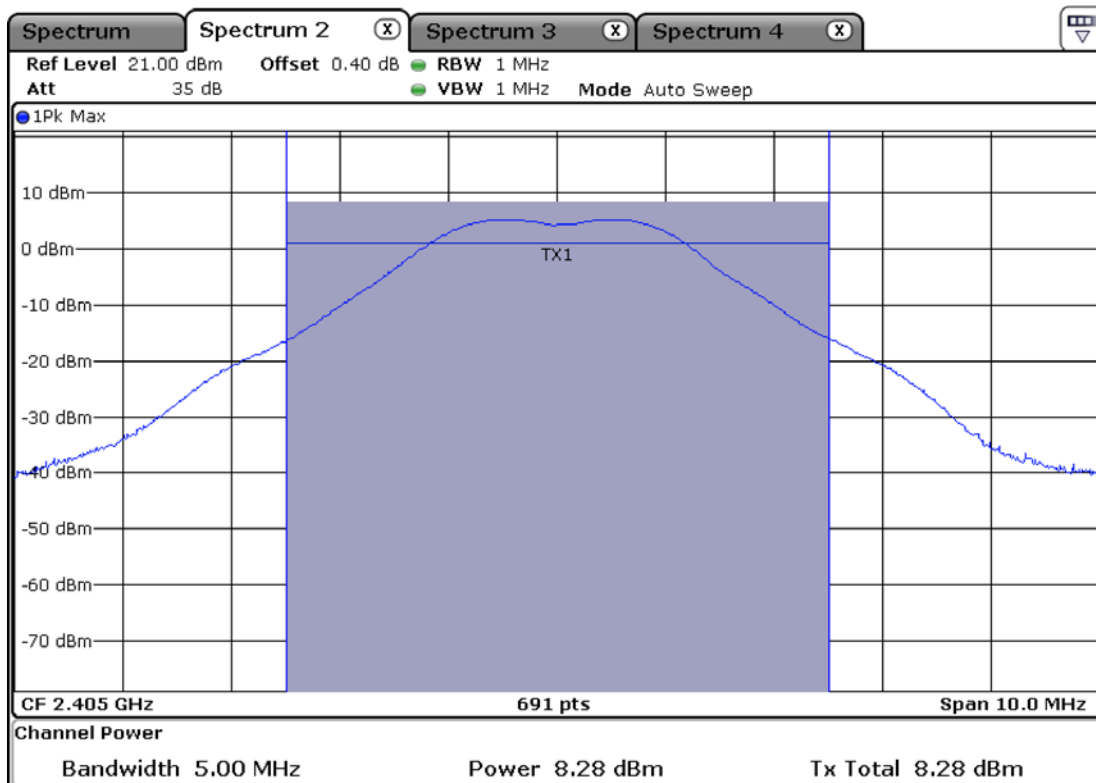

Middle Channel

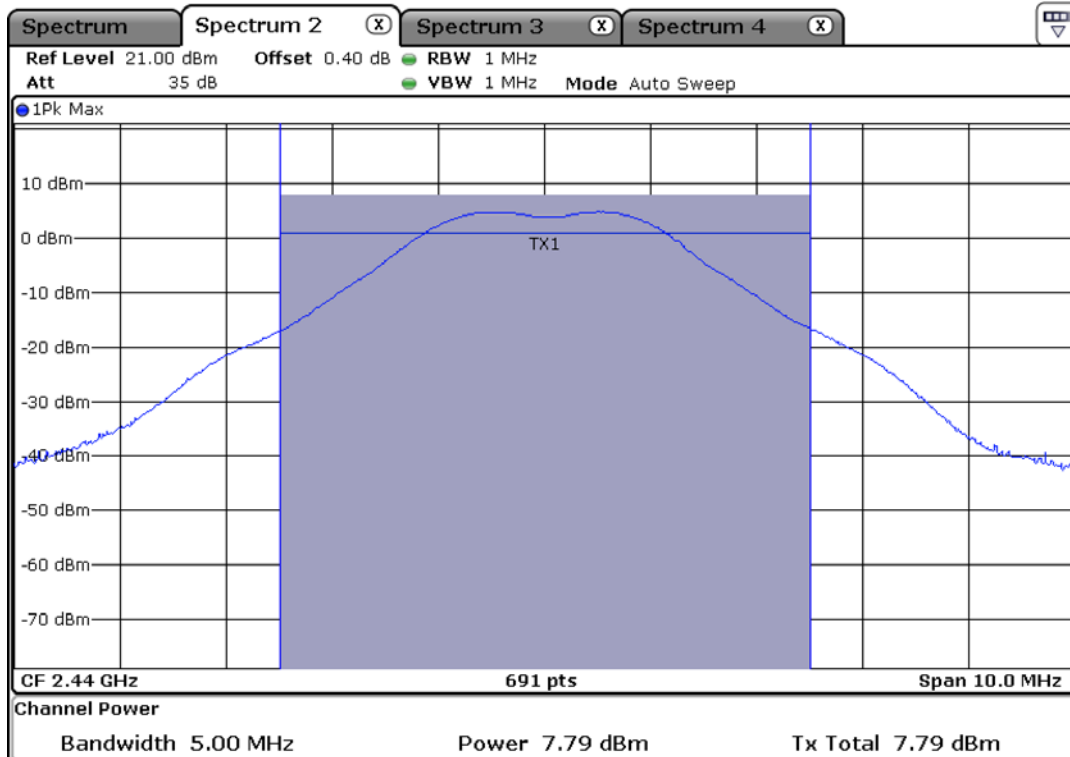

High Channel

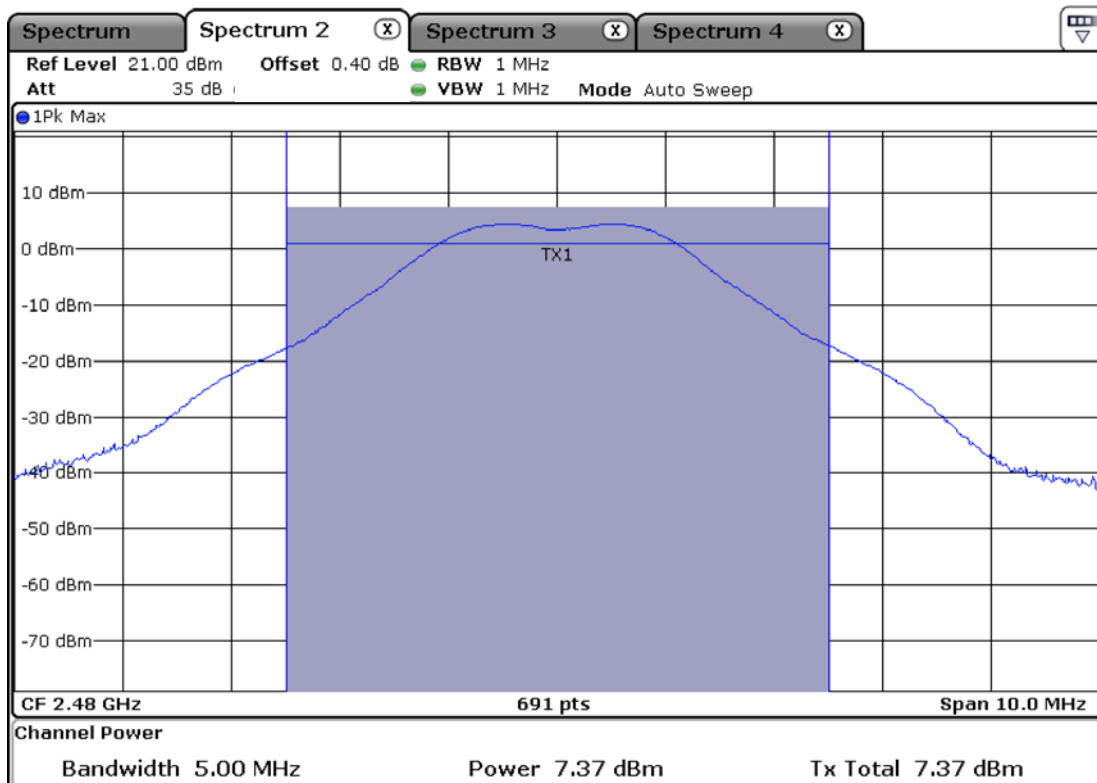

3.2.3 Power Spectral Density

Procedure:

The peak power density is measured with a spectrum analyzer connected to the antenna terminal while the EUT is operating in transmission mode at the appropriate frequencies.

The spectrum analyzer is set to:

RBW = 3 kHz

Span = 300 kHz

VBW = 3 kHz

Sweep = auto

Detector function = peak

Trace = max hold

Measurement Data (Port 1) : **Complies**

Frequency (MHz)	Test Results	
	dBm @ 3kHz	Result
2405	-9.30	Complies
2440	-10.22	Complies
2480	-7.87	Complies

- See next pages for actual measured spectrum plots.

Minimum Standard:

Power Spectral Density	< 8 dBm @ 3 kHz BW
------------------------	--------------------

Measurement Setup

Same as the Chapter 3.2.1 (Figure 1)

Power Density Measurement Low Channel

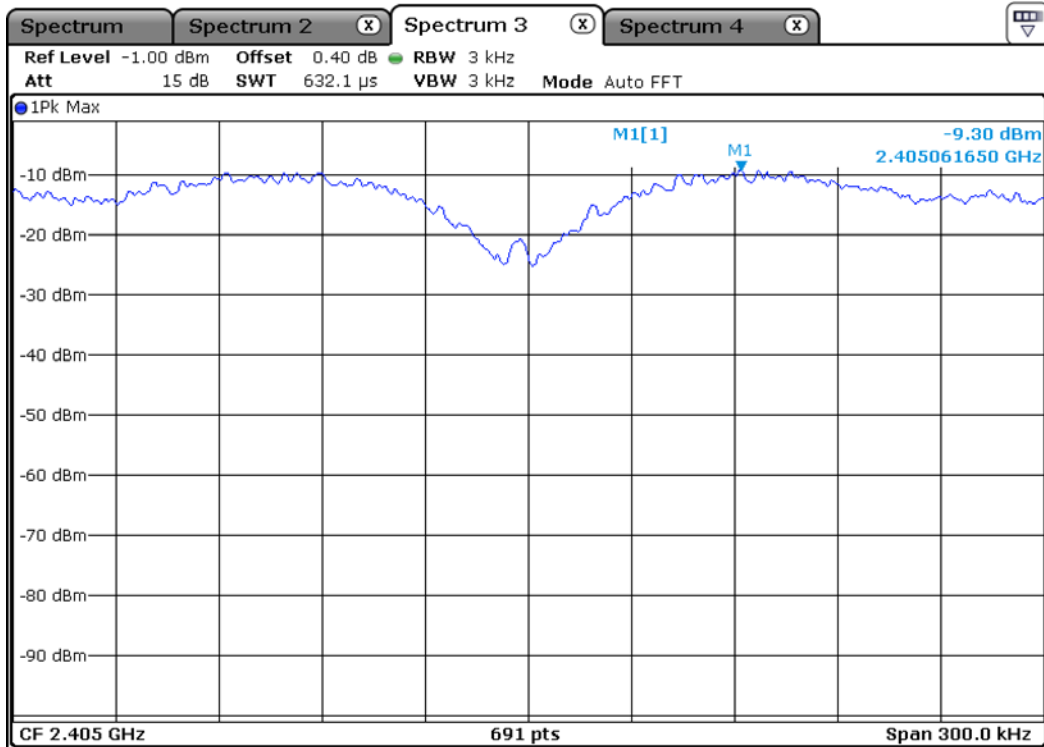

Middle Channel

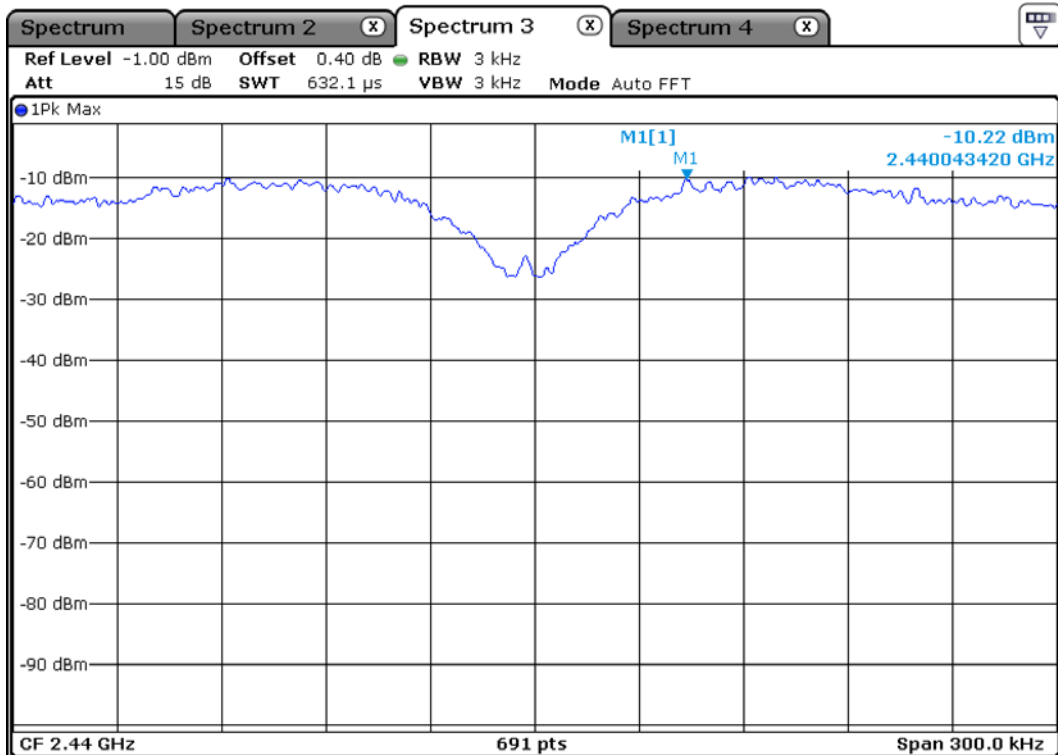

High Channel

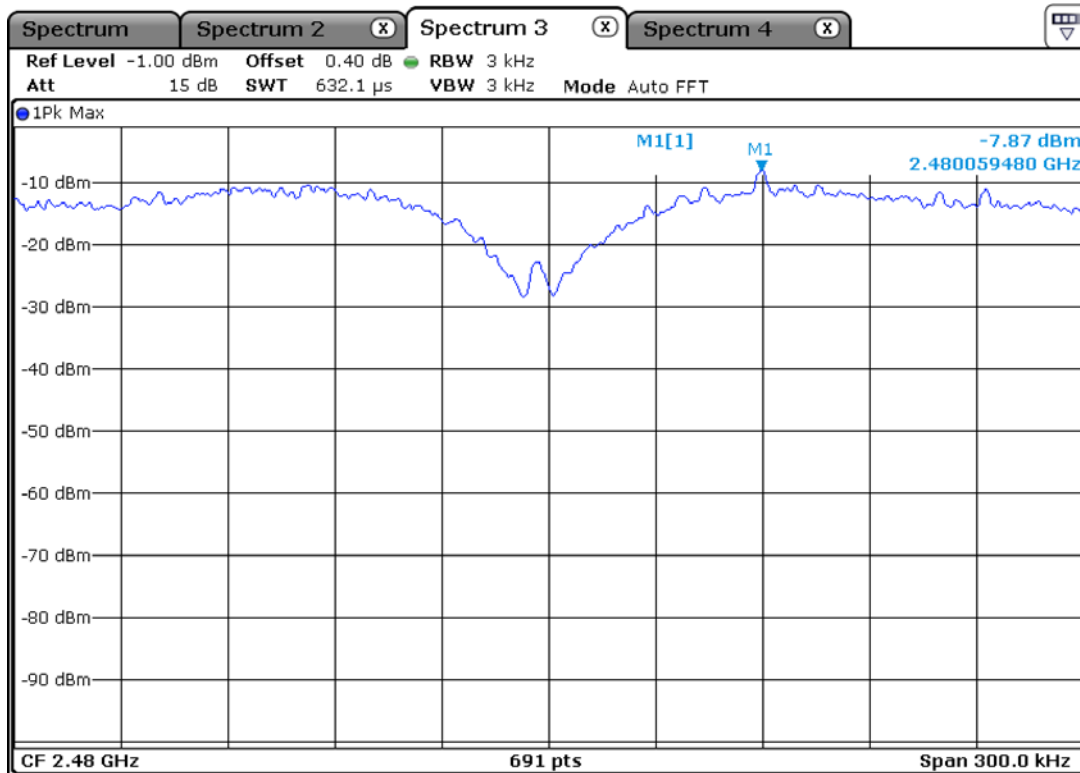

3.2.4 Band - edge

Procedure:

The bandwidth at 20 dB down from the highest inband spectral density is measured with a spectrum analyzer connected to the antenna terminal, while EUT is operating in transmission mode at the appropriate frequencies.

After the trace being stable, Use the marker-to-peak function to measure 20 dB down both sides of the intentional emission.

The spectrum analyzer is set to:

Center frequency = the highest, middle and the lowest channels

RBW = 100 kHz

VBW = 100 kHz

Span = 40 MHz

Detector function = peak

Trace = max hold

Sweep = auto

Radiated emissions which fall in the restricted bands, as defined in 15.205(a), must also comply with the radiated emission limits specified in 15.209(a)

The spectrum analyzer is set to:

Center frequency = the highest, the lowest channels

PEAK:

RBW = VBW = 1 MHz, Sweep=Auto

Average:

RBW = 1 MHz, VBW=10 Hz, Sweep=Auto

Measurement Distance:

3 m

Polarization:

Horizontal / Vertical

Measurement Data: Complies

- All conducted emission in any 100 kHz bandwidth outside of the spread spectrum band was at least 20 dB lower than the highest inband spectral density. Therefore the applying equipment meets the requirement.
- See next pages for actual measured spectrum plots.

Minimum Standard:	> 20 dBc
--------------------------	----------

Band edge Lower edge

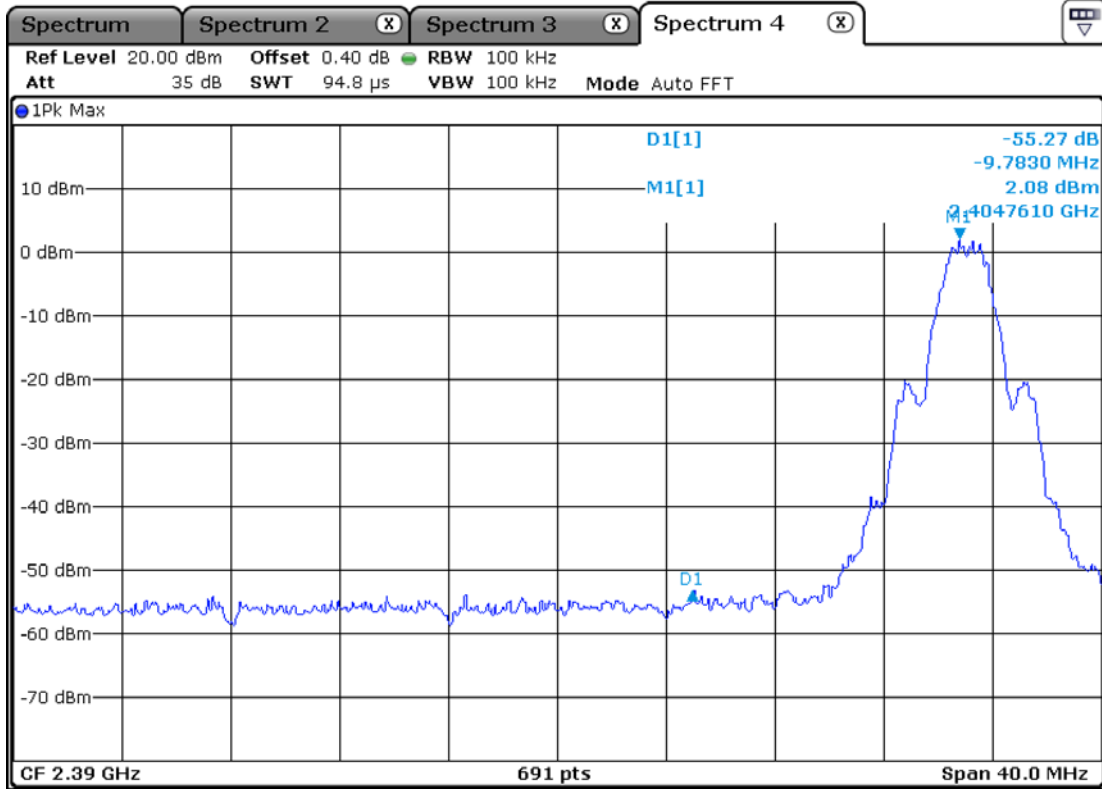

Upper edge

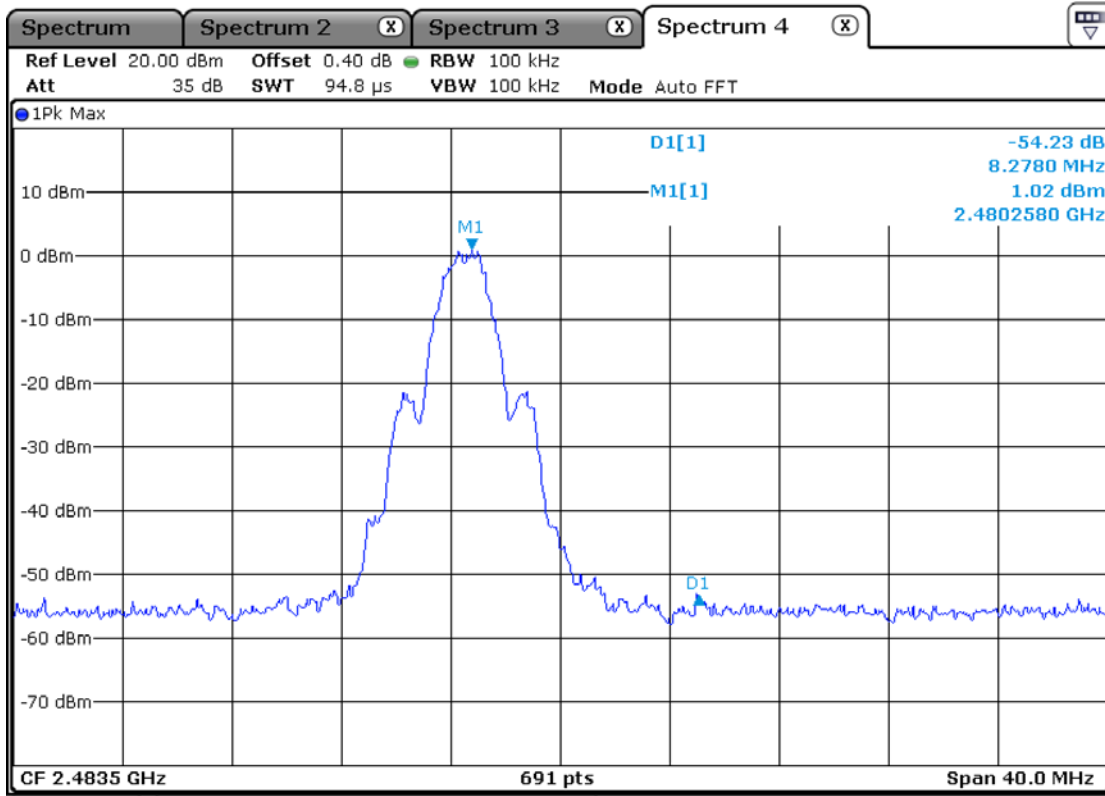

Radiated Band-edges in the restricted band 2310-2390 MHz measurement

Frequency [MHz]	Reading [dBuV/m]		Pol.	Correction Factor		Limits [dBuV/m]		Result [dBuV/m]		Margin [dB]	
	AV / Peak			Antenna	Amp. Gain + Cable Loss	AV / Peak		AV / Peak		AV / Peak	
2483.5	30.2	47.7	H	25.4	30.1	54.0	74.0	25.5	43.0	28.5	31.0

Radiated Band-edges in the restricted band 2483.5-2500 MHz measurement

Frequency [MHz]	Reading [dBuV/m]		Pol.	Correction Factor		Limits [dBuV/m]		Result [dBuV/m]		Margin [dB]	
	AV / Peak			Antenna	Amp. Gain + Cable Loss	AV / Peak		AV / Peak		AV / Peak	
2486.2	48.2	57.1	H	25.4	30.1	54.0	74.0	43.5	52.4	10.5	21.6

Note : This EUT was tested in 3 orthogonal positions and the worst-case data was presented

3.2.5 Conducted Spurious Emissions

Procedure:

The test follows KDB558074. The conducted spurious emissions were measured with a spectrum analyzer connected to the antenna terminal, while EUT had its hopping function disabled at the highest, middle and the lowest available channels..

After the trace being stable, set the marker on the peak of any spurious emission recorded.

The spectrum analyzer is set to:

Span = wide enough to capture the peak level of the in-band emission and all spurious emissions

RBW = 100 kHz

Sweep = auto

VBW = 100 kHz

Detector function = peak

Trace = max hold

Measurement Data: **Complies**

- All conducted emission in any 100 kHz bandwidth outside of the spread spectrum band was at least 20 dB lower than the highest inband spectral density. Therefore the applying equipment meets the requirement.
- See next pages for actual measured spectrum plots.

Minimum Standard:	> 20 dBc
--------------------------	----------

Measurement Setup

Same as the Chapter 3.2.1 (Figure 1)

Unwanted Emission – Low Channel
Frequency Range = 30 MHz ~ 26.5 GHz

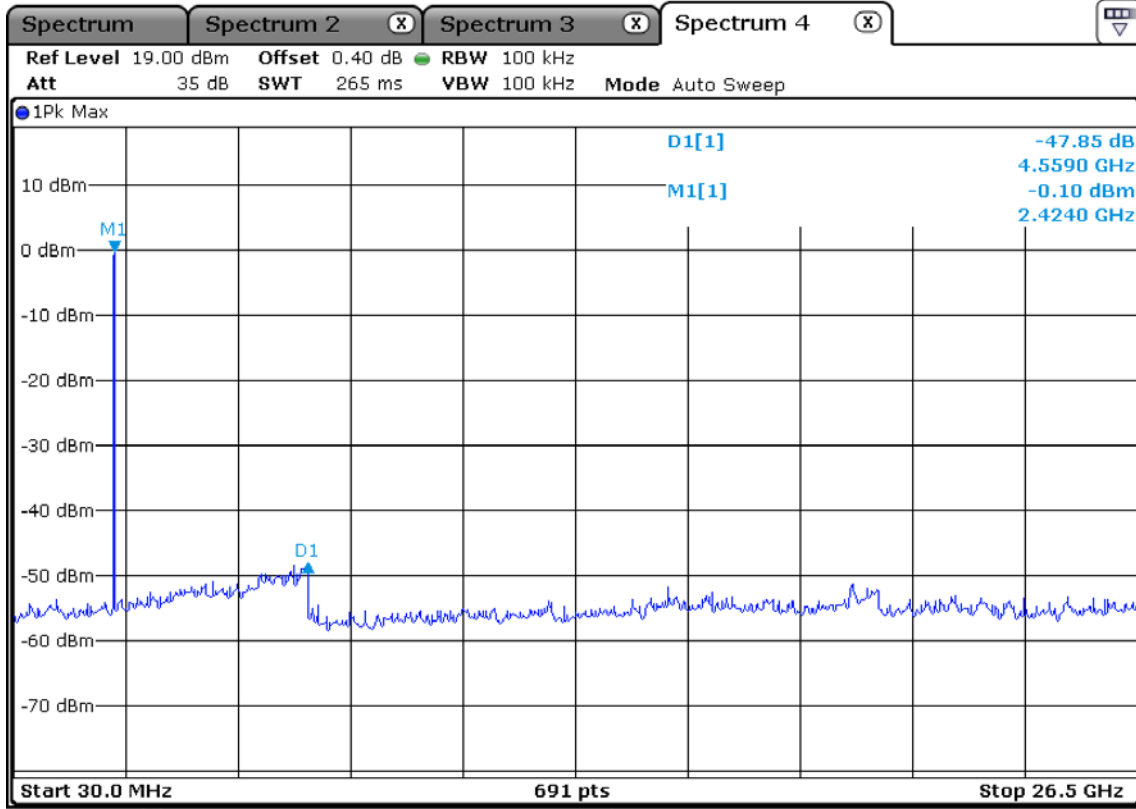

Middle Channel

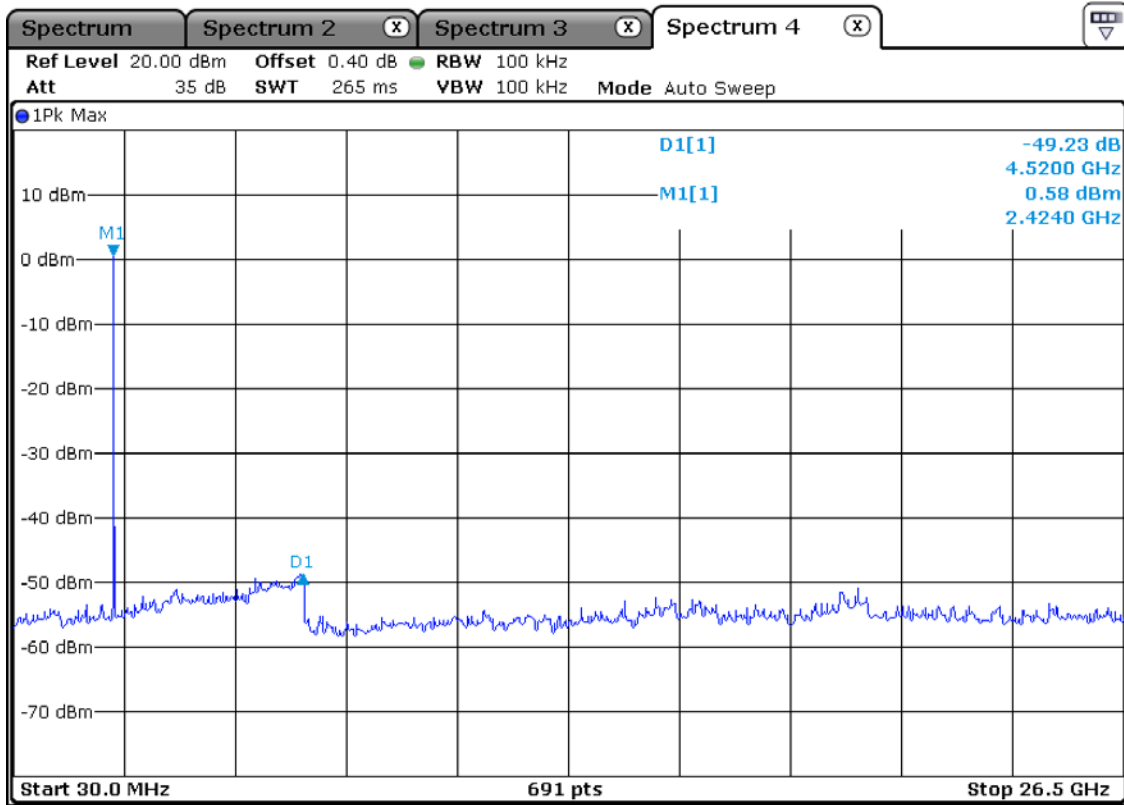

High Channel

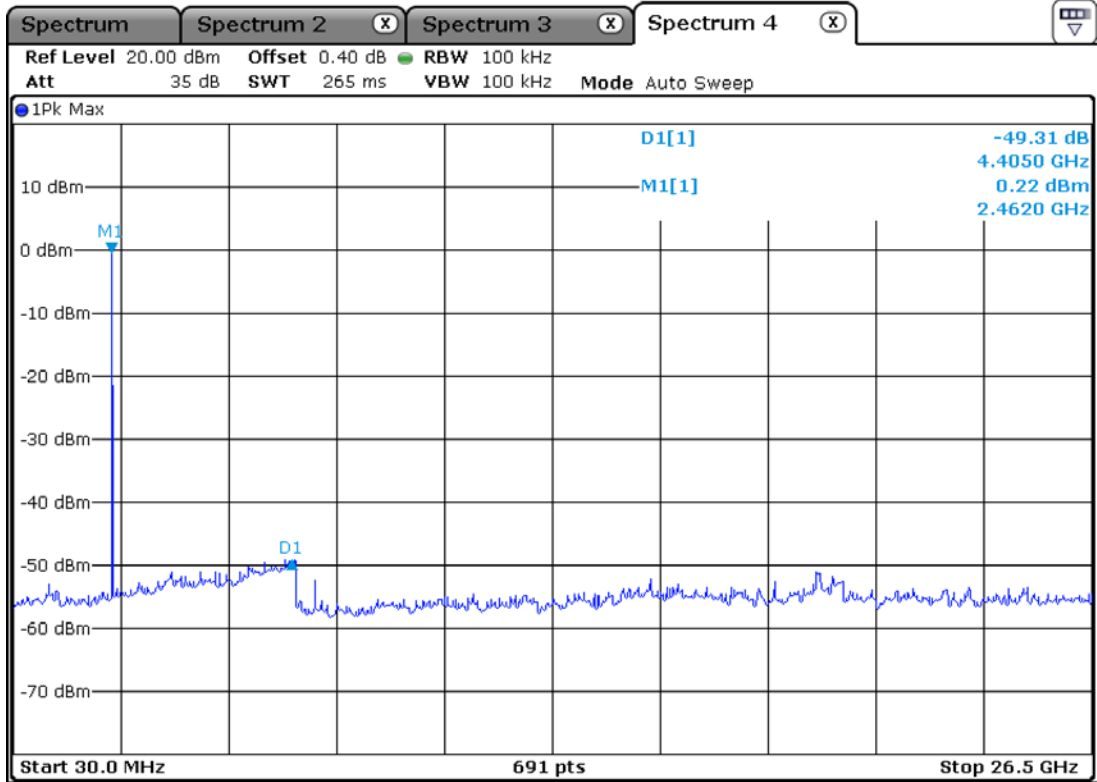

3.2.6 Radiated Spurious Emissions

Procedure:

The EUT was placed on a 0.8m high wooden table inside a shielded enclosure. An antenna was placed near the EUT and measurements of frequencies and amplitudes of field strengths were recorded for reference during final measurements. For final radiated testing, measurements were performed in OATS. Measurements were performed with the EUT oriented in 3 orthogonal axis and rotated 360 degrees to determine worst-case orientation for maximum emissions.

The spectrum analyzer is set to:

Center frequency = the worst channel

Frequency Range = 9 kHz ~ 10th harmonic.

RBW = 100 kHz (30 MHz ~ 1 GHz)

= 1 MHz (1 GHz ~ 10th harmonic)

Span = 100 MHz

Trace = max hold

VBW \geq RBW

Detector function = peak

Sweep = auto

below 30 MHz

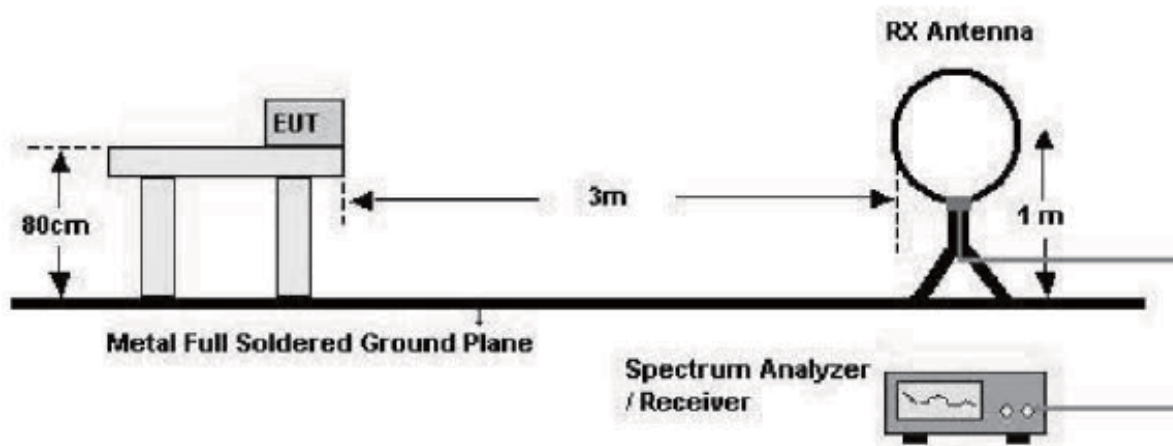

below 1 GHz (30 MHz to 1 GHz)

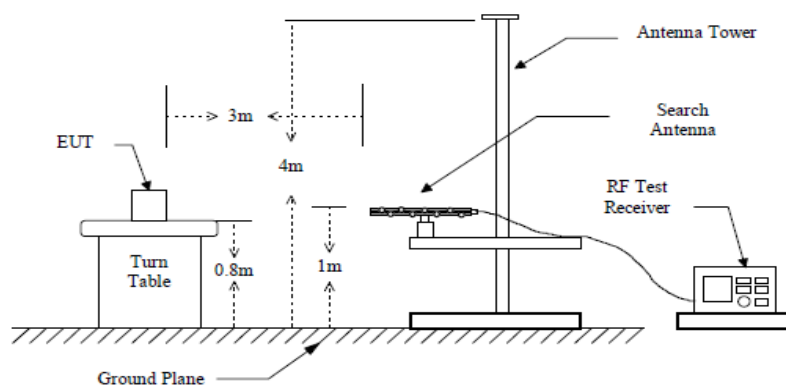

above 1 GHz

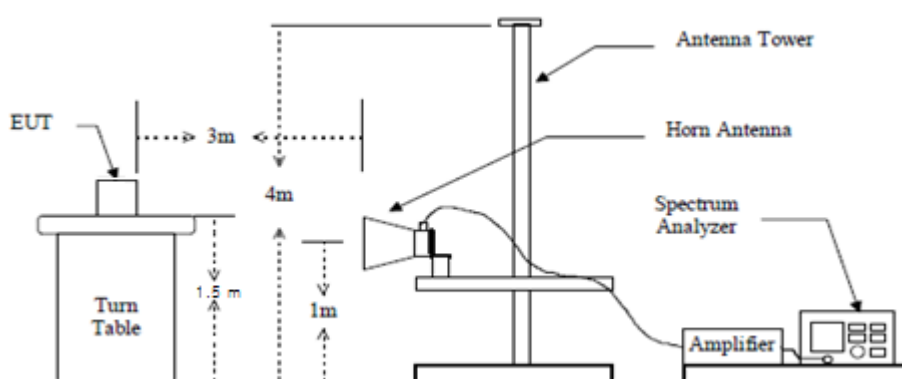

Measurement Data: Complies

- See next pages for actual measured data.
- No other emissions were detected at a level greater than 20 dB below limit include from 9 kHz to 30 MHz.

Minimum Standard: FCC Part 15.209(a)

Frequency (MHz)	Limit (uV/m) @ 3 m
0.009 ~ 0.490	2400/F(kHz) (@ 300 m)
0.490 ~ 1.705	24000/F(kHz) (@ 30 m)
1.705 ~ 30	30(@ 30 m)
30 ~ 88	100 **
88 ~ 216	150 **
216 ~ 960	200 **
Above 960	500

** Except as provided in 15.209(g), fundamental emissions from intentional radiators operating under this Section shall not be located in the frequency bands 54-72 MHz, 76-88 MHz, 174-216 MHz or 470-806 MHz. However, operation within these frequency bands is permitted under other sections of this Part, e.g. 15.231 and 15.241.

Measurement Data : (Above 1 GHz)

Frequency [MHz]	Reading [dBuV/m]		Pol.	Correction Factor		Limits [dBuV/m]		Result [dBuV/m]		Margin [dB]	
	AV / Peak			Antenna	Amp.Gain+Cable	AV/Peak		AV/Peak		AV / Peak	
2883.6	30.5	45.3	H	28.15	21.61	60.0	80.0	37.04	51.84	22.96	28.16
2162.8	31.2	45.0	H	28.15	25.92	60.0	80.0	34.03	49.93	25.97	30.07
2028.6	34.2	50.4	H	28.15	26.41	60.0	80.0	35.89	52.09	24.11	27.91

- No other emissions were detected at a level greater than 20 dB below limit.

Measurement Data : (Below 1 GHz)

Frequency [MHz]	Reading [dBuV/m]		Pol.	Correction Factor		Limits [dBuV/m]		Result [dBuV/m]		Margin [dB]	
	AV / Peak			Antenna	Amp.Gain+Cable	AV/Peak		AV/Peak		AV / Peak	
38.73	50.57	59.46	V	11.32	-25.67	54.0	74.0	45.9	54.8	8.1	19.2
33.88	50.71	57.94	V	11.32	-26.16	54.0	74.0	46.0	53.2	8.0	20.8
38.73	50.85	60.13	V	11.32	-26.16	39.0	46.2	46.2	55.4	7.9	18.6

- No other emissions were detected at a level greater than 20 dB below limit.

Measurement Data: (9 kHz – 30 MHz)

Frequency [MHz]	Reading [dBuV/m]		Pol.	Correction Factor		Limits [dBuV/m]	Result [dBuV/m]	Margin [dB]
	Peak			Antenna + Cable-Amp.Gain	Peak	Peak	Peak	
*No emissions were detected at a level greater than 20 dB below limit.								

*No emissions were detected at a level greater than 20 dB below limit.

Radiated Emissions (Below 1 GHz) – 2.4 GHz Zigbee(Low) mode, Vertical



4, Songjuro 236Beon-gil, yanggi-myeon,
Yongin-si, Gyeonggi-do, Korea
Tel : +82-31-3236008,9
Fax : +82-31-3236010
www.ltalab.com

EUT/Model No.: IDM22 Temp/Humi: 24 / 58

Test Mode : Wireless mode (LOW) Tested by: LEE H W

Data: 1609 File: C:\Program Files (x86)\e3\1709-1.EM6 (1680)

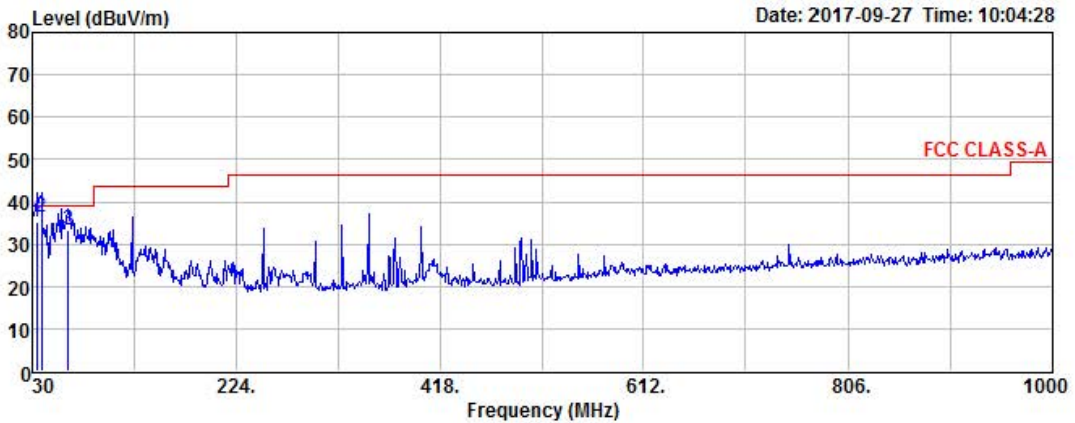

Freq	Reading	C.F	Result	Limit	Margin	Height	Angle	Polarity
MHz	dBuV	dB	QP dBuV/m	dBuV/m	dB	cm	deg	
33.88	50.09	-14.84	35.25	39.00	3.75	109	63	VERTICAL
38.73	50.57	-14.35	36.22	39.00	2.78	344	122	VERTICAL
63.95	48.32	-15.04	33.28	39.00	5.72	263	22	VERTICAL

Remarks: C.F (Correction Factor) = Antenna factor + Cable loss - Preamp gain

Radiated Emissions (Below 1 GHz) – 2.4GHz Zigbee(Middle) mode, Vertical



4, Songjiuro 236Beon-gil, yanggi-myeon,
Yongin-si, Gyeonggi-do, Korea
Tel : +82-31-3236008,9
Fax : +82-31-3236010
www.ltalab.com

EUT/Model No.: IDM22 Temp/Humi: 24 / 58

Test Mode : Wireless mode (MID) Tested by: LEE H W

Data: 1611 File: C:\Program Files (x86)\e3\1709-1.EM6 (1680) Date: 2017-09-27 Time: 10:07:16

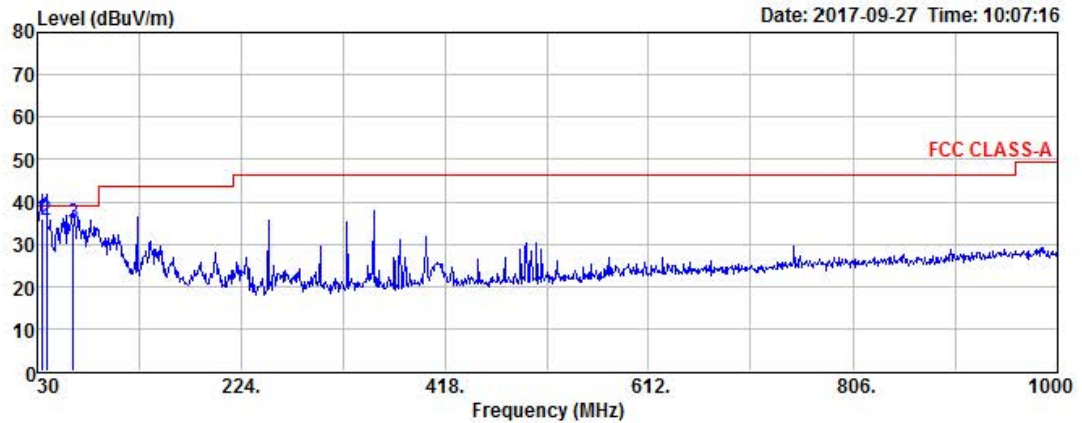

Freq MHz	Reading dBuV	C.F dB	Result QP dBuV/m	Limit dBuV/m	Margin dB	Height cm	Angle deg	Polarity
33.88	50.71	-14.84	35.87	39.00	3.13	214	299	VERTICAL
38.73	50.09	-14.35	35.74	39.00	3.26	322	175	VERTICAL
63.95	49.80	-15.04	34.76	39.00	4.24	127	88	VERTICAL

Remarks: C.F (Correction Factor) = Antenna factor + Cable loss - Preamp gain

Radiated Emissions (Below 1 GHz) – 2.4GHz Zigbee(High) mode, Vertical



4, Songjuro 236Beon-gil, yanggi-myeon,
Yongin-si, Gyeonggi-do, Korea
Tel : +82-31-3236008,9
Fax : +82-31-3236010
www.ltalab.com

EUT/Model No.: IDM22 Temp/Humi: 24 / 58
Test Mode : Wireless mode (HIGH) Tested by: LEE H W

Data: 1613 File: C:\Program Files (x86)\e3\1709-1.EM6 (1680)

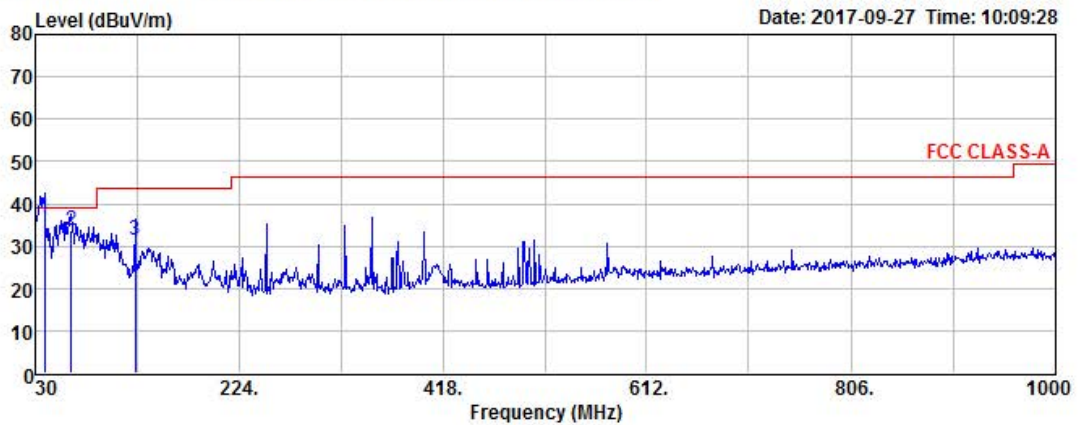

Freq MHz	Reading dBuV	C.F dB	Result QP dBuV/m	Limit dBuV/m	Margin dB	Height cm	Angle deg	Polarity
38.73	50.85	-14.35	36.50	39.00	2.50	217	55	VERTICAL
63.95	48.70	-15.04	33.66	39.00	5.34	255	204	VERTICAL
125.06	44.51	-13.31	31.20	43.50	12.30	281	330	VERTICAL

Remarks: C.F (Correction Factor) = Antenna factor + Cable loss - Preamp gain

Radiated Emissions (Below 1 GHz) – 2.4 GHz Zigbee(Low) mode, Horizontal



4, Songjuro 236Beon-gil, yanggi-myeon,
Yongin-si, Gyeonggi-do, Korea
Tel : +82-31-3236008,9
Fax : +82-31-3236010
www.ltalab.com

EUT/Model No.: IDM22 Temp/Humi: 24 / 58
Test Mode : Wireless mode (LOW) Tested by: LEE H W

Data: 1608 File: C:\Program Files (x86)\e3\1709-1.EM6 (1680)

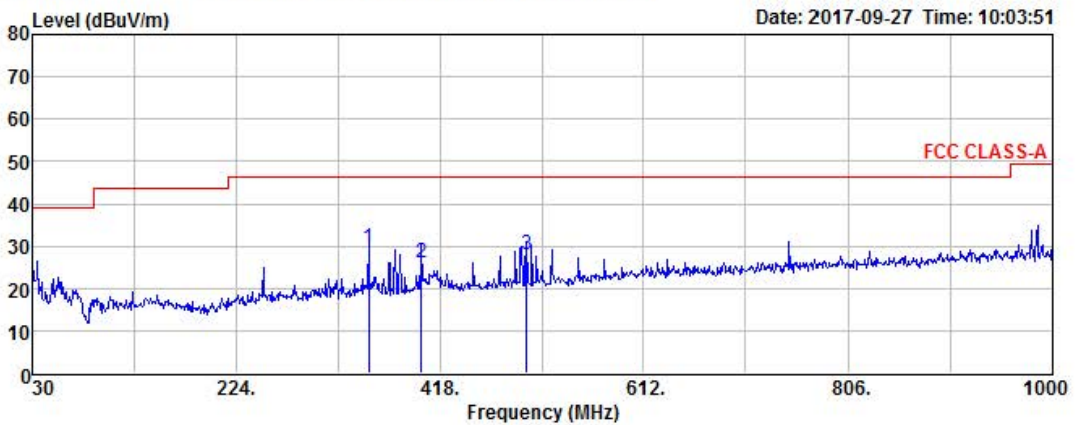

Freq	Reading	C.F	Result	Limit	Margin	Height	Angle	Polarity
MHz	dBuV	dB	QP dBuV/m	dBuV/m	dB	cm	deg	
350.10	38.94	-9.59	29.35	46.40	17.05	203	163	HORIZONTAL
400.54	34.70	-8.49	26.21	46.40	20.19	180	116	HORIZONTAL
500.45	34.67	-6.64	28.03	46.40	18.37	274	88	HORIZONTAL

Remarks: C.F (Correction Factor) = Antenna factor + Cable loss - Preamp gain

Radiated Emissions (Below 1 GHz) – 2.4GHz Zigbee(Middle) mode, Horizontal



4, Songjiuro 236Beon-gil, yanggi-myeon,
Yongin-si, Gyeonggi-do, Korea
Tel : +82-31-3236008,9
Fax : +82-31-3236010
www.ltalab.com

EUT/Model No.: IDM22 Temp/Humi: 24 / 58
Test Mode : Wireless mode (MID) Tested by: LEE H W

Data: 1610 File: C:\Program Files (x86)\e3\1709-1.EM6 (1680)

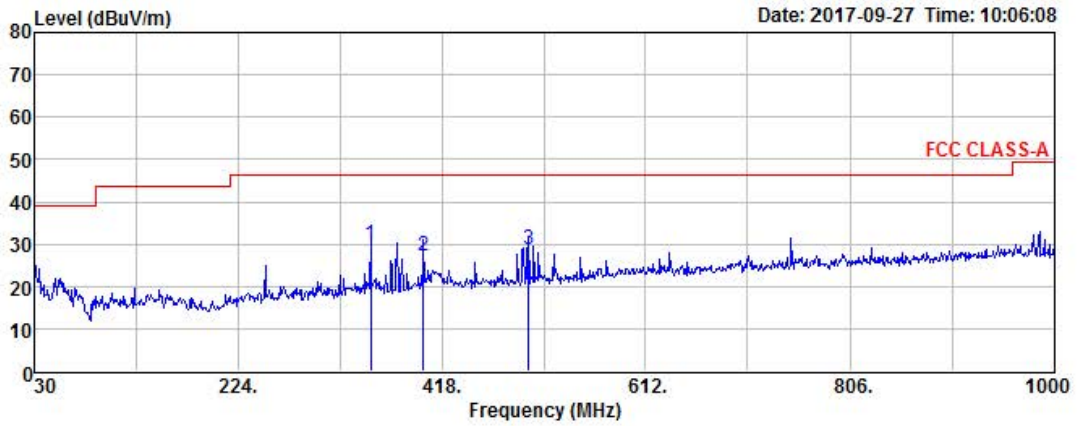

Freq MHz	Reading dBuV	C.F dB	Result QP dBuV/m	Limit dBuV/m	Margin dB	Height cm	Angle deg	Polarity
350.10	39.52	-9.59	29.93	46.40	16.47	112	207	HORIZONTAL
400.54	35.48	-8.49	26.99	46.40	19.41	267	153	HORIZONTAL
500.45	35.42	-6.64	28.78	46.40	17.62	143	308	HORIZONTAL

Remarks: C.F (Correction Factor) = Antenna factor + Cable loss - Preamp gain

Radiated Emissions (Below 1 GHz) – 2.4GHz Zigbee(High) mode, Horizontal



4, Songjuro 236Beon-gil, yanggi-myeon,
Yongin-si, Gyeonggi-do, Korea
Tel : +82-31-3236008,9
Fax : +82-31-3236010
www.ltalab.com

EUT/Model No.: IDM22 Temp/Humi: 24 / 58
Test Mode : Wireless mode (HIGH) Tested by: LEE H W

Data: 1612 File: C:\Program Files (x86)\e3\1709-1.EM6 (1680)

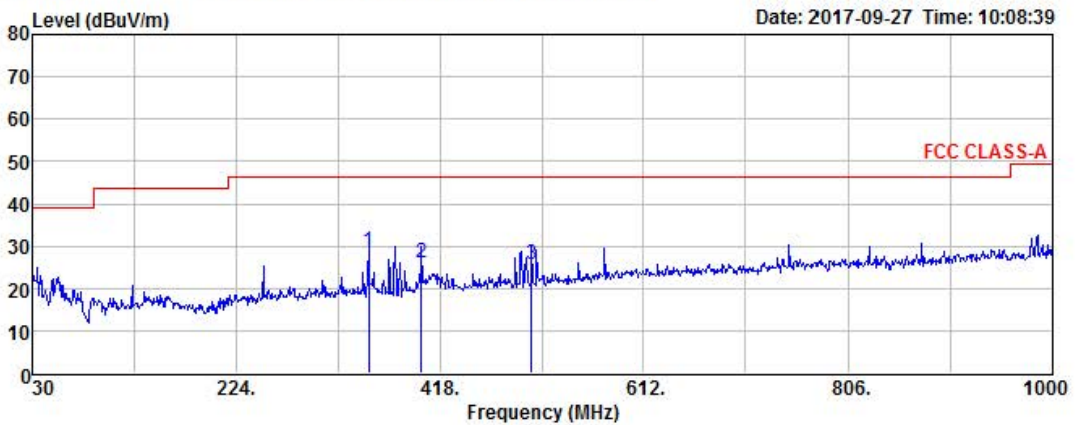

Freq MHz	Reading dBuV	C.F dB	Result QP dBuV/m	Limit dBuV/m	Margin dB	Height cm	Angle deg	Polarity
350.10	38.38	-9.59	28.79	46.40	17.61	318	205	HORIZONTAL
400.54	34.54	-8.49	26.05	46.40	20.35	288	56	HORIZONTAL
505.30	32.35	-6.54	25.81	46.40	20.59	211	195	HORIZONTAL

Remarks: C.F (Correction Factor) = Antenna factor + Cable loss - Preamp gain

Radiated Emissions (Above 1 GHz) – 2.4 GHz Zigbee(Low) mode



EMI Chamber of LTA CO.,LTD.
 4, Songjuro236Beon-gil, Yangji-myeon,
 Yongin-si, Gyeonggi-do, Korea Autho.by NVLAP
 Tel :+82-31-3236008,9 www.ltalab.com
 Fax:+82-31-3236010

EUT/Model No.: IDM22 Test Mode: Wireless mode (LOW)
 Tested by : LEE H W Temp/Humi: 24 / 58

Data: 10 File: D:\LTA_e3le3_backup\1GHz 이상\2017\CH1_ABOVE 1GHz_1709-1.EMI (17) Date: 2017-09-27 Time: 10:25:58
 Level (dBuV/m)

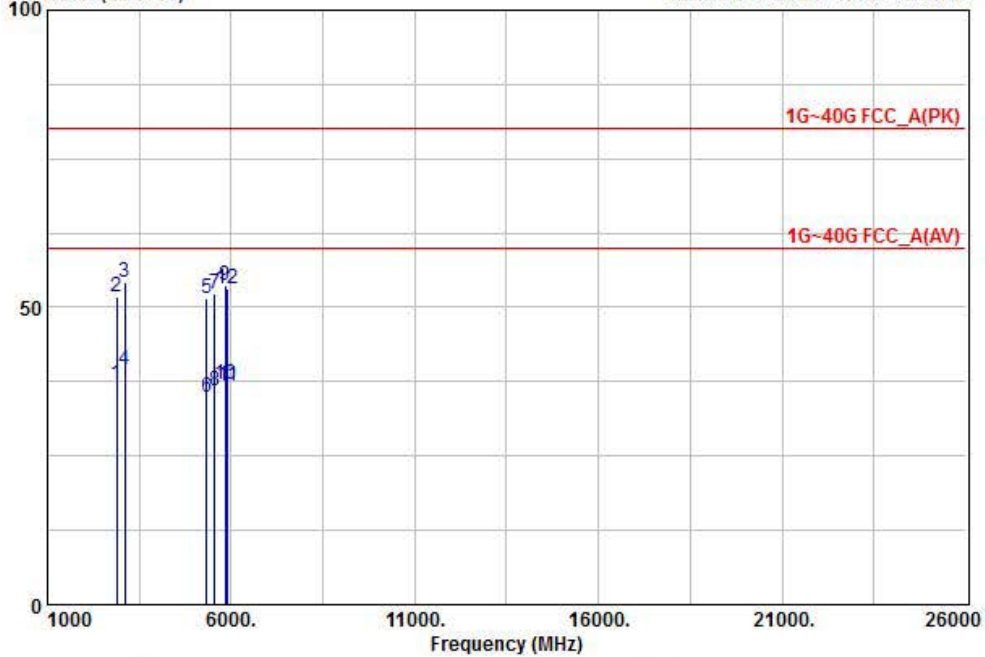

Freq	Reading	C.F	Result	Limit	Margin	Polarity
MHz	dBuV	dB	PK dBuV/m	dBuV/m	dB	
1 2883.60	30.50	6.54	37.04	60.00	22.96	HORIZONTAL
2 2883.60	45.30	6.54	51.84	80.00	28.16	HORIZONTAL
3 3112.50	45.20	9.05	54.25	80.00	25.75	HORIZONTAL
4 3112.50	30.40	9.05	39.45	60.00	20.55	HORIZONTAL
5 5332.80	32.40	19.03	51.43	80.00	28.57	HORIZONTAL
6 5332.80	15.80	19.03	34.83	60.00	25.17	HORIZONTAL
7 5548.60	32.50	19.80	52.30	80.00	27.70	VERTICAL
8 5548.60	16.20	19.80	36.00	60.00	24.00	VERTICAL
9 5842.20	32.80	20.83	53.63	80.00	26.37	VERTICAL
10 5842.20	16.20	20.83	37.03	60.00	22.97	VERTICAL
11 5908.80	15.50	21.26	36.76	60.00	23.24	VERTICAL
12 5908.80	31.80	21.26	53.06	80.00	26.94	VERTICAL

Remarks: C.F (Correction Factor) = Antenna factor + Cable loss - Preamp gain
 Blue : Vertical Black : Horizontal

Radiated Emissions (Above 1 GHz) – 2.4 GHz Zigbee(Middle) mode



EMI Chamber of LTA CO.,LTD.
 4, Songjuro236Beon-gil, Yangji-myeon,
 Yongin-si, Gyeonggi-do, Korea Autho.by NVLAP
 Tel :+82-31-3236008,9 www.ltalab.com
 Fax:+82-31-3236010

EUT/Model No. : IDM22 Test Mode: Wireless mode (MID)
 Tested by : LEE H W Temp/Humi: 24 / 58

Data: 9 File: D:\LTA_e3\3_backup\1GHz 이상\2017\CH1_ABOVE 1GHz_1709-1.EMI (17) Date: 2017-09-27 Time: 10:23:26
 Level (dBuV/m)

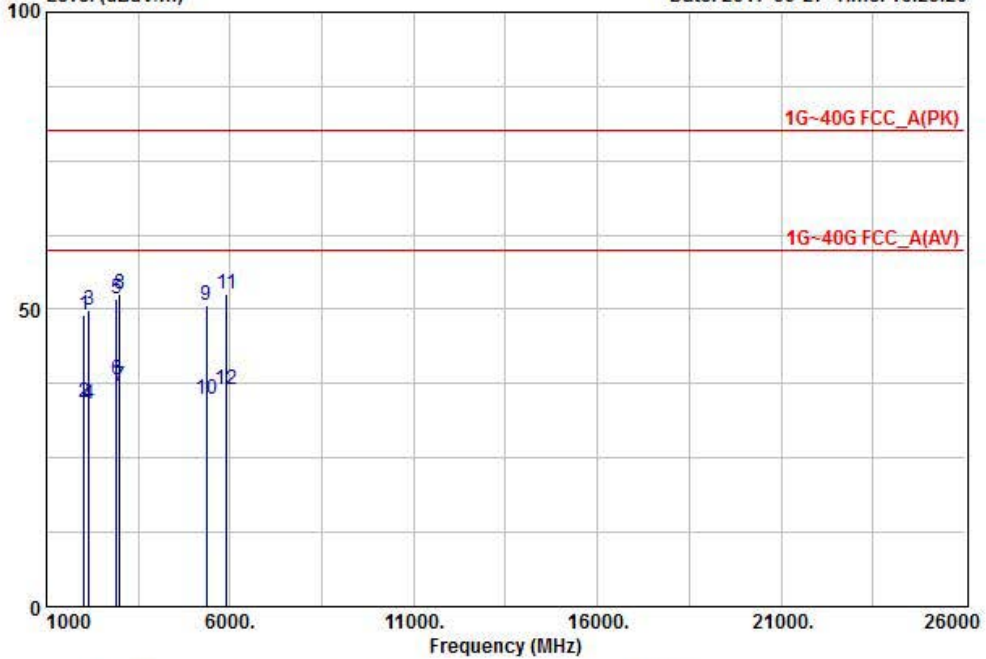

Freq	Reading	C.F	Result	Limit	Margin	Polarity	
MHz	dBuV	dB	PK dBuV/m	dBuV/m	dB		
1	2015.60	47.30	1.65	48.95	80.00	31.05	VERTICAL
2	2015.60	32.80	1.65	34.45	60.00	25.55	VERTICAL
3	2162.80	47.70	2.23	49.93	80.00	30.07	HORIZONTAL
4	2162.80	31.80	2.23	34.03	60.00	25.97	HORIZONTAL
5	2908.60	45.00	6.82	51.82	80.00	28.18	HORIZONTAL
6	2908.60	31.20	6.82	38.02	60.00	21.98	HORIZONTAL
7	2984.50	29.50	7.64	37.14	60.00	22.86	HORIZONTAL
8	2984.50	44.90	7.64	52.54	80.00	27.46	HORIZONTAL
9	5354.60	31.50	19.08	50.58	80.00	29.42	VERTICAL
10	5354.60	15.90	19.08	34.98	60.00	25.02	VERTICAL
11	5904.20	31.50	21.22	52.72	80.00	27.28	VERTICAL
12	5904.20	15.20	21.22	36.42	60.00	23.58	VERTICAL

Remarks: C.F (Correction Factor) = Antenna factor + Cable loss - Preamp gain
 Blue : Vertical Black : Horizontal

Radiated Emissions (Above 1 GHz) – 2.4 GHz Zigbee(High) mode



EMI Chamber of LTA CO.,LTD.
 4, Songjuro236Beon-gil, Yangji-myeon,
 Yongin-si, Gyeonggi-do, Korea Autho.by NVLAP
 Tel :+82-31-3236008,9 www.ltalab.com
 Fax:+82-31-3236010

EUT/Model No. : IDM22

Test Mode: Wireless mode (HIGH)

Tested by : LEE H W

Temp/Humi: 24 / 58

Data: 8 File: D:\LTA_e3\3_backup\1GHz 이상\2017\CH1_ABOVE 1GHz_1709-1.EMI (17) Date: 2017-09-27 Time: 10:20:58

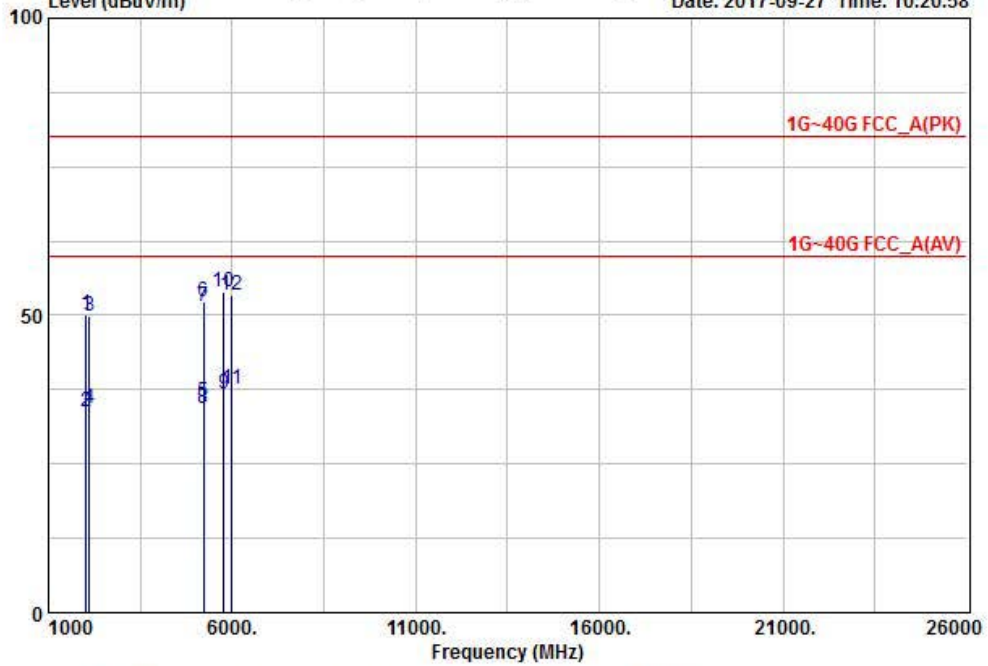

Freq	Reading	C.F	Result	Limit	Margin	Polarity
MHz	dBuV	dB	PK dBuV/m	dBuV/m	dB	
1 2028.60	48.30	1.74	50.04	80.00	29.96	HORIZONTAL
2 2028.60	32.10	1.74	33.84	60.00	26.16	HORIZONTAL
3 2105.30	47.60	2.13	49.73	80.00	30.27	VERTICAL
4 2105.30	32.10	2.13	34.23	60.00	25.77	VERTICAL
5 5216.30	16.80	18.75	35.55	60.00	24.45	VERTICAL
6 5216.30	33.70	18.75	52.45	80.00	27.55	VERTICAL
7 5223.40	32.80	18.72	51.52	80.00	28.48	HORIZONTAL
8 5223.40	15.70	18.72	34.42	60.00	25.58	HORIZONTAL
9 5773.30	16.20	20.45	36.65	60.00	23.35	VERTICAL
10 5773.30	33.50	20.45	53.95	80.00	26.05	VERTICAL
11 5984.30	15.90	21.81	37.71	60.00	22.29	HORIZONTAL
12 5984.30	31.60	21.81	53.41	80.00	26.59	HORIZONTAL

Remarks: C.F (Correction Factor) = Antenna factor + Cable loss - Preamp gain
 Blue : Vertical Black : Horizontal

APPENDIX

TEST EQUIPMENT USED FOR TESTS

	Use	Description	Model No.	Serial No.	Manufacturer	Interval	Last Cal. Date
1	■	Signal Analyzer (9 kHz ~ 30 GHz)	FSV30	100757	R&S	1 year	2017-09-07
2	■	Signal Generator (~3.2 GHz)	8648C	3623A02597	HP	1 year	2017-03-20
3		SYNTHESIZED CW GENERATOR	83711B	US34490456	HP	1 year	2017-03-20
4		Attenuator (3 dB)	8491A	37822	HP	1 year	2017-09-07
5		Attenuator (10 dB)	8491A	63196	HP	1 year	2017-09-07
6	■	EMI Test Receiver (~7 GHz)	ESCI7	100722	R&S	1 year	2017-09-07
7	■	RF Amplifier (~1.3 GHz)	8447D OPT 010	2944A07684	HP	1 year	2017-09-07
8	■	RF Amplifier (1~26.5 GHz)	8449B	3008A02126	HP	1 year	2017-03-21
9	■	Horn Antenna (1~18 GHz)	3115	00114105	ETS	2 year	2016-08-04
10		DRG Horn (Small)	3116B	81109	ETS-Lindgren	2 year	2016-05-03
11	■	DRG Horn (Small)	3116B	133350	ETS-Lindgren	2 year	2016-05-03
12	■	TRILOG Antenna	VULB 9160	9160-3237	SCHWARZBECK	2 year	2017-04-17
13		Temp.Humidity Data Logger	SK-L200TH II A	00801	SATO	1 year	2017-03-21
14		Splitter (SMA)	ZFSC-2-2500	SF617800326	Mini-Circuits	-	-
15	■	DC Power Supply	6674A	3637A01657	Agilent	-	-
16		Frequency Counter	5342A	2826A12411	HP	1 year	2017-03-21
17	■	Power Meter	EPM-441A	GB32481702	HP	1 year	2017-03-20
18	■	Power Sensor	8481A	3318A94972	HP	1 year	2016-12-30
19		Audio Analyzer	8903B	3729A18901	HP	1 year	2017-09-07
20		Modulation Analyzer	8901B	3749A05878	HP	1 year	2017-09-07
21		TEMP & HUMIDITY Chamber	YJ-500	LTAS06041	JinYoung Tech	1 year	2017-09-07
22		Stop Watch	HS-3	812Q08R	CASIO	2 year	2017-03-21
23		LISN	KNW-407	8-1430-1	Kyoritsu	1 year	2017-09-07
24		Two-Lime V-Network	ESH3-Z5	893045/017	R&S	1 year	2017-03-20
25		UNIVERSAL RADIO COMMUNICATION TESTER	CMU200	106243	R&S	1 year	2017-03-20
26		Highpass Filter	WHKX1.5/15G-10SS	74	Wainwright Instruments	1 year	2017-03-20
27		Highpass Filter	WHKX3.0/18G-10SS	118	Wainwright Instruments	1 year	2017-03-20
28		OSP120 BASE UNIT	OSP120	101230	R&S	1 year	2017-03-21
29		Signal Generator(100 kHz ~ 40 GHz)	SMB100A03	177621	R&S	1 year	2017-03-23
30		Signal Analyzer (10 Hz ~ 40 GHz)	FSV40	101367	R&S	1 year	2017-03-21