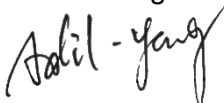
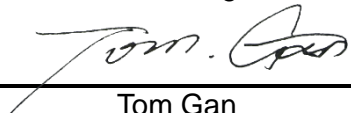

Test Report

Product name : Remote Controller
Trademark : N.A.
Model no...... : HS-8G
Series Model(s)..... : N.A.
FCC ID : 2ANM3HS8G
IC..... : 23165-HS8G
HVIN..... : HS-8G
Report No : C240229043-RF01
Test Standards..... : CFR47 FCC Part 15: Subpart C Section 15.247
CFR47 FCC Part 15: Subpart C Section 15.207
RSS-247 Issue 3
RSS-Gen Issue 5
Applicant : Shenzhen Chuangwei-RGB Electronics Co., Ltd.
Address of applicant : 13F-16F, Unit A, Skyworth Building, Shennan Road, Nanshan District, Shenzhen, China
Manufacturer : Shenzhen Chuangwei-RGB Electronics Co., Ltd.
Manufacturer Address : 13F-16F, Unit A, Skyworth Building, Shennan Road, Nanshan District, Shenzhen, China
Date of Test Date..... : Feb 29, 2024 to Mar 09, 2024
Date of issue..... : Apr 08, 2024
Test result..... : Compliance

Testing Engineer : 
Jeff Fang

Reviewed By : 
Adil Yang

Approved Signatory : 
Tom Gan

The test results in the report only apply to the tested sample. The test report shall be invalid without all the signatures of testing engineers, reviewer and approver. Any objections must be raised to CSIC within 15 days since the date when the report is received. It will not be taken into consideration beyond this limit.

Revision History

Rev.	Issue Date	Revisions	Effect Page	Revised By
00	Apr.08, 2024	Initial Issue	ALL	Adil Yang

Table of Contents

	Page
1. TEST SUMMARY	4
1.1. TEST DESCRIPTION	4
1.2. TEST FACILITY	5
1.3. MEASUREMENT UNCERTAINTY	5
2. GENERAL INFORMATION	6
2.1. GENERAL DESCRIPTION OF EUT	6
2.2. DESCRIPTION OF TEST MODES AND TEST FREQUENCY	7
2.3. MEASUREMENT INSTRUMENTS LIST	8
2.4. DESCRIPTION OF THE TEST MODES.....	10
2.5. TEST SOFTWARE AND POWER LEVEL	11
2.6. BLOCK DIGRAM SHOWING THE CONFIGURATION OF SYSTEM TESTED	11
2.7. DESCRIPTION OF NECESSARY ACCESSORIES AND SUPPORT UNITS	12
2.8. ENVIRONMENTAL CONDITIONS FOR TESTING	12
3. EMC TEST	13
3.1. CONDUCTED EMISSION ON AC MAINS MEASUREMENT	13
3.2. RADIATED SPURIOUS EMISSION MEASUREMENT.....	15
3.3. CONDUCTED SPURIOUS EMISSIONS MEASURED IN 100 KHZ BANDWIDTH MEASUREMENT	20
3.4. CONDUCTED POWER SPECTRAL DENSITY MEASUREMENT	21
3.5. 6DB BANDWIDTH MEASUREMENT	22
3.6. MAXIMUM CONDUCTED OUTPUT POWER MEASUREMENT.....	24
3.7. ANTENNA REQUIREMENT	26
4. TEST PHOTOS	27
5. EUT PHOTOS	28

1. TEST SUMMARY

1.1. TEST DESCRIPTION

Test procedures according to the technical standards:

Item	Clause	Result	Note
Conducted Emission on AC Mains	Part 15.207(a) RSS-Gen 8.8	N/A	
Maximum Conducted Output Power	Part 15.247(b)(3) RSS-247 5.4(d)	PASS	
Radiated Spurious Emission	Part 15.247(c) Part 15.205 RSS-247 3.3	PASS	
Conducted Spurious Emissions Measured in 100 kHz Bandwidth	Part 15.247(d) RSS-247 5.5	PASS	
Conducted Power Spectral Density	Part 15.247(e) RSS-247 5.2(b)	PASS	
6dB Bandwidth	Part 15.247(a)(2) RSS-247 5.2(a)	PASS	
99% Bandwidth	RSS-Gen 6.7	PASS	
Antenna Requirement	Part 15.247(b)(4) Part 15.203	PASS	

Note:

- 1) "N/A" denotes test is not applicable in this Test Report.
- 2) All tests are according to ANSI C63.10-2013.
- 3) The statements of test result on the above are decided by the request of test standard only; the measurement uncertainties are not factored into this compliance determination.
- 4) The information of measurement uncertainty is available upon the customer's request.

1.2. TEST FACILITY

Shenzhen Central Standard International Center Co., Ltd. (CSIC)

Room 201, Building 1, Mogen Fashion Industrial Park, No. 10, Shilongzai Road, Xinshi Community, Dalang Street, Longhua District, Shenzhen.

The test facility is recognized, certified or accredited by the following organizations:

CNAS	Registration No.: L11671	
FCC	Registration No.: 0031378433	Designation Number: CN1317
IC	CAB identifier: CN0051	
A2LA	Lab Cert. No.: 6426.01	

1.3. MEASUREMENT UNCERTAINTY

The estimated combined standard uncertainty for radiated emissions and conducted emissions measurements as below table.

Below is the best measurement capability for Shenzhen Central Standard International Center Co., Ltd.

Test Items	Measurement Uncertainty	Notes
RF output power, conducted	$\pm 0.59\text{dB}$	(1)
Unwanted Emissions, conducted	$\pm 2.20\text{dB}$	(1)
Power spectral density, conducted	$\pm 1.08\text{dB}$	(1)
Bandwidth, conducted	$\pm 80\text{Hz}$	(1)
All emissions, radiated 9KHz-30MHz	$\pm 4.44\text{dB}$	(1)
All emissions, radiated 30-1GHz	$\pm 4.48\text{dB}$	(1)
All emissions, radiated 1G-6GHz	$\pm 5.08\text{dB}$	(1)
All emissions, radiated >6G	$\pm 5.08\text{dB}$	(1)
Conducted Emission (9KHz-150KHz)	$\pm 1.60\text{dB}$	(1)
Conducted Emission (150KHz-30MHz)	$\pm 3.68\text{dB}$	(1)

Note(1): This uncertainty represents an expanded uncertainty expressed at approximately the 95% confidence level using a coverage factor of $k=2$.

2. GENERAL INFORMATION

2.1. GENERAL DESCRIPTION OF EUT

EUT(Product Specifications)	
Product Name:	Remote Controller
Trademark:	N.A.
Model:	HS-8G
Series Model(s):	N.A.
Power supply:	DC 3V for 2*AAA Battery
Hardware version:	Skyworth-K27-2672C-V1.2.0
Software version:	V0.1.0
Technical Specification of Bluetooth LE	
Frequency Range:	2402 MHz to 2480 MHz
Type of Modulation:	GFSK
Channel Number:	40 channels
Data Rate:	1 Mbps, 2 Mbps
Channel Separation:	2 MHz
Antenna Type:	PIFA Antenna
Antenna Gain:	2.68 dBi
Product factory information	
Name of factory 1:	N.A.
Address of factory 1:	N.A.
Remark:	

Note:

1. For a more detailed features description, please refer to the manufacture's specifications or the user's manual.
2. Full tests were applied to the sample(C240229043-Y01/01) only in this document.

2.2. DESCRIPTION OF TEST MODES AND TEST FREQUENCY

The EUT has been tested under typical operating condition. The Applicant provides communication tools software to control the EUT for staying in continuous transmitting mode for testing.

Operation Frequency List for Bluetooth Low Energy:

Channel	Frequency (MHz)	Channel	Frequency (MHz)
0	2402.00	10	2422.00
1	2404.00	11	2424.00
2	2406.00	12	2426.00
3	2408.00	13	2428.00
4	2410.00	14	2430.00
5	2412.00	15	2432.00
6	2414.00	16	2434.00
7	2416.00	17	2436.00
8	2418.00	18	2438.00
9	2420.00	19	2440.00
20	2442.00	30	2462.00
21	2444.00	31	2464.00
22	2446.00	32	2466.00
23	2448.00	33	2468.00
24	2450.00	34	2470.00
25	2452.00	35	2472.00
26	2454.00	36	2474.00
27	2456.00	37	2476.00
28	2458.00	38	2478.00
29	2460.00	39	2480.00

For Bluetooth Low Energy		
Test Channel	EUT Channel	Test Frequency (MHz)
lowest	CH00	2402
middle	CH19	2440
highest	CH39	2480

2.3. MEASUREMENT INSTRUMENTS LIST

RF Connected Test					
Item	Test Equipment	Manufacturer	Model No.	Serial No.	Calibrated until
1	Spectrum Analyzer	Agilent	N9020A	MY50200391	May. 31, 2024
2	Power sensor	KEYSIGHT	U2021XA	MY55080015	May. 31, 2024
3	Power sensor	KEYSIGHT	U2021XA	MY54250016	May. 31, 2024
4	Power sensor	KEYSIGHT	U2021XA	MY54250020	May. 31, 2024
5	Power sensor	KEYSIGHT	U2021XA	MY54210030	May. 31, 2024
6	Vector Signal Generator	Agilent	N5182A	MY50140130	May. 31, 2024
7	Signal generator	Agilent	SML03	100925	May. 31, 2024
8	Power sensor Box	MWRFTest	N/A	N/A	N/A
9	RF Switch Box	MWRFTest	MW100-RFCB	N/A	N/A
10	MTS 8310	MWRFTest	V: 2.0.0.0		

Radiation Test equipment					
Item	Test Equipment	Manufacturer	Model No.	Serial No.	Calibrated until
1	EMI TEST RECEIVER	R&S	ESIB26	100342	May. 31, 2024
2	Amplifier	HP	8447F	2634A02050	May. 31, 2024
3	Amplifier	COM-MW	DPA8-1000-18000-1012	8220837	Mar. 19, 2024
4	Amplifier	SKET	LNPA_1840-50	SK201801801	Mar. 05, 2025
5	Loop Antenna	SCHNARZBEC K	FMZB1519B	00023	Nov. 12, 2025
6	Bilog Antenna	Schwarzbeck	VULB-9168	VULB9168-250	Jul. 25, 2025
7	Horn Antenna	AARONIAAG	Powerlog 70180	3980	Jul. 04, 2025
8	Horn Antenna	COM-MW	ZLB7-18-40G-777	3231081	Mar. 27, 2024
9	3M Chamber	Maor	9*6*6	--	Mar. 01, 2026
10	EZ-EMC	Farad	V3.1		

Mains Terminal Disturbance Voltage Test equipment					
Item	Test Equipment	Manufacturer	Model No.	Serial No.	Calibrated until
1	EMI Test Receiver	R&S	ESCI3	101413	Apr. 04, 2024
2	LISN	R&S	ENV216	100002	Apr. 16, 2024
3	LISN	MEB	NNB 42	--	May. 31, 2024
4	Shelding Room	Maor	8*4*3	--	Mar. 01, 2025
8	EZ-EMC	Fara	V3.1		

Note:

- 1) The cable loss has calculated in test result which connection between each test instruments.

2.4. DESCRIPTION OF THE TEST MODES

To investigate the maximum EMI emission characteristics generated from EUT, the test system was pre-scanning tested based on the consideration of following EUT operation mode or test configuration mode which possibly have effect on EMI emission level. Each of these EUT operation mode(s) or test configuration mode(s) mentioned above was evaluated respectively.

Worst Mode	Description	Data Rate
Mode 1	TX CH0	1 Mbps
Mode 2	TX CH19	1 Mbps
Mode 3	TX CH39	1 Mbps
Mode 4	TX CH0	2 Mbps
Mode 5	TX CH19	2 Mbps
Mode 6	TX CH39	2 Mbps

Note:

- 1) The measurements are performed at the high, middle, low available channels.
- 2) All the bit rate of transmitter have been tested and found the lowest rate is found to be the worst case and recorded.
- 3) This test was performed with EUT in X, Y, Z position and worst case was found when EUT in X position.
- 4) For radiated emission above 1 GHz test, 1GHz-25GHz have been pre-tested and in this report only recorded the worst case. The remaining spurious points are all below the limit value of 20dB.

2.5. TEST SOFTWARE AND POWER LEVEL

During testing channel & power controlling software provided by the customer was used to control the operating channel as well as the output power level.

RF Function	Type	Mode Or Modulation type	Ant Gain(dBi)	Power Class	Software For Testing
Bluetooth	BLE	GFSK	2.68	default	RTL8762x_RF TestTool_v1.0 .2.7

Note: The power class cannot be manually adjusted in the software.

2.6. BLOCK DIGRAM SHOWING THE CONFIGURATION OF SYSTEM TESTED

a. Radiated Spurious Emission Test

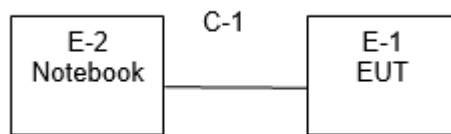

b. Conducted Emission Test

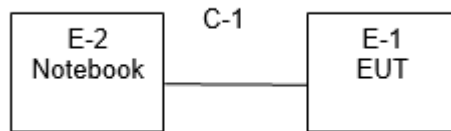

2.7. DESCRIPTION OF NECESSARY ACCESSORIES AND SUPPORT UNITS

The EUT has been tested as an independent unit together with other necessary accessories or support units. The following support units or accessories were used to form a representative test configuration during the tests.

Necessary accessories					
Item	Equipment	Mfr/Brand	Model/Type No.	Serial No.	Note
N/A	N/A	N/A	N/A	N/A	N/A

Support units					
Item	Equipment	Mfr/Brand	Model/Type No.	Serial No.	Note
E-2	Notebook	DELL	Vostro 3400	N/A	N/A
E-3	Serial board	Waveshare	FT232	N/A	N/A
C-1	USB Cable	N/A	100cm	N/A	N/A

Note:

- 1) The support equipment was authorized by Declaration of Confirmation.
- 2) For detachable type I/O cable should be specified the length in cm in 『Length』 column.

2.8. ENVIRONMENTAL CONDITIONS FOR TESTING

Test Item	Temperature (°C)	Relative Humidity (%)	Test Voltage	Tested by
Radiated Spurious Emission	24.8	57	DC 3V	Jeff Fang
Conducted Spurious Emissions Measured in 100 kHz Bandwidth	25.9	48	DC 3V	Jeff Fang
Conducted Power Spectral Density	25.9	48	DC 3V	Jeff Fang
99% Bandwidth	25.9	48	DC 3V	Jeff Fang
6dB Bandwidth	25.9	48	DC 3V	Jeff Fang
Maximum Conducted Output Power	25.9	48	DC 3V	Jeff Fang

3. EMC TEST

3.1. Conducted Emission on AC Mains Measurement

Limit

Operating frequency band. In case the emission fall within the restricted band specified on Part 207(a) and RSS-Gen 8.8 limit in the table below has to be followed.

FREQUENCY (MHz)	Conducted Emission limit (dBuV)	
	Quasi-peak	Average
0.15 - 0.5	66 - 56 *	56 - 46 *
0.5 - 5	56	46
5 - 30	60	50

Note:

- 1) The tighter limit applies at the band edges.
- 2) The limit of “ * ” marked band means the limitation decreases linearly with the logarithm of the frequency in the range.

The following table is the setting of the receiver.

Receiver Parameters	Setting
Attenuation	10 dB
Start Frequency	0.15 MHz
Stop Frequency	30 MHz
RBW	9 kHz

Test Procedure

- a) The EUT was 0.8 meters from the horizontal ground plane and 0.4 meters from the vertical ground plane with EUT being connected to the power mains through a line impedance stabilization network (LISN). All other support equipment's powered from additional LISN(s). The LISN provide 50 Ohm/ 50uH of coupling impedance for the measuring instrument.
- b) Interconnecting cables that hang closer than 40 cm to the ground plane shall be folded back and forth in the center forming a bundle 30 to 40 cm long.
- c) I/O cables that are not connected to a peripheral shall be bundled in the center. The end of the cable may be terminated, if required, using the correct terminating impedance. The overall length shall not exceed 1 m.
- d) LISN at least 80 cm from nearest part of EUT chassis.
- e) For the actual test configuration, please refer to the related Item –EUT Test Photos.

Test Setup

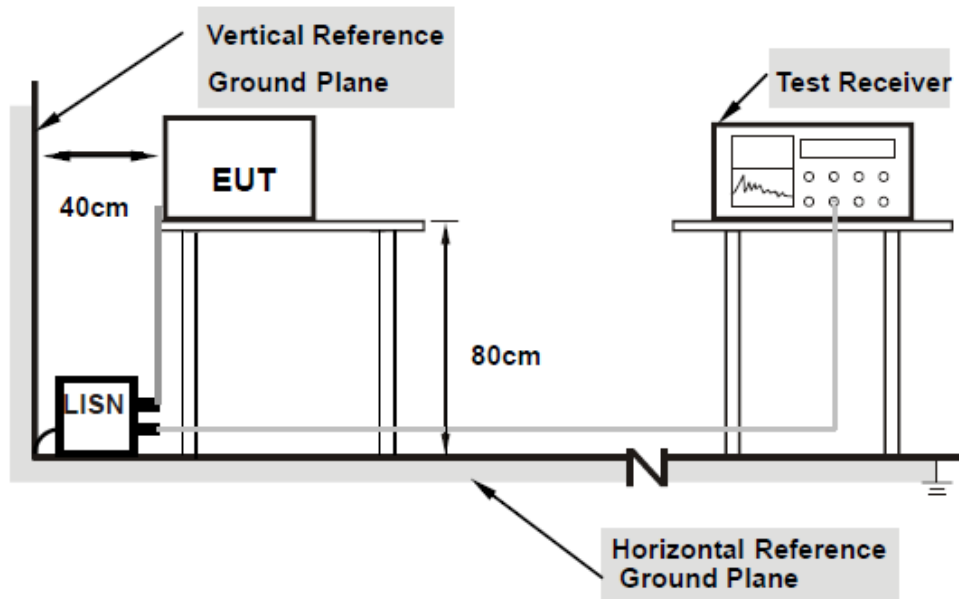

Note:

- 1) Support units were connected to second LISN.
- 2) Both of LISNs (AMN) are 80 cm from EUT and at least 80 from other units and other metal planes

EUT OPERATING CONDITIONS

The EUT was configured for testing in a typical fashion (as a customer would normally use it). The EUT has been programmed to continuously transmit during test. This operating condition was tested and used to collect the included data.

Data Sample

No.	Frequency (MHz)	Reading (dBuV)		Correct Factor (dB)	Result (dBuV)		Limit (dBuV)		Margin (dB)		Remark
		QP	AVG		QP	AVG	QP	AVG	QP	AVG	
x	xx.xxxx	39.01	34.65	9.78	48.79	44.43	60	50	-11.21	-5.57	Pass/fail

Correction Factor = insertion loss of LISN + cable loss;

Reading = Reading Amplitude in the instrument;

Result = Correction Factor + Reading;

Margin = Result – Limit.

Test Results

N/A

3.2. Radiated Spurious Emission Measurement

Limit

In any 100 kHz bandwidth outside the operating frequency band. In case the emission fall within the Restricted band specified on Part15.205 (a)&209(a) and RSS-247 3.3 limit in the table and according to ANSI C63.10-2013 and RSS-Gen below has to be followed.

LIMITS OF RADIATED EMISSION MEASUREMENT (Below 1GHz)

Frequencies (MHz)	Field Strength (micorvolts/meter)	Measurement Distance (meters)
0.009~0.490	2400/F(KHz)	300
0.490~1.705	24000/F(KHz)	30
1.705~30.0	30	30
30~88	100	3
88~216	150	3
216~960	200	3
Above 960	500	3

LIMITS OF RADIATED EMISSION MEASUREMENT (Above 1GHz)

FREQUENCY (MHz)	(dBuV/m) (at 3M)	
	PEAK	AVERAGE
Above 1000	74	54

Notes:

- 1) The limit for radiated test was performed according to FCC PART 15C, RSS-247 and RSS-Gen.
- 2) The tighter limit applies at the band edges.
- 3) Emission level (dBuV/m)=20log Emission level (uV/m).

LIMITS OF RESTRICTED FREQUENCY BANDS

For FCC:

FREQUENCY (MHz)	FREQUENCY (MHz)	FREQUENCY (MHz)	FREQUENCY (GHz)
0.090-0.110	16.42-16.423	399.9-410	4.5-5.15
0.495-0.505	16.69475-16.69525	608-614	5.35-5.46
2.1735-2.1905	16.80425-16.80475	960-1240	7.25-7.75
4.125-4.128	25.5-25.67	1300-1427	8.025-8.5
4.17725-4.17775	37.5-38.25	1435-1626.5	9.0-9.2
4.20725-4.20775	73-74.6	1645.5-1646.5	9.3-9.5
6.215-6.218	74.8-75.2	1660-1710	10.6-12.7
6.26775-6.26825	108-121.94	1718.8-1722.2	13.25-13.4
6.31175-6.31225	123-138	2200-2300	14.47-14.5
8.291-8.294	149.9-150.05	2310-2390	15.35-16.2
8.362-8.366	156.52475-156.52525	2483.5-2500	17.7-21.4
8.37625-8.38675	156.7-156.9	2690-2900	22.01-23.12
8.41425-8.41475	162.0125-167.17	3260-3267	23.6-24.0
12.29-12.293	167.72-173.2	3332-3339	31.2-31.8
12.51975-12.52025	240-285	3345.8-3358	36.43-36.5
12.57675-12.57725	322-335.4	3600-4400	Above 38.6
13.36-13.41			

For IC:

FREQUENCY (MHz)	FREQUENCY (MHz)	FREQUENCY (MHz)	FREQUENCY (GHz)
0.090-0.110	13.36-13.41	960-1427	9.0-9.2
0.495-0.505	16.42-16.423	1435-1626.5	9.3-9.5
2.1735-2.1905	16.69475-16.69525	1645.5-1646.5	10.6-12.7
3.020-3.026	16.80425-16.80475	1660-1710	13.25-13.4
4.125-4.128	25.5-25.67	1718.8-1722.2	14.47-14.5
4.17725-4.17775	37.5-38.25	2200-2300	15.35-16.2
4.20725-4.20775	73-74.6	2310-2390	17.7-21.4
5.677-5.683	74.8-75.2	2483.5-2500	22.01-23.12
6.215-6.218	108-138	2655-2900	23.6-24.0
6.26775-6.26825	149.9-150.05	3260-3267	31.2-31.8
6.31175-6.31225	156.52475-156.52525	3332-3339	36.43-36.5
8.291-8.294	156.7-156.9	3345.8-3358	Above 38.6
8.362-8.366	162.0125-167.17	3500-4400	--
8.37625-8.38675	167.72-173.2	4500-5150	--
8.41425-8.41475	240-285	5350-5460	--
12.29-12.293	322-335.4	7250-7750	--
12.51975-12.52025	399.9-410	8025-8500	--
12.57675-12.57725	608-614	--	--

For Radiated Emission	
Spectrum Parameter	Setting
Attenuation	Auto
Detector	Peak/QP/AVG
Start Frequency	9 KHz/150KHz(Peak/QP/AVG)
Stop Frequency	150KHz/30MHz(Peak/QP/AVG)
RB / VB (emission in restricted band)	200Hz (From 9kHz to 0.15MHz)/
	9KHz (From 0.15MHz to 30MHz);
	200Hz (From 9kHz to 0.15MHz)/
	9KHz (From 0.15MHz to 30MHz)
Attenuation	Auto
Detector	Peak/QP
Start Frequency	30 MHz(Peak/QP)
Stop Frequency	1000 MHz (Peak/QP)
RB / VB (emission in restricted band)	120 kHz / 300 kHz
Attenuation	Auto
Detector	Peak/AVG
Start Frequency	1000 MHz(Peak/AVG)
Stop Frequency	10th carrier hamonic(Peak/AVG)
RB / VB (emission in restricted band)	1 MHz / 3 MHz(Peak)
	1 MHz/1/T MHz(AVG)

For Restricted band	
Spectrum Parameter	Setting
Detector	Peak/AVG
Start/Stop Frequency	Lower Band Edge: 2310 to 2410 MHz
	Upper Band Edge: 2476 to 2500 MHz
RB / VB	1 MHz / 3 MHz(Peak)
	1 MHz/1/T MHz(AVG)
Receiver Parameter	Setting
Attenuation	Auto
Start ~ Stop Frequency	9kHz~90kHz / RB 200Hz for Peak & AVG
Start ~ Stop Frequency	90kHz~110kHz / RB 200Hz for QP
Start ~ Stop Frequency	110kHz~490kHz / RB 200Hz for Peak & AVG
Start ~ Stop Frequency	490kHz~30MHz / RB 9kHz for QP
Start ~ Stop Frequency	30MHz~1000MHz / RB 120kHz for QP

Test Procedure

- a) The measuring distance of at 3 m shall be used for measurements at frequency 0.009MHz up to 1GHz,and above 1GHz.
- b) The EUT was placed on the top of a rotating table 0.8 meters (above 1GHz is 1.5 m) above the ground at a 3 meter anechoic chamber test site. The table was rotated 360 degrees to determine the position of the highest radiation.
- c) The height of the equipment shall be 0.8 m(above 1GHz is 1.5 m); the height of the test antenna shall vary between 1 m to 4 m. horizontal and vertical polarizations of the antenna are set to make the measurement.
- d) The initial step in collecting conducted emission data is a spectrum analyzer peak detector mode pre-scanning the measurement frequency range. Significant peaks are then marked and then QuasiPeak detector mode re-measured.
- e) If the Peak Mode measured value compliance with and lower than Quasi Peak Mode Limit, the EUT shall be deemed to meet QP Limits and then no additional QP Mode measurement performed.
- f) For the actual test configuration, please refer to the related Item –EUT Test Photos.

Note:

Both horizontal and vertical antenna polarities were tested and performed pretest to three orthogonal axis. The worst case emissions were reported.

DEVIATION FROM TEST STANDARD

No deviation.

Test Setup

1. Radiated Emission Test-Up Frequency Below 30MHz

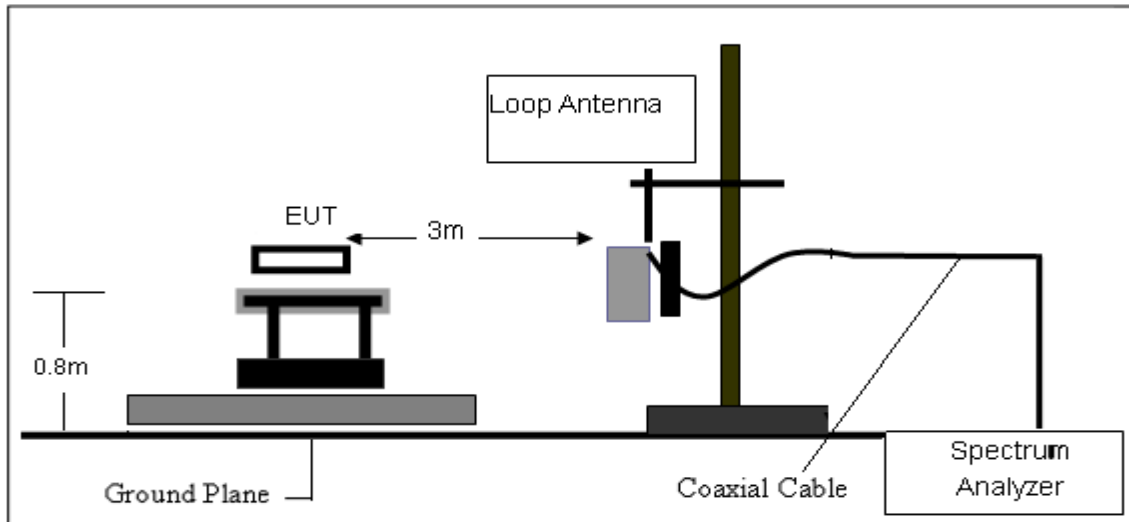

2. Radiated Emission Test-Up Frequency 30MHz~1GHz

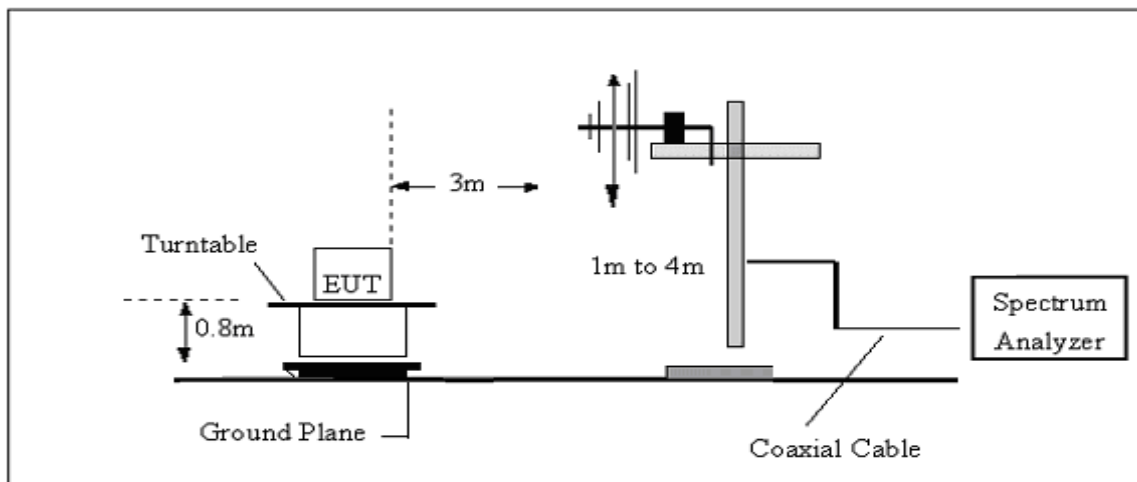

3. Radiated Emission Test-Up Frequency Above 1GHz

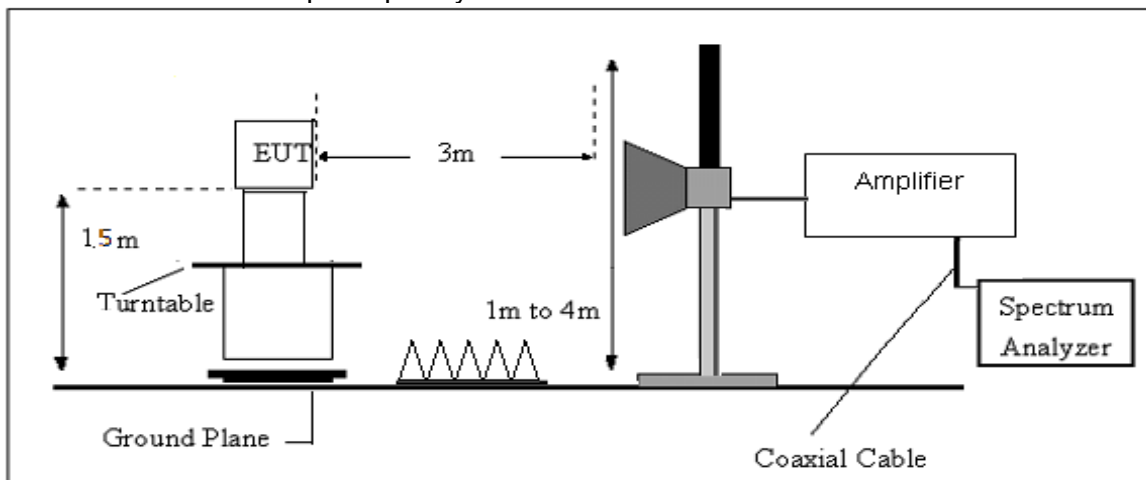

EUT OPERATING CONDITIONS

The EUT tested system was configured as the statements of 2.5 Unless otherwise a special operating condition is specified in the follows during the testing.

Data Sample

Below 1GHz:

No.	Frequency (MHz)	Reading (dBuV)	Correct Factor(dB/m)	Result (dBuV/m)	Limit (dBuV/m)	Margin (dB)	Remark
x	xxx.xxxx	42.72	2.48	45.20	74.00	-28.80	QP

Correction Factor = antenna factor + cable loss – amplifier gain;

Reading = Reading Amplitude in the instrument;

Result = Correction Factor + Reading;

Margin = Result – Limit.

Above 1GHz:

No.	Frequency (MHz)	Reading (dBuV)	Correct Factor(dB/m)	Result (dBuV/m)	Limit (dBuV/m)	Margin (dB)	Remark
1	xxxx.xxx	42.72	2.48	45.20	74.00	-28.80	peak
2	xxxx.xxx	32.75	2.48	35.23	54.00	-18.77	AVG

Correction Factor = antenna factor + cable loss – amplifier gain;

Reading = Reading Amplitude in the instrument;

Result = Correction Factor + Reading;

Margin = Result – Limit.

Test Result

Pass

Please refer of Appendix A.

3.3. Conducted Spurious Emissions Measured in 100 kHz Bandwidth Measurement

Limit

According to FCC section 15.247(d) and RSS-247 5.5, in any 100kHz bandwidth outside the frequency band in which the spread spectrum or digitally modulated intentional radiator is operating, the radio frequency power that is produced by the intentional radiator shall be at least 20dB below that in the 100kHz bandwidth within the band that contains the highest level of the desired power, based on either an RF conducted or a radiated measurement.

Test Procedure

Spectrum Parameter	Setting
Detector	Peak
Start/Stop Frequency	30 MHz to 10th carrier harmonic
RB / VB (emission in restricted band)	100 KHz/300 KHz
Trace-Mode:	Max hold
For Band edge	
Spectrum Parameter	Setting
Detector	Peak
Start/Stop Frequency	Lower Band Edge: 2327 – 2427 MHz
	Upper Band Edge: 2447 – 2547 MHz
RB / VB (emission in restricted band)	100 KHz/300 KHz
Trace-Mode:	Max hold

Test Configuration

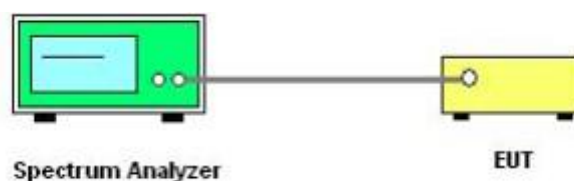

The EUT is connected to the Spectrum Analyzer; the RF load attached to the EUT antenna terminal is 50Ohm; the path loss as the factor is calibrated to correct the reading. Make the measurement with the spectrum analyzer's resolution bandwidth (RBW) = 100 kHz. In order to make an accurate measurement, set the span greater than RBW.

EUT OPERATION CONDITIONS

The EUT tested system was configured as the statements of 2.5 Unless otherwise a special operating condition is specified in the follows during the testing.

Test Results

Pass

Please refer of Appendix A.

3.4. Conducted Power Spectral Density Measurement

Limits

Test Item	Limit	Frequency Range (MHz)	Result
Power Spectral Density	$\leq 8 \text{ dBm(RBW} \geq 3\text{KHz)}$	2400-2483.5	PASS

Test Procedure

1. Set analyzer center frequency to DTS channel center frequency.
2. Set the span to 1.5 times the DTS channel bandwidth.
3. Set the RBW to: $100 \text{ kHz} \geq \text{RBW} \geq 3 \text{ kHz}$.
4. Set the VBW $\geq 3 \times \text{RBW}$.
5. Detector = peak.
6. Sweep time = auto couple.
7. Trace mode = max hold.
8. Allow trace to fully stabilize.
9. Use the peak marker function to determine the maximum amplitude level.
10. If measured value exceeds limit, reduce RBW (no less than 3 kHz) and repeat.

TEST SETUP

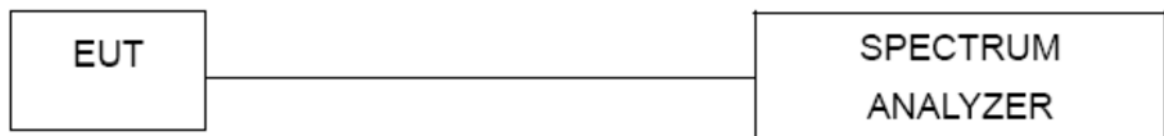

EUT OPERATION CONDITIONS

The EUT tested system was configured as the statements of 2.5 Unless otherwise a special operating condition is specified in the follows during the testing.

Test Results

Pass

Please refer of Appendix A.

3.5. 6dB BANDWIDTH Measurement

Limits

Test Item	Limit	Frequency Range (MHz)	Result
Bandwidth	≥500KHz	2400-2483.5	PASS

Test Procedure

The automatic bandwidth measurement capability of an instrument may be employed using the X dB bandwidth mode with X set to 6 dB, if the functionality described above (i.e., RBW = 100 kHz, VBW- 3RBW, peak detector with maximum hold) is implemented by the instrumentation function. When using this capability, care shall be taken so that the bandwidth measurement is not influenced by any intermediate power nulls in the fundamental emission that might be- 6 dB.

TEST SETUP



EUT OPERATION CONDITIONS

The EUT tested system was configured as the statements of 2.5 Unless otherwise a special operating condition is specified in the follows during the testing.

Test Results

Pass

Please refer of Appendix A.

3.6. 99% BANDWIDTH Measurement

Limits

Section	Test Item	Limit	Frequency Range (MHz)
RSS-Gen 6.7	99% Bandwidth	--	2400-2483.5

Test Procedure

The EUT was operating in Bluetooth mode and controlled its channel. Printed out the test result from the

spectrum by hard copy function.

The RF output of EUT was connected to the spectrum analyzer by RF cable and attenuator. The path loss was compensated to the results for each measurement.

Set to the maximum power setting and enable the EUT transmit continuously

Set RBW = 1%-5% OBW(43KHz).

Set the video bandwidth (VBW) =130 kHz.

Set Span=4MHz

Set Detector = Peak.

Set Trace mode = max hold.

Set Sweep = auto couple.

Allow the trace to stabilize.

Use the 99 % power bandwidth function of the instrument.

Measure the maximum width of the emission.

Measure and record the results in the test report.

TEST SETUP



EUT OPERATION CONDITIONS

The EUT tested system was configured as the statements of 2.5 Unless otherwise a special operating condition is specified in the follows during the testing.

Test Results

Pass

Please refer of Appendix A.

3.7. Maximum Conducted Output Power Measurement

Limits

Section	Test Item	Limit	Frequency Range (MHz)
15.247 (b)(3)	Output Power	1 watt or 30dBm	2400-2483.5
RSS-247 5.4(d) RSS-Gen 6.12	EIRP	36dBm	2400-2483.5

Test Procedure

Some regulatory agencies permit the maximum conducted (average) output power to be measured as an alternative to the maximum peak conducted output power for determining compliance to the limit. When this option is exercised, the measured power is to be referenced to the OBW rather than to the DTS bandwidth (see 11.2 for definitions and 6.9.2 for measurement guidance).

When using a spectrum analyzer or EMI receiver to perform these measurements, it shall be capable of utilizing a number of measurement points in each sweep that is greater than or equal to twice the span / RBW, to set a bin-to-bin spacing of $\leq RBW / 2$ so that narrowband signals are not lost between frequency bins. If possible, configure or modify the operation of the EUT so that it transmits continuously at its maximum power control level (see 11.6).

The intent is to test at 100% duty cycle; however, a small reduction in duty cycle (to no lower than 98%) is permitted, if required by the EUT for amplitude control purposes. Manufacturers are expected to provide software to the test laboratory to permit such continuous operation.

If continuous transmission (or at least 98% duty cycle) cannot be achieved because of hardware limitations (e.g., overheating), the EUT shall be operated at its maximum power control level, with the transmit duration as long as possible, and the duty cycle as high as possible during which sweep triggering/signal gating techniques may be used to perform the measurement over the transmission duration.

Measurement using a power meter (PM):

1. Method AVGPM:

Method AVGPM is a measurement using an RF average power meter, as follows:

a) As an alternative to spectrum analyzer or EMI receiver measurements, measurements may be performed using a wideband RF power meter with a thermocouple detector or equivalent if all of the conditions listed below are satisfied:

- 1) The EUT is configured to transmit continuously, or to transmit with a constant duty cycle.
- 2) At all times when the EUT is transmitting, it shall be transmitting at its maximum power control level.
- 3) The integration period of the power meter exceeds the repetition period of the transmitted signal by at least a factor of five.

b) If the transmitter does not transmit continuously, measure the duty cycle, D, of the transmitter output signal as described in 11.6.

c) Measure the average power of the transmitter. This measurement is an average over both the ON and OFF periods of the transmitter.

d) Adjust the measurement in dBm by adding $[10 \log (1 / D)]$, where D is the duty cycle.

2. Method AVGPM-G:

Method AVGPM-G is a measurement using a gated RF average power meter.

Alternatively, measurements may be performed using a wideband gated RF power meter provided that the gate parameters are adjusted such that the power is measured only when the EUT is transmitting at its maximum power control level. Because the measurement is made only during the ON time of the transmitter, no duty cycle correction factor is required.

TEST SETUP

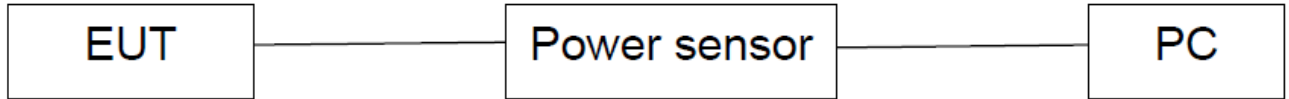

EUT OPERATION CONDITIONS

The EUT tested system was configured as the statements of 2.5 Unless otherwise a special operating condition is specified in the follows during the testing.

Test Results

Pass

Please refer of Appendix A.

3.8. ANTENNA REQUIREMENT

STANDARD REQUIREMENT

According to the manufacturer declared, the EUT has one PIFA antenna, the directional gain of antenna is 2.68 dBi, and the The antenna and other components are all on the same PCB and cannot be replaced. Therefore, the EUT is considered sufficient to comply with the provision.

EUT ANTENNA

The EUT antenna is PIFA antenna. It comply with the standard requirement.

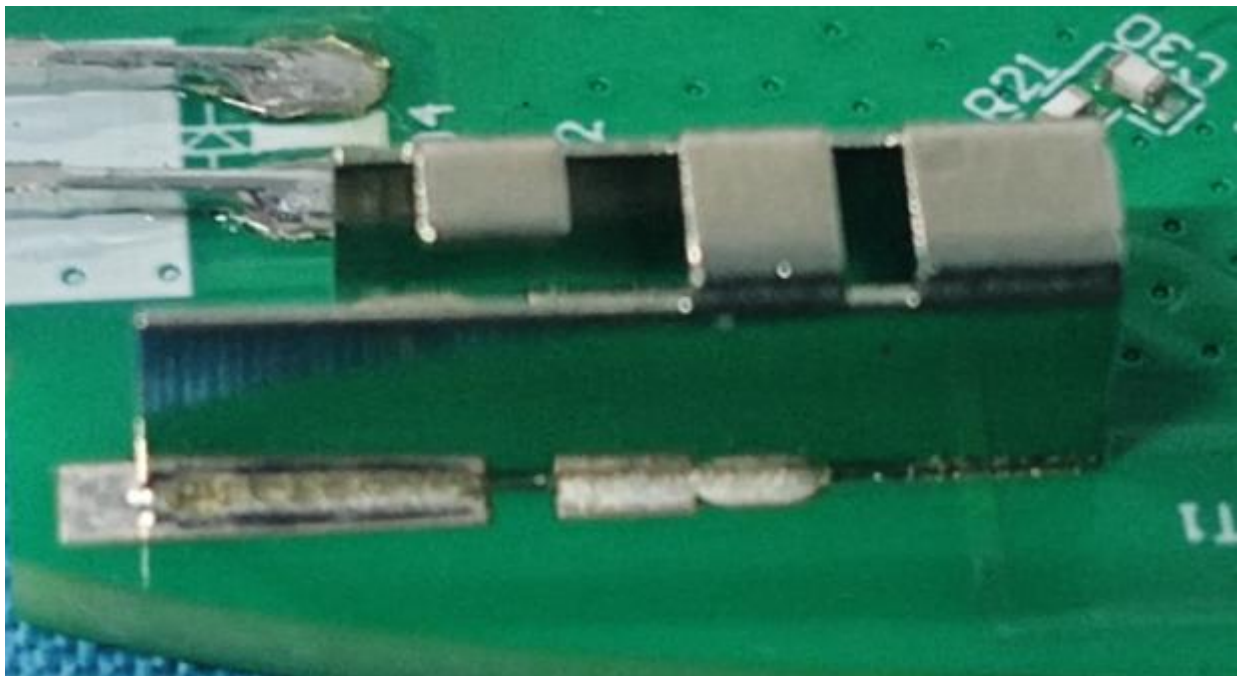

4. TEST PHOTOS

Please refer of Appendix D Test Setup.

5. EUT PHOTOS

External Photos Please refer of Appendix B and Internal Photos Please refer of Appendix C.

*****THE END*****