

**TEST REPORT**

Equipment Shortwave transceiver

XIEGU

Trademark



FCC ID 2ANLH-G1M

Model No. G1M

Report No. CTB210317015RFX

Applicant Chongqing Xiegu Technology Co. , Ltd.

7-6 Incubator Building, No.256, Fangzheng Avenue, Shuitu High-tech park, Beibei district, Chongqing, China

Manufacturer Chongqing Xiegu Technology Co. , Ltd.

7-6 Incubator Building, No.256, Fangzheng Avenue, Shuitu High-tech park, Beibei district, Chongqing, China

Prepared by Shenzhen CTB Testing Technology Co., Ltd.

Floor 1&amp;2, Building A, No. 26 of Xinhe Road, Xinqiao Street, Baoan District, Shenzhen China

Tel: 086-4008-707-283

Fax: 086-0755-23208027

Date of Receipt Mar. 09, 2021

Date of Test(s) Mar. 10, 2021 ~ Mar. 16, 2021

Date of Issue Mar. 17, 2021

Test Standard(s) CFR47, FCC Part 15 Subpart B, ANSI C63.4: 2014

In the configuration tested, the EUT complied with the standards specified above.

Producer :



Bin Mei / Engineer

Date : Mar. 17, 2021

Signatory :

  
Rita Xiao / Director

Date : Mar. 17, 2021

**Note:** The results shown in this test report refer only to the sample(s) tested unless otherwise stated. This test report shall not be reproduced except in full, without prior written approval of CTB. This document may be altered or revised by CTB, personnel only, and shall be noted in the revision of the document.

## Revision History

Edition No.	Date of Revision	Revision Summary	Report Number
0	Mar. 17, 2021	Original Report	CTB210317015RFX

### Table of Contents

1.	GENERAL INFORMATION .....	4
1.1.	Description of EUT .....	4
2.	TEST SUMMARY .....	5
3.	FACILITIES .....	6
3.1.	Test Facility .....	6
3.2.	Test Instruments.....	6
4.	Measurement uncertainty .....	7
4.1.	Operating condition of EUT.....	7
4.2.	Test conditions.....	7
4.3.	DESCRIPTION OF TEST SETUP.....	7
5.	Conducted Emission .....	8
5.1.	Limit.....	8
5.2.	Test setup.....	8
5.3.	EMI Test Receiver Setup.....	8
5.4.	Test procedure.....	9
5.5.	Test results.....	9
6.	Radiated emissions .....	10
6.1.	Limit.....	10
6.2.	Test setup.....	10
6.3.	Test procedure.....	11
6.4.	Corrected Amplitude & Margin Calculation .....	11
6.5.	Test results.....	11
7.	Photographs of test setup .....	16
8.	Photographs of EUT.....	17

# 1. GENERAL INFORMATION

## 1.1. Description of EUT

Equipment	Shortwave transceiver
Trade Mark	XIEQU 
Model Name	G1M
Serial No.	N/A
Model Difference	N/A
Receive frequency	0.5-30MHz
I/O Port	N/A
EUT Power Rating	DC 12V
Configuration	<input checked="" type="checkbox"/> Table-top <input type="checkbox"/> Floor-standing
Cable Supplied	USB

Note:

### 1. Other Accessory Device List and Details

Description	Manufacturer	Model	Note
USB	N/A	N/A	N/A

External I/O Cable

Cable Description	Shielded Type	Ferrite Core	Length(m)	Note
-	<input type="checkbox"/> Shielded <input type="checkbox"/> Non-shielded	<input type="checkbox"/> Yes <input type="checkbox"/> No		

2. The above EUT information is declared by manufacturer and for more detailed features description, please refer to the manufacturer's specifications or the User's Manual.

## 2. TEST SUMMARY

Test procedures according to the technical standards:

FCC Rules	Test Item	Test Result
§15.107	Conducted Emission	N/A
§15.109	Radiated Emission	PASS

Remark: N/A is abbreviation for Not Applicable.

The test was carried out in all the test modes, only the worst data are list in report.

### 3. FACILITIES

#### 3.1. Test Facility

##### CTB-LAB

Floor 1&2, Building A, No. 26 of Xinhe Road, Xinqiao Street, Baoan District, Shenzhen China

#### 3.2. Test Instruments

The following list contains measurement equipment used for testing. The equipment conforms to the requirement of CISPR 16-1, ANSI C63.2 and other required standards.

Calibration of all test and measurement, including any accessories that may effect such calibration, is checked frequently to ensure the accuracy. Adjustments are made and correction factors are applied in accordance with the instructions contained in the respective.

**Table list of the test and measurement equipment**

**Conducted Emission Measurement**

Item	Equipment	Manufacturer	Model No.	Serial No.	Calibrated until
1	AMN	R&S	ESH3-Z5	831551852	2021.10.30
2	Pulse limiter	R&S	ESH3Z2	357881052	2021.10.30
3	EMI test Receiver	R&S	ESCI	834115/006	2021.11.01
4	Coaxial cable	ZDECL	Z302S-BNCJ-BNCJ-1.5M	18091904	2021.10.30
5	CE Test software	FALA	EZ-EMC	Ver. EMC-con3A1 .1	N/A

**Radiated Emission Measurement**

Item	Equipment	Manufacturer	Model No.	Serial No.	Calibrated until
1	TRILOG Broadband Antenna	Schwarzbeck	VULB 9168	869	2021.11.02
2	Double Ridged Broadband Horn Antenna	Schwarzbeck	BBHA 9120 D	1911	2021.11.02
3	Preamplifier	Agilent	8449B	3008A01838	2021.11.01
4	Amplifier	HP	8447E	2945A02747	2021.11.01
5	Coaxial cable	ETS	RFC-SNS-100-NMS-80 NI	/	2021.11.01
6	Coaxial cable	ETS	RFC-SNS-100-NMS-20 NI	/	2021.11.01
7	Coaxial cable	ETS	RFC-SNS-100-SMS-20 NI	/	2021.11.01
8	Coaxial cable	ETS	RFC-NNS-100-NMS-300 NI	/	2021.11.01
9	EMI test Receiver	R&S	ESPI	100362	2021.11.01
10	MXA signal analyzer	Agilent	N9020A	MY52090073	2021.11.01
11	RE Test software	FALA	EZ-EMC	Ver. FA-03A2 RE	N/A

### 4. Measurement uncertainty

The following table is for the measurement uncertainty, which is calculated as per the document CISPR 16-4 and ANSI C63.4.

Test	Parameters	Expanded Uncertainty (U <sub>Lab</sub> )	Expanded Uncertainty (U <sub>Cispr</sub> )
Conducted Emission	Level Accuracy: 150kHz to 30MHz	±1.22 dB	±3.6 dB
Radiated Emission	Level Accuracy: 30MHz to 1000 MHz	±3.67 dB	±5.2 dB
Radiated Emission	Level Accuracy: Above 1000MHz	±4.79 dB	N/A

This uncertainty represents an expanded uncertainty expressed at approximately the 95% confidence level using a coverage factor of k=2.

#### 4.1. Operating condition of EUT

To investigate the maximum EMI emission characteristics generates from EUT, the test system was pre-scanning tested base on the consideration of following EUT operation mode or test configuration mode which possible have effect on EMI emission level. Each of these EUT operation mode(s) or test configuration mode(s) mentioned above was evaluated respectively

Pretest Mode	Description
Mode 1	Working

For Conducted Test	
Final Test Mode	Description
Mode 1	Working

For Radiated Test	
Final Test Mode	Description
Mode 1	Working
Mode 2	Charge

#### 4.2. Test conditions

- Temperature: 15-35°C
- Relative Humidity: 30-60 %
- Atmospheric pressure: 800hPa-1060hPa

#### 4.3. DESCRIPTION OF TEST SETUP

Working

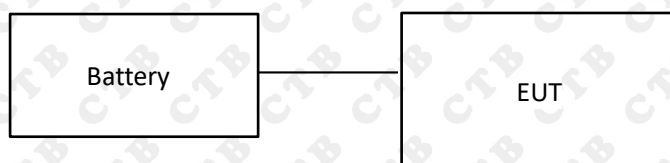

## 5. Conducted Emission

### 5.1.Limit

Except for Class B devices:

Frequency of emission (MHz)	Conducted limit (dB $\mu$ V)	
	Quasi-peak	Average
0.15-0.5	66 to 56*	56 to 46*
0.5-5	56	46
5-30	60	50

\*Decreases with the logarithm of the frequency.

For Class A devices:

Frequency of emission (MHz)	Conducted limit (dB $\mu$ V)	
	Quasi-peak	Average
0.15-0.5	79	66
0.5-30	73	60

### 5.2. Test setup

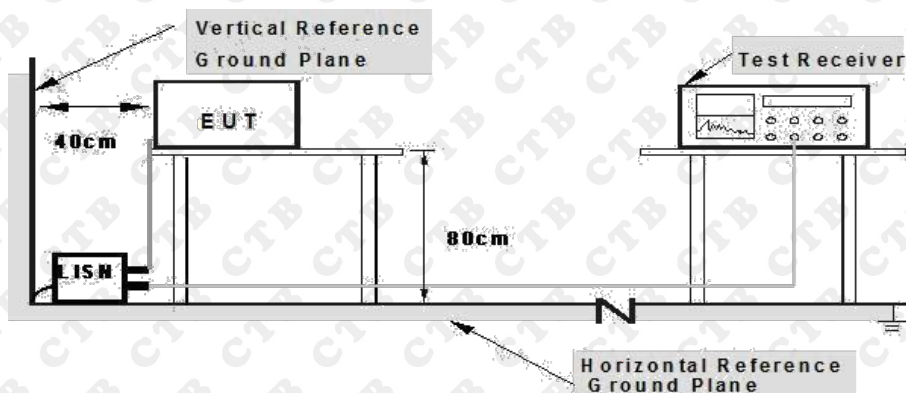

**Note: 1. Support units were connected to second LISN.  
2. Both of LISNs (AMN) are 80 cm from EUT and at least 80 from other units and other metal planes**

The setup of EUT is according with ANSI C63.4 measurement procedure. Specification used with FCC Part 15 limits.

### 5.3.EMI Test Receiver Setup

Frequency Range	9kHz-30MHz
Resolution Bandwidth	200Hz (9kHz-150kHz) 9kHz (150kHz-30MHz)



#### 5.4. Test procedure

Measurement was performed in shielded room, and instruments used were followed clause 4 of ANSI C63.4.

Detailed test procedure was following clause 7 of ANSI C63.4.

Frequency range 150kHz – 30MHz was checked and EMI receiver measurement bandwidth was set to 9 kHz.

#### 5.5. Test results

N/A

The EUT is powered by DC battery

## 6. Radiated emissions

### 6.1.Limit

Except for Class B devices (at 3m):

Frequency of emission (MHz)	Field strength (microvolts/meter)	
	(microvolts/meter)	(dB $\mu$ V/m)
30-88	100	40
88-216	150	43.5
216-960	200	46
Above 960	500	54

For Class A devices (at 10m):

Frequency of emission (MHz)	Field strength (microvolts/meter)	
	(microvolts/meter)	(dB $\mu$ V/m)
30-88	90	39
88-216	150	43.5
216-960	210	46.4
Above 960	300	49.5

### LIMITS OF RADIATED EMISSION MEASUREMENT

Frequency of emission (MHz)	Class A(dB $\mu$ V/m) (at 3M)		Class B(dB $\mu$ V/m) (at 3M)	
	PEAK	AVERAGE	PEAK	AVERAGE
Above 1000	80	60	74	54

### 6.2. Test setup

Radiated Emission Test Set-Up Frequency Below 1 GHz

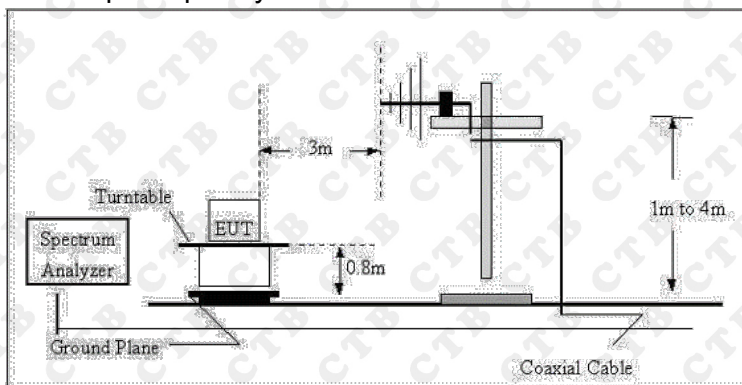

Radiated Emission Test Set-Up Frequency Above 1GHz

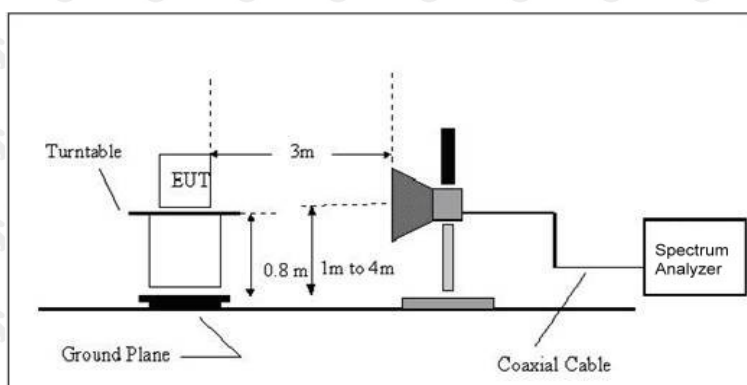

The radiated tests were performed in semi-anechoic(3m) test site, using the setup accordance with the ANSI C63.4:2014.

### EMI Test Receiver Setup and Spectrum Analyzer Setup

During the radiated emission test, the EMI test receiver and Spectrum Analyzer were set with the following configurations:

Frequency Range	RBW	Video B/W	IF B/W	Detector
30MHz-1000MHz	100kHz	300kHz	120kHz	QP
Above 1GHz	1MHz	3MHz	/	PK
	1MHz	10Hz	/	AVG

### 6.3. Test procedure

The measurement was performed in a semi-anechoic chamber, and instruments used were followed clause 4 of ANSI C63.4.

Detailed test procedure was following clause 8 of ANSI C63.4.

Note: for the measurement distance other than 3m and 10m, the limit is varied according to 20dB /10 decades.

### 6.4. Corrected Amplitude & Margin Calculation

The Corrected Amplitude is calculated by adding the Antenna Factor and Cable Loss, and subtracting the Amplifier Gain from the Meter Reading. The basic equation is as follows:

$$\text{Corrected Amplitude} = \text{Meter Reading} + \text{Antenna Factor} + \text{Cable Loss} - \text{Amplifier Gain}$$

The "Margin" column of the following data tables indicates the degree of compliance with the applicable limit. For example, a margin of 7dB means the emission is 7dB below the limit. The equation for margin calculation is as follows:

$$\text{Margin} = \text{Limit} - \text{Corrected Amplitude}$$

### 6.5. Test results

**PASS**

Please refer to the following page.

Polarization: H

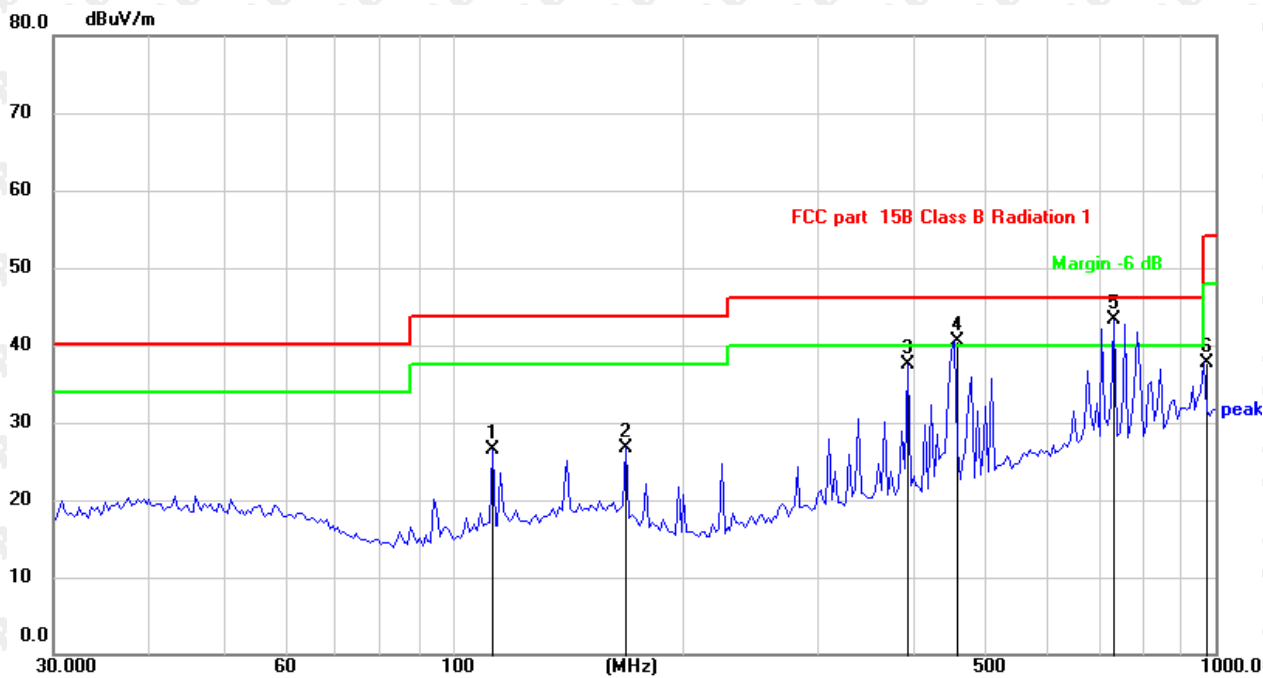

No.	Mk.	Freq. MHz	Reading Level dBuV	Correct Factor dB	Measure- ment dBuV/m	Limit dB/m	Over dB	Detector
1		112.7218	36.07	-9.55	26.52	43.50	-16.98	QP
2		168.7093	35.09	-8.29	26.80	43.50	-16.70	QP
3		394.8545	42.89	-5.41	37.48	46.00	-8.52	QP
4	!	454.3100	44.55	-4.11	40.44	46.00	-5.56	QP
5	*	735.7802	41.74	1.63	43.37	46.00	-2.63	QP
6		965.5421	33.34	4.39	37.73	54.00	-16.27	QP

Note: Result=Reading+Factor  
Over Limit=Result-Limit

Polarization: V

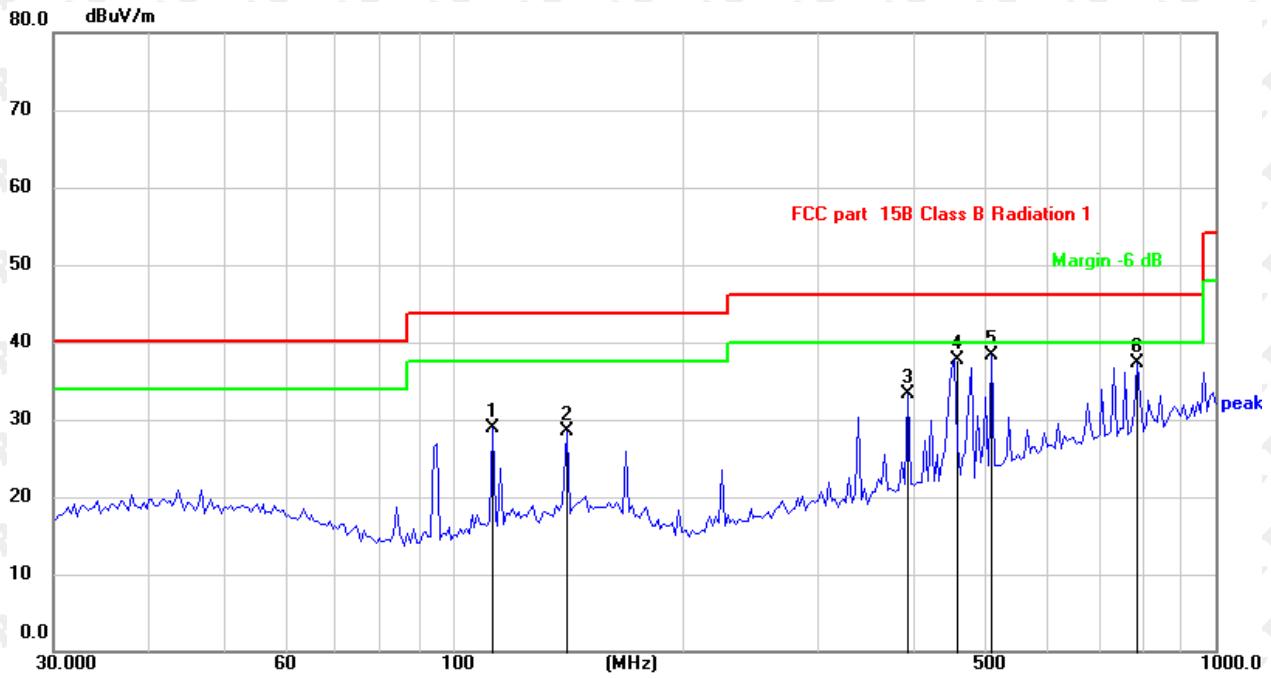

No.	Mk.	Freq. MHz	Reading Level dBuV	Correct Factor dB	Measure- ment dBuV/m	Limit dB/m	Over dB	Detector
1		112.7218	38.54	-9.55	28.99	43.50	-14.51	QP
2		141.5777	36.16	-7.69	28.47	43.50	-15.03	QP
3		394.8545	38.81	-5.41	33.40	46.00	-12.60	QP
4		454.3100	41.83	-4.11	37.72	46.00	-8.28	QP
5	*	509.1501	41.19	-2.83	38.36	46.00	-7.64	QP
6		789.2338	35.30	2.10	37.40	46.00	-8.60	QP

Note: Result=Reading+Factor  
Over Limit=Result-Limit

Above 1 G

Polarization: H

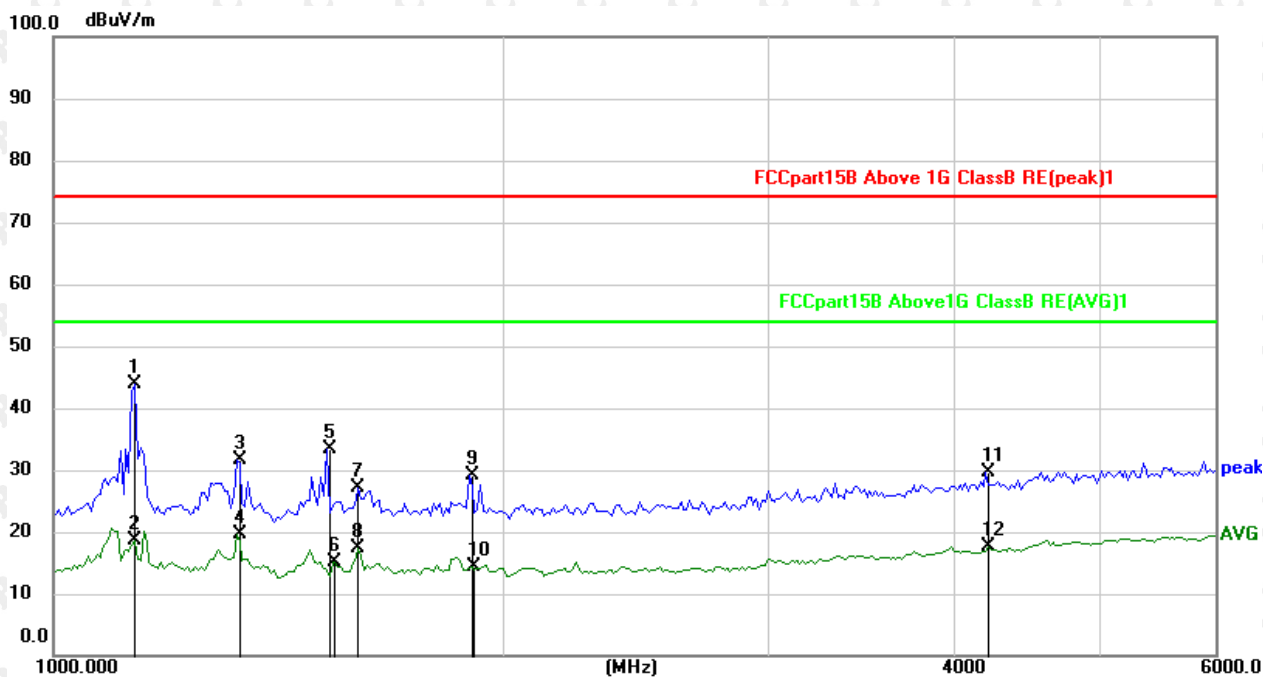

No.	Mk.	Freq. MHz	Reading Level dBuV	Correct Factor dB	Measure- ment dBuV/m	Limit dB/m	Over dB	Detector
1	*	1133.628	54.15	-10.18	43.97	74.00	-30.03	peak
2		1133.628	28.75	-10.18	18.57	54.00	-35.43	AVG
3		1326.047	41.20	-9.55	31.65	74.00	-42.35	peak
4		1326.047	29.16	-9.55	19.61	54.00	-34.39	AVG
5		1523.581	42.30	-8.93	33.37	74.00	-40.63	peak
6		1537.292	24.08	-8.88	15.20	54.00	-38.80	AVG
7		1600.533	35.80	-8.68	27.12	74.00	-46.88	peak
8		1600.533	26.09	-8.68	17.41	54.00	-36.59	AVG
9		1897.532	36.85	-7.73	29.12	74.00	-44.88	peak
10		1906.051	21.97	-7.70	14.27	54.00	-39.73	AVG
11		4211.787	31.63	-2.05	29.58	74.00	-44.42	peak
12		4230.695	19.57	-2.00	17.57	54.00	-36.43	AVG

Note: Result=Reading+Factor  
Over Limit=Result-Limit

Polarization: V

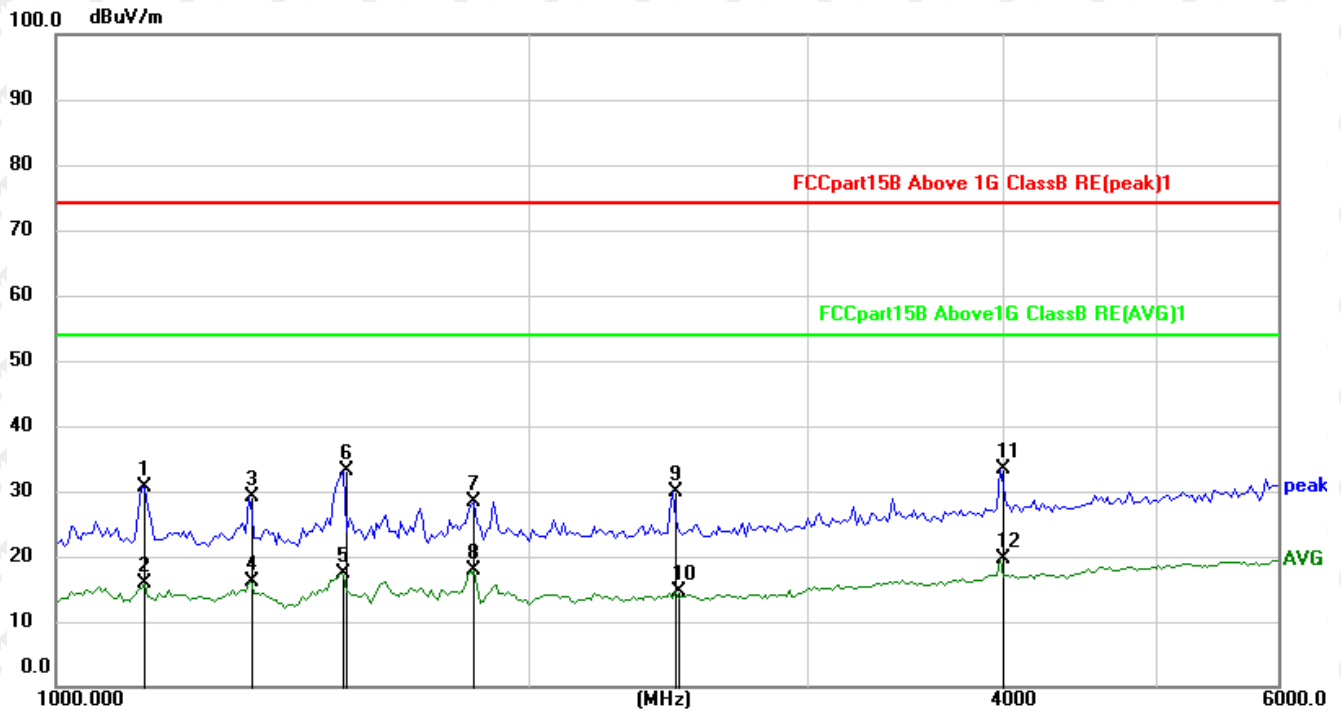

No.	Mk.	Freq. MHz	Reading Level dBuV	Correct Factor dB	Measure- ment dBuV/m	Limit dB/m	Over dB	Detector
1		1138.717	40.74	-10.15	30.59	74.00	-43.41	peak
2		1138.717	25.94	-10.15	15.79	54.00	-38.21	AVG
3		1326.047	38.67	-9.55	29.12	74.00	-44.88	peak
4		1326.047	25.69	-9.55	16.14	54.00	-37.86	AVG
5		1516.772	26.40	-8.94	17.46	54.00	-36.54	AVG
6		1523.581	42.05	-8.93	33.12	74.00	-40.88	peak
7		1847.212	36.34	-7.89	28.45	74.00	-45.55	peak
8		1847.212	25.79	-7.89	17.90	54.00	-36.10	AVG
9		2471.533	35.83	-5.94	29.89	74.00	-44.11	peak
10		2482.629	20.54	-5.90	14.64	54.00	-39.36	AVG
11		3991.369	35.91	-2.63	33.28	74.00	-40.72	peak
12	*	3991.369	22.32	-2.63	19.69	54.00	-34.31	AVG

Note: Result=Reading+Factor  
Over Limit=Result-Limit

## 7. Photographs of test setup

Photograph of test setup for Radiated disturbance



Photograph of test setup for Radiated disturbance





### 8. Photographs of EUT



Photographs of EUT

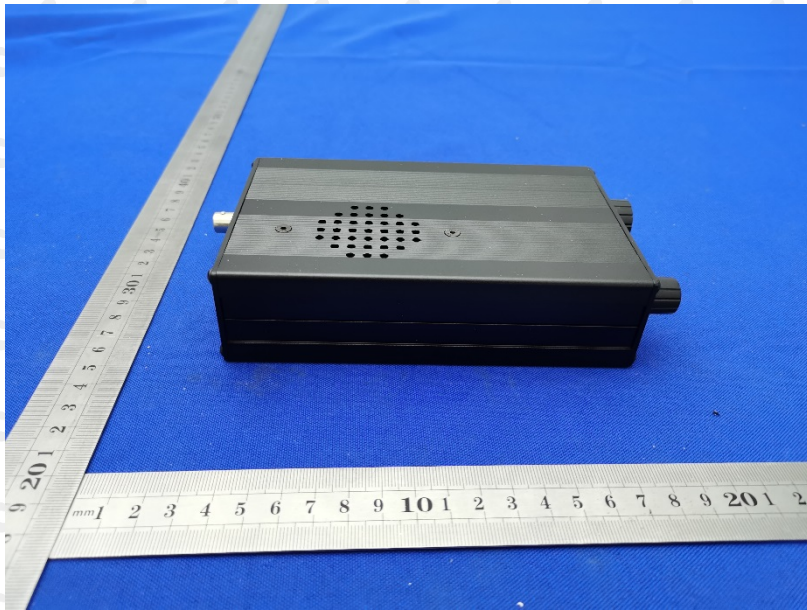

Photographs of EUT

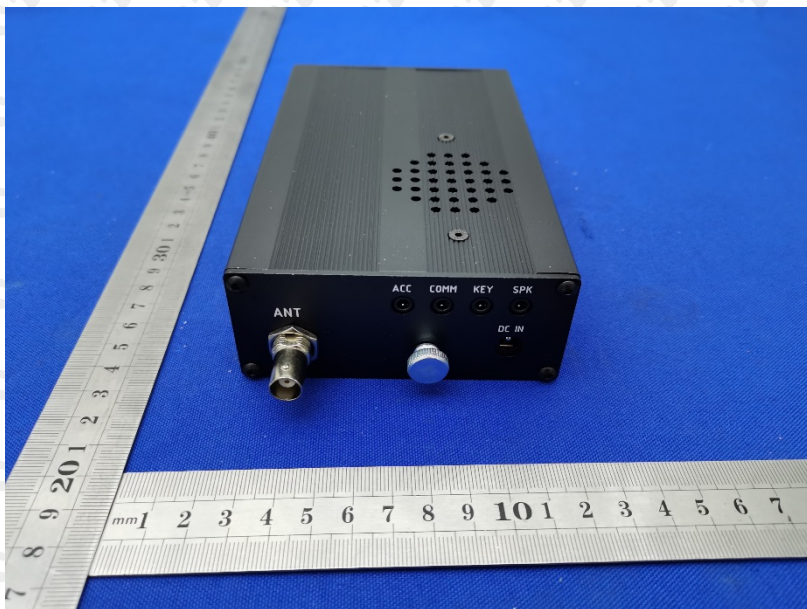

\*\*\*End of report\*\*\*