

7)

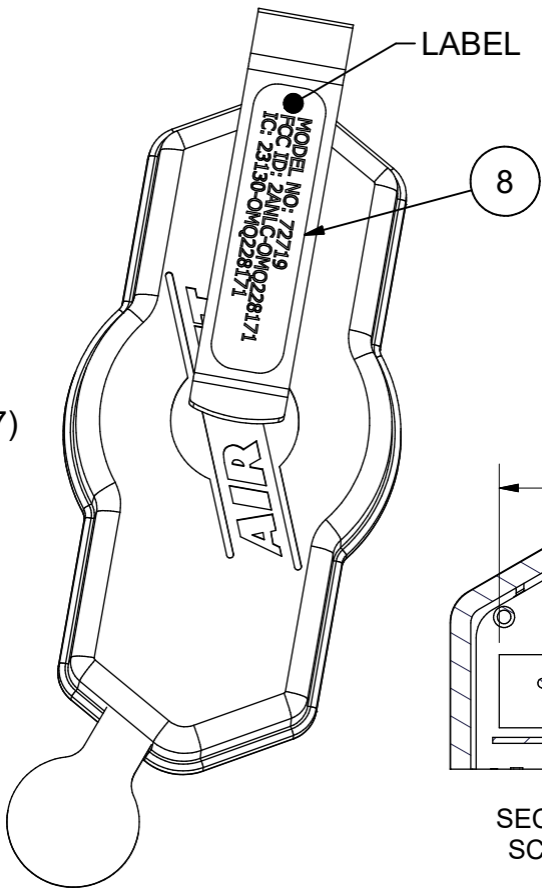

LABEL

8

SEC
SCA