

Amber Helm Development L.C.

92723 Michigan Hwy-152

Sister Lakes, Michigan 49047 USA

Tel: 888-847-8027

EMC Test Report

AIRL-WR1910TX

Issued: July 1, 2019

regarding

USA: CFR Title 47, Part 15.247 (Emissions)
Canada: ISED RSS-247v2/GENv5 (Emissions)

for



72719

Category: DTS Transceiver

Judgments:

15.247/RSS-247v2 Transceiver

Testing Completed: June 10, 2019



Prepared for:

Air Lift Company

2727 Snow Road, Lansing Michigan 48917 USA

Phone: (517) 322-2144, Fax: (517) 322-9479

Contact: Julian Quick, jquick@airliftcompany.com

Data Recorded by:

Joseph Brunett
Dr. Joseph Brunett, EMC-002790-NE

Reviewed by:

Gordon L. Helm
Gordon Helm, EMC-002401-NE

Prepared by:

Joseph Brunett
Dr. Joseph Brunett, EMC-002790-NE

Date of Issue: July 1, 2019

Revision History

| Rev. No. | Date | Details | Revised By |
|----------|---------------|-------------------|------------|
| r0 | July 1, 2019 | Initial Release. | J. Brunett |
| r1 | July 15, 2019 | Typo Corrections. | J. Brunett |

Contents

| | |
|---|-----------|
| Revision History | 2 |
| Table of Contents | 2 |
| 1 Test Report Scope and Limitations | 5 |
| 1.1 Laboratory Authorization | 5 |
| 1.2 Report Retention | 5 |
| 1.3 Subcontracted Testing | 5 |
| 1.4 Test Data | 5 |
| 1.5 Limitation of Results | 5 |
| 1.6 Copyright | 5 |
| 1.7 Endorsements | 5 |
| 1.8 Test Location | 6 |
| 1.9 Traceability and Equipment Used | 6 |
| 2 Test Specifications and Procedures | 7 |
| 2.1 Test Specification and General Procedures | 7 |
| 3 Configuration and Identification of the Equipment Under Test | 8 |
| 3.1 Description and Declarations | 8 |
| 3.1.1 EUT Configuration | 9 |
| 3.1.2 Modes of Operation | 9 |
| 3.1.3 Variants | 9 |
| 3.1.4 Test Samples | 9 |
| 3.1.5 Functional Exerciser | 9 |
| 3.1.6 Modifications Made | 9 |
| 3.1.7 Production Intent | 9 |
| 3.1.8 Declared Exemptions and Additional Product Notes | 9 |
| 4 Emissions | 10 |
| 4.1 General Test Procedures | 10 |
| 4.1.1 Radiated Test Setup and Procedures | 10 |
| 4.1.2 Conducted Emissions Test Setup and Procedures | 12 |
| 4.1.3 Power Supply Variation | 12 |
| 4.2 Intentional Emissions | 13 |
| 4.2.1 Duty and Transmission Cycle, Pulsed Operation | 13 |
| 4.2.2 Fundamental Emission Bandwidth | 14 |
| 4.2.3 Effective Isotropic Radiated Power | 16 |
| 4.2.4 Power Spectral Density | 17 |
| 4.3 Unintentional Emissions | 19 |
| 4.3.1 Transmit Chain Spurious Emissions | 19 |
| 4.3.2 Relative Transmit Chain Spurious Emissions | 20 |
| 4.3.3 Radiated Digital Spurious | 21 |

5 Measurement Uncertainty and Accreditation Documents

22

List of Tables

| | | |
|---|---|----|
| 1 | Test Site List. | 6 |
| 2 | Equipment List. | 6 |
| 3 | EUT Declarations. | 8 |
| 4 | Pulsed Emission Characteristics (Duty Cycle). | 13 |
| 5 | Intentional Emission Bandwidth. | 14 |
| 6 | Radiated Power Results. | 16 |
| 7 | Power Spectral Density Results. | 17 |
| 8 | Transmit Chain Spurious Emissions. | 19 |
| 9 | Measurement Uncertainty. | 22 |

List of Figures

| | | |
|----|---|----|
| 1 | Photos of EUT. | 8 |
| 2 | EUT Test Configuration Diagram. | 9 |
| 3 | Radiated Emissions Diagram of the EUT. | 10 |
| 4 | Radiated Emissions Test Setup Photograph(s). | 11 |
| 5 | Conducted RF Test Setup Photograph(s). | 12 |
| 6 | Pulsed Emission Characteristics (Duty Cycle). | 13 |
| 7 | Intentional Emission Bandwidth. | 15 |
| 8 | Conducted RF Power Plots | 16 |
| 9 | Power Spectral Density Plots. | 18 |
| 10 | Conducted Transmitter Emissions Measured. | 20 |
| 11 | Accreditation Documents | 22 |

1 Test Report Scope and Limitations

1.1 Laboratory Authorization

Test Facility description and attenuation characteristics are on file with the FCC Laboratory, Columbia, Maryland (FCC Reg. No: US5348 and US5356) and with ISED Canada, Ottawa, ON (File Ref. No: US0213). Amber Helm Development L.C. holds accreditation under NVLAP Lab Code 200129-0.

1.2 Report Retention

For equipment verified to comply with the regulations herein, the manufacturer is obliged to retain this report with the product records for the life of the product, and no less than ten years. A copy of this Report will remain on file with this laboratory until Aug 2029.

1.3 Subcontracted Testing

This report does not contain data produced under subcontract.

1.4 Test Data

This test report contains data included within the laboratories scope of accreditation.

1.5 Limitation of Results

The test results contained in this report relate only to the item(s) tested. Any electrical or mechanical modification made to the test item subsequent to the test date shall invalidate the data presented in this report. Any electrical or mechanical modification made to the test item subsequent to this test date shall require reevaluation.

1.6 Copyright

This report shall not be reproduced, except in full, without the written approval of Amber Helm Development L.C.

1.7 Endorsements

This report shall not be used to claim product endorsement by any accrediting, regulatory, or governmental agency.

1.8 Test Location

The EUT was fully tested by **Amber Helm Development L.C.**, headquartered at 92723 Michigan Hwy-152, Sister Lakes, Michigan 49047 USA. Table 1 lists all sites employed herein. Specific test sites utilized are also listed in the test results sections of this report where needed.

Table 1: Test Site List.

| Description | Location | Quality Num. |
|----------------|---|--------------|
| OATS (3 meter) | 3615 E Grand River Rd., Williamston, Michigan 48895 | OATSC |

1.9 Traceability and Equipment Used

Pertinent test equipment used for measurements at this facility is listed in Table 2. The quality system employed at Amber Helm Development L.C. has been established to ensure all equipment has a clearly identifiable classification, calibration expiry date, and that all calibrations are traceable to the SI through NIST, other recognized national laboratories, accepted fundamental or natural physical constants, ratio type of calibration, or by comparison to consensus standards.

Table 2: Equipment List.

| Description | Manufacturer/Model | SN | Quality Num. | Last Cal By / Date Due |
|----------------------|-------------------------|-----------|--------------|------------------------|
| Spectrum Analyzer | Rohde & Schwarz / FSV30 | 101660 | RSFSV30001 | RS / Apr-2021 |
| Biconical | EMCO / 93110B | 9802-3039 | BICEMCO01 | Keysight / Aug-2019 |
| Log Periodic Antenna | EMCO / 3146 | 9305-3614 | LOGEMCO01 | Keysight / Aug-2019 |
| BNC-BNC Coax | WRTL / RG58/U | 001 | CAB001-BLACK | AHD / Jul-2019 |
| BNC-BNC Coax | WRTL / RG58/U | 001 | CAB002-BLACK | AHD / Jul-2019 |
| 3.5-3.5MM Coax | PhaseFlex / PhaseFlex | 001 | CAB015-PURP | AHD / Jul-2019 |
| Quad Ridge Horn | Singer / A6100 | C35200 | HQR1TO18S01 | Keysight / Aug-2019 |
| K-Band Horn | JEF / NRL Std. | 001 | HRNK01 | AHD / Jul-2019 |

2 Test Specifications and Procedures

2.1 Test Specification and General Procedures

The ultimate goal of Air Lift Company is to demonstrate that the Equipment Under Test (EUT) complies with the Rules and/or Directives below. Detailed in this report are the results of testing the Air Lift Company 72719 for compliance to:

| Country/Region | Rules or Directive | Referenced Section(s) |
|----------------|-----------------------------|---------------------------|
| United States | Code of Federal Regulations | CFR Title 47, Part 15.247 |
| Canada | ISED Canada | ISED RSS-247v2/GENv5 |

It has been determined that the equipment under test is subject to the rules and directives above at the date of this testing. In conjunction with these rules and directives, the following specifications and procedures are followed herein to demonstrate compliance (in whole or in part) with these regulations.

| | |
|--------------------------|---|
| ANSI C63.4:2014 | "Methods of Measurement of Radio-Noise Emissions from Low-Voltage Electrical and Electronic Equipment in the Range of 9 kHz to 40 GHz" |
| ANSI C63.10:2013 | "American National Standard of Procedures for Compliance Testing of Unlicensed Wireless Devices" |
| KDB 558074 D01 v05r02 | "GUIDANCE FOR COMPLIANCE MEASUREMENTS ON DIGITAL TRANSMISSION SYSTEM, FREQUENCY HOPPING SPREAD SPECTRUM SYSTEM, AND HYBRID SYSTEM DEVICES OPERATING UNDER SECTION 15.247 OF THE FCC RULES " |
| TP0102RA | "AHD Internal Document TP0102 - Radiated Emissions Test Procedure" |
| ISED Canada | "The Measurement of Occupied Bandwidth" |
| ICES-003; Issue 6 (2016) | "Information Technology Equipment (ITE) Limits and methods of measurement" |

3 Configuration and Identification of the Equipment Under Test

3.1 Description and Declarations

The EUT is a remote control for an electronic suspension control system. The EUT is approximately 11 x 4 x 3 cm in dimension, and is depicted in Figure 1. It is powered by 6 VDC Lithium Coin-cell batteries. The EUT is a remote with integrated LCD and buttons used to control and gain feedback from a separate electronic suspension device. Table 3 outlines provider declared EUT specifications.



Figure 1: Photos of EUT.

Table 3: EUT Declarations.

| General Declarations | |
|----------------------|-----------------|
| Equipment Type: | DTS Transceiver |
| Country of Origin: | USA |
| Nominal Supply: | 6 VDC |
| Oper. Temp Range: | Not Declared |
| Frequency Range: | 2402 – 2480 MHz |
| Antenna Dimension: | Not Declared |
| Antenna Type: | PCB Trace |
| Antenna Gain: | Not Declared |
| Number of Channels: | 40 |
| Channel Spacing: | Not Declared |
| Alignment Range: | Not Declared |
| Type of Modulation: | GFSK |
| United States | |
| FCC ID Number: | 2ANLC-OMQ228171 |
| Classification: | DTS |
| Canada | |
| IC Number: | 23130-OMQ228171 |
| Classification: | Spread Spectrum |

3.1.1 EUT Configuration

The EUT is configured for testing as depicted in Figure 2.



Figure 2: EUT Test Configuration Diagram.

3.1.2 Modes of Operation

The EUT is capable of GFSK modulation as tested herein.

3.1.3 Variants

There is only a single variant of the EUT, as tested.

3.1.4 Test Samples

Two samples in total were provided, both with software modified for continuous transmission on the Low, Middle, and High channels.

3.1.5 Functional Exerciser

Normal operating EUT functionality was verified by observation of transmitted signal.

3.1.6 Modifications Made

There were no modifications made to the EUT by this laboratory.

3.1.7 Production Intent

The EUT appears to be a production ready sample.

3.1.8 Declared Exemptions and Additional Product Notes

None.

4 Emissions

4.1 General Test Procedures

4.1.1 Radiated Test Setup and Procedures

Radiated electromagnetic emissions from the EUT are first pre-scanned in our screen room. Spectrum and modulation characteristics of all emissions are recorded. Instrumentation, including spectrum analyzers and other test equipment as detailed in Section 1.8 are employed. After pre-scan, emission measurements are made on the test site of record. If the EUT connects to auxiliary equipment and is table or floor standing, the configurations prescribed in relevant test standards are followed. Alternatively, a layout closest to normal use (as declared by the provider) is employed if the resulting emissions appear to be worst-case in such a configuration. See Figure 3. All intentionally radiating elements that are not fixed-mounted in use are placed on the test table lying flat, on their side, and on their end (3-axes) and the resulting worst case emissions are recorded. If the EUT is fixed-mounted in use, measurements are made with the device oriented in the manner consistent with installation and then emissions are recorded. If the EUT exhibits spurious emissions due to internal receiver circuitry, such emissions are measured with an appropriate carrier signal applied.

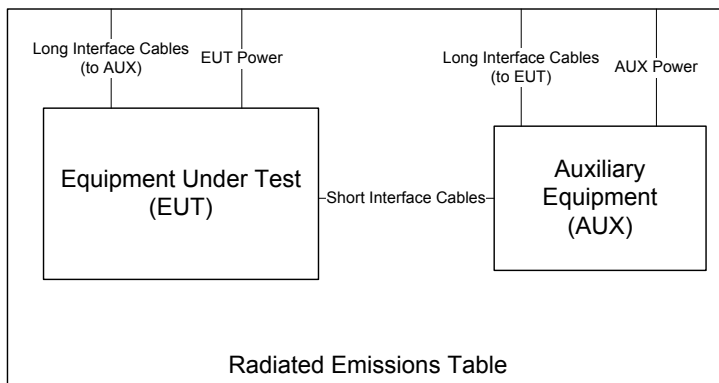

Figure 3: Radiated Emissions Diagram of the EUT.

For devices with intentional emissions below 30 MHz, a shielded loop antenna and/or E-field and H-Field broadband probes are used depending on the regulations. Shielded loops are placed at a 1 meter receive height at the desired measurement distance. For exposure in this band, the broadband probes employed are 10cm diameter single-axis shielded transducers and measurements are repeated and summed over three axes.

Emissions between 30 MHz and 1 GHz are measured using calibrated broadband antennas. For both horizontal and vertical polarizations, the test antenna is raised and lowered from 1 to 4 m in height until a maximum emission level is detected. The EUT is then rotated through 360° in azimuth until the highest emission is detected. The test antenna is then raised and lowered one last time from 1 to 4 m and the worst case value is recorded. Emissions above 1 GHz are characterized using standard gain or broadband ridge-horn antennas on our OATS with a 4×5 m rectangle of ECCOSORB absorber covering the OATS ground screen and a 1.5m table height. Care is taken to ensure that test receiver resolution and video bandwidths meet the regulatory requirements, and that the emission bandwidth of the EUT is not reduced. Photographs of the test setup employed are depicted in Figure 4.

Where regulations allow for direct measurement of field strength, power values (dBm) measured on the test receiver / analyzer are converted to $\text{dB}\mu\text{V}/\text{m}$ at the regulatory distance, using

$$E_{dist} = 107 + P_R + K_A - K_G + K_E - C_F$$

where P_R is the power recorded on spectrum analyzer, in dBm, K_A is the test antenna factor in dB/m, K_G is the combined pre-amplifier gain and cable loss in dB, K_E is duty correction factor (when applicable) in dB, and C_F is a distance conversion (employed only if limits are specified at alternate distance) in dB. This field strength value is then compared with the regulatory limit. If effective isotropic radiated power (EIRP) is computed, it is computed as

$$EIRP(\text{dBm}) = E_{3m}(\text{dB}\mu\text{V}/\text{m}) - 95.2.$$

When presenting data at each frequency, the highest measured emission under all possible EUT orientations (3-axes) is reported.



Figure 4: Radiated Emissions Test Setup Photograph(s).

4.1.2 Conducted Emissions Test Setup and Procedures

Transmit Antenna Port Conducted Emissions At least one sample EUT supplied for testing was provided with a 50Ω antenna port. Conducted transmit chain emissions measurements (where applicable) are made by connecting the EUT antenna port directly to the test receiver port. Photographs of the test setup employed are depicted in Figure 5.



Figure 5: Conducted RF Test Setup Photograph(s).

The EUT is not subject to measurement of power line conducted emissions as it is powered solely by its internal battery.

4.1.3 Power Supply Variation

Tests at extreme supply voltages are made if required by the procedures specified in the test standard, and results of this testing are detailed in this report.

In the case the EUT is designed for operation from a battery power source, the extreme test voltages are evaluated over the range specified in the test standard; no less than $\pm 10\%$ of the nominal battery voltage declared by the manufacturer. For all battery operated equipment, worst case intentional and spurious emissions are re-checked employing a new (fully charged) battery.

4.2 Intentional Emissions

4.2.1 Duty and Transmission Cycle, Pulsed Operation

The details and results of testing the EUT for pulsed operation are summarized in Table 4. Plots showing the measurements made to obtain these values are provided in Figure 6.

Table 4: Pulsed Emission Characteristics (Duty Cycle).

| | | | | |
|---|------------------|----------------------|----------------------|---|
| Frequency Range f > 1 000 MHz | Det Pk | IFBW 3 MHz | VBW 10 MHz | Test Date: 11-Jun-19 |
| | | | | Test Engineer: Joseph Brunett |
| | | | | EUT Airlift RMT |
| | | | | Meas. Distance: Conducted |

| Pulsed Operation / Duty Cycle | | | | | | | | |
|-------------------------------|----------------------|------------------|-------------|------------------|---------------------|---------------|----------------|----------------------------|
| Transmit Mode | Symbol Rate (Msym/s) | Data Rate (Mbps) | Voltage (V) | Oper. Freq (MHz) | Tx Cycle Time* (ms) | On-Time* (ms) | Duty Cycle (%) | Power Duty Correction (dB) |
| GFSK | 1.000 | GFSK (1 Mbps) | 13.4 | 2440.0 | - | - | 100.0 | 0.0 |



Figure 6: Pulsed Emission Characteristics (Duty Cycle).

4.2.2 Fundamental Emission Bandwidth

Emission bandwidth (EBW) of the EUT is measured with the device placed in the test mode(s) with the shortest available packet length and minimum packet spacing. Radiated emissions are recorded following the test procedures listed in Section 2.1. The 6 dB bandwidth is measured for the lowest, middle, and highest channels available. The 99% emission bandwidth per IC test procedures is also reported. The results of this testing are summarized in Table 5. Plots showing measurements employed obtain the emission bandwidths reported are provided in Figure 7.

Table 5: Intentional Emission Bandwidth.

| | | | | | |
|------------------------|------------|-------------|------------|------------------------|----------------|
| Frequency Range | Det | IFBW | VBW | Test Date: | 06/11/19 |
| f > 1 000 MHz | Pk | 30 kHz | 100 kHz | Test Engineer: | Joseph Brunett |
| f > 1 000 MHz | Pk | 30 kHz | 100 kHz | EUT | Airlift RMT |
| | | | | Meas. Distance: | Cond. |

| Occupied Bandwidth | | | | | | | | | |
|--------------------|----------------------|-------------------|-------------|------------------|---------------|---------------------|---------------|----------------|-----------|
| Transmit Mode | Symbol Rate (Msym/s) | Data Rate* (Mbps) | Voltage (V) | Oper. Freq (MHz) | 6 dB BW (MHz) | 6 dB BW Limit (MHz) | 99% OBW (MHz) | 20 dB BW (MHz) | Pass/Fail |
| GFSK | - | - | 6.0 | 2402.0 | 0.725 | - | 1.076 | 1.268 | Pass |
| | | | | 2440.0 | 0.689 | - | 1.079 | 1.247 | Pass |
| | | | | 2480.0 | 0.695 | - | 1.079 | 1.256 | Pass |

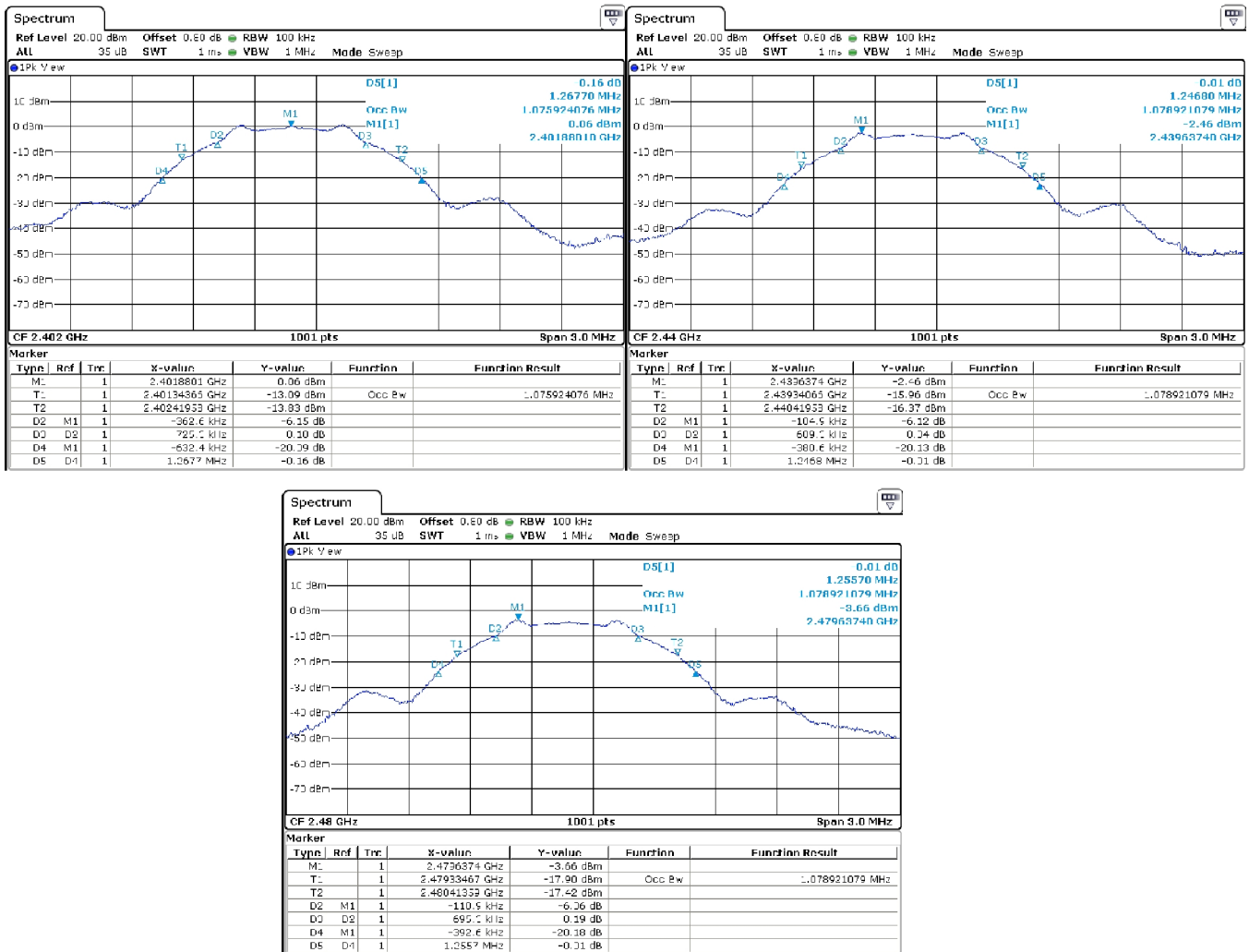

Figure 7: Intentional Emission Bandwidth.

4.2.3 Effective Isotropic Radiated Power

The EUT's radiated power is computed from antenna port conducted power measurements and the gain of the EUT antenna(s). Where the EUT is not sold with an antenna connector, a modified product has been provided including such. Peak conducted output power was measured directly from the EUT at the port where the antenna attaches. The test receiver bandwidth was set to be greater than the measured emission bandwidth of the EUT to capture the true peak. Antenna gain is either provided directly by the antenna manufacturer or measured by comparison between calculated EIRP and conducted output power. Table 6 details the results of these measurements. Plots showing conducted measurements made are depicted in Figure 8.

Table 6: Radiated Power Results.

| | | | | | |
|------------------------|------------|---------------------|------------------------|------------------------|-------------|
| Frequency Range | Det | IF Bandwidth | Video Bandwidth | Test Date: | 26-Feb-19 |
| 25 MHz f 1 000 MHz | Pk/QPk | 120 kHz | 300 kHz | Test Engineer: | J. Brunett |
| f > 1 000 MHz | Pk/Avg | 3 MHz | 3 MHz | EUT: | Airlift RMT |
| | | | | Meas. Distance: | 3m |

| | | | | | | | | | | | | | | | FCC/IC |
|---|------|---------|-----------|----------------|-----------|-----------------|--------------|-----------|---------|----------------------|---------------|----------------|--------------|----------------------|---------|
| # | Mode | Channel | Freq. MHz | Ant. Used | Ant. Pol. | Table Azim. deg | Ant Height m | Ka (dB/m) | Kg (dB) | Efield @ 3m (dBuV/m) | EIRP (Pk) dBm | Pout* (Pk) dBm | Ant Gain dBi | EIRP (Avg) Limit dBm | Pass dB |
| 1 | GFSK | L | 2402.0 | HQR2TO18S01 | H/V | 270.0 | 1.5 | 30.5 | -0.3 | 95.3 | .1 | .1 | 0.0 | 30.0 | 29.9 |
| 2 | | M | 2440.0 | HQR2TO18S01 | H/V | 270.0 | 1.5 | 30.7 | -0.3 | 94.4 | -8 | -3.1 | 2.3 | 30.0 | 30.8 |
| 3 | | H | 2480.0 | HQR2TO18S01 | H/V | 270.0 | 1.5 | 30.8 | -0.3 | 92.2 | -3.0 | -4.4 | 1.4 | 30.0 | 33.0 |
| 4 | | | | | | | | | | | | | | | |
| # | Mode | Channel | Freq. MHz | Supply Voltage | Ant. Pol. | Table Azim. deg | Ant Height m | Ka dB/m | Kg dB | E3(Pk) dBuV/m | | | | | |
| 5 | GFSK | L | 2440.0 | 5.4 | H/V | 270.0 | 1.5 | 30.7 | -0.3 | 94.5 | | | | | |
| 6 | | | 2440.0 | 6.0 | H/V | 270.0 | 1.5 | 30.7 | -0.3 | 94.4 | | | | | |
| 7 | | | 2440.0 | 6.6 | H/V | 270.0 | 1.5 | 30.7 | -0.3 | 94.4 | | | | | |

* Measured conducted out of modified sample.
 ** Measured radiated at 3 meter distance. Peak power measured with IFBW > OBW

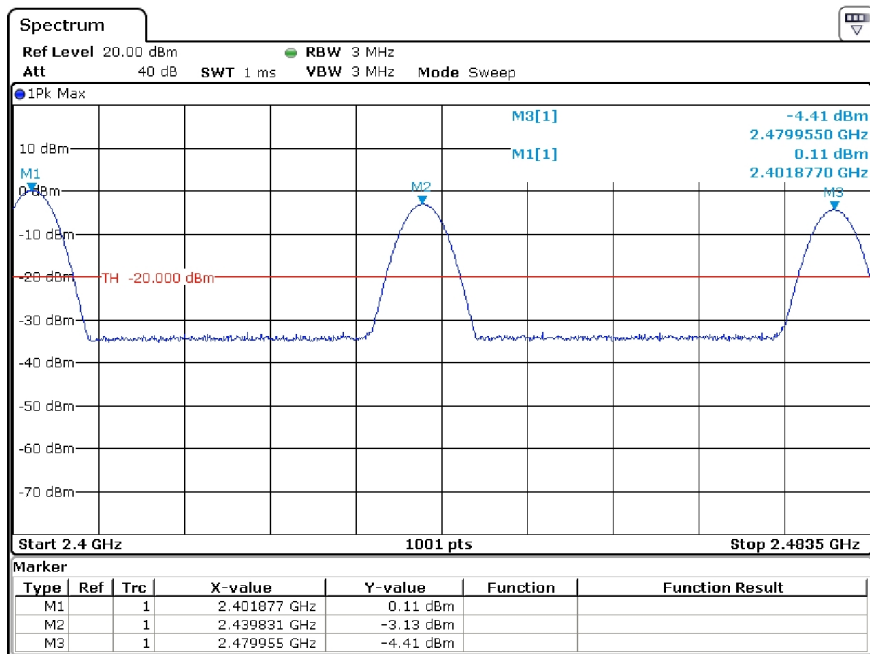

Figure 8: Conducted RF Power Plots

4.2.4 Power Spectral Density

For this test, the EUT was attached directly to the test receiver. Following FCC DTS measurement procedures, the emission spectrum is first scanned for maximum spectral peaks, the span and receiver bandwidth are then reduced until the power spectral density is measured in the prescribed receiver bandwidth. The results of this testing are summarized in Table 7. Plots showing how these measurements were made are depicted in Figure 9.

Table 7: Power Spectral Density Results.

| | | | | |
|---------------------------------------|-----------------------|------------------------------|----------------------------------|---|
| Frequency Range 2400-2483.5 | Detector Pk | IF Bandwidth 3 kHz | Video Bandwidth 10 kHz | Test Date: 5-Jun-19 |
| | | | | Test Engineer: Joseph Brunett |
| | | | | EUT: Airlift RMT |
| | | | | Meas. Distance: Conducted |

| FCC/IC | | | | | | |
|--------|---------|-----------------|-----------|----------------------------|----------------------|--------------|
| Mode | Channel | Frequency (MHz) | Ant. Used | PSDcond (meas)* (dBm/3kHz) | PSD Limit (dBm/3kHz) | Pass By (dB) |
| CM | L | 2402.0 | Cond. | -14.4 | 8.00 | 22.4 |
| | M | 2440.0 | Cond. | -15.5 | 8.00 | 23.5 |
| | H | 2480.0 | Cond. | -16.4 | 8.00 | 24.4 |

* PSD measured conducted out the EUT antenna port following FCC DTS PKPSD procedure.

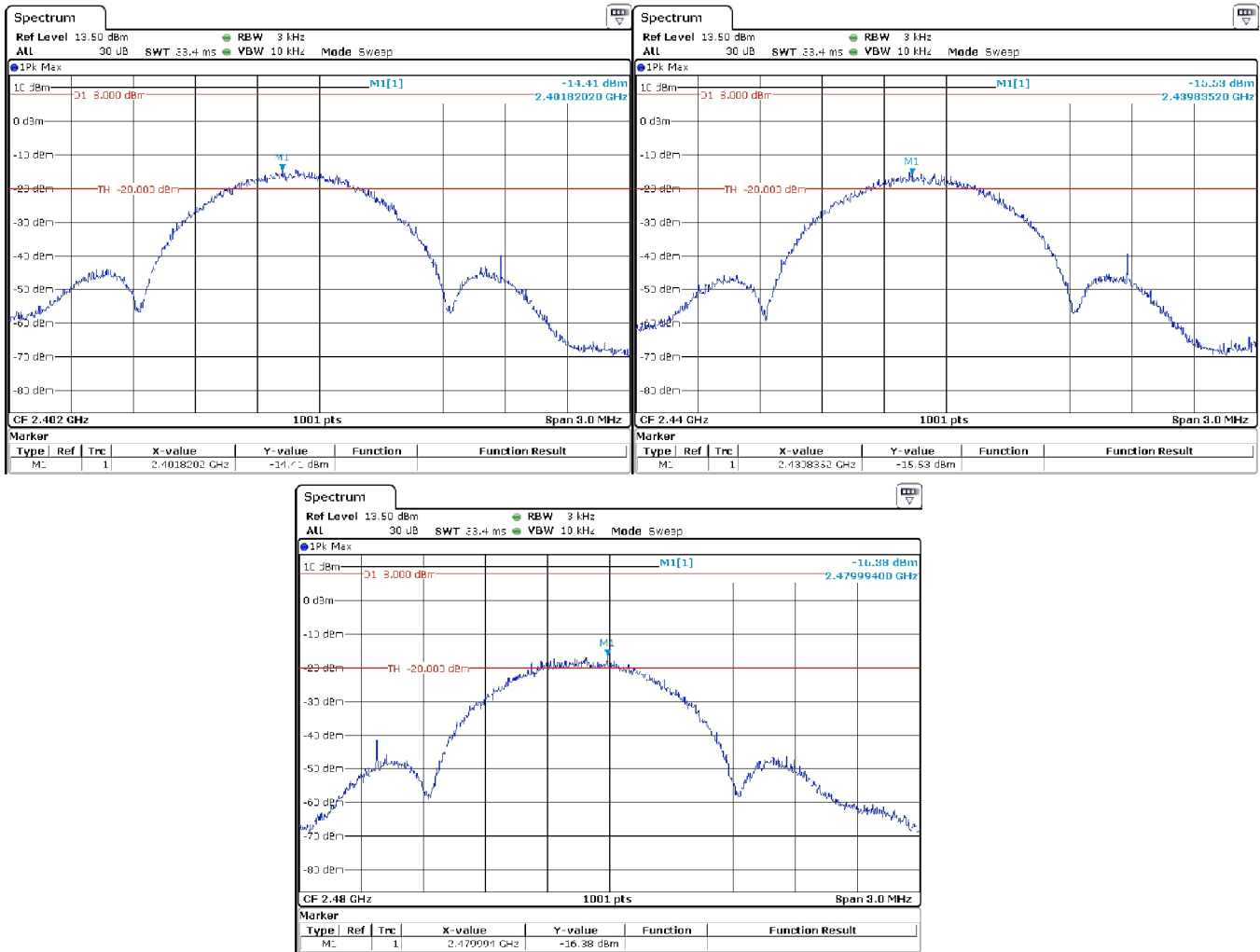

Figure 9: Power Spectral Density Plots.

4.3 Unintentional Emissions

4.3.1 Transmit Chain Spurious Emissions

The results for the measurement of transmit chain spurious emissions at the nominal voltage and temperature are provided in Table 8. Measurements are performed to 10 times the highest fundamental operating frequency.

Table 8: Transmit Chain Spurious Emissions.

| | | | | | |
|------------------------|------------|---------------------|------------------------|------------------------|-----------------|
| Frequency Range | Det | IF Bandwidth | Video Bandwidth | Test Date: | 10-Jun-19 |
| 25 MHz f 1 000 MHz | Pk/QPk | 120 kHz | 300 kHz | Test Engineer: | J. Brunett |
| f > 1 000 MHz | Pk/Avg | 1 MHz | 3 MHz | EUT: | Airlift RMT |
| | | | | Mode: | Cont. Modulated |
| | | | | Meas. Distance: | 3m |

| | | | | | | | | | | | | | FCC/IC | |
|----|--|----------------|-------------|-----------|-----------------|--------------|---------|-------|---------------|-----------------|-------------------|---------|------------------------------|--|
| # | Freq. Start MHz | Freq. Stop MHz | Ant. Used | Ant. Pol. | Table Azim. deg | Ant Height m | Ka dB/m | Kg dB | E3(Pk) dBµV/m | E3(Avg)* dBµV/m | E3 Avg Lim dBµV/m | Pass dB | Comments | |
| 1 | Fundamental Restricted Band Edge (Low Side) | | | | | | | | | | | | | |
| 2 | 2390.0 | 2390.0 | HQR2TO18S01 | H/V | 270 | 1.5 | 30.5 | -0.3 | 36.0 | 25.4 | 54.0 | 28.6 | all channels | |
| 3 | Fundamental Restricted Band Edge (High Side) | | | | | | | | | | | | | |
| 4 | 2483.5 | 2483.5 | HQR2TO18S01 | H/V | 270 | 1.5 | 30.8 | -0.3 | 42.1 | 36.1 | 54.0 | 17.9 | all channels | |
| 5 | Harmonic / Spurious Emissions | | | | | | | | | | | | | |
| 6 | 4804.0 | 4804.0 | HQR2TO18S01 | H/V | 90 | 1.5 | 32.3 | -0.5 | 45.6 | | 54.0 | 8.4 | | |
| 7 | 4882.0 | 4805.0 | HQR2TO18S01 | H/V | 90 | 1.5 | 32.3 | -0.5 | 45.1 | | 54.0 | 9.0 | | |
| 8 | 4960.0 | 4806.0 | HQR2TO18S01 | H/V | 90 | 1.5 | 32.3 | -0.5 | 45.3 | | 54.0 | 8.7 | | |
| 9 | 4000.0 | 6000.0 | HQR2TO18S01 | H/V | all | all | 32.6 | -0.6 | 45.6 | | 54.0 | 8.4 | all channels; max all | |
| 10 | 7206.0 | 7206.0 | HQR2TO18S01 | H/V | 90 | 1.5 | 33.2 | -0.7 | 52.9 | 50.5 | 54.0 | 3.5 | | |
| 11 | 7323.0 | 7323.0 | HQR2TO18S01 | H/V | 90 | 1.5 | 33.3 | -0.7 | 44.3 | | 54.0 | 9.7 | | |
| 12 | 7440.0 | 7440.0 | HQR2TO18S01 | H/V | 90 | 1.5 | 33.4 | -0.7 | 38.5 | | 54.0 | 15.5 | | |
| 13 | 6000.0 | 8400.0 | HQR2TO18S01 | H/V | all | all | 34.3 | -0.8 | 52.9 | | 54.0 | 1.1 | | |
| 14 | 8400.0 | 12500.0 | HQR2TO18S01 | H/V | all | all | 35.6 | -1.1 | 43.7 | | 54.0 | 10.3 | all channels; max all; noise | |
| 15 | 12500.0 | 18000.0 | HQR2TO18S01 | H/V | all | all | 34.2 | -1.6 | 39.2 | | 54.0 | 14.8 | all channels; max all; noise | |
| 16 | 18000.0 | 26000.0 | Horn K | H/V | all | all | 32.0 | 0.0 | 41.7 | | 54.0 | 12.3 | all channels; max all; noise | |
| 17 | | | | | | | | | | | | | | |

*Avg measurements made employing RMS average detector.

4.3.2 Relative Transmit Chain Spurious Emissions

The results for the measurement of transmit chain spurious emissions relative to the fundamental in a 100 kHz receiver bandwidth (at the nominal voltage and temperature) are provided in Figure 10 below.

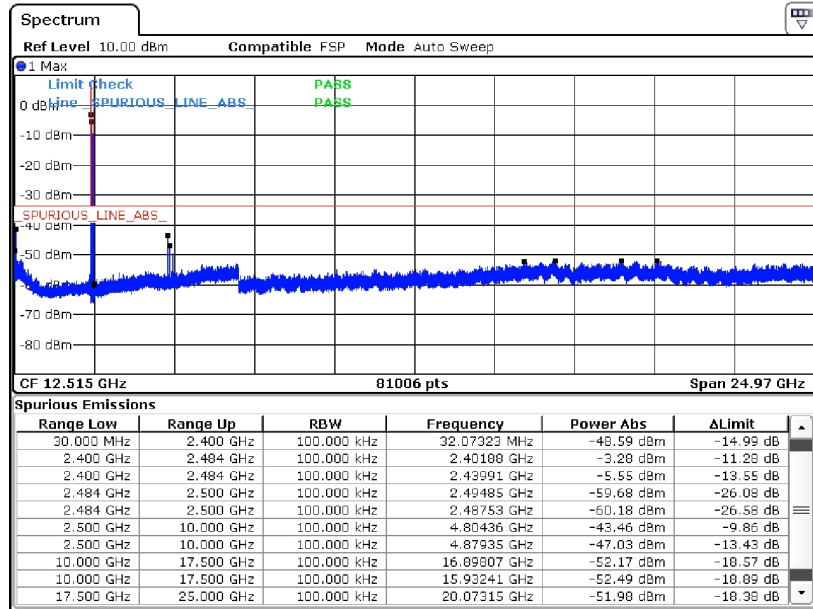

Figure 10: Conducted Transmitter Emissions Measured.

4.3.3 Radiated Digital Spurious

The results for the measurement of digital spurious emissions are not reported herein as all digital emissions were greater than 20 dB below the regulatory limit. Radiation from digital components was measured to 4 GHz, or to five times the maximum digital component operating frequency, whichever is greater.

5 Measurement Uncertainty and Accreditation Documents

The maximum values of measurement uncertainty for the laboratory test equipment and facilities associated with each test are given in the table below. This uncertainty is computed for a 95.45% confidence level based on a coverage factor of $k = 2$.

Table 9: Measurement Uncertainty.

| Measured Parameter | Measurement Uncertainty [†] |
|--|---|
| Radio Frequency | $\pm(f_{Mkr}/10^7 + RBW/10 + (SPN/(PTS - 1))/2 + 1 \text{ Hz})$ |
| Conducted Emm. Amplitude | $\pm 1.9 \text{ dB}$ |
| Radiated Emm. Amplitude (30 – 200 MHz) | $\pm 4.0 \text{ dB}$ |
| Radiated Emm. Amplitude (200 – 1000 MHz) | $\pm 5.2 \text{ dB}$ |
| Radiated Emm. Amplitude ($f > 1000 \text{ MHz}$) | $\pm 3.7 \text{ dB}$ |

[†]Ref: CISPR 16-4-2:2011+A1:2014



Figure 11: Accreditation Documents