

Test Report

FCC ID: 2ANKV-FK-DTS4

Date of issue: Dec. 30, 2020

Report number: MTi20101007-4E2

Sample description: MUSIC BOX

Model(s): DTS4, DTS3

Applicant: Shenzhen lemaga Technology Co., Ltd

Address: Guan Li Da Building 301-31, Qianjin Road 1, Xin'an Ban,
Bao An, Shenzhen, China

Date of test: Oct. 14, 2020 to Dec. 18, 2020

Shenzhen Microtest Co., Ltd.
<http://www.mtitest.com>

This test report is valid for the tested samples only. It cannot be reproduced except in full without prior written consent of Shenzhen Microtest Co., Ltd.

Tel: (86-755) 88850135

Fax: (86-755) 88850136

Web: <http://www.mtitest.com>

E-mail: mti@51mti.com

Address: 101, No. 7, Zone 2, Xinxing Industrial Park, Fuhai Avenue, Xinhe Community, Fuhai Street, Bao' an District, Shenzhen, Guangdong, China.

Table of Contents

1	GENERAL INFORMATION	4
1.1	FEATURE OF EQUIPMENT UNDER TEST (EUT).....	4
1.2	TEST MODE	4
1.3	EUT TEST SETUP.....	5
1.4	ANCILLARY EQUIPMENT	5
2	SUMMARY OF TEST RESULT	6
2.1	OPERATION CHANNEL LIST	6
2.2	TEST CHANNEL	6
3	TEST FACILITIES AND ACCREDITATIONS	7
3.1	TEST LABORATORY	7
3.2	ENVIRONMENTAL CONDITIONS	7
3.3	MEASUREMENT UNCERTAINTY.....	7
3.4	TEST SOFTWARE	7
4	LIST OF TEST EQUIPMENT	8
5	TEST RESULTS.....	8
5.1	ANTENNA REQUIREMENT	9
5.1.1	<i>Standard requirement</i>	9
5.1.2	<i>EUT Antenna</i>	9
5.2	CONDUCTED EMISSION	10
5.2.1	<i>Limits</i>	10
5.2.2	<i>Test Procedures</i>	10
5.2.3	<i>Test Setup</i>	10
5.2.4	<i>Test Result</i>	10
5.3	RADIATED EMISSION.....	15
5.3.1	<i>Limits</i>	15
5.3.2	<i>Test Procedures</i>	16
5.3.3	<i>Test Setup</i>	17
5.3.4	<i>Test Result</i>	17
5.4	OCCUPIED BANDWIDTH.....	21
5.4.1	<i>Test method</i>	21
5.4.2	<i>Test result</i>	21
	PHOTOGRAPHS OF THE TEST SETUP	22
	PHOTOGRAPHS OF THE EUT.....	24

Test Result Certification

Applicant's name: Shenzhen lemega Technology Co., Ltd

Address: Guan Li Da Building 301-31, Qianjin Road 1, Xin'an Ban, Bao An, Shenzhen, China

Manufacture's name: Huizhou LEMEGA Technology Co., Ltd.

Address: No. 120 Shuidian Road, Yuanzhou Town, Huizhou City, Guangdong province, P.R.C 516123

Product name: MUSIC BOX

Trademark: LEMEGA

Model name: DTS4, DTS3

Standards: FCC Part 15C

Test procedure: ANSI C63.10-2013

This device described above has been tested by Shenzhen Microtest Co., Ltd. and the test results show that the equipment under test (EUT) is in compliance with the FCC requirements. And it is applicable only to the tested sample identified in the report.

Tested by:



Danny Xu

Dec. 18, 2020

Reviewed by:

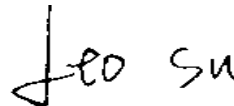

Leo Su

Dec. 30, 2020

Approved by:



Tom Xue

Dec. 30, 2020

1 GENERAL INFORMATION

1.1 Feature of equipment under test (EUT)

Product name:	MUSIC BOX
Model name:	DTS4, DTS3
Model difference:	All the models are the same circuit and RF module, except DTS4 has lithium battery, DTS3 does not have lithium battery
Operation frequency:	115–205 kHz
Modulation type:	FSK
Antenna type:	Coil Antenna
Power supply:	AC 120V/60Hz or DC 11.1V from battery
Battery:	DC 11.1V 4400mAh
Adapter information:	N/A
EUT serial number:	MTi20101007-4-S0001

1.2 Test mode

To investigate the maximum EMI emission characteristics generates from EUT, the test system was pre-scanning tested base on the consideration of following EUT operation mode or test configuration mode which possible have effect on EMI emission level. Each of these EUT operation mode(s) or test configuration mode(s) mentioned above was evaluated respectively.

Test mode	Description
Mode 1	Wireless charging

Note:

1: The test modes were carried out for all operation modes. The final test mode of the EUT was the worst test mode for EMI, and its test data was showed.

2: EUT is tested under full load.

1.3 EUT test setup

See photographs of the test setup in the report for the actual setup and connections between EUT and support equipment.

1.4 Ancillary equipment

Equipment	Model	S/N	Manufacturer
Adapter	BS-E915	/	Shenzhen Times Innovation Technology Co., Ltd
Load	/	/	/

2 Summary of Test Result

Item	FCC Part No.	Description of Test	Result
1	FCC PART 15.203	Antenna requirement	Pass
2	FCC PART 15.207	Conducted emission	Pass
3	FCC PART 15.209	Radiated emission	Pass
4	FCC Part 15.215	20dB bandwidth	Pass

2.1 Operation channel list

Channel	Frequency (kHz)
Low	115
Middle	130
High	205

2.2 Test channel

Channel	Frequency (kHz)
Middle	130

3 Test Facilities and Accreditations

3.1 Test laboratory

Test Laboratory	Shenzhen Microtest Co., Ltd
Location	101, No. 7, Zone 2, Xinxing Industrial Park, Fuhai Avenue, Xinxhe Community, Fuhai Street, Bao' an District, Shenzhen, Guangdong, China.
FCC Registration No.:	448573

3.2 Environmental conditions

Temperature:	15°C~35°C
Humidity	20%~75%
Atmospheric pressure	98kPa~101kPa

3.3 Measurement uncertainty

Measurement Uncertainty for a Level of Confidence of 95 %, $U=2xUc(y)$

RF frequency	1×10^{-7}
RF power, conducted	± 1 dB
Conducted emission(150kHz~30MHz)	± 2.5 dB
Radiated emission(30MHz~1GHz)	± 4.2 dB
Radiated emission (above 1GHz)	± 4.3 dB
Temperature	± 1 degree
Humidity	± 5 %

3.4 Test software

Software Name	Manufacturer	Model	Version
RF Test System	Shenzhen JS tonscond co., ltd	JS1120-3	2.5.77.0418

4 List of test equipment

Equipment No.	Equipment Name	Manufacturer	Model	Serial No.	Calibration date	Due date
MTI-E043	EMI Test Receiver	Rohde&schwarz	ESC17	101166	2020/06/04	2021/06/03
MTI-E044	TRILOG Broadband Antenna	Schwarzbeck	VULB 9163	9163-1338	2020/06/05	2021/06/04
MTI-E047	Amplifier	Hewlett-Packard	8447F	3113A06150	2020/06/04	2021/06/03
MTI-E089	ESG Vector Signal Generator	Agilent	N5182A	MY49060455	2020/06/03	2021/06/02
MTI-E058	ESG Series Analog Signal Generator	Agilent	E4421B	GB40051240	2020/07/03	2021/07/04
MTI-E062	PXA Signal Analyzer	Agilent	N9030A	MY51350296	2020/06/04	2021/06/03
MTI-E066	MXA Signal Analyzer	Agilent	N9020A	MY50143483	2020/06/04	2021/06/03
MTI-E078	Synthesized Sweeper	Agilent	83752A	3610A01957	2020/06/04	2021/06/03
MTI-E079	DC Power Supply	Agilent	E3632A	MY40027695	2020/06/04	2021/06/03
MTI-E021	EMI Test Receiver	Rohde&schwarz	ESCS30	100210	2020/06/04	2021/06/03
MTI-E022	Pulse Limiter	Schwarzbeck	VSTD 9561-F	00679	2020/06/03	2021/06/02
MTI-E023	Artificial mains network	Schwarzbeck	NSLK 8127	NSLK 8127 #841	2020/06/04	2021/06/03
MTI-E046	Active Loop Antenna	Schwarzbeck	FMZB 1519 B	00044	2020/06/05	2021/06/04
MTI-E048	Amplifier	Agilent	8449B	3008A02400	2020/07/03	2021/07/04
MTI-E072	Thermometer Clock Humidity Monitor	-	HTC-1	/	2020/06/07	2021/06/06
MTI-E090	Test Loop Antenna	DATETEK	LA-001	771409634	2020/06/05	2021/06/04

Note: the calibration interval of the above test instruments is 12 months and the calibrations are traceable to international system unit (SI).

5 Test Results

5.1 Antenna requirement

5.1.1 Standard requirement

15.203 requirement: For intentional device, according to 15.203: an intentional radiator shall be designed to ensure that no antenna other than that furnished by the responsible party shall be used with the device

5.1.2 EUT Antenna

The EUT antenna is Coil Antenna. It comply with the standard requirement. In case of replacement of broken antenna the same antenna type must be used.

5.2 Conducted emission

5.2.1 Limits

For the following equipment, when designed to be connected to the public utility (AC) power line the radio frequency voltage that is conducted back onto the AC power line on any frequency or frequencies shall not exceed the limits in the following tables. Compliance with the provisions of this paragraph shall be based on the measurement of the radio frequency voltage between each power line and ground at the power terminal using a 50 μ H/50 ohms line impedance stabilization network (LISN).

Frequency (MHz)	Conducted limit (dB μ V)	
	Quasi-peak	Average
0.15 -0.5	66 - 56 *	56 - 46 *
0.5 -5	56	46
5 -30	60	50

Note:

the limit of " * " marked band means the limitation decreases linearly with the logarithm of the frequency in the range.

5.2.2 Test Procedures

The EUT was placed 0.8 meters from the horizontal ground plane with EUT being connected to the power mains through a line impedance stabilization network (LISN). All other support equipment powered from additional LISN(s). The LISN provide 50 Ohm/ 50uH of coupling impedance for the measuring instrument.

Interconnecting cables that hang closer than 40 cm to the ground plane shall be folded back and forth in the center forming a bundle 30 to 40 cm long.

I/O cables that are not connected to a peripheral shall be bundled in the center. The end of the cable may be terminated, if required, using the correct terminating impedance. The overall length shall not exceed 1 m.

LISN is at least 80 cm from nearest part of EUT chassis.

For the actual test configuration, please refer to the related Item – photographs of the test setup.

5.2.3 Test Setup

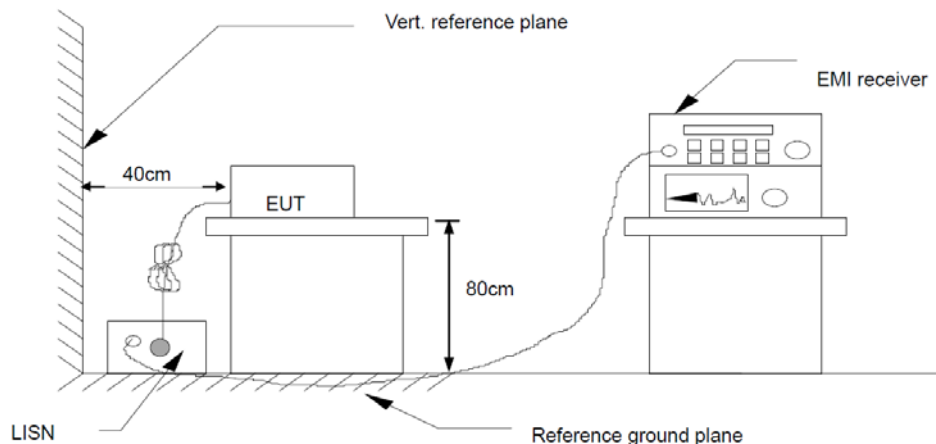

5.2.4 Test Result



EUT:	MUSIC BOX	Model Name:	DTS4
Pressure:	101kPa	Phase:	L
Test voltage:	AC 120V/60Hz	Test mode:	Mode 1

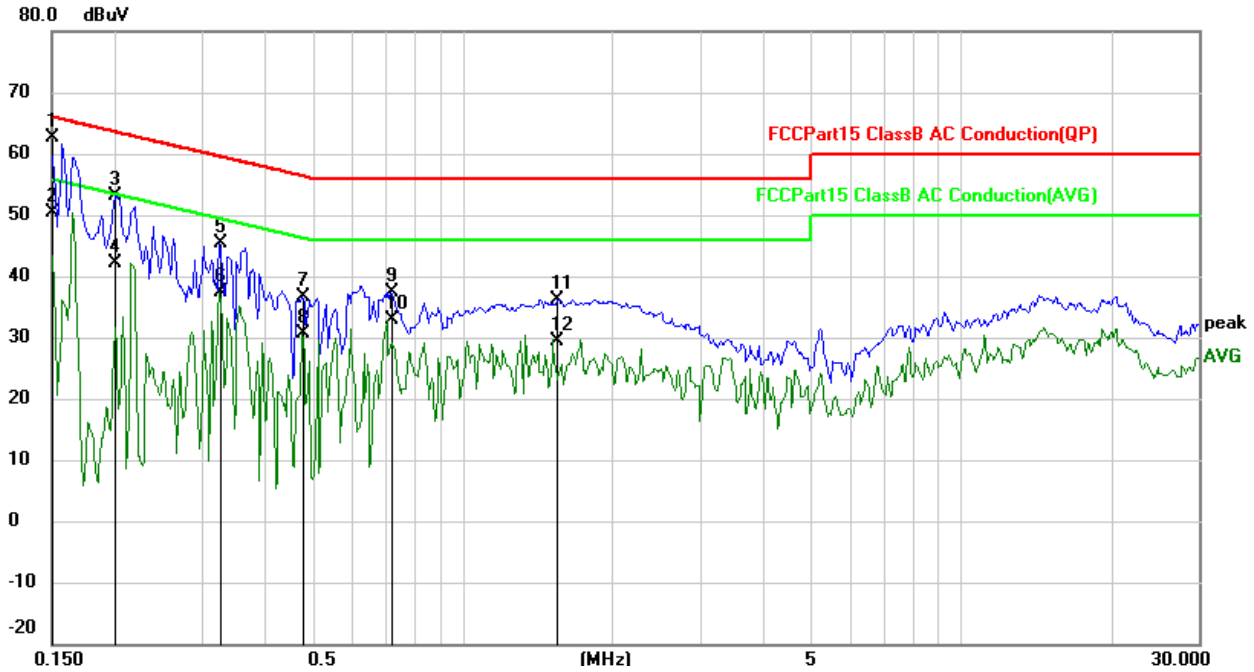

No.	Mk.	Freq. MHz	Reading Level dBuV	Correct Factor dB	Measurement dBuV	Limit dBuV	Over dB	Detector
1	*	0.1500	52.98	9.74	62.72	66.00	-3.28	QP
2		0.1500	40.64	9.74	50.38	56.00	-5.62	AVG
3		0.2006	43.32	9.74	53.06	63.59	-10.53	QP
4		0.2006	32.29	9.74	42.03	53.59	-11.56	AVG
5		0.3256	35.52	9.80	45.32	59.56	-14.24	QP
6		0.3256	27.47	9.80	37.27	49.56	-12.29	AVG
7		0.4781	26.82	9.91	36.73	56.37	-19.64	QP
8		0.4781	20.74	9.91	30.65	46.37	-15.72	AVG
9		0.7164	27.47	9.96	37.43	56.00	-18.57	QP
10		0.7164	22.80	9.96	32.76	46.00	-13.24	AVG
11		1.5483	26.22	10.00	36.22	56.00	-19.78	QP
12		1.5483	19.40	10.00	29.40	46.00	-16.60	AVG



EUT:	MUSIC BOX	Model Name:	DTS4
Pressure:	101kPa	Phase:	N
Test voltage:	AC 120V/60Hz	Test mode:	Mode 1

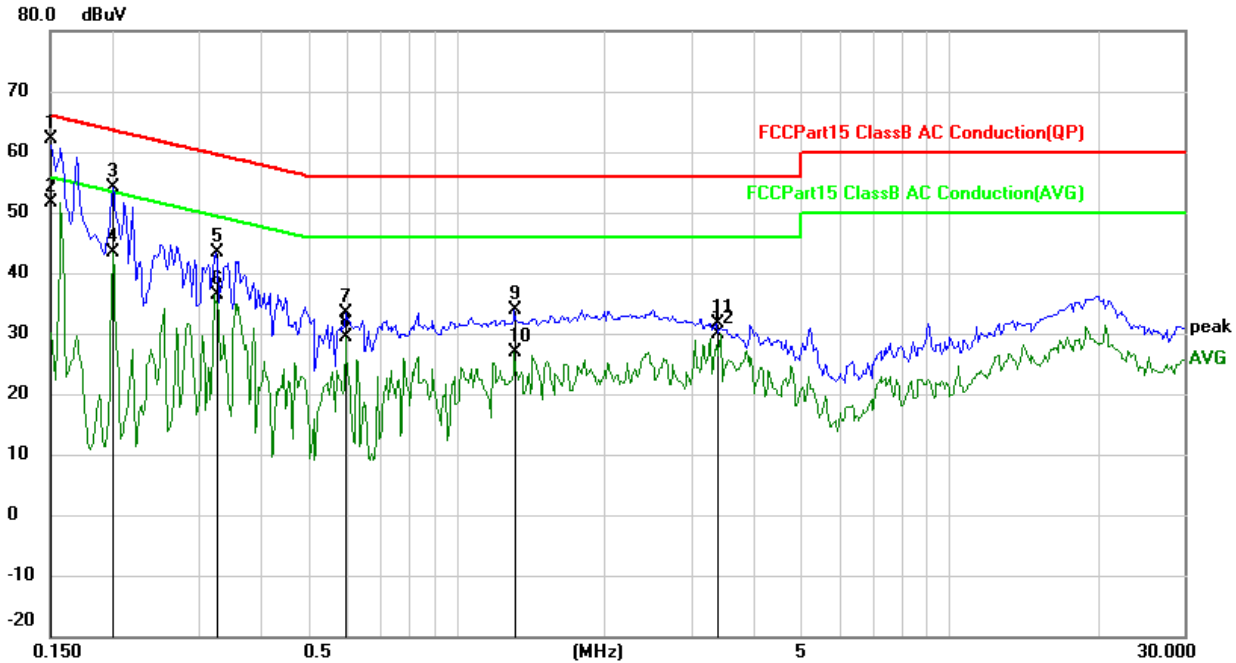

No.	Mk.	Freq. MHz	Reading Level dBuV	Correct Factor dB	Measure- ment dBuV	Limit dBuV	Over dB	Detector
1	*	0.1500	52.37	9.74	62.11	66.00	-3.89	QP
2		0.1500	41.92	9.74	51.66	56.00	-4.34	AVG
3		0.2006	44.30	9.74	54.04	63.59	-9.55	QP
4		0.2006	33.58	9.74	43.32	53.59	-10.27	AVG
5		0.3256	33.50	9.80	43.30	59.56	-16.26	QP
6		0.3256	26.64	9.80	36.44	49.56	-13.12	AVG
7		0.5953	23.47	9.94	33.41	56.00	-22.59	QP
8		0.5953	19.55	9.94	29.49	46.00	-16.51	AVG
9		1.3140	23.96	10.00	33.96	56.00	-22.04	QP
10		1.3140	16.76	10.00	26.76	46.00	-19.24	AVG
11		3.3671	21.66	10.04	31.70	56.00	-24.30	QP
12		3.3671	19.89	10.04	29.93	46.00	-16.07	AVG



EUT:	MUSIC BOX	Model Name:	DTS4
Pressure:	101kPa	Phase:	L
Test voltage:	AC 240V/60Hz	Test mode:	Mode 1

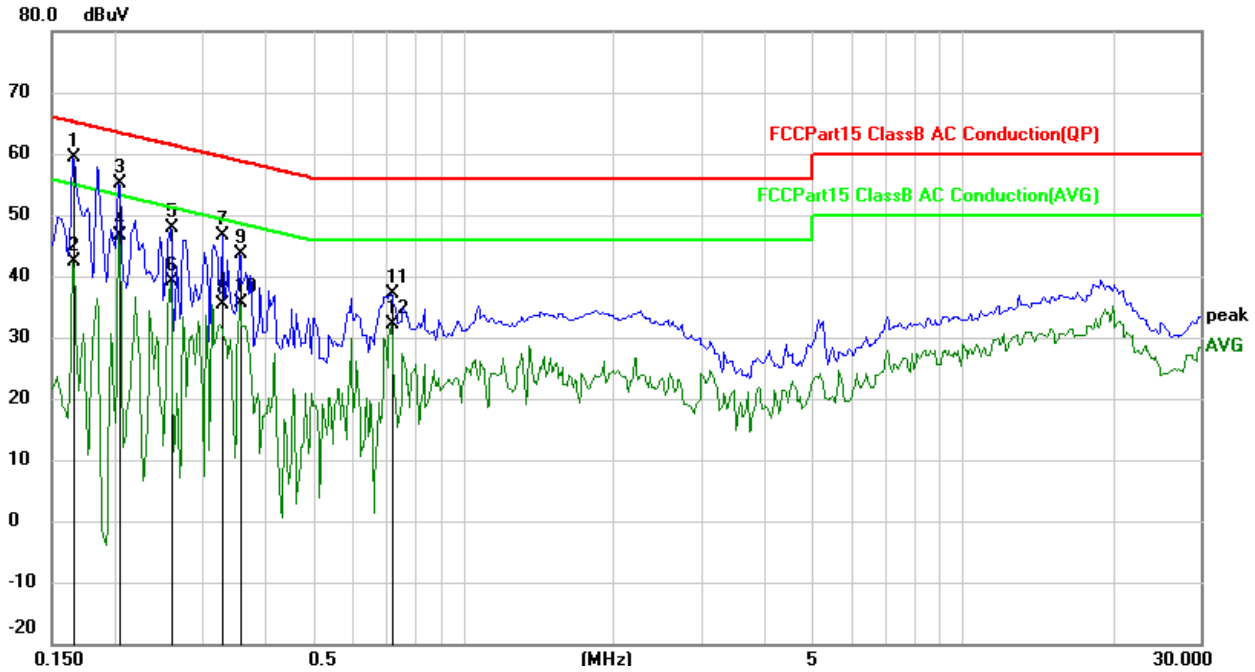

No.	Mk.	Freq. MHz	Reading Level dBuV	Correct Factor dB	Measure- ment dBuV	Limit dBuV	Over dB	Detector
1	*	0.1655	49.63	9.74	59.37	65.18	-5.81	QP
2		0.1655	32.52	9.74	42.26	55.18	-12.92	AVG
3		0.2046	45.38	9.74	55.12	63.42	-8.30	QP
4		0.2046	36.96	9.74	46.70	53.42	-6.72	AVG
5		0.2592	38.20	9.75	47.95	61.46	-13.51	QP
6		0.2592	29.38	9.75	39.13	51.46	-12.33	AVG
7		0.3296	36.91	9.80	46.71	59.46	-12.75	QP
8		0.3296	25.54	9.80	35.34	49.46	-14.12	AVG
9		0.3569	33.87	9.82	43.69	58.80	-15.11	QP
10		0.3569	25.88	9.82	35.70	48.80	-13.10	AVG
11		0.7164	27.13	9.96	37.09	56.00	-18.91	QP
12		0.7164	22.09	9.96	32.05	46.00	-13.95	AVG



EUT:	MUSIC BOX	Model Name:	DTS4
Pressure:	101kPa	Phase:	N
Test voltage:	AC 240V/60Hz	Test mode:	Mode 1

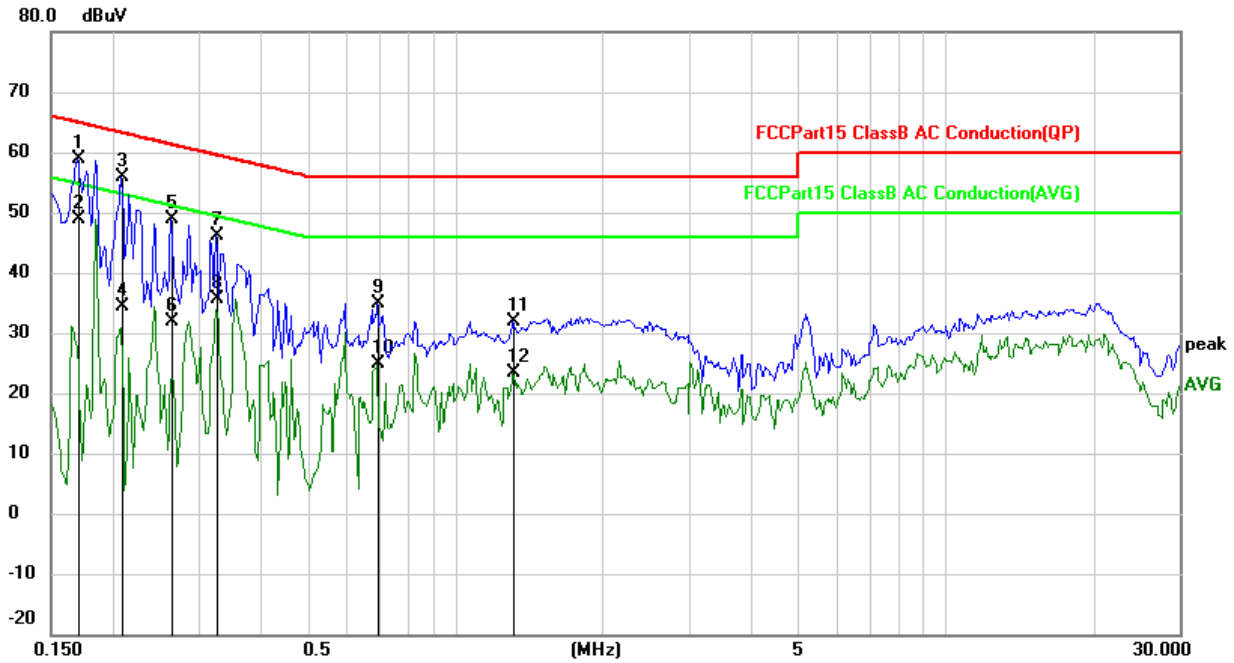

No.	Mk.	Freq.	Reading Level	Correct Factor	Measurement	Limit	Over	Detector
		MHz	dBuV	dB	dBuV	dBuV	dB	
1	*	0.1695	49.26	9.74	59.00	64.98	-5.98	QP
2		0.1695	39.14	9.74	48.88	54.98	-6.10	AVG
3		0.2084	46.05	9.74	55.79	63.27	-7.48	QP
4		0.2084	24.67	9.74	34.41	53.27	-18.86	AVG
5		0.2631	39.05	9.75	48.80	61.33	-12.53	QP
6		0.2631	22.24	9.75	31.99	51.33	-19.34	AVG
7		0.3256	36.27	9.80	46.07	59.56	-13.49	QP
8		0.3256	25.78	9.80	35.58	49.56	-13.98	AVG
9		0.6967	24.97	9.95	34.92	56.00	-21.08	QP
10		0.6967	15.02	9.95	24.97	46.00	-21.03	AVG
11		1.3101	21.98	10.00	31.98	56.00	-24.02	QP
12		1.3101	13.33	10.00	23.33	46.00	-22.67	AVG

5.3 Radiated emission

5.3.1 Limits

In case the emission fall within the restricted band specified on 15.205(a), then the 15.209(a) limit in the table below has to be followed.

Frequencies (MHz)	Field Strength (microrvolts/meter)	Measurement Distance (meters)
0.009~0.490	2400/F(KHz)	300
0.490~1.705	24000/F(KHz)	30
1.705~30.0	30	30
30~88	100	3
88~216	150	3
216~960	200	3
Above 960	500	3

LIMITS OF RADIATED EMISSION MEASUREMENT (Above 1000MHz)

FREQUENCY (MHz)	Class B (dBuV/m) (at 3M)	
	PEAK	AVERAGE
Above 1000	74	54

Notes:

The limit for radiated test was performed according to FCC PART 15C.

The tighter limit applies at the band edges.

Emission level (dBuV/m)=20log Emission level (uV/m).

FREQUENCY RANGE OF RADIATED MEASUREMENT (For unintentional radiators)

Highest frequency generated or Upper frequency of measurement used in the device or on which the device operates or tunes (MHz)	Range (MHz)
Below 1.705	30
1.705 – 108	1000
108 – 500	2000
500 – 1000	5000
Above 1000	5 th harmonic of the highest frequency or 40 GHz, whichever is lower

Spectrum Parameter	Setting
Attenuation	Auto
Start Frequency	1000 MHz
Stop Frequency	10th carrier harmonic
RB / VB (emission in restricted band)	1 MHz / 1 MHz for Peak, 1 MHz / 10Hz for Average

Receiver Parameter	Setting
Attenuation	Auto
Start ~ Stop Frequency	9kHz~150kHz / RB 200Hz for QP
Start ~ Stop Frequency	150kHz~30MHz / RB 9kHz for QP



Start ~ Stop Frequency	30MHz~1000MHz / RB 120kHz for QP
------------------------	----------------------------------

5.3.2 Test Procedures

- a. The measuring distance of at 3 m shall be used for measurements at frequency up to 25GHz. For frequencies above 1GHz, any suitable measuring distance may be used.
- b. The EUT was placed on the top of a rotating table 0.8 meters above the ground at a 3 meter semi-chamber test. The table was rotated 360 degrees to determine the position of the highest radiation.
- c. The height of the equipment or of the substitution antenna shall be 0.8m; above 1GHz, the height was 1.5m, the height of the test antenna shall vary between 1 m to 4 m. Both horizontal and vertical polarizations of the antenna are set to make the measurement.
- d. The initial step in collecting conducted emission data is a spectrum analyzer peak detector mode pre-scanning the measurement frequency range. Significant peaks are then marked and then Quasi Peak detector mode re-measured.
- e. If the Peak Mode measured value compliance with and lower than Quasi Peak Mode Limit, the EUT shall be deemed to meet QP Limits and then no additional QP Mode measurement performed.
- f. For the actual test configuration, please refer to the related Item –EUT Test Photos.
- g. For the radiated emission test above 1GHz:
Place the measurement antenna away from each area of the EUT determined to be a source of emissions at the specified measurement distance, while keeping the measurement antenna aimed at the source of emissions at each frequency of significant emissions, with polarization oriented for maximum response.
- h. The measurement antenna may have to be higher or lower than the EUT, depending on the radiation pattern of the emission and staying aimed at the emission source for receiving the maximum signal. The final measurement antenna elevation shall be that which maximizes the emissions. The measurement antenna elevation for maximum emissions shall be restricted to a range of heights of from 1 m to 4 m above the ground or reference ground plane.

Note: Both horizontal and vertical antenna polarities were tested and performed pretest to three orthogonal axis. The worst case emissions were reported.

5.3.3 Test Setup

Radiated Emission Test-Up Frequency Below 30MHz

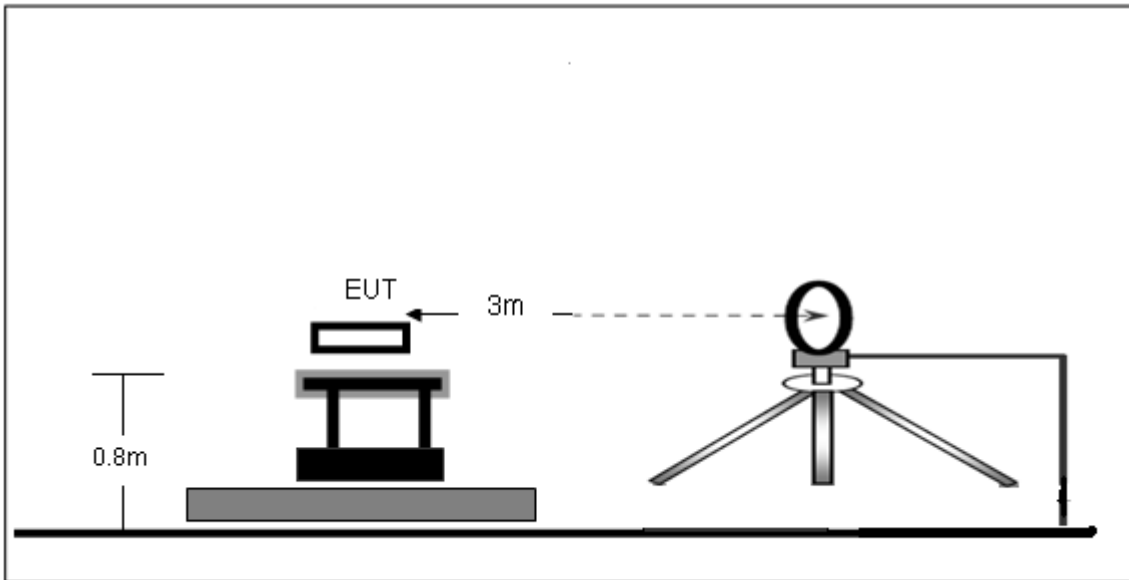

Radiated Emission Test-Up Frequency 30MHz~1GHz

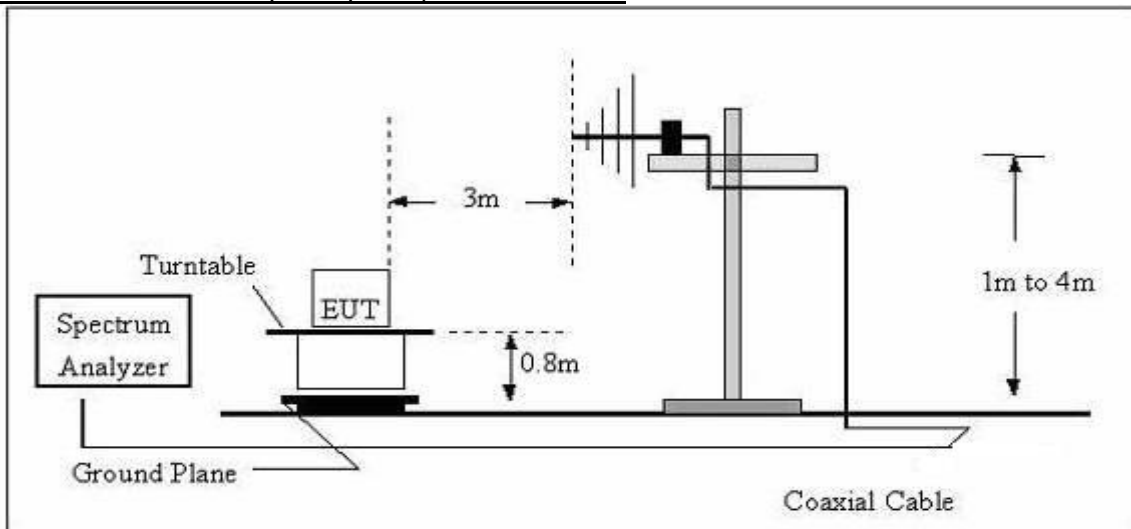

5.3.4 Test Result



Frequency range (9kHz – 30MHz)

EUT:	MUSIC BOX	Model Name:	DTS4
Pressure:	101kPa	Test mode:	Mode 1
Test voltage:	AC 120V/60Hz		

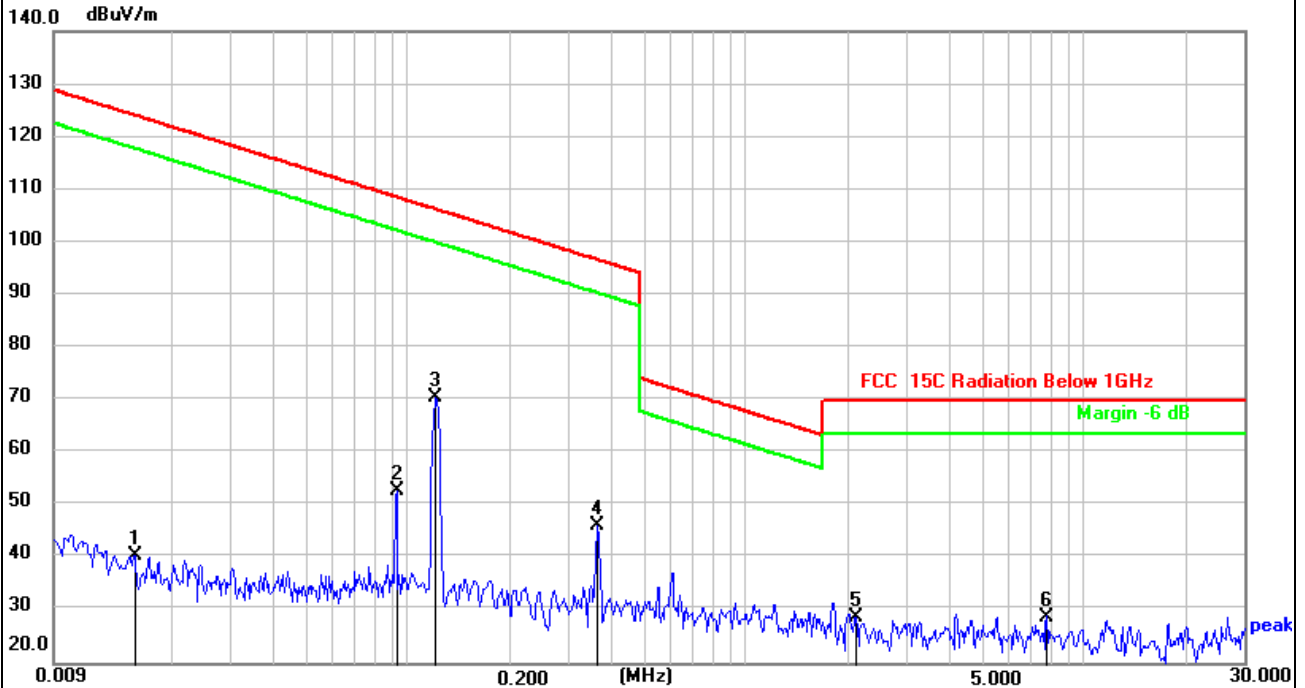

No.	Frequency (MHz)	Reading (dBuV)	Factor (dB/m)	Level (dBuV/m)	Limit (dBuV/m)	Margin (dB)	Detector
1	0.0155	20.17	20.41	40.58	123.80	-83.22	QP
2	0.0931	32.10	20.68	52.78	108.23	-55.45	QP
3 *	0.1216	50.30	20.28	70.58	105.91	-35.33	QP
4	0.3666	26.02	20.25	46.27	96.32	-50.05	QP
5	2.1142	8.43	20.38	28.81	69.50	-40.69	QP
6	7.8041	8.54	20.46	29.00	69.50	-40.50	QP

Frequency range (30MHz – 1GHz)

EUT:	MUSIC BOX	Model Name:	DTS4
Pressure:	101kPa	Polarization:	Vertical
Test voltage:	AC 120V/60Hz	Test mode:	Mode 1

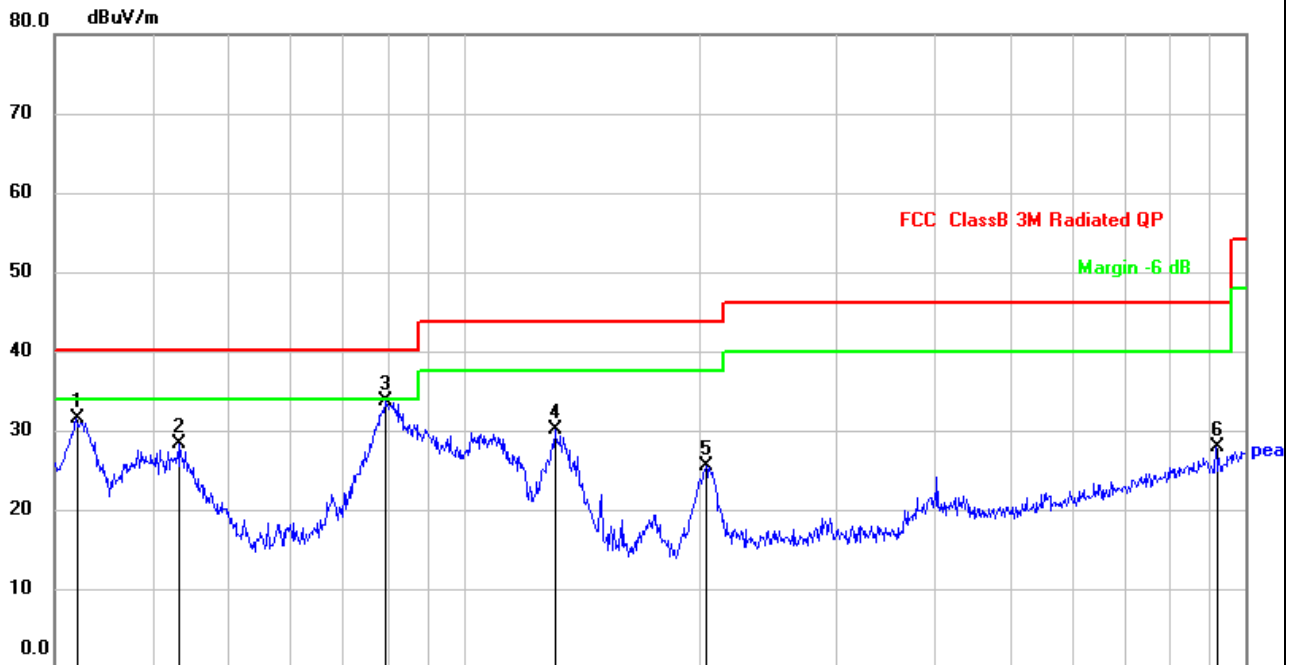

No.	Frequency (MHz)	Reading (dBuV)	Factor (dB/m)	Level (dBuV/m)	Limit (dBuV/m)	Margin (dB)	Detector
1	31.9546	47.42	-15.93	31.49	40.00	-8.51	QP
2	43.3534	42.14	-13.90	28.24	40.00	-11.76	QP
3 *	79.5209	51.74	-18.08	33.66	40.00	-6.34	QP
4	130.8369	47.14	-17.05	30.09	43.50	-13.41	QP
5	204.2377	39.03	-13.62	25.41	43.50	-18.09	QP
6	916.0687	27.31	0.51	27.82	46.00	-18.18	QP



EUT:	MUSIC BOX	Model Name:	DTS4
Pressure:	101kPa	Polarization:	Horizontal
Test voltage:	AC 120V/60Hz	Test mode:	Mode 1

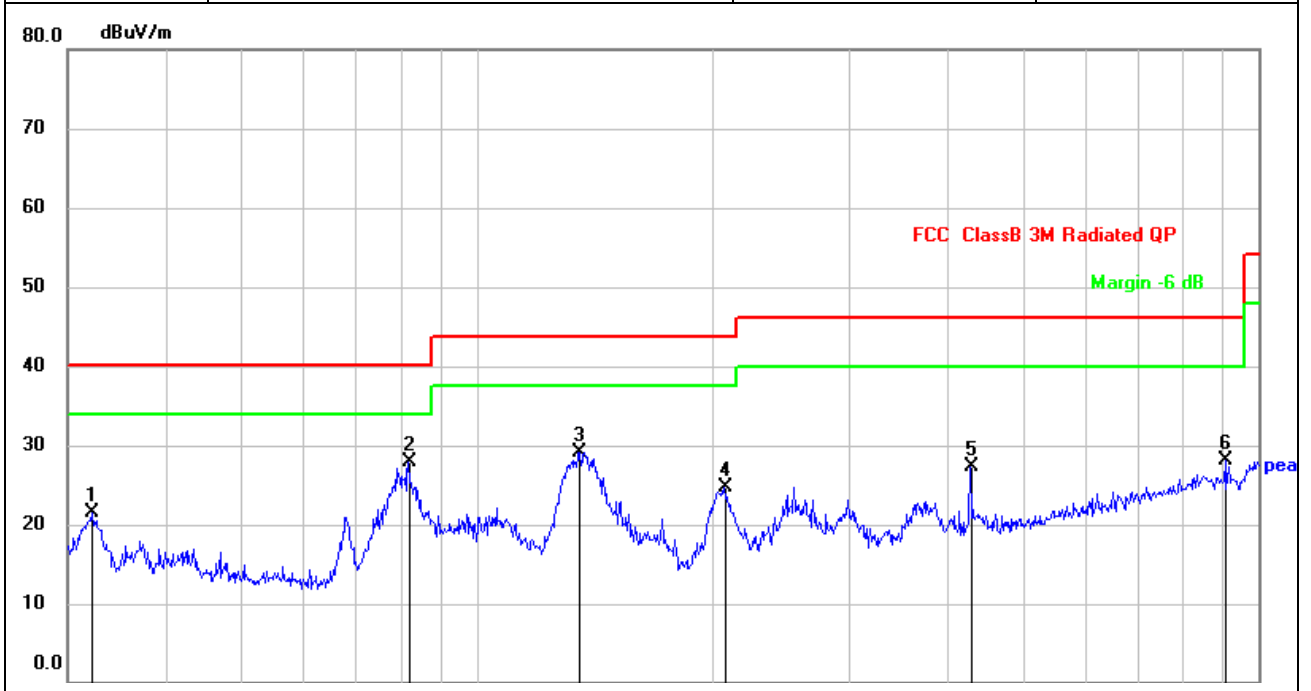

No.	Frequency (MHz)	Reading (dBuV)	Factor (dB/m)	Level (dBuV/m)	Limit (dBuV/m)	Margin (dB)	Detector
1	32.2925	37.33	-15.85	21.48	40.00	-18.52	QP
2 *	81.7833	45.69	-17.76	27.93	40.00	-12.07	QP
3	135.0319	46.30	-17.21	29.09	43.50	-14.41	QP
4	207.1226	38.16	-13.52	24.64	43.50	-18.86	QP
5	428.0193	35.78	-8.44	27.34	46.00	-18.66	QP
6	906.4824	27.80	0.37	28.17	46.00	-17.83	QP

5.4 Occupied bandwidth

5.4.1 Test method

Use the following spectrum analyzer settings:

Span = approximately 2 to 3 times the 20 dB bandwidth, centered on a hopping channel

RBW $\geq 1\%$ of the 20 dB bandwidth

VBW \geq RBW

Sweep = auto

Detector function = peak

Trace = max hold

The EUT should be transmitting at its maximum data rate. Allow the trace to stabilize. Use the marker-to-peak function to set the marker to the peak of the emission. Use the marker-delta function to measure 20 dB down one side of the emission. Reset the marker-delta function, and move the marker to the other side of the emission, until it is (as close as possible to) even with the reference marker level. The marker-delta reading at this point is the 20 dB bandwidth and 99% occupied bandwidth of the emission.

5.4.2 Test result

Frequency (kHz)	20dB emission bandwidth (kHz)	99% occupied bandwidth (kHz)
130	7.901	6.907

Test plots as below:

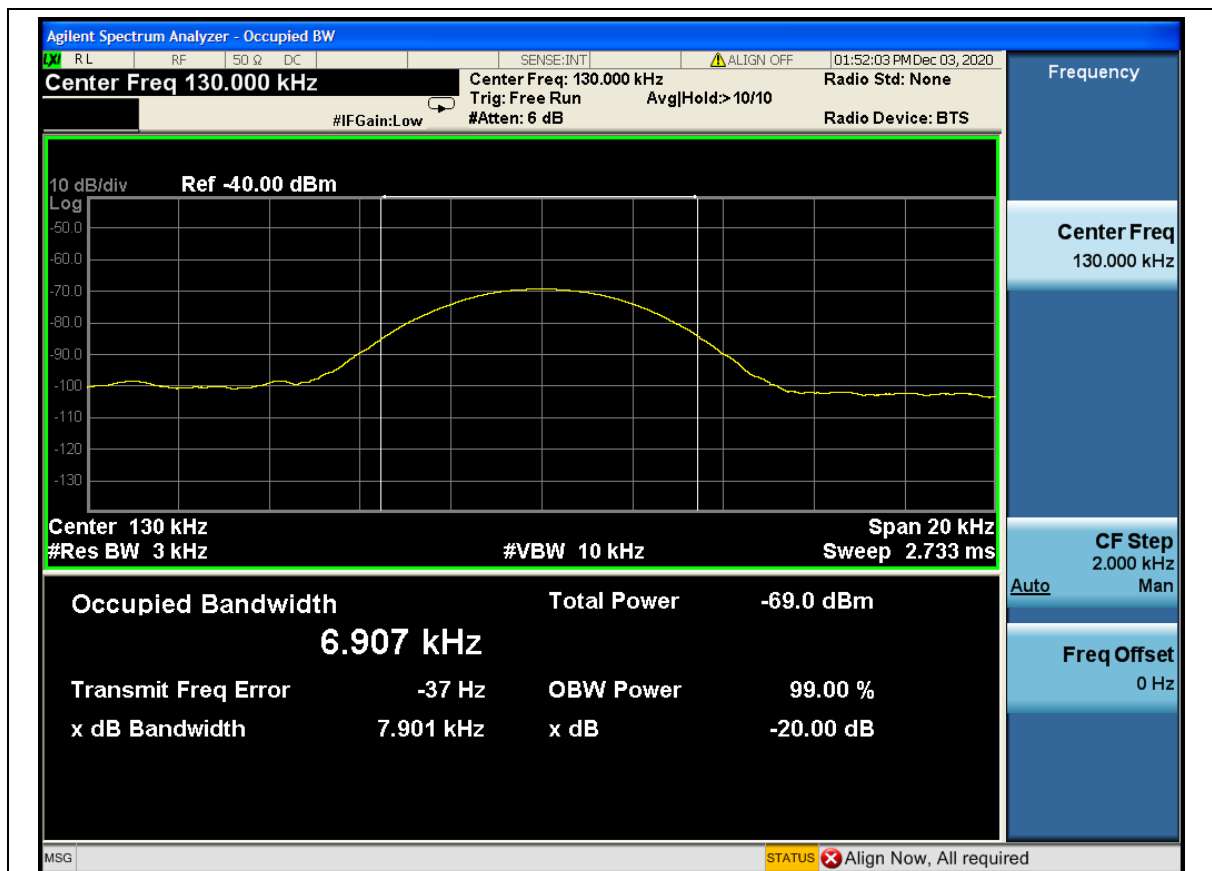

Photographs of the Test Setup

Radiated emission

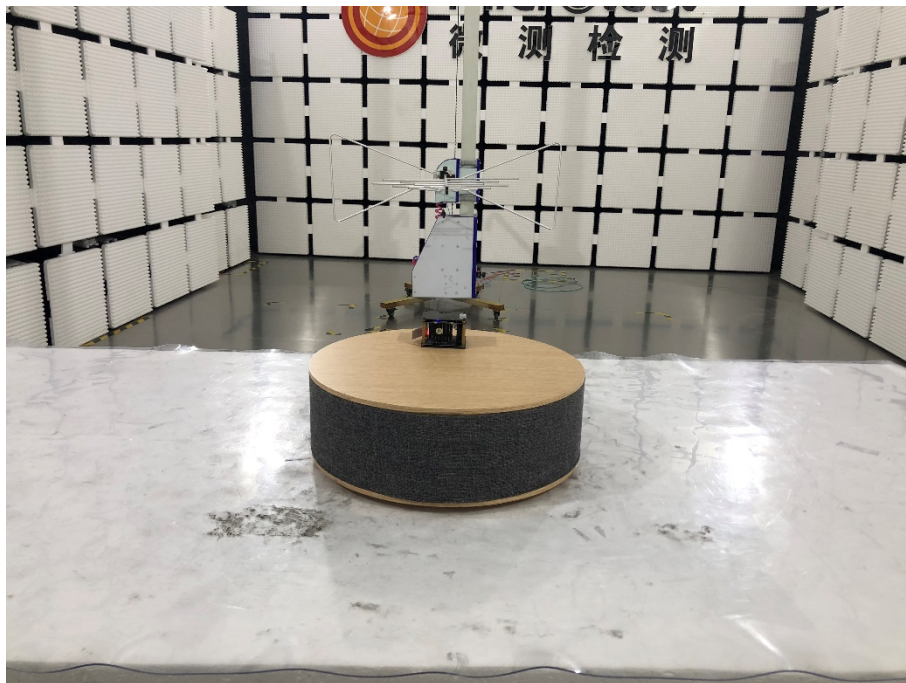

Conducted emission

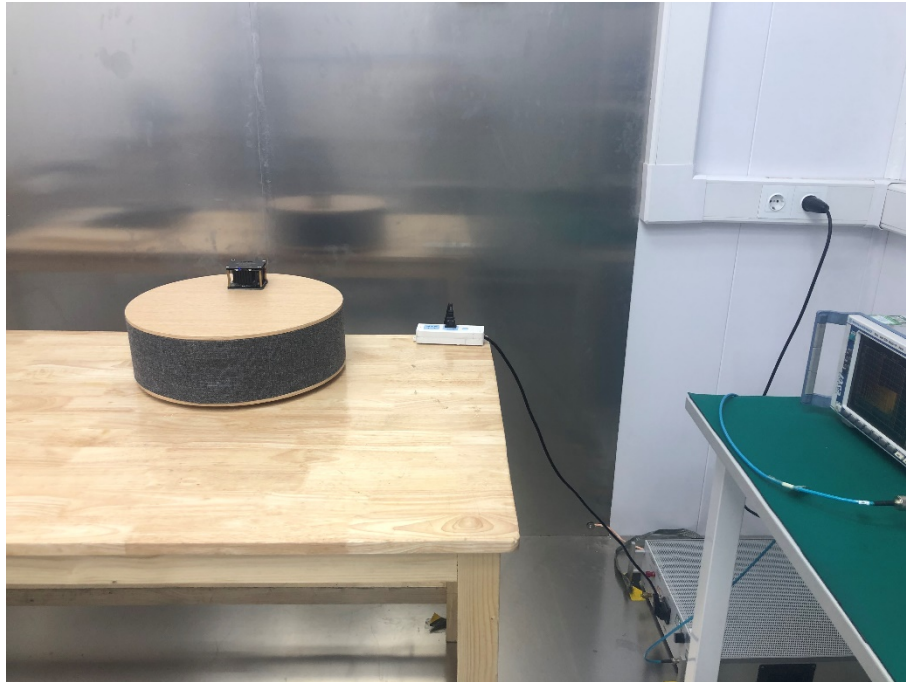



Photographs of the EUT

See the APPENDIX 1: EUT PHOTOS in the report No.: MTi20101007-4E1-1.

----END OF REPORT----