

## FCC Test Report

**Report No.:** RFBEBB-WTW-P23090725

**FCC ID:** 2ANKPC3D9192P

**Test Model:** C3-D9192P

**Received Date:** 2023/7/31

**Test Date:** 2023/8/4 ~ 2023/9/8

**Issued Date:** 2023/10/26

**Applicant:** Magic Control Technology Corporation

**Address:** 10F, No.123, Zhongcheng Rd., Tucheng Dist. New Taipei City 236,  
Taiwan.R.O.C

**Issued By:** Bureau Veritas Consumer Products Services (H.K.) Ltd., Taoyuan Branch  
Lin Kou Laboratories

**Lab Address:** No. 47-2, 14th Ling, Chia Pau Vil., Lin Kou Dist., New Taipei City, Taiwan

**FCC Registration /  
Designation Number:** 198487 / TW2021



This report is governed by, and incorporates by reference, the Conditions of Testing as posted at the date of issuance of this report at <http://www.bureauveritas.com/home/about-us/our-business/cps/about-us/terms-conditions/> and is intended for your exclusive use. Any copying or replication of this report to or for any other person or entity, or use of our name or trademark, is permitted only with our prior written permission. This report sets forth our findings solely with respect to the test samples identified herein. The results set forth in this report are not indicative or representative of the quality or characteristics of the lot from which a test sample was taken or any similar or identical product unless specifically and expressly noted. Our report includes all of the tests requested by you and the results thereof based upon the information that you provided to us. Measurement uncertainty is only provided upon request for accredited tests. Statements of conformity are based on simple acceptance criteria without taking measurement uncertainty into account, unless otherwise requested in writing. You have 60 days from date of issuance of this report to notify us of any material error or omission caused by our negligence or if you require measurement uncertainty; provided, however, that such notice shall be in writing and shall specifically address the issue you wish to raise. A failure to raise such issue within the prescribed time shall constitute your unqualified acceptance of the completeness of this report, the tests conducted and the correctness of the report contents.

## Table of Contents

<b>Release Control Record .....</b>	<b>3</b>
<b>1 Certificate of Conformity .....</b>	<b>4</b>
<b>2 Summary of Test Results .....</b>	<b>5</b>
2.1 Measurement Uncertainty .....	5
2.2 Modification Record .....	5
<b>3 General Information .....</b>	<b>6</b>
3.1 General Description of EUT .....	6
3.2 Channel List .....	7
3.3 Description of Test Modes .....	7
3.3.1 Test Mode Applicability and Tested Channel Detail .....	8
3.4 Description of Support Units .....	9
3.4.1 Configuration of System under Test .....	10
3.5 General Description of Applied Standards .....	13
<b>4 Test Types and Results .....</b>	<b>14</b>
4.1 Radiated Emission and Bandedge Measurement .....	14
4.1.1 Limits of Radiated Emission and Bandedge Measurement .....	14
4.1.2 Test Instruments .....	15
4.1.3 Test Procedures .....	16
4.1.4 Deviation from Test Standard .....	16
4.1.5 Test Set Up .....	17
4.1.6 EUT Operating Conditions .....	17
4.1.7 Test Results .....	18
4.2 Conducted Emission Measurement .....	34
4.2.1 Limits of Conducted Emission Measurement .....	34
4.2.2 Test Instruments .....	34
4.2.3 Test Procedures .....	35
4.2.4 Deviation from Test Standard .....	35
4.2.5 Test Setup .....	35
4.2.6 EUT Operating Conditions .....	35
4.2.7 Test Results .....	36
4.3 20dB Bandwidth Measurement .....	38
4.3.1 Test SetUp .....	38
4.3.2 Test Instruments .....	38
4.3.3 Test Procedure .....	38
4.3.4 Deviation from Test Standard .....	38
4.3.5 EUT Operating Conditions .....	38
4.3.6 Test Results .....	39
<b>5 Pictures of Test Arrangements .....</b>	<b>41</b>
<b>Appendix – Information of the Testing Laboratories .....</b>	<b>42</b>

### Release Control Record

Issue No.	Description	Date Issued
RFBEBB-WTW-P23090725	Original release.	2023/10/26

## 1 Certificate of Conformity

**Product:** USB-C® Dock Dual 4K HDMI™ with 140W GaN PD3.1 Power Adapter

**Brand:** MCT

**Test Model:** C3-D9192P

**Sample Status:** PVT Sample

**Applicant:** Magic Control Technology Corporation

**Test Date:** 2023/8/4 ~ 2023/9/8

**Standards:** 47 CFR FCC Part 15, Subpart C (Section 15.209)  
ANSI C63.10:2013

The above equipment has been tested by **Bureau Veritas Consumer Products Services (H.K.) Ltd., Taoyuan Branch**, and found compliance with the requirement of the above standards. The test record, data evaluation & Equipment Under Test (EUT) configurations represented herein are true and accurate accounts of the measurements of the sample's RF characteristics under the conditions specified in this report.

**Prepared by :**

*Jessica Cheng*

**Date:**

2023/10/26

Jessica Cheng / Senior Specialist

**Approved by :**

*Jeremy Lin*

**Date:**

2023/10/26

Jeremy Lin / Project Engineer

## 2 Summary of Test Results

47 CFR FCC Part 15, Subpart C (Section 15.209)			
FCC Clause	Test Item	Result	Remarks
15.207	AC Power Conducted Emission	Pass	Meet the requirement of limit. Minimum passing margin is -8.12dB at 0.53805MHz
15.209	Radiated Emission Test	Pass	Meet the requirement of limit. Minimum passing margin is -2.7dB at 42.17MHz
15.215 (c)	Emission Bandwidth	-	Reference only

Note: Determining compliance based on the results of the compliance measurement, not taking into account measurement instrumentation uncertainty.

### 2.1 Measurement Uncertainty

Where relevant, the following measurement uncertainty levels have been estimated for tests performed on the EUT as specified in CISPR 16-4-2:

Measurement	Frequency	Expanded Uncertainty (k=2) ( $\pm$ )
Conducted Emissions at mains ports	150kHz ~ 30MHz	2.90 dB
Radiated Emissions up to 1 GHz	9kHz ~ 30MHz	2.38 dB
	30MHz ~ 1000MHz	5.7 dB

### 2.2 Modification Record

There were no modifications required for compliance.

### 3 General Information

#### 3.1 General Description of EUT

Product	USB-C® Dock Dual 4K HDMI™ with 140W GaN PD3.1 Power Adapter
Brand	MCT
Test Model	C3-D9192P
Sample Status	PVT Sample
Power Supply Rating	from adapter
Modulation Type	FSK
Operating Frequency	127.8kHz ~ 148kHz
Antenna Type	Coil antenna
Field Strength	-4.8dBuV/m (@300m) (AV)
Accessory Device	Adapter
Data Cable Supplied	N/A
Maximum Power Output from the Charging Coil	15W

Note:

1. The EUT uses following adapter.

Product	Brand	Model	Remark
AC Adapter	J5create	JUP17140	AC Input : 100V-240Vac 50/60Hz, 1.8A Max DC Output : PD 3.1 5V=3A, 9V=3A, 12V=3A, 15V=3A, 20V=5A, 28V=5A (140W Max) Shielded Type C cable (1.2m) with one ferrite core. Non-shielded AC 3-Pin cable (1.3m)

2. Due to radiated measurements are made and the antenna gain is already accounted for this device, so provide an antenna datasheet and/or antenna measurement report is not required. The antenna dimensions and pictures (include antenna wire length if have) are stated in EUT photo exhibit.

3. The above EUT information is declared by manufacturer and for more detailed features description, please refer to the manufacturer's specifications or user's manual.

### 3.2 Channel List

3 channels are provided for EUT:

Channel	Freq.
1	127.8kHz
2	147.2kHz
3	148kHz

### 3.3 Description of Test Modes

The following test frequency is provided to this EUT:

Tested Frequency (kHz)	Test Mode	
147.2	with Load	Operating
127.8	with iPhone	
127.8	Standby Mode	

### 3.3.1 Test Mode Applicability and Tested Channel Detail

<b>Pre-Scan:</b>	1. For pre-scan EUT Charging mode with Load / EUT Charging mode with iPhone and find the worst case (EUT Charging mode with Load) as a representative test condition. 2. The EUT has been pre-tested for upright and lying down positions. The worst case was found when positioned lying down.
<b>Worst Case:</b>	EUT Charging mode with Load is the worse case. EUT lying down is the worse case.

EUT Configure Mode	Applicable To			Description
	RE<1G	PLC	BW	
A	√	√	√	Charging mode with max Load (147.2kHz)
B	√	-	√	Standby mode (127.8kHz)

Where **RE<1G**: Radiated Emission below 1GHz      **PLC**: Power Line Conducted Emission  
**BW**: 20dB Bandwidth

#### Radiated Emission Test (Below 1GHz):

- Pre-Scan has been conducted to determine the worst-case mode from all possible combinations between available modulations, data rates and antenna ports and channels (if EUT with antenna diversity architecture).
- Following channel(s) was (were) selected for the final test as listed below.

EUT Configure Mode	Operating Frequency (kHz)	Tested Frequency (kHz)
A	127.8 ~ 148	147.2
B	127.8 ~ 148	127.8

#### Power Line Conducted Emission Test:

- Pre-Scan has been conducted to determine the worst-case mode from all possible combinations between available modulations, data rates and antenna ports and channels (if EUT with antenna diversity architecture).
- Following channel(s) was (were) selected for the final test as listed below.

EUT Configure Mode	Operating Frequency (kHz)	Tested Frequency (kHz)
A	127.8 ~ 148	147.2

#### 20dB Bandwidth Test:

- Pre-Scan has been conducted to determine the worst-case mode from all possible combinations between available modulations, data rates and antenna ports and channels (if EUT with antenna diversity architecture).
- Following channel(s) was (were) selected for the final test as listed below.

EUT Configure Mode	Operating Frequency (kHz)	Tested Frequency (kHz)
A	127.8 ~ 148	147.2
B	127.8 ~ 148	127.8

#### Test Condition:

Applicable To	Environmental Conditions	Input Power	Tested by
<b>RE&lt;1G</b>	23 deg. C, 69% RH	120Vac, 60Hz	William Su
<b>PLC</b>	25 deg. C, 73% RH	120Vac, 60Hz	Jed Wu
<b>BW</b>	25 deg. C, 76% RH	120Vac, 60Hz	Dalen Dai



### 3.4 Description of Support Units

The EUT has been tested as an independent unit together with other necessary accessories or support units. The following support units or accessories were used to form a representative test configuration during the tests.

ID	Product	Brand	Model No.	Serial No.	FCC ID	Remarks
A	NB	ASUS	UX3402Z	N/A	PD9AX211NG	Supplied by applicant
B	MONITOR	ASUS	PA279CV	M7LMTF235956	DoC	Provided by Lab
C	MONITOR	ASUS	PA279CV	M7LMTF235959	DoC	Provided by Lab
D	SSD	SEAGATE	SRD0FV3	NABG035A	DoC	Supplied by applicant
E	SSD	SEAGATE	SRD0FV3	NABG03BZ	DoC	Supplied by applicant
F	Earphone/MIC	Logitech	H151	1703ALA01858	N/A	Supplied by applicant
G	LOAD	Kamera	YBZ	N/A	N/A	Supplied by applicant
H	Micro SD CARD	SONY	16GB	N/A	N/A	Supplied by applicant
I	SSD	SEAGATE	SRD0FV3	NABG03ZA	DoC	Supplied by applicant
J	SSD	SEAGATE	SRD0FV3	NABG035M	DoC	Supplied by applicant
K	SD CARD	Transcend	4GB	N/A	N/A	Supplied by applicant
L	PRINTER	HP	HP Officejet Pro 251dW	N/A	N/A	Provided by Lab
M	MOUSE	DELL	MOCZUL	N/A	N/A	Provided by Lab
N	NB	LENOVO	T480	N/A	N/A	Provided by Lab

ID	Cable Descriptions	Qty.	Length(m)	Shielding (Yes/No)	Cores (Qty.)	Remarks
1	Type C cable	1	0.65	Y	0	Accessory of EUT
2	HDMI cable	1	2.0	Y	0	Supplied by applicant
3	HDMI cable	1	2.0	Y	0	Supplied by applicant
4	USB Type A to C cable	1	1	Y	0	Supplied by applicant
5	USB Type A to C cable	1	1	Y	0	Supplied by applicant
6	USB Type C to C cable	1	0.5	Y	0	Supplied by applicant
7	USB Type C to C cable	1	0.5	Y	0	Supplied by applicant
8	Audio cable	1	1.8	N	0	Supplied by applicant
9	Type C cable	1	1.2	Y	1	Supplied by applicant
10	AC power(3pin) cable	1	1.3	N	0	Supplied by applicant
11	RJ45 (Cat. 5e) cable	1	10	N	0	Provided by Lab
12	USB cable	1	1.8	Y	0	Provided by Lab
13	AC Power Cable	1	1.8	N	0	Provided by Lab
14	AC Power Cable	1	1.8	N	0	Provided by Lab
15	AC Power Cable	1	1.8	N	0	Provided by Lab
16	USB cable	1	1.8	Y	0	Provided by Lab

### 3.4.1 Configuration of System under Test

Conducted Emissions:

Charging Mode:

Test Mode A

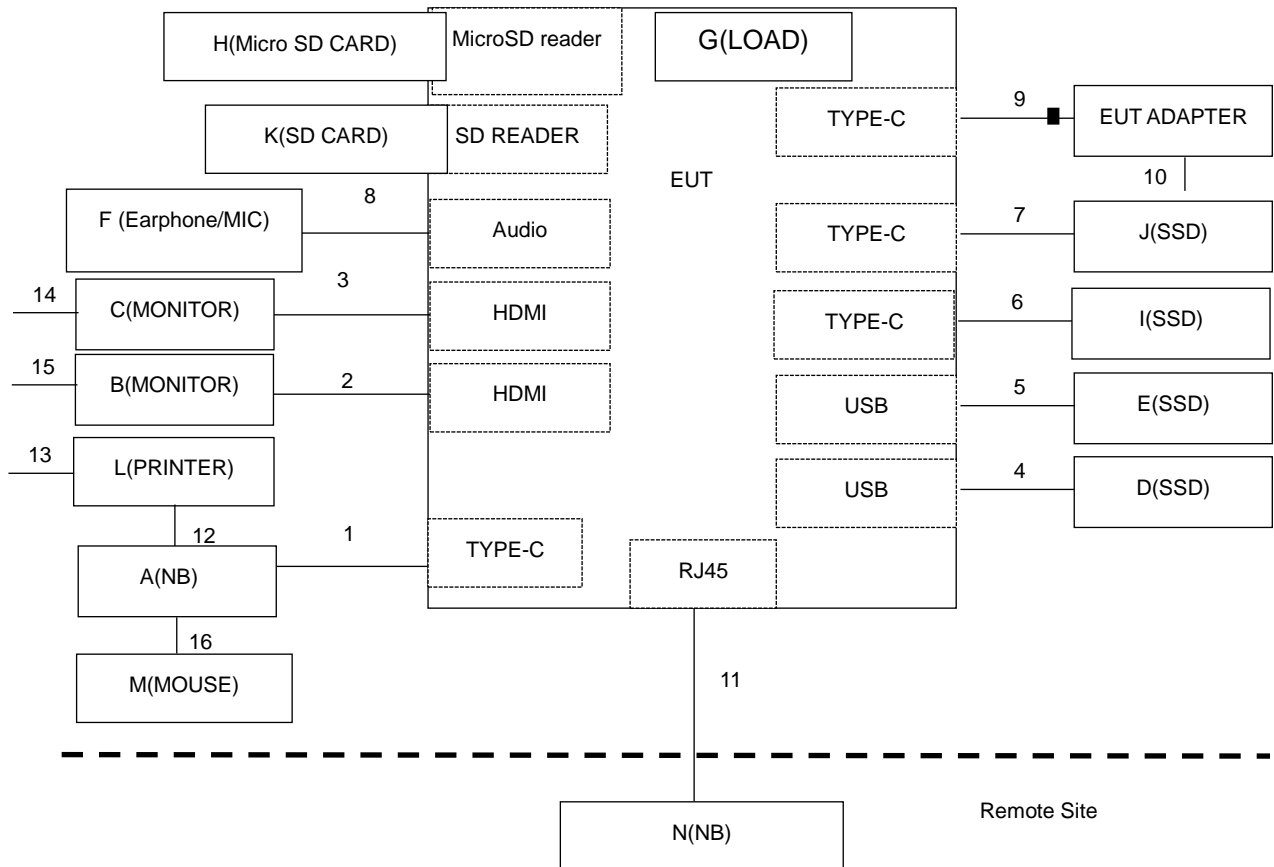

Radiated Emissions

Charging Mode:  
Test Mode A

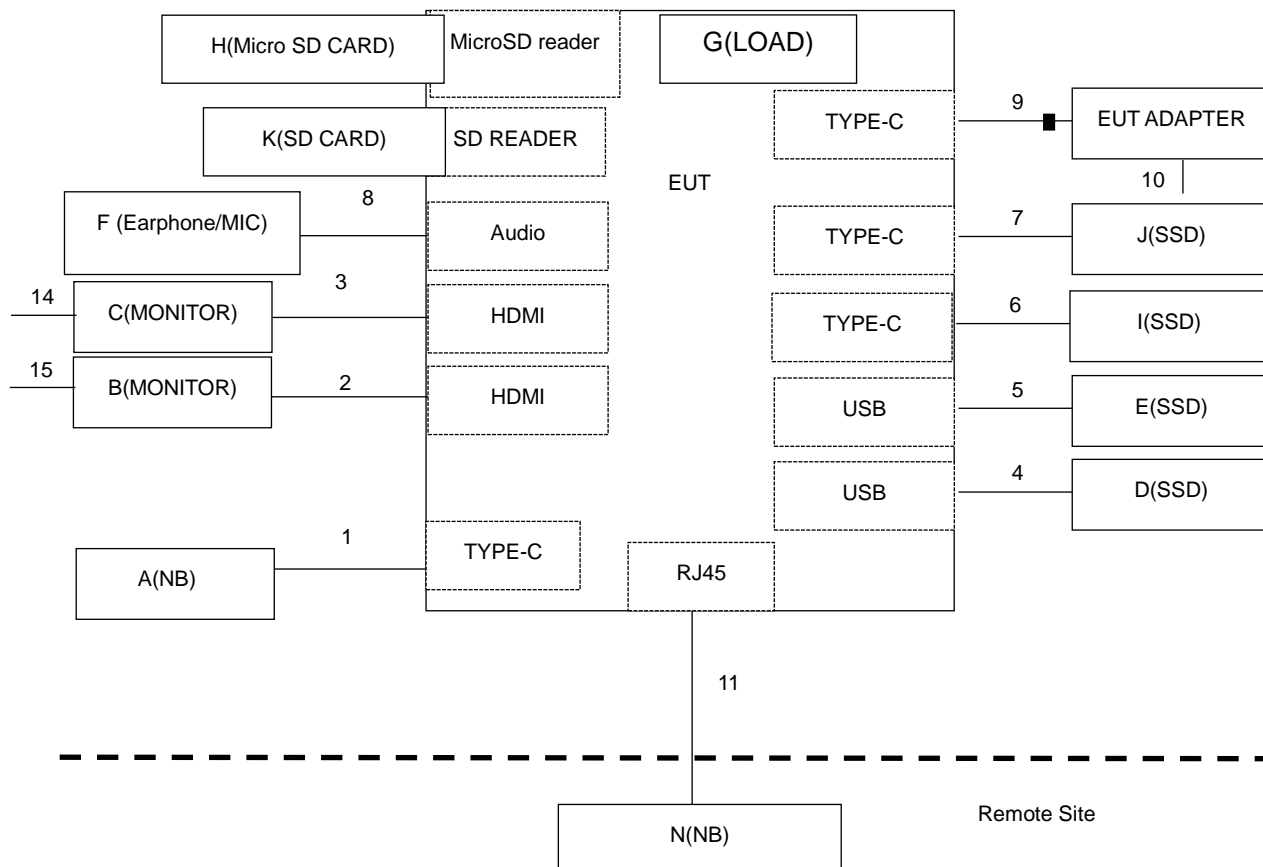

Standby Mode:  
Test Mode B

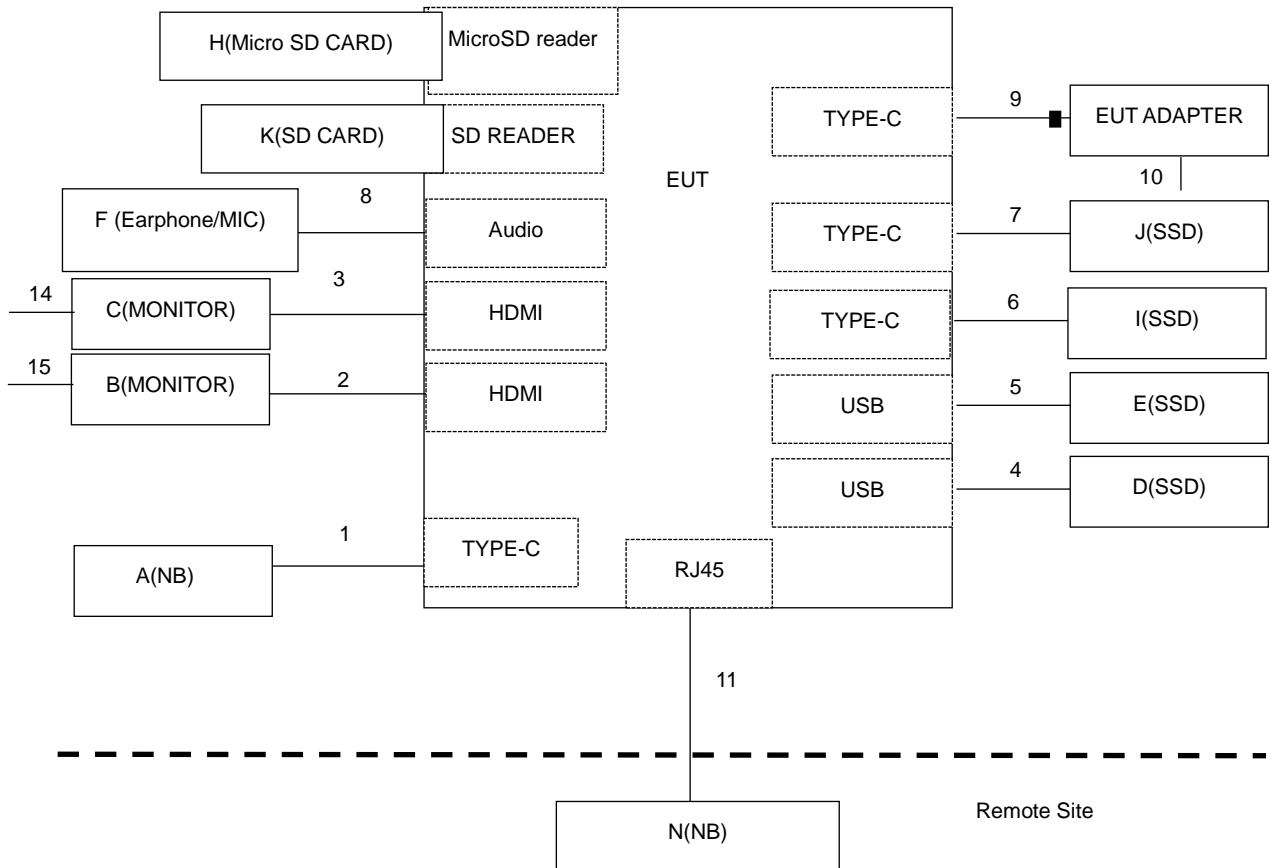

### **3.5 General Description of Applied Standards**

The EUT is a RF Product. According to the specifications of the manufacturer, it must comply with the requirements of the following standards:

#### **47 CFR FCC Part 15, Subpart C (Section 15.209)**

ANSI C63.10-2013

All test items have been performed and recorded as per the above standards.

#### 4 Test Types and Results

##### 4.1 Radiated Emission and Bandedge Measurement

##### 4.1.1 Limits of Radiated Emission and Bandedge Measurement

###### For Frequency Below 30MHz

Frequency (MHz)	Field Strength (dBuV/m)		Measurement Distance (meters)
	uV/m	dBuV/m	
0.009 – 0.490	2400 / F (kHz)	48.52-13.80	300
0.490 – 1.705	24000 / F (kHz)	33.80-22.97	30
1.705 – 30.0	30	29.54	30

###### For Frequency Between 30-1000MHz

Frequency (MHz)	Field Strength (dBuV/m)		Measurement Distance (meters)
	uV/m	dBuV/m	
30-88	100	40.0	3
88-216	150	43.5	3
216-960	200	46.0	3
Above 960	500	54.0	3

#### 4.1.2 Test Instruments

Description & Manufacturer	Model no.	Serial No.	Calibrated Date	Calibrated Until
MXE EMI Receiver Agilent	N9038A	MY51210129	2023/3/24	2024/3/23
MXE EMI Receiver Agilent	N9038A	MY51210137	2023/6/5	2024/6/4
Signal Analyzer R&S	FSV40	101544	2023/5/9	2024/5/8
Preamplifier EMCI	EMC001340	980269	2023/6/27	2024/6/26
Loop Antenna EMCI	EM-6879	269	2022/9/19	2023/9/18
RF Coaxial Cable Pacific	8D-FB	Cable-CH6-02	2023/6/27	2024/6/26
Turn Table ADT	TT100	0306	NA	NA
Tower ADT	AT100	0306	NA	NA
Software BVADT	Radiated_V8.7.08	NA	NA	NA

- NOTE:**
1. The calibration interval of the above test instruments is 12 months. And the calibrations are traceable to NML/ROC and NIST/USA.
  2. The test was performed in Linkou 966 Chamber 6 (CH 6).
  3. Tested Date: 2023/8/4~ 2023/8/25

#### 4.1.3 Test Procedures

##### For Radiated emission below 30MHz

- a. The EUT was placed on the top of a rotating table 0.8 meters above the ground at a 3 meter chamber room. The table was rotated 360 degrees to determine the position of the highest radiation.
- b. The EUT was set 3 meters away from the interference-receiving antenna, which was mounted on the top of a variable-height antenna tower.
- c. Parallel, perpendicular, and ground-parallel orientations of the antenna are set to make the measurement.
- d. For each suspected emission, the EUT was arranged to its worst case and the rotatable table was turned from 0 degrees to 360 degrees to find the maximum reading.
- e. The test-receiver system was set to Quasi-Peak Detect Function and Specified Bandwidth with Maximum Hold Mode, except for the frequency band (9kHz-90kHz, 110kHz-490kHz) set to average detect function and peak detect function.

Note:

1. The resolution bandwidth and video bandwidth of test receiver/spectrum analyzer is 200Hz at frequency range 9kHz to 150kHz.
2. The resolution bandwidth and video bandwidth of test receiver/spectrum analyzer is 9kHz at frequency range 150kHz to 30MHz.

##### For Radiated emission above 30MHz

- a. The EUT was placed on the top of a rotating table 0.8 meters (for below 1GHz) above the ground at 3 meter chamber room for test. The table was rotated 360 degrees to determine the position of the highest radiation.
- b. The EUT was set 3 meters away from the interference-receiving antenna, which was mounted on the top of a variable-height antenna tower.
- c. The height of antenna is varied from one meter to four meters above the ground to determine the maximum value of the field strength. Both horizontal and vertical polarizations of the antenna are set to make the measurement.
- d. For each suspected emission, the EUT was arranged to its worst case and then the antenna was tuned to heights from 1 meter to 4 meters and the rotatable table was turned from 0 degrees to 360 degrees to find the maximum reading.
- e. The test-receiver system was set to quasi-peak detect function and specified bandwidth with maximum hold mode when the test frequency is below 1 GHz.

Note:

1. The resolution bandwidth and video bandwidth of test receiver/spectrum analyzer is 120kHz for Quasi-peak detection (QP) at frequency below 1GHz.
2. All modes of operation were investigated and the worst-case emissions are reported.

#### 4.1.4 Deviation from Test Standard

No deviation.



#### 4.1.5 Test Set Up

For Radiated emission below 30MHz

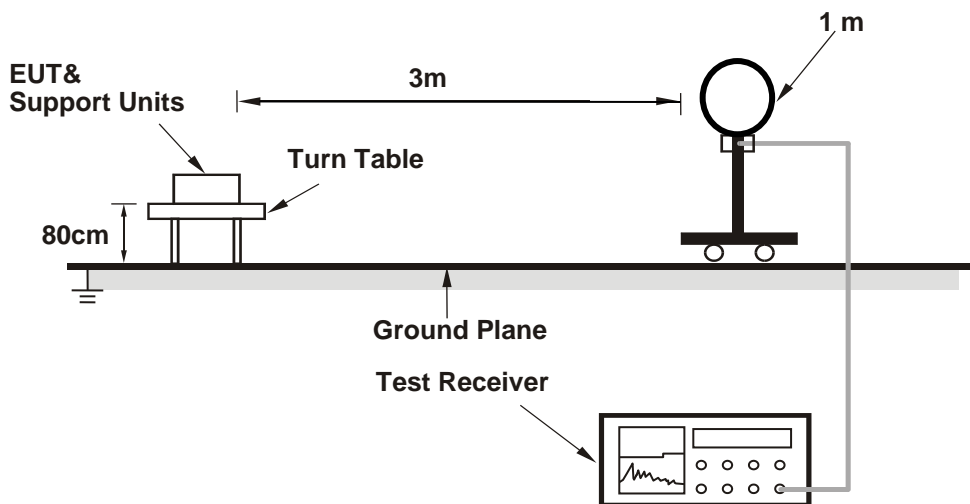

For Radiated emission 30MHz to 1GHz

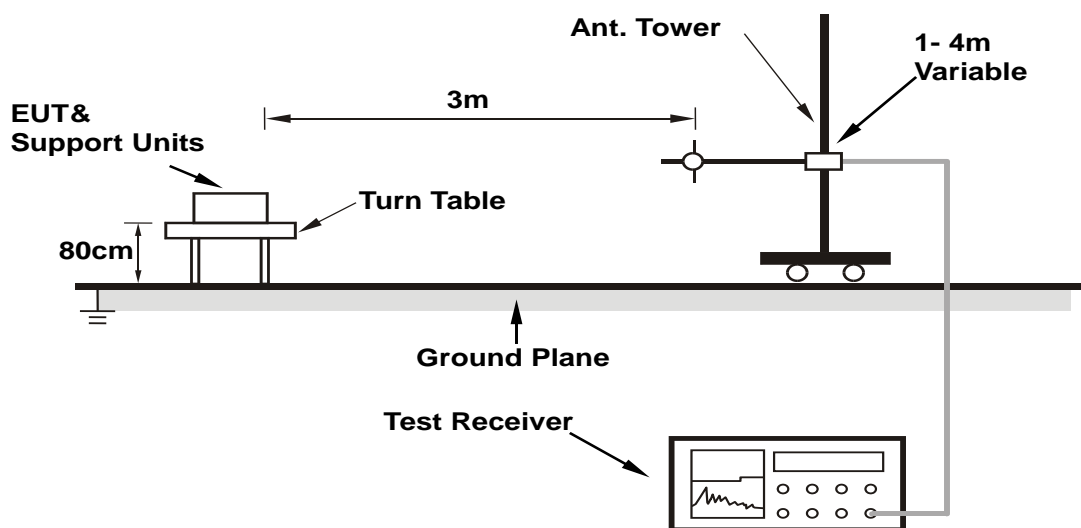

For the actual test configuration, please refer to the attached file (Test Setup Photo).

#### 4.1.6 EUT Operating Conditions

Set the EUT under transmission condition continuously at specific channel frequency.

### 4.1.7 Test Results

Below 30MHz Data:

Mode A

<b>Test Frequency</b>	147.2kHz	<b>Detector Function</b>	Peak (PK)
<b>Frequency Range</b>	9 kHz ~ 490 kHz		Average (AV)

Antenna Polarity : Parallel								
No	Frequency (MHz)	Emission Level (dBuV/m)	Limit (dBuV/m)	Margin (dB)	Antenna Height (m)	Table Angle (Degree)	Raw Value (dBuV)	Correction Factor (dB/m)
1	0.1110	-25.5 PK	46.7	-72.2	1.00	255	34.1	-59.6
2	0.1110	-26.7 AV	26.7	-53.4	1.00	255	32.9	-59.6
3	*0.1472	-7.1 PK	44.2	-51.3	1.00	98	54.0	-61.1
4	*0.1472	-8.2 AV	24.2	-32.4	1.00	98	52.9	-61.1
5	0.2944	-20.8 PK	38.2	-59.0	1.00	74	46.0	-66.8
6	0.2944	-21.9 AV	18.2	-40.1	1.00	74	44.9	-66.8
7	0.4416	-28.5 PK	34.7	-63.2	1.00	236	41.0	-69.5
8	0.4416	-29.6 AV	14.7	-44.3	1.00	236	39.9	-69.5
9	0.4890	-57.7 PK	33.8	-91.5	1.00	168	12.6	-70.3
10	0.4890	-58.4 AV	13.8	-72.2	1.00	168	11.9	-70.3

**Remarks:**

- Emission Level(dBuV/m) = Raw Value(dBuV) + Correction Factor(dB/m)
- Correction Factor(dB/m) = Antenna Factor(dB/m) + Cable Factor(dB) – Pre-Amplifier Factor(dB) + Distance Factor
- Margin value = Emission Level – Limit value
- The other emission levels were very low against the limit.
- The test distance for below 0.49 MHz is 3 m, extrapolate the measured field strength to a distance of 300 meters.  
Distance factor@3m =  $40 \cdot \log(3/300) = -80\text{dB}$
- \* \*: Fundamental frequency.
- Loop antenna was used for all radiated emission below 30MHz.

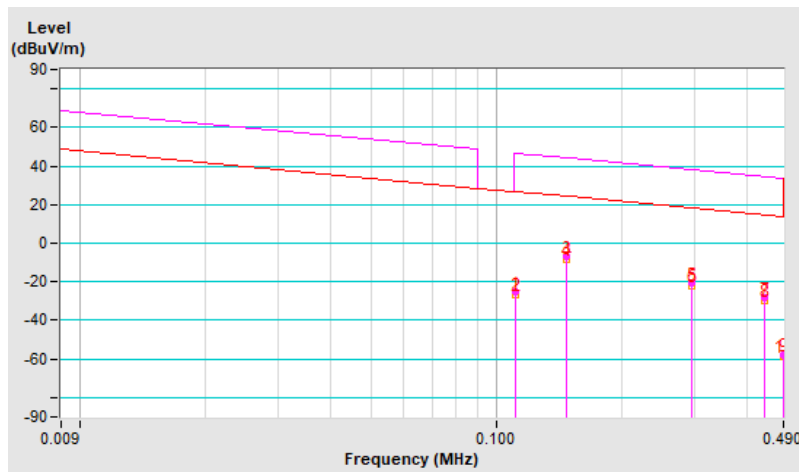

Test Frequency	147.2kHz	Detector Function	Peak (PK)
Frequency Range	9 kHz ~ 490 kHz		Average (AV)

Antenna Polarity : Perpendicular								
No	Frequency (MHz)	Emission Level (dBuV/m)	Limit (dBuV/m)	Margin (dB)	Antenna Height (m)	Table Angle (Degree)	Raw Value (dBuV)	Correction Factor (dB/m)
1	0.1110	-25.1 PK	46.7	-71.8	1.00	168	34.5	-59.6
2	0.1110	-26.2 AV	26.7	-52.9	1.00	168	33.4	-59.6
3	*0.1472	-16.6 PK	44.2	-60.8	1.00	274	44.5	-61.1
4	*0.1472	-17.8 AV	24.2	-42.0	1.00	274	43.3	-61.1
5	0.2944	-23.9 PK	38.2	-62.1	1.00	167	42.9	-66.8
6	0.2944	-24.9 AV	18.2	-43.1	1.00	167	41.9	-66.8
7	0.4416	-31.4 PK	34.7	-66.1	1.00	315	38.1	-69.5
8	0.4416	-32.5 AV	14.7	-47.2	1.00	315	37.0	-69.5
9	0.4890	-54.1 PK	33.8	-87.9	1.00	26	16.2	-70.3
10	0.4890	-55.7 AV	13.8	-69.5	1.00	26	14.6	-70.3

**Remarks:**

1. Emission Level(dBuV/m) = Raw Value(dBuV) + Correction Factor(dB/m)
2. Correction Factor(dB/m) = Antenna Factor(dB/m) + Cable Factor(dB) – Pre-Amplifier Factor(dB) + Distance Factor
3. Margin value = Emission Level – Limit value
4. The other emission levels were very low against the limit.
5. The test distance for below 0.49 MHz is 3 m, extrapolate the measured field strength to a distance of 300 meters.  
Distance factor@3m =  $40 \cdot \log(3/300) = -80\text{dB}$
6. “ \* “: Fundamental frequency.
7. Loop antenna was used for all radiated emission below 30MHz.

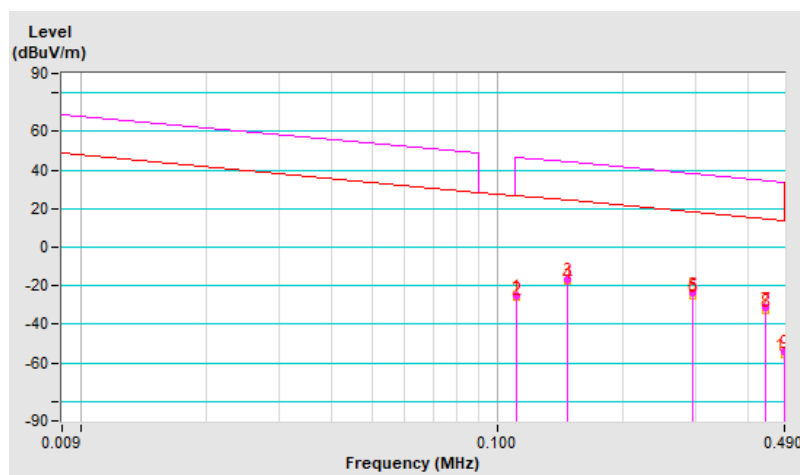

Test Frequency	147.2kHz	Detector Function	Peak (PK)
Frequency Range	9 kHz ~ 490 kHz		Average (AV)

Antenna Polarity : Ground-parallel								
No	Frequency (MHz)	Emission Level (dBuV/m)	Limit (dBuV/m)	Margin (dB)	Antenna Height (m)	Table Angle (Degree)	Raw Value (dBuV)	Correction Factor (dB/m)
1	0.1110	-26.7 PK	46.7	-73.4	1.00	133	32.9	-59.6
2	0.1110	-27.8 AV	26.7	-54.5	1.00	133	31.8	-59.6
3	*0.1472	-7.9 PK	44.2	-52.1	1.00	35	53.2	-61.1
4	*0.1472	-8.8 AV	24.2	-33.0	1.00	35	52.3	-61.1
5	0.2944	-23.6 PK	38.2	-61.8	1.00	157	43.2	-66.8
6	0.2944	-24.7 AV	18.2	-42.9	1.00	157	42.1	-66.8
7	0.4416	-28.3 PK	34.7	-63.0	1.00	213	41.2	-69.5
8	0.4416	-29.4 AV	14.7	-44.1	1.00	213	40.1	-69.5
9	0.4890	-54.7 PK	33.8	-88.5	1.00	222	15.6	-70.3
10	0.4890	-55.9 AV	13.8	-69.7	1.00	222	14.4	-70.3

**Remarks:**

1. Emission Level(dBuV/m) = Raw Value(dBuV) + Correction Factor(dB/m)
2. Correction Factor(dB/m) = Antenna Factor(dB/m) + Cable Factor(dB) – Pre-Amplifier Factor(dB) + Distance Factor
3. Margin value = Emission Level – Limit value
4. The other emission levels were very low against the limit.
5. The test distance for below 0.49 MHz is 3 m, extrapolate the measured field strength to a distance of 300 meters.  
Distance factor@3m =  $40 \cdot \log(3/300) = -80\text{dB}$
6. “ \* “: Fundamental frequency.
7. Loop antenna was used for all radiated emission below 30MHz.

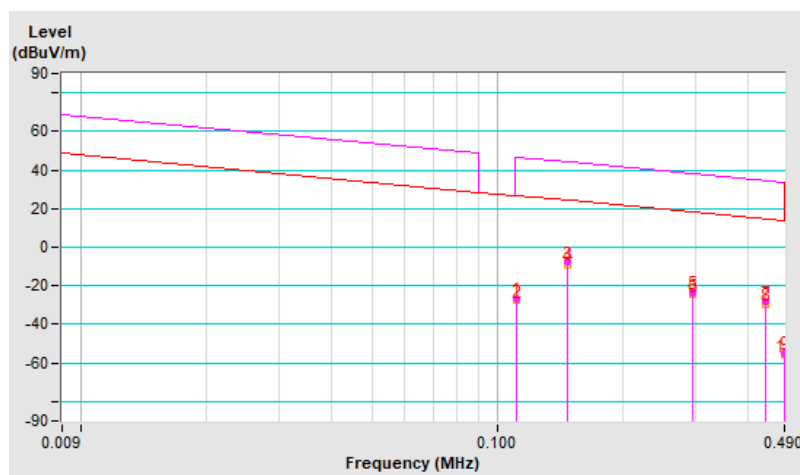

<b>Test Frequency</b>	147.2kHz	<b>Detector Function</b>	Quasi-Peak (QP)
<b>Frequency Range</b>	490 kHz ~ 30 MHz		

Antenna Polarity : Parallel								
No	Frequency (MHz)	Emission Level (dBuV/m)	Limit (dBuV/m)	Margin (dB)	Antenna Height (m)	Table Angle (Degree)	Raw Value (dBuV)	Correction Factor (dB/m)
1	0.5888	7.3 QP	32.2	-24.9	1.00	120	38.5	-31.2

**Remarks:**

1. Emission Level(dBuV/m) = Raw Value(dBuV) + Correction Factor(dB/m)
2. Correction Factor(dB/m) = Antenna Factor(dB/m) + Cable Factor(dB) – Pre-Amplifier Factor(dB) + Distance Factor
3. Margin value = Emission Level – Limit value
4. The other emission levels were very low against the limit.
5. The test distance for 0.49 ~ 30 MHz is 3 m, extrapolate the measured field strength to a distance of 30 meters.  
Distance factor@3m =  $40 \cdot \log(3/30) = -40\text{dB}$
6. Loop antenna was used for all radiated emission below 30MHz.

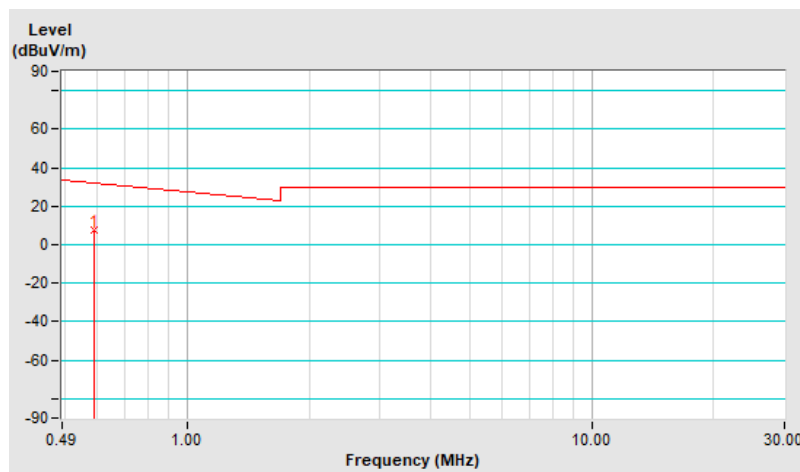

<b>Test Frequency</b>	147.2kHz	<b>Detector Function</b>	Quasi-Peak (QP)
<b>Frequency Range</b>	490 kHz ~ 30 MHz		

Antenna Polarity : Perpendicular								
No	Frequency (MHz)	Emission Level (dBuV/m)	Limit (dBuV/m)	Margin (dB)	Antenna Height (m)	Table Angle (Degree)	Raw Value (dBuV)	Correction Factor (dB/m)
1	0.5888	2.6 QP	32.2	-29.6	1.00	238	33.8	-31.2

**Remarks:**

1. Emission Level(dBuV/m) = Raw Value(dBuV) + Correction Factor(dB/m)
2. Correction Factor(dB/m) = Antenna Factor(dB/m) + Cable Factor(dB) – Pre-Amplifier Factor(dB) + Distance Factor
3. Margin value = Emission Level – Limit value
4. The other emission levels were very low against the limit.
5. The test distance for 0.49 ~ 30 MHz is 3 m, extrapolate the measured field strength to a distance of 30 meters.  
Distance factor@3m =  $40 \cdot \log(3/30) = -40\text{dB}$
6. Loop antenna was used for all radiated emission below 30MHz.

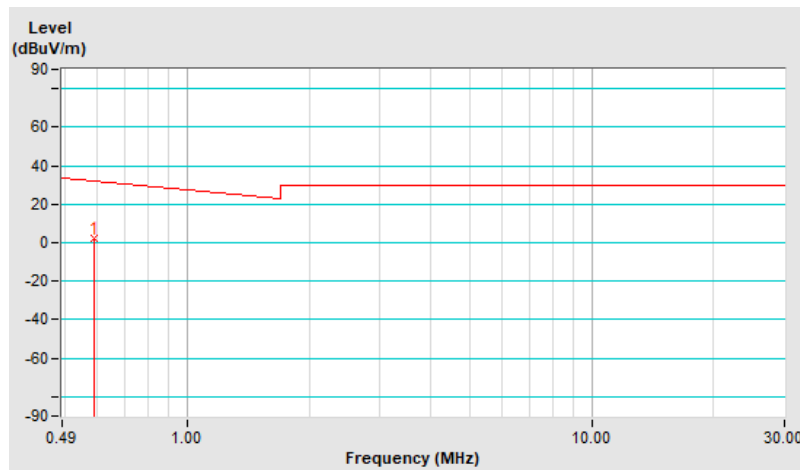

<b>Test Frequency</b>	147.2kHz	<b>Detector Function</b>	Quasi-Peak (QP)
<b>Frequency Range</b>	490 kHz ~ 30 MHz		

Antenna Polarity : Ground-parallel								
No	Frequency (MHz)	Emission Level (dBuV/m)	Limit (dBuV/m)	Margin (dB)	Antenna Height (m)	Table Angle (Degree)	Raw Value (dBuV)	Correction Factor (dB/m)
1	0.5888	4.1 QP	32.2	-28.1	1.00	237	35.3	-31.2

**Remarks:**

1. Emission Level(dBuV/m) = Raw Value(dBuV) + Correction Factor(dB/m)
2. Correction Factor(dB/m) = Antenna Factor(dB/m) + Cable Factor(dB) – Pre-Amplifier Factor(dB) + Distance Factor
3. Margin value = Emission Level – Limit value
4. The other emission levels were very low against the limit.
5. The test distance for 0.49 ~ 30 MHz is 3 m, extrapolate the measured field strength to a distance of 30 meters.  
Distance factor@3m =  $40 \cdot \log(3/30) = -40\text{dB}$
6. Loop antenna was used for all radiated emission below 30MHz.

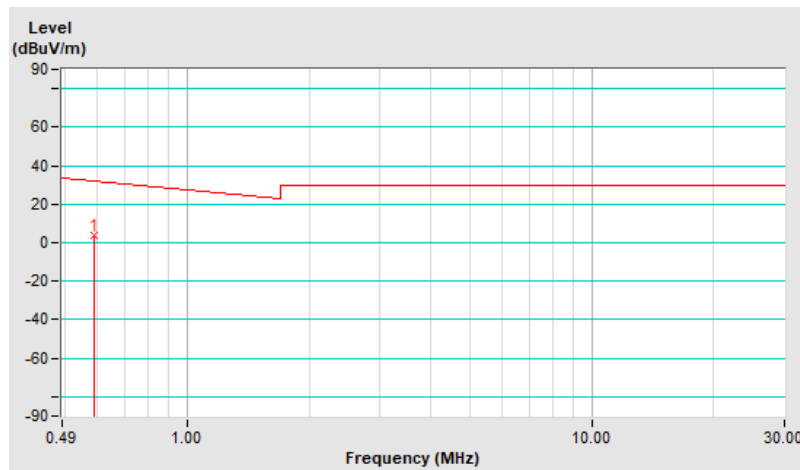

Mode B

<b>Test Frequency</b>	127.8kHz	<b>Detector Function</b>	Peak (PK)
<b>Frequency Range</b>	9 kHz ~ 490 kHz		Average (AV)

Antenna Polarity : Parallel								
No	Frequency (MHz)	Emission Level (dBuV/m)	Limit (dBuV/m)	Margin (dB)	Antenna Height (m)	Table Angle (Degree)	Raw Value (dBuV)	Correction Factor (dB/m)
1	0.1110	-25.5 PK	46.7	-72.2	1.00	247	34.1	-59.6
2	0.1110	-26.7 AV	26.7	-53.4	1.00	247	32.9	-59.6
3	*0.1278	-3.6 PK	45.5	-49.1	1.00	172	56.7	-60.3
4	*0.1278	-4.8 AV	25.5	-30.3	1.00	172	55.5	-60.3
5	0.2556	-17.1 PK	39.5	-56.6	1.00	219	48.1	-65.2
6	0.2556	-18.2 AV	19.5	-37.7	1.00	219	47.0	-65.2
7	0.3834	-27.1 PK	35.9	-63.0	1.00	148	41.4	-68.5
8	0.3834	-28.2 AV	15.9	-44.1	1.00	148	40.3	-68.5
9	0.4890	-57.1 PK	33.8	-90.9	1.00	189	13.2	-70.3
10	0.4890	-58.2 AV	13.8	-72.0	1.00	189	12.1	-70.3

**Remarks:**

1. Emission Level(dBuV/m) = Raw Value(dBuV) + Correction Factor(dB/m)
2. Correction Factor(dB/m) = Antenna Factor(dB/m) + Cable Factor(dB) – Pre-Amplifier Factor(dB) + Distance Factor
3. Margin value = Emission Level – Limit value
4. The other emission levels were very low against the limit.
5. The test distance for below 0.49 MHz is 3 m, extrapolate the measured field strength to a distance of 300 meters.  
Distance factor@3m =  $40 \cdot \log(3/300) = -80\text{dB}$
6. “ \* “: Fundamental frequency.
7. Loop antenna was used for all radiated emission below 30MHz.

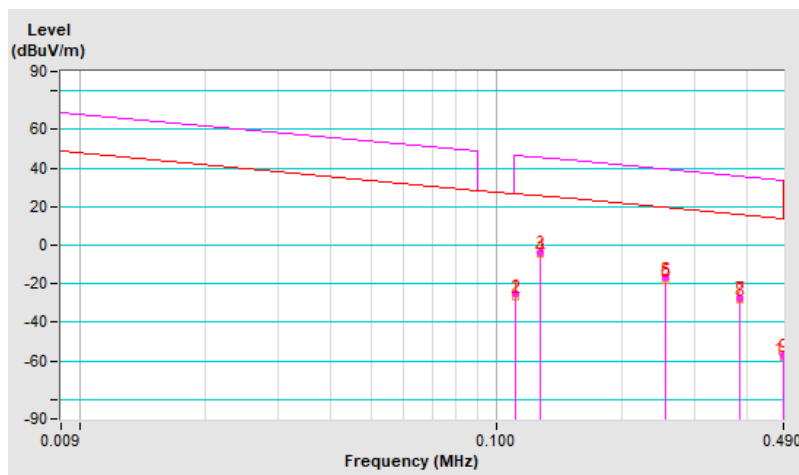



Test Frequency	127.8kHz	Detector Function	Peak (PK)
Frequency Range	9 kHz ~ 490 kHz		Average (AV)

Antenna Polarity : Perpendicular								
No	Frequency (MHz)	Emission Level (dBuV/m)	Limit (dBuV/m)	Margin (dB)	Antenna Height (m)	Table Angle (Degree)	Raw Value (dBuV)	Correction Factor (dB/m)
1	0.1110	-25.3 PK	46.7	-72.0	1.00	177	34.3	-59.6
2	0.1110	-26.4 AV	26.7	-53.1	1.00	177	33.2	-59.6
3	*0.1278	-14.8 PK	45.5	-60.3	1.00	207	45.5	-60.3
4	*0.1278	-15.9 AV	25.5	-41.4	1.00	207	44.4	-60.3
5	0.2556	-23.5 PK	39.5	-63.0	1.00	311	41.7	-65.2
6	0.2556	-24.6 AV	19.5	-44.1	1.00	311	40.6	-65.2
7	0.3834	-31.1 PK	35.9	-67.0	1.00	218	37.4	-68.5
8	0.3834	-32.2 AV	15.9	-48.1	1.00	218	36.3	-68.5
9	0.4890	-54.2 PK	33.8	-88.0	1.00	33	16.1	-70.3
10	0.4890	-55.3 AV	13.8	-69.1	1.00	33	15.0	-70.3

**Remarks:**

- Emission Level(dBuV/m) = Raw Value(dBuV) + Correction Factor(dB/m)
- Correction Factor(dB/m) = Antenna Factor(dB/m) + Cable Factor(dB) – Pre-Amplifier Factor(dB) + Distance Factor
- Margin value = Emission Level – Limit value
- The other emission levels were very low against the limit.
- The test distance for below 0.49 MHz is 3 m, extrapolate the measured field strength to a distance of 300 meters.  
Distance factor@3m =  $40 \cdot \log(3/300) = -80\text{dB}$
- \* \* \*: Fundamental frequency.
- Loop antenna was used for all radiated emission below 30MHz.

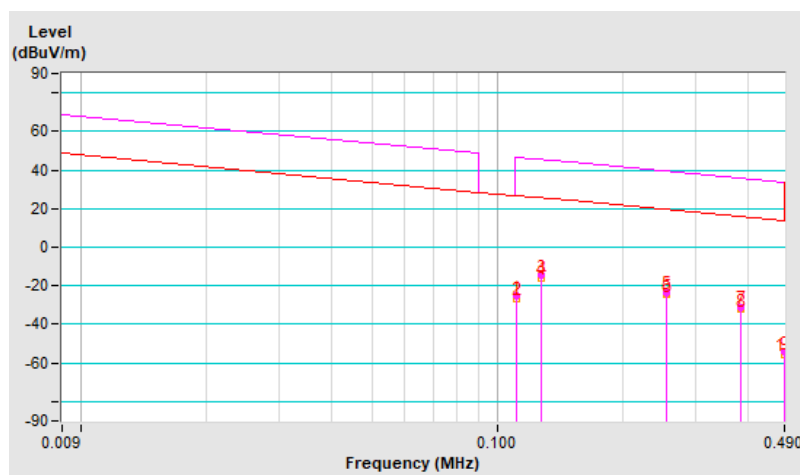

Test Frequency	127.8kHz	Detector Function	Peak (PK)
Frequency Range	9 kHz ~ 490 kHz		Average (AV)

Antenna Polarity : Ground-parallel								
No	Frequency (MHz)	Emission Level (dBuV/m)	Limit (dBuV/m)	Margin (dB)	Antenna Height (m)	Table Angle (Degree)	Raw Value (dBuV)	Correction Factor (dB/m)
1	0.1110	-25.6 PK	46.7	-72.3	1.00	157	34.0	-59.6
2	0.1110	-27.7 AV	26.7	-54.4	1.00	157	31.9	-59.6
3	*0.1278	-4.7 PK	45.5	-50.2	1.00	236	55.6	-60.3
4	*0.1278	-5.8 AV	25.5	-31.3	1.00	236	54.5	-60.3
5	0.2556	-17.9 PK	39.5	-57.4	1.00	133	47.3	-65.2
6	0.2556	-18.9 AV	19.5	-38.4	1.00	133	46.3	-65.2
7	0.3834	-27.7 PK	35.9	-63.6	1.00	218	40.8	-68.5
8	0.3834	-28.7 AV	15.9	-44.6	1.00	218	39.8	-68.5
9	0.4890	-54.8 PK	33.8	-88.6	1.00	313	15.5	-70.3
10	0.4890	-55.9 AV	13.8	-69.7	1.00	313	14.4	-70.3

**Remarks:**

- Emission Level(dBuV/m) = Raw Value(dBuV) + Correction Factor(dB/m)
- Correction Factor(dB/m) = Antenna Factor(dB/m) + Cable Factor(dB) – Pre-Amplifier Factor(dB) + Distance Factor
- Margin value = Emission Level – Limit value
- The other emission levels were very low against the limit.
- The test distance for below 0.49 MHz is 3 m, extrapolate the measured field strength to a distance of 300 meters.  
Distance factor@3m =  $40 \cdot \log(3/300) = -80\text{dB}$
- \* \* \*: Fundamental frequency.
- Loop antenna was used for all radiated emission below 30MHz.

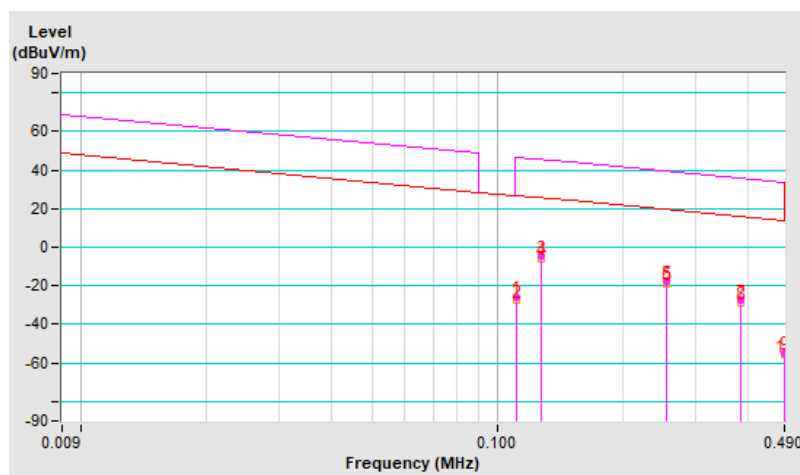

<b>Test Frequency</b>	127.8kHz	<b>Detector Function</b>	Quasi-Peak (QP)
<b>Frequency Range</b>	490 kHz ~ 30 MHz		

Antenna Polarity : Parallel								
No	Frequency (MHz)	Emission Level (dBuV/m)	Limit (dBuV/m)	Margin (dB)	Antenna Height (m)	Table Angle (Degree)	Raw Value (dBuV)	Correction Factor (dB/m)
1	0.6390	1.8 QP	31.5	-29.7	1.00	208	33.4	-31.6

**Remarks:**

1. Emission Level(dBuV/m) = Raw Value(dBuV) + Correction Factor(dB/m)
2. Correction Factor(dB/m) = Antenna Factor(dB/m) + Cable Factor(dB) – Pre-Amplifier Factor(dB) + Distance Factor
3. Margin value = Emission Level – Limit value
4. The other emission levels were very low against the limit.
5. The test distance for 0.49 ~ 30 MHz is 3 m, extrapolate the measured field strength to a distance of 30 meters.  
Distance factor@3m =  $40 \cdot \log(3/30) = -40\text{dB}$
6. Loop antenna was used for all radiated emission below 30MHz.

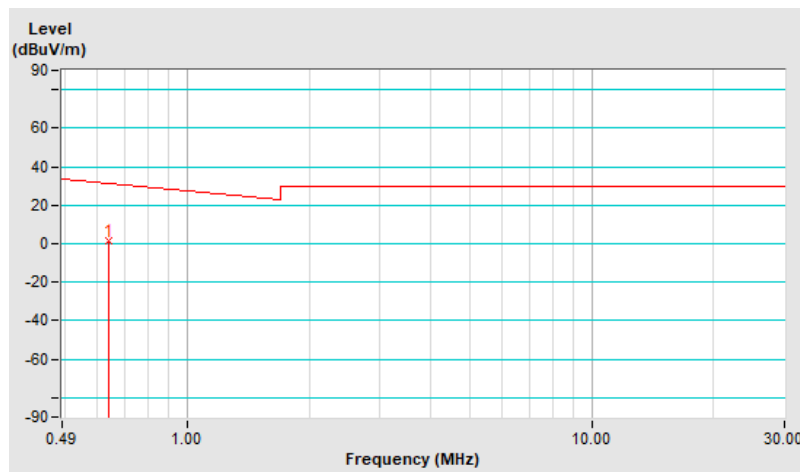

<b>Test Frequency</b>	127.8kHz	<b>Detector Function</b>	Quasi-Peak (QP)
<b>Frequency Range</b>	490 kHz ~ 30 MHz		

Antenna Polarity : Perpendicular								
No	Frequency (MHz)	Emission Level (dBuV/m)	Limit (dBuV/m)	Margin (dB)	Antenna Height (m)	Table Angle (Degree)	Raw Value (dBuV)	Correction Factor (dB/m)
1	0.6390	-1.5 QP	31.5	-33.0	1.00	140	30.1	-31.6

**Remarks:**

1. Emission Level(dBuV/m) = Raw Value(dBuV) + Correction Factor(dB/m)
2. Correction Factor(dB/m) = Antenna Factor(dB/m) + Cable Factor(dB) – Pre-Amplifier Factor(dB) + Distance Factor
3. Margin value = Emission Level – Limit value
4. The other emission levels were very low against the limit.
5. The test distance for 0.49 ~ 30 MHz is 3 m, extrapolate the measured field strength to a distance of 30 meters.  
Distance factor@3m =  $40 \cdot \log(3/30) = -40\text{dB}$
6. Loop antenna was used for all radiated emission below 30MHz.

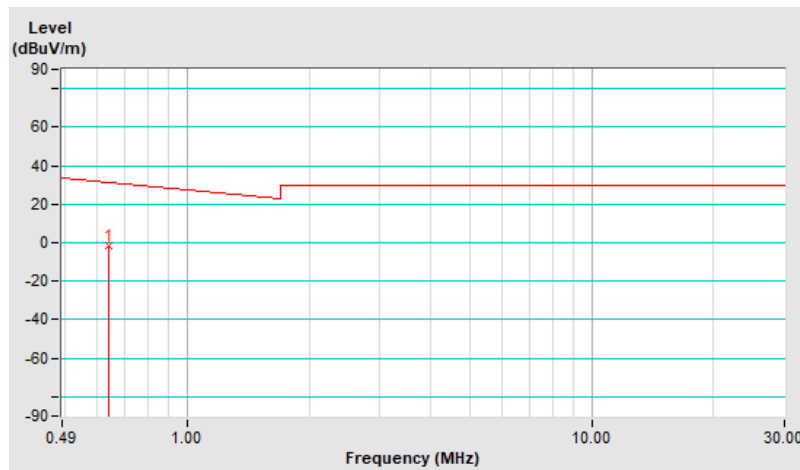

<b>Test Frequency</b>	127.8kHz	<b>Detector Function</b>	Quasi-Peak (QP)
<b>Frequency Range</b>	490 kHz ~ 30 MHz		

Antenna Polarity : Ground-parallel								
No	Frequency (MHz)	Emission Level (dBuV/m)	Limit (dBuV/m)	Margin (dB)	Antenna Height (m)	Table Angle (Degree)	Raw Value (dBuV)	Correction Factor (dB/m)
1	0.6390	2.1 QP	31.5	-29.4	1.00	311	33.7	-31.6

**Remarks:**

1. Emission Level(dBuV/m) = Raw Value(dBuV) + Correction Factor(dB/m)
2. Correction Factor(dB/m) = Antenna Factor(dB/m) + Cable Factor(dB) – Pre-Amplifier Factor(dB) + Distance Factor
3. Margin value = Emission Level – Limit value
4. The other emission levels were very low against the limit.
5. The test distance for 0.49 ~ 30 MHz is 3 m, extrapolate the measured field strength to a distance of 30 meters.  
Distance factor@3m =  $40 \cdot \log(3/30) = -40\text{dB}$
6. Loop antenna was used for all radiated emission below 30MHz.

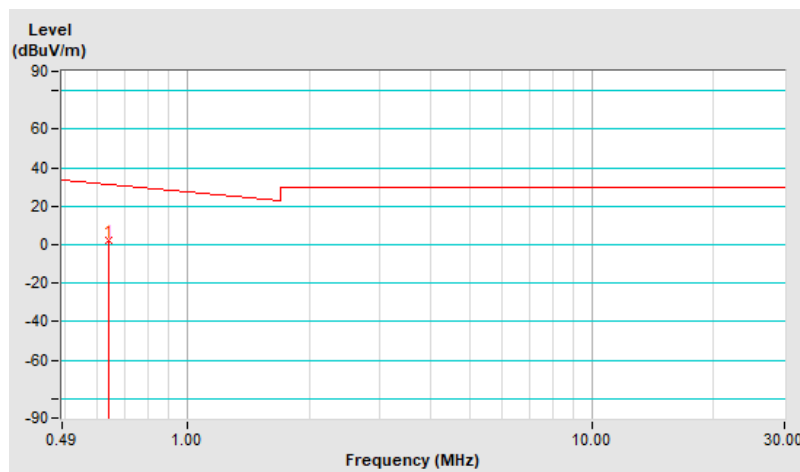

Above 30MHz Data:

Mode A

<b>Test Frequency</b>	147.2kHz	<b>Detector Function</b>	Quasi-Peak (QP)
<b>Frequency Range</b>	30MHz ~ 1GHz		

Antenna Polarity & Test Distance : Horizontal at 3 m								
No	Frequency (MHz)	Emission Level (dBuV/m)	Limit (dBuV/m)	Margin (dB)	Antenna Height (m)	Table Angle (Degree)	Raw Value (dBuV)	Correction Factor (dB/m)
1	40.43	30.6 QP	40.0	-9.4	1.23 H	144	39.9	-9.3
2	70.45	36.1 QP	40.0	-3.9	1.36 H	237	47.0	-10.9
3	190.24	34.2 QP	43.5	-9.3	1.48 H	320	44.7	-10.5
4	296.07	33.9 QP	46.0	-12.1	1.69 H	142	40.2	-6.3
5	465.53	33.5 QP	46.0	-12.5	2.50 H	142	36.0	-2.5
6	591.97	36.4 QP	46.0	-9.6	1.42 H	0	35.9	0.5

Remarks:

1. Emission Level(dBuV/m) = Raw Value(dBuV) + Correction Factor(dB/m)
2. Correction Factor(dB/m) = Antenna Factor (dB/m) + Cable Factor (dB) – Pre-Amplifier Factor (dB)
3. Margin value = Emission level – Limit value
4. The other emission levels were very low against the limit.

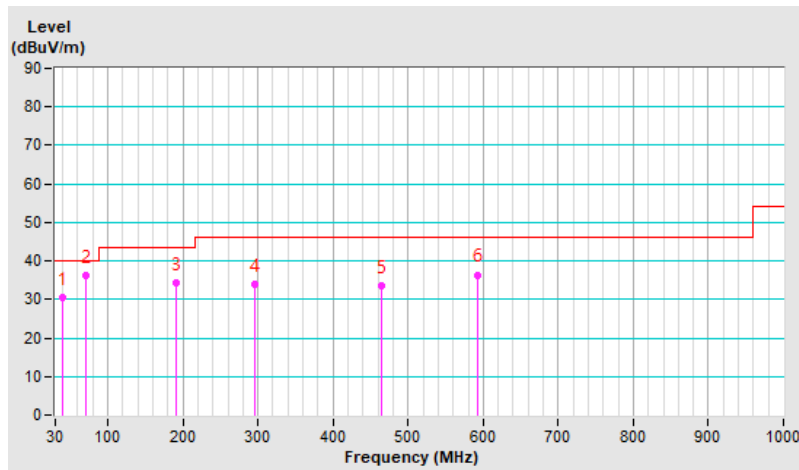

Test Frequency	147.2kHz	Detector Function	Quasi-Peak (QP)
Frequency Range	30MHz ~ 1GHz		

Antenna Polarity & Test Distance : Vertical at 3 m								
No	Frequency (MHz)	Emission Level (dBuV/m)	Limit (dBuV/m)	Margin (dB)	Antenna Height (m)	Table Angle (Degree)	Raw Value (dBuV)	Correction Factor (dB/m)
1	42.17	37.3 QP	40.0	-2.7	1.06 V	125	46.3	-9.0
2	69.62	36.7 QP	40.0	-3.3	1.13 V	20	47.4	-10.7
3	126.81	36.8 QP	43.5	-6.7	1.24 V	137	46.9	-10.1
4	154.60	30.5 QP	43.5	-13.0	1.36 V	111	38.6	-8.1
5	424.84	34.1 QP	46.0	-11.9	1.69 V	180	37.3	-3.2
6	561.95	32.8 QP	46.0	-13.2	2.01 V	20	33.3	-0.5

**Remarks:**

1. Emission Level(dBuV/m) = Raw Value(dBuV) + Correction Factor(dB/m)
2. Correction Factor(dB/m) = Antenna Factor (dB/m) + Cable Factor (dB)  
– Pre-Amplifier Factor (dB)
3. Margin value = Emission level – Limit value
4. The other emission levels were very low against the limit.

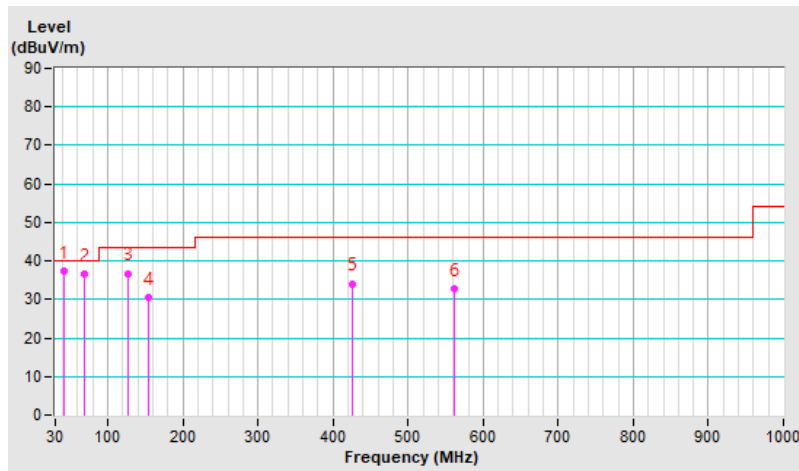

Mode B

<b>Test Frequency</b>	127.8kHz	<b>Detector Function</b>	Quasi-Peak (QP)
<b>Frequency Range</b>	30MHz ~ 1GHz		

**Antenna Polarity & Test Distance : Horizontal at 3 m**

No	Frequency (MHz)	Emission Level (dBuV/m)	Limit (dBuV/m)	Margin (dB)	Antenna Height (m)	Table Angle (Degree)	Raw Value (dBuV)	Correction Factor (dB/m)
1	38.68	28.1 QP	40.0	-11.9	1.51 H	49	37.7	-9.6
2	70.45	29.3 QP	40.0	-10.7	1.23 H	283	40.2	-10.9
3	185.64	28.6 QP	43.5	-14.9	1.45 H	223	38.7	-10.1
4	262.36	32.6 QP	46.0	-13.4	2.12 H	167	40.1	-7.5
5	306.64	30.8 QP	46.0	-15.2	1.11 H	148	36.7	-5.9
6	424.94	33.7 QP	46.0	-12.3	1.56 H	254	36.9	-3.2

**Remarks:**

1. Emission Level(dBuV/m) = Raw Value(dBuV) + Correction Factor(dB/m)
2. Correction Factor(dB/m) = Antenna Factor (dB/m) + Cable Factor (dB)  
– Pre-Amplifier Factor (dB)
3. Margin value = Emission level – Limit value
4. The other emission levels were very low against the limit.

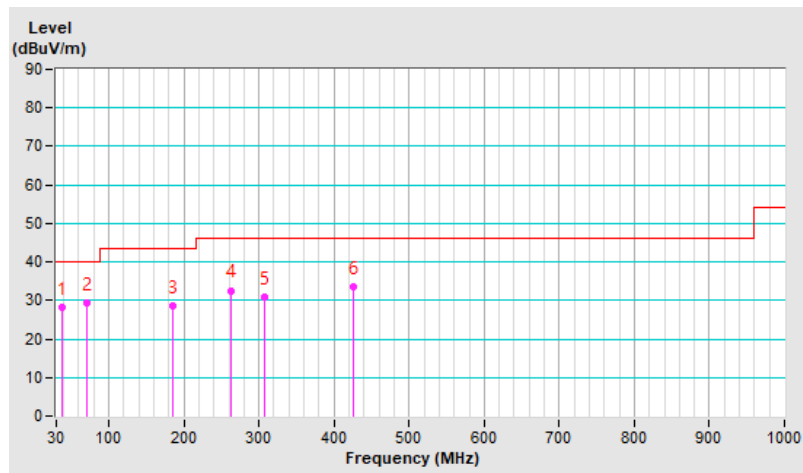



Test Frequency	127.8kHz	Detector Function	Quasi-Peak (QP)
Frequency Range	30MHz ~ 1GHz		

Antenna Polarity & Test Distance : Vertical at 3 m								
No	Frequency (MHz)	Emission Level (dBuV/m)	Limit (dBuV/m)	Margin (dB)	Antenna Height (m)	Table Angle (Degree)	Raw Value (dBuV)	Correction Factor (dB/m)
1	42.42	35.5 QP	40.0	-4.5	1.03 V	124	44.5	-9.0
2	60.94	34.2 QP	40.0	-5.8	1.15 V	360	43.7	-9.5
3	129.18	34.6 QP	43.5	-8.9	1.92 V	146	44.5	-9.9
4	168.42	27.6 QP	43.5	-15.9	2.04 V	115	36.1	-8.5
5	259.36	27.8 QP	46.0	-18.2	2.55 V	182	35.7	-7.9
6	428.19	35.0 QP	46.0	-11.0	1.03 V	163	38.2	-3.2

**Remarks:**

1. Emission Level(dBuV/m) = Raw Value(dBuV) + Correction Factor(dB/m)
2. Correction Factor(dB/m) = Antenna Factor (dB/m) + Cable Factor (dB) – Pre-Amplifier Factor (dB)
3. Margin value = Emission level – Limit value
4. The other emission levels were very low against the limit.

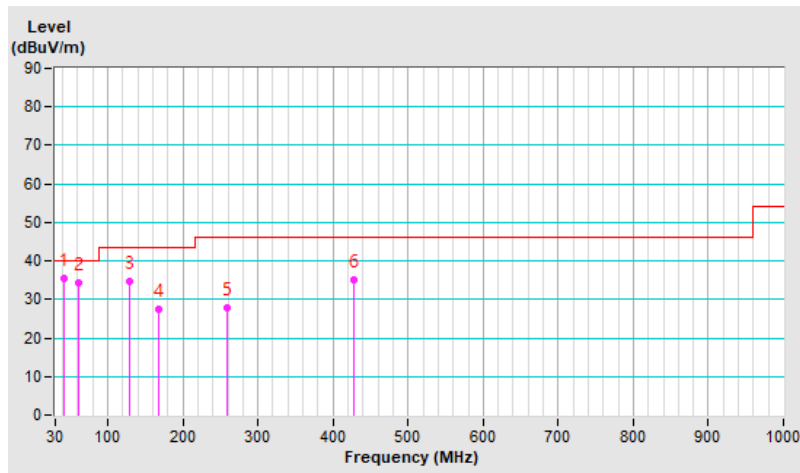

## 4.2 Conducted Emission Measurement

### 4.2.1 Limits of Conducted Emission Measurement

Frequency (MHz)	Conducted Limit (dBuV)	
	Quasi-peak	Average
0.15 - 0.5	66 - 56	56 - 46
0.50 - 5.0	56	46
5.0 - 30.0	60	50

Note: 1. The lower limit shall apply at the transition frequencies.

2. The limit decreases in line with the logarithm of the frequency in the range of 0.15 to 0.50MHz.

### 4.2.2 Test Instruments

Description & Manufacturer	Model no.	Serial No.	Calibrated Date	Calibrated Until
EMI Test Receiver R&S	ESCI	100412	2023/8/23	2024/8/22
EMI Test Receiver R&S	ESCS 30	100276	2023/4/20	2024/4/19
LISN R&S	ENV216	101197	2023/7/12	2024/7/11
LISN Schwarzbeck	NNLK 8121	8121-808	2023/5/2	2024/5/1
LISN Schwarzbeck	NNLK 8121	8121-731	2023/6/9	2024/6/8
LISN Schwarzbeck	NNLK 8129	8129229	2023/6/27	2024/6/26
RF Coaxial Cable PEWC	5D-FB	Cable-CO10-01	2023/2/8	2024/2/7
LISN EMCO	3825/2	9204-1964	2023/8/1	2024/7/31
Fixed Attenuator STI	STI02-2200-10	NO.1	2022/9/14	2023/9/13
50 ohm terminal resistance SUHNER	65BNC-5001	E1-010789	2023/6/16	2024/6/15
50 ohm terminal resistance LYNICS	0900510	E1-011286	2022/9/19	2023/9/18
50 ohm terminal resistance LYNICS	0900510	E1-011285	2022/9/19	2023/9/18
Software BVADT	Cond_V7.3.7.4	NA	NA	NA

Note: 1. The calibration interval of the above test instruments is 12 months and the calibrations are traceable to NML/ROC and NIST/USA.

2. The test was performed in Linkou Conduction 10

3. The VCCI Site Registration No. C-11852.

4. Tested Date: 2023/9/8

#### 4.2.3 Test Procedures

- The EUT was placed 0.4 meters from the conducting wall of the shielded room with EUT being connected to the power mains through a line impedance stabilization network (LISN). Other support units were connected to the power mains through another LISN. The two LISNs provide 50 ohm/ 50uH of coupling impedance for the measuring instrument.
- Both lines of the power mains connected to the EUT were checked for maximum conducted interference.
- The frequency range from 150kHz to 30MHz was searched. Emission levels under (Limit - 20dB) were not recorded.

Note: The resolution bandwidth and video bandwidth of test receiver is 9kHz for quasi-peak detection (QP) and average detection (AV) at frequency 0.15MHz-30MHz.

#### 4.2.4 Deviation from Test Standard

No deviation.

#### 4.2.5 Test Setup

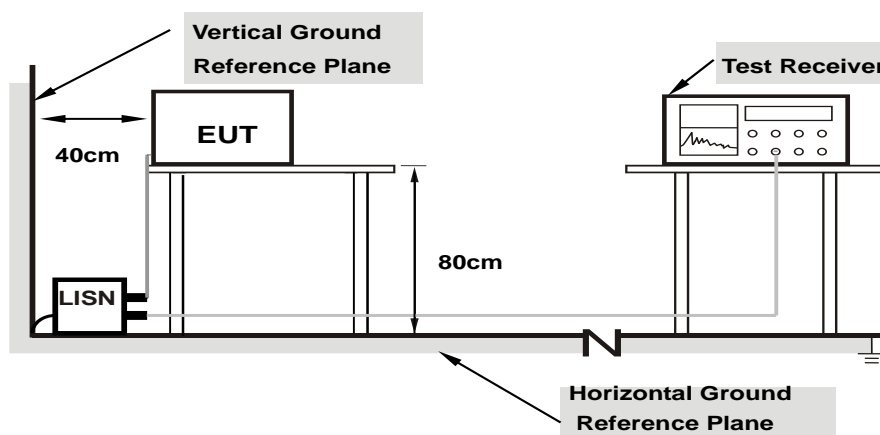

Note: Support units were connected to second LISN.

For the actual test configuration, please refer to the attached file (Test Setup Photo).

#### 4.2.6 EUT Operating Conditions

Same as item 4.1.6.

#### 4.2.7 Test Results

Mode A

<b>Frequency Range</b>	150kHz ~ 30MHz	<b>Detector Function &amp; Resolution Bandwidth</b>	Quasi-Peak (QP) / Average (AV), 9 kHz
------------------------	----------------	---	---------------------------------------

Phase Of Power : Line (L)										
No	Frequency (MHz)	Correction Factor (dB)	Reading Value (dBuV)		Emission Level (dBuV)		Limit (dBuV)		Margin (dB)	
			Q.P.	AV.	Q.P.	AV.	Q.P.	AV.	Q.P.	AV.
1	0.15782	9.60	40.56	34.38	50.16	43.98	65.58	55.58	-15.42	-11.60
2	0.24386	9.64	41.71	28.74	51.35	38.38	61.96	51.96	-10.61	-13.58
3	0.38808	9.65	33.74	20.79	43.39	30.44	58.10	48.10	-14.71	-17.66
4	0.53129	9.65	35.79	26.04	45.44	35.69	56.00	46.00	-10.56	-10.31
5	12.26664	10.10	28.16	10.52	38.26	20.62	60.00	50.00	-21.74	-29.38
6	23.95662	10.33	26.87	21.93	37.20	32.26	60.00	50.00	-22.80	-17.74

**Remarks:**

1. Q.P. and AV. are abbreviations of quasi-peak and average individually.
2. The emission levels of other frequencies were very low against the limit.
3. Margin value = Emission level – Limit value
4. Correction factor = Insertion loss + Cable loss
5. Emission Level = Correction Factor + Reading Value

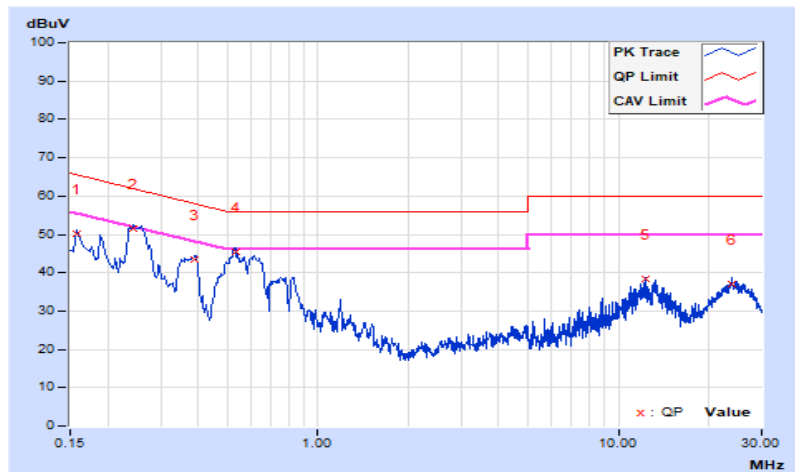

<b>Frequency Range</b>	150kHz ~ 30MHz	<b>Detector Function &amp; Resolution Bandwidth</b>	Quasi-Peak (QP) / Average (AV), 9 kHz
------------------------	----------------	---	---------------------------------------

Phase Of Power : Neutral (N)										
No	Frequency (MHz)	Correction Factor (dB)	Reading Value (dBuV)		Emission Level (dBuV)		Limit (dBuV)		Margin (dB)	
			Q.P.	AV.	Q.P.	AV.	Q.P.	AV.	Q.P.	AV.
1	0.15391	9.65	37.19	30.23	46.84	39.88	65.79	55.79	-18.95	-15.91
2	0.27120	9.64	31.38	26.48	41.02	36.12	61.08	51.08	-20.06	-14.96
3	0.39635	9.56	27.66	23.56	37.22	33.12	57.93	47.93	-20.71	-14.81
<b>4</b>	<b>0.53805</b>	<b>9.58</b>	<b>32.45</b>	<b>28.30</b>	<b>42.03</b>	<b>37.88</b>	<b>56.00</b>	<b>46.00</b>	<b>-13.97</b>	<b>-8.12</b>
5	12.22362	10.12	21.41	13.09	31.53	23.21	60.00	50.00	-28.47	-26.79
6	27.23012	10.41	22.22	17.27	32.63	27.68	60.00	50.00	-27.37	-22.32

**Remarks:**

1. Q.P. and AV. are abbreviations of quasi-peak and average individually.
2. The emission levels of other frequencies were very low against the limit.
3. Margin value = Emission level – Limit value
4. Correction factor = Insertion loss + Cable loss
5. Emission Level = Correction Factor + Reading Value

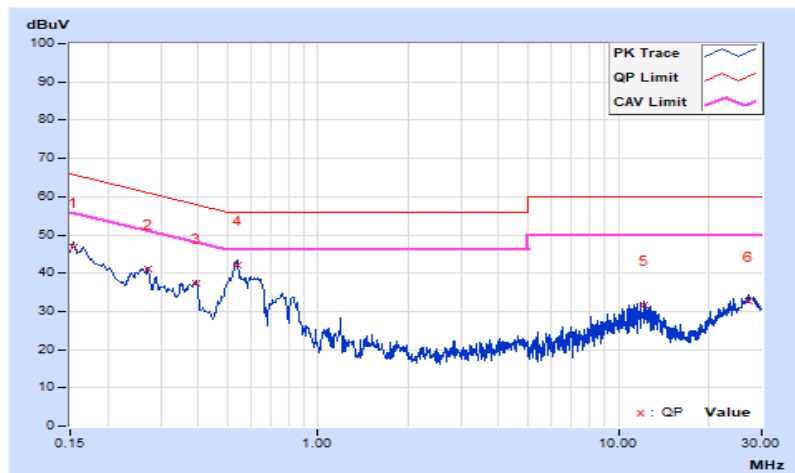

### 4.3 20dB Bandwidth Measurement

#### 4.3.1 Test SetUp

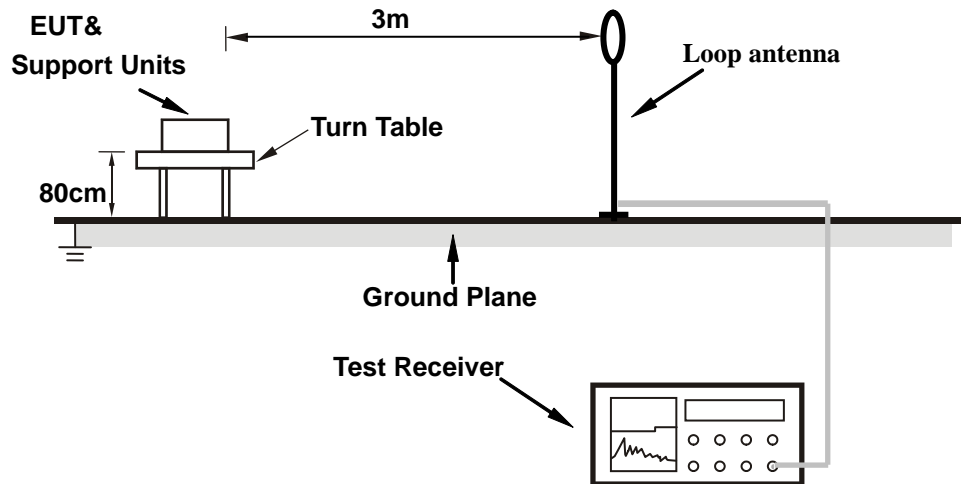

#### 4.3.2 Test Instruments

Refer to section 4.1.2 to get information of above instrument.

#### 4.3.3 Test Procedure

- The EUT was placed on the top of a rotating table 0.8 meters above the ground at a 3 meter Semi-anechoic chamber room. The table was rotated 360 degrees to determine the position of the highest radiation. Then the Loop antenna was rotated 360 degrees to determine the position of the highest radiation.
- The antenna is a broadband loop antenna, which is fixed of a 1m height above the ground, and set away from 3m to the EUT to find the disturbance reading on each frequency.
- The test-receiver system was set to Quasi-peak detect function and specified bandwidth.

#### 4.3.4 Deviation from Test Standard

No deviation.

#### 4.3.5 EUT Operating Conditions

The software provided by client to enable the EUT under transmission condition continuously.

### 4.3.6 Test Results

#### Test Mode A

Frequency (kHz)	20dB Bandwidth (Hz)
147.2	830

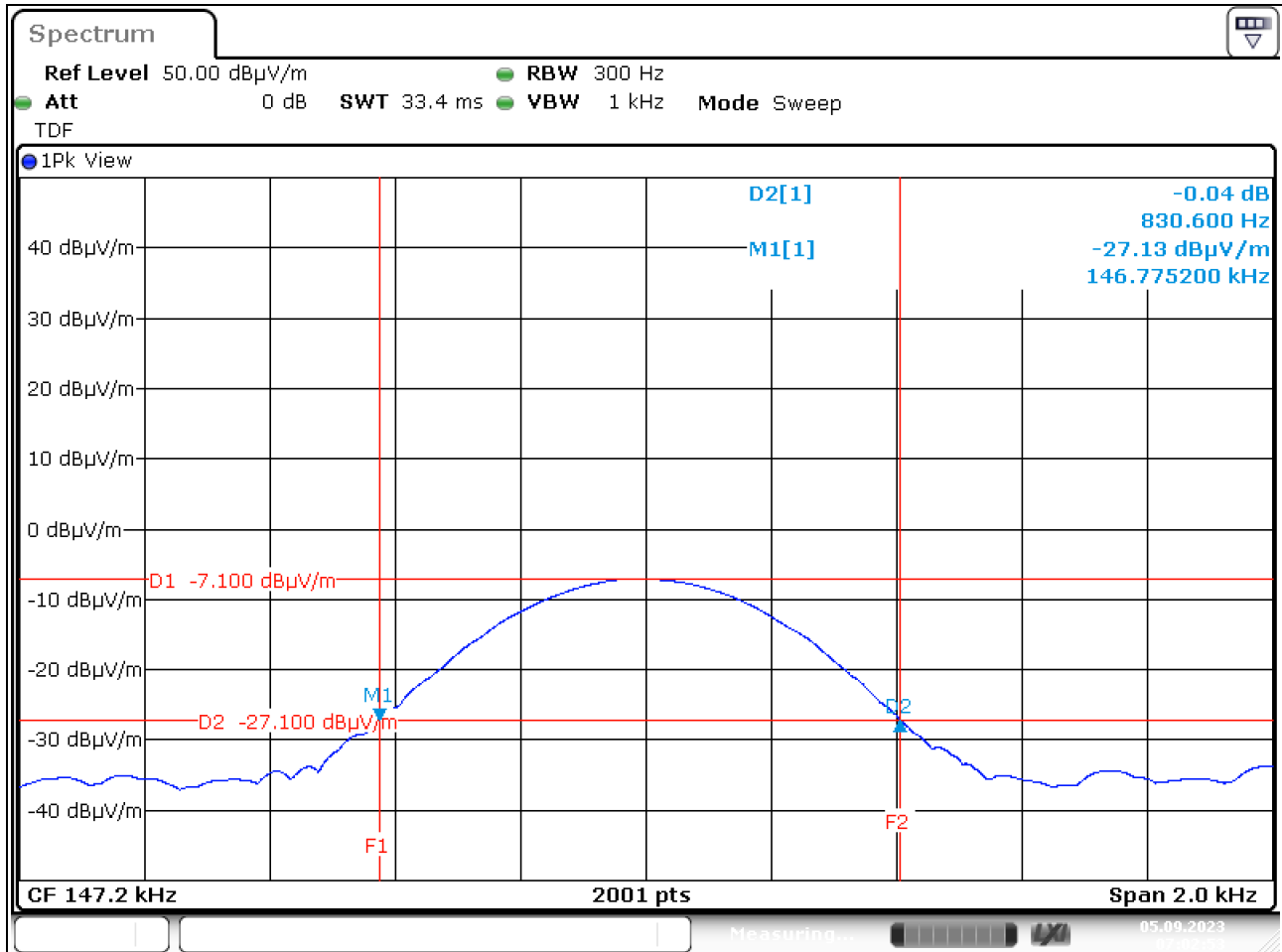

Note: The signal look like CW signal, so RBW can't be match 1~5 % OBW.

Test Mode B

Frequency (kHz)	20dB Bandwidth (Hz)
127.8	808

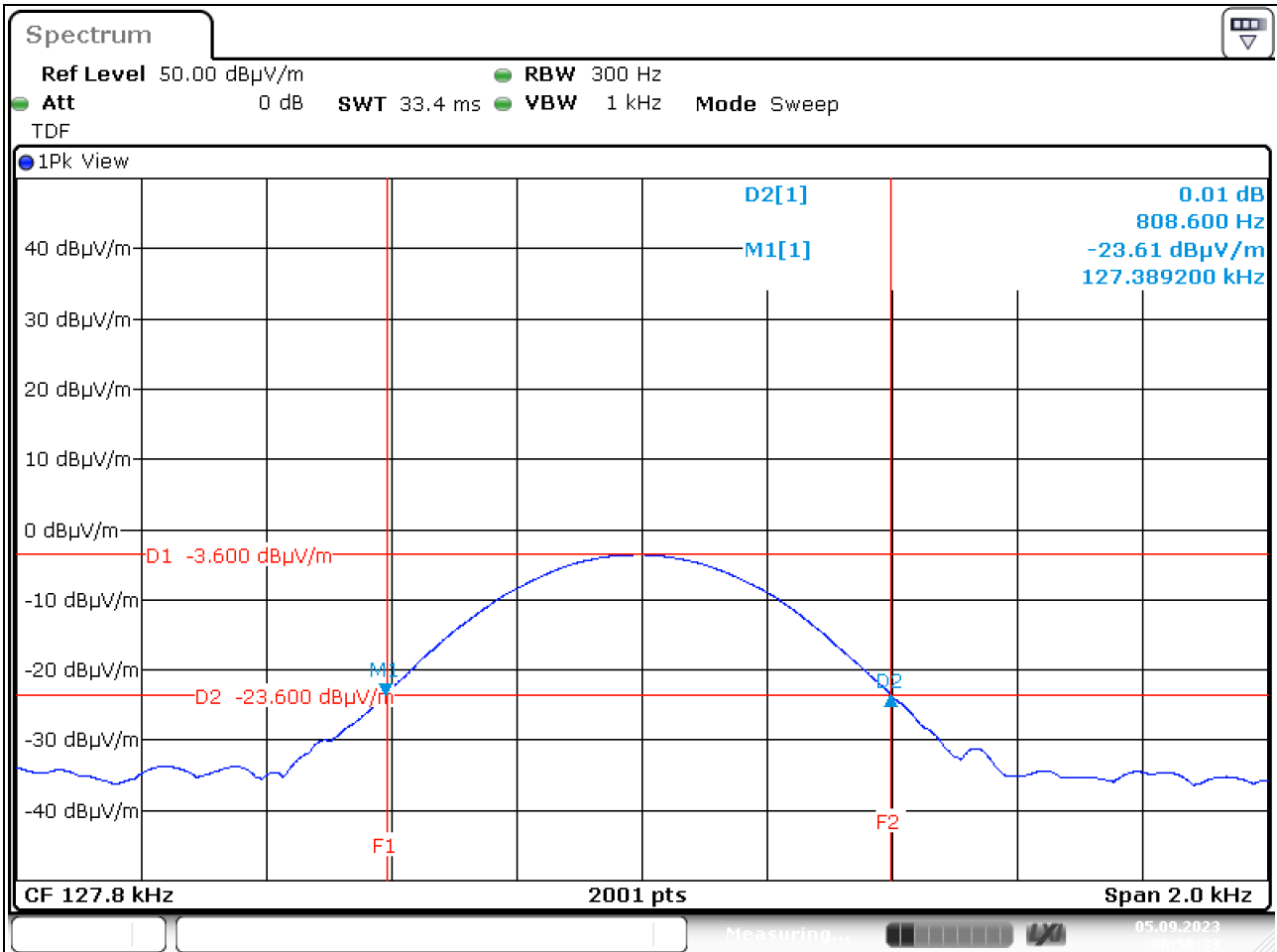

Note: The signal look like CW signal, so RBW can't be match 1~5 % OBW.



## 5 Pictures of Test Arrangements

Please refer to the attached file (Test Setup Photo).

## Appendix – Information of the Testing Laboratories

We, Bureau Veritas Consumer Products Services (H.K.) Ltd., Taoyuan Branch, were founded in 1988 to provide our best service in EMC, Radio, Telecom and Safety consultation. Our laboratories are FCC recognized accredited test firms and accredited and approved according to ISO/IEC 17025.

If you have any comments, please feel free to contact us at the following:

### Lin Kou EMC/RF Lab

Tel: 886-2-26052180

Fax: 886-2-26051924

### Hsin Chu EMC/RF/Telecom Lab

Tel: 886-3-6668565

Fax: 886-3-6668323

### Hwa Ya EMC/RF/Safety Lab

Tel: 886-3-3183232

Fax: 886-3-3270892

**Email:** [service.adt@tw.bureauveritas.com](mailto:service.adt@tw.bureauveritas.com)

**Web Site:** <http://ee.bureauveritas.com.tw>

The address and road map of all our labs can be found in our web site also.

--- END ---