



TESTING LABORATORY
CERTIFICATE#4323.01



FCC PART 15C TEST REPORT

For

ZHEJIANG JIECANG LINEAR MOTION TECHNOLOGY CO., LTD

No.19 XinTao Road, Provincial High Tech Park, XinChang county, ZheJiang Province, 312500
China

FCC ID: 2ANKDJCP35WA-A

Report Type: Original Report	Product Type: Long Distance Wireless Charger
Test Engineer:	CK Huang <i>CK Huang</i>
Report Number:	RSHD201027001-00A
Report Date:	2020-11-12
Reviewed By:	Oscar Ye EMC Manager <i>Oscar Ye</i>
Prepared By:	Bay Area Compliance Laboratories Corp. (Kunshan) No.248 Chenghu Road, Kunshan, Jiangsu province, China Tel: +86-0512-86175000 Fax: +86-0512-88934268 www.baclcorp.com.cn

TABLE OF CONTENTS

GENERAL INFORMATION.....	3
PRODUCT DESCRIPTION FOR EQUIPMENT UNDER TEST (EUT).....	3
OBJECTIVE	3
RELATED SUBMITTAL(S)/GRANT(S).....	3
TEST METHODOLOGY	3
MEASUREMENT UNCERTAINTY	4
TEST FACILITY	4
SYSTEM TEST CONFIGURATION.....	5
DESCRIPTION OF TEST CONFIGURATION	5
EQUIPMENT MODIFICATIONS	5
EUT EXERCISE SOFTWARE	5
SUPPORT EQUIPMENT LIST AND DETAILS	5
EXTERNAL I/O CABLE.....	5
BLOCK DIAGRAM OF TEST SETUP	6
SUMMARY OF TEST RESULTS	7
TEST EQUIPMENT LIST	8
FCC §1.1307& §1.1310& §2.1091 – MAXIMUM PERMISSIBLE EXPOSURE (MPE).....	9
APPLICABLE STANDARD	9
EUT SETUP	10
RESULT	10
TEST DATA	11
FCC §15.203 - ANTENNA REQUIREMENT.....	12
APPLICABLE STANDARD	12
ANTENNA CONNECTOR CONSTRUCTION	12
FCC §15.207 (a) – AC LINE CONDUCTED EMISSIONS	13
APPLICABLE STANDARD	13
EUT SETUP	13
EMI TEST RECEIVER SETUP.....	13
TEST PROCEDURE	13
FACTOR & OVER LIMIT CALCULATION.....	14
TEST RESULTS SUMMARY	14
TEST DATA	14
FCC §15.209 & §15.205 - SPURIOUS EMISSIONS	17
APPLICABLE STANDARD	17
EUT SETUP	17
EMI TEST RECEIVER SETUP.....	17
TEST PROCEDURE	17
CORRECTED AMPLITUDE & MARGIN CALCULATION	18
TEST RESULTS SUMMARY	18
TEST DATA	18

GENERAL INFORMATION

Product Description for Equipment under Test (EUT)

Applicant	ZHEJIANG JIECANG LINEAR MOTION TECHNOLOGY CO., LTD
Tested Model	JCP35WA-A
Product Type	Long Distance Wireless Charger
Power Supply	DC 24V from adapter
RF Function	WPT
Modulation Type	ASK
Operating Band/Frequency	115-130 kHz
Antenna Type	Loop antenna
*Antenna Gain	0.0 dBi

Note: The antenna gain was provided by the applicant.

**All measurement and test data in this report was gathered from production sample serial number: 20201027001. (Assigned by BACL, Kunshan). The EUT was received on 2020-10-27.*

Objective

This report is prepared on behalf of *ZHEJIANG JIECANG LINEAR MOTION TECHNOLOGY CO., LTD* in accordance with Part 2-Subpart J, Part 15-Subparts A and C of the Federal Communication Commissions rules.

The tests were performed in order to determine compliance with FCC Part 15, Subpart C, and section 15.203, 15.205, 15.207 and 15.209 rules.

Related Submittal(s)/Grant(s)

No Related Submittal(s)/Grant(s).

Test Methodology

All measurements contained in this report were conducted with ANSI C63.10-2013, American National Standard of Procedures for Compliance Testing of Unlicensed Wireless Devices.

All emissions measurement was performed at Bay Area Compliance Laboratories Corp. (Kunshan). The radiated testing was performed at an antenna-to-EUT distance of 3 meters.

Measurement Uncertainty

Item		Uncertainty
AC Power Lines Conducted Emissions		3.19dB
Radiated emission	9kHz~30MHz	3.19dB
	30MHz~1GHz	6.11dB
Temperature		1.0°C
Humidity		6%

Test Facility

The test site used by Bay Area Compliance Laboratories Corp. (Kunshan) to collect test data is located on the No.248 Chenghu Road, Kunshan, Jiangsu province, China.

Bay Area Compliance Laboratories Corp. (Kunshan) Lab is accredited to ISO/IEC 17025 by A2LA (Lab code: 4323.01) and the FCC designation No. CN1185 under the FCC KDB 974614 D01 and CAB identifier CN0004 under the ISED requirement. The facility also complies with the radiated and AC line conducted test site criteria set forth in ANSI C63.4-2014.

SYSTEM TEST CONFIGURATION

Description of Test Configuration

The system was configured for testing in a typical fashion (as normally used by a typical user)

Equipment Modifications

No modification was made to the EUT tested.

EUT Exercise Software

No Exercise Software was used.

Support Equipment List and Details

Manufacturer	Description	Model	Serial Number
Apple	Mobile phone	ML7J2CH/A	F4HR2B0TGRYD
/	Load1	/	/
/	Load2	/	/
/	Socket	/	/
GW	Adapter	GW48W-240150CH	/

External I/O Cable

Cable Description	Length (m)	From Port	To
Power Cable	0.3	EUT	Load1
Power Cable	1.0	EUT	Adapter
Power Cable	1.0	Adapter	LISN/AC Source

Block Diagram of Test Setup

For Conducted Emissions:

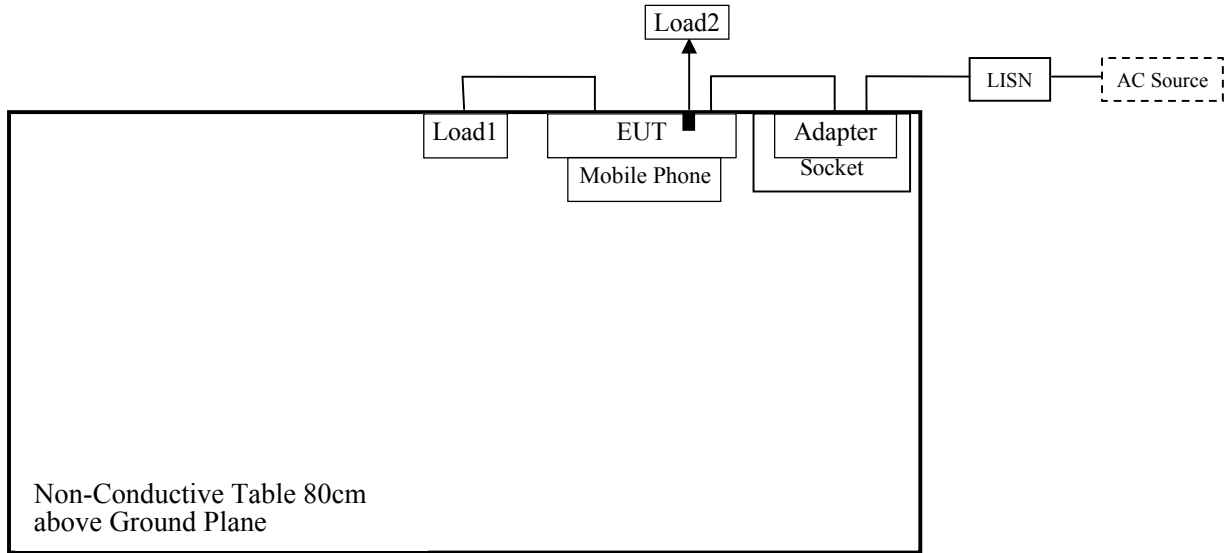

For Radiated Emissions (Below & Above 30MHz):

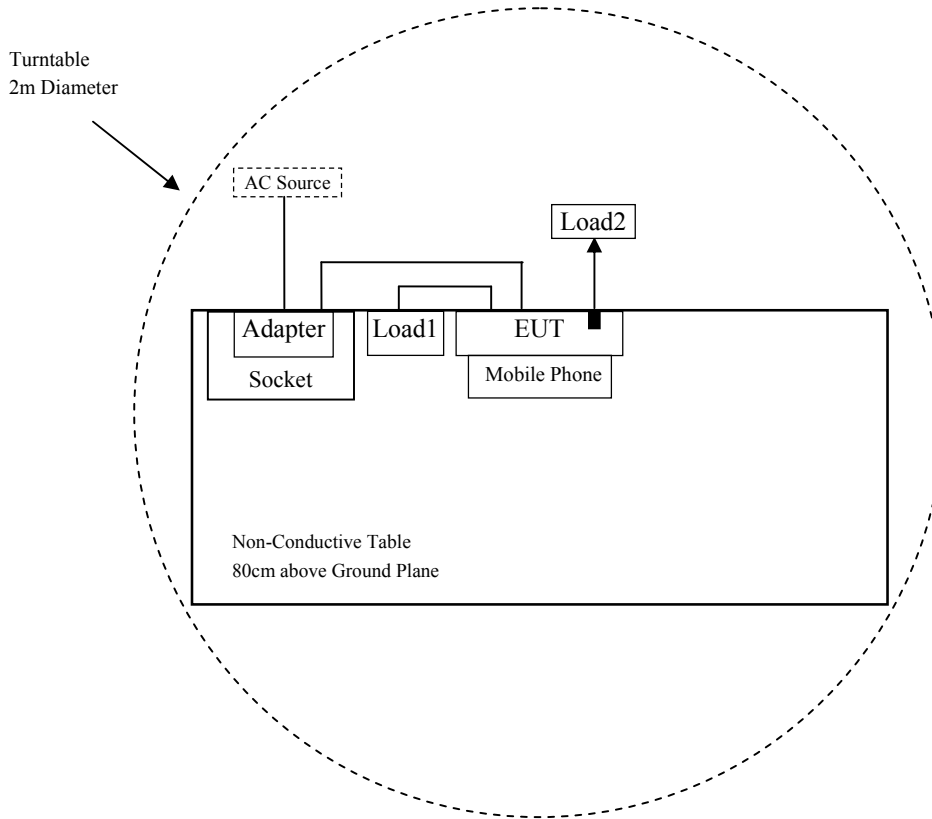

SUMMARY OF TEST RESULTS

FCC Rules	Description of Test	Result
§1.1307 & §1.1310&§2.1091	Maximum Permissible Exposure (MPE)	Compliant
§15.203	Antenna Requirement	Compliant
§15.207 (a)	AC Line Conducted Emissions	Compliant
§15.205, §15.209	Spurious Emissions	Compliant

TEST EQUIPMENT LIST

Manufacturer	Description	Model	Serial Number	Calibration Date	Calibration Due Date
Radiated Emission Test (Chamber 1#)					
Rohde & Schwarz	EMI Test Receiver	ESCI	100195	2019-12-14	2020-12-13
Sunol Sciences	Broadband Antenna	JB3	A090413-1	2020-08-05	2023-08-04
Sonoma Instrument	Pre-amplifier	310N	171205	2020-08-14	2021-08-13
ETS-LINDGREN	Loop Antenna	6512	00108100	2019-04-25	2022-04-24
Rohde & Schwarz	Auto Test Software	EMC32	100361	/	/
MICRO-COAX	Coaxial Cable	Cable-8	008	2020-08-15	2021-08-14
MICRO-COAX	Coaxial Cable	Cable-9	009	2020-08-15	2021-08-14
MICRO-COAX	Coaxial Cable	Cable-10	010	2020-08-15	2021-08-14
Radiated Emission Test (Chamber 2#)					
Rohde & Schwarz	EMI Test Receiver	ESU40	100207	2020-04-01	2021-03-31
Rohde & Schwarz	Signal Analyzer	FSU26	200103	2020-07-28	2021-07-27
ETS-LINDGREN	PASSIVE LOOP	6512	108100	2019-04-25	2022-04-24
Sonoma Instrument	Pre-amplifier	310N	185700	2020-08-14	2021-08-13
Rohde & Schwarz	Auto test Software	EMC32	100361	/	/
MICRO-COAX	Coaxial Cable	Cable-6	006	2020-12-12	2021-12-11
MICRO-COAX	Coaxial Cable	Cable-11	011	2020-08-15	2021-08-14
MICRO-COAX	Coaxial Cable	Cable-12	012	2020-08-15	2021-08-14
MICRO-COAX	Coaxial Cable	Cable-13	013	2020-08-15	2021-08-14
Conducted Emission Test					
Rohde & Schwarz	EMI Test Receiver	ESR	1316.3003K03-101746-zn	2020-08-05	2021-08-04
Rohde & Schwarz	LISN	ENV216	101115	2020-12-14	2021-12-13
Audix	Test Software	e3	V9	/	/
Rohde & Schwarz	Pulse limiter	ESH3-Z2	0357.8810.54	2020-08-10	2021-08-09
MICRO-COAX	Coaxial Cable	Cable-15	015	2020-08-15	2021-08-14
RF Exposure					
Narda	E-Field Tester	NARD-EA5091	/	2019-11-19	2021-11-18
Narda	B Field Meter	NBM-550	B-1130	2019-11-19	2021-11-18
ETS-LINDGREN	Isotropic Electric Field Probe	HI-6005	00200234	2018-05-22	2021-05-21

* **Statement of Traceability:** Bay Area Compliance Laboratories Corp. (Kunshan) attests that all calibrations have been performed in accordance to requirements that traceable to National Primary Standards and International System of Units (SI).

FCC §1.1307& §1.1310& §2.1091 – MAXIMUM PERMISSIBLE EXPOSURE (MPE)

Applicable Standard

FCC §1.1307 & 1.1310 & §2.1091

According to the item 5(b) of KDB 680106 D01 RF Exposure Wireless Charging Apps v03: Inductive wireless power transfer applications that meet all of the following requirements are excluded from submitting an RF evaluation.

- a) Power transfer frequency is less than 1 MHz.
- b) Output power from each primary coil is less than or equal to 15 watts.
- c) The transfer system includes only single primary and secondary coils. This includes charging systems that may have multiple primary coils and clients that are able to detect and allow coupling only between individual pairs of coils.
- d) Client device is placed directly in contact with the transmitter.
- e) Mobile exposure conditions only (portable exposure conditions are not covered by this exclusion).
- f) The aggregate H-field strengths at 15 cm surrounding the device and 20 cm above the top surface from all simultaneous transmitting coils are demonstrated to be less than 50% of the MPE limit.

Limits for Maximum Permissible Exposure (MPE)

(B) Limits for General Population/Uncontrolled Exposure				
Frequency Range (MHz)	Electric Field Strength (V/m)	Magnetic Field Strength (A/m)	Power Density (mW/cm²)	Averaging Time (minutes)
(A) Limits for Occupational/Controlled Exposure				
0.3-3.0	614	1.63	*100	6
3.0-30	1842/f	4.89/f	*900/f ²	6
30-300	61.4	0.163	1.0	6
300-1,500	/	/	f/300	6
1,500-100,000	/	/	5	6
(B) Limits for General Population/Uncontrolled Exposure				
0.3-1.34	614	1.63	*(100)	30
1.34-30	824/f	2.19/f	*(180/f ²)	30
30-300	27.5	0.073	0.2	30
300-1500	/	/	f/1500	30
1500-100,000	/	/	1.0	30

f = frequency in MHz; * = Plane-wave equivalent power density;

EUT Setup

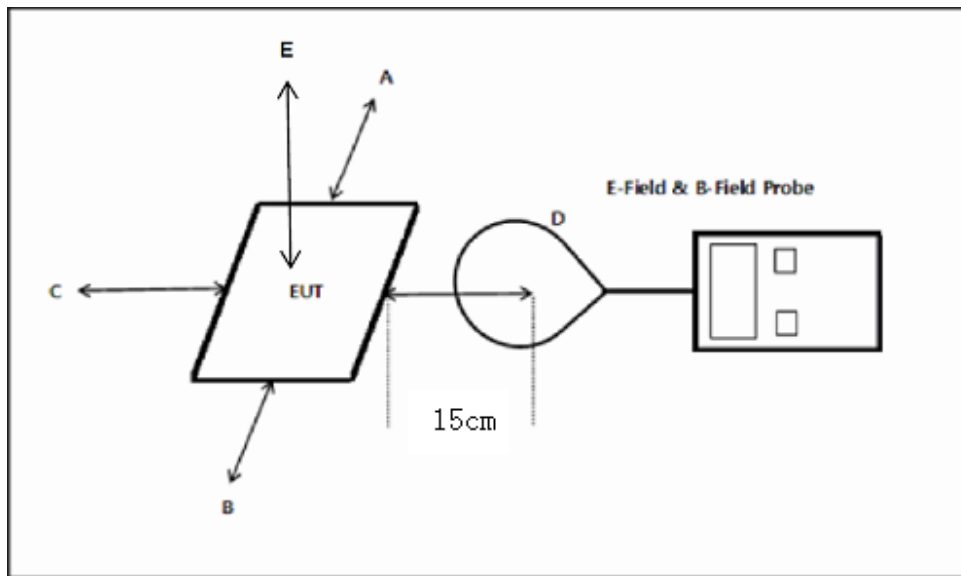

Result

a) Power transfer frequency is less than 1 MHz.

Yes, the device operates in the frequency 115 kHz-130 kHz.

b) Output power from each primary coil is less than or equal to 15 watts.

Yes, the maximum output power of the primary coil is $10W < 15W$.

c) The transfer system includes only single primary and secondary coils. This includes charging systems that may have multiple primary coils and clients that are able to detect and allow coupling only between individual pairs of coils.

Yes, the transfer system including a charging system with only single primary coils is to detect and allow only between individual of coils.

d) Client device is inserted in or placed directly in contact with the transmitter.

Yes, client device is placed directly in contact with the transmitter.

e) Mobile exposure conditions only (portable exposure conditions are not covered by this exclusion).

Yes, this is a mobile device.

f) The aggregate H-field strengths at 15 cm surrounding the device and 20 cm above the top surface from all simultaneous transmitting coils are demonstrated to be less than 50% of the MPE limit.

The EUT H-field Strength levels at 15 cm surrounding the device and 20 cm above the top surface are less than 50% the MPE limit.

Test Data

Environmental Conditions

Temperature:	24.7 °C
Relative Humidity:	51 %
ATM Pressure:	101.2 kPa

The testing was performed by CK Huang on 2020-11-09.

H-Field Strength

Frequency Range (kHz)	Position A (A/m)	Position B (A/m)	Position C (A/m)	Position D (A/m)	Position E (A/m)	50% Limit (A/m)	Limit (A/m)
115-130	0.087	0.049	0.068	0.064	0.234	0.815	1.63

E- Field Strength

Frequency Range (kHz)	Position A (V/m)	Position B (V/m)	Position C (V/m)	Position D (V/m)	Position E (V/m)	50% Limit (V/m)	Limit (V/m)
115-130	1.910	1.101	1.562	1.432	2.136	307	614

Note:

1: According with KDB 680106 D01 RF Exposure Wireless Charging Apps v03, Emissions between 100 kHz to 300 kHz should be assessed versus the limits at 300 kHz in Table 1 of Section 1.1310: 614 V/m and 1.63 A/m.

2: The distance for position A, B, C, D are 15cm, the distance for position E is 20cm.

FCC §15.203 - ANTENNA REQUIREMENT

Applicable Standard

An intentional radiator shall be designed to ensure that no antenna other than that furnished by the responsible party shall be used with the device. The use of a permanently attached antenna or of an antenna that uses a unique coupling to the intentional radiator shall be considered sufficient to comply with the provisions of this section.

Antenna Connector Construction

The EUT has a Loop antenna and the antenna gain is 0.0 dBi, fulfill the requirement of this section. Please refer to the EUT photos.

Result: Compliant.

FCC §15.207 (a) – AC LINE CONDUCTED EMISSIONS

Applicable Standard

FCC §15.207(a)

EUT Setup

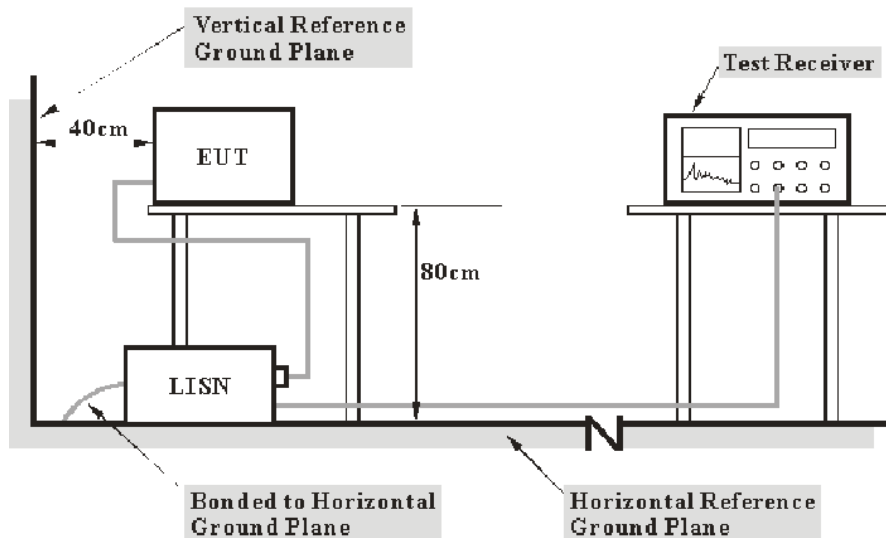

- Note: 1. Support units were connected to second LISN.
 2. Both of LISNs (AMN) 80 cm from EUT and at the least 80 cm from other units and other metal planes support units.

The setup of EUT is according with per ANSI C63.10-2013 measurement procedure. The specification used was with the FCC Part 15.207 limits.

EMI Test Receiver Setup

The EMI test receiver was set to investigate the spectrum from 150 kHz to 30 MHz.

During the conducted emission test, the EMI test receiver was set with the following configurations:

Frequency Range	IF B/W
150 kHz – 30 MHz	9 kHz

Test Procedure

During the conducted emission test, the adapter was connected to the outlet of the LISN.

Maximizing procedure was performed on the six (6) highest emissions of the EUT.

All data was recorded in the Quasi-peak and average detection mode.

Factor & Over Limit Calculation

The Corrected Factor is calculated by adding LISN VDF (Voltage Division Factor), Cable Loss and Transient Limiter Attenuation. The basic equation is as follows:

$$\text{Factor (dB)} = \text{LISN VDF (dB)} + \text{Cable Loss (dB)} + \text{Transient Limiter Attenuation (dB)}$$

The “**Over Limit**” column of the following data tables indicates the degree of compliance with the applicable limit. For example, an over limit of 7dB means the emission is 7 dB above the limit. The equation for over limit calculation is as follows:

$$\text{Over Limit (dB)} = \text{Read level (dB}\mu\text{V)} + \text{Factor (dB)} - \text{Limit (dB}\mu\text{V)}$$

Test Results Summary

According to the recorded data in following table, the EUT complied with the FCC Part 15.207.

Test Data

Environmental Conditions

Temperature:	24.9 °C
Relative Humidity:	51 %
ATM Pressure:	101.2 kPa

The testing was performed by CK Huang on 2020-11-06.

EUT operation mode: charging and communication

AC 120V/60 Hz, Line

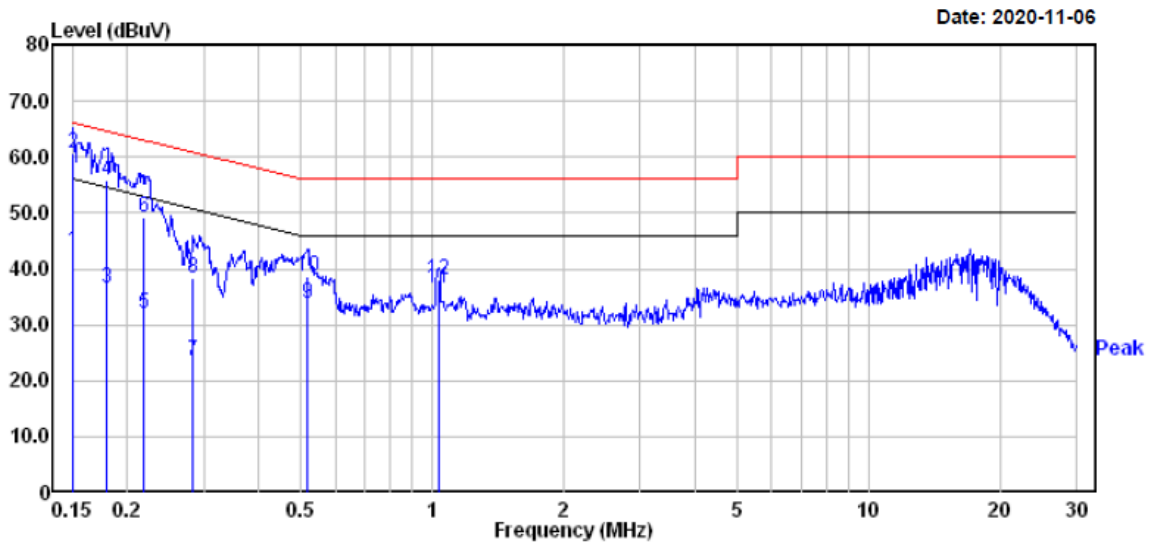

	Freq	Read Level	Factor	Level	Limit Line	Over Limit	Remark
	MHz	dBuV	dB	dBuV	dBuV	dB	
1	0.150	23.20	19.82	43.02	56.00	-12.98	Average
2	0.150	40.80	19.82	60.62	66.00	-5.38	QP
3	0.179	16.80	19.83	36.63	54.55	-17.92	Average
4	0.179	35.90	19.83	55.73	64.55	-8.82	QP
5	0.217	12.10	19.82	31.92	52.92	-21.00	Average
6	0.217	29.50	19.82	49.32	62.92	-13.60	QP
7	0.283	3.80	19.82	23.62	50.72	-27.10	Average
8	0.283	18.50	19.82	38.32	60.72	-22.40	QP
9	0.518	14.10	19.76	33.86	46.00	-12.14	Average
10	0.518	19.00	19.76	38.76	56.00	-17.24	QP
11	1.032	16.60	19.82	36.42	46.00	-9.58	Average
12	1.032	18.20	19.82	38.02	56.00	-17.98	QP

AC 120V/60 Hz, Neutral

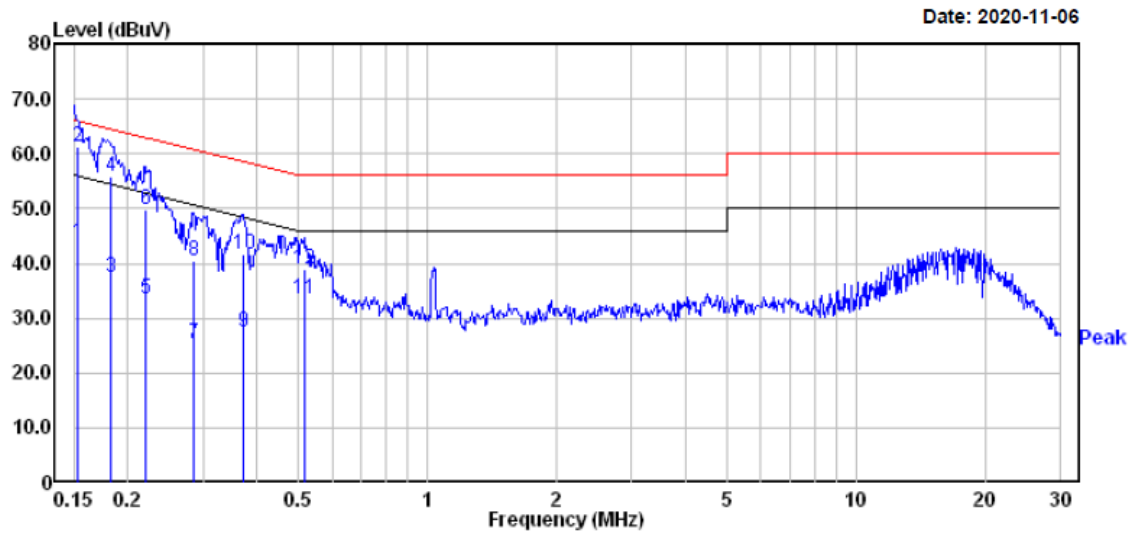

	Read Freq	Read Level	Factor	Level	Limit Line	Over Limit	Remark
	MHz	dBuV	dB	dBuV	dBuV	dB	
1	0.152	24.10	19.82	43.92	55.87	-11.95	Average
2	0.152	41.40	19.82	61.22	65.87	-4.65	QP
3	0.182	17.60	19.83	37.43	54.37	-16.94	Average
4	0.182	36.00	19.83	55.83	64.37	-8.54	QP
5	0.220	13.70	19.82	33.52	52.83	-19.31	Average
6	0.220	30.00	19.82	49.82	62.83	-13.01	QP
7	0.285	5.40	19.82	25.22	50.68	-25.46	Average
8	0.285	20.70	19.82	40.52	60.68	-20.16	QP
9	0.371	7.70	19.78	27.48	48.47	-20.99	Average
10	0.371	21.90	19.78	41.68	58.47	-16.79	QP
11	0.516	13.90	19.76	33.66	46.00	-12.34	Average
12	0.516	19.10	19.76	38.86	56.00	-17.14	QP

Note:

- 1) Factor (dB) = LISN VDF (dB) + Cable Loss (dB) + Transient Limiter Attenuation (dB)
- 2) Over Limit (dB) = Read level (dBμV) + Factor (dB) - Limit (dBμV)

FCC §15.209 & §15.205 - SPURIOUS EMISSIONS

Applicable Standard

FCC §15.209; §15.205;

EUT Setup

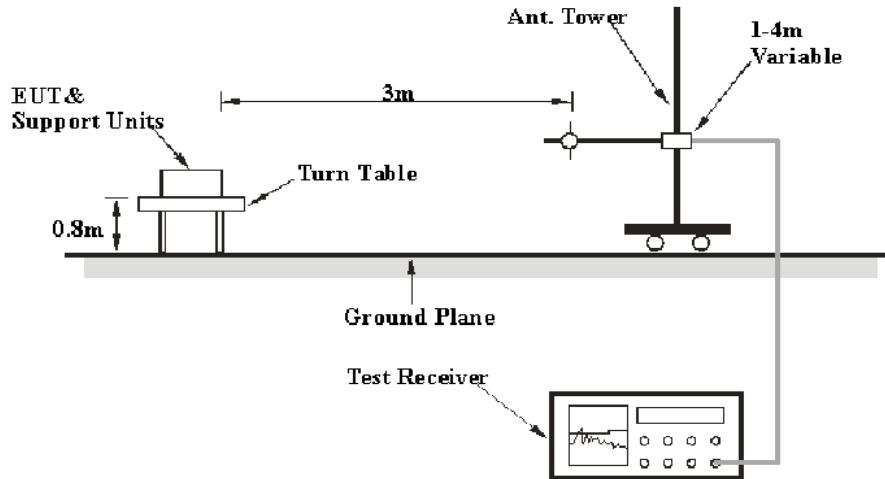

The radiated emission tests were performed in the 3 meters chamber test site, using the setup accordance with the ANSI C63.10-2013. The specification used was the FCC 15.209 and FCC 15.205 limits.

EMI Test Receiver Setup

The system was investigated from 9 kHz to 1GHz.

During the radiated emission test, the EMI test receiver setup was set with the following configurations:

Frequency Range	RBW	Video B/W	Detector
9 kHz – 150 kHz	200 Hz	1 kHz	QP/Average
150 kHz – 30MHz	9kHz	30kHz	QP/Average
30 MHz – 1000 MHz	120 kHz	300 kHz	QP

Note: For the frequency bands 9-90 kHz and 110-490 kHz, the test was based on average detector.

Test Procedure

Maximizing procedure was performed on the highest emissions to ensure that the EUT complied with all installation combinations.

The EUT is set 3 meter away from the testing antenna, which is varied from 1-4 meter, and the EUT is placed on a turntable, which is 0.8 meter above ground plane, the table shall be rotated for 360 degrees to find out the highest emission. The receiving antenna should be changed the polarization both of horizontal and vertical.

Corrected Amplitude & Margin Calculation

The Corrected Amplitude is calculated by adding the Antenna Factor and Cable Loss, and subtracting the Amplifier Gain from the Meter Reading. The basic equation is as follows:

Corrected Amplitude (dB μ V /m) = Meter Reading (dB μ V) + Antenna Factor (dB/m) + Cable Loss (dB) - Amplifier Gain (dB)

The “**Margin**” column of the following data tables indicates the degree of compliance with the applicable limit. For example, a margin of 7dB means the emission is 7dB below the limit. The equation for margin calculation is as follows:

Margin (dB) = Limit (dB μ V/m) – Corrected Amplitude (dB μ V /m)

Test Results Summary

According to the recorded data in following table, the EUT complied with the FCC Title 47, Part 15, Subpart C, section 15.205 and 15.209.

Test Data

Environmental Conditions

Temperature:	24.7~25.3 °C
Relative Humidity:	50~51 %
ATM Pressure:	101.2~102.7 kPa

The testing was performed by CK Huang from 2020-11-09 to 2020-11-10.

EUT operation mode: charging and communication

9kHz-30MHz:

(Pre-scan in the X, Y and Z axes of orientation, the worst case in X-axis of orientation was recorded)

9kHz-150kHz (PK)

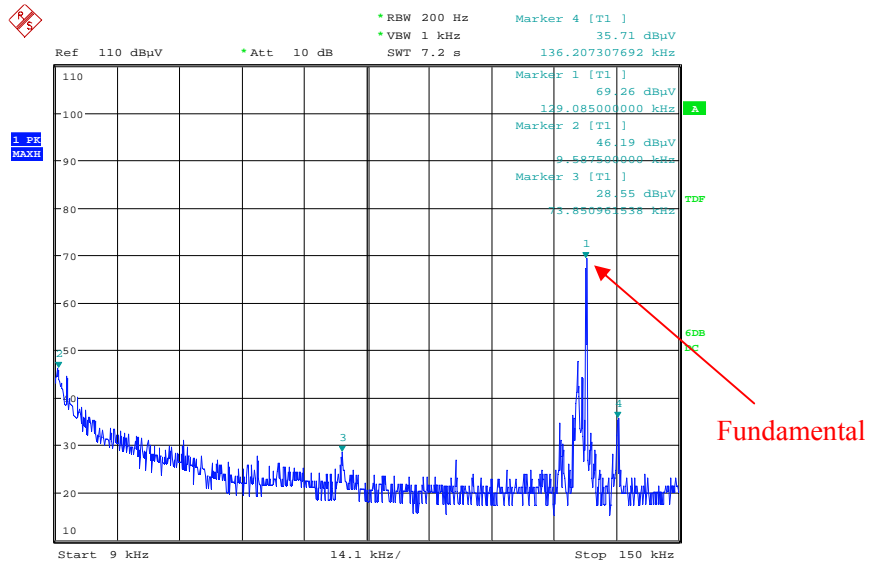

Date: 10.NOV.2020 02:33:04

150kHz-30MHz (PK)

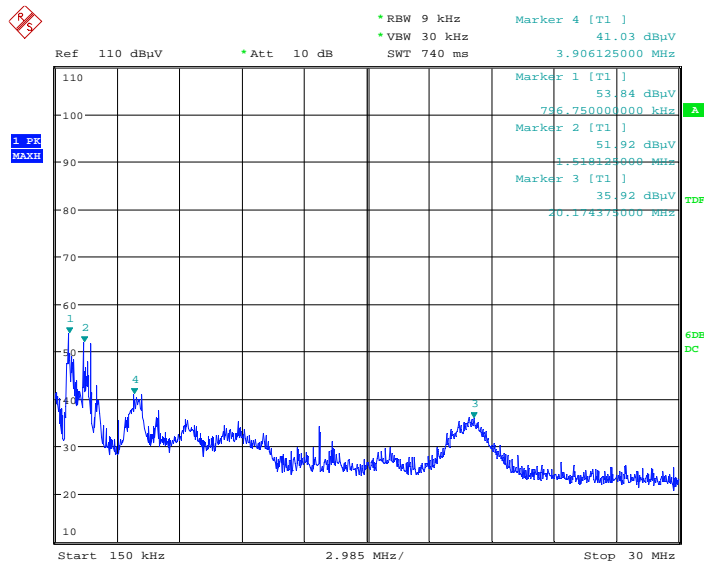

Date: 10.NOV.2020 02:35:20

9kHz-490kHz:

Indicated		Detector (PK/AV/QP)	Corrected Factor (dB/m)	FCC Part 15.209		
Frequency (kHz)	Corrected Amplitude (dBµV/m) @3m			Limit (dBµV/m) @3m	Limit (dBµV/m) @300m	Margin (dB)
9.58	46.19	PK	56.63	127.97	47.97	81.78
73.85	28.55	PK	45.91	110.23	30.23	81.68
129.08	69.26	PK	50.60	105.38	25.38	36.12
136.20	35.71	PK	50.70	104.92	24.92	69.21

490kHz-30MHz

Indicated		Detector (PK/AV/QP)	Corrected Factor (dB/m)	FCC Part 15.209		
Frequency (MHz)	Corrected Amplitude (dBµV/m) @3m			Limit (dBµV/m) @3m	Limit (dBµV/m) @30m	Margin (dB)
0.79	53.84	PK	19.47	69.65	29.65	15.81
1.51	51.92	PK	15.91	64.02	24.02	12.10
3.90	41.03	PK	18.12	69.54	29.54	28.51
20.17	35.92	PK	5.59	69.54	29.54	33.62

Note:

The average emissions which fall into frequencies 9-90 kHz, 110-490 kHz was not recorded, because the peak emissions are below the average limit.

Corrected Factor (dB/m) = Antenna factor (RX) (dB/m) + Cable Loss (dB) – Amplifier Factor (dB)

Corrected Amplitude (dBµV/m) = Corrected Factor (dB/m) + Reading (dBµV)

Margin (dB) = Limit (dBµV/m) – Corrected Amplitude (dBµV/m)

30MHz-1GHz

(Pre-scan in the X,Y and Z axes of orientation, the worst case in X-axis of orientation was recorded)

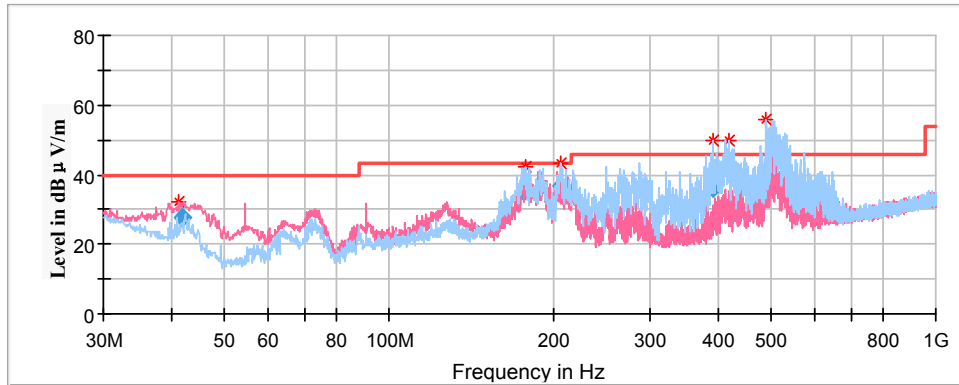

Frequency (MHz)	Corrected Amplitude (dB μV/m)	Rx Antenna		Turntable Degree	Corrected Factor (dB/m)	Limit (dBμV/m)	Margin (dB)
		Height (cm)	Polar (H/V)				
41.752050	27.45	100.0	V	95.0	-12.4	40.00	12.55
176.493700	35.28	200.0	H	0.0	-13.3	43.50	8.22
206.553450	36.70	100.0	H	345.0	-12.1	43.50	6.80
392.676700	36.32	100.0	H	118.0	-8.8	46.00	9.68
420.208100	40.71	100.0	H	105.0	-8.1	46.00	5.29
491.273050	36.61	200.0	H	147.0	-6.2	46.00	9.39

Note:

Corrected Factor (dB/m) = Antenna factor (RX) (dB/m) + Cable Loss (dB) – Amplifier Factor (dB)

Corrected Amplitude (dBμV/m) = Corrected Factor (dB/m) + Reading (dBμV)

Margin (dB) = Limit (dBμV/m) – Corrected Amplitude (dBμV/m)

Declarations

1: BACL is not responsible for the authenticity of any test data provided by the applicant. Data included from the applicant that may affect test results are marked with an asterisk '*'. Customer model name, addresses, names, trademarks etc. are not considered data.

2: Unless otherwise stated the results shown in this test report refer only to the sample(s) tested.

3: Otherwise required by the applicant or Product Regulations, Decision Rule in this report did not consider the uncertainty.

4: The extended uncertainty given in this report is obtained by combining the standard uncertainty times the coverage factor K with the 95% confidence interval.

5: This report cannot be reproduced except in full, without prior written approval of the Company.

6: This report is valid only with a valid digital signature. The digital signature may be available only under the Adobe software above version 7.0.

******* END OF REPORT *******