



MEASUREMENT REPORT

FCC PART 15.249

FCC ID: 2ANKDJCHR35H2
APPLICANT: ZHEJIANG JIECANG LINEAR MOTION TECHNOLOGY CO., LTD
Application Type: Certification
Product: Remote Control
Model No.: JCHR35H2
FCC Classification: Low Power Communication Device Transmitter (DXX)
FCC Rule Part(s): Part 15.249
Test Procedure(s): ANSI C63.10 - 2013
Test Date: November 10 ~ 26, 2017

Reviewed By : Kevin Guo
(Kevin Guo)
Approved By : Marlin Chen
(Marlin Chen)



The test results relate only to the samples tested.

This equipment has been shown to be capable of compliance with the applicable technical standards as indicated in the measurement report and was tested in accordance with the measurement procedures specified in ANSI C63.10-2013. Test results reported herein relate only to the item(s) tested.

The test report shall not be reproduced except in full without the written approval of MRT Technology (Suzhou) Co., Ltd.

Revision History

Report No.	Version	Description	Issue Date	Note
1709WSU00402	Rev. 01	Initial report	12-20-2017	Valid

CONTENTS

Description	Page
1. INTRODUCTION	6
1.1. Scope	6
1.2. MRT Test Location	6
2. PRODUCT INFORMATION	7
2.1. Equipment Description.....	7
2.2. Operation Frequency and Channel List.....	7
2.3. Test Configuration	7
2.4. EMI Suppression Device(s)/Modifications.....	7
2.5. Labeling Requirements	8
3. DESCRIPTION OF TEST	9
3.1. Evaluation Procedure	9
3.2. AC Line Conducted Emissions	9
3.3. Radiated Emissions.....	10
4. ANTENNA REQUIREMENTS	11
5. TEST EQUIPMENT CALIBRATION DATE	12
6. MEASUREMENT UNCERTAINTY.....	13
7. TEST RESULT	14
7.1. Summary	14
7.2. Conducted Emission.....	14
7.2.1. Test Limit	15
7.2.2. Test Setup.....	15
7.2.3. Test Result.....	15
7.3. Radiated Emission.....	16
7.3.1. Test Limit	16
7.3.2. Test Setup.....	17
7.3.3. Test Result.....	19
7.4. Radiated Restricted Band Edge Measurement	25
7.4.1. Test Result.....	25
7.5. Output Power Measurement.....	29
7.5.1. Test Limit	29
7.5.2. Test Procedure Used	29
7.5.3. Test Setting	29
7.5.4. Test Setup.....	29

7.5.5.	Test Result of Output Power	30
7.6.	20dB Spectrum Bandwidth Measurement	31
7.6.1.	Test Limit	31
7.6.2.	Test Procedure used	31
7.6.3.	Test Setting	31
7.6.4.	Test Setup.....	31
7.6.5.	Test Result.....	32
7.7.	99% Bandwidth Measurement	33
7.7.1.	Test Limit	33
7.7.2.	Test Procedure used	33
7.7.3.	Test Setting	33
7.7.4.	Test Setup.....	33
7.7.5.	Test Result.....	34
8.	CONCLUSION.....	35

§2.1033 General Information

Applicant:	ZHEJIANG JIECANG LINEAR MOTION TECHNOLOGY CO., LTD
Applicant Address:	No.19 XinTao Road, Provincial High Tech Park XinChang county,ZheJiang Province
Manufacturer:	ZHEJIANG JIECANG LINEAR MOTION TECHNOLOGY CO., LTD
Manufacturer Address:	No.19 XinTao Road, Provincial High Tech Park XinChang county,ZheJiang Province
Test Site:	MRT Technology (Suzhou) Co., Ltd
Test Site Address:	D8 Building, Youxin Industrial Park, No.2 Tian’edang Rd., Wuzhong Economic Development Zone, Suzhou, China
FCC Registration No.:	893164
Test Device Serial No.:	N/A <input type="checkbox"/> Production <input checked="" type="checkbox"/> Pre-Production <input type="checkbox"/> Engineering

Test Facility / Accreditations

Measurements were performed at MRT Laboratory located in Tian’edang Rd., Suzhou, China.

- MRT facility is a FCC registered (MRT Reg. No. 893164) test facility with the site description report on file and has met all the requirements specified in Section 2.948 of the FCC Rules.
- MRT facility is an IC registered (MRT Reg. No. 11384A-1) test laboratory with the site description on file at Industry Canada.
- MRT facility is a VCCI registered (R-4179, G-814, C-4664, T-2206) test laboratory with the site description on file at VCCI Council.
- MRT Lab is accredited to ISO 17025 by the American Association for Laboratory Accreditation (A2LA) under the American Association for Laboratory Accreditation Program (A2LA Cert. No. 3628.01) in EMC, Telecommunications and Radio testing for FCC, Industry Canada, EU and TELEC Rules.



1. INTRODUCTION

1.1. Scope

Measurement and determination of electromagnetic emissions (EMC) of radio frequency devices including intentional and/or unintentional radiators for compliance with the technical rules and regulations of the Federal Communications Commission and the Industry Canada Certification and Engineering Bureau.

1.2. MRT Test Location

The map below shows the location of the MRT LABORATORY, its proximity to the Taihu Lake. These measurement tests were conducted at the MRT Technology (Suzhou) Co., Ltd. Facility located at D8 Building, Youxin Industrial Park, No.2 Tian'edang Rd., Wuzhong Economic Development Zone, Suzhou, China. The detailed description of the measurement facility was found to be in compliance with the requirements of § 2.948 according to ANSI C63.4-2009 on September 30, 2013.



2. PRODUCT INFORMATION

2.1. Equipment Description

Product Name	Remote Control
Model No.	JCHR35H2
Frequency Range	2404 ~ 2479 MHz
Type of Modulation	GFSK

2.2. Operation Frequency and Channel List

No	Channel	Frequency
1	LOW	2404 MHz
2	...	2418 MHz
3	MID	2420 MHz
4	...	2469 MHz
5	HIG	2479 MHz

2.3. Test Configuration

The EUT was tested as described in this report is in compliance with the requirements limits of FCC Rules Part 15.207, 15.209, 15.215 and 15.249. ANSI C63.10-2013 was used to reference the appropriate EUT setup for radiated spurious emissions testing and AC line conducted testing.

2.4. EMI Suppression Device(s)/Modifications

No EMI suppression device(s) were added and/or no modifications were made during testing.

2.5. Labeling Requirements

Per 2.1074 & 15.19; Docket 95-19

The label shall be permanently affixed at a conspicuous location on the device; instruction manual or pamphlet supplied to the user and be readily visible to the purchaser at the time of purchase.

However, when the device is so small wherein placement of the label with specified statement is not practical, only the FCC ID must be displayed on the device per Section 15.19(a)(5). Please see attachment for FCC ID label and label location.

3. DESCRIPTION OF TEST

3.1. Evaluation Procedure

The measurement procedures described in the American National Standard for Testing Unlicensed Wireless Devices (ANSI C63.10-2013), and the requirements provided in FCC 15.207, 15.209, 15.215 and 15.249 were performed in the report of the EUT.

Deviation from measurement procedure.....None

3.2. AC Line Conducted Emissions

The line-conducted facility is located inside an 8'x4'x4' shielded enclosure. A 1m x 2m wooden table 80cm high is placed 40cm away from the vertical wall and 80cm away from the sidewall of the shielded room. Two 10kHz-30MHz, 50Ω/50uH Line-Impedance Stabilization Networks (LISNs) are bonded to the shielded room floor. Power to the LISNs is filtered by external high-current high-insertion loss power line filters. These filters attenuate ambient signal noise from entering the measurement lines. These filters are also bonded to the shielded enclosure.

The EUT is powered from one LISN and the support equipment is powered from the second LISN. All interconnecting cables more than 1 meter were shortened to a 1 meter length by non-inductive bundling (serpentine fashion) and draped over the back edge of the test table. All cables were at least 40cm above the horizontal reference ground-plane. Power cables for support equipment were routed down to the second LISN while ensuring that that cables were not draped over the second LISN.

Sufficient time for the EUT, support equipment, and test equipment was allowed in order for them to warm up to their normal operating condition. The RF output of the LISN was connected to the receiver and exploratory measurements were made to determine the frequencies producing the maximum emission from the EUT. The receiver was scanned from 150kHz to 30MHz. The detector function was set to peak mode for exploratory measurements while the bandwidth of the analyzer was set to 9kHz. The EUT, support equipment, and interconnecting cables were arranged and manipulated to maximize each emission. Each emission was also maximized by varying: power lines, the mode of operation or data exchange speed, or support equipment whichever determined the worst-case emission. Once the worst case emissions have been identified, the one EUT cable configuration/arrangement and mode of operation that produced these emissions are used for final measurements on the same test site. The analyzer is set to CISPR quasi-peak and average detectors with a 9kHz resolution bandwidth for final measurements.

An extension cord was used to connect to a single LISN which powered by EUT. The extension cord was calibrated with LISN, the impedance and insertion loss are compliance with the requirements as stated in ANSI C63.10-2013.

3.3. Radiated Emissions

The radiated test facilities consisted of an indoor 3 meter semi-anechoic chamber used for final measurements and exploratory measurements, when necessary. The measurement area is contained within the semi-anechoic chamber which is shielded from any ambient interference. For measurements above 1GHz absorbers are arranged on the floor between the turn table and the antenna mast in such a way so as to maximize the reduction of reflections. For measurements below 1GHz, the absorbers are removed. A MF Model 210SS turntable is used for radiated measurement. It is a continuously rotatable, remote controlled, metallic turntable and 2 meters (6.56 ft.) in diameter. The turn table is flush with the raised floor of the chamber in order to maintain its function as a ground plane. An 80cm high PVC support structure is placed on top of the turntable.

For all measurements, the spectrum was scanned through all EUT azimuths and from 1 to 4 meter receive antenna height using a broadband antenna from 30MHz up to the upper frequency shown in 15.33(b)(1) depending on the highest frequency generated or used in the device or on which the device operates or tunes. For frequencies above 1GHz, linearly polarized double ridge horn antennas were used. For frequencies below 30MHz, a calibrated loop antenna was used. When exploratory measurements were necessary, they were performed at 1 meter test distance inside the semi-anechoic chamber using broadband antennas, broadband amplifiers, and spectrum analyzers to determine the frequencies and modes producing the maximum emissions. Sufficient time for the EUT, support equipment, and test equipment was allowed in order for them to warm up to their normal operating condition. The test set-up for frequencies below 1GHz was placed on top of the 0.8 meter high, 1 x 1.5 meter table; and test set-up for frequencies 1-25GHz was placed on top of the 1.5 meter high, 1 x 1.5 meter table. The EUT, support equipment, and interconnecting cables were arranged and manipulated to maximize each emission. Appropriate precaution was taken to ensure that all emissions from the EUT were maximized and investigated. The system configuration, clock speed, mode of operation or video resolution, if applicable, turntable azimuth, and receive antenna height was noted for each frequency found.

Final measurements were made in the semi-anechoic chamber using calibrated, linearly polarized broadband and horn antennas. The test setup was configured to the setup that produced the worst case emissions. The spectrum analyzer was set to investigate all frequencies required for testing to compare the highest radiated disturbances with respect to the specified limits. The turntable containing the EUT was rotated through 360 degrees and the height of the receive antenna was varied 1 to 4 meters and stopped at the azimuth and height producing the maximum emission. Each emission was maximized by changing the orientation of the EUT through three orthogonal planes and changing the polarity of the receive antenna, whichever produced the worst-case emissions. According to 3dB Beam-Width of horn antenna, the horn antenna should be always directed to the EUT when rising height.

4. ANTENNA REQUIREMENTS

Excerpt from §15.203 of the FCC Rules/Regulations:

“An intentional radiator antenna shall be designed to ensure that no antenna other than that furnished by the responsible party can be used with the device. The use of a permanently attached antenna or of an antenna that uses a unique coupling to the intentional radiator shall be considered sufficient to comply with the provisions of this section.”

- The antenna of the EUT **is permanently attached.**
- There are no provisions for connection to an external antenna.

Conclusion:

This unit complies with the requirement of §15.203.

5. TEST EQUIPMENT CALIBRATION DATE

Conducted Emissions - SR2

Instrument	Manufacturer	Type No.	Asset No.	Cali. Interval	Cali. Due Date
EMI Test Receiver	R&S	ESR7	MRTSUE06001	1 year	2018/06/20
Two-Line V-Network	R&S	ENV216	MRTSUE06002	1 year	2018/06/20
Two-Line V-Network	R&S	ENV216	MRTSUE06003	1 year	2018/06/20
Temperature/Humidity Meter	Yuhuaze	HTC-2	MRTSUE06181	1 year	2017/12/20
Shielding Anechoic Chamber	Mikebang	Chamber-SR2	MRTSUE06214	1 year	2018/05/10

Radiated Emission - AC1

Instrument	Manufacturer	Type No.	Asset No.	Cali. Interval	Cali. Due Date
MXE EMI Receiver	Agilent	N9038A	MRTSUE06125	1 year	2018/08/18
Microwave System Amplifier	Agilent	83017A	MRTSUE06076	1 year	2018/03/28
Preamplifier	Schwarzbeck	BBV 9721	MRTSUE06121	1 year	2018/04/16
Loop Antenna	Schwarzbeck	FMZB1519	MRTSUE06025	1 year	2018/11/21
Bilog Period Antenna	Schwarzbeck	VULB 9168	MRTSUE06172	1 year	2017/12/10
Horn Antenna	Schwarzbeck	BBHA9120D	MRTSUE06023	1 year	2018/10/21
Broadband Horn Antenna	Schwarzbeck	BBHA9170	MRTSUE06024	1 year	2018/01/04
Temperature/Humidity Meter	Yuhuaze	HTC-2	MRTSUE06183	1 year	2017/12/22
Anechoic Chamber	TDK	Chamber-AC1	MRTSUE06212	1 year	2018/05/10

Conducted Test Equipment - TR3

Instrument	Manufacturer	Type No.	Asset No.	Cali. Interval	Cali. Due Date
MXE EMI Receiver	Agilent	N9038A	MRTSUE06125	1 year	2018/08/18
Temperature/Humidity Meter	Yuhuaze	HTC-2	MRTSUE06180	1 year	2017/12/20

Software	Version	Function
e3	V8.3.5	EMI Test Software

6. MEASUREMENT UNCERTAINTY

Where relevant, the following test uncertainty levels have been estimated for tests performed on the EUT as specified in CISPR 16-4-2. This uncertainty represents an expanded uncertainty expressed at approximately the 95% confidence level using a coverage factor of $k = 2$.

AC Conducted Emission Measurement - SR2
Measuring Uncertainty for a Level of Confidence of 95% ($U=2Uc(y)$): 150kHz~30MHz: 3.46dB
Radiated Emission Measurement – AC1
Measuring Uncertainty for a Level of Confidence of 95% ($U=2Uc(y)$): 9kHz ~ 1GHz: 4.18dB 1GHz ~ 25GHz: 4.76dB
20dB Spectrum Bandwidth - TR3
Measuring Uncertainty for a Level of Confidence of 95% ($U=2Uc(y)$): 0.28%

7. TEST RESULT

7.1. Summary

Company Name: ZHEJIANG JIECANG LINEAR MOTION TECHNOLOGY CO., LTD

Product: Remote Control

FCC Part Section(s)	Test Description	Test Limit	Test Condition	Test Result	Reference
15.207	AC Conducted Emissions 150kHz - 30MHz	< FCC 15.207 limits	Line Conducted	N/A	Section 7.2
15.209 15.249	General Field Strength Limits (Restricted Bands and Radiated Emission Limits)	Emissions in restricted bands must meet the radiated limits detailed in 15.209	Radiated	Pass	Section 7.3 & 7.4
15.215(c)	20dB Spectrum Bandwidth	20 dB bandwidth of the emission in the specific band	Conducted	Pass	Section 7.5

Notes:

- 1) All modes of operation and data rates were investigated. For radiated emission test, every axis (X, Y, Z) was also verified. The test results shown in the following sections represent the worst case emissions.
- 2) The analyzer plots shown in this section were all taken with a correction table loaded into the analyzer. The correction table was used to account for the losses of the cables and attenuators used as part of the system to connect the EUT to the analyzer at all frequencies of interest.

7.2. Conducted Emission

7.2.1. Test Limit

FCC Part 15 Subpart C Paragraph 15.207 Limits		
Frequency (MHz)	QP (dBuV)	AV (dBuV)
0.15 - 0.50	66 - 56	56 - 46
0.50 - 5.0	56	46
5.0 - 30	60	50

Note 1: The lower limit shall apply at the transition frequencies.

Note 2: The limit decreases linearly with the logarithm of the frequency in the range 0.15 MHz to 0.5 MHz.

7.2.2. Test Setup

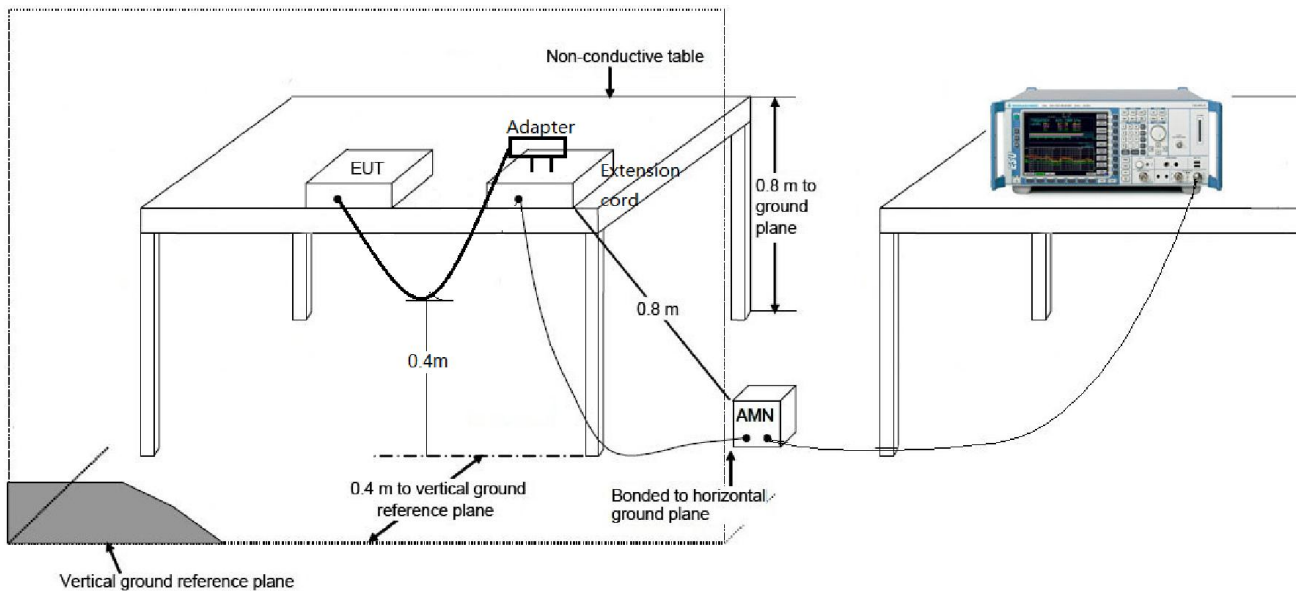

7.2.3. Test Result

The EUT is powered by battery, so this requirement does not apply.

7.3. Radiated Emission

7.3.1. Test Limit

FCC Part 15 Subpart C Paragraph 15.209		
Frequency (MHz)	Field Strength (microvolts/meter)	Measurement Distance (uV/m)
0.009-0.490	2400/F(kHz)	300
0.490-1.705	24000/F(kHz)	30
1.705-30.0	30	30
30-80	100**	3
80-216	150**	3
216-960	200**	3
Above 960	500	3

Note 1: The lower limit shall apply at the transition frequency.

Note 2: Distance refers to the distance in meters between the measuring instrument antenna and the closed point of any part of the device or system.

Note 3: E field strength (dBuV/m) = 20 log E field strength (uV/m).

FCC Part 15 Subpart C Paragraph 15.249		
Fundamental Frequency	Field Strength of Fundamental (millivolts/meter)	Field Strength of Harmonics (microvolts/meter)
902-928(MHz)	50	500
2400-2483.5(MHz)	50	500
5725-5875(MHz)	50	500
24.0-24.25(GHz)	250	2500

FCC Part 15.249 (d), Emissions radiated outside of the specified frequency bands, except for harmonics, shall be attenuated by at least 50 dB below the level of the fundamental or to the general radiated emission limits in §15.209, whichever is the lesser attenuation.

7.3.2. Test Setup

9kHz ~ 30MHz Test Setup:

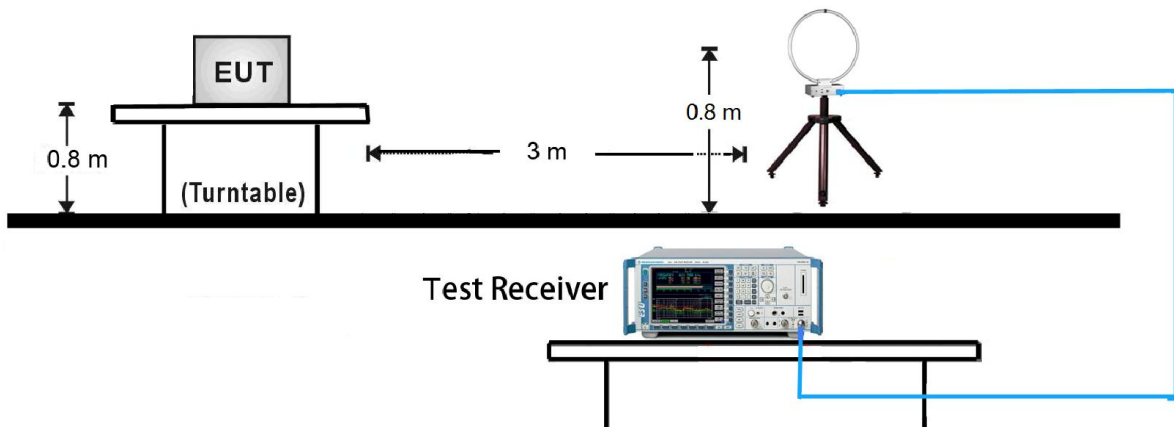

30MHz ~ 1GHz Test Setup:

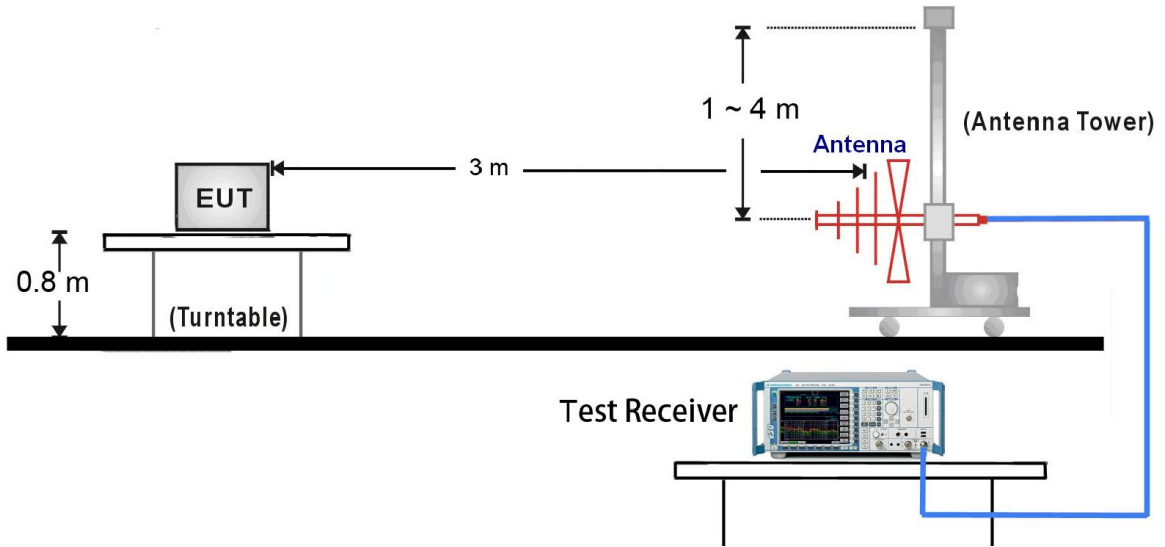

1GHz ~ 25GHz Test Setup:

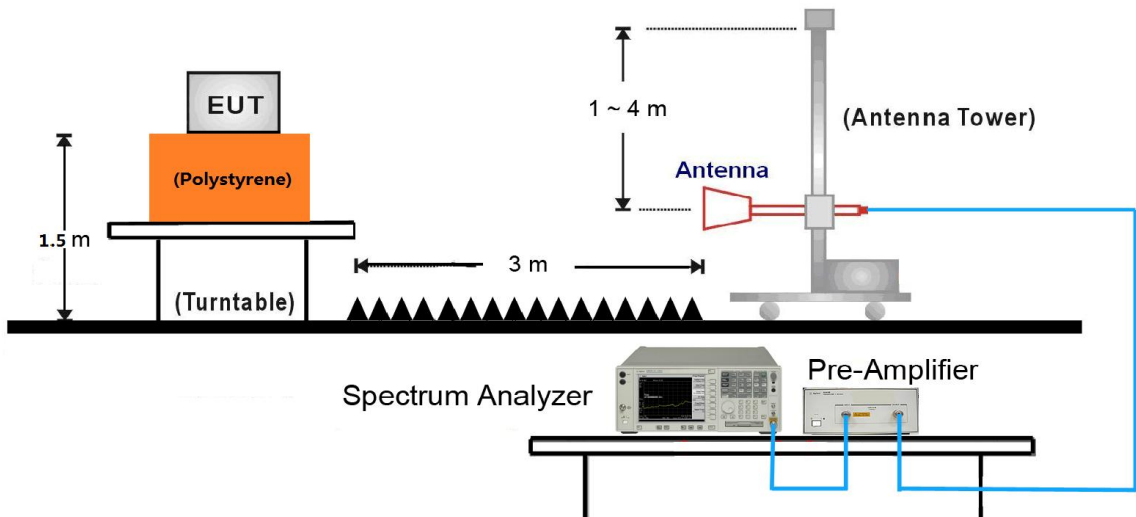

7.3.3. Test Result

Total Time (Ton) (ms)	Duty Cycle (%)	Duty Cycle Factor (dB)
4.8	4.8	-26.4

Note: Duty Cycle Factor = $20 * \log(\text{Duty Cycle})$

Total Time (Ton) (ms) = $0.4 * 12 \text{ (ms)} = 4.8 \text{ (ms)}$

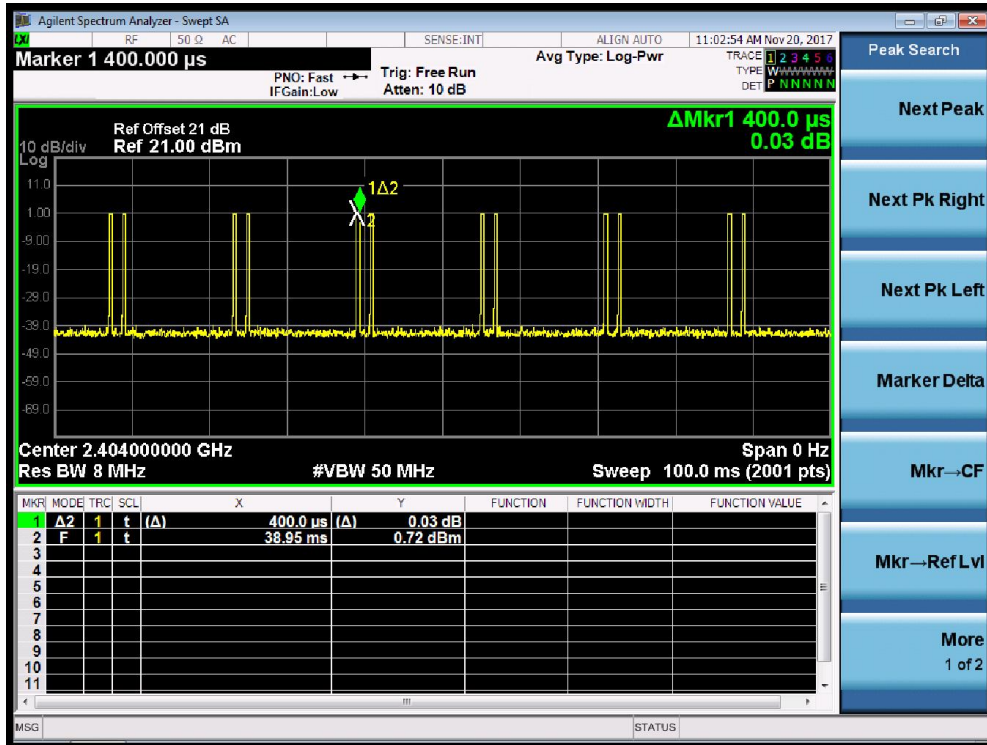

Test Mode:	Transmission	Test Site:	AC1
Remark:	Fundamental Radiated Emission	Test Engineer:	Bruce Wang

Frequency (MHz)	Reading Level (dB μ V)	Factor (dB)	Duty Cycle Factor (dB)	Measure Level (dB μ V/m)	Limit (dB μ V/m)	Margin (dB)	Detector	Polarization
2404	63.0	31.2	N/A	94.2	114.0	-19.8	PK	Horizontal
	63.0	31.2	-26.4	67.8	94.0	-26.2	AV	Horizontal
	49.3	31.2	N/A	80.5	114.0	-33.5	PK	Vertical
	49.3	31.2	-26.4	54.1	94.0	-39.9	AV	Vertical
2420	61.7	31.2	N/A	92.9	114.0	-21.1	PK	Horizontal
	61.7	31.2	-26.4	66.5	94.0	-27.5	AV	Horizontal
	51.3	31.2	N/A	82.5	114.0	-31.5	PK	Vertical
	51.3	31.2	-26.4	56.1	94.0	-37.9	AV	Vertical
2479	60.6	31.2	N/A	91.8	114.0	-22.2	PK	Horizontal
	60.6	31.2	-26.4	65.4	94.0	-28.6	AV	Horizontal
	50.4	31.2	N/A	81.6	114.0	-32.4	PK	Vertical
	50.4	31.2	-26.4	55.2	94.0	-38.8	AV	Vertical

Note 1: Peak Measure Level (dB μ V/m) = Reading Level (dB μ V) + Factor (dB)

Average Measure Level = Peak Measure Level + Duty Cycle Factor

Factor (dB) = Cable Loss (dB) + Antenna Factor (dB/m)

Note 2: All readings below 1GHz are peak, above 1GHz are performed with peak and/or average measurements as necessary.

Test Mode:	Transmission	Test Site:	AC1
Remark:	Harmonic Radiated Emission	Test Engineer:	Bruce Wang

Frequency (MHz)	Reading Level (dB μ V)	Factor (dB)	Duty Cycle Factor (dB)	Measure Level (dB μ V/m)	Limit (dB μ V/m)	Margin (dB)	Detector	Polarization
2404MHz								
4808.0	55.3	2.7	N/A	58.0	74.0	-16.0	PK	Horizontal
4808.0	55.3	2.7	-26.4	31.6	54.0	-22.4	AV	Horizontal
4808.0	45.6	2.7	N/A	48.3	74.0	-25.7	PK	Vertical
4808.0	45.6	2.7	-26.4	21.9	54.0	-32.1	AV	Vertical
7212.0	35.8	7.8	N/A	43.6	74.0	-30.4	PK	Horizontal
7212.0	34.3	7.8	N/A	42.1	74.0	-31.9	PK	Vertical
2420MHz								
4842.0	56.3	2.7	N/A	59.0	74.0	-15.0	PK	Horizontal
4842.0	56.3	2.7	-26.4	32.6	54.0	-21.4	AV	Horizontal
4842.0	44.1	2.7	N/A	46.8	74.0	-27.2	PK	Vertical
4842.0	44.1	2.7	-26.4	20.4	54.0	-33.6	AV	Vertical
7260.0	34.9	7.9	N/A	42.8	74.0	-31.2	PK	Horizontal
7260.0	34.5	7.9	N/A	42.4	74.0	-31.6	PK	Vertical
2479MHz								
4961.0	56.3	2.9	N/A	59.2	74.0	-14.8	PK	Horizontal
4961.0	56.3	2.9	-26.4	32.8	54.0	-21.2	AV	Horizontal
4961.0	45.8	2.9	N/A	48.7	74.0	-25.3	PK	Vertical
4961.0	45.8	2.9	-26.4	22.3	54.0	-31.7	AV	Vertical
7437.0	34.2	8.0	N/A	42.2	74.0	-31.8	PK	Horizontal
7437.0	33.8	8.0	N/A	41.8	74.0	-32.2	PK	Vertical

Note 1: Measure Level (dB μ V/m) = Reading Level (dB μ V) + Factor (dB)

Average Measure Level = Peak Measure Level + Duty Cycle Factor

Factor (dB) = Cable Loss (dB) + Antenna Factor (dB/m) – Pre Amplifier Gain (dB)

Note 2: Average measurement was not performed when the peak level lower than average limit.

Test Mode:	Transmission	Test Site:	AC1
Frequency	2404MHz	Test Engineer:	Bruce Wang
Remark:	General Radiated Emission		

Frequency (MHz)	Reading Level (dBμV)	Factor (dB)	Measure Level (dBμV/m)	Limit (dBμV/m)	Margin (dB)	Detector	Polarization
37.8	1.8	14.2	16.0	44.2 (Note 4)	-28.2	QP	Horizontal
848.2	1.6	23.6	25.2	46.0	-20.8	QP	Horizontal
41.2	1.3	14.5	15.8	44.2 (Note 4)	-28.4	QP	Vertical
820.6	1.4	23.4	24.8	46.0	-21.2	QP	Vertical
8667.0	36.0	8.9	44.9	74.0	-29.1	PK	Horizontal
11302.0	35.8	12.5	48.3	74.0	-25.7	PK	Horizontal
7800.0	36.5	8.4	44.9	74.0	-29.1	PK	Vertical
10851.5	35.1	12.8	47.9	74.0	-26.1	PK	Vertical

Note 1: Measure Level (dBμV/m) = Reading Level (dBμV) + Factor (dB)

Factor (dB) = Cable Loss (dB) + Antenna Factor (dB/m) – Pre Amplifier Gain (dB)

Note 2: Average measurement was not performed when the peak level lower than average limit.

Note 3: The test trace is same as the ambient noise (the test frequency range: 9 kHz ~ 30 MHz and 18 GHz ~ 25 GHz), therefore no data appear in the report.

Note 4: Emissions radiated outside of the specified frequency bands, except for harmonics, shall be attenuated by at least 50 dB below the level of the fundamental or to the general radiated emission limits in §15.209, whichever is the lesser attenuation.

Test Mode:	Transmission	Test Site:	AC1
Frequency	2420MHz	Test Engineer:	Bruce Wang
Remark:	General Radiated Emission		

Frequency (MHz)	Reading Level (dBμV)	Factor (dB)	Measure Level (dBμV/m)	Limit (dBμV/m)	Margin (dB)	Detector	Polarization
134.3	1.1	14.1	15.2	43.5	-28.3	QP	Horizontal
910.8	1.0	24.5	25.5	46.0	-20.5	QP	Horizontal
133.8	3.0	14.0	17.0	43.5	-26.5	QP	Vertical
918.0	1.4	24.6	26.0	46.0	-20.0	QP	Vertical
8599.0	36.1	8.7	44.8	74.0	-29.2	PK	Horizontal
10868.5	35.6	12.8	48.4	74.0	-25.6	PK	Horizontal
9177.0	35.4	10.0	45.4	74.0	-28.6	PK	Vertical
14234.5	34.9	15.5	50.4	74.0	-23.6	PK	Vertical

Note 1: Measure Level (dBμV/m) = Reading Level (dBμV) + Factor (dB)

Factor (dB) = Cable Loss (dB) + Antenna Factor (dB/m) – Pre Amplifier Gain (dB)

Note 2: Average measurement was not performed when the peak level lower than average limit.

Note 3: The test trace is same as the ambient noise (the test frequency range: 9 kHz ~ 30 MHz and 18 GHz ~ 25 GHz), therefore no data appear in the report.

Note 4: Emissions radiated outside of the specified frequency bands, except for harmonics, shall be attenuated by at least 50 dB below the level of the fundamental or to the general radiated emission limits in §15.209, whichever is the lesser attenuation.

Test Mode:	Transmission	Test Site:	AC1
Frequency	2479MHz	Test Engineer:	Bruce Wang
Remark:	General Radiated Emission		

Frequency (MHz)	Reading Level (dBμV)	Factor (dB)	Measure Level (dBμV/m)	Limit (dBμV/m)	Margin (dB)	Detector	Polarization
55.2	1.5	14.6	16.1	40.5 (Note 4)	-24.4	QP	Horizontal
790.0	0.9	22.7	23.6	46.0	-22.4	QP	Horizontal
57.6	6.6	14.2	20.8	40.5 (Note 4)	-19.7	QP	Vertical
734.2	0.8	22.1	22.9	46.0	-23.1	QP	Vertical
7604.5	33.5	10.8	44.3	74.0	-29.7	PK	Horizontal
11608.0	31.4	17.4	48.8	74.0	-25.2	PK	Horizontal
7451.5	33.2	10.9	44.1	74.0	-29.9	PK	Vertical
12067.0	31.8	17.0	48.8	74.0	-25.2	PK	Vertical

Note 1: Measure Level (dBμV/m) = Reading Level (dBμV) + Factor (dB)

Factor (dB) = Cable Loss (dB) + Antenna Factor (dB/m) – Pre Amplifier Gain (dB)

Note 2: Average measurement was not performed when the peak level lower than average limit.

Note 3: The test trace is same as the ambient noise (the test frequency range: 9 kHz ~ 30 MHz and 18 GHz ~ 25 GHz), therefore no data appear in the report.

Note 4: Emissions radiated outside of the specified frequency bands, except for harmonics, shall be attenuated by at least 50 dB below the level of the fundamental or to the general radiated emission limits in §15.209, whichever is the lesser attenuation.

7.4. Radiated Restricted Band Edge Measurement

7.4.1. Test Result

Site: AC1	Time: 2017/11/18 - 13:13
Limit: FCC_Part15.209_RE(3m)	Engineer: Bruce Wang
Probe: BBHA9120D_1-18GHz	Polarity: Horizontal
EUT: JCHR35H2	Power: By Battery
Test Mode: Transmit at low channel 2404MHz	

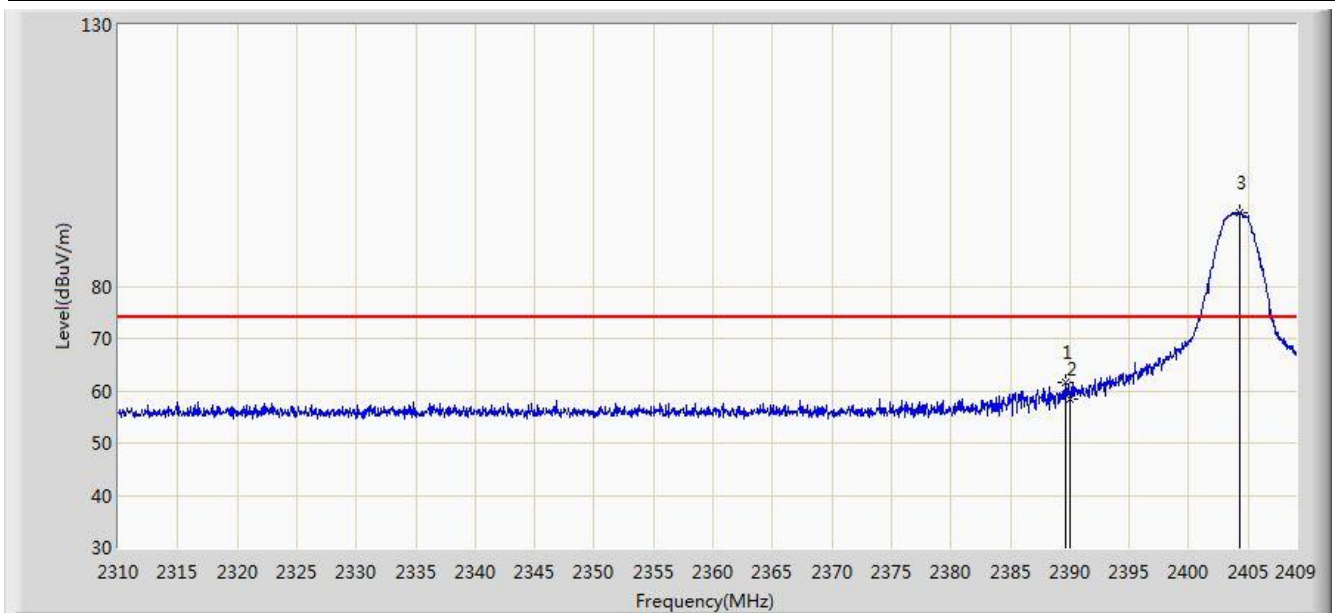

No	Flag	Mark	Frequency (MHz)	Measure Level (dBuV/m)	Reading Level (dBuV)	Over Limit (dB)	Limit (dBuV/m)	Factor (dB)	Duty Cycle Factor (dB)	Type
1			2389.695	61.538	30.335	-12.462	74.000	31.204	N/A	PK
			2389.695	35.138	30.335	-18.862	54.000	31.204	-26.400	AV
2			2390.000	58.524	27.321	-15.476	74.000	31.203	N/A	PK
			2390.000	32.124	27.321	-21.876	54.000	31.203	-26.400	AV
3		*	2404.347	94.141	62.960	N/A	N/A	31.181	N/A	PK

Note: Peak Measure Level (dB μ V/m) = Reading Level (dB μ V) + Factor (dB)

Average Measure Level = Peak Measure Level + Duty Cycle Factor

Factor (dB) = Cable Loss (dB) + Antenna Factor (dB/m)

Site: AC1	Time: 2017/11/18 - 13:20
Limit: FCC_Part15.209_RE(3m)	Engineer: Bruce Wang
Probe: BBHA9120D_1-18GHz	Polarity: Vertical
EUT: JCHR35H2	Power: By Battery
Test Mode: Transmit at low channel 2404MHz	

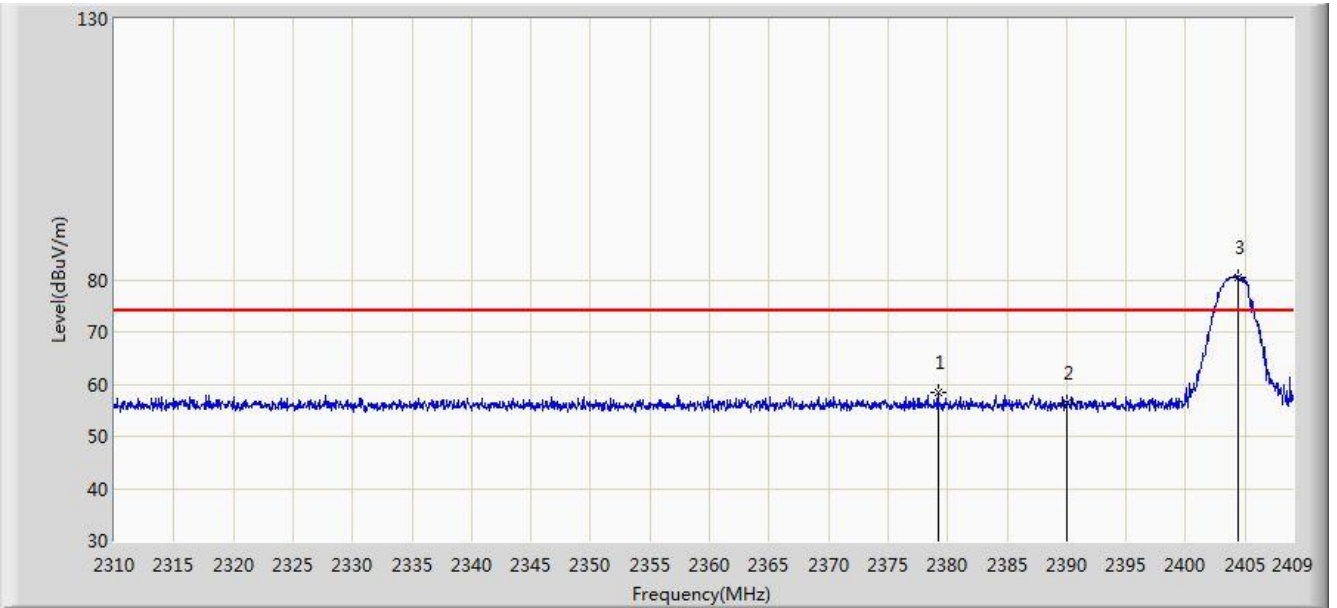

No	Flag	Mark	Frequency (MHz)	Measure Level (dBuV/m)	Reading Level (dBuV)	Over Limit (dB)	Limit (dBuV/m)	Factor (dB)	Duty Cycle Factor (dB)	Type
1			2379.201	58.436	27.213	-15.564	74.000	31.223	N/A	PK
			2379.201	32.036	27.213	-21.964	54.000	31.223	-26.400	AV
2			2390.000	56.458	25.255	-17.542	74.000	31.203	N/A	PK
			2390.000	30.058	25.255	-23.942	54.000	31.203	-26.400	AV
3		*	2404.446	80.460	49.279	N/A	N/A	31.181	N/A	PK

Note: Peak Measure Level (dBuV/m) = Reading Level (dBuV) + Factor (dB)

Average Measure Level = Peak Measure Level + Duty Cycle Factor

Factor (dB) = Cable Loss (dB) + Antenna Factor (dB/m)

Site: AC1	Time: 2017/11/18 - 13:24
Limit: FCC_Part15.209_RE(3m)	Engineer: Bruce Wang
Probe: BBHA9120D_1-18GHz	Polarity: Horizontal
EUT: JCHR35H2	Power: By Battery
Test Mode: Transmit at high channel 2479MHz	

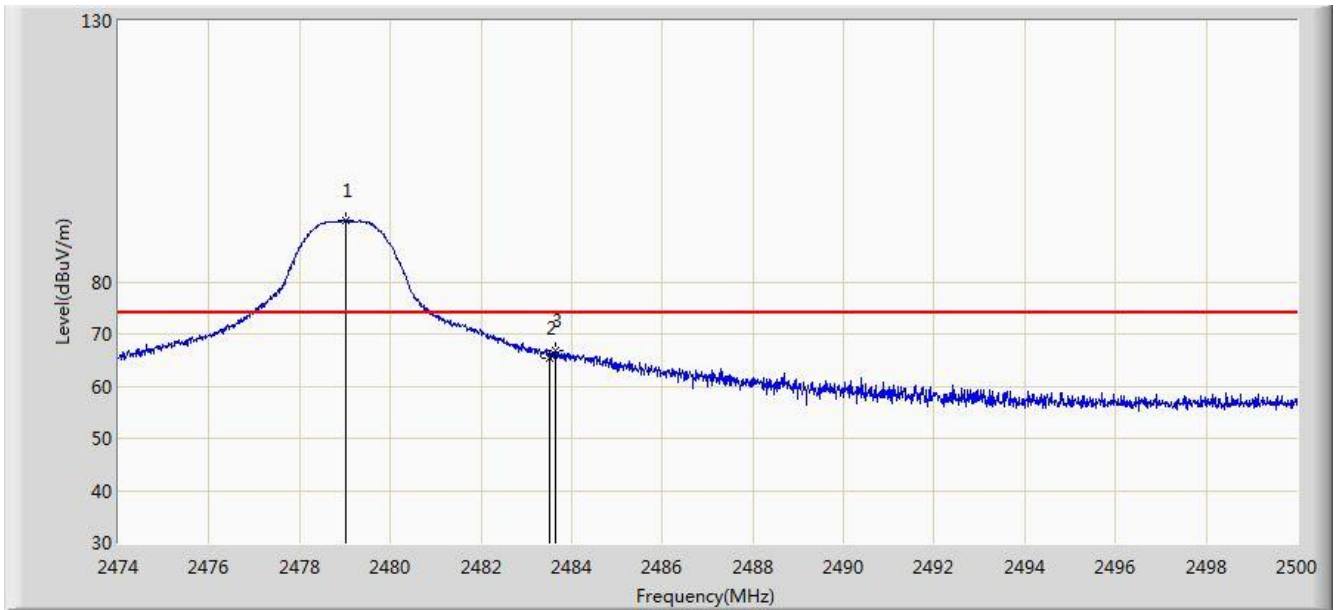

No	Flag	Mark	Frequency (MHz)	Measure Level (dBuV/m)	Reading Level (dBuV)	Over Limit (dB)	Limit (dBuV/m)	Factor (dB)	Duty Cycle Factor (dB)	Type
1		*	2479.018	91.817	60.635	N/A	N/A	31.182	N/A	PK
2			2483.500	65.507	34.314	-8.493	74.000	31.194	N/A	PK
			2483.500	39.107	34.314	-14.893	54.000	31.194	-26.400	AV
3			2483.646	66.681	35.487	-7.319	74.000	31.194	N/A	PK
			2483.646	40.281	35.487	-13.719	54.000	31.194	-26.400	AV

Note: Peak Measure Level (dB μ V/m) = Reading Level (dB μ V) + Factor (dB)

Average Measure Level = Peak Measure Level + Duty Cycle Factor

Factor (dB) = Cable Loss (dB) + Antenna Factor (dB/m)

Site: AC1	Time: 2017/11/18 - 13:29
Limit: FCC_Part15.209_RE(3m)	Engineer: Bruce Wang
Probe: BBHA9120D_1-18GHz	Polarity: Vertical
EUT: JCHR35H2	Power: By Battery
Test Mode: Transmit at high channel 2479MHz	

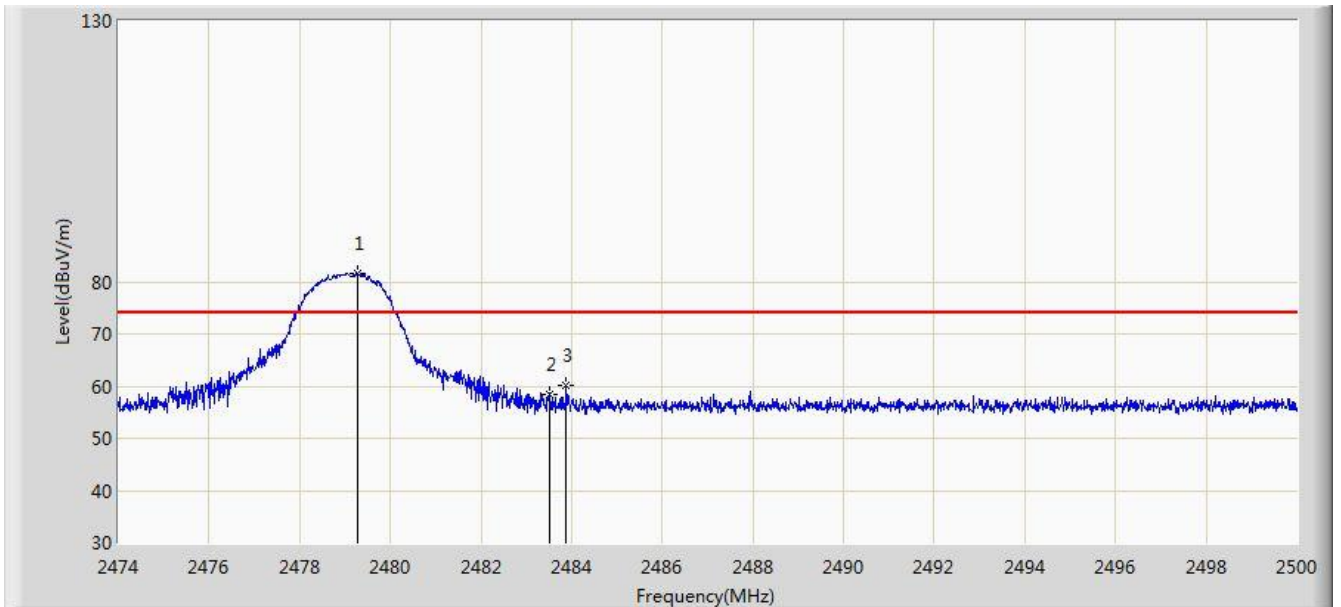

No	Flag	Mark	Frequency (MHz)	Measure Level (dBuV/m)	Reading Level (dBuV)	Over Limit (dB)	Limit (dBuV/m)	Factor (dB)	Duty Cycle Factor (dB)	Type
1		*	2479.278	81.556	50.374	N/A	N/A	31.182	N/A	PK
2			2483.500	58.416	27.223	-15.584	74.000	31.194	N/A	PK
			2483.500	32.016	27.223	-21.984	54.000	31.194	-26.400	AV
3			2483.880	60.246	29.052	-13.754	74.000	31.194	N/A	PK
			2483.880	33.846	29.052	-20.154	54.000	31.194	-26.400	AV

Note: Peak Measure Level (dB μ V/m) = Reading Level (dB μ V) + Factor (dB)

Average Measure Level = Peak Measure Level + Duty Cycle Factor

Factor (dB) = Cable Loss (dB) + Antenna Factor (dB/m)

7.5. Output Power Measurement

7.5.1. Test Limit

The maximum out power shall be less 1 Watt (30dBm).

7.5.2. Test Procedure Used

KDB 558074 D01v04 - Section 9.1.2 PKPM1 - Peak Power Method

7.5.3. Test Setting

Method PKPM1 (Peak Power Measurement of Signals with DTS BW \leq 50MHz)

Peak power measurements were performed only when the EUT was transmitting at its maximum power control level using a broadband power meter with a pulse sensor. The pulse sensor employs a VBW = 50MHz so this method was only used for signals whose DTS bandwidth was less than or equal to 50MHz.

7.5.4. Test Setup

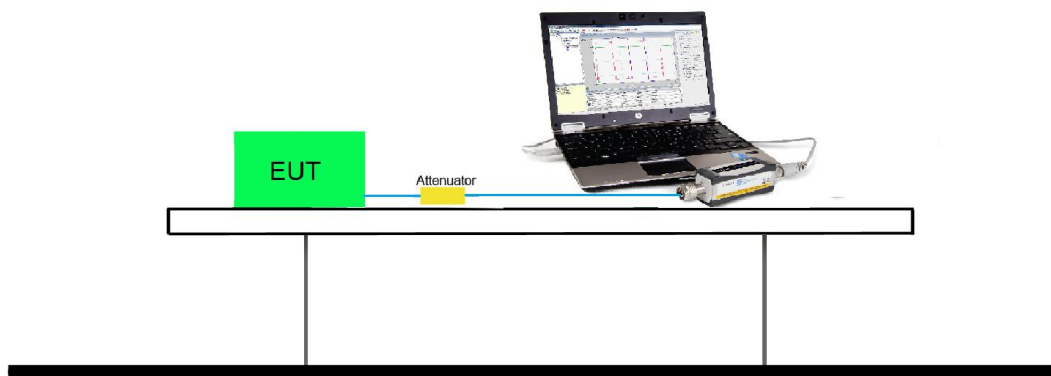

7.5.5. Test Result of Output Power

Test Result of Peak Output Power

No.	Frequency (MHz)	Peak Power (dBm)	Limit (dBm)	Result
01	2404	2.21	≤ 30	Pass
02	2420	2.15	≤ 30	Pass
03	2479	1.51	≤ 30	Pass

Test Result of Average Output Power (Reporting Only)

No.	Frequency (MHz)	Average Power (dBm)	Limit (dBm)	Result
01	2404	0.90	≤ 30	Pass
02	2420	0.86	≤ 30	Pass
03	2479	0.04	≤ 30	Pass

7.6. 20dB Spectrum Bandwidth Measurement

7.6.1. Test Limit

Intentional radiators must be designed to ensure that the 20 dB bandwidth of the emission in the specific band (2404 ~ 2479).

7.6.2. Test Procedure used

ANSI C63.10 Clause 6.9.2

7.6.3. Test Setting

1. Set the spectrum span range to overlap the nominal center frequency
2. Set RBW = 100 kHz
3. VBW $\geq 3 \times$ RBW
4. Detector = Peak
5. Trace mode = max hold
6. Sweep = auto couple
7. Allow the trace was allowed to stabilize and marker the highest level.
8. Determine the display level (the highest level - 20dB) and place two markers, one at the lowest frequency and the other at the highest frequency.

7.6.4. Test Setup

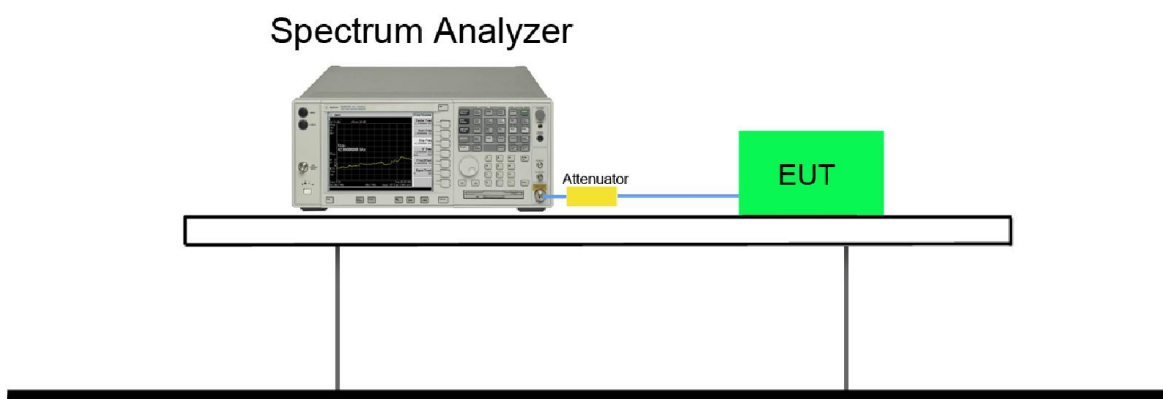

7.6.5. Test Result

Frequency (MHz)	Frequency Range (MHz)	Frequency Range (MHz)	Result
2404	2404.056	---	Pass
2479	---	2479.060	Pass

20dB Spectrum Bandwidth

2404 MHz



2479 MHz



7.7. 99% Bandwidth Measurement

7.7.1. Test Limit

N/A

7.7.2. Test Procedure used

ANSI C63.10 Section 6.9

7.7.3. Test Setting

1. The analyzers' automatic bandwidth measurement capability was used to perform the 99% bandwidth measurement. The bandwidth measurement was not influenced by any intermediated power nulls in the fundamental emission.
2. RBW = approximately 1% to 5% of the OBW.
3. VBW $\geq 3 \times$ RBW.
4. Detector = Peak.
5. Trace mode = max hold.

7.7.4. Test Setup

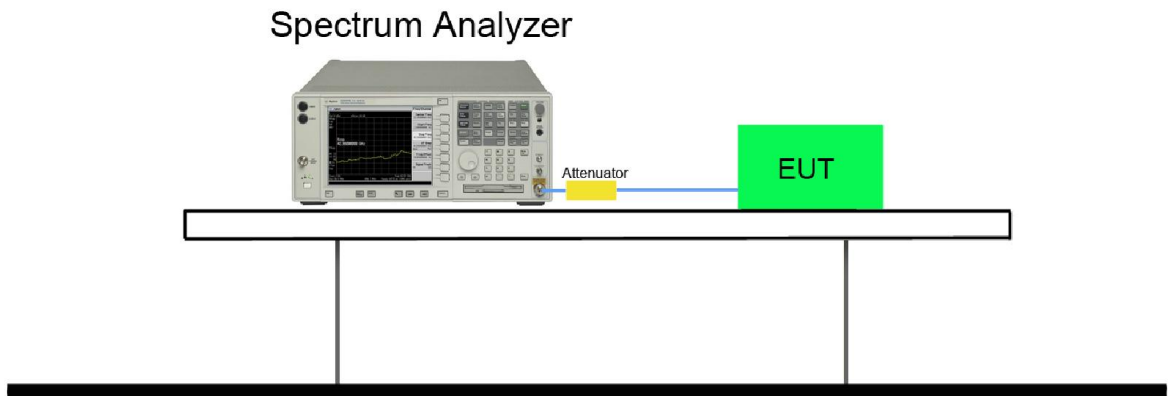

7.7.5. Test Result

Frequency (MHz)	99% Bandwidth (MHz)
2404	2.94
2420	2.67
2479	2.23

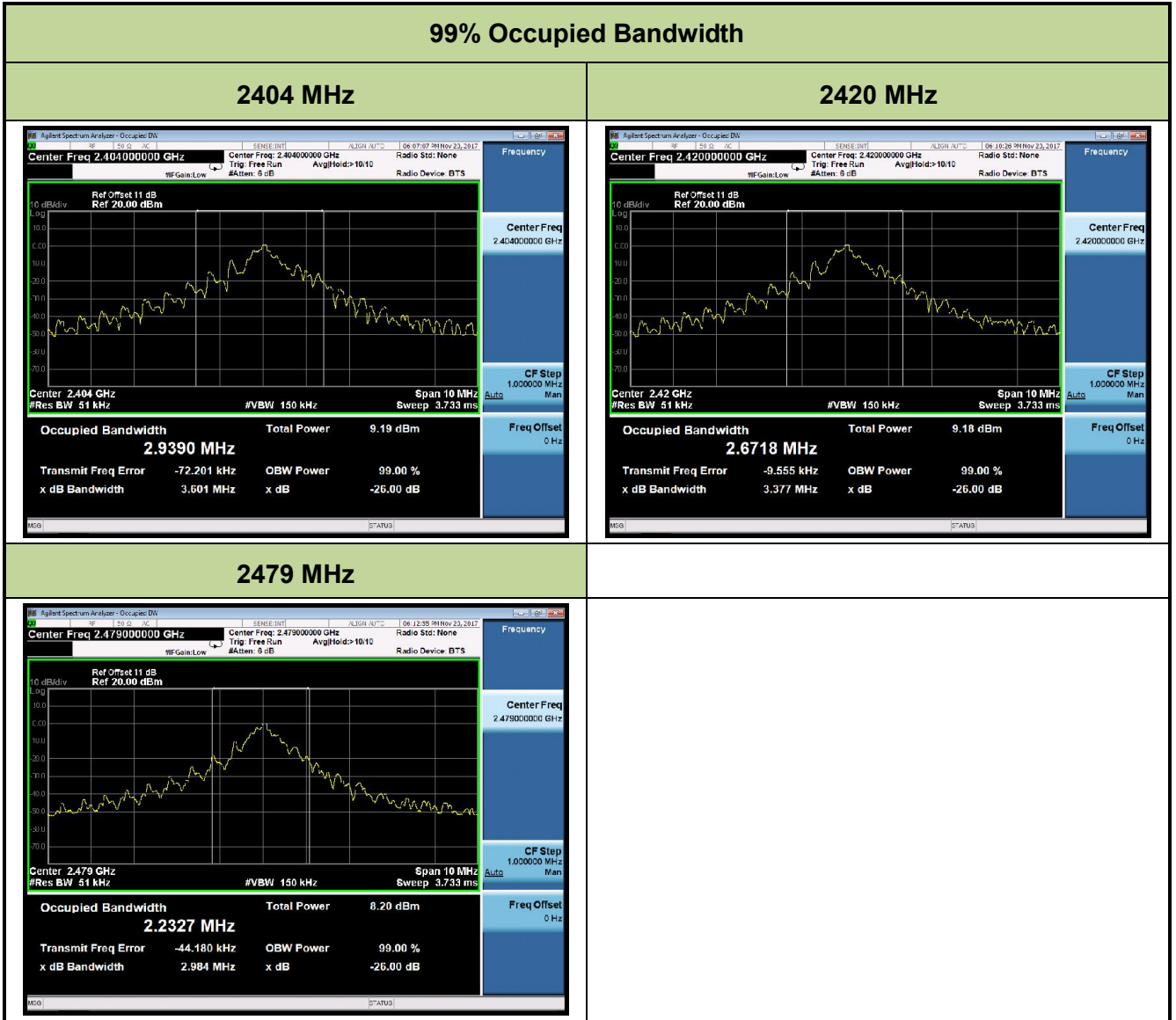

8. CONCLUSION

The data collected relate only the item(s) tested and show that the **Remote Control** is in compliance with Part 15C of the FCC Rules.