

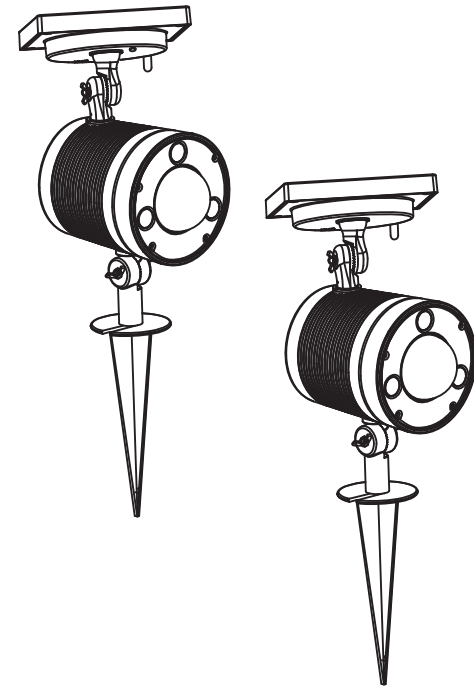

SOLAR PROJECTION SPOTLIGHT SET
BLUETOOTH® CONTROLLED



Instruction Manual

Model: Q01BM1740-08

INSTALLATION

1. Prior to installation download the app to ensure phone compatibility. Download the Westinghouse Smart Landscape App for free from the App Store or Google Play. You may also scan the QR codes below. This App is compatible with iPhone (4 generation or above) and Android™ devices (5.0 or above).



2. Ensure that Bluetooth is enabled on your cellular device and make it discoverable. The way you do this depends on the device. If you need help visit the manufacturer's website to learn how.

3. Spotlights include a "Parent" and "Child" light. The light with the large sticker on top is the "Parent". This light also has a reset button located under the solar panel. Only the "parent" light will operate independently. With the solar panels facing down, place each light on a flat surface. This will simulate darkness. The "Parent" light power switch must be turned on first. Next, turn on the "Child" light power switch. It may take 15 to 30 seconds for both lights to illuminate equally.

4. Remove protective film from solar panels and product stickers.

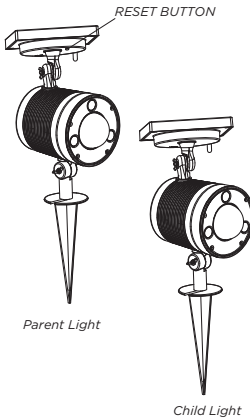
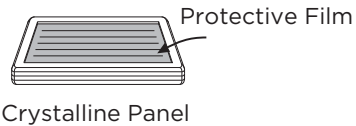

ASSEMBLY (SOME PARTS MAY COME PRE-ASSEMBLED)

5. Attach (Part A) to (Part C) by aligning the holes, then insert (Parts B & D) and tighten (Part B) until secure. To adjust the light head, loosen (Part B) and position the light head. When desired position is achieved, tighten (Part B) until secure. To adjust the solar panel loosen the wing nut and position the panel. When desired position is achieved, tighten wing nut until secure. Carefully insert (Part C) into the ground where desired. Push the stake into the ground until the top collar is even with the ground surface.

NOTE: If the ground is hard and packed, moisten the ground with water before inserting the stake to avoid breakage.

6. Install solar light where it will receive direct sunlight for at least 8 hours each day. Avoid shadowed locations and install away from nighttime light sources which will prohibit the light from working properly.

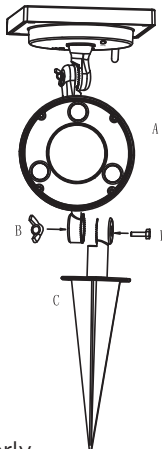

7. **FOR FIRST TIME USE:** Solar light needs to charge in full sunlight for 8-12 hours with the switch in the “ON” position to allow the rechargeable batteries to reach maximum capacity.

OPERATION

The operational range between your Bluetooth device and the lights is 32ft-82ft(10m-25m). The distance depends on the Bluetooth device and environment. Open the App and select *View Tutorial* for instructions or select *Control My Lights* to begin using your lights. The timer function is not available for this spotlight set. To extend runtime, the Bluetooth control is inactive after 4 hours of use. It will resume Bluetooth control the next day once battery is recharged. To over-ride this measure you can turn off and on your lights and follow the instructions in step 3. This will reduce the runtime until the sun recharges the batteries in your lights.



32ft-82ft (10m-25m)

APP TUTORIAL



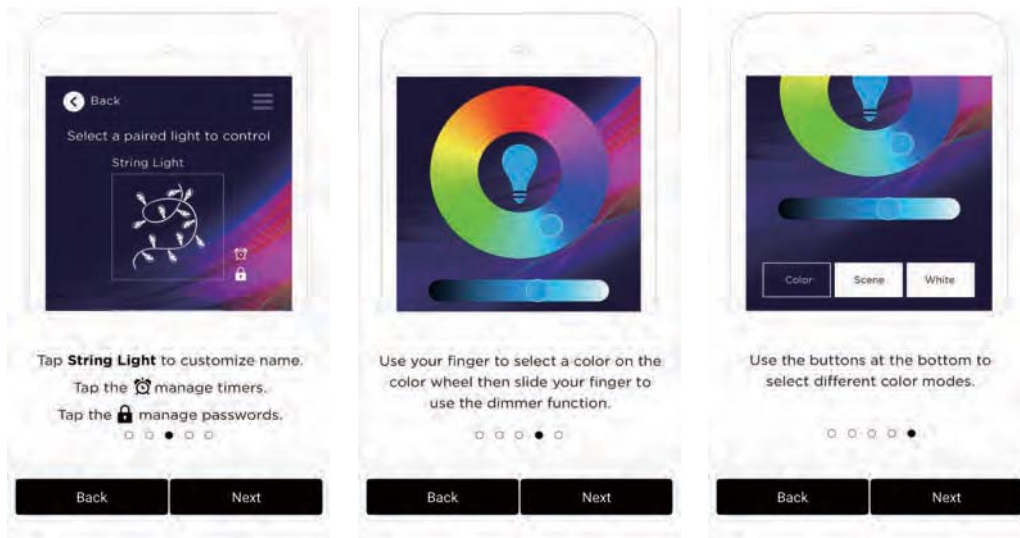

RESET BUTTON INSTRUCTIONS

If you are unable to reset your user name and password using the App on your cell phone, set the "parent" light switch to "ON" position and press the reset button on the "parent" light for at least 3 seconds until the light color turns red. The app will prompt you to assign a new password. Enter "1234". Tap the lock icon on the app screen. Select desired password option and reset the password using your own number sequence. Note that any previously saved functions will need to be reset.

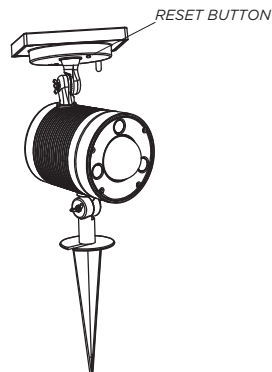

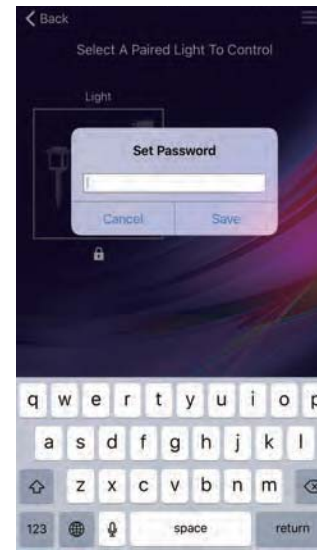

TROUBLE SHOOTING

If the light doesn't turn on, remove battery, wipe both ends with a clean, dry cloth and reinstall battery. Check the battery to ensure that it is making secure contact with the terminals. If this doesn't work, replace with a new battery.

APP HELP

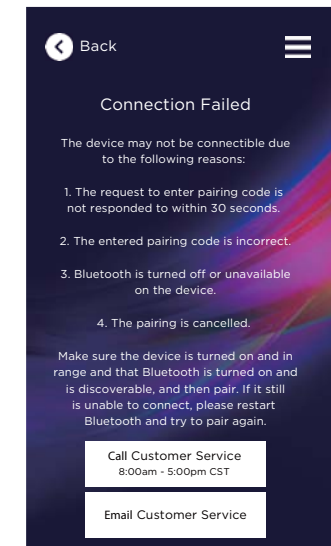
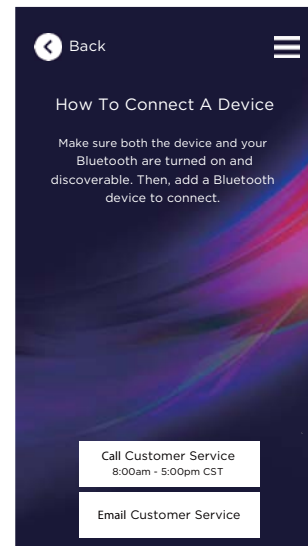

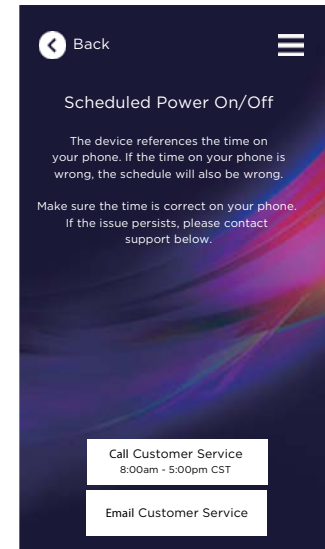
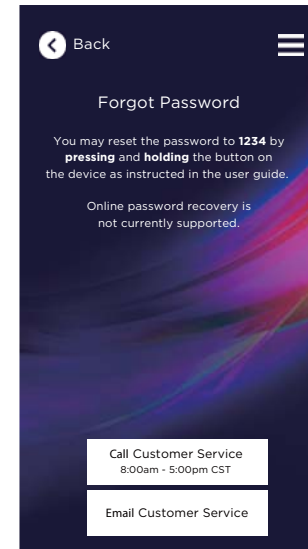
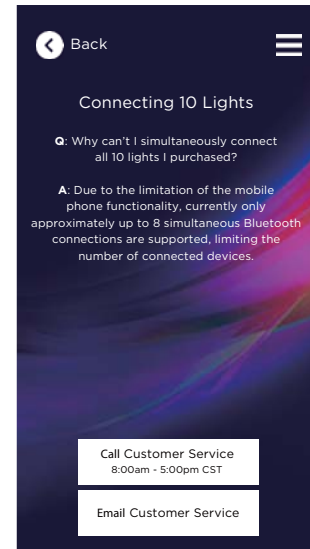

REPLACING THE BATTERY

Slide the power switch to the "OFF" position. Remove the four screws from the top section using a Phillips head screwdriver. Remove the old battery and replace with a new 3.7V, 2000 mAh lithium (18650) rechargeable battery. Replace the top section with the four screws. Slide the power switch to the "ON" position. **For optimum performance, allow solar light to charge in direct sunlight.**

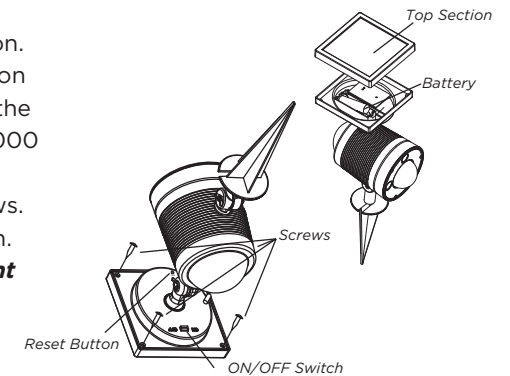

WARNING: Do not dispose of lithium batteries in municipal waste stream or by fire as batteries may explode. Do not open, short circuit, or mutilate batteries. Dispose of batteries in accordance with Local, State, and Federal regulations. Contains no toxic metals. Do not mix old and new batteries. Do not mix alkaline, standard (Carbon-Zinc), or rechargeable (Nickel Cadmium or Nickel Metal Hydride) batteries .

, WESTINGHOUSE, are trademarks of Westinghouse Electric Corporation. Used under license by Sky Rich Star Limited. All Rights Reserved.

iPhone is a registered trademark of Apple Inc. registered in the U.S. and other countries. Android is a trademark of Google Inc. Google Play and the Google Play logo are trademarks of Google Inc.

The Bluetooth® word mark and logos are registered trademarks owned by Bluetooth SIG, Inc. and use of such marks by Sky Rich Star Limited is under license. Other trademarks and trade names are those of their respective owners.

The Westinghouse Smart Landscape App may require periodic updates without prior notice. Check your mobile app store for the most updated version.

For assistance with assembly or instruction, parts and customer service, call:

U.S.A. & Canada only: 1-844-551-0680

8am – 5pm Monday – Friday, Central Standard Time Or email: Customerservice@qx-usa.com

www.westinghousesolarlights.com

FCC Warning

This device complies with part 15 of the FCC Rules. Operation is subject to the following two conditions:

(1) This device may not cause harmful interference, and (2) this device must accept any interference received, including interference that may cause undesired operation.

Any Changes or modifications not expressly approved by the party responsible for compliance could void the user's authority to operate the equipment.

Note: This equipment has been tested and found to comply with the limits for a Class B digital device, pursuant to part 15 of the FCC Rules. These limits are designed to provide reasonable protection against harmful interference in a residential installation. This equipment generates uses and can radiate radio frequency energy and, if not installed and used in accordance with the instructions, may cause harmful interference to radio communications. However, there is no guarantee that interference will not occur in a particular installation. If this equipment does cause harmful interference to radio or television reception, which can be determined by turning the equipment off and on, the user is encouraged to try to correct the interference by one or more of the following measures:

- ▶ -Reorient or relocate the receiving antenna.
- ▶ -Increase the separation between the equipment and receiver.
- ▶ -Connect the equipment into an outlet on a circuit different from that to which the receiver is connected.
- ▶ -Consult the dealer or an experienced radio/TV technician for help.

This equipment complies with FCC radiation exposure limits set forth for an uncontrolled environment. This equipment should be installed and operated with minimum distance 20cm between the radiator & your body.